

INTERACTIVE SCHEMATIC

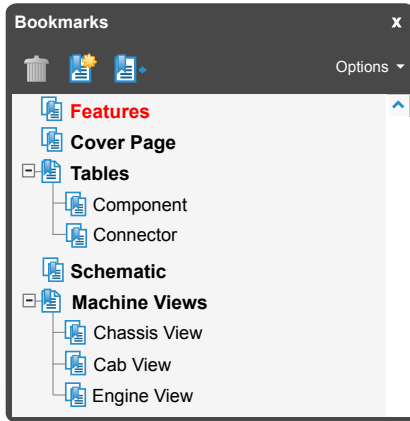

The Bookmarks panel will allow you to quickly navigate to points of interest.

****This document is best viewed at a screen resolution of 1024 X 768.***

To set your screen resolution do the following:
RIGHT CLICK on the **DESKTOP**.
 Select **PROPERTIES**.
CLICK the **SETTINGS TAB**.
MOVE THE SLIDER under **SCREEN RESOLUTION** until it shows **1024 X 768**.
CLICK OK to apply the resolution.

**Due to different monitor sizes and PDF reader preferences there may be some variance in linked schematic locations*

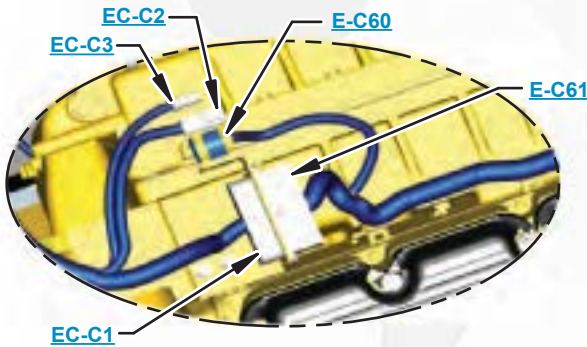

Click on any text that is **BLUE** and underlined. These are hyperlinks that can be used to navigate the schematic and machine views.



[Click here to save a copy of this interactive schematic to your desktop](#)

VIEW ALL CALLOUTS

When only one callout is showing on a machine view, clicking on this button will make all of the callouts visible. This button is located in the top right corner of every machine view page.

HOTKEYS (Keyboard Shortcuts)		
	FUNCTION	KEYS
	Zoom In	“CTRL” / “+”
	Zoom Out	“CTRL” / “-”
	Fit to Page	“CTRL” / “0” (zero)
	Hand Tool	“SPACEBAR” (hold down)
	Find	“CTRL” / “F”
	Search	“CTRL” / “SHIFT” / “F”

ELECTRICAL SYMBOLS				
Pressure Switch	Temperature Switch	Level Switch	Flow Switch	Circuit Breaker

BASIC HYDRAULIC COMPONENT SYMBOLS	
Pump or Motor	Variability
Fluid Conditioner	Spring (Adjustable)

[Click here to view the Schematic Symbols and Definitions page](#)



SCHEMATIC SYMBOLS AND DEFINITIONS

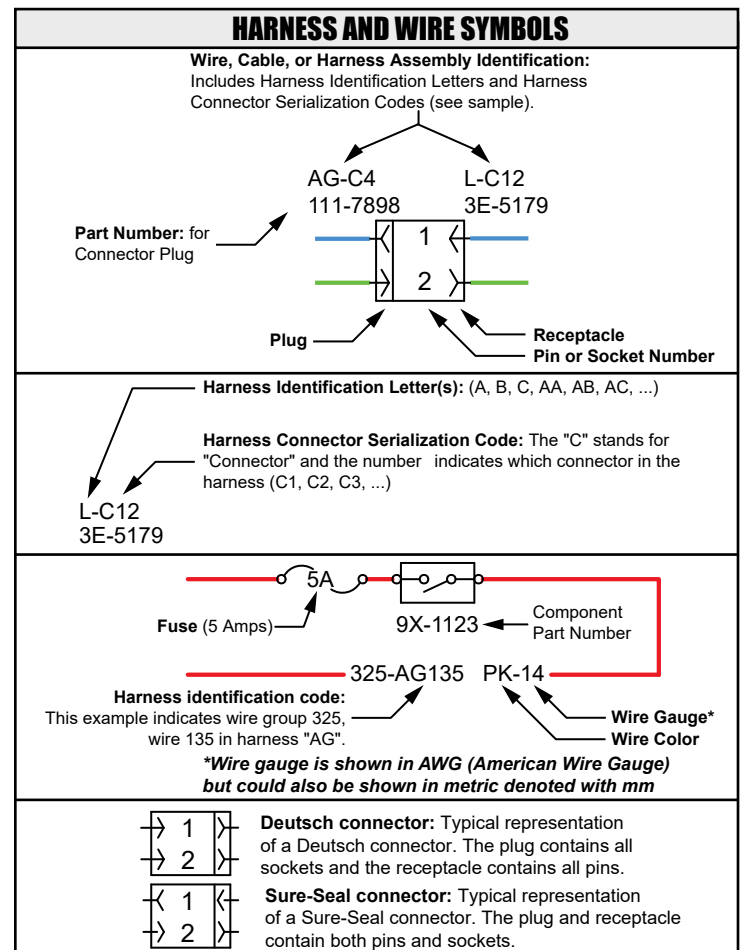
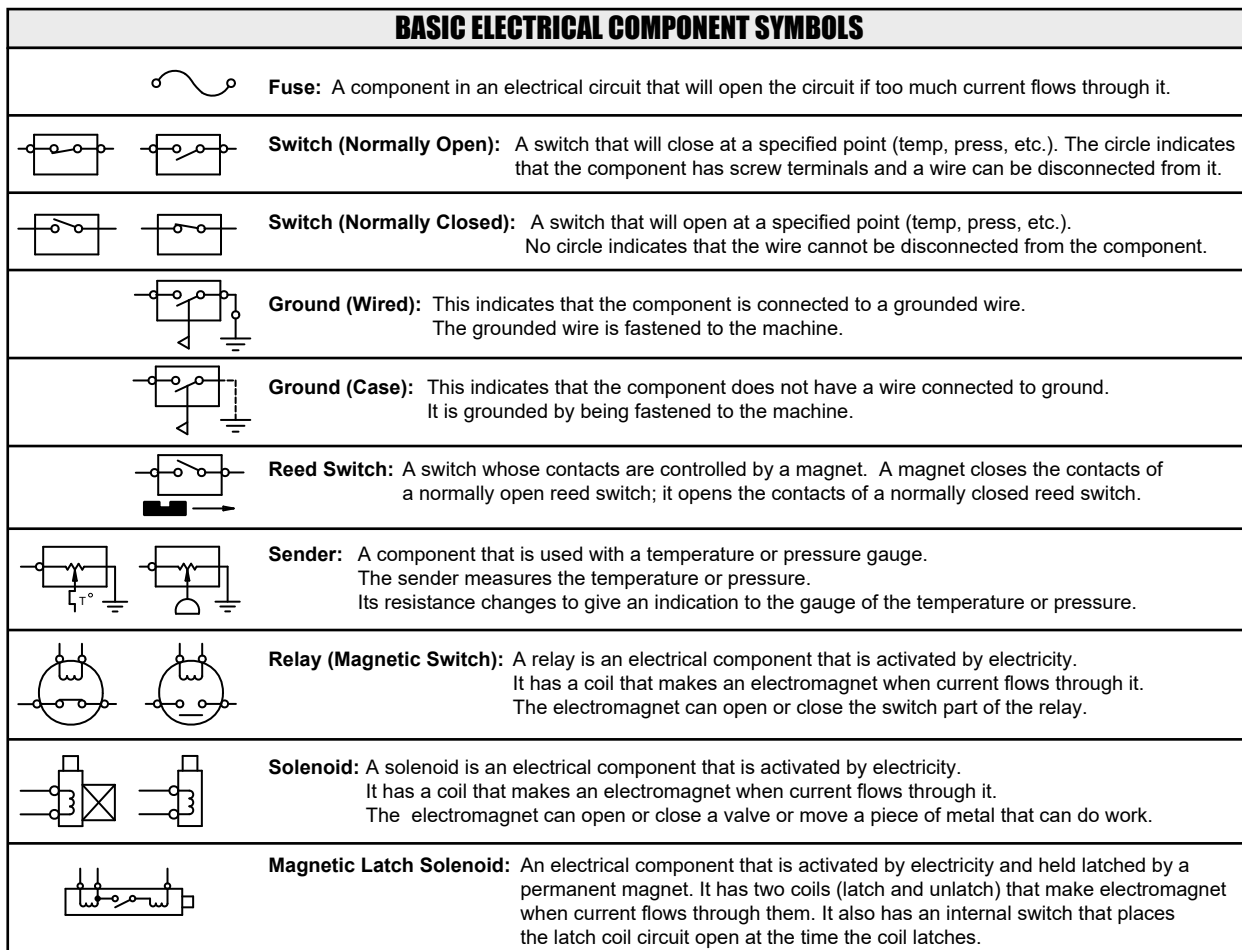
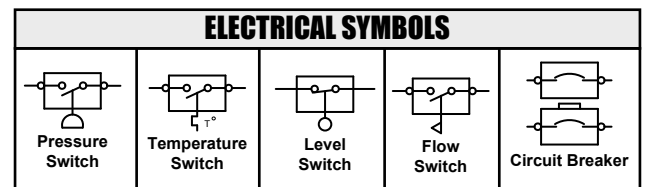
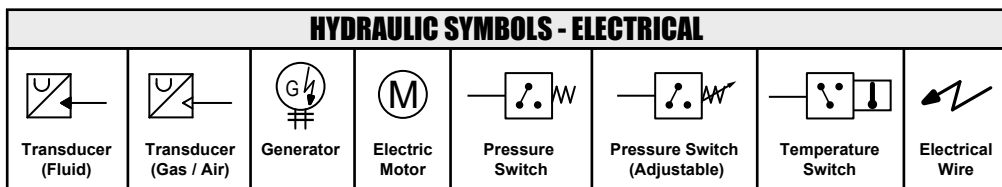
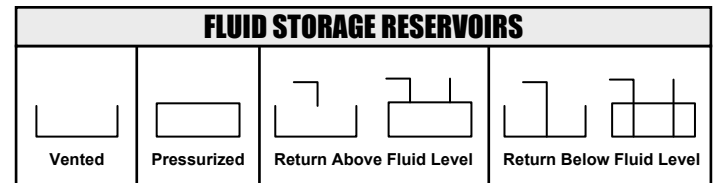
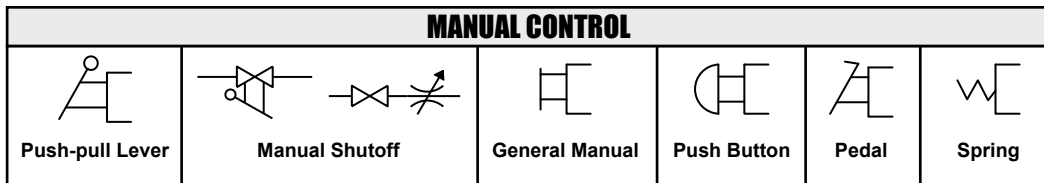
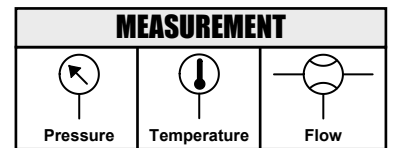
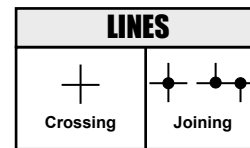
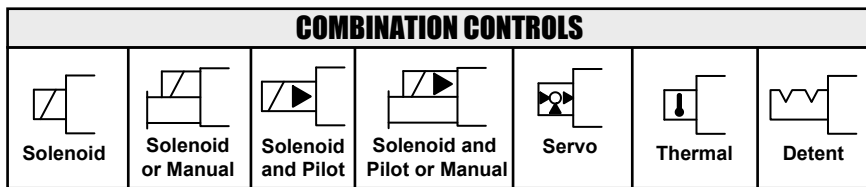
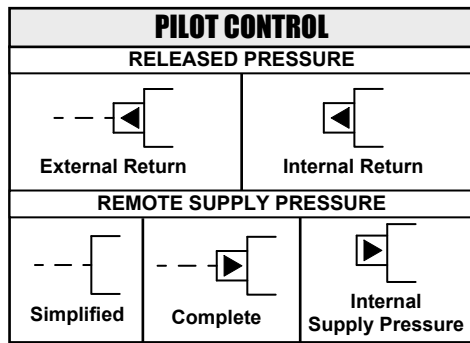
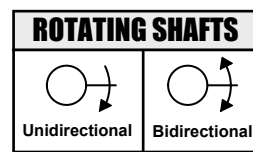
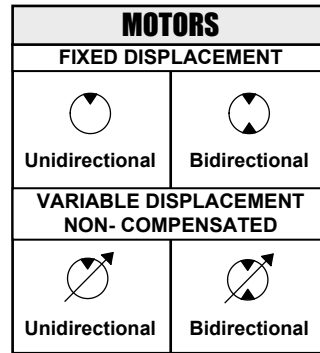
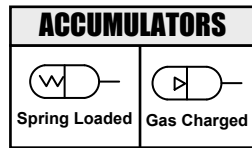
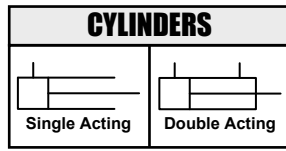
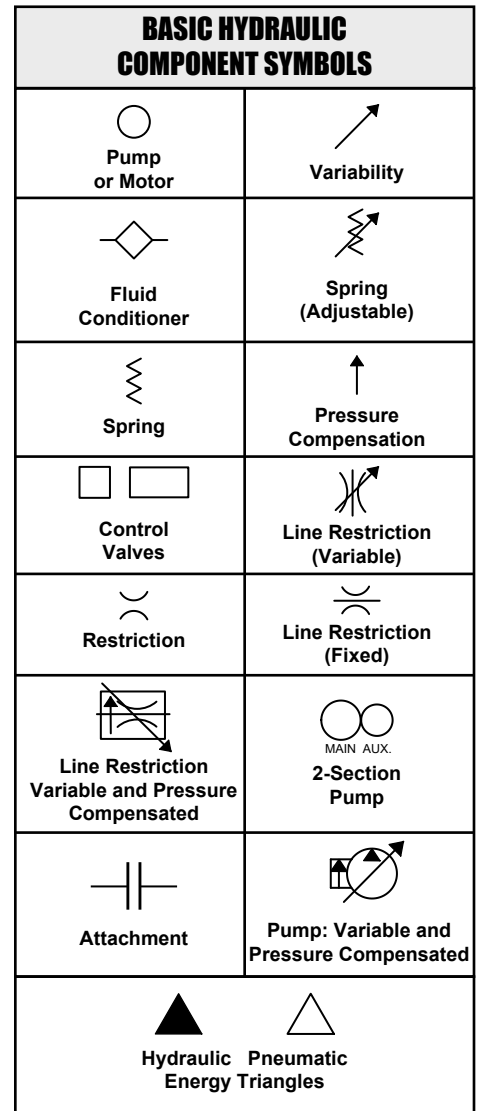
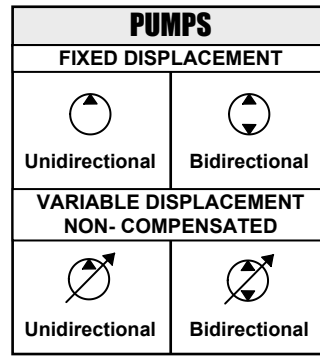
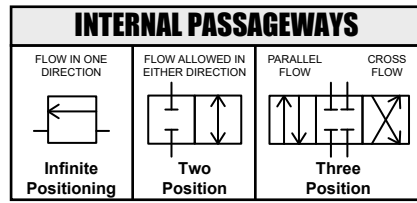
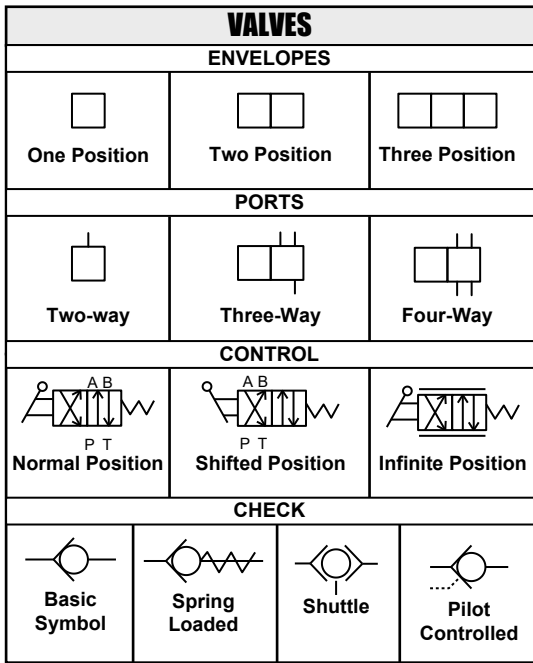



Schematic

C15 Generator Set with EMCP 3 Electrical System

ZKA1-UP
C5E1-UP
FSE1-UP
STG1-UP
C5H1-UP
FFH1-UP
C5L1-UP
NKL1-UP
CYY1-UP

RELATED ELECTRICAL SERVICE MANUALS



TITLE	FORM NUMBER
TROUBLESHOOTING	REN5096
SYSTEMS OPERATION / TESTING AND ADJUSTING	SENR9928
OPERATION & MAINTENANCE MANUAL	SEBU7909
SYSTEMS OPERATION / TESTING AND ADJUSTING (EMCP 3)	REN7902

ANALOG VOLTAGE REGULATOR DIAGRAM (3 PHASE SENSING)

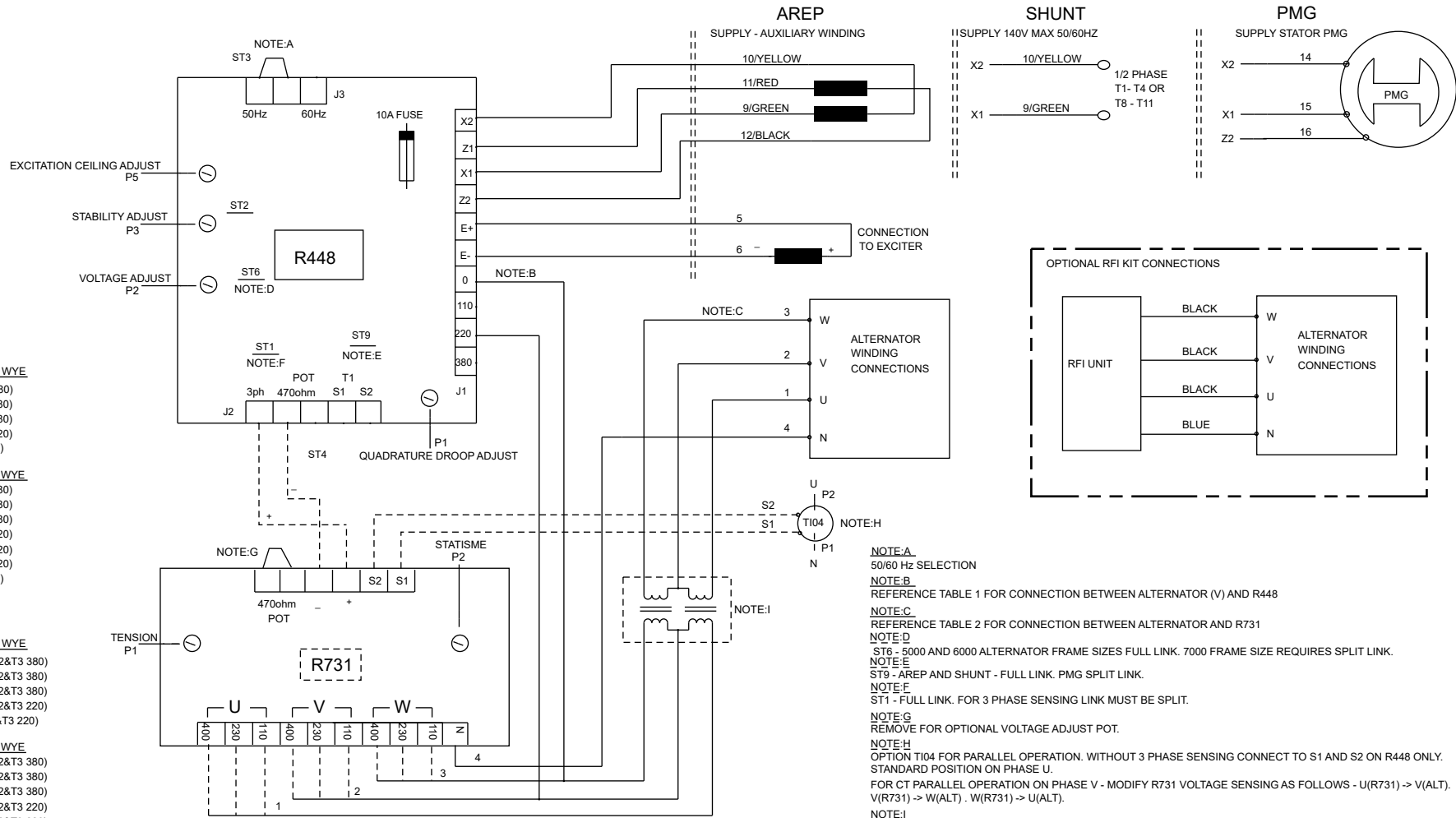

TABLE: 1

50 HZ VOLTAGE WYE

- 415/240V - (T2 380)
- 400/230V - (T2 380)
- 380/220V - (T2 380)
- 220/127V - (T2 220)
- 600V - (T2 220)

60 HZ VOLTAGE WYE

- 480/277V - (T2 380)
- 440/254V - (T2 380)
- 380/220V - (T2 380)
- 240/139V - (T2 220)
- 220/127V - (T2 220)
- 208/120V - (T2 220)
- 600V - (T2 220)

TABLE: 2

50 HZ VOLTAGE WYE

- 415/240V - (T1, T2&T3 380)
- 400/230V - (T1, T2&T3 380)
- 380/220V - (T1, T2&T3 380)
- 220/127V - (T1, T2&T3 220)
- 600V - (T1, T2&T3 220)

60 HZ VOLTAGE WYE

- 480/277V - (T1, T2&T3 380)
- 440/254V - (T1, T2&T3 380)
- 380/220V - (T1, T2&T3 380)
- 240/139V - (T1, T2&T3 220)
- 220/127V - (T1, T2&T3 220)
- 208/120V - (T1, T2&T3 220)
- 600V - (T1, T2&T3 220)

NOTE:A
50/60 Hz SELECTION

NOTE:B
REFERENCE TABLE 1 FOR CONNECTION BETWEEN ALTERNATOR (V) AND R448

NOTE:C
REFERENCE TABLE 2 FOR CONNECTION BETWEEN ALTERNATOR AND R731

NOTE:D
ST6 - 5000 AND 6000 ALTERNATOR FRAME SIZES FULL LINK. 7000 FRAME SIZE REQUIRES SPLIT LINK.

NOTE:E
ST9 - AREP AND SHUNT - FULL LINK. PMG SPLIT LINK.

NOTE:F
ST1 - FULL LINK. FOR 3 PHASE SENSING LINK MUST BE SPLIT.

NOTE:G
REMOVE FOR OPTIONAL VOLTAGE ADJUST POT.

NOTE:H
OPTION T104 FOR PARALLEL OPERATION. WITHOUT 3 PHASE SENSING CONNECT TO S1 AND S2 ON R448 ONLY. STANDARD POSITION ON PHASE U.

FOR CT PARALLEL OPERATION ON PHASE V - MODIFY R731 VOLTAGE SENSING AS FOLLOWS - U(R731) -> V(ALT), V(R731) -> W(ALT), W(R731) -> U(ALT).

NOTE:I
FIT 2 x 5VA TRANSFORMERS FOR 600V OPERATION

ANALOG VOLTAGE REGULATOR DIAGRAM (SINGLE PHASE SENSING)

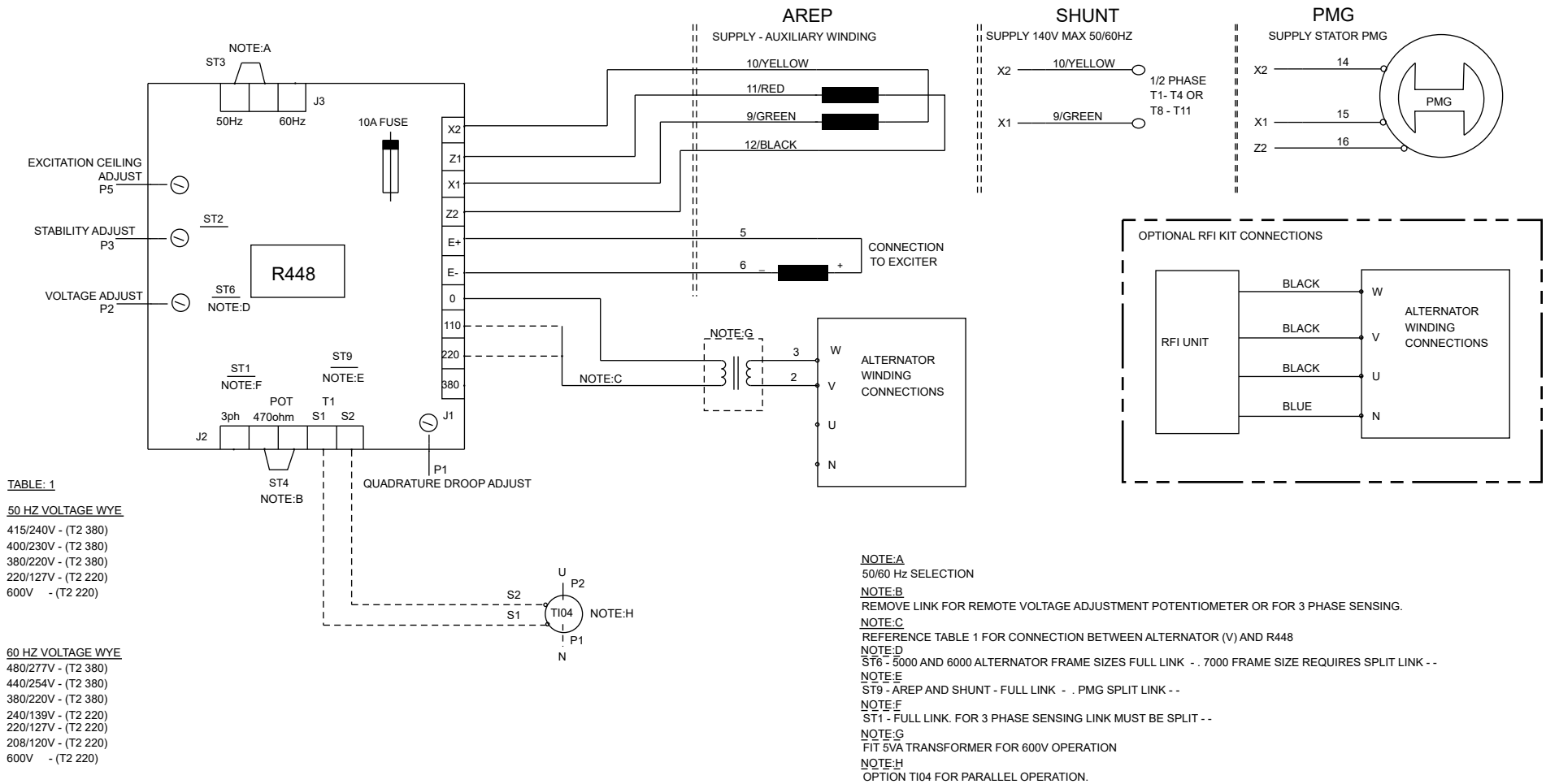

TABLE 1

50 HZ VOLTAGE WYE

- 415/240V - (T2 380)
- 400/230V - (T2 380)
- 380/220V - (T2 380)
- 220/127V - (T2 220)
- 600V - (T2 220)

60 HZ VOLTAGE WYE

- 480/277V - (T2 380)
- 440/254V - (T2 380)
- 380/220V - (T2 380)
- 240/139V - (T2 220)
- 220/127V - (T2 220)
- 208/120V - (T2 220)
- 600V - (T2 220)

- NOTE:A**
50/60 Hz SELECTION
- NOTE:B**
REMOVE LINK FOR REMOTE VOLTAGE ADJUSTMENT POTENTIOMETER OR FOR 3 PHASE SENSING.
- NOTE:C**
REFERENCE TABLE 1 FOR CONNECTION BETWEEN ALTERNATOR (V) AND R448
- NOTE:D**
ST8 - 5000 AND 6000 ALTERNATOR FRAME SIZES FULL LINK - . 7000 FRAME SIZE REQUIRES SPLIT LINK - -
- NOTE:E**
ST9 - AREP AND SHUNT - FULL LINK - . PMG SPLIT LINK - -
- NOTE:F**
ST1 - FULL LINK. FOR 3 PHASE SENSING LINK MUST BE SPLIT - -
- NOTE:G**
FIT 5VA TRANSFORMER FOR 600V OPERATION
- NOTE:H**
OPTION T104 FOR PARALLEL OPERATION.

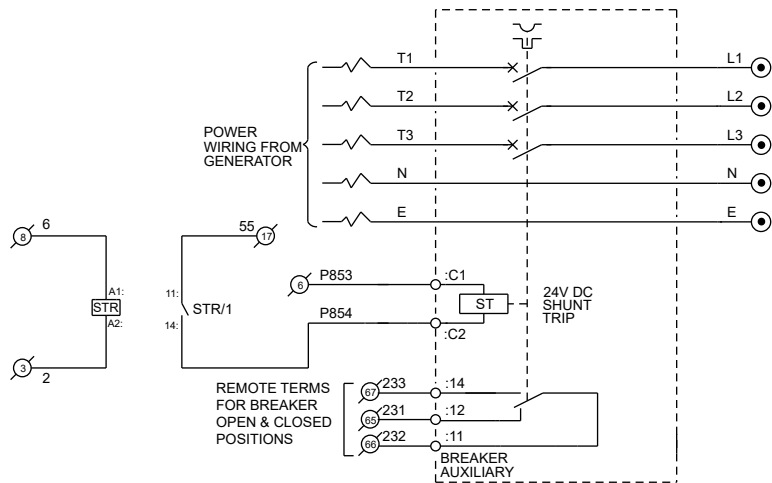

MERLIN GERIN BREAKER

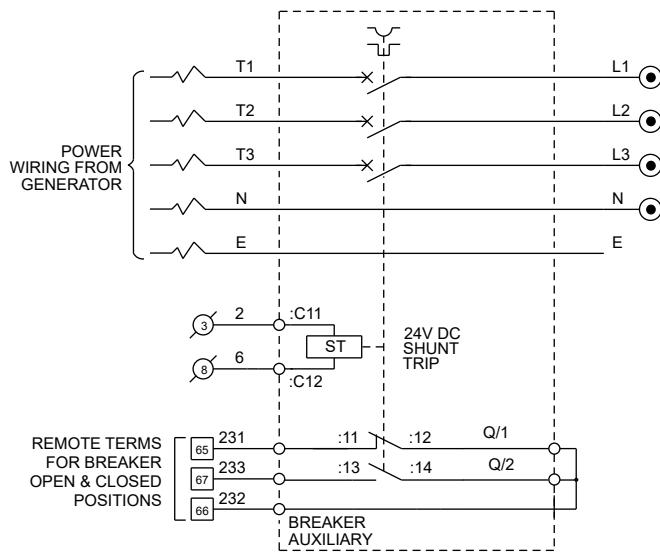

MCCB

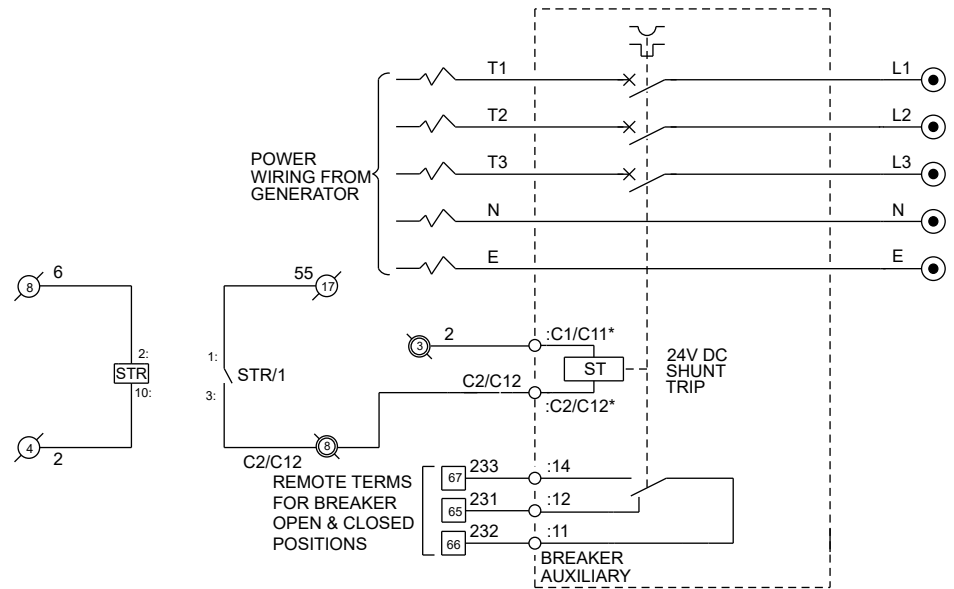

* C1 & C2 CONNECTIONS ON T5 (630A) & T6 (800A) BREAKERS
C11 & C12 CONNECTIONS ON T7 (1250A & 1600A) BREAKERS

ACB

CAT DIGITAL VOLTAGE REGULATOR (CDVR)

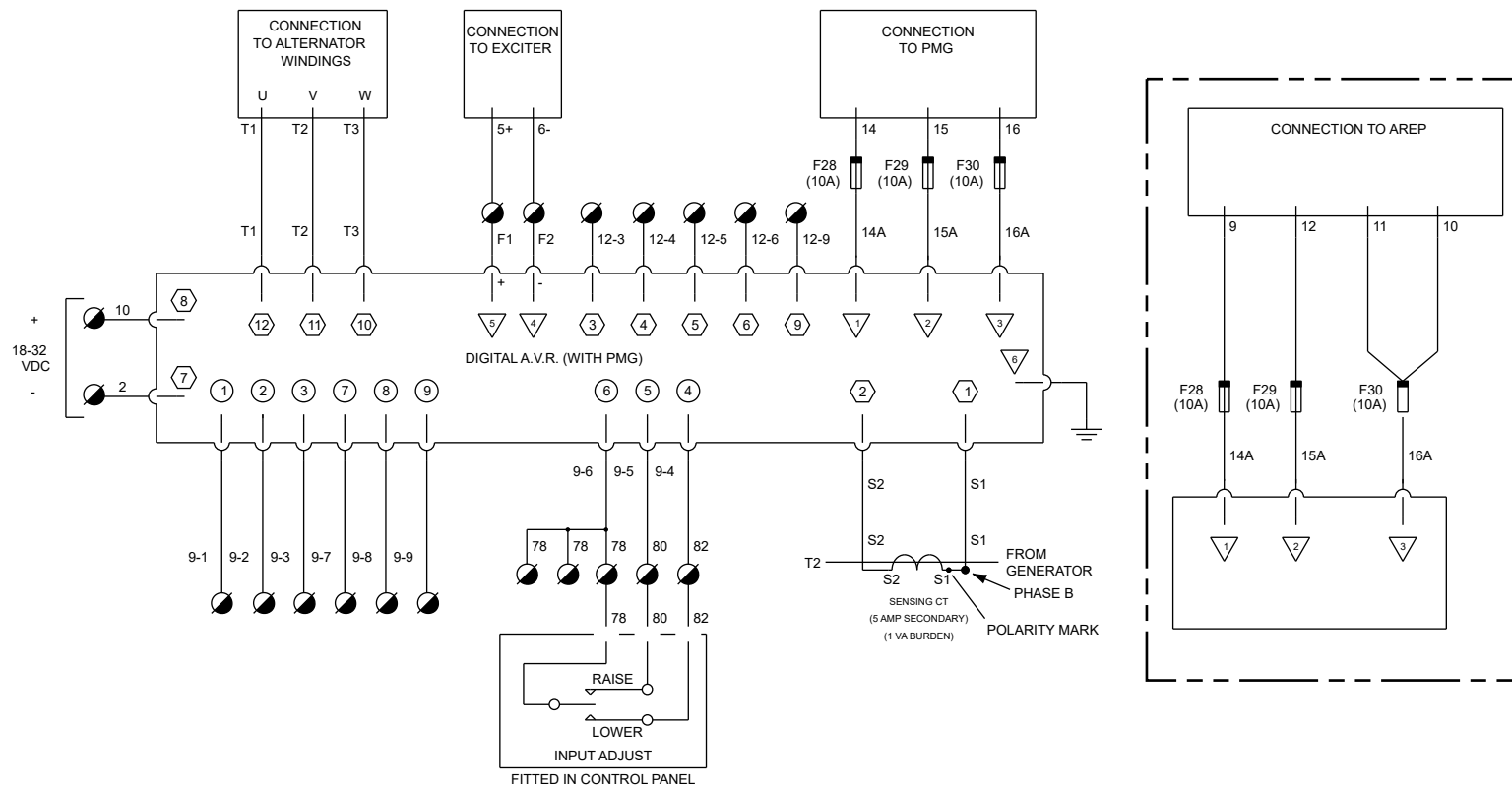

DISCREET I/O MODULE

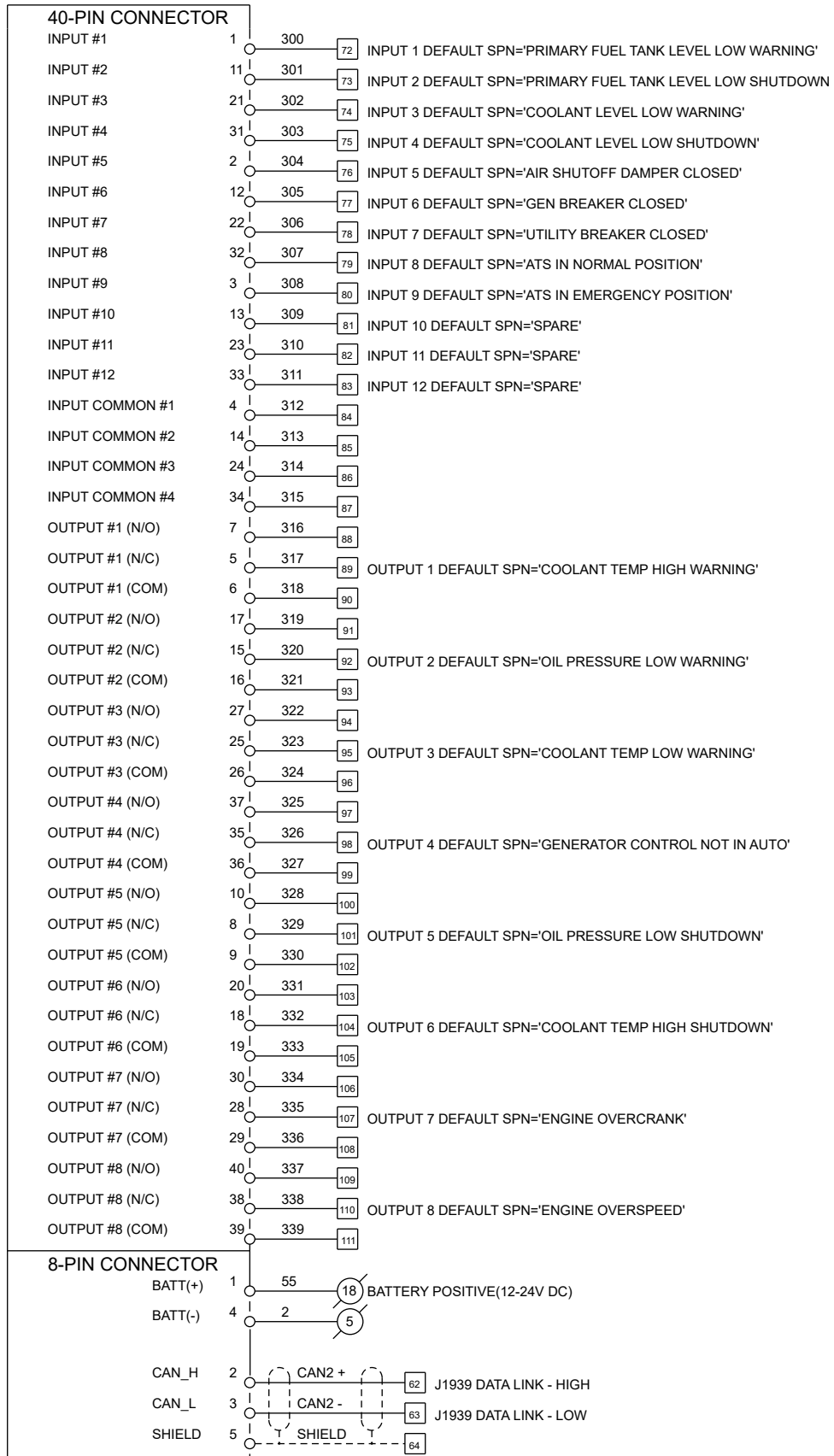

FUEL TRANSFER PUMP CIRCUIT



PUMPED FUEL SUPPLY FROM BELOW FLOOR LEVEL BULK TANK TO BASE TANK
- FUEL SYSTEM No. 1

OR

FUEL PUMPED FROM FREE STANDING BULK TANK - FUEL SYSTEM NO. 3

DC CIRCUIT

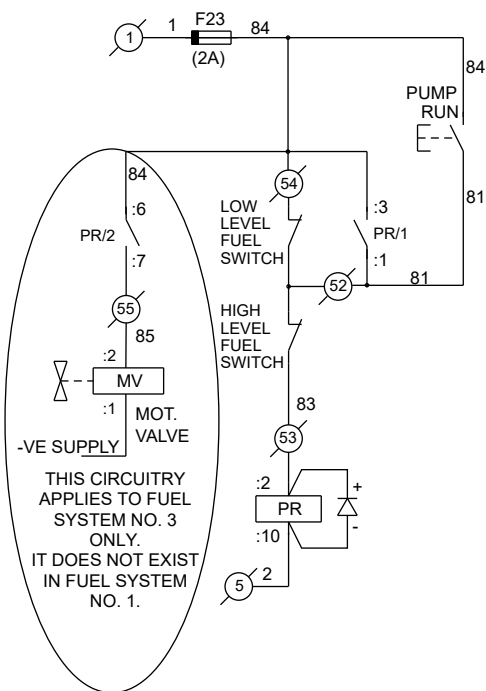

AC CIRCUIT

NOTE:B

IF 120V FUEL TRANSFER PUMP IS FITTED FUSE F21 SHOULD BE 10A
IF 230V FUEL TRANSFER PUMP IS FITTED FUSE F21 SHOULD BE 6A

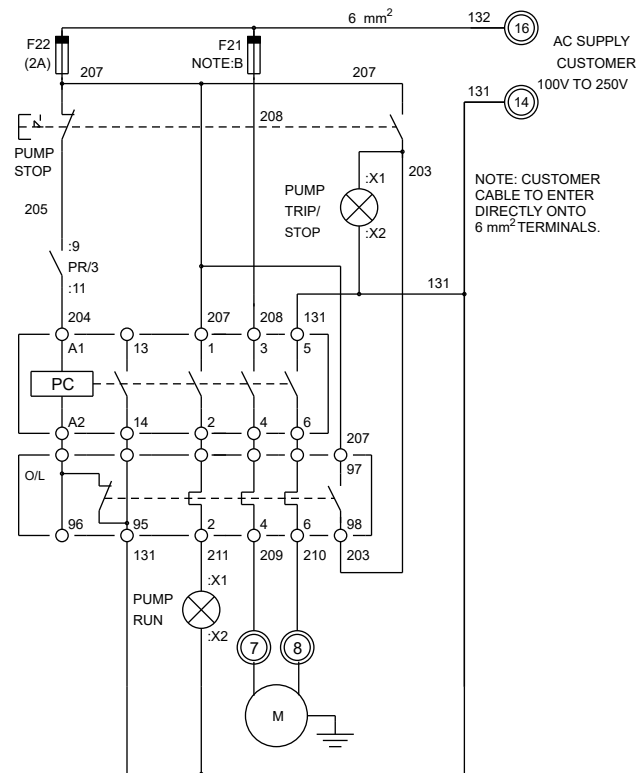

RTD AND THERMOCOUPLE MODULE

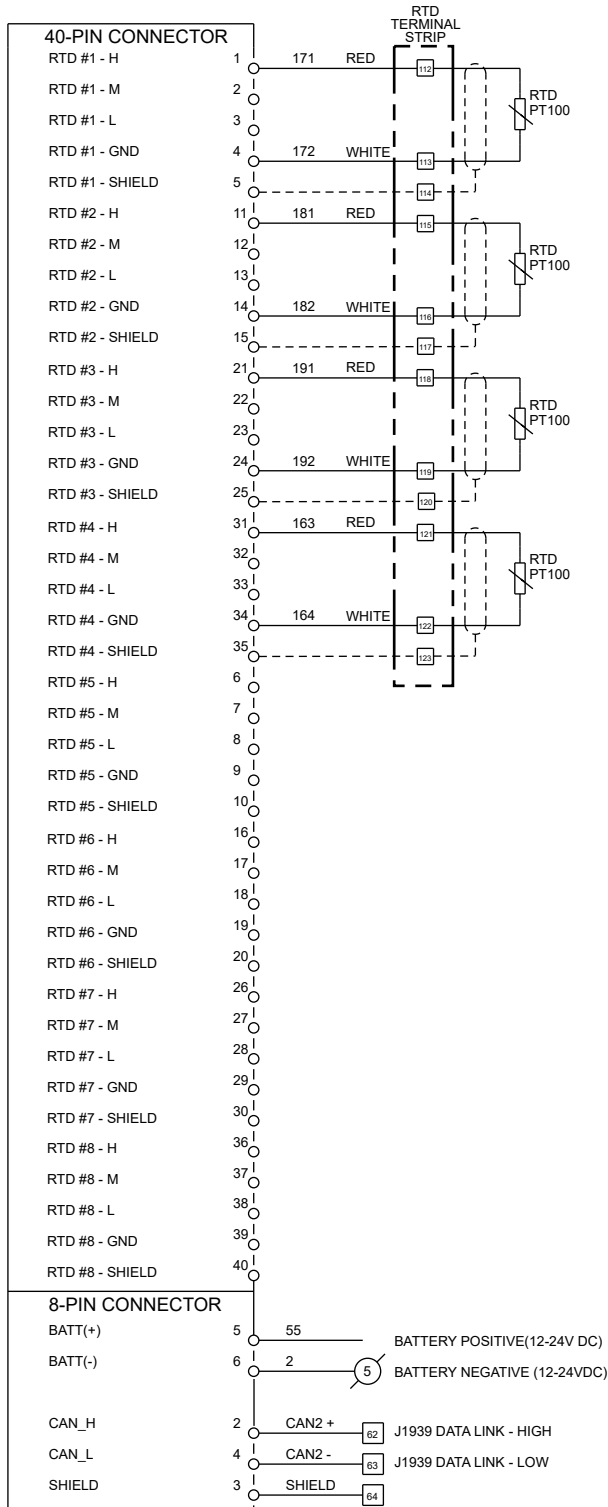

RTD MODULE

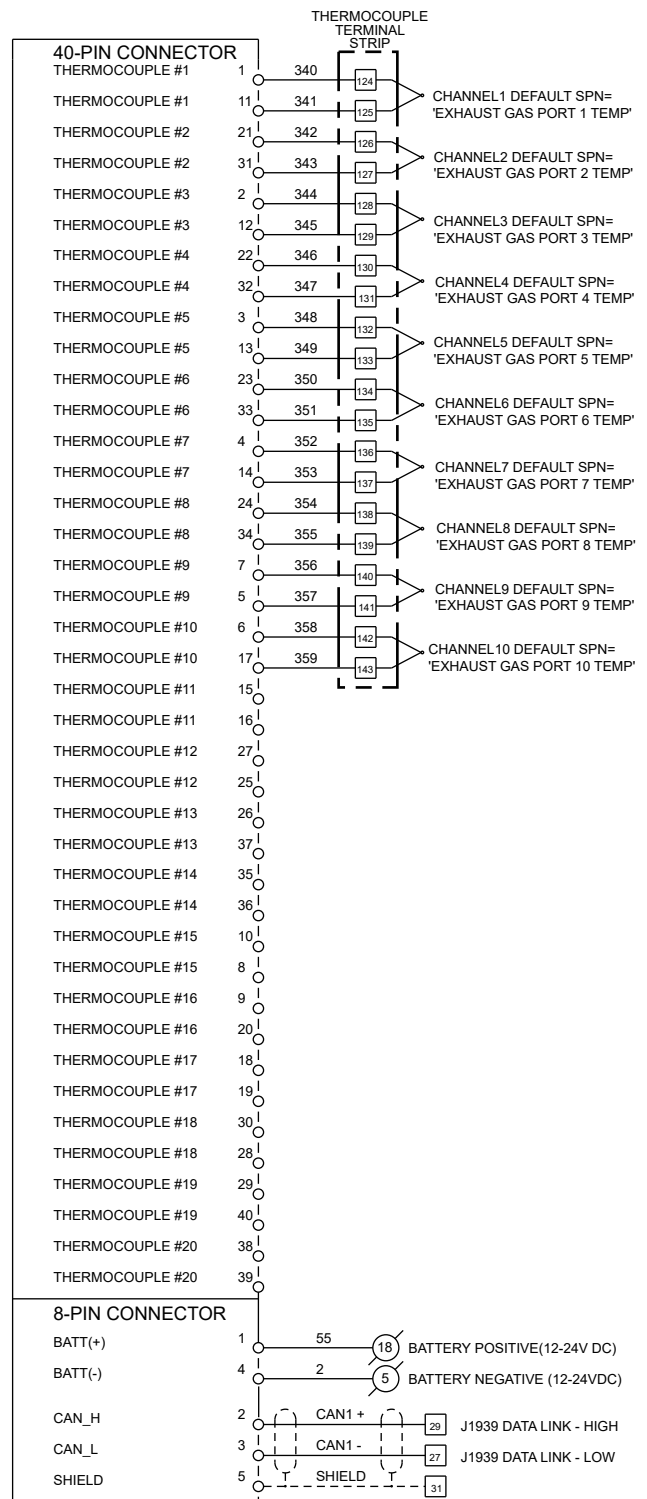

THERMOCOUPLE MODULE

FAILURE MODE IDENTIFIER (FMI) CODES



Description	FMI
Data Valid but Above Normal Operational Range- Most Severe Level	0
Data Valid but Below Normal Operational Range- Most Severe Level	1
Data Erratic, Intermittent or Incorrect	2
Voltage Above Normal or Shorted to High Source	3
Voltage Below Normal or Shorted to Low Source	4
Current Below Normal or Grounded Circuit	5
Current Above Normal or Grounded Circuit	6
Mechanical System Not Responding or Out of Adjustment	7
Abnormal Frequency, Pulse Width or Period	8
Abnormal Update Rate	9
Abnormal Rate of Change	10
Unexpected Engine Shutdown	11
Bad Intelligent Device or Component	12
Out of Calibration	13
Special Instructions	14
Data Valid But Above Normal Operational Range- Least Severe Level	15
Data Valid But Above Normal Operational Range- Moderately Severe Level (Derate)	16
Data Valid But Below Normal Operational Range- Least Severe Level	17
Data Valid But Below Normal Operational Range- Moderately Severe Level (Derate)	18
Received Network Data In Error	19
Not Available or Condition Exists	31

SUSPECT PARAMETER NUMBER (SPN)



Suspect Parameter Number (SPN)	
SPN Description	SPN
Fuel Level (External Tank)	38
Aftercooler Temperature	52
Starting Air Pressure	82
Fuel Pressure	94
Fuel Filter Differential Pressure	95
Fuel Level (Local Tank)	96
Engine Oil Level	98
Oil Filter Differential Pressure	99
Engine Oil Pressure	100
Crankcase Pressure	101
Intake Manifold 1 Temperature	105
Air Filter Differential Pressure	107
Atmospheric Pressure	108
Engine Coolant Temperature	110
Engine Coolant Level	111
Fire Extinguisher Pressure	137
Battery Voltage (switch)	158
Battery Charging System Voltage	167
Battery Voltage	168
Ambient Air Temperature	171
Inlet Air Temperature	172
Exhaust Temperature	173
Fuel Temperature	174
Engine Oil Temperature	175
Turbo Oil Temperature	176
Engine Speed	190
Auxiliary Temperature 1	441
Auxiliary Temperature 2	442
Generator Rotating Diode Failure	612
SCADA Data Link Fault	625
Voltage Regulator Failure	628
Primary Data Link (J1939 #1)	639
Event Input Function #1	701
Event Input Function #2	702

Suspect Parameter Number (SPN)	
SPN Description	SPN
Event Input Function #3	703
Event Input Function #4	704
Event Input Function #5	705
Event Input Function #6	706
Event Input Function #7	707
Event Input Function #8	708
Event Input Function #9	709
Event Input Function #10	710
Event Input Function #11	711
Event Input Function #12	712
Event Input Function #13	713
Event Input Function #14	714
Event Input Function #15	715
Event Input Function #16	716
Emergency Stop Switch	970
Engine Derate Overridden	971
Generator Bearing Temperature #1	1122
Generator Bearing Temperature #2	1123
Generator Winding Temperature #1	1124
Generator Winding Temperature #2	1125
Generator Winding Temperature #3	1126
Intake Manifold 2 Temperature	1131
Intake Manifold 3 Temperature	1132
Intake Manifold 4 Temperature	1133
Engine Oil Temperature 2	1135
Exhaust Gas Port 1 Temperature	1137
Exhaust Gas Port 2 Temperature	1138
Exhaust Gas Port 3 Temperature	1139
Exhaust Gas Port 4 Temperature	1140
Exhaust Gas Port 5 Temperature	1141
Exhaust Gas Port 6 Temperature	1142
Exhaust Gas Port 7 Temperature	1143
Exhaust Gas Port 8 Temperature	1144
Exhaust Gas Port 9 Temperature	1145

Suspect Parameter Number (SPN)	
SPN Description	SPN
Exhaust Gas Port 10 Temperature	1146
Exhaust Gas Port 11 Temperature	1147
Exhaust Gas Port 12 Temperature	1148
Exhaust Gas Port 13 Temperature	1149
Exhaust Gas Port 14 Temperature	1150
Exhaust Gas Port 15 Temperature	1151
Exhaust Gas Port 16 Temperature	1152
Exhaust Gas Port 17 Temperature	1153
Exhaust Gas Port 18 Temperature	1154
Exhaust Gas Port 19 Temperature	1155
Exhaust Gas Port 20 Temperature	1156
Main Bearing 1 Temperature (engine)	1157
Main Bearing 2 Temperature (engine)	1158
Main Bearing 3 Temperature (engine)	1159
Main Bearing 4 Temperature (engine)	1160
Main Bearing 5 Temperature (engine)	1161
Main Bearing 6 Temperature (engine)	1162
Main Bearing 7 Temperature (engine)	1163
Main Bearing 8 Temperature (engine)	1164
Main Bearing 9 Temperature (engine)	1165
Main Bearing 10 Temperature (engine)	1166
Main Bearing 11 Temperature (engine)	1167
Turbocharger 1 Compressor Inlet Temperature	1172
Turbocharger 2 Compressor Inlet Temperature	1173
Turbocharger 3 Compressor Inlet Temperature	1174
Turbocharger 4 Compressor Inlet Temperature	1175
Turbocharger 1 Turbine Inlet Temperature	1180
Turbocharger 2 Turbine Inlet Temperature	1181
Turbocharger 3 Turbine Inlet Temperature	1182
Turbocharger 4 Turbine Inlet Temperature	1183
Turbocharger 1 Turbine Outlet Temperature	1184
Turbocharger 2 Turbine Outlet Temperature	1185
Turbocharger 3 Turbine Outlet Temperature	1186
Turbocharger 4 Turbine Outlet Temperature	1187

Suspect Parameter Number (SPN)	
SPN Description	SPN
Engine Auxiliary Coolant Temperature	1212
Accessory Data Link Fault (J1939 #2)	1231
Emergency Shutdown Override Mode Active Warning	1237
Ruptured Fuel Basin- Primary Tank	1239
Unexpected Engine Shutdown	1383
Engine Failure to Start Shutdown	1664
Battery 1 Temperature	1800
Battery 2 Temperature	1801
Intake Manifold 5 Temperature	1802
Intake Manifold 6 Temperature	1803
Right Exhaust Temperature	2433
Left Exhaust Temperature	2434
Generator Frequency	2436
Generator AC Voltage	2440
Generator AC Current	2448
Generator Reverse Power (kW)	2452
Generator Reverse Power (kVAr)	2456
Service Interval Warning	2648
Air Damper Closed	4000
ATS in Normal Position	4001
ATS in Emergency Position	4002
Battery Charger Failure	4003
Generator Breaker Closed	4004
Utility Breaker Closed	4005
Engine in Cooldown	4006
Generator Control Not in Automatic Warning	4007
Generator Breaker Failure to Open	4009
Utility Breaker Failure to Open	4010
Generator Breaker Failure to Close	4011
Utility Breaker Failure to Open	4010
Generator Breaker Failure to Close	4011
Utility Breaker Failure to Close	4012
Utility to Generator Transfer Failure Warning	4015
Generator to Utility Transfer Failure Warning	4016
Loss of Utility	4017
Earth Fault	4028
Earth Leakage	4029

CONTROL PANEL



EMCP 4.1/4.2 CONTROLLER

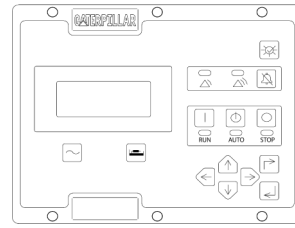

PANEL LIGHT SWITCH

START AID
AUTO/MANUAL
SWITCH
(OPTIONAL)

EMERGENCY
STOP PUSH
BUTTON

VOLTAGE ADJUST SWITCH

SPEED
POTENTIOMETER
(OPTIONAL)

REAR VIEW

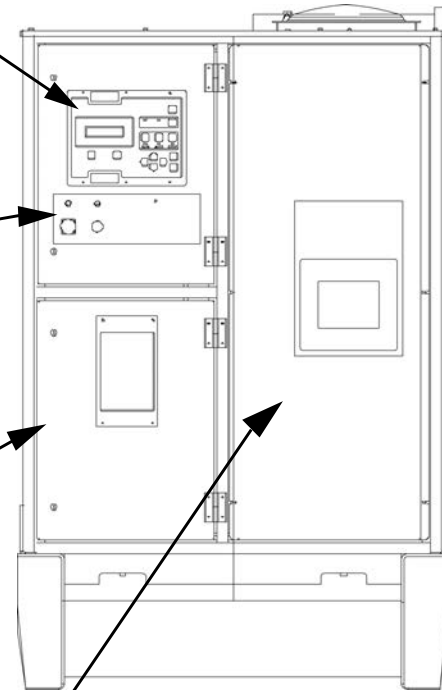

PUMP STOP
SWITCH
(IF EQUIPPED)

PUMP RUN
SWITCH
(IF EQUIPPED)

AUDIBLE ALARM

POWER
DISTRIBUTION
PANEL

CUSTOMER
SERVICE
CONNECTOR

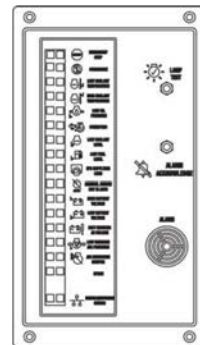

ANNUNCIATOR PANEL

ENGINE LEFT SIDE VIEW

