

MCM - 120-PIN CONNECTOR

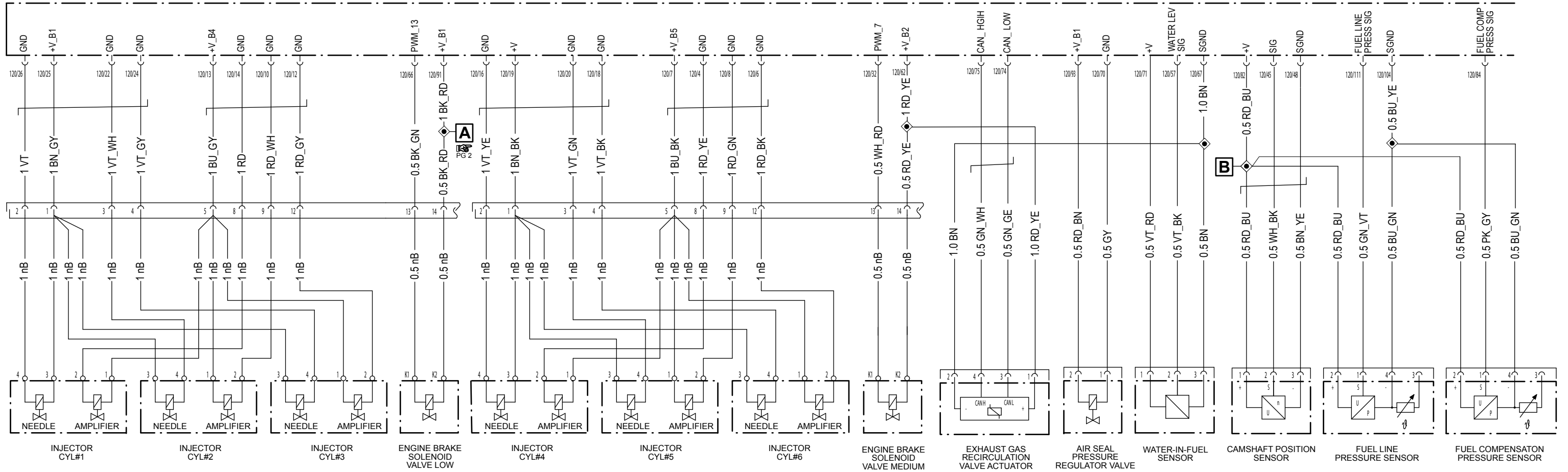

MCM - 120-PIN CONNECTOR

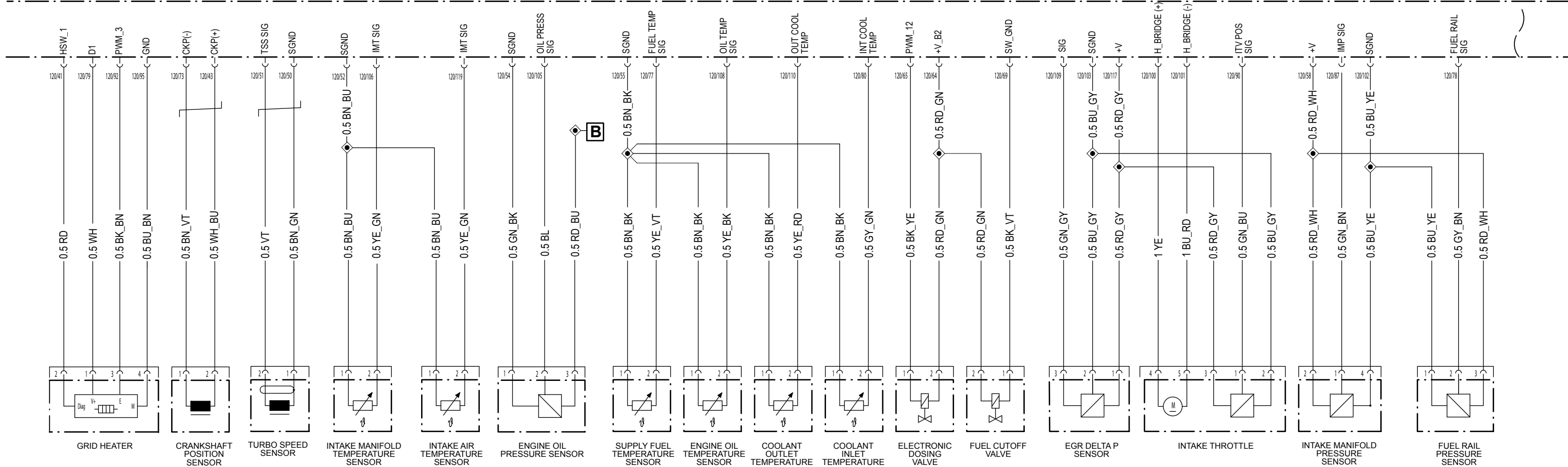

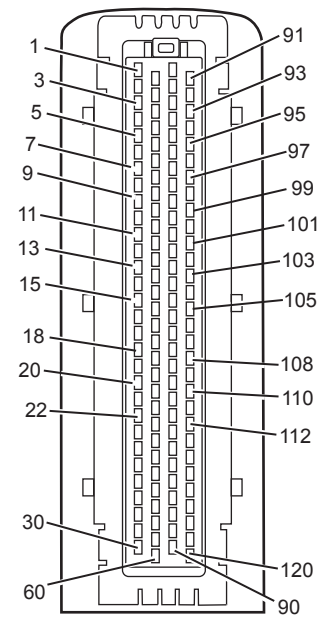

120-PIN CONNECTOR

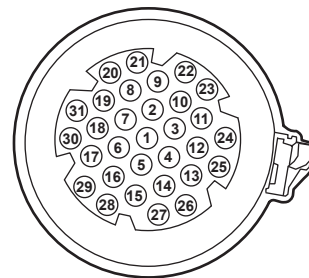

FRONT
LOOKING INTO PINS
ON THE HARNESS

31-PIN CONNECTOR

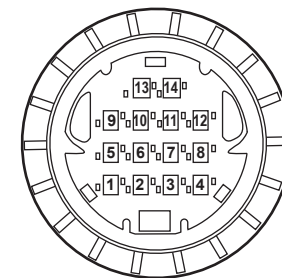

**ENGINE HARNESS
SIDE**

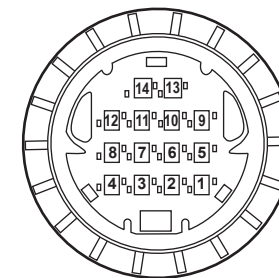

**VALVE COVER
SIDE**

14-PIN INJECTOR HARNESS CONNECTOR

MCM - 120-PIN CONNECTOR

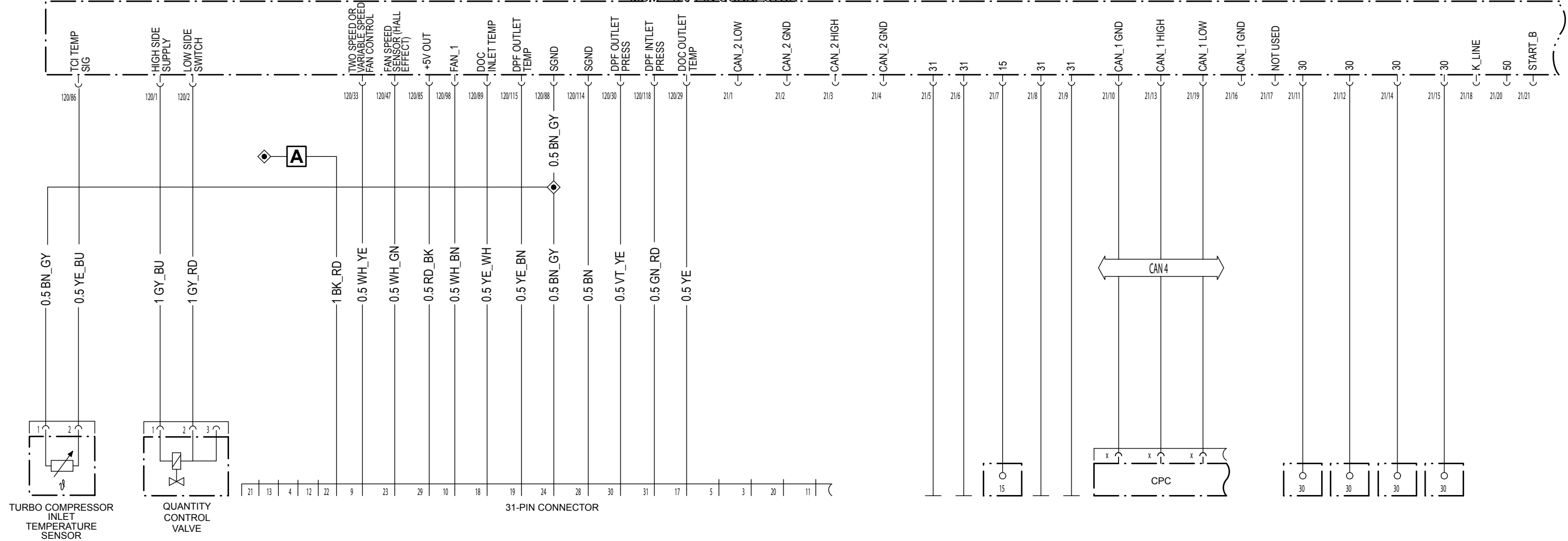

DD15 2007 ENGINE HARNESS (continued)

All information subject to change without notice. (Rev. 2/08)
802 Copyright © 2008 DETROIT DIESEL CORPORATION