

3 HARDWARE AND WIRING

Section	Page
3.1 SUPPLIED HARDWARE	3-3
3.2 ELECTRONIC CONTROL MODULE	3-5
3.3 ENGINE SENSOR HARNESS	3-9
3.4 VEHICLE INTERFACE HARNESS	3-15
3.5 COMMUNICATION HARNESS	3-35
3.6 INJECTOR HARNESS	3-37
3.7 POWER HARNESS	3-39
3.8 POWER SUPPLY	3-47
3.9 FUSES	3-51
3.10 CONNECTORS	3-53
3.11 WIRES AND WIRING	3-67
3.12 CONDUIT AND LOOM	3-97
3.13 TAPE AND TAPING	3-99
3.14 SENSORS	3-101
3.15 THROTTLE DEVICES	3-139
3.16 LIGHTS	3-141

THIS PAGE INTENTIONALLY LEFT BLANK

3.1 SUPPLIED HARDWARE

Hardware supplied by the Original Equipment Manufacturer (OEM) and DDC is required to install DDEC IV. The following sections list the minimum hardware required.

3.1.1 OEM-SUPPLIED HARDWARE

The minimum OEM-supplied hardware required is listed in Table 3-1.

Hardware	Description
Ignition Switch (refer to section 3.4.3)	Switched 12/24 volt ignition source
Vehicle Interface Harness (VIH) (refer to section 3.4)	Connects the vehicle functions to the ECM.
Communication Harness (refer to section 3.5)	Connects the ECM's SAE J1922 Data Link and SAE J1939 Data Link to other vehicle systems.
Power Harness (refer to section 3.7)	Connects battery power (12/24 volts) and ground to the ECM and includes fuse(s) or circuit breaker(s).
Power to EGR and VNT Systems (refer to section 3.4.5)	Connects ignition power and battery ground to the EGR and VNT.
Diagnostic Connector (refer to section 3.10.4)	Cab-mounted diagnostic connector
Throttle Input Device (refer to section 3.15)	An electronic foot pedal assembly (EFPA), hand throttle, or alternative throttle device
Coolant Level Sensor (CLS) (refer to section 3.14.18)	A radiator top tank or remote surge tank mounted sensor
Check Engine Light (CEL) (refer to section 3.16.1)	A panel mounted yellow indicator light.
Stop Engine Light (SEL) (refer to section 3.16.2)	A panel mounted red indicator light.

Table 3-1 OEM-supplied Hardware

3.1.2 DDC-SUPPLIED HARDWARE

The minimum DDC-supplied hardware required is listed in Table 3-2.

Hardware	Description
Engine Sensor Harness (refer to section 3.3)	Factory installed harness that facilitates the receipt of input and output signal, controlling the fuel injection process and engine speed.
Injector Harness (refer to section 3.6)	Factory installed harness that is connected to the injectors and the ECM.
Engine Sensors (refer to section 3.14.1)	Various engine mounted sensors for engine control.
Electronic Control Module (ECM) (refer to section 3.2)	Engine mounted ECM provides control logic to provide overall engine management.
Relative Humidity/Turbo Compressor Inlet (TCI) Temperature Sensor (refer to section 3.14.23)	Sensor to measure turbo compressor inlet temperature and relative humidity. Must be installed by OEM.

Table 3-2 Minimum DDC Supplied Hardware

THIS PAGE INTENTIONALLY LEFT BLANK

3.2 ELECTRONIC CONTROL MODULE

The engine-mounted ECM includes control logic to provide overall engine management. The ECM continuously performs self diagnostic checks and monitors other system components. System diagnostic checks are made at ignition-on and continue throughout all engine operating modes. See Figure 3-1.

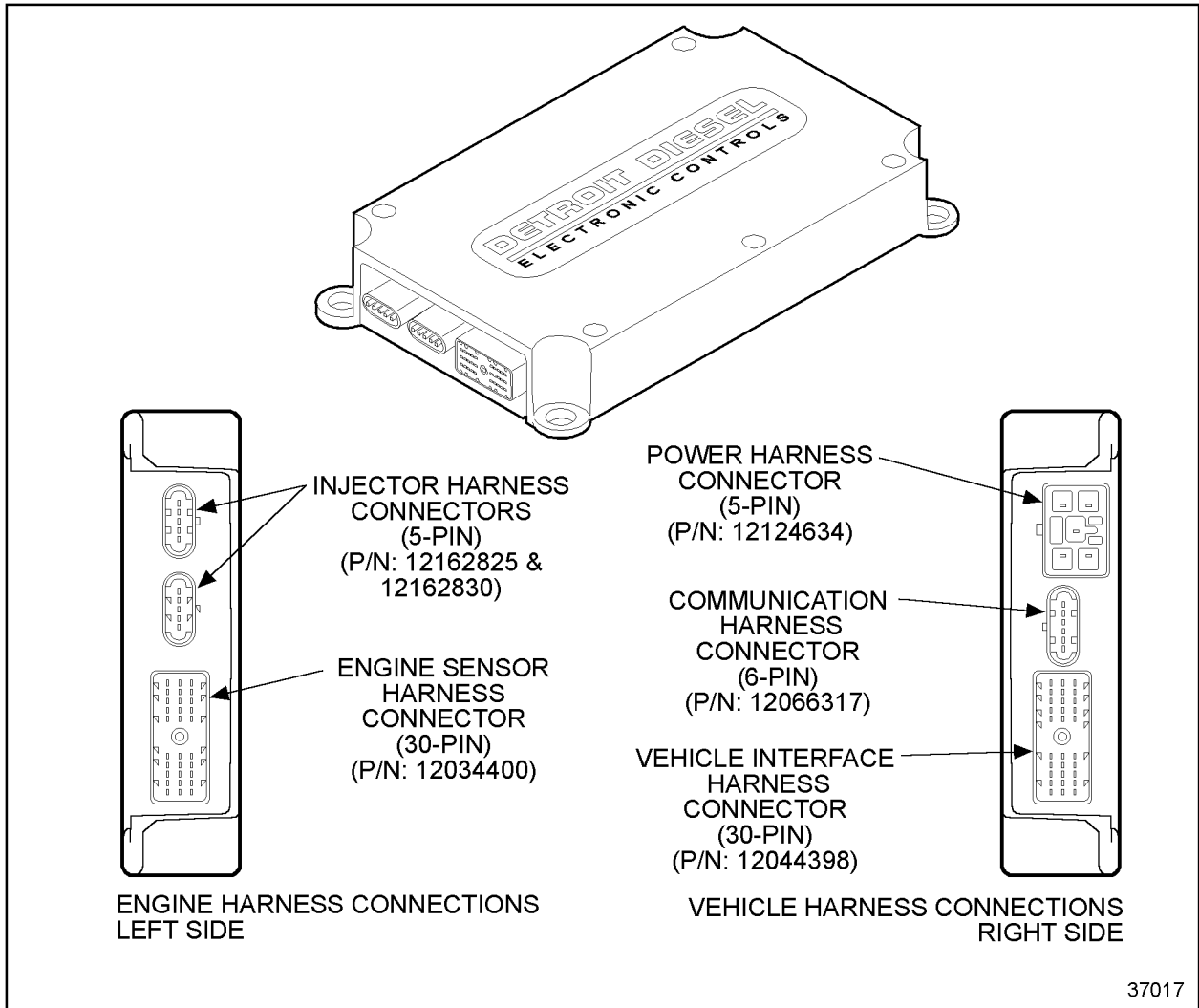

Figure 3-1 The Electronic Control Module

The ECM contains an Electronically Erasable Programmable Read Only Memory (EEPROM). The EEPROM controls the basic engine functions, such as rated speed and power, timing of fuel injection, engine governing, torque shaping, cold start logic, transient fuel delivery, diagnostics, and engine protection. The control logic determines duration and timing of fueling, which results in precise fuel delivery and improved fuel economy.

3.2.1 ECM PART NUMBERS

Part numbers for DDEC IV ECMs are listed in Table 3-3.

Part Number	Description	Voltage	No. of Cylinders
23519307	DDEC IV - Standard On-highway ECM	12 V	6
23519308	DDEC IV - Universal ECM	12/24 V	8

Table 3-3 ECM Part Numbers for DDEC IV

The part numbers for the ECM connectors are listed in Table 3-4.

Description	Part Number
Injector Harness Connectors (5-pin) (2 connectors)	12162825
	12162830
Engine Sensor Harness Connector (30-pin)	12034400
Power Harness Connector (5-pin)	12124634
Communication Harness Connector (6-pin)	12066317
Vehicle Interface Harness Connector (30-pin)	12044398

Table 3-4 ECM Connectors

For more information on the ECM connectors, refer to section 3.10.

3.2.2 ENVIRONMENTAL CONDITIONS

The following environmental conditions must be considered.

Temperature

The ambient operating temperature is -40°F (-40°C) minimum and 221°F (105°C) maximum.

Atmospheric Pressure

The engine mounted ECM can withstand atmospheric pressures ranging from 62.0 to 120.0 kPa absolute that result from altitude and weather changes in the operating and non-operating conditions.

Water Intrusion

The ECM can be exposed to steam cleaning and pressure washing. Care should be taken not to pressure spray the connectors.

THIS PAGE INTENTIONALLY LEFT BLANK

3.3 ENGINE SENSOR HARNESS

The Engine Sensor Harness (ESH) is installed at the factory and is delivered connected to all engine sensors and the ECM. See Figure 3-2 for an illustration of a typical on-highway ESH for the Series 60 and Figure 3-3 for the Series 50. Refer to Appendix B for a harness schematic.

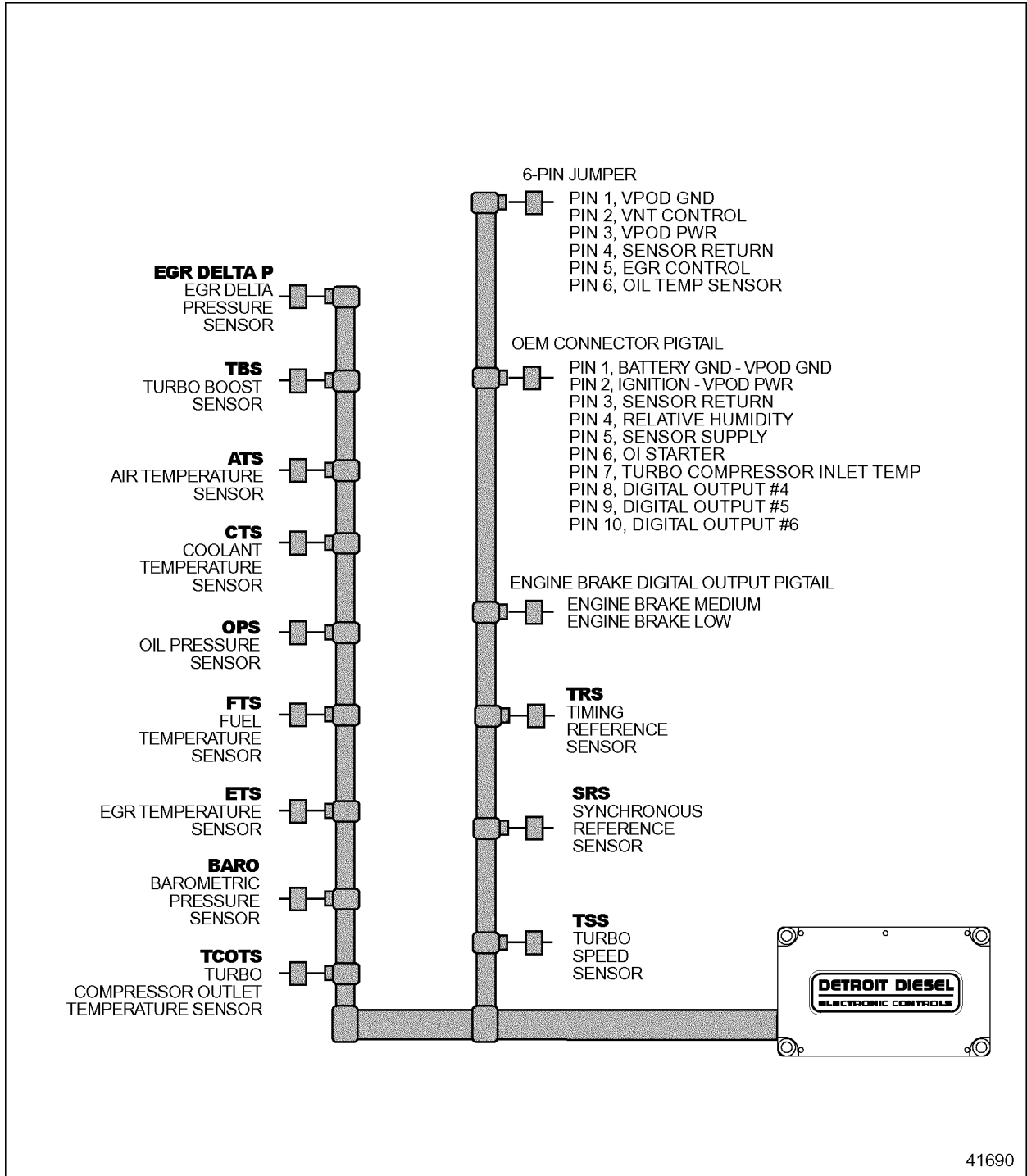

Figure 3-2 A Typical On-highway Engine Sensor Harness — Series 60

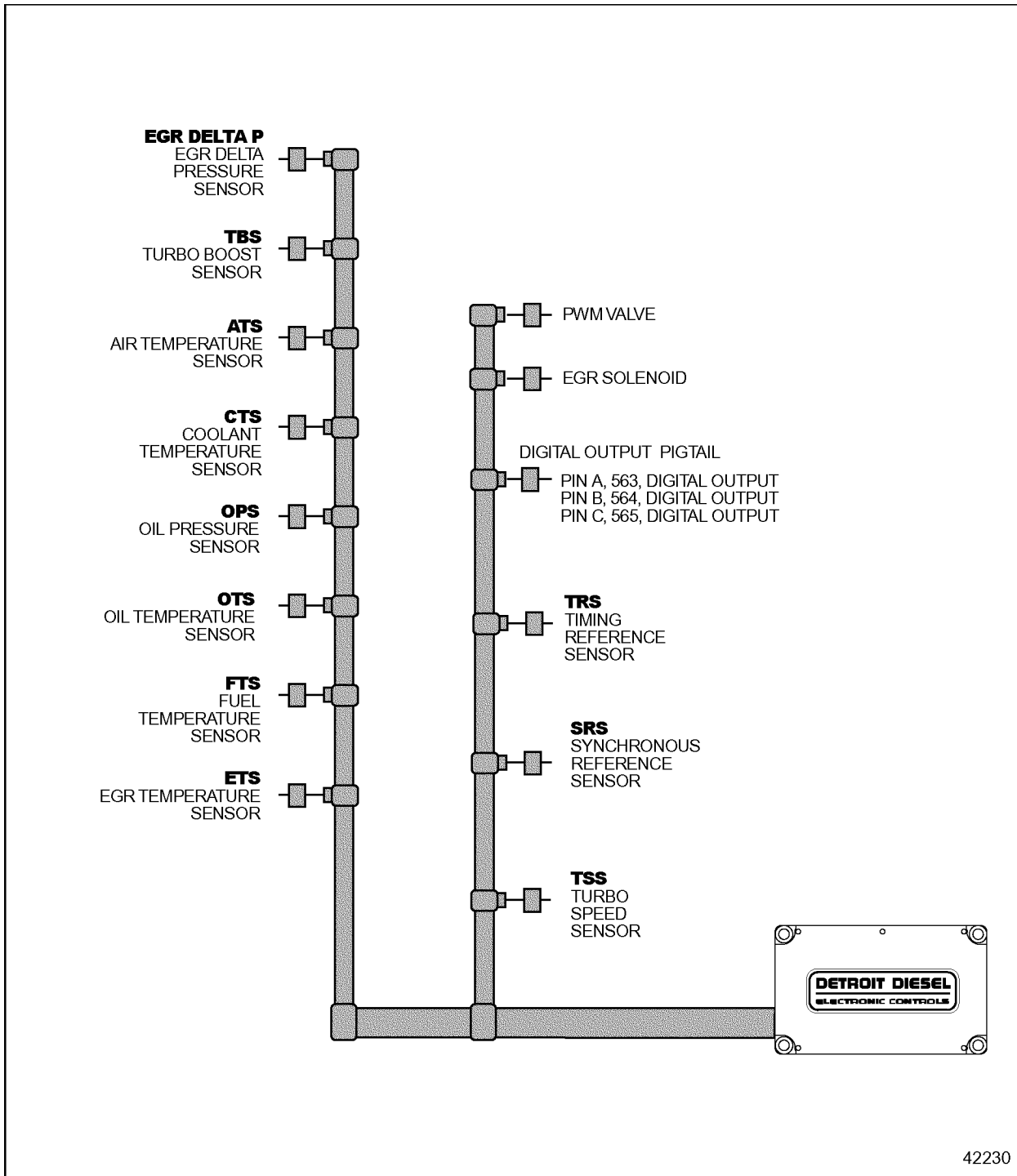

Figure 3-3 A Typical On-highway Engine Sensor Harness — Series 50

The wiring for the 30-pin ESH-to-ECM connector on a Series 60 engine is listed in Table 3-5.

Cavity	Wire No	Label	ESH-to-ECM Connector
T-1	109	TRS (-)	
T-2	110	TRS (+)	
S-2	111	SRS (+)	
S-1	112	SRS (-)	
R-2	120	OIL TEMPERATURE	
N-2	132	AIR TEMPERATURE	
P-3	133	COOLANT TEMPERATURE	
W-1	416	SENSOR SUPPLY (5VDC)	
P-1	432	TURBO BOOST	
Y-2	452	SENSOR RETURN (ENGINE)	
R-3	472	FUEL TEMPERATURE	
P-2	530	OIL PRESSURE	
S-3	561	ENGINE BRAKE MED	
T-3	562	ENGINE BRAKE LO	
W-3	563	DIGITAL OUTPUT #6	
X-3	564	DIGITAL OUTPUT #5	
Y-3	565	DIGITAL OUTPUT #4	
X-1	573	TURBO SPEED	
L-1	904	BAROMETRIC PRESSURE	
M-1	905	TURBO COMPRESSOR IN TEMPERATURE	
N-1	906	TURBO COMPRESSOR OUT TEMPERATURE	
R-1	907	EGR TEMPERATURE	
Y-1	909	EGR CONTROL	
W-2	910	OI STARTER	
X-2	911	VGT CONTROL	
L-3	925	J1939 (+)	
M-3	926	J1939 (-)	
N-3	927	J1939 SHIELD	
M-2	958	EGR DELTA PRESSURE	
L-2	976	RELATIVE HUMIDITY	

Table 3-5 Typical ESH-to-ECM Connector Pin Definitions — Series 60

The 30-pin ESH-to-ECM connector, listed in Table 3-6, is a Metri-Pack 150 series pull-to-seat connector.

Part	Part Number
Connector	12034400
Terminal	12103881
Seal	In Connector
Plug	12034413

Table 3-6 30-pin ESH-to-ECM Connector

The wiring for the 30-pin ESH-to-ECM connector on a natural gas engine is listed in Table 3-7.

Cavity	Wire No	Label	ESH-to-ECM Connector
T-1	109	TRS (-)	
T-2	110	TRS (+)	
S-2	111	SRS (+)	
S-1	112	SRS (-)	
R-2	120	EXHAUST TEMPERATURE	
N-2	132	INTAKE AIR TEMPERATURE	
P-3	133	COOLANT TEMPERATURE	
W-1	416	SENSOR SUPPLY (5VDC)	
P-1	432	INTAKE MANIFOLD PRESSURE	
Y-2	452	SENSOR RETURN (ENGINE)	
R-3	472	FUEL TEMPERATURE	
P-2	530	OIL PRESSURE	
S-3	561	THROTTLE SUPPLY	
T-3	562	FUEL SHUTOFF	
W-3	563	DIGITAL OUTPUT #6	
X-3	564	DIGITAL OUTPUT #5	
Y-3	565	DIGITAL OUTPUT #4	
X-1	573	SNEF	
L-1	904	BAROMETRIC PRESSURE	
M-1	905	FUEL PRESSURE	
N-1	906	OXYGEN SENSOR	
R-1	907	THROTTLE PLATE POSITION	
Y-1	909	THROTTLE ACTUATOR	
W-2	910	UNUSED	
X-2	911	VGT CONTROL	
L-3	925	J1939 (+)	
M-3	926	J1939 (-)	
N-3	927	J1939 SHIELD	
M-2	958	PULSE STEPPER VALVE	
L-2	976	KNOCK SENSOR	

Table 3-7 Typical ESH-to-ECM Connector Pin Definitions — Natural Gas Applications

The wiring for the 30-pin ESH-to-ECM connector on a Series 50 engine is listed in Table 3-8.

Cavity	Wire No	Label	ESH-to-ECM Connector
T-1	109	TRS (-)	
T-2	110	TRS (+)	
S-2	111	SRS (+)	
S-1	112	SRS (-)	
R-2	120	OIL TEMPERATURE	
N-2	132	AIR TEMPERATURE	
P-3	133	COOLANT TEMPERATURE	
W-1	416	SENSOR SUPPLY (5VDC)	
P-1	432	TURBO BOOST	
Y-2	452	SENSOR RETURN (ENGINE)	
R-3	472	FUEL TEMPERATURE	
P-2	530	OIL PRESSURE	
S-3	561	VGT POWER	
T-3	562	EGR SOLENOID CONTROL	
W-3	563	DIGITAL OUTPUT #6	
X-3	564	DIGITAL OUTPUT #5	
Y-3	565	DIGITAL OUTPUT #4	
X-1	573	TURBO SPEED	
L-1	904	AIR FILTER RESTRICTION (MAS ONLY)	
M-1	905	FUEL RESTRICTION (MAS ONLY)	
N-1	906	ADD COOLANT LEVEL (MAS ONLY) — 2002-2003 COMPRESSOR TEMP OUT (330 hp only) — 2004-Present	
R-1	907	EGR TEMPERATURE	
Y-1	909	PWM #2 — NOT USED	
W-2	910	PWM #3 — NOT USED	
X-2	911	PWM #3 — VGT CONTROL	
L-3	925	J1939 (+)	
M-3	926	J1939 (-)	
N-3	927	J1939 SHIELD	
M-2	958	EGR DELTA PRESSURE	
L-2	976	OIL LEVEL (MAS ONLY)	

Table 3-8 Typical ESH-to-ECM Connector Pin Definitions — Series 50

THIS PAGE INTENTIONALLY LEFT BLANK

3.4 VEHICLE INTERFACE HARNESS

The OEM supplied Vehicle Interface Harness (VIH) connects the ECM to other vehicle systems as shown in the VIH illustrations. See Figure 3-4. Refer to Appendix B for a harness schematic.

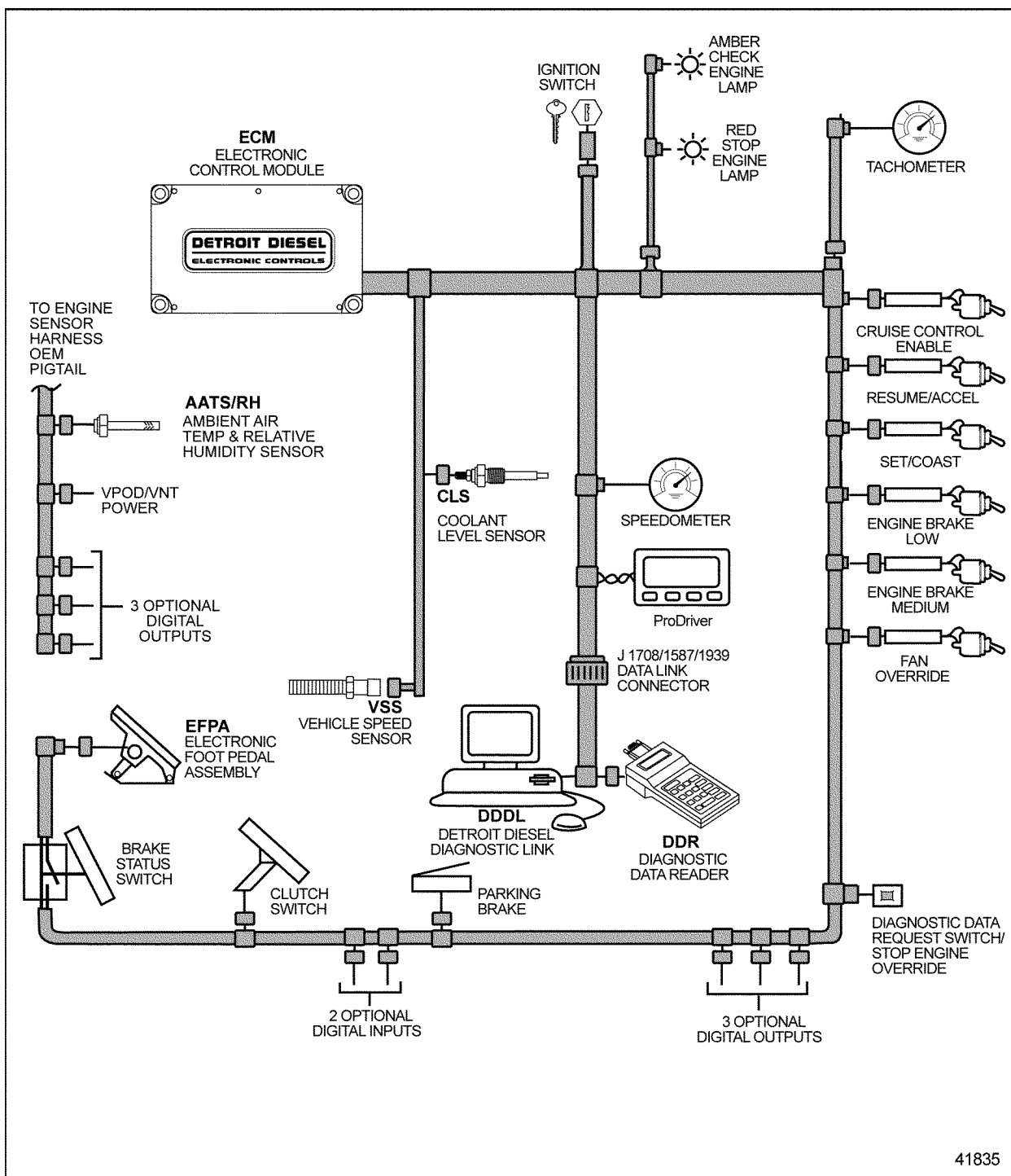

Figure 3-4 Typical On-highway Vehicle Interface Harness

The wiring for the 30-pin VIH-to-ECM connector is listed in Table 3-9.

Cavity	Wire No.	Label	VIH-to-ECM Connector
H-3	115	COOLANT LEVEL	
D-2	417	LIMITING SPEED GOVERNOR	
B-1	419	CHECK ENGINE LIGHT	
B-3	439	IGNITION	
E-1	451	DIGITAL INPUT #1	
F-3	499	DIGITAL OUTPUT #1	
K-1	505	TACHOMETER DRIVE	
B-2	509	STOP ENGINE LIGHT	
D-1	510	OI THERMOSTAT OR PTO OR EXHAUST BACK PRESSURE SENSOR (COACH ONLY)	
H-1	523	DIGITAL INPUT #7	
H-2	524	DIGITAL INPUT #8	
G-1	528	DIGITAL INPUT #4	
J-2	531	DIGITAL INPUT #10	
J-1	541	DIGITAL INPUT #9	
F-1	542	DIGITAL INPUT #2	
G-2	543	DIGITAL INPUT #5	
F-2	544	DIGITAL INPUT #3	
G-3	545	DIGITAL INPUT #6	
A-2	555	DIGITAL OUTPUT #2	
E-2	556	VEHICLE SPEED (+)	
E-3	557	VEHICLE SPEED (-)	
K-2	583	DIGITAL INPUT #11	
D-3	749	ESS OR FIRE TRUCK PUMP PRESSURE	
C-2	900	J1587 DATA LINK (+)	
C-1	901	J1587 DATA LINK (-)	
J-3	908	VARIABLE SPEED FAN OR PWM TRANSMISSION OR OI ALARM	
A-3	916	SENSOR SUPPLY (5VDC)	
C-3	952	SENSOR RETURN	
K-3	979	DIGITAL INPUT #12	
A-1	988	DIGITAL OUTPUT #3	

Table 3-9 Typical VIH-to-ECM Connector Pin Definitions — Truck/Coach Applications

The 30-pin VIH-to-ECM connector, listed in Table 3-10, is a Metri-Pack 150 series pull-to-seat connector.

Part	Part Number
Connector	12034398
Terminal	12103881
Plug	12034413

Table 3-10 30-pin VIH-to-ECM Connector

The ECM connector assembly center screw must be torqued to 22–28 in·lb. (2.49–3.16 N·m).

The 30-pin VIH-to-ECM connector wiring for urban bus applications is listed in Table 3-11.

Cavity	Wire No.	Label	VIH-to-ECM Connector
H-3	115	COOLANT LEVEL	<p style="text-align: center;">37018</p>
D-2	417	LIMITING SPEED GOVERNOR	
B-1	419	CHECK ENGINE LIGHT	
B-3	439	IGNITION	
E-1	451	DIGITAL INPUT #1	
F-3	499	DIGITAL OUTPUT #1	
K-1	505	TACHOMETER DRIVE	
B-2	509	STOP ENGINE LIGHT	
D-1	510	PTO OR EXHAUST BACKPRESSURE (OPTIONAL)	
H-1	523	DIGITAL INPUT #7	
H-2	524	DIGITAL INPUT #8	
G-1	528	DIGITAL INPUT #4	
J-2	531	DIGITAL INPUT #10	
J-1	541	DIGITAL INPUT #9	
F-1	542	DIGITAL INPUT #2	
G-2	543	DIGITAL INPUT #5	
F-2	544	DIGITAL INPUT #3	
G-3	545	DIGITAL INPUT #6	
A-2	555	DIGITAL OUTPUT #2	
E-2	556	VEHICLE SPEED (+)	
E-3	557	VEHICLE SPEED (-)	
K-2	583	DIGITAL INPUT #11	
D-3	749	EXHAUST TEMPERATURE	
C-2	900	J1587 DATA LINK (+)	
C-1	901	J1587 DATA LINK (-)	
J-3	908	PWM #1 — VARIABLE SPEED FAN OR PWM TRANSMISSION	
A-3	916	SENSOR SUPPLY (5VDC)	
C-3	952	SENSOR RETURN	
K-3	979	DIGITAL INPUT #12	
A-1	988	DIGITAL OUTPUT #3	

Table 3-11 Typical VIH-to-ECM Connector Pin Definitions — Urban Bus Applications

The wiring for the 30-pin VIH-to-ECM connector for natural gas applications is listed in Table 3-12.

Cavity	Wire No.	Label	VIH-to-ECM Connector
H-3	115	COOLANT LEVEL	<p style="text-align: center;">37018</p>
D-2	417	LIMITING SPEED GOVERNOR	
B-1	419	CHECK ENGINE LIGHT	
B-3	439	IGNITION	
E-1	451	DIGITAL INPUT #1	
F-3	499	DIGITAL OUTPUT #1	
K-1	505	TACHOMETER DRIVE	
B-2	509	STOP ENGINE LIGHT	
D-1	510	RELATIVE HUMIDITY	
H-1	523	DIGITAL INPUT #7	
H-2	524	DIGITAL INPUT #8	
G-1	528	DIGITAL INPUT #4	
J-2	531	DIGITAL INPUT #10	
J-1	541	DIGITAL INPUT #9	
F-1	542	DIGITAL INPUT #2	
G-2	543	DIGITAL INPUT #5	
F-2	544	DIGITAL INPUT #3	
G-3	545	DIGITAL INPUT #6	
A-2	555	DIGITAL OUTPUT #2	
E-2	556	VEHICLE SPEED (+)	
E-3	557	VEHICLE SPEED (-)	
K-2	583	PSV DIAGNOSTIC	
D-3	749	AMBIENT AIR TEMPERATURE	
C-2	900	J1587 DATA LINK (+)	
C-1	901	J1587 DATA LINK (-)	
J-3	908	VARIABLE SPEED FAN OR PWM TRANSMISSION	
A-3	916	SENSOR SUPPLY (5VDC)	
C-3	952	SENSOR RETURN	
K-3	979	DIGITAL INPUT #12	
A-1	988	DIGITAL OUTPUT #3	

Table 3-12 Typical VIH-to-ECM Connector Pin Definitions — Natural Gas Applications

3.4.1 VIH DESIGN

The following criteria are to be used when designing the VIH.



Criteria: VIH Design

The VIH 30-pin connector is designed to accept 18 gage (0.75 - 0.80 mm²) standard wall thickness cable only.

The acceptable cable insulations are Teflon (EFTE), cross-link polyethylene (XLPE) or any equivalent self-extinguishing insulation such as GXL having a minimum rating of -40°C to 125°C. An equivalent insulation must meet the acceptable cable diameters from 2.00 - 2.42 mm.

The conductor must be annealed copper, not aluminum, and must comply with the industry standard SAE J1128 document.

Detroit Diesel Corporation recommends color coding and hot stamping wire numbers in contrasting colors at intervals of four inches or less.

NOTE:

Avoid renumbering DDC circuits since all troubleshooting guides reference the circuit numbers shown in the schematic. DDC suggests including a prefix or suffix with the DDC circuit numbers when conflicts exist.

NOTE:

The Vehicle Speed Sensor (VSS) circuits 556 and 557 and the Data Link circuits 900 and 901 (SAE J1587) must be twisted pairs. The twists are a minimum of 12 turns per foot (305 mm) and are required to minimize electromagnetic field coupling.

NOTE:

The maximum length for the SAE J1708/J1587 Data Link is 40 m (130 ft). The maximum length for the SAE J1939 Data Link is 40 m (130 ft).

3.4.2 VIH INSTALLATION

The following concepts have proven to be effective in installing the VIH.

Provide maximum physical separation of the VIH from other vehicle electrical systems. Other electrical system cables should ideally be at least three feet away from the VIH and should not be parallel to the VIH. This will eliminate coupling electromagnetic energy from other systems into the VIH.

Do not route the harness near any vehicle moving parts, exhaust or any high heat source.

Use a protective sheath to prevent wires from being cut or frayed when weaving harness through the frame.

The 30-pin VIH-to-ECM connector assembly (12034398) center screw must be torqued to 22–28 in·lb. (2.49–3.16 N·m).

Adhere to industry standards for relief length and maximum wire bend radius at the connectors.

3.4.3 HARNESS DESIGN GUIDELINES

The electrical characteristics of some of the system elements including the ECM are described in the following sections. This information is useful for harness design.

NOTE:

All output loads (PWM and digital outputs), ignition, and ECM power must be powered by the same battery voltage.

Pulse Width Modulated Port (PWM #1, 2, 4)

The output of this port is capable of providing 50 to 1000 Hz modulation between 0% and 100% duty cycle with a resolution of less than or equal to 0.1% duty cycle and an accuracy of less than or equal to 20 μ sec.

Output Characteristics:

Output On: E_{out} is less than or equal to 0.8 volts with respect to ECM ground.
 I_{sink} is less than or equal to 5 mA.
 Output Off: $I_{leakage}$ (I_{sink}) is less than or equal to 1.0 mA while $0 \leq E_{out} \leq V_{battery}$.

Load Drive Capabilities:

Inductance: Capable of connecting to an inductance less than or equal to 60 mH at 100 Hz.
 I_{sink} : Capable of sinking an average current of 3 A or less and peak current of 6 A or less.

PWM #2 (909) is used for EGR control – Series 60 only.

PWM #3 (910) is used for Optimized Idle starter only.

PWM #4 (911) is used for VGT control – Series 50 and Series 60.

Digital Output Ports

The digital output ports are: 419, 509, 988, 555, 499, 563, 564, and 565. Wire numbers 419 and 509 are reserved for the CEL and SEL, respectively. Refer to section 4.3, "Digital Outputs" for additional information.

Output Characteristics:

Output On: E_{out} is less than or equal to 0.8 volts with respect to ECM ground (#150).
 I_{sink} is less than or equal to 1.5 A.
 Output Off: $I_{leakage}$ (I_{sink}) is less than or equal to 1.0 mA while $0 \leq E_{out} \leq V_{battery}$.

Load Drive Capabilities:

Inductance: Capable of connecting to an inductance less than or equal to 85 mH. If load is >85 mH then external clamping is required.
 I_{sink} : Capable of sinking less than or equal to 1.5 A.

The digital output ports are capable of driving a #168 bulb (three candlepower lamp) in a 12 volt system or a # 313 bulb (three candlepower lamp) in a 24 volt system. See Figure 3-5.

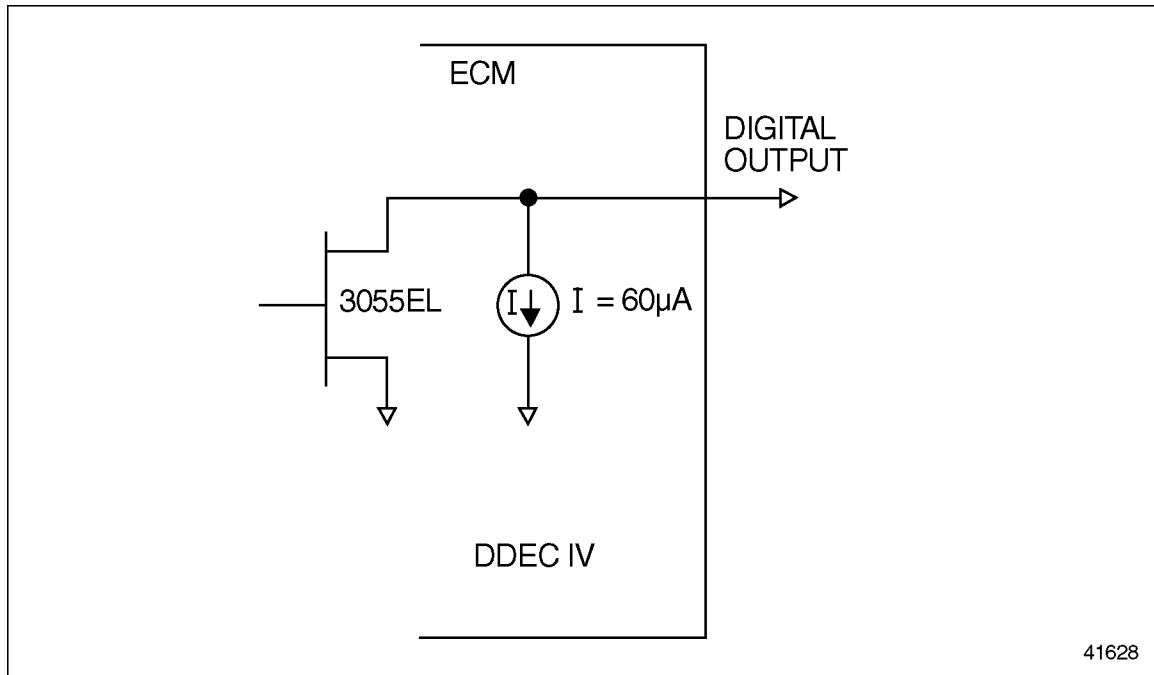

Figure 3-5 DDEC IV Internal Digital Output Circuits

Digital Input Ports

The digital input ports are: 451, 542, 528, 523, 541, 544, 543, 524, 531, 583, 545 and 979. Refer to section 4.3, "Digital Inputs" for additional information.

Input Requirements:

- High State: $32 \text{ volts} > E_{in} > 4 \text{ volts}$ at less than 0.2 mA leakage current.
The ECM has an internal $1\text{k}\Omega$ pull-up to 5 volts.
- Low State: $E_{in} < 1.0 \text{ volts}$.
- I_{source} : Capable of sourcing up to 5 mA.

NOTE:

Use switches that will not oxidize with the passage of time and environmental factors due to the low source current.

A DDEC IV digital input circuit may be seen in the next illustration (see Figure 3-6).

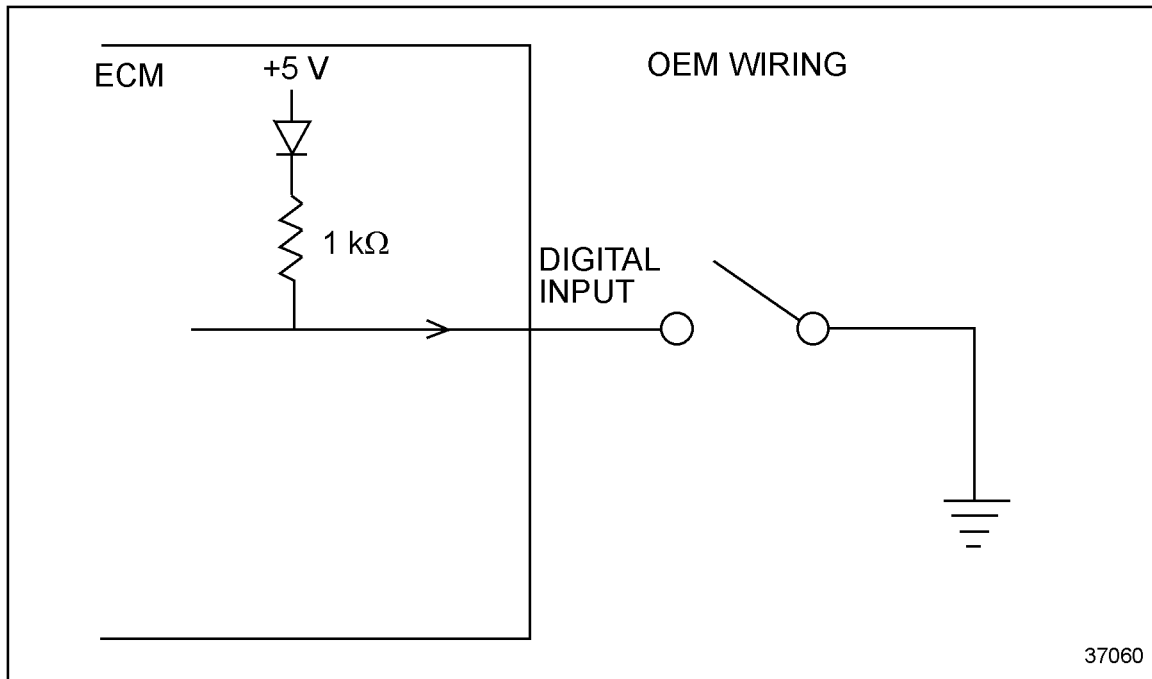

Figure 3-6 DDEC IV Digital Input Circuit

Switch Ground

Switch ground (circuit 953) must only be used to provide ground for DDEC components (i.e. digital inputs) and must be sourced directly from the negative battery or bus bar terminal; refer to section 3.7, "Power Harness."

NOTE:

This circuit can not be used to provide ground for non-DDEC OEM-supplied electronics.

Ignition

The ignition source may be either 12 or 24 volts depending on the ECM configuration. The DDEC ignition must be an independent input sourced directly from the battery post via a weatherproof blade type fuse, circuit breaker, or equivalent. Fuse holders for blade type fuses may be purchased from the DDC Parts Distribution Center. Part numbers are listed in Table 3-13.

Part	Part Number
Fuse Holder	12033769
Cover	12033731
Terminals	12066614

Table 3-13 Fuse Holder Part Numbers

Ignition voltage must be continuously provided in the crank and run modes. The ignition fuse must be sized for the loads utilized in each application.

3.4.4 OEM INTERFACE TO ENGINE SENSOR HARNESS

The connector that is the OEM interface to the Engine Sensor Harness (ESH) is different for the Series 60 and Series 50 engines.

Series 60

A ten-pin connector will be used for the OEM connection to the ESH (see Figure 3-7).

This connector contains the following functions:

- VPOD Power and Ground
- Relative Humidity/Turbo Compressor Inlet Temperature Sensor
- Three Optional Digital Outputs
- Optimized Idle Starter

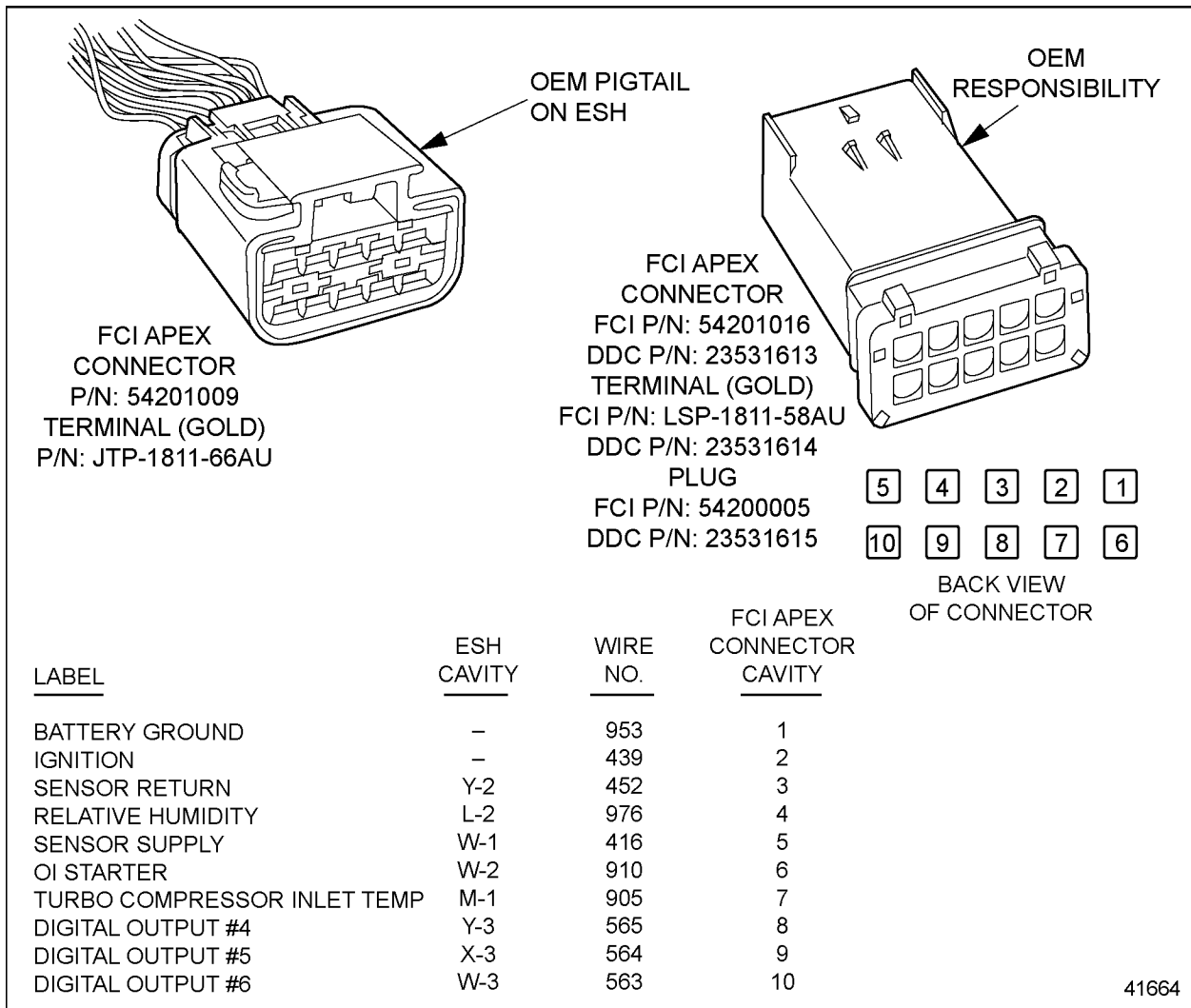

Figure 3-7 OEM Connection to the Engine Sensor Harness – Series 60

FCI Apex connectors are available from:

NTI, LLC

300 Randall Street, Suit B

Greer, SC 29651

Telephone: 864-877-4800

Fax: 864-877-2997

FCI Automotive

Telephone: 1-800-303-3577

734-728-2100

For more information on the installation of the Relative Humidity/Turbocharger Compressor Inlet Temperature Sensor, refer to section 3.14.23.

Series 50

For Series 50 applications, the OEM will have a 3-pin Metri-Pack connector for use with optional digital outputs and an optional 8-pin connector for the Maintenance Alert System. Refer to the VIH diagram in Appendix B.

Natural Gas Applications

Refer to section 3.4.6 for the natural gas application requirements for interfacing to the Engine Sensor Harness.

3.4.5 VARIABLE PRESSURE OUTPUT DEVICE — SERIES 60 ONLY

There are two Variable Pressure Output Devices (VPOD) that control the Variable Geometry Turbo (VGT) and the Exhaust Gas Recirculation (EGR) system (see Figure 3-8). The location of the VPODs is application dependent.

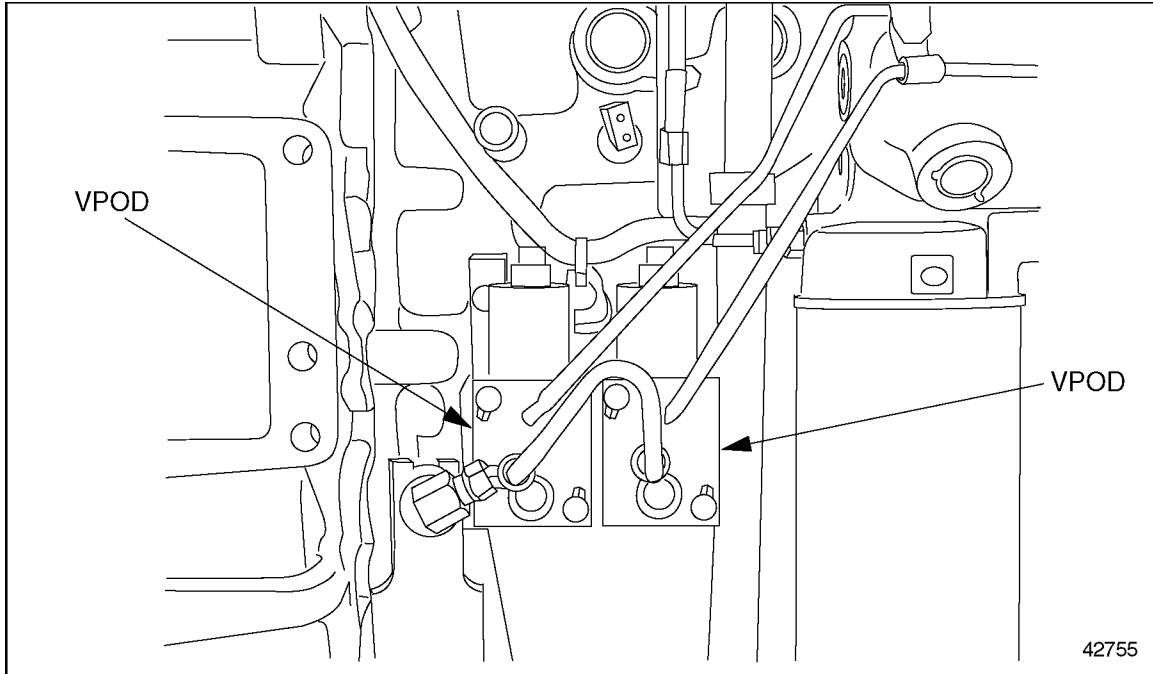

Figure 3-8 VPOD Location — Series 60 Only

The OEM is responsible for supplying power to the VPODs via the 10-pin OEM interface connector (refer to section 3.4.4). The power can be sourced from the ignition switch. The fuse must be properly sized. The operating characteristics of one VPOD are listed in Table 3-14. There are two VPODs in the system.

Description	12V	24V
Minimum Operating Voltage	8V	16V
Maximum Current Draw (ignition on, engine not running)	20mA	30mA
Maximum Operating Average Current	1.0A	0.5A
Maximum Operating Peak Current	3.0A	2.0A
In Rush Current	20.0A	10.0A

Table 3-14 VPOD Operating Characteristics

3.4.6 NATURAL GAS APPLICATIONS — VIH REQUIREMENTS

The following information is required for natural gas engine installations.

Dedicated Power & Ground Requirements

The wires listed in Table 3-15 require dedicated power and grounds. They can be found on the wiring diagram (refer to Appendix B).

Wire Number	Description
956	Throttle Ground
443	SNEF Power (Ignition Switched)
150	PSV Ground
446	PSV Power (Ignition Switched)
957	Oxygen Sensor Interface Module Ground
444	Oxygen Sensor Interface Power (Ignition Switched)
445	Throttle Power (Ignition Switched and DDEC Switched)

Table 3-15 Wires Requiring Dedicated Power and Ground

Correct grounding of the DDEC components is critical to proper engine operation. Poor grounds can cause ignition system misfire, RFI/EMI, and false DDEC codes. Grounding problems can be minimized by adhering to the following guidelines:

- The engine block must be properly grounded.
- Ground wires #150, 956, 957, and 959 from the OEM Sensor Ground Harness (see Figure 3-12) ground wire #953 from the Coil Power Harness (see see Figure 3-13) and the three DDEC ECM main power ground wires #150 (see Figure 3-9) must go to a common negative battery terminal. Use an individual 12 AWG wire (do not exceed 28 ft in length) for each of the seven ground wires to the battery. If a ground stud or bar is used before going to the battery, do not source any other grounds from that ground stud or bar. Use an individual 12 AWG wire (do not exceed 28 ft in length) for each of the seven ground wires to the ground stud or bar. A 2/0 AWG or larger cable must be used to connect the ground stud or bar directly to a negative battery terminal. Do not source any other grounds from this cable.
- Do not install relays in any of the DDEC ground circuits unless it is required by DDC.

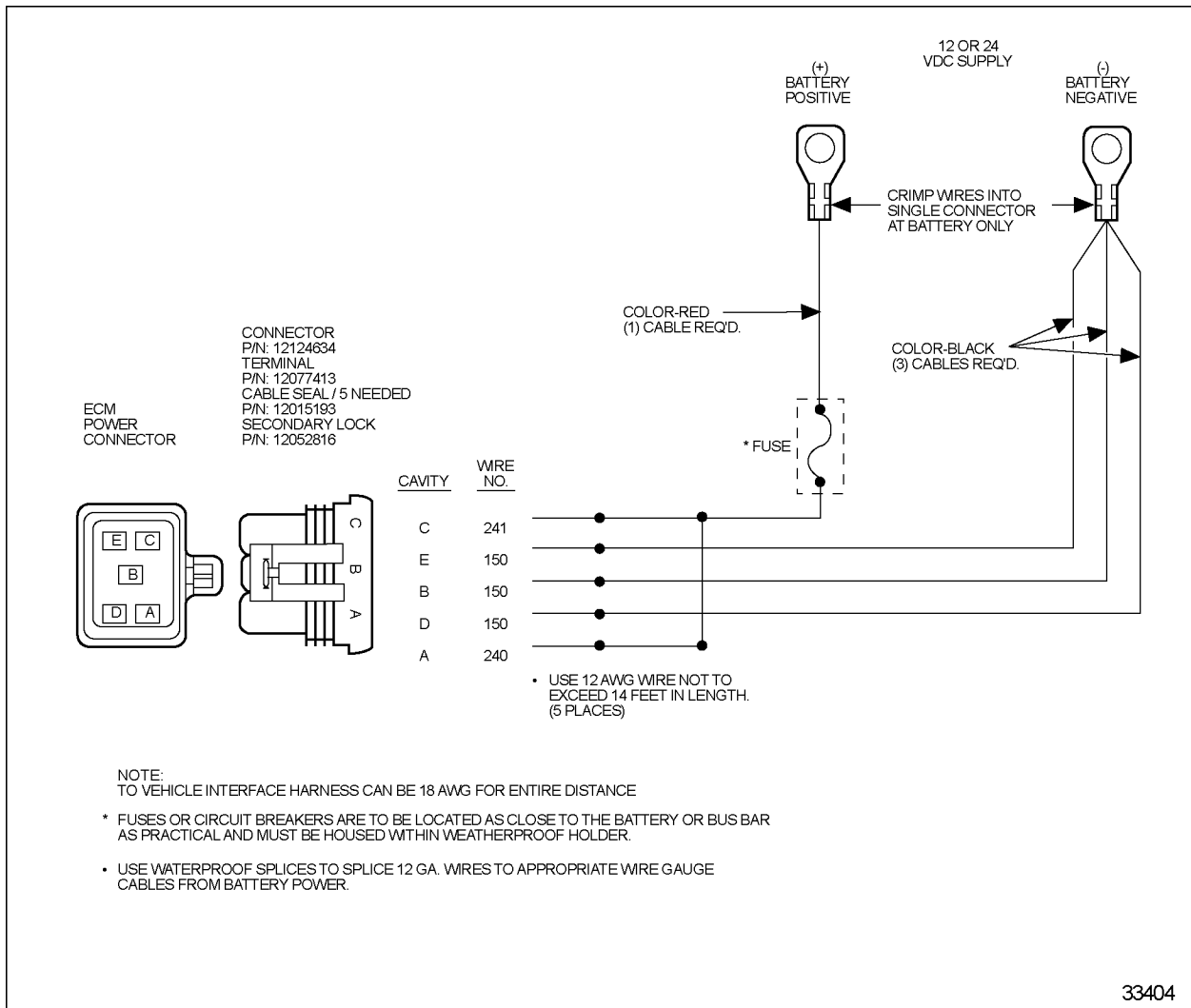

Figure 3-9 Power Wiring

The following guidelines should be followed in designing the DDEC power circuits:

- Do not install relays in any of the DDEC power or control circuits other than those required by DDC.
- Do not install more than one fuse per circuit.

Relay Powered Throttle

Throttle power actuation will be done through an OEM supplied relay using either 12 or 24 volts. S3 wire 561 (High Side Digital Output) will provide ECM power (12 V or 24 V) to trigger the relay. A dedicated 12 or 24 volt power source will travel through the relay to wire 445 to the throttle. Wire 561 and 445 are shown on the main wiring diagram layout and their individual connector diagram layouts (see Figure 3-10).

The relay must have a response time of <100 ms to avoid false throttle codes. also the resistance across the trigger side of the relay must be within 1 k–2 k Ω to avoid false driver codes. A supplemental resistor can be used if necessary.

Relay Powered Fuel Shutoff Valves

Electronically controlled fuel shutoff solenoid valves are required on the high pressure side of the fuel system (typically at the fuel tanks) and the low pressure side of the fuel system near the engine. The OEM is responsible for the high pressure shutoff valves. The low pressure shutoff valve must be purchased from DDC (12 V or 24 V valves are available). All electronic fuel shutoff solenoid valves must be DDEC controlled.

The relay must have a response time of <100 ms to avoid false throttle codes. also the resistance across the trigger side of the relay must be within 1 k–2 k Ω to avoid false driver codes. A supplemental resistor can be used if necessary.

DDEC control of the fuel shutoff solenoid valves will be done through an OEM supplied relay using either 12 V or 24 V. Digital output T3 wire 562 (High Side Digital Output) will provide ECM power, either 12 V or 24 V, to trigger the relay. A dedicated 12 V or 24 V power source will travel from the relay to the solenoid valves (see Figure 3-11). The tank side solenoids and the engine side solenoid must be controlled in this manner. Separate relays can be used for the tank side solenoids and the engine side solenoid, as long as they are triggered by T3 wire 562.

OEM Sensor Power Harness

This harness provides 12 VDC power to the SNEF module, PSV, throttle, VPODs, and ECM through a 6-pin connector (see Figure 3-10).

NOTICE:

The SNEF module power supply must be 12 VDC only to ensure proper operation.

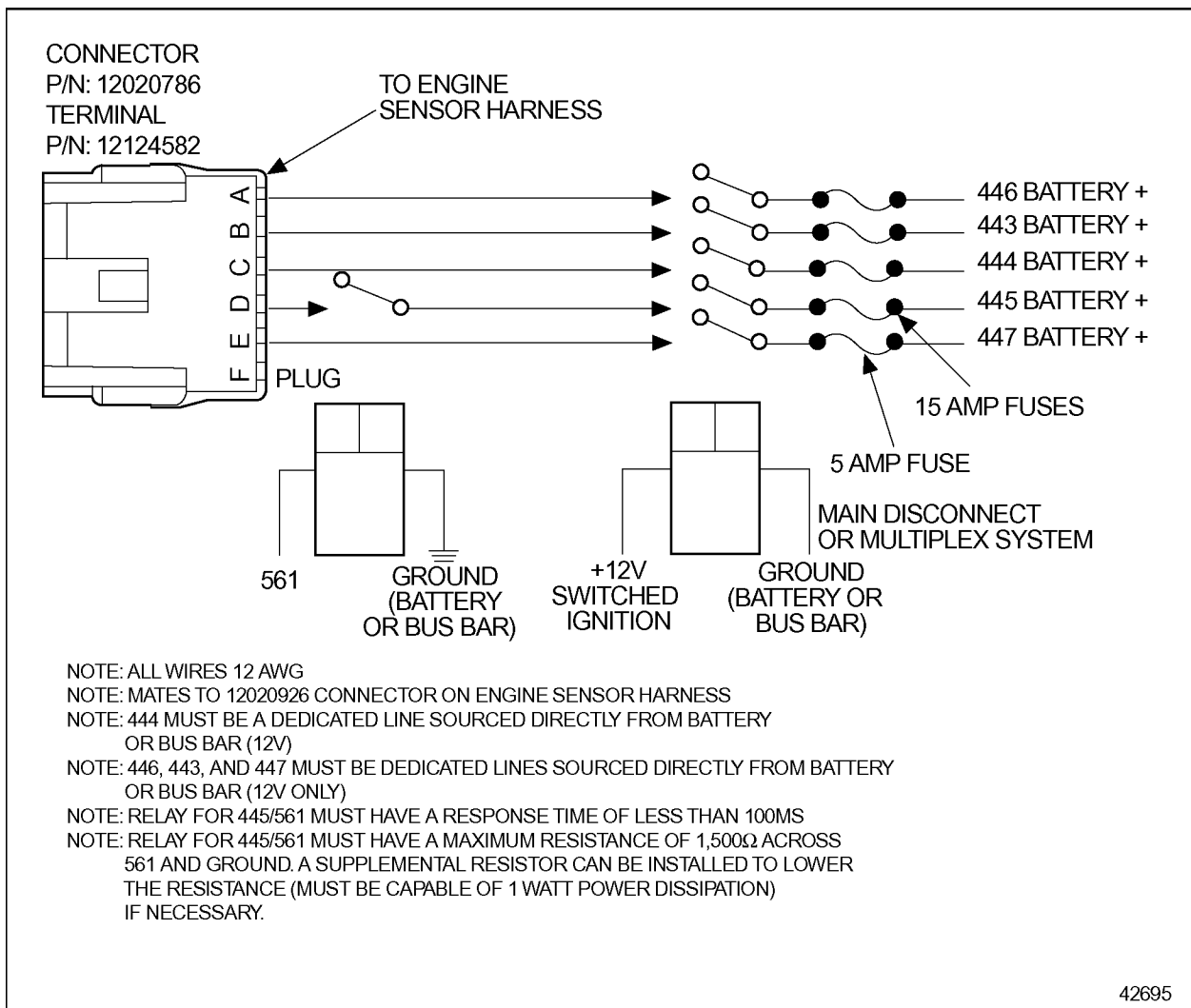

Figure 3-10 OEM Sensor Power Harness

Fuel Shutoff Harness

This harness connects to the engine side fuel shutoff solenoid and provides power to the fuel shutoff valve (DDEC switch, 12/24 V). See Figure 3-11.

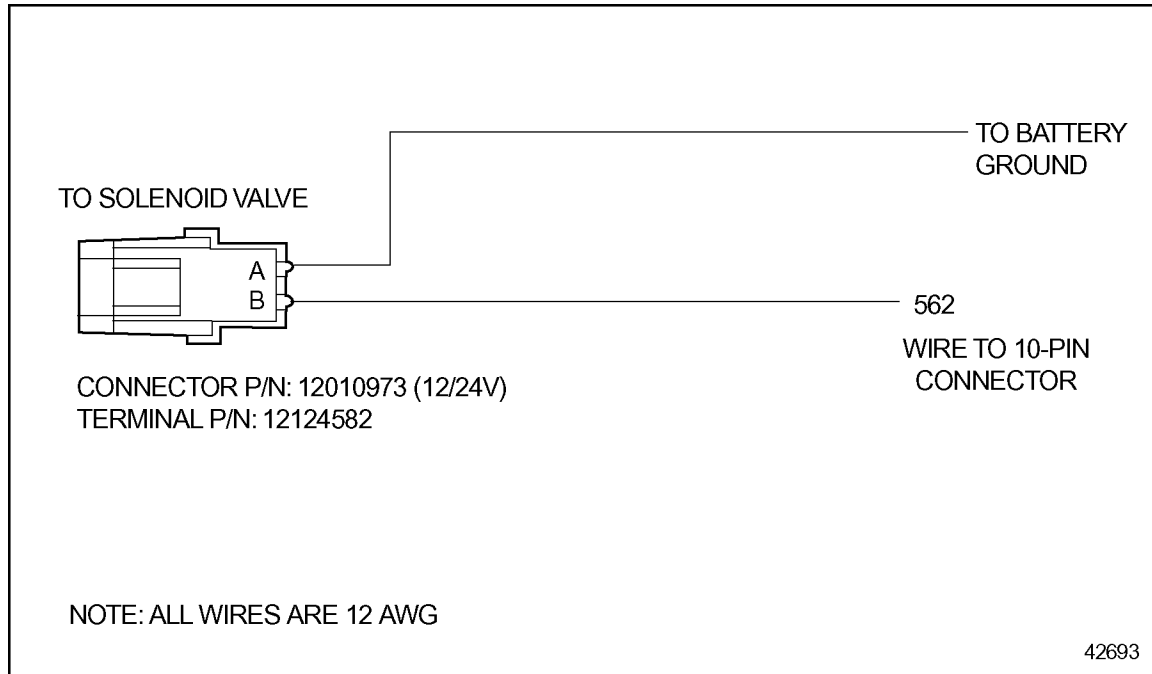

Figure 3-11 Fuel Shutoff Harness

OEM Sensor Ground Harness

Provides ground to the PSV, throttle and Oxygen Sensor Interface Module. This harness connects to a pigtail on the Engine Sensor Harness. See Figure 3-12.

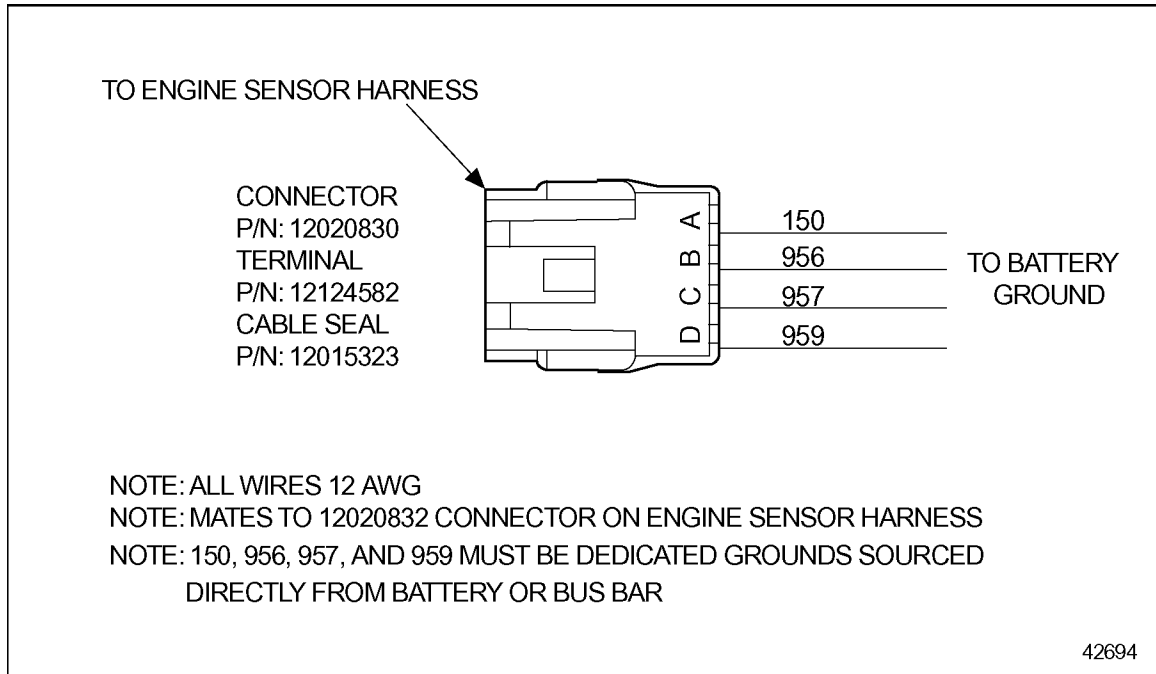

Figure 3-12 OEM Sensor Ground Harness

Coil Power Harness

This harness provides power to the engine ignition coils (see Figure 3-13).

NOTICE:

The ignition coil power supply must be 12 VDC only to ensure proper operation.

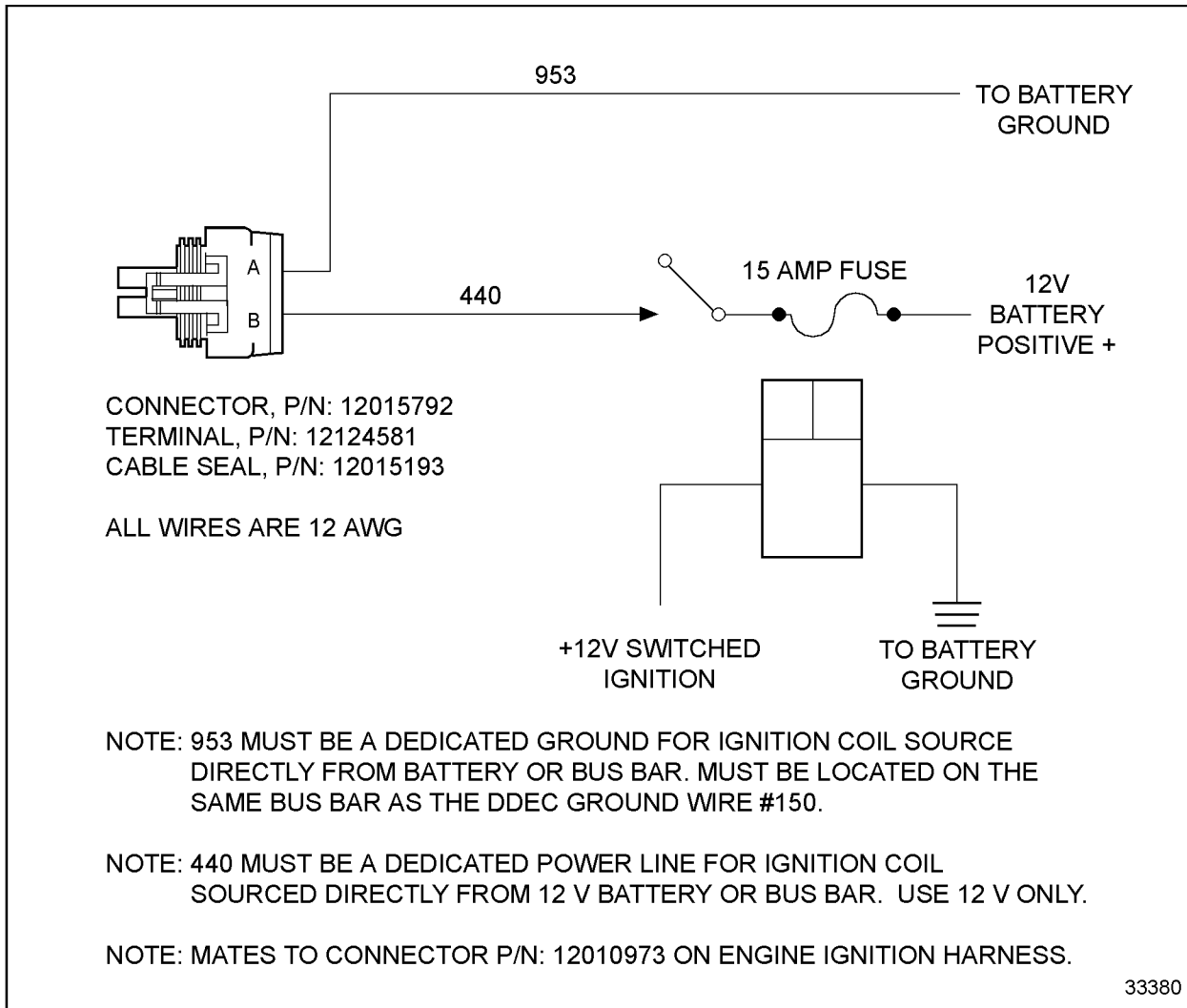

Figure 3-13 **Coil Power Harness**

OEM Interface Connector for Natural Gas Applications

A ten-pin connector will be used for the OEM connection the Engine Sensor Harness (see Figure 3-14).

This connector contains the following functions:

- Throttle Supply Circuit
- Fuel Shutoff Circuit
- Three Optional Digital Outputs
- PSV Diagnostics

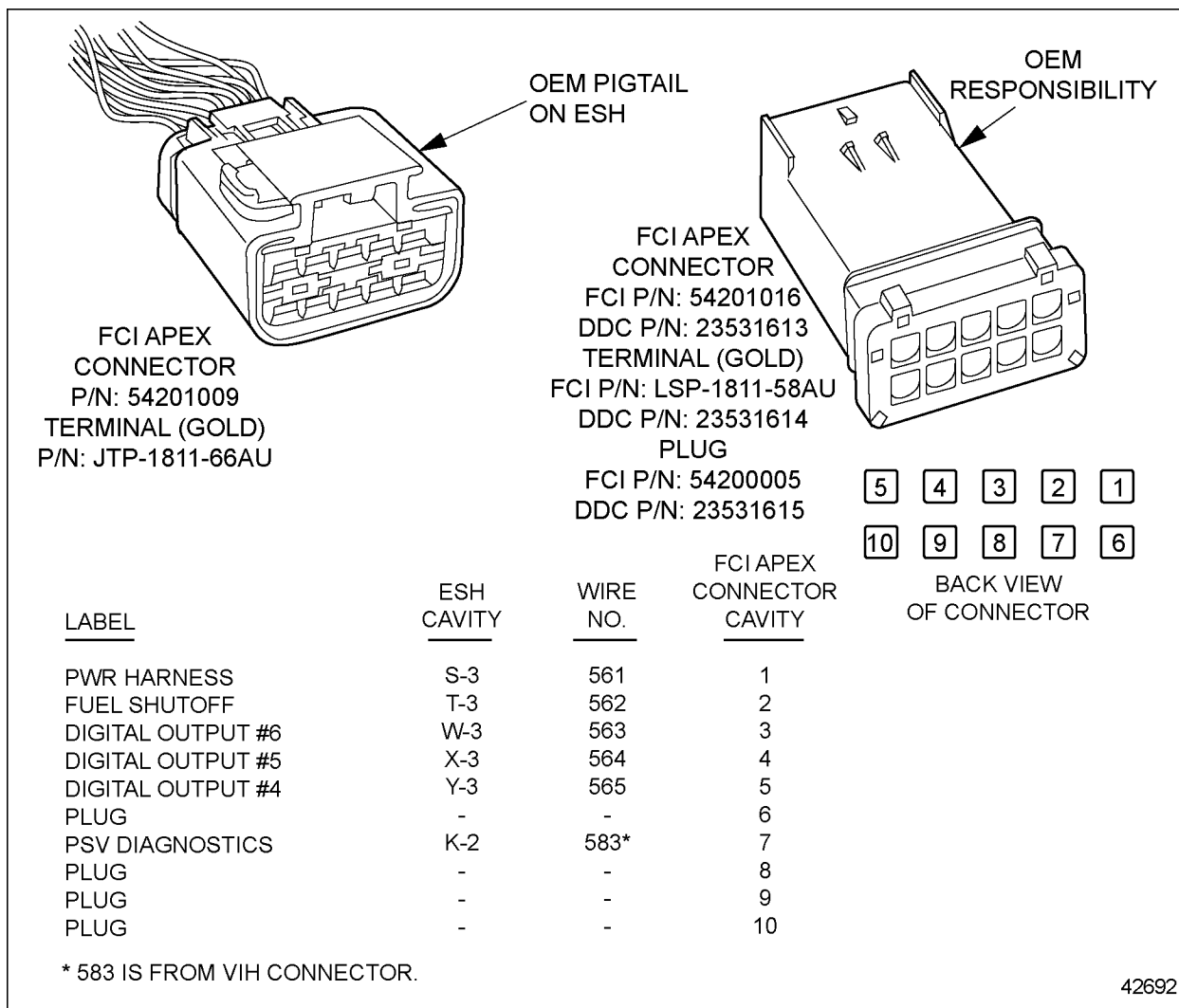

Figure 3-14 OEM Connection to the Engine Sensor Harness — Natural Gas Applications

THIS PAGE INTENTIONALLY LEFT BLANK

3.5 COMMUNICATION HARNESS

The OEM-supplied Communication Harness connects the ECM ports for SAE J1922 and SAE J1939 to other vehicle systems such as traction control devices, transmissions, braking systems, and retarders as shown in the communication harness schematic; see Figure 3-15.

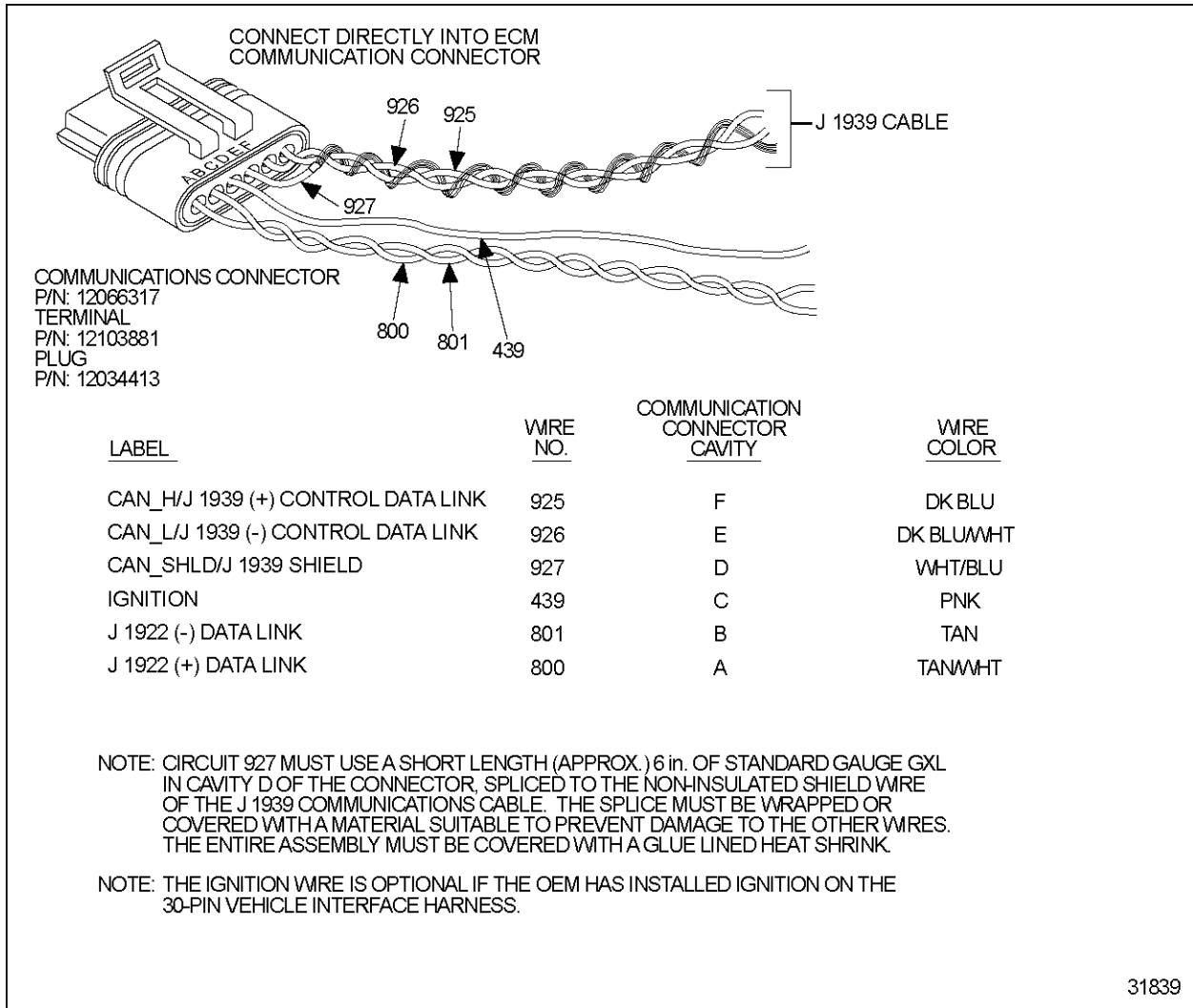

Figure 3-15 Communication Harness

Both SAE J1922 and SAE J1939 provide for the interchange of interactive control data between vehicle systems and eliminate the need for redundant sensors. SAE J1922 runs at 9.6K baud while SAE J1939 runs at 250K baud.

3.5.1 DESIGN GUIDELINES

The design guidelines for the Communication Harness are as follows:

- SAE J1922:** The SAE J1922 wire pairs (800 & 801) must be twisted a minimum of 12 turns per foot (305 mm). Twisting this wire pair will minimize the electromagnetic coupling effects.
- SAE J1939:** The SAE J1939 wiring must follow the SAE J1939 wiring guidelines including termination resistors. Refer to SAE J1939-11 for further details on cable specification.

J1939 cable is available from the following vendors:

Belden Electronics Division

2200 U.S. 27 South
Richmond, IN 47374
Phone: 1-800-235-3361
www.belden.com

Tyco Electronics Corporation

Raychem Wire and Harnessing
300 Constitution Drive
Menlo Park, CA 94025
Phone: 1-800-926-2425
www.raychem.com

The following list of SAE documents covers SAE J1939:

- J1939 - Top Layer (Overview)
- J1939/11 Physical Layer
- J1939/21 Data Link Layer
- J1939/71 Vehicle Application Layer
- J1939/01 Recommended Practice for Control and Communications Network for On-highway Equipment
- J1939/73 Application Layer Diagnostics

To obtain a copy of the SAE documents for SAE J1922 and SAE J1939, contact the Society of Automotive Engineers (SAE).

SAE International

400 Commonwealth Drive
Warrendale, PA 15096
Attention: Publications
Phone: (412) 776-4970
www.sae.org

For a list of messages supported by DDEC, refer to Chapter 5, "Communication Protocols."

3.6 INJECTOR HARNESS

The injector harness (see Figure 3-16) is installed at the factory and are delivered completely connected to the injection units and the ECMs.

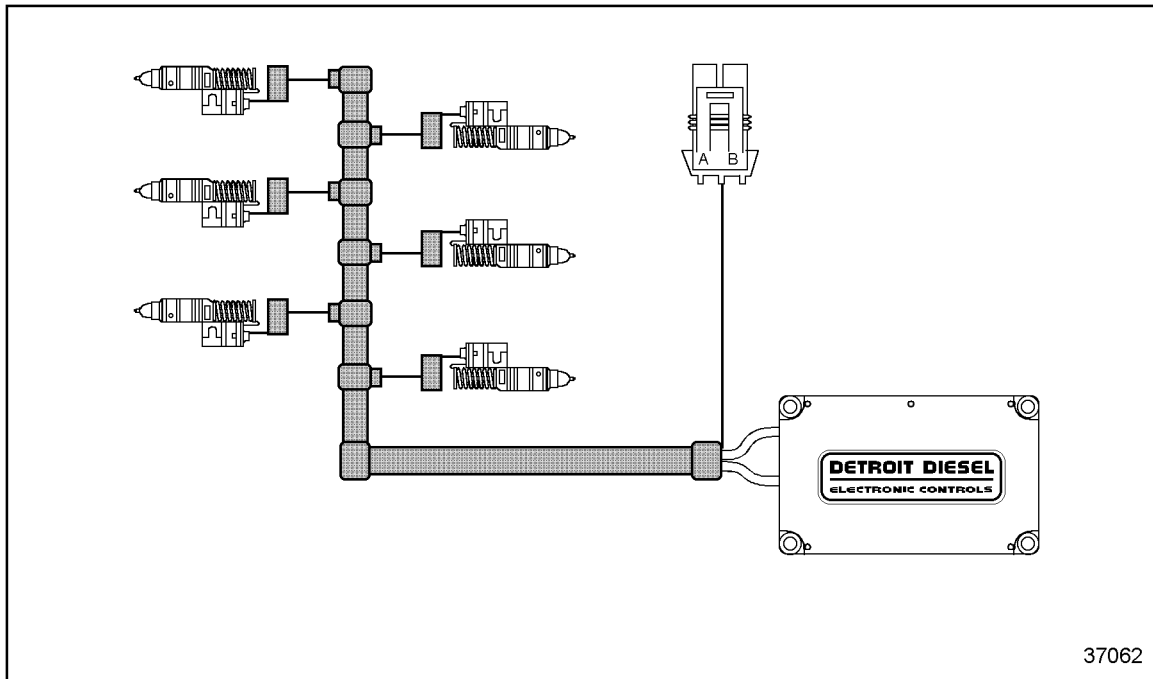

Figure 3-16 Typical On-highway Injector Harness

Injector harness schematic may be found in the Appendix (refer to Appendix B).

3.6.1 ELECTRONIC UNIT INJECTOR

The Electronic Unit Injector (EUI) uses a solenoid operated valve to control injection timing and metering. The source for high pressure fuel delivery is the cam/rocker arm system. Fuel injection begins when the solenoid valve is closed. Opening the solenoid valve ends injection. The duration of valve closure determines the quantity of fuel injected. See Figure 3-17.

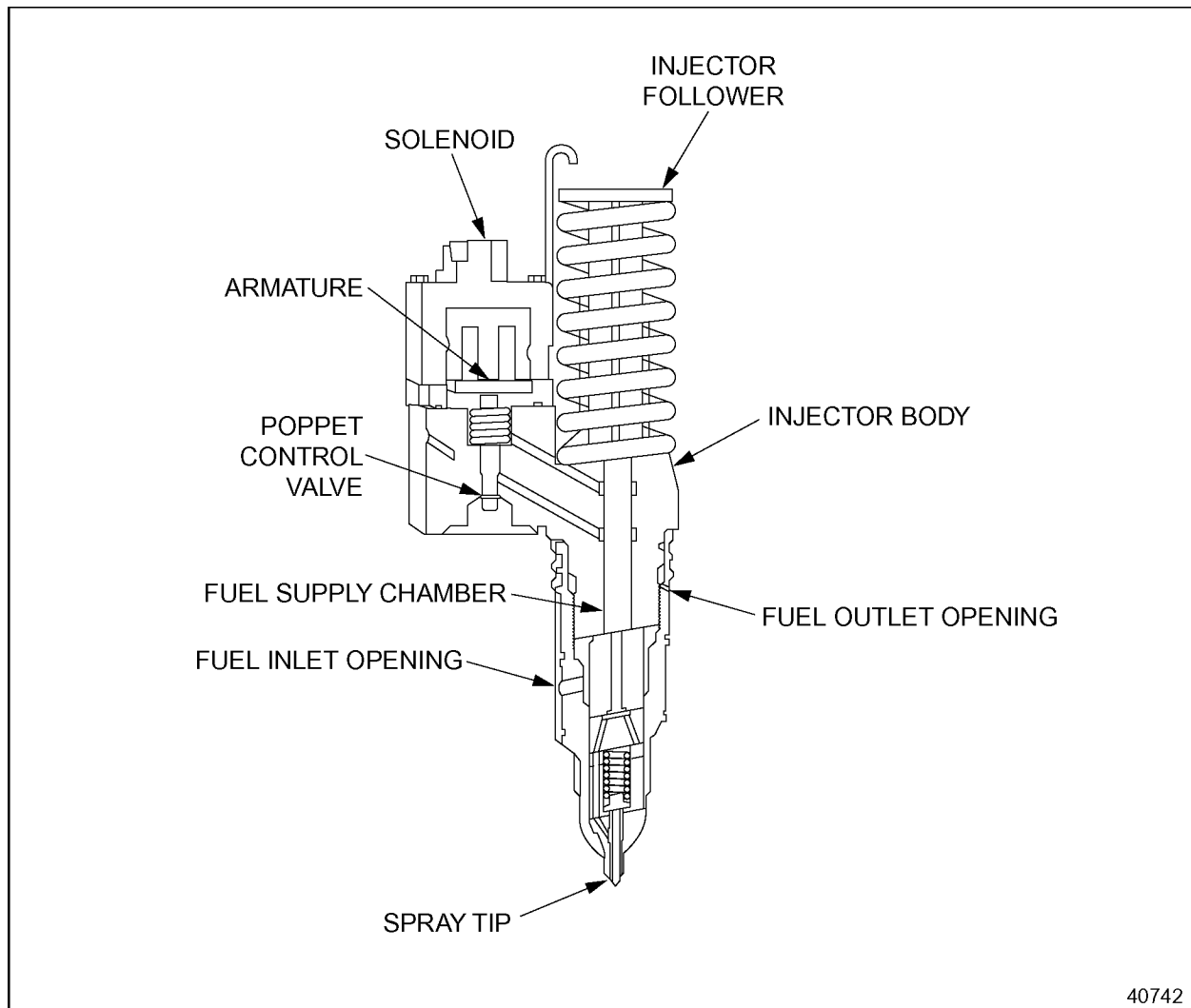

Figure 3-17 The Electronic Unit Injector

Because fuel injection is controlled electronically and is not tied to the injector in a mechanical sense, fuel metering becomes a function of a variety of selected parameters such as throttle position, engine speed, oil, water, and air temperatures, turbocharger boost levels, and barometric conditions.

3.7 POWER HARNESS

The OEM-supplied Power Harness supplies 12 or 24 volts to the ECM. The system must be sourced directly from the battery or bus bar.

3.7.1 DUAL-FUSE INSTALLATION

DDC's primary recommendation is a dual-fuse installation. This will provide redundancy on a critical circuit and prevent splicing of wire into fuse holders or power connectors. Dual-fuse installations have two lines wired in parallel. This configuration also allows for a greater distance from ECM to battery. See Figure 3-18.

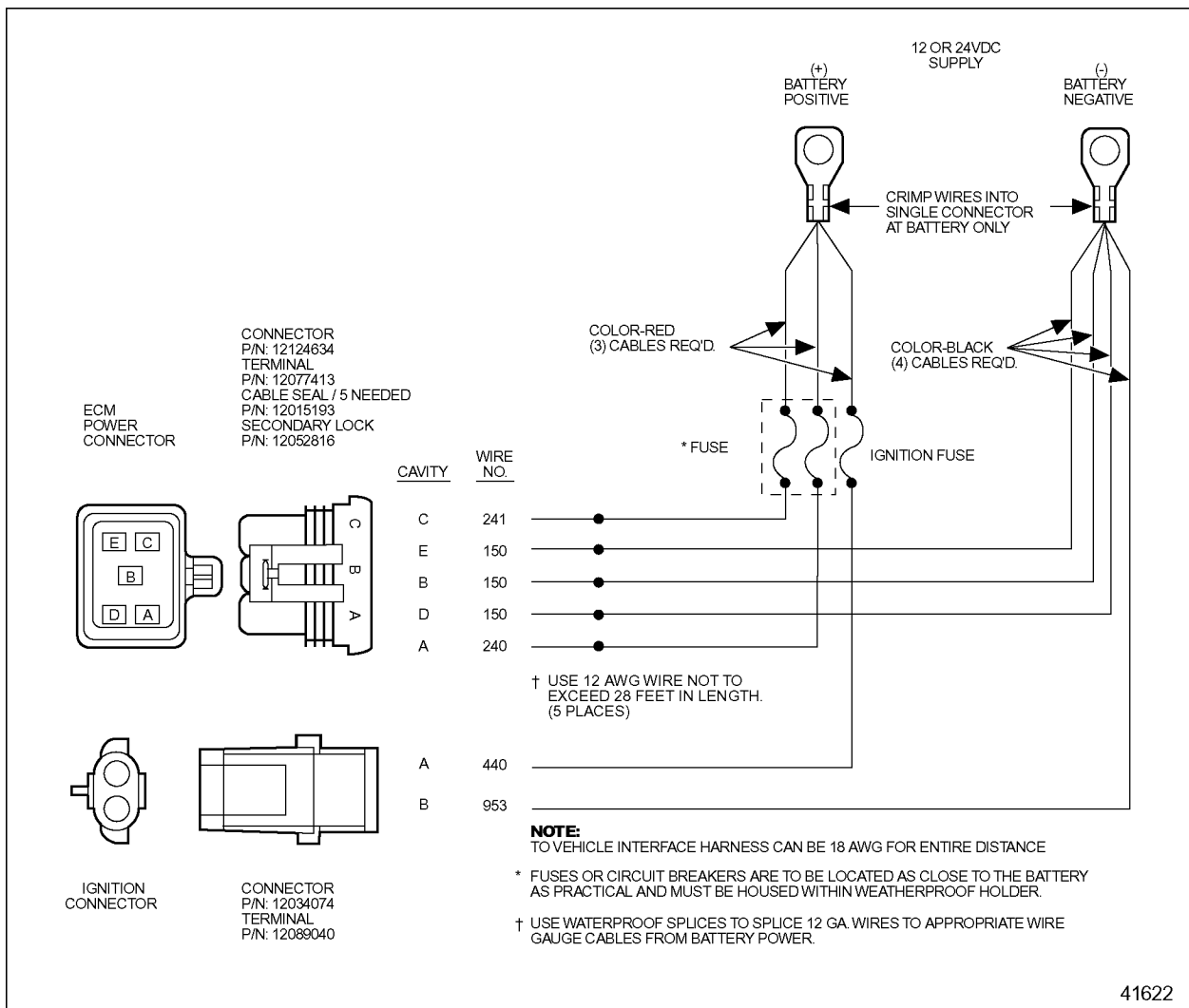

Figure 3-18 Power Harness - Single-ECM, Dual-Fuses

The resistance requirement is unchanged. The correct fuse size for a six cylinder engine is 2 @ 15 A.

NOTICE:

Connection to reverse polarity will damage the system if not properly fused.

To determine minimum cable gage based upon harness length from the battery source to the ECM, use the information listed in Table 3-16.

Length from ECM to Battery or Bus Bar		Minimum Wire Size		Total Resistance of Maximum Length	
U.S. (ft)	International (m)	U.S. (Ga.)	International (mm ²)	U.S. (mΩ)	International (mΩ)
0 to 28	0 to 6	12	2.5	24.8	22.8
28 to 44	6 to 10	10	4	24.57	23.55
44 to 70	10 to 14	8	6	24.58	21.98
70 to 110	14 to 26	6	10	24.7	23.66
110 to 178	26 to 40	4	16	25.0	23.2

Table 3-16 Power Harness Length Criteria for Dual Fuse Installations

NOTE:

For international wire sizes the harness length must be recalculated to meet the resistance requirement.

If larger than 12 AWG wire is required, it should be spliced to 12 AWG wire as close as possible to the connector (see Figure 3-19).

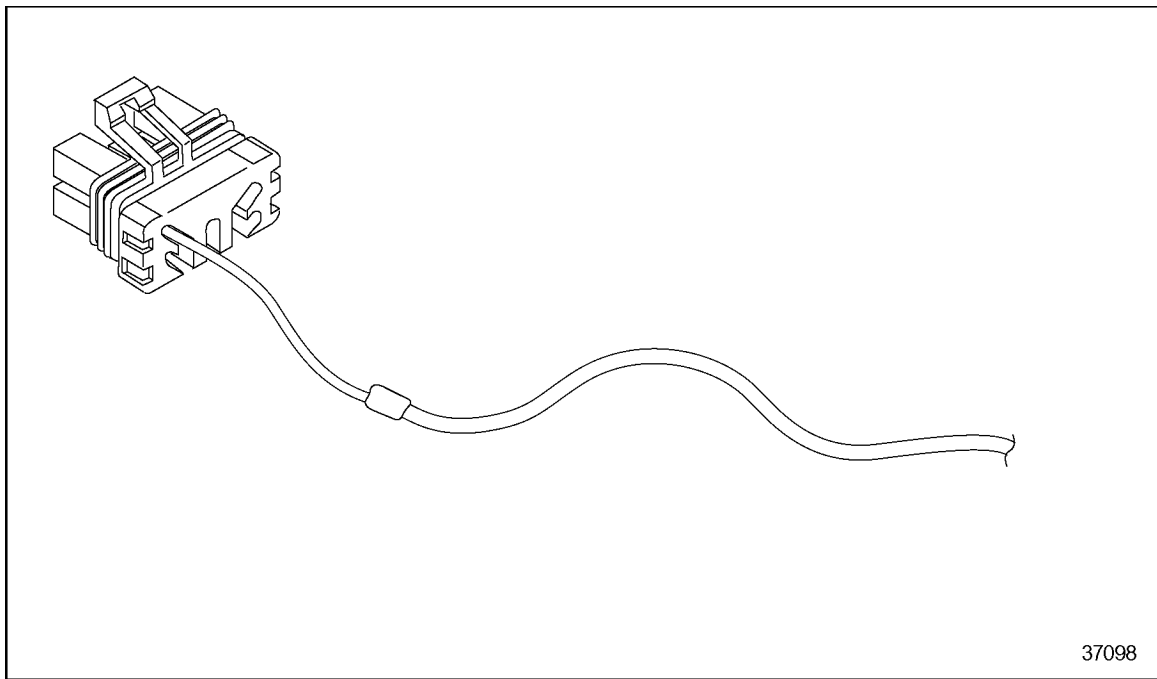

Figure 3-19 Spliced Power Connector Wire

These length and sizes are based on the use of stranded *annealed copper* not aluminum wire.

Splices must be soldered and sealed with a waterproof insulator. Alpha FIT-300, Raychem TAT-125 or any equivalent heat shrink - dual wall epoxy encapsulating adhesive polyolefin is required.

3.7.2 SINGLE-FUSE INSTALLATION

Single-fuse installations have one line from the battery to the ECM. The correct fuse size for a 6 cylinder engine is 1 @ 30 A.

NOTE:

A single-fuse installation does not provide redundancy on a critical circuit and does not prevent splicing of wire into fuse holders or power connectors.

Single fuse installations are simpler and less expensive than two fuse installations. See Figure 3-20.

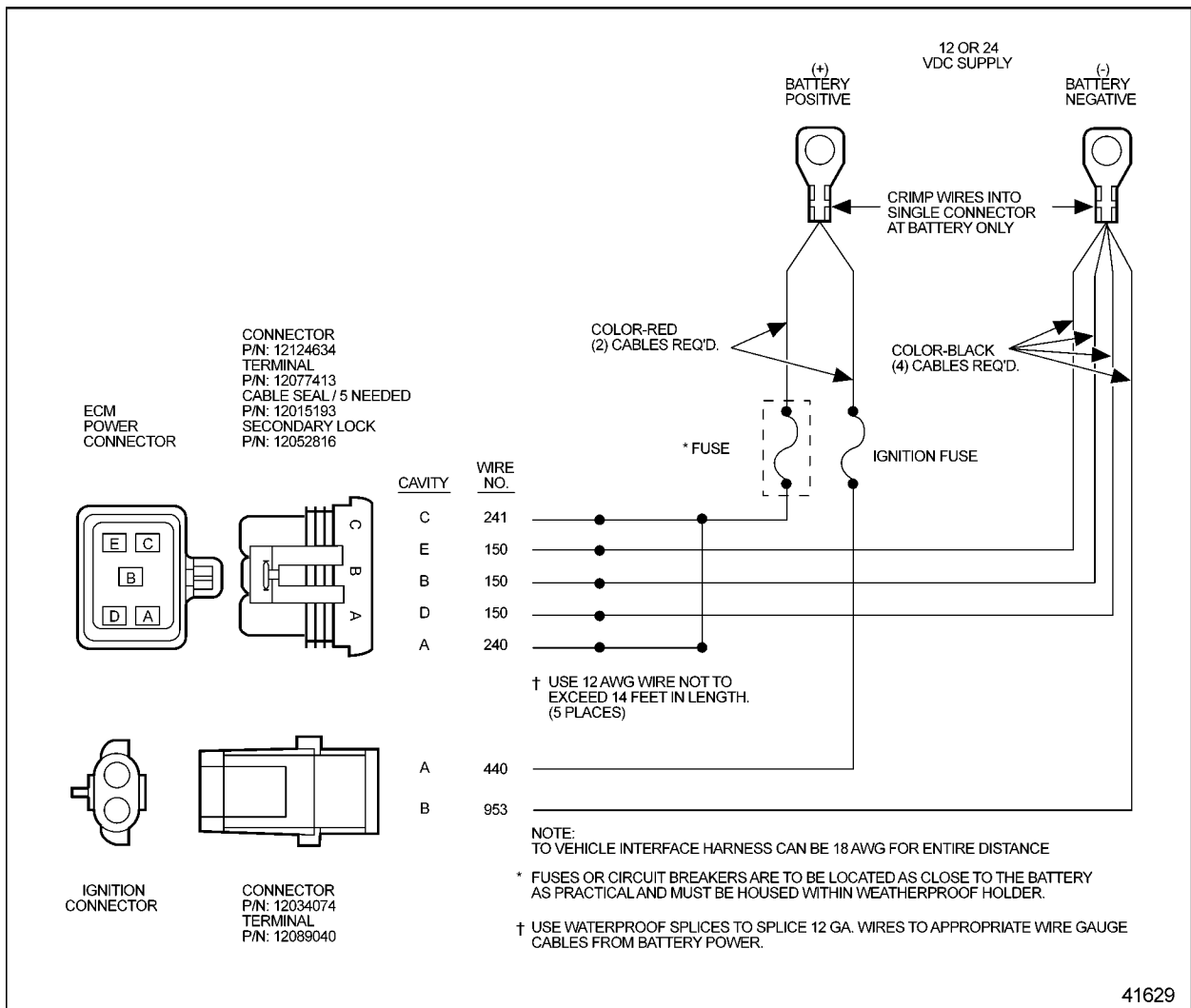

Figure 3-20 Power Harness - Single-ECM, Single-Fuse

The minimum cable gage based upon harness length from the battery source to the ECM is listed in Table 3-17.

Length from ECM to Battery or Bus Bar		Minimum Wire Size		Total Resistance of Maximum Length	
U.S. (ft)	International (m)	U.S. (Ga.)	International (mm ²)	U.S. (mΩ)	International (mΩ)
0 to 14	0 to 3	12	2.5	24.8	22.8
14 to 22	3 to 5	10	4	24.57	23.55
22 to 35	5 to 7	8	6	24.58	21.98
35 to 55	7 to 13	6	10	24.7	23.66
55 to 89	13 to 20	4	16	25.0	23.2

Table 3-17 Power Harness Length Criteria for Single Fuse Installations

If larger than 12 AWG wire is required, it should be spliced to 12 AWG wire as close as possible to the connector (see Figure 3-21).

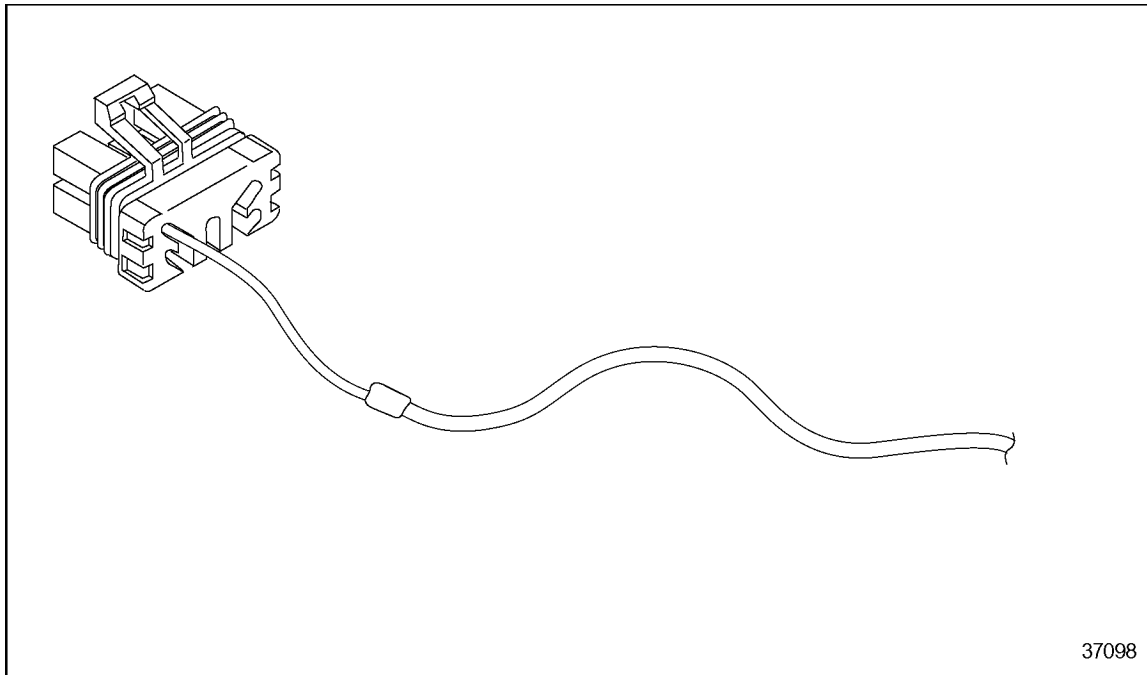

Figure 3-21 Spliced Power Connector Wire

These length and sizes are based on the use of stranded *annealed copper* not aluminum wire.

Splices must be soldered and sealed with a waterproof insulator. Alpha FIT-300, Raychem TAT-125 or any equivalent heat shrink - dual wall epoxy encapsulating adhesive polyolefin is required.

3.7.3 POWER HARNESS DESIGN

The following criteria are to be used when designing the Power Harness.



Criteria: Power Harness Design

The power connector is designed to accept 12 Ga. standard wall cable only.

The acceptable cable insulations are Teflon (EFTE), cross-link polyethylene (XLPE) or any equivalent self-extinguishing insulation such as GXL having a minimum rating of -40°C to 125°C. An equivalent insulation must meet the acceptable cable diameters 3.49 - 3.65 mm.

The conductor must be annealed copper not aluminum and must comply with the industry standard SAE J1128 document.

Splices must be soldered and sealed with a waterproof insulator. Alpha FIT-300, Raychem TAT-125 or any equivalent heat shrink - dual wall epoxy encapsulating adhesive polyolefin is required.

Detroit Diesel Corporation recommends color coding and hot stamping wire numbers in contrasting colors at intervals of four inches or less.

Wire Resistances

Twelve gage wires are required at the power harness connector. The total resistance of any power harness wire from the ECM to the battery (or bus bar) can not exceed 50 mΩ. The characteristics for Teflon coated and GXL type wire gages are listed in Table 3-18.

SAE Wire Gage	Metric Gage #	Area mm ²	Resistance mΩ/m	Resistance mΩ/ft @ 20°C	Resistance mΩ/ft @ 120°C	Diameter mm
16	1	1.129	15.300	4.66	6.50	0.72
14	2	1.859	9.290	2.83	3.94	1.18
12	3	2.929	5.900	1.80	2.50	1.86
10	5	4.663	3.720	1.13	1.58	2.97
8	8	7.277	2.400	0.73	1.02	4.63

Table 3-18 Wire Characteristics

Fuse Holder and Connector

The use of weatherproof blade type fuses, circuit breakers, or equivalent protection is required. Blade fuse holders may be purchased from DDC parts distribution network. The part numbers are listed in Table 3-19.

Part	Part Number
Fuse Holder	12033769
Cover	12033731
Terminal	12033997

Table 3-19 Fuse Holder Part Numbers

Power harness connectors and terminals may be purchased from the DDC parts distribution network. The part numbers are listed in Table 3-20.

Part	Part Number
Connector Assembly	12124634
Terminal	12077413
Cable Seal	12015193
Secondary Lock	12052816

Table 3-20 Power Harness Connector Assembly

3.7.4 POWER HARNESS INSTALLATION

The following criteria should be used when installing power harnesses. See Figure 3-22 for main power supply shutdown.



Criteria: Power Harness Installation

Power must be sourced directly from the battery or bus bar. An electrically solid connection to the battery or bus bar is required so the battery can filter electrical noise from the power lines. Power for other vehicle systems must not be sourced from the power harness assembly. **Do not** use chassis ground.

The DDEC ground wire must be electrically separate from chassis ground.

Power and ground bus bars may be used. The bus bar must be connected to the battery posts with 0 AWG or larger wire depending upon the total vehicle current requirement. The connecting wires must be as short as possible to minimize circuit resistance. **Do not** connect the ground wire to the chassis ground.

Provide maximum physical separation of the power harness from other vehicle electrical systems. Other electrical system cables should ideally be at least three feet away from the power harness and should not be parallel to the power harness. This will eliminate coupling electromagnetic energy from other systems into the power harness.

Do not route harness near any vehicle moving parts.

Do not route harness assembly near exhaust system or any high heat source.

Use a protective sheath and clips to prevent wires from being cut or frayed when weaving a harness through the frame.

THIS PAGE INTENTIONALLY LEFT BLANK

3.8 POWER SUPPLY

Normal operating voltage for DDEC, listed in Table 3-21, is ECM dependent.

NOTICE:	
Operating the ECM over the voltage limits listed in Table 3-21 will cause damage to the ECM.	

Part Number	Description	Normal Operating Voltage	Voltage Limits
23519307	DDEC IV - Standard On-highway ECM	11-14 Volts DC	14 Volts
23519308	DDEC IV - Universal ECM	11-32 Volts DC	32 Volts

Table 3-21 Operating Voltage

Operating the ECM between 6 and 11 volts may result in degraded engine operation. (Transient operation in this range during engine starting is considered normal for 12 volt systems.)

NOTICE:	
Reversing polarity will cause damage to the ECM if the power harness is not properly fused.	

3.8.1 AVERAGE BATTERY DRAIN CURRENT

The average battery drain current for various engines may be found in the following tables. The current draw for a single ECM configurations is listed in Table 3-22.

Engine	Condition	Current for 12V System (Average DC)	Current for 24V System (Average DC)
Single ECM	Ignition Off	20 mA	25 mA
Single ECM	Ignition On & Engine Stopped	500 mA	400 mA

NOTE: Add up to 1.5 A to the current draw total for every digital output.

NOTE: Power supply and harness must be able to transition from 0 A to 30 A in .6 milliseconds with no more than 0.75 volt loss at the ECM.

NOTE: Add 6.0A to the current draw for the two Variable Pressure Output Devices (VPOD).

Table 3-22 Average Battery Drain Current for Single ECM Configurations

The current draw for the Series 60 is listed in Table 3-23.

Engine	Condition	Current for 12V System (Average DC)	Current for 24V System (Average DC)
8 Cylinder	Idle	1.0 A	0.8 A
6 Cylinder	Rated RPM, Full Load	4.5 A	3.0 A

NOTE: Add up to 1.5 A to the current draw total for every digital output.

NOTE: Power supply and harness must be able to transition from 0 A to 30 A in 0.6 milliseconds with no more than 0.75 volt loss at the ECM.

NOTE: Add 6.0A to the current draw for the two Variable Pressure Output Devices (VPOD).

Table 3-23 Average Battery Drain Current for the Series 60

3.8.2 REQUIREMENTS FOR 12 OR 24 VOLT SYSTEM

The alternator size must be suitable for the amount of current drawn as listed in Table 3-22 and Table 3-23.

The ECM will not activate injectors at speeds below 120 RPM.

3.8.3 MAIN POWER SHUTDOWN

The main power supply shutdown schematic shows the DDC approved method for main power switch implementation. See Figure 3-22.

NOTE:

Disconnecting positive power is not sufficient to isolate the ECM for welding purposes.

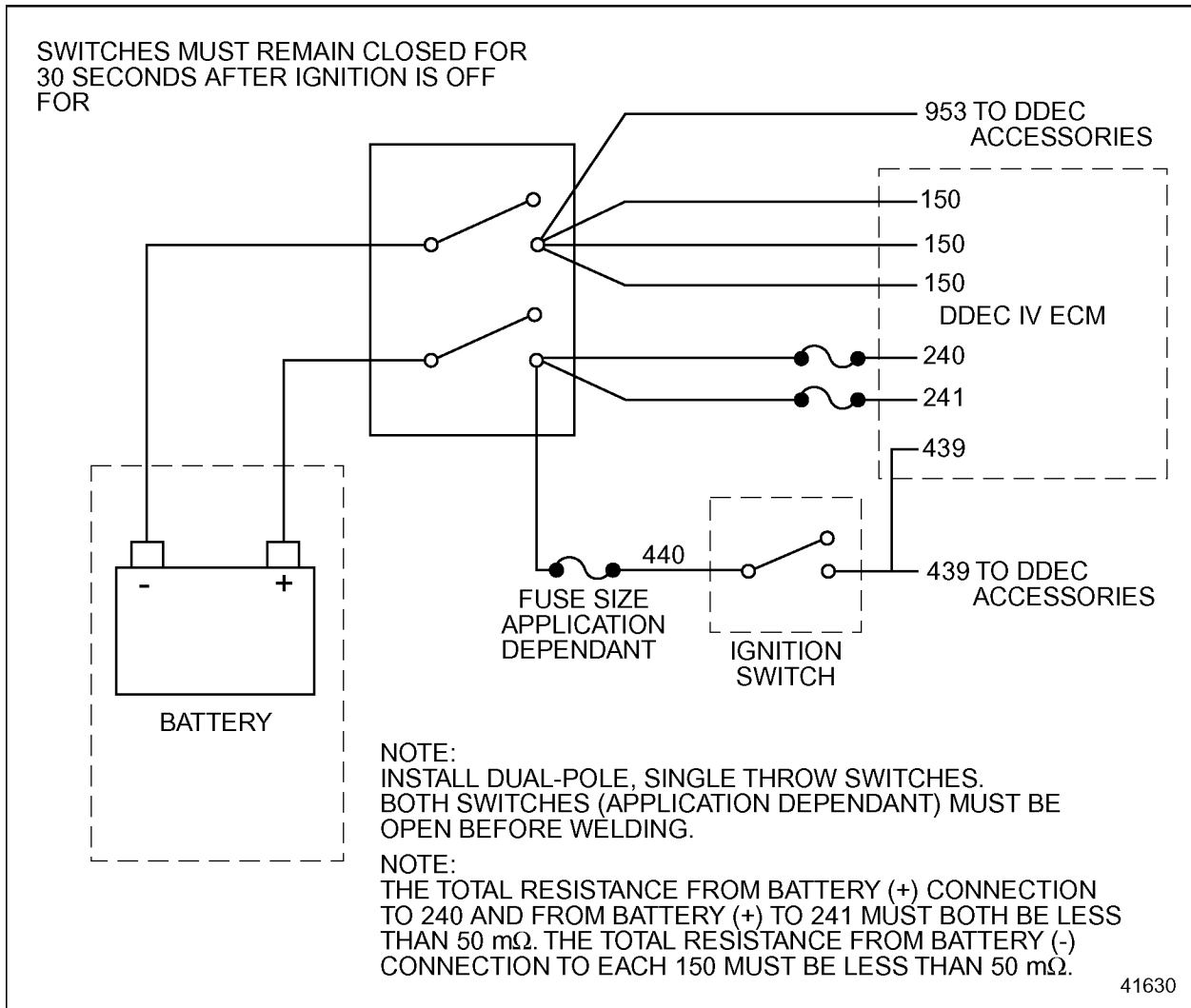

Figure 3-22 Main Power Supply Shutdown 12 or 24 Volt Systems

3.8.4 WELDING CAUTION

Prior to any welding on the vehicle or equipment, the following precautions must be taken to avoid damage to the electronic controls and/or the engine (see Figure 3-23).

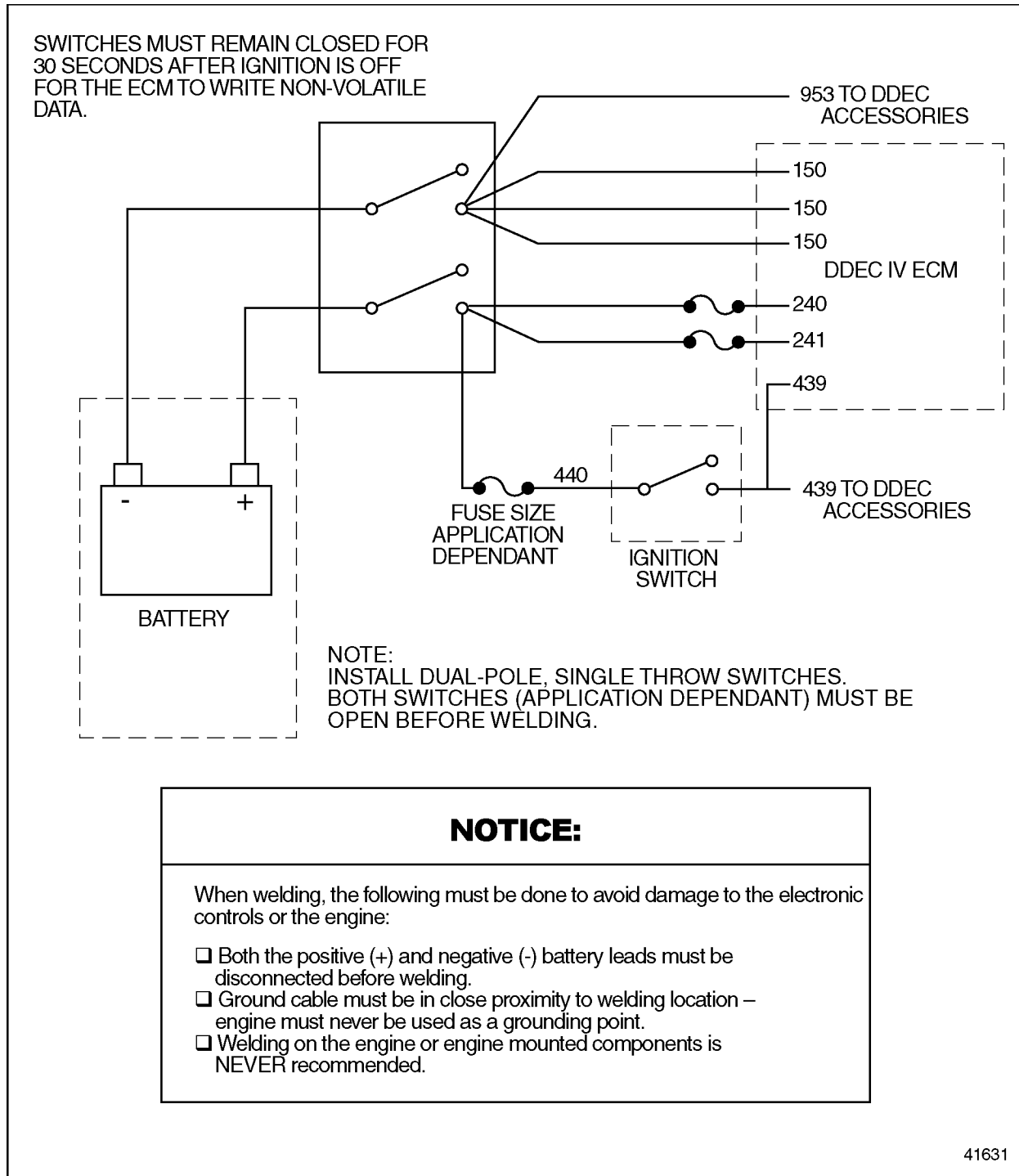

Figure 3-23 Welding Precaution

3.9 FUSES

A Battery (+) fuse and an ignition circuit fuse must be provided by the vehicle wiring harness. Blade-type automotive fuses are normally utilized; however, manual or automatic reset circuit breakers which meet the following requirements are also acceptable. The fuse voltage rating must be compatible with the ECU's maximum operating voltage.

 **CAUTION:**

FIRE

To avoid injury from fire, additional loads should not be placed on existing circuits. Additional loads may blow the fuse (or trip the circuit breaker) and cause the circuit to overheat and burn.

 **CAUTION:**

FIRE

To avoid injury from fire, do not replace an existing fuse with a larger amperage fuse. The increased current may overheat the wiring, causing the insulation and surrounding materials to burn.

The ignition fuse current rating must be sized for the loads utilized in each application; however, a rating of between 5 and 10 amps is usually sufficient.

The Battery (+) fuse current rating must satisfy two criteria:

- Must not open during normal operation
- Must open before the ECU is damaged during a reverse battery condition

Acceptable blow times versus current and temperature derating characteristics are listed in Table 3-24 and Table 3-25.

% of Rated Fuse Current	Minimum Blow Time	Maximum Blow Time
100%	100 hours	-
135%	1 minute	30 minutes
200%	6 seconds	40 seconds

Table 3-24 Fuse Current and Blow Time

Temperature	% of Rated Fuse Current
-40°C	110% max
+25°C	100%
+120°C	80% min

Table 3-25 Fuse Temperature and Current

3.10 CONNECTORS

The connectors listed in this section are required to properly wire a Detroit Diesel engine equipped with DDEC.

3.10.1 ECM VEHICLE HARNESS CONNECTORS

The ECM vehicle harness connections are on the right side of the ECM (see Figure 3-24).

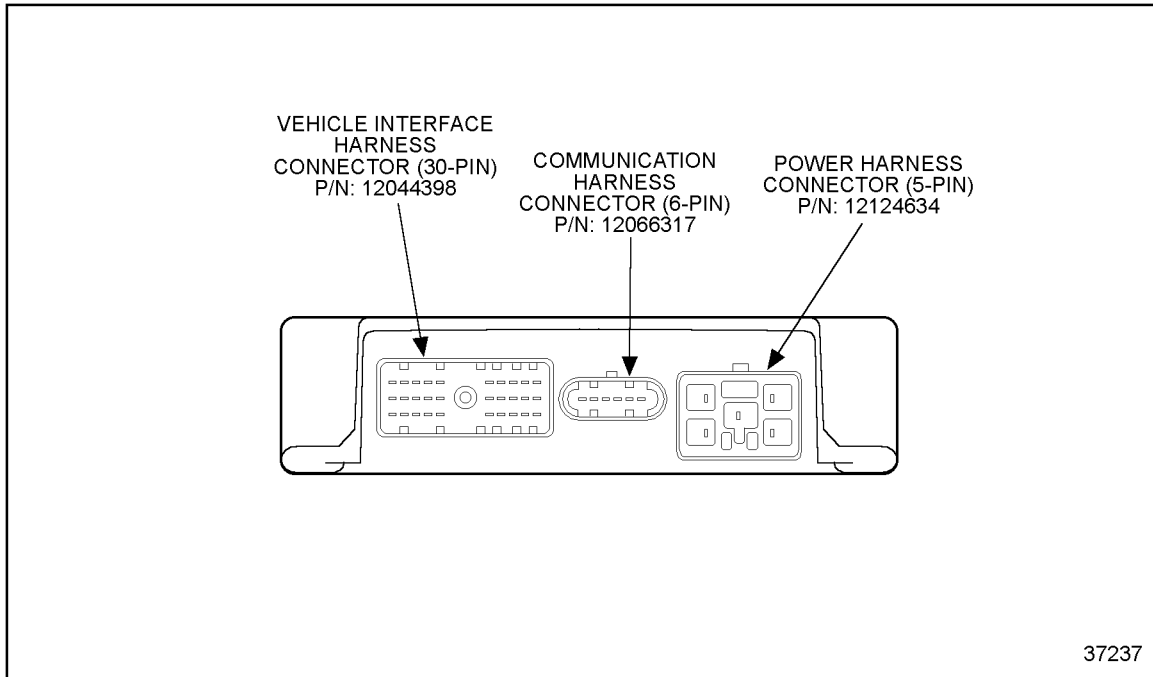

Figure 3-24 ECM Right Side, Vehicle Harness Connections

VIH-to-ECM Connector

The wire comb is a strain relief for the back of the VIH connector to prevent water from entering the connector from the back. To use the wire comb, the original bolt in the VIH connector must be removed and discarded. The wire comb should be attached to the back of the VIH connector. The new bolt must be inserted through the assembly and used to tighten the VIH connector into the ECM. These parts listed in Table 3-26 are available from the Detroit Diesel Parts Distribution Center. The wire comb is required for all Series 50 applications.

Description	Part Number
Wire Comb	12110546
Bolt	12129426

Table 3-26 Wire Comb Part Numbers

The wiring for the 30-pin VIH-to-ECM connector is listed in Table 3-27.

Cavity	Wire No.	Label	VIH-to-ECM Connector
H-3	115	COOLANT LEVEL	
D-2	417	LIMITING SPEED GOVERNOR	
B-1	419	CHECK ENGINE LIGHT	
B-3	439	IGNITION	
E-1	451	DIGITAL INPUT #1	
F-3	499	DIGITAL OUTPUT #1	
K-1	505	TACHOMETER DRIVE	
B-2	509	STOP ENGINE LIGHT	
D-1	510	OI THERMOSTAT OR PTO OR EXHAUST BACK PRESSURE SENSOR (COACH ONLY)	
H-1	523	DIGITAL INPUT #7	
H-2	524	DIGITAL INPUT #8	
G-1	528	DIGITAL INPUT #4	
J-2	531	DIGITAL INPUT #10	
J-1	541	DIGITAL INPUT #9	
F-1	542	DIGITAL INPUT #2	
G-2	543	DIGITAL INPUT #5	
F-2	544	DIGITAL INPUT #3	
G-3	545	DIGITAL INPUT #6	
A-2	555	DIGITAL OUTPUT #2	
E-2	556	VEHICLE SPEED (+)	
E-3	557	VEHICLE SPEED (-)	
K-2	583	DIGITAL INPUT #11	
D-3	749	ESS OR FIRE TRUCK PRESSURE	
C-2	900	J1587 DATA LINK (+)	
C-1	901	J1587 DATA LINK (-)	
J-3	908	VARIABLE SPEED FAN OR PWM TRANSMISSION OR OI ALARM	
A-3	916	SENSOR SUPPLY (5VDC)	
C-3	952	SENSOR RETURN	
K-3	979	DIGITAL INPUT #12	
A-1	988	DIGITAL OUTPUT #3	

Table 3-27 Typical VIH-to-ECM Connector Pin Definitions — Truck/Coach Applications

The 30-pin VIH-to-ECM connector, listed in Table 3-28, is a Metri-Pack 150 series pull-to-seat connector.

Part	Part Number
Connector	12034398
Terminal	12103881
Plug	12034413

Table 3-28 30-pin VIH-to-ECM Connector

The ECM connector assembly center screw must be torqued to 22–28 in.-lb. (2.49–3.16 N·m). The 30-pin VIH-to-ECM connector wiring for urban bus applications is listed in Table . 3-29.

Cavity	Wire No.	Label	VIH-to-ECM Connector
H-3	115	COOLANT LEVEL	
D-2	417	LIMITING SPEED GOVERNOR	
B-1	419	CHECK ENGINE LIGHT	
B-3	439	IGNITION	
E-1	451	DIGITAL INPUT #1	
F-3	499	DIGITAL OUTPUT #1	
K-1	505	TACHOMETER DRIVE	
B-2	509	STOP ENGINE LIGHT	
D-1	510	PTO OR EXHAUST BACKPRESSURE (OPTIONAL)	
H-1	523	DIGITAL INPUT #7	
H-2	524	DIGITAL INPUT #8	
G-1	528	DIGITAL INPUT #4	
J-2	531	DIGITAL INPUT #10	
J-1	541	DIGITAL INPUT #9	
F-1	542	DIGITAL INPUT #2	
G-2	543	DIGITAL INPUT #5	
F-2	544	DIGITAL INPUT #3	
G-3	545	DIGITAL INPUT #6	
A-2	555	DIGITAL OUTPUT #2	
E-2	556	VEHICLE SPEED (+)	
E-3	557	VEHICLE SPEED (-)	
K-2	583	DIGITAL INPUT #11	
D-3	749	EXHAUST TEMPERATURE	
C-2	900	J1587 DATA LINK (+)	
C-1	901	J1587 DATA LINK (-)	
J-3	908	PWM #1 – VARIABLE SPEED FAN OR PWM TRANSMISSION	
A-3	916	SENSOR SUPPLY (5VDC)	
C-3	952	SENSOR RETURN	
K-3	979	DIGITAL INPUT #12	
A-1	988	DIGITAL OUTPUT #3	

Table 3-29 Typical VIH-to-ECM Connector Pin Definitions — Urban Bus Applications

The wiring for the 30-pin VIH-to-ECM connector for natural gas applications is listed in Table 3-30.

Cavity	Wire No.	Label	VIH-to-ECM Connector
H-3	115	COOLANT LEVEL	
D-2	417	LIMITING SPEED GOVERNOR	
B-1	419	CHECK ENGINE LIGHT	
B-3	439	IGNITION	
E-1	451	DIGITAL INPUT #1	
F-3	499	DIGITAL OUTPUT #1	
K-1	505	TACHOMETER DRIVE	
B-2	509	STOP ENGINE LIGHT	
D-1	510	RELATIVE HUMIDITY	
H-1	523	DIGITAL INPUT #7	
H-2	524	DIGITAL INPUT #8	
G-1	528	DIGITAL INPUT #4	
J-2	531	DIGITAL INPUT #10	
J-1	541	DIGITAL INPUT #9	
F-1	542	DIGITAL INPUT #2	
G-2	543	DIGITAL INPUT #5	
F-2	544	DIGITAL INPUT #3	
G-3	545	DIGITAL INPUT #6	
A-2	555	DIGITAL OUTPUT #2	
E-2	556	VEHICLE SPEED (+)	
E-3	557	VEHICLE SPEED (-)	
K-2	583	PSV DIAGNOSTIC	
D-3	749	AMBIENT AIR TEMPERATURE	
C-2	900	J1587 DATA LINK (+)	
C-1	901	J1587 DATA LINK (-)	
J-3	908	VARIABLE SPEED FAN OR PWM TRANSMISSION	
A-3	916	SENSOR SUPPLY (5VDC)	
C-3	952	SENSOR RETURN	
K-3	979	DIGITAL INPUT #12	
A-1	988	DIGITAL OUTPUT #3	

Table 3-30 Typical VIH-to-ECM Connector Pin Definitions — Natural Gas Applications

Power Harness-to-ECM Connector

See Figure 3-25 for the wiring for the ECM-to-Power Harness connector. Refer to section 3.7 for more information on the Power Harness.

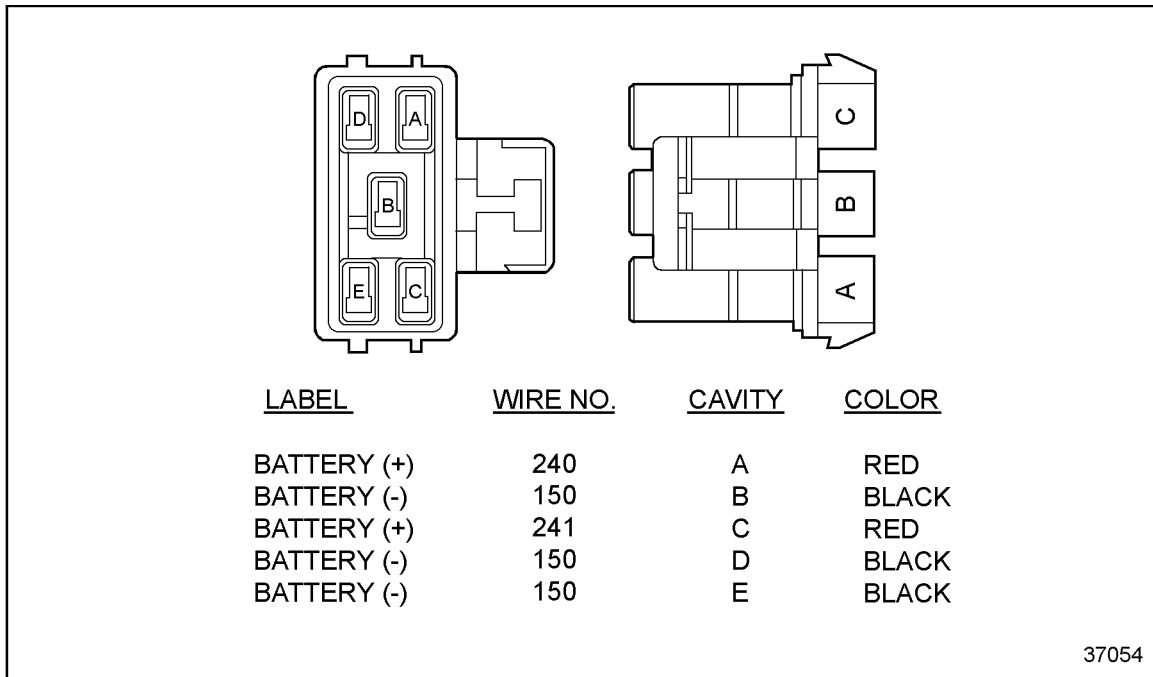

Figure 3-25 Five-Pin Power Harness Connector

The parts for the five-pin Power Harness Connector are listed in Table 3-31.

Part	Part Number
Connector	12124634
Terminal	12077413
Cable Seal	12015193
Secondary Lock	12052816

Table 3-31 Five-pin Power Harness Connector Part Numbers

Communication Harness-to-ECM Connector

See Figure 3-26 for the wiring for the ECM-to-Communication Harness connector. Refer to section 3.5 for more information on the Communication Harness.

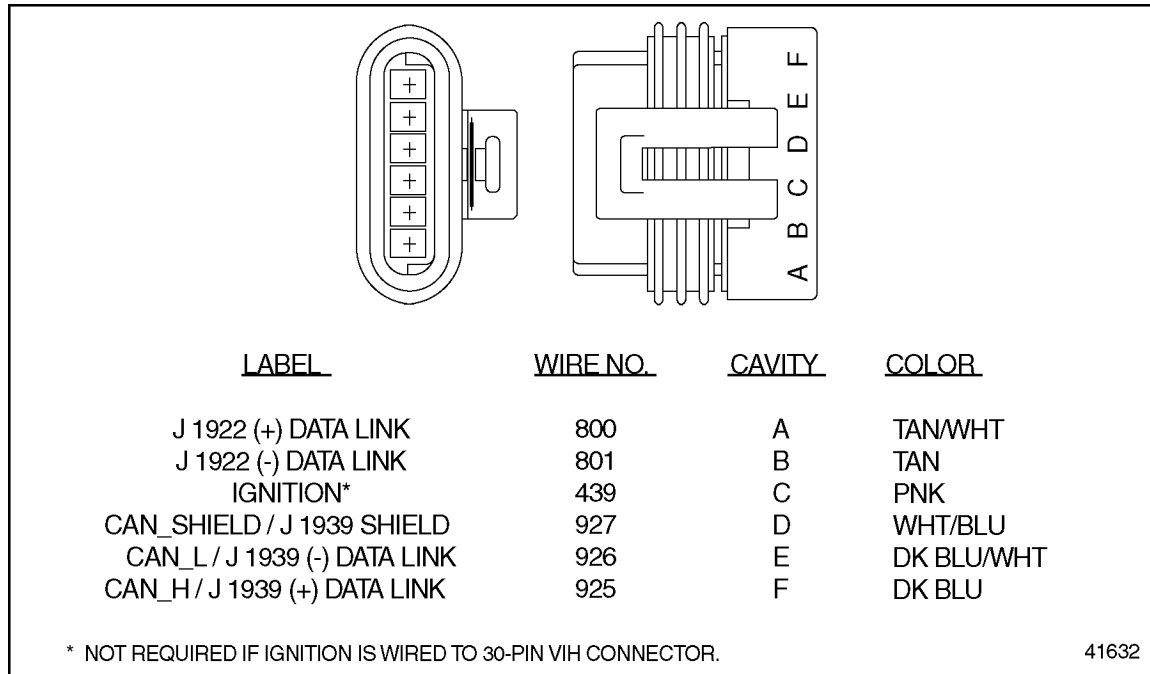

Figure 3-26 Communication Harness Connector

The part numbers for the Communication Harness Connector are listed in Table 3-32.

Part	Part Number
Connector	12066317
Terminal	12103881
Plug	12034413

Table 3-32 Communication Harness Connector Part Numbers

3.10.2 ECM ENGINE HARNESS CONNECTORS

The ECM engine harness connections are on the left side of the ECM and come factory installed (see Figure 3-27).

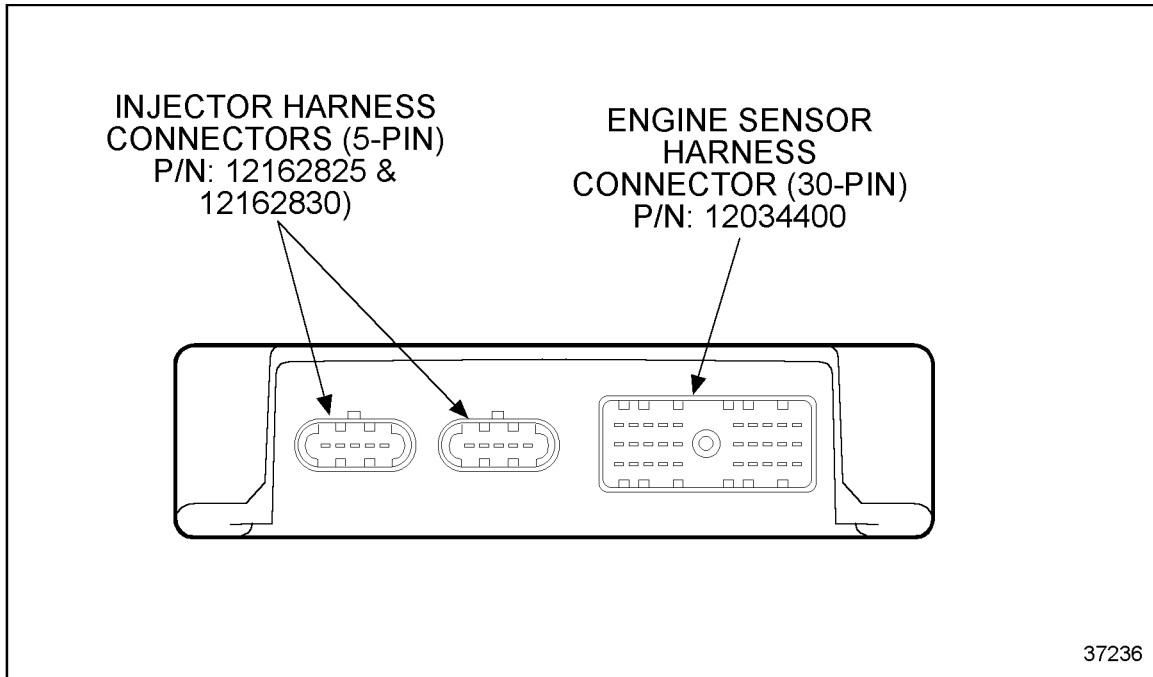

Figure 3-27 ECM Left Side, Engine Harness Connections

ESH-to-ECM Connector

The wiring for the 30-pin ESH-to-ECM connector is listed in Table 3-33.

Cavity	Wire No	Label	ESH-to-ECM Connector
T-1	109	TRS (-)	
T-2	110	TRS (+)	
S-2	111	SRS (+)	
S-1	112	SRS (-)	
R-2	120	OIL TEMPERATURE	
N-2	132	AIR TEMPERATURE	
P-3	133	COOLANT TEMP	
W-1	416	SENSOR SUPPLY (5VDC)	
P-1	432	TURBO BOOST	
Y-2	452	SENSOR RETURN (ENGINE)	
R-3	472	FUEL TEMP	
P-2	530	OIL PRESSURE	
S-3	561	ENGINE BRAKE MED	
T-3	562	ENGINE BRAKE LO	
W-3	563	DIGITAL OUTPUT #6	
X-3	564	DIGITAL OUTPUT #5	
Y-3	565	DIGITAL OUTPUT #4	
X-1	573	TURBO SPEED	
L-1	904	BAROMETRIC PRESSURE	
M-1	905	TURBO COMPRESSOR IN TEMP	
N-1	906	TURBO COMPRESSOR OUT TEMP	
R-1	907	EGR TEMPERATURE	
Y-1	909	EGR CONTROL	
W-2	910	OI STARTER	
X-2	911	VGT CONTROL	
L-3	925	J1939 (+)	
M-3	926	J1939 (-)	
N-3	927	J1939 SHIELD	
M-2	958	EGR DELTA PRESSURE	
L-2	976	RELATIVE HUMIDITY	

41449

Table 3-33 Typical ESH-to-ECM Connector Pin Definitions — Series 60

The 30-pin ESH-to-ECM connector, listed in Table 3-34, is a Metri-Pack 150 series pull-to-seat connector.

Part	Part Number
Connector	12034400
Terminal	12103881
Seal	In Connector
Plug	12034413

Table 3-34 30-pin ESH-to-ECM Connector

The wiring for the 30-pin ESH-to-ECM connector for the Series 50 is listed in Table 3-35.

Cavity	Wire No	Label	ESH-to-ECM Connector
T-1	109	TRS (-)	
T-2	110	TRS (+)	
S-2	111	SRS (+)	
S-1	112	SRS (-)	
R-2	120	OIL TEMPERATURE	
N-2	132	AIR TEMPERATURE	
P-3	133	COOLANT TEMPERATURE	
W-1	416	SENSOR SUPPLY (5VDC)	
P-1	432	TURBO BOOST	
Y-2	452	SENSOR RETURN (ENGINE)	
R-3	472	FUEL TEMPERATURE	
P-2	530	OIL PRESSURE	
S-3	561	VGT POWER	
T-3	562	EGR SOLENOID CONTROL	
W-3	563	DIGITAL OUTPUT #6	
X-3	564	DIGITAL OUTPUT #5	
Y-3	565	DIGITAL OUTPUT #4	
X-1	573	TURBO SPEED	
L-1	904	AIR FILTER RESTRICTION (MAS ONLY)	
M-1	905	FUEL FILTER RESTRICTION (MAS ONLY)	
N-1	906	ADD COOLANT LEVEL (MAS ONLY) — 2002–2003 COMPRESSOR TEMP OUT (330 hp only) — 2004 – Present	
R-1	907	EGR TEMPERATURE	
Y-1	909	PWM #2 – NOT USED	
W-2	910	PWM #3 –NOT USED	
X-2	911	PWM #4 –VGT CONTROL	
L-3	925	J1939 (+)	
M-3	926	J1939 (-)	
N-3	927	J1939 SHIELD	
M-2	958	EGR DELTA PRESSURE	
L-2	976	OIL LEVEL (MAS ONLY)	

Table 3-35 Typical ESH-to-ECM Connector Pin Definitions — Series 50

The wiring for the 30-pin ESH-to-ECM connector on a natural gas engine is listed in Table 3-36.

Cavity	Wire No	Label	ESH-to-ECM Connector
T-1	109	TRS (-)	
T-2	110	TRS (+)	
S-2	111	SRS (+)	
S-1	112	SRS (-)	
R-2	120	EXHAUST TEMPERATURE	
N-2	132	INTAKE AIR TEMPERATURE	
P-3	133	COOLANT TEMPERATURE	
W-1	416	SENSOR SUPPLY (5VDC)	
P-1	432	INTAKE MANIFOLD PRESSURE	
Y-2	452	SENSOR RETURN (ENGINE)	
R-3	472	FUEL TEMPERATURE	
P-2	530	OIL PRESSURE	
S-3	561	THROTTLE SUPPLY	
T-3	562	FUEL SHUTOFF	
W-3	563	DIGITAL OUTPUT #6	
X-3	564	DIGITAL OUTPUT #5	
Y-3	565	DIGITAL OUTPUT #4	
X-1	573	SNEF	
L-1	904	BAROMETRIC PRESSURE	
M-1	905	FUEL PRESSURE	
N-1	906	OXYGEN SENSOR	
R-1	907	THROTTLE PLATE POSITION	
Y-1	909	THROTTLE ACTUATOR	
W-2	910	UNUSED	
X-2	911	VGT CONTROL	
L-3	925	J1939 (+)	
M-3	926	J1939 (-)	
N-3	927	J1939 SHIELD	
M-2	958	PULSE STEPPER VALVE	
L-2	976	KNOCK SENSOR	

Table 3-36 Typical ESH-to-ECM Connector Pin Definitions — Natural Gas Applications

3.10.3 FCI APEX CONNECTORS

These FCI Apex connectors are the OEM's responsibility. These connectors are used for Series 60 and natural gas applications only. The 10-pin connector is the OEM interface to the ESH and the 4-pin is used for the RH/TCI Temperature Sensor (see Figure 3-28 and Figure 3-29).

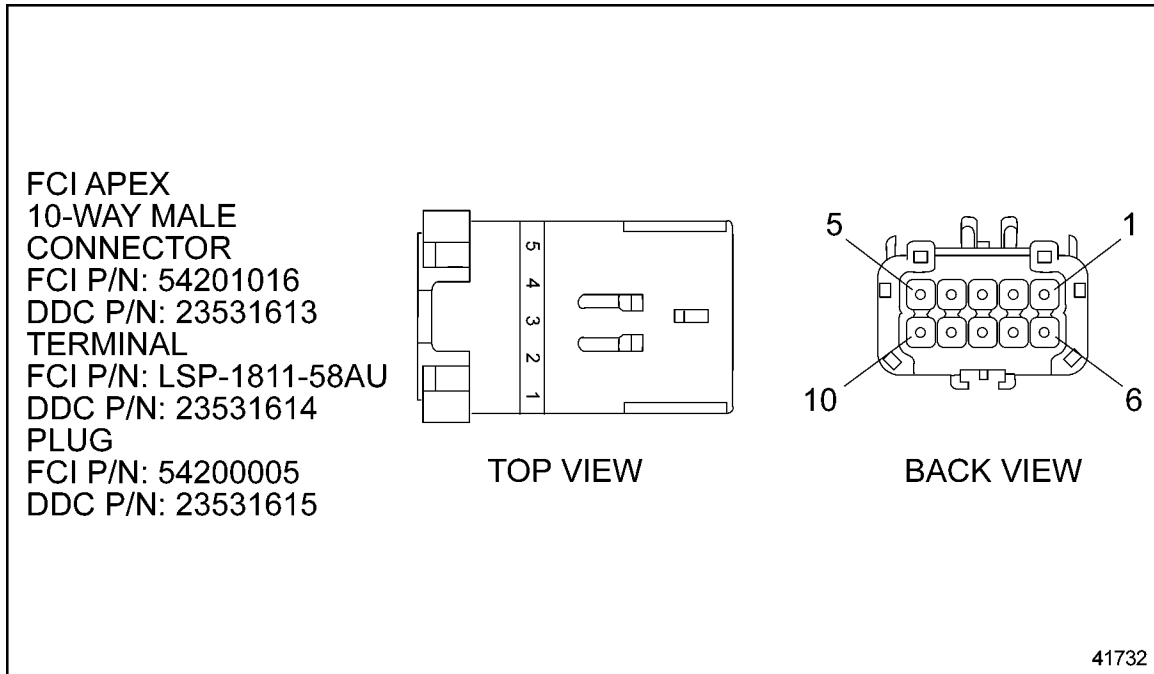

Figure 3-28 Ten-pin OEM Engine Sensor Harness Interface Connector

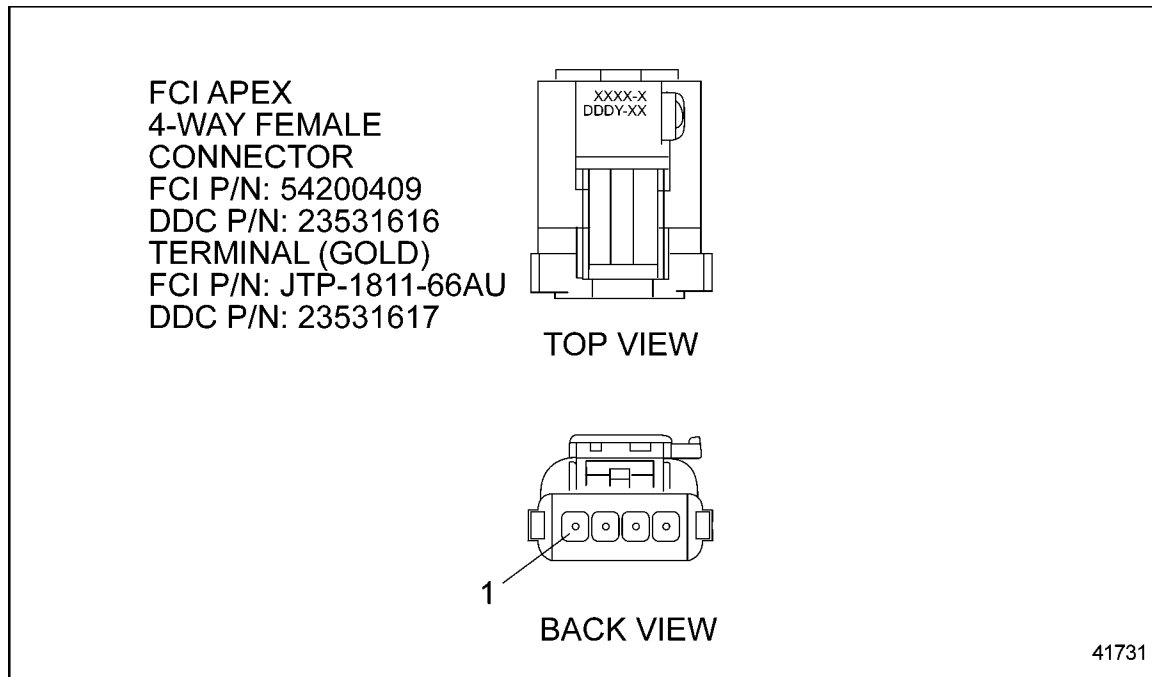

Figure 3-29 Relative Humidity/Turbo Compressor Inlet Temperature Sensor Connector

FCI Apex connectors are available from:

NTI, LLC

300 Randall Street, Suit B
Greer, SC 29651
Telephone: 864-877-4800
Fax: 864-877-2997

FCI Automotive

Telephone: 1-800-303-3577
734-728-2100

3.10.4 DATA LINK CONNECTORS

The connectors used to connect the data links are a 6-pin Deutsch connector for the J1708/J1587 Data Link or a 9-pin Deutsch connector for the J1939 and J1587 Data Link. DDC recommends that the OEM-supplied Data Link Connector be conveniently positioned in a well protected location facilitating subsequent DDDL/DDR usage (i.e., reprogramming, diagnostics, etc.).

SAE J1939/J1587 Data Link Nine-pin Connector (Recommended)

The SAE J1939/J1587 nine-pin data link connector is the recommended diagnostic connector. The components listed in Table 3-37 are required to incorporate an SAE J1939/J1587 Data Link in a VIH so a DDR or other diagnostic devices can be attached without a unique jumper:

Component	DDC Part Number	Deutsch Part Number
Nine-pin Deutsch Connector	23529496	HD10-9-1939P
Connector Cover	23529497	HDC 16-9
Two (2) Cavity Plugs	23507136	114017
Seven (7) Terminals	23507132	0460-202-16141

Table 3-37 Required Components to Incorporate an SAE J1939/J1587 Data Link in the VIH

The following illustration shows the wiring for the nine-pin connector (see Figure 3-30).

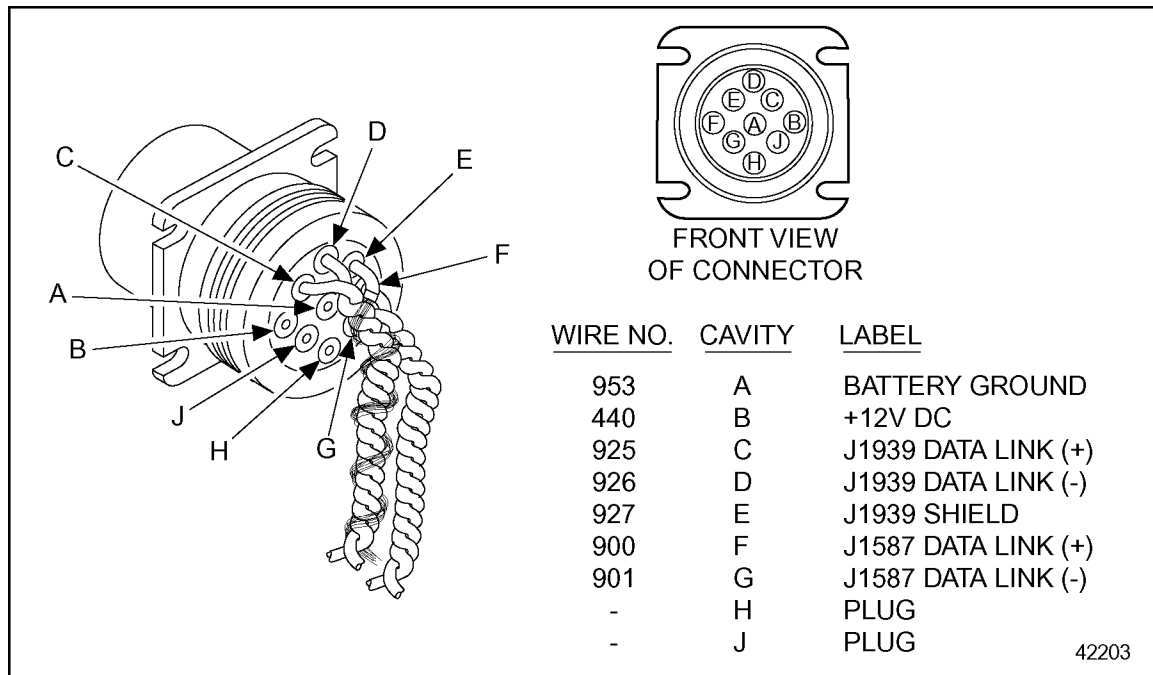

Figure 3-30 Wiring for Nine-pin Data Link Connector

The maximum length for the SAE J1939 Data Link is 130 ft (40 m).

The SAE J1587/J1708 Data Link must be twisted at a minimum of 12 turns per foot. The maximum length is 130 ft (40 m).

SAE J1708/J1587 Data Link Six-pin Connector

The components listed in Table 3-38 are required to incorporate a SAE J1708/J1587 Data Link in a VIH so a DDR or other diagnostic devices can be attached without a unique jumper:

Component	DDC Part Number	Deutsch Part Number
Six-pin Deutsch Connector	23513052	HD-10-6-12P
Connector Cover	23513054	HDC-16-6
Two (2) Cavity Plugs	23507136	114017
Four (4) Terminals	23513053	0460-220-1231

Table 3-38 Required Components to Incorporate an SAE J1939/J1587 Data Link in the VIH

The following illustration shows the wiring for the 6-pin connector (see Figure 3-31).

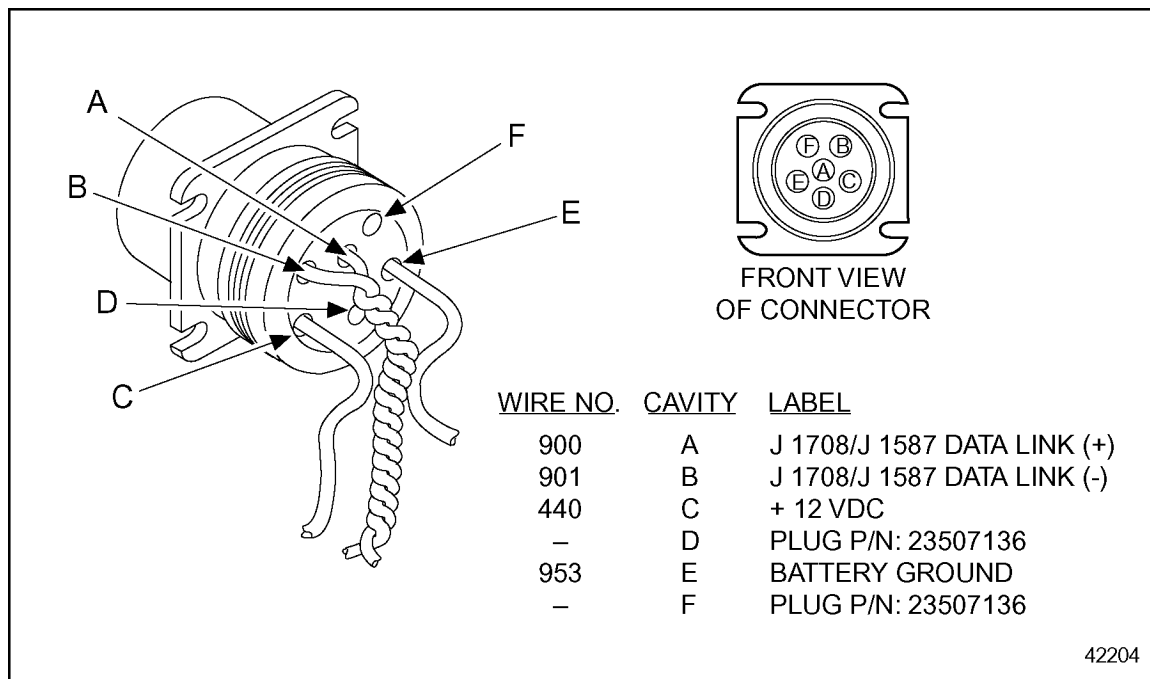

Figure 3-31 Wiring for Six-pin Data Link Connector

3.11 WIRES AND WIRING

Detroit Diesel Corporation recommends color coding and hot stamping wire numbers in contrasting colors at intervals of four inches or less.

3.11.1 GENERAL REQUIREMENTS

NOTE:

Avoid renumbering DDC circuits since all troubleshooting guides reference the circuit numbers shown in the schematic. DDC suggests including a prefix or suffix with the DDC circuit numbers when conflicts exist.

3.11.2 GENERAL WIRE

All wires used in conjunction with the DDEC must meet the following criteria:

NOTICE:
DDC does not recommend using any type of terminal lubricant or grease compounds. These products may cause dirt or other harmful substances to be retained in the connector. DDC has not tested these products and cannot stand behind their use.

NOTICE:
Insulation must be free of nicks.



Criteria: Wires

Tape, conduit, loom or a combination thereof must be used to protect the wires. Refer to sections 3.12 and 3.13.

All wires must be annealed copper wire (not aluminum).

All wires must comply with SAE J1128.

All wires must be insulated with cross-link polyethylene (XLPE) such as GXL, or any self-extinguishing insulation having a minimum rating of -40°C (-40°F) to 125°C (257°F).

3.11.3 WIRING FOR VIH-TO-ECM CONNECTOR

NOTICE:

Wires greater than 2.97 mm (.117 in.) must not be used in the VIH-to-ECM connector, as irreparable damage to the seal may result.

NOTICE:

Failure to use the proper cable diameter may result in the inability to obtain proper terminal installation.

The VIH 30-pin connector is designed to accept 18 gage (0.75 - 0.80 mm²) standard wall thickness cable, only.

3.11.4 RETURN POWER (GROUND) CIRCUITS

Switch ground (circuit 953) must only be used to provide ground for DDEC components and must be sourced directly from the negative battery or bus bar terminal

NOTE:

This circuit can not be used to provide ground for non- DDEC IV OEM-supplied electronics.

3.11.5 DATA LINK CIRCUITS

Twisting of the following wire pairs a minimum of 12 turns per foot (305 mm), is required to minimize electromagnetic field coupling effects.

- Data link circuits 900 and 901 (SAE J1587)
- Data link circuits 800 and 801 (SAE J1922)

Circuits 900 (Data Link +) and 901 (Data Link -) are used as the J1587 communication link. These circuits also exist in the DDEC six-pin or nine-pin diagnostic connector for use with the DDR.

Circuits 800 (Data Link +) and 801 (Data Link-) as shown on the communications harness schematic are used as the SAE J1922 communication link.

Circuits 925 [CAN_H/J1939 (+)], 926 [CAN_L J1939 (-)] and 927 (CAN_SHLD/J1939 Shield) as shown on the communications harness schematic are used as the SAE J1939 communication link. See Figure 3-15.

3.11.6 POWER HARNESS WIRE RESISTANCE

Twelve gage wires are required at the power harness connector. The total resistance of any power harness wire from the ECM to the battery (or bus bar) can not exceed 50 m Ω . The characteristics for Teflon coated and GXL type wire gages are listed in Table 3-39.

SAE Wire Gage	Metric Gage #	Area mm ²	Resistance mΩ/m	Resistance mΩ/ft @ 20°C	Resistance mΩ/ft @ 120°C	Diameter mm
16	1	1.129	15.300	4.66	6.50	0.72
14	2	1.859	9.290	2.83	3.94	1.18
12	3	2.929	5.900	1.80	2.50	1.86
10	5	4.663	3.720	1.13	1.58	2.97
8	8	7.277	2.400	0.73	1.02	4.63

Table 3-39 Power Harness Wire Characteristics

3.11.7 PACKARD ELECTRIC TERMINAL INSTALLATION AND REMOVAL

The method of terminal installation and removal varies, depending on the terminal/connector design. Crimp techniques and harness dressing must also be performed in accordance with recommended procedures to assure waterproof connections.

NOTICE:
Terminals should not be soldered to the cable.

Crimp and Removal Tools

Crimp tools and connector removing tools can be purchased from Kent-Moore. The part and associated part numbers are listed in Table 3-40 below:

Connector	Tool	Kent-Moore P/N
Metri-Pack 150	Removing	J 35689-A
	Crimp	J 35123
Weather Pack	Removing	J 36400-5
Metri-Pack 280	Removing (18 AWG)	J 33095
	Crimp (18 AWG)	J 38125-12A
	Removing (12 AWG - Used for power harness)	J 33095
	Crimp (12 AWG - Used for power harness)	J 39848
Deutsch	Removing (12 AWG)	J 37451
	Removing (16-18 AWG)	J 34513-1
	Crimp	J 34182

Table 3-40 Crimp and Removal Tools

Kent-Moore

Phone: 1-800-345-2233

www.spxkentmoore.com

Push-to-Seat Terminal Installation Guidelines

The following guidelines apply to all push-to-seat terminals.

NOTICE:

If a separate seal is required, be sure to install the seal onto the wire before stripping the insulation.
--

NOTICE:

No more than one strand in a 16 strand wire may be cut or missing.
--

1. Position a seal on each terminal lead so 5.0 ± 0.5 mm ($.20 \pm .02$ in.) conductor and 1.0 ± 0.1 mm ($.05 \pm .005$ in.) cable protrudes past the seal after being stripped (see Figure 3-32).

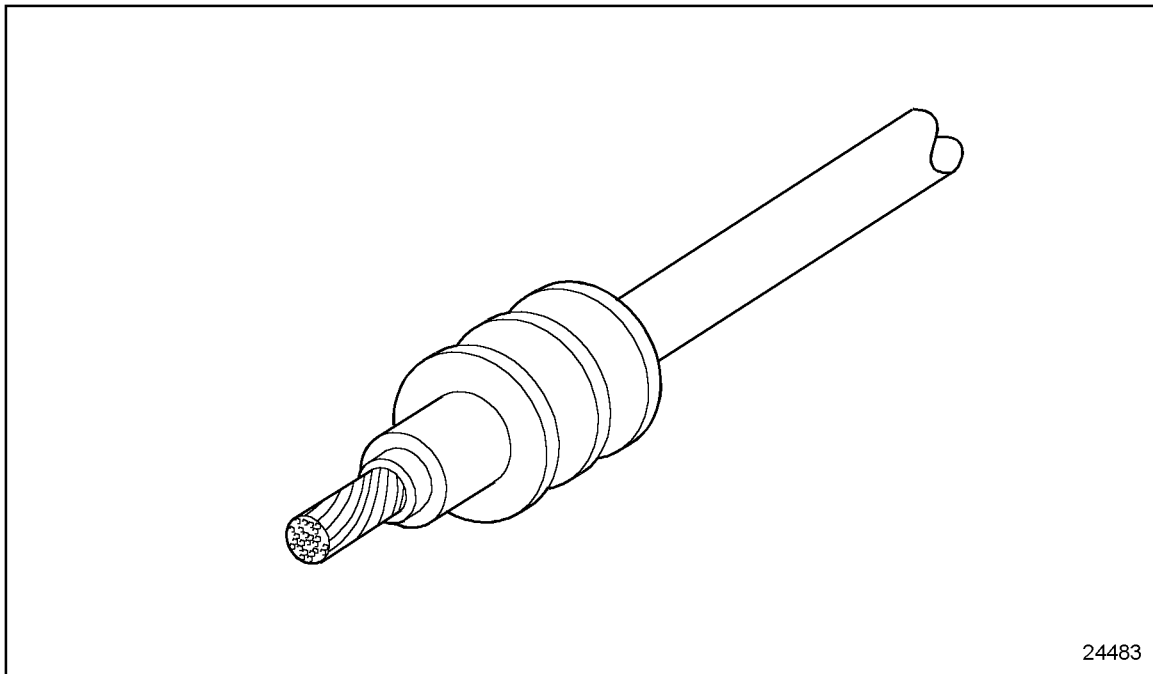

Figure 3-32 Seal Positioning

2. Remove the insulation from the end of the cable with J 35615 (or equivalent), exposing 5.0 ± 0.5 mm ($0.2 \pm .02$ in.) conductor (wire), a sufficient amount of wire to be crimped by the terminal core wings (see Figure 3-33).

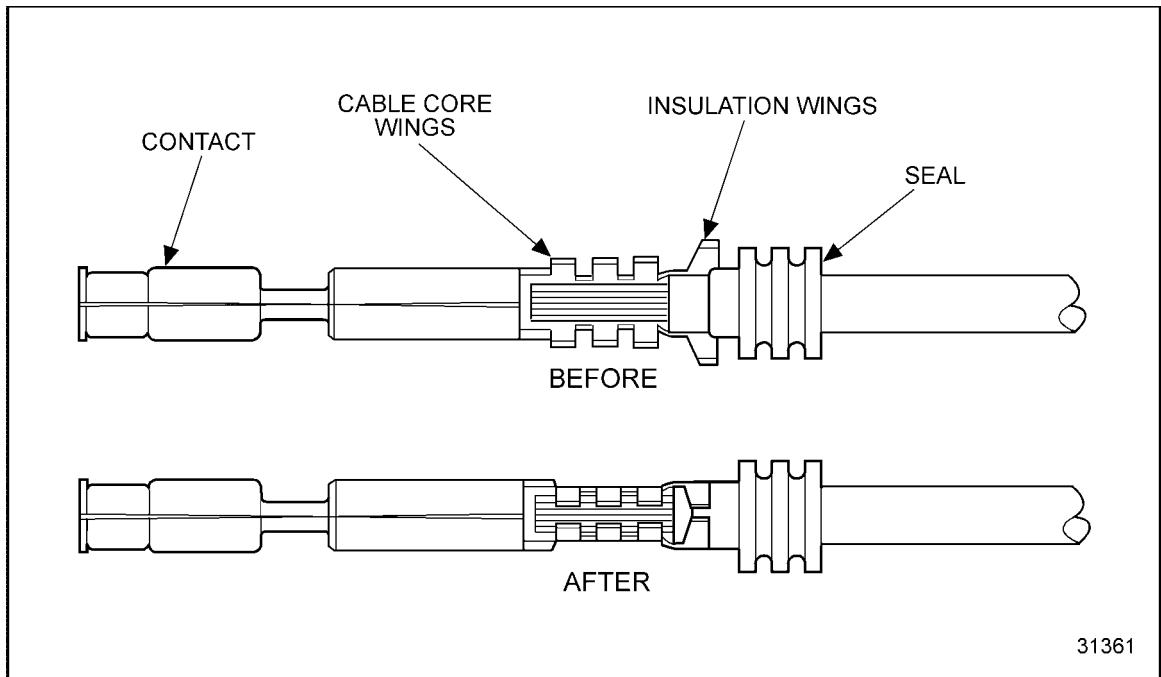

Figure 3-33 Terminal Installation (Shown with a Seal)

3. Insert the terminal into the locating hole of the crimping tool using the proper hole according to the gage and function of the cable to be used. See Figure 3-34.

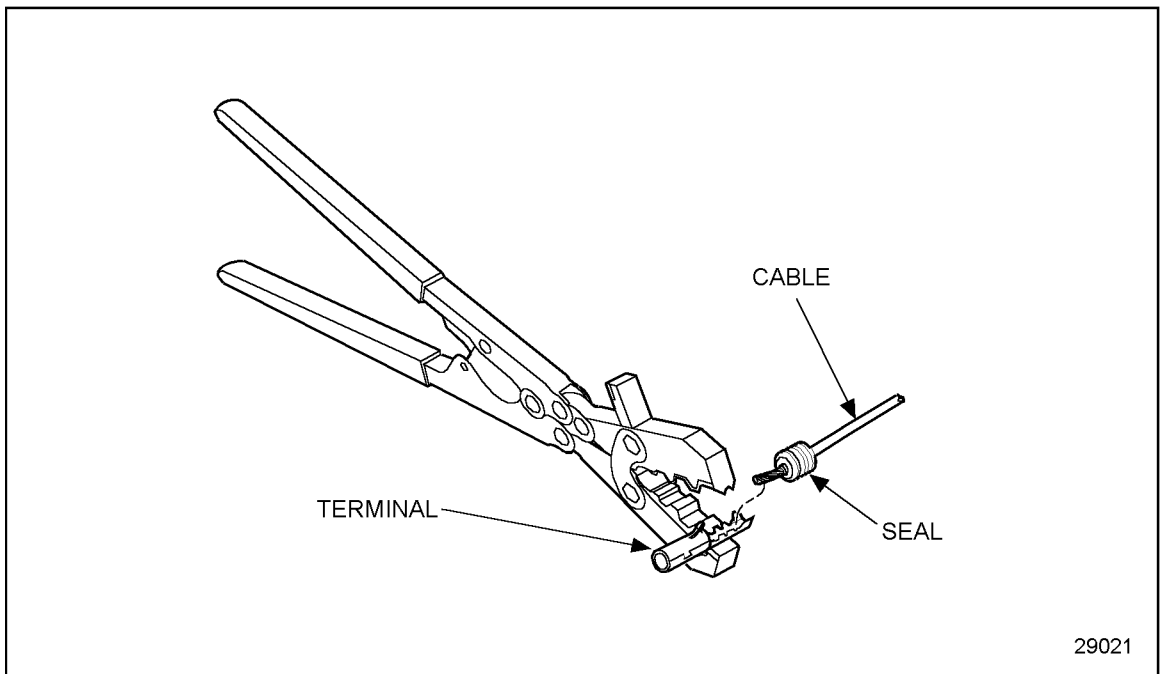

Figure 3-34 Terminal Position (Shown With a Seal)

4. Insert the cable in the terminal so the stripped portion is positioned in the cable core wings and the insulated portion of the cable is in the insulation wings (see Figure 3-34). Position the seal on the cable so the insulation wings grip the seal (see Figure 3-33).
5. Compress the handles of the crimping tool to crimp the core and insulation wings until the ratchet automatically releases.
6. To install the remaining terminals, repeat steps 3 and 4.

NOTE:

Release the crimping tool with the lock lever located between the handles, in case of jamming.

7. Gently tug on the terminal to make sure it is secure. The criteria listed in Table 3-41 must be met.

Wire Gage	Must Withstand Applied Load
14 AWG	45 lb (200 N)
16 AWG	27 lb (120 N)
18 AWG	20 lb (90 N)

Table 3-41 Applied Load Criteria for the Terminal

NOTICE:
Any terminal that is cracked or ruptured is unacceptable as malfunctions may occur.

8. Replace incorrectly installed and damaged terminals by cutting off the terminal just after the insulation wings.

9. Insert terminals into connector and push to seat (see Figure 3-35). Insert the secondary lock(s) to position and secure the assembly.

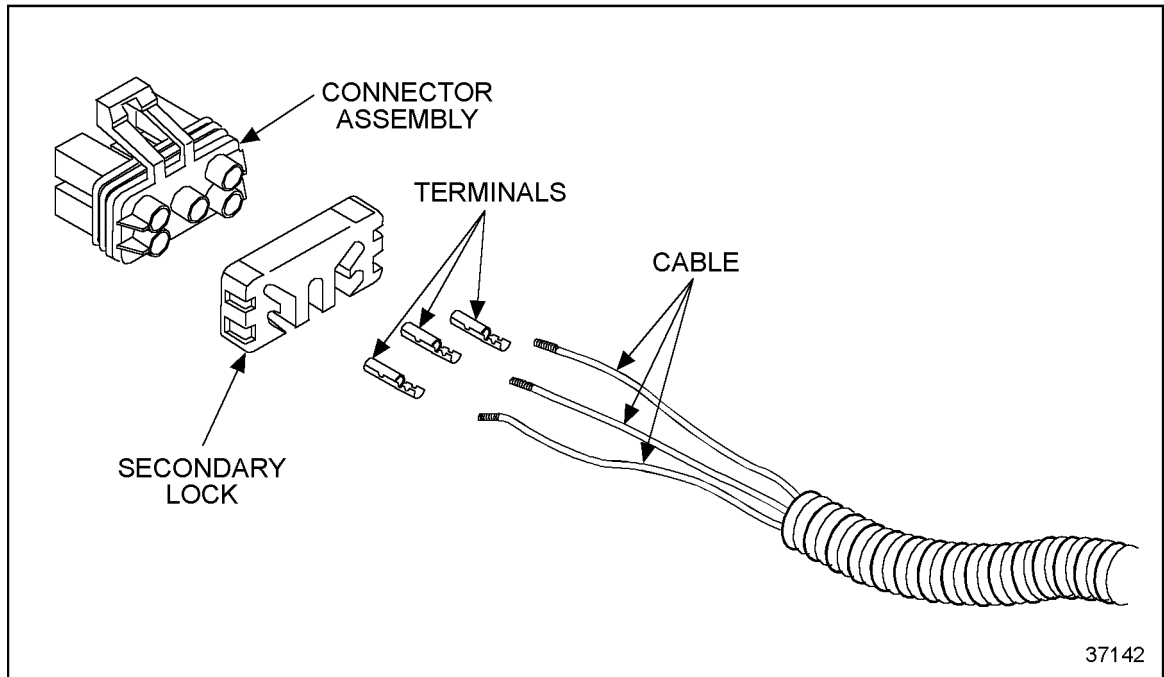

Figure 3-35 Typical Push-to-Seat Terminal Installation

Push-to-Seat Terminal Removal

One locking tang secures the push-to-seat terminals to the connector body. Use the following instructions for removing terminals from the connector body.

1. Grasp the cable to be removed and push the terminal to the forward position.
2. Insert the removal tool straight into the front of the connector cavity until it rests on the cavity shoulder. See Figure 3-36.

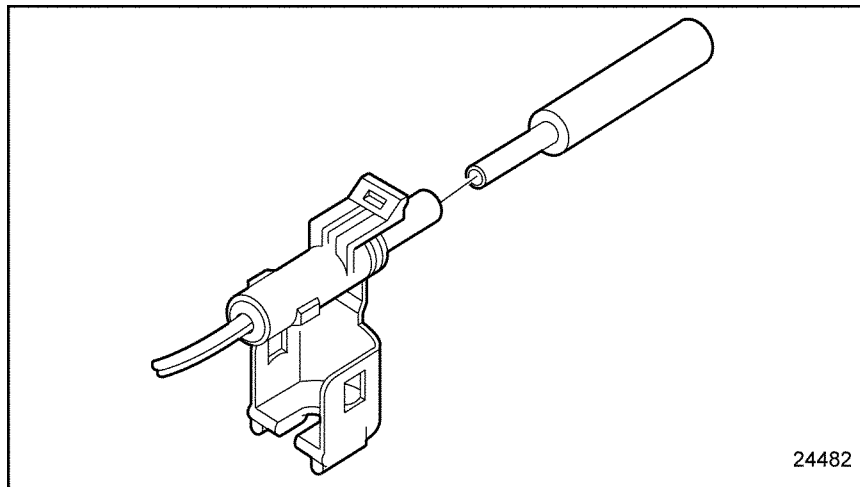

Figure 3-36 Removal Tool Procedure

3. Grasp the cable and push it forward through the connector cavity into the tool while holding the tool securely in place. The tool will depress the locking tangs of the terminal.
4. Pull the cable rearward (back through the connector).
5. Remove the tool from the connector cavity.
6. Cut the wire immediately behind the terminal crimp.
7. Follow the installation instructions for crimping on a replacement terminal.

Pull-to-Seat Terminal Installation Guidelines

The following guidelines apply to all pull-to-seat terminals.

Use the following instructions for pull-to-seat terminal installation without a seal:

1. Insert the wire through the appropriate connector hole/cavity (see Figure 3-37).

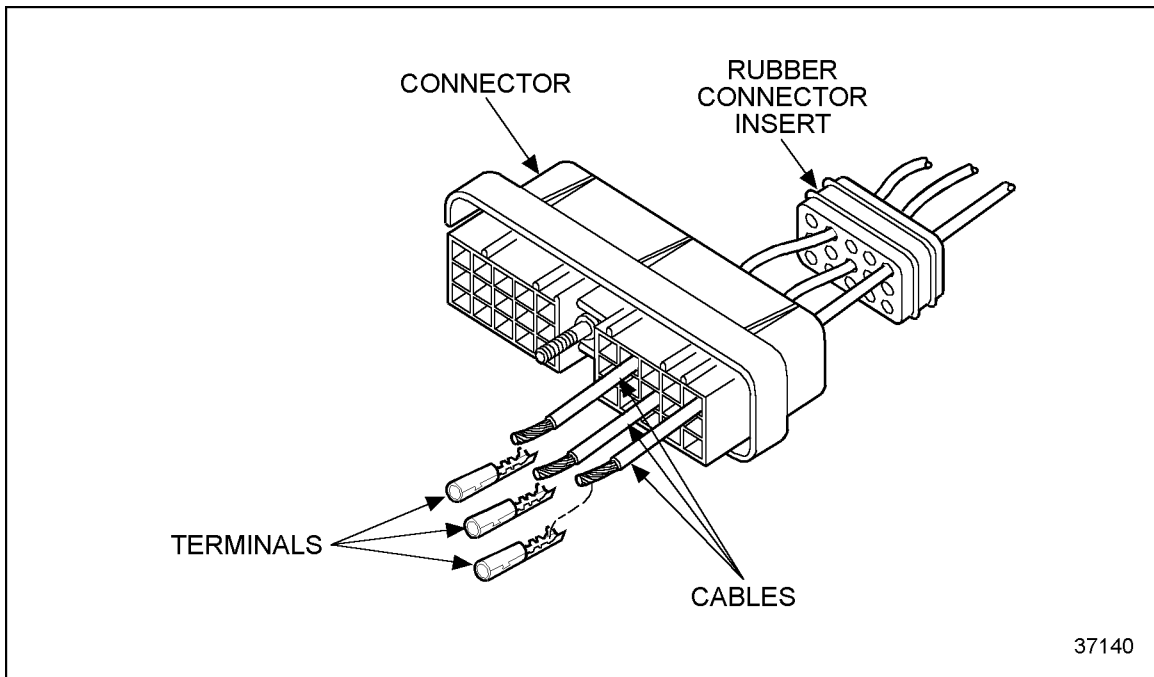

Figure 3-37 Wire Inserted Through the Connector

2. Remove the insulation from the end of the cable, exposing a sufficient amount of core leads to be crimped by the terminal core wings (see Figure 3-37).
3. Insert the terminal into the locating hole of the crimping tool using the proper hole according to the gage of the cable to be used (see Figure 3-38).

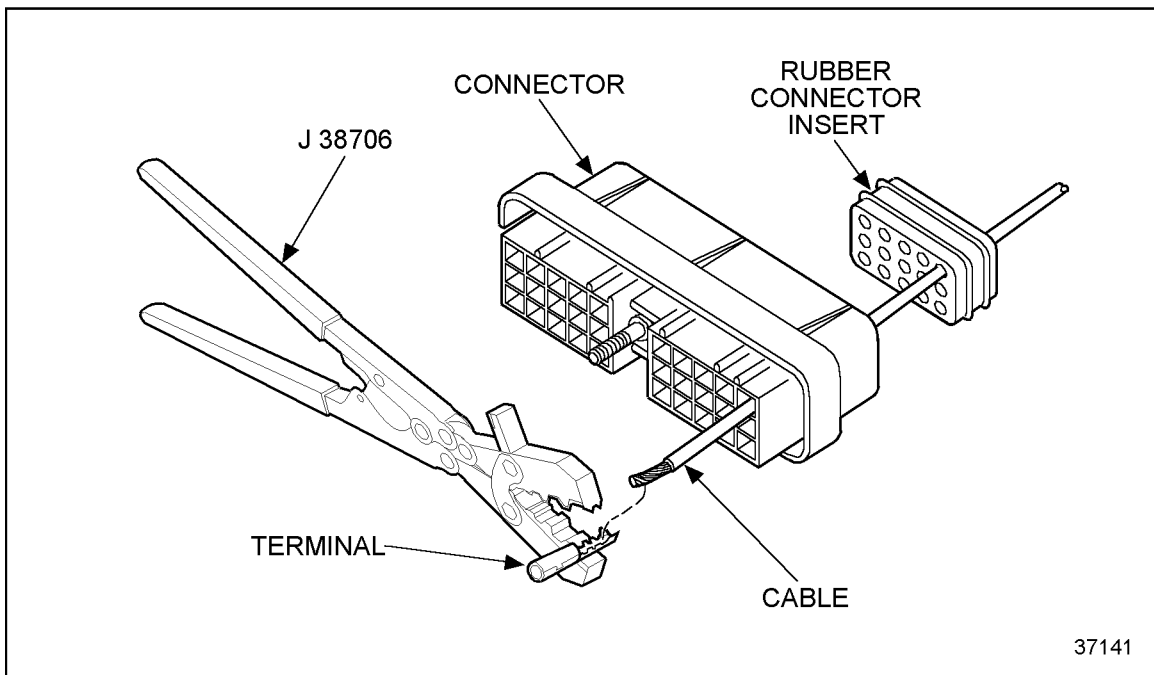

Figure 3-38 Typical Terminal Position

4. Insert the cable into the terminal so the stripped portion is positioned in the cable core wings and the insulated portion of the cable is in the insulation wings (see Figure 3-39).

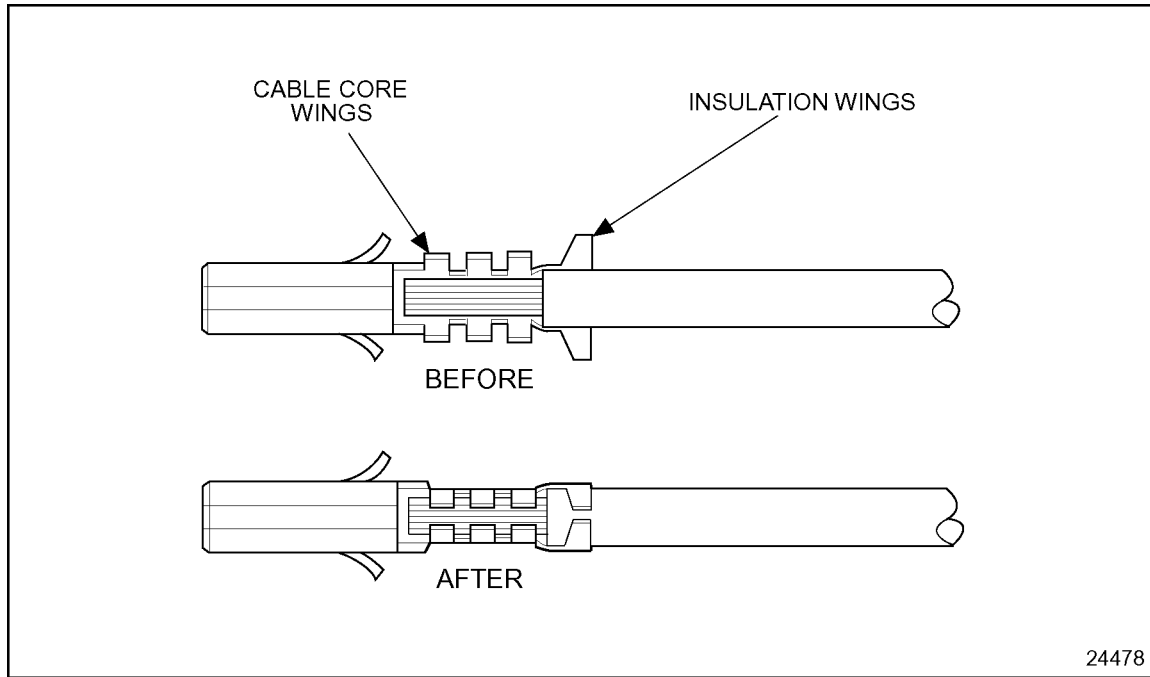

Figure 3-39 Typical Terminal Installation

5. Compress the handles of the crimping tool to crimp the core wing until the ratchet automatically releases.
6. Repeat steps 3, 4, and 5.

NOTE:

Release the crimping tool with the lock lever located between the handles, in case of jamming.

7. Gently tug on the terminal to make sure it is secure. The criteria listed in Table 3-42 must be met.

Wire Gage	Must Withstand Applied Load
14 AWG	45 lb (200 N)
16 AWG	27 lb (120 N)
18 AWG	20 lb (90 N)

Table 3-42 Applied Load Criteria for the Terminal

NOTICE:

Any terminal that is cracked or ruptured is unacceptable as malfunctions may occur.

8. Replace incorrectly installed and damaged terminals by cutting off the terminal just after the insulation wings.

Pull-to-seat Terminal Removal

A tang on the terminal locks into a tab molded into the plastic connector to retain the cable assembly. Remove terminals using the following instructions:

1. Insert the removal tool into the cavity of the connector, placing the tip of the tool between the locking tang of the terminal and the wall of the cavity.
2. Depress the tang of the terminal to release it from the connector.
3. Push the cable forward through the terminal until the complete crimp is exposed.
4. Cut the cable immediately behind the damaged terminal to repair it.
5. Follow the installation instructions for crimping the terminal and inserting it into the connector.

3.11.8 FCI APEX TERMINAL INSTALLATION AND REMOVAL

The following sections cover FCI APEX male and female terminal installation and removal.

FCI Apex Male Terminal Installation

Install the FCI APEX male terminal as follows:

1. Determine if the connector is new or used.
 - [a] If the connector is new, the red Terminal Assurance Position (TPA) is in an unlocked position so go to step 2.
 - [b] If the connector is used, pull the TPA out (see Figure 3-40).
2. Insert the crimped terminal into the connector until it clicks (see Figure 3-40). The orientation of the terminal is not critical.

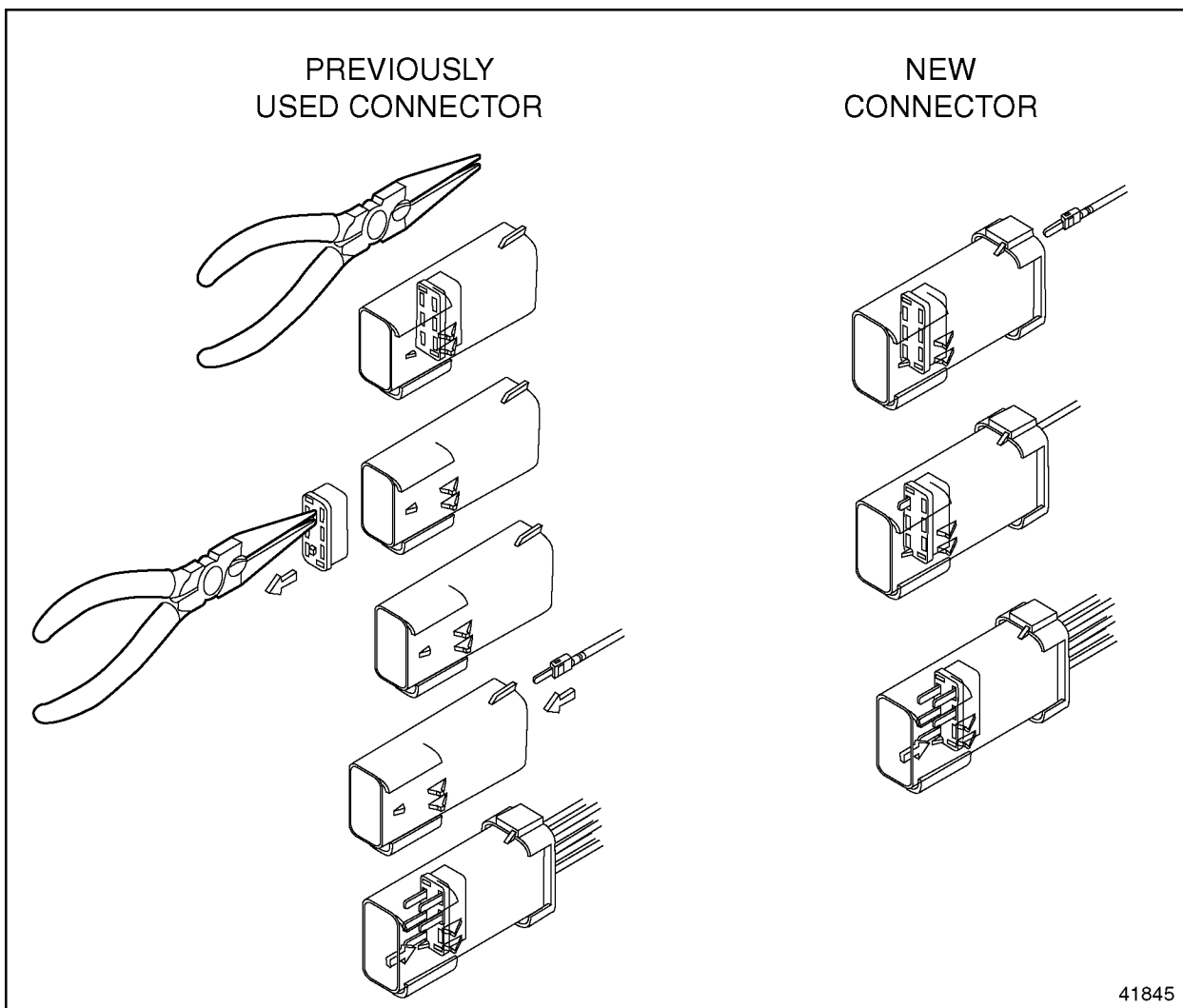

Figure 3-40 Installing the FCI Male Terminal

3. Push the TPA into the locked (fully seated) position.

NOTE:

The TPAs will self lock when the connectors are mated.

FCI Apex Male Terminal Removal

Remove the terminal as follows:

1. Using pliers pull out the red Terminal Position Assurance (TPA) (see Figure 3-41).

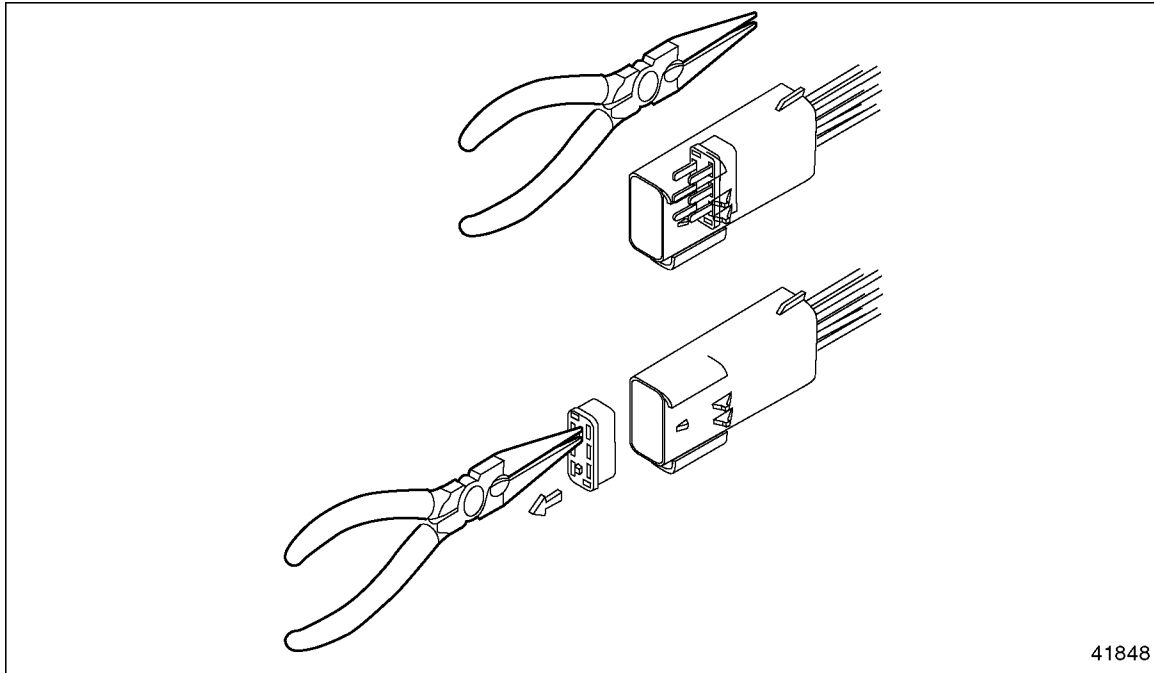

Figure 3-41 Removing the Terminal

- Using a FCI APEX repair tool (P/N: 54900002) or a #2 jeweler's screwdriver, press back the terminal locking tang (see Figure 3-42).

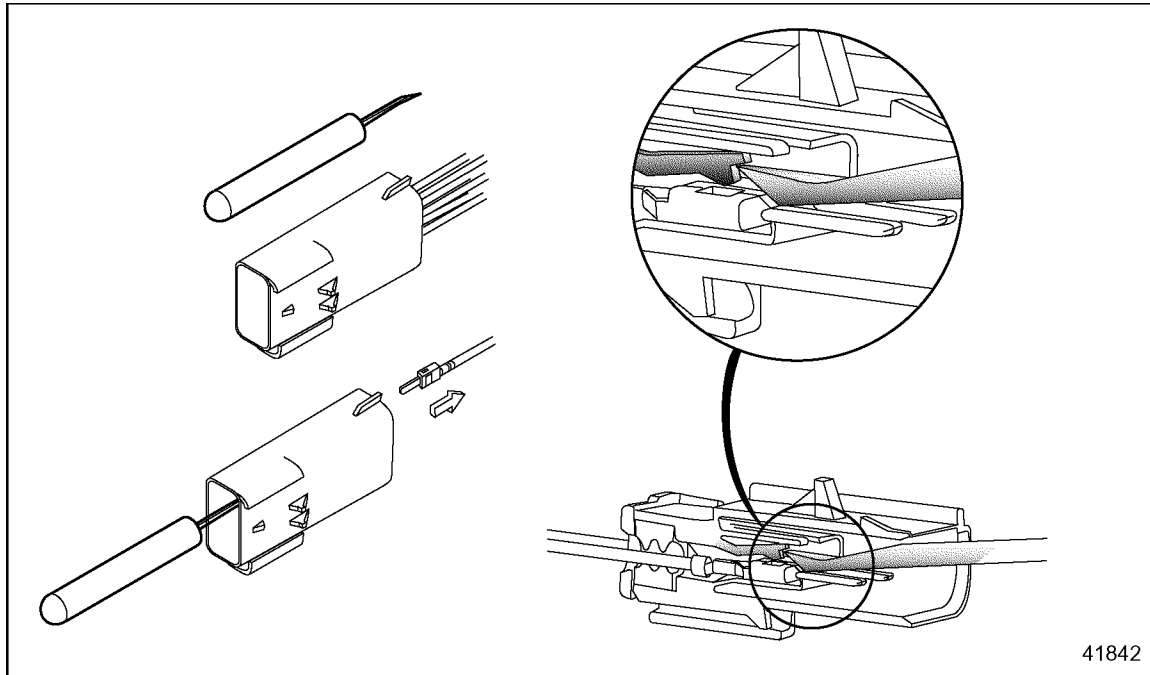

Figure 3-42 Pressing the Locking Tang

- Pull the cable back through the connector (see Figure 3-41).

FCI Apex Female Terminal Installation

Install the terminal as follows:

1. Determine if the connector is new or used.
 - [a] If the connector is new, the blue Terminal Assurance Position (TPA) is in an unlocked position so go to 2.
 - [b] If the connector is used, pull the TPA out (see Figure 3-43).
2. Insert the crimped terminal into the connector until it clicks (see Figure 3-43).

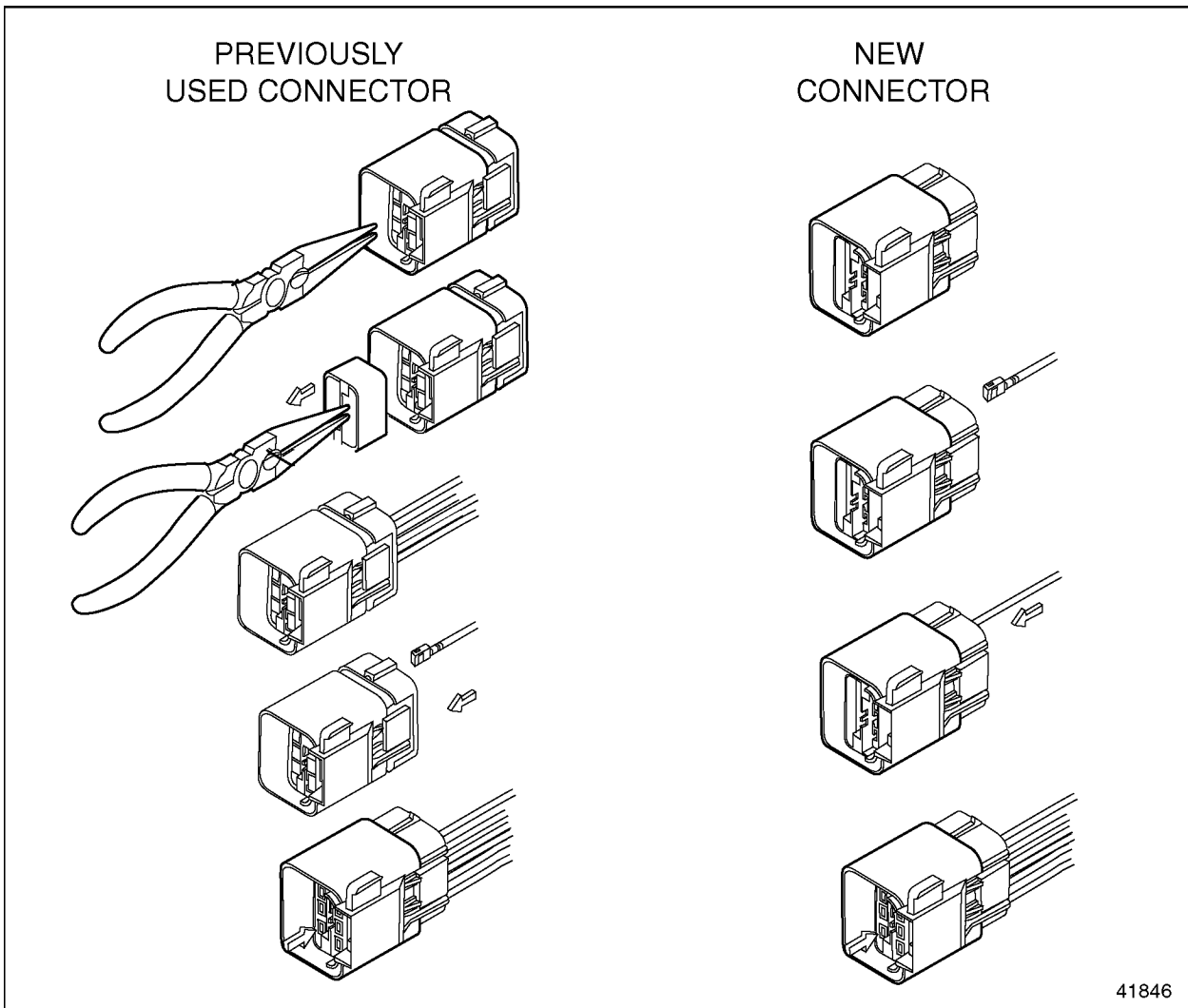

Figure 3-43 Installing the Terminal

3. Push the TPA into the locked (fully seated) position.

NOTE:

The TPAs will self lock when the connectors are mated.

FCI Apex Female Terminal Removal

Remove the terminal as follows:

1. Using pliers pull out the blue Terminal Position Assurance (TPA) that is located inside the connector (see Figure 3-44).

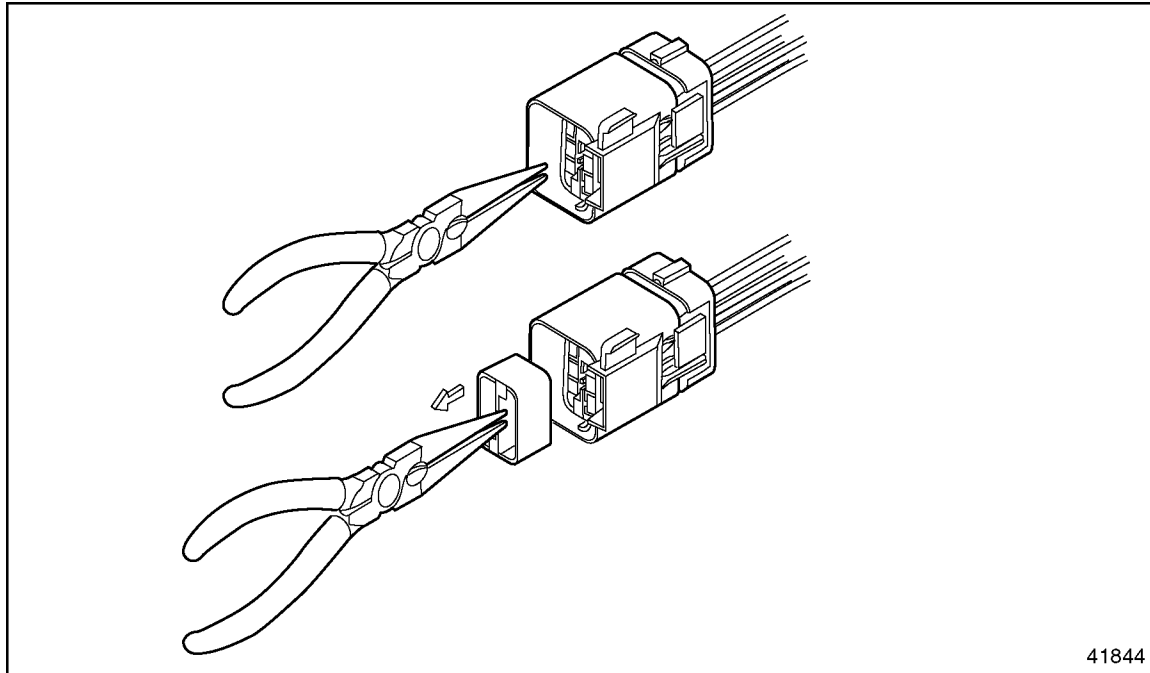

Figure 3-44 Removing the Terminal

- Using a FCI APEX repair tool (P/N: 54900002) or a #2 jeweler's screwdriver, press back the terminal locking tang (see Figure 3-45).

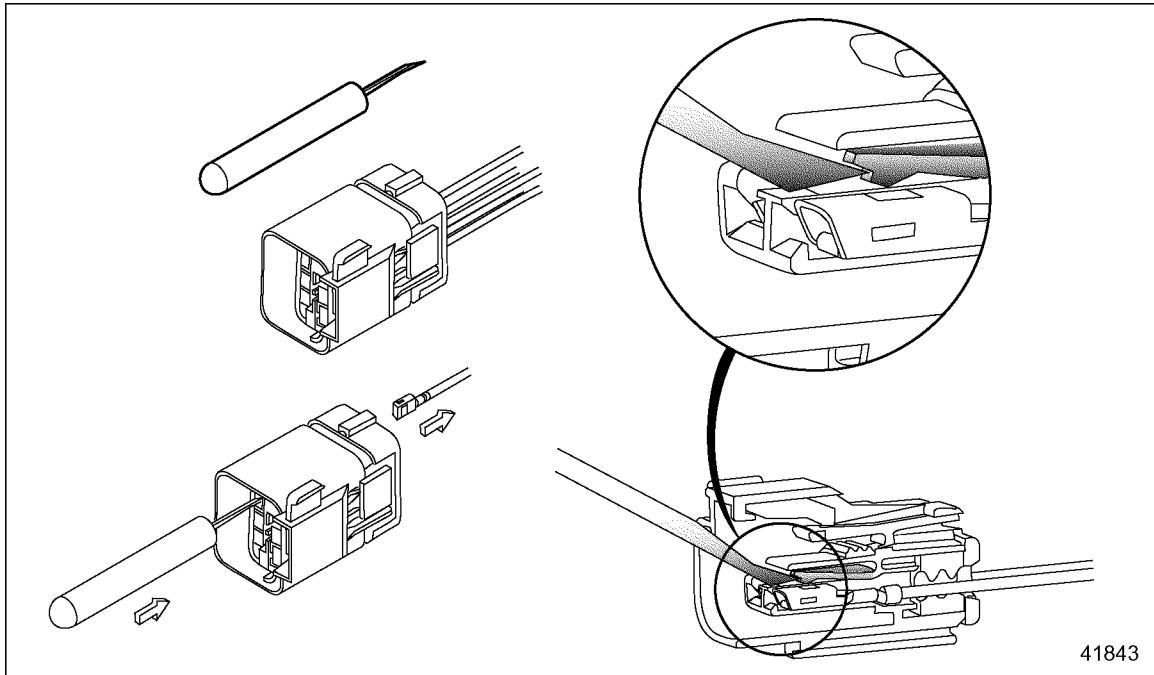

Figure 3-45 Pressing the Locking Tang

- Pull the cable back through the connector (see Figure 3-44).

3.11.9 DEUTSCH TERMINAL INSTALLATION AND REMOVAL

The method of terminal installation and removal varies. The following sections cover Deutsch terminal installation and removal.

Deutsch Terminal Installation Guidelines

Deutsch connectors have cable seals molded into the connector. These connectors are push-to-seat connectors with cylindrical terminals. The diagnostic connector terminals are gold plated for clarity.

NOTICE:
Improper selection and use of crimp tools have varying adverse effects on crimp geometry and effectiveness. Proper installation of terminals require specialized tools. Do not attempt to use alternative tools.

The crimp tool to use in Deutsch terminal installation is J 34182 (Kent-Moore part number).

NOTICE:
Terminal crimps must be made with the Deutsch crimp tool P/N: HDT-48-00 to assure gas tight connections.

NOTICE:
If a separate seal is required, be sure to install the seal onto the wire before stripping the insulation.

Use the following instructions for installing Deutsch terminals:

1. Strip approximately .25 inch (6 mm) of insulation from the cable.
2. Remove the lock clip, raise the wire gage selector, and rotate the knob to the number matching the gage wire that is being used.
3. Lower the selector and insert the lock clip.
4. Position the contact so that the crimp barrel is 1/32 of an inch above the four indenters. See Figure 3-46. Crimp the cable.

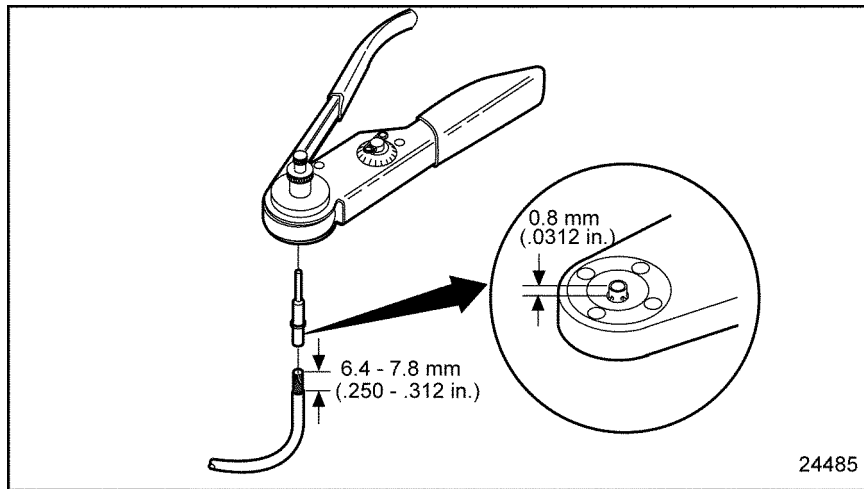

Figure 3-46 Setting Wire Gage Selector and Positioning the Contact

5. Grasp the contact approximately one inch behind the contact crimp barrel. Hold the connector with the rear grommet facing you. See Figure 3-47.

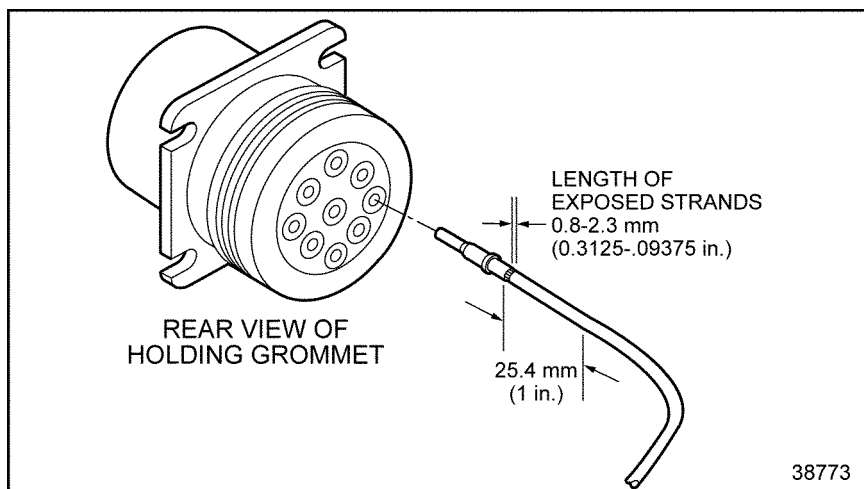

Figure 3-47 Pushing Contact Into Grommet

6. Push the contact into the grommet until a positive stop is felt. See Figure 3-47. A slight tug will confirm that it is properly locked into place. See Figure 3-48.

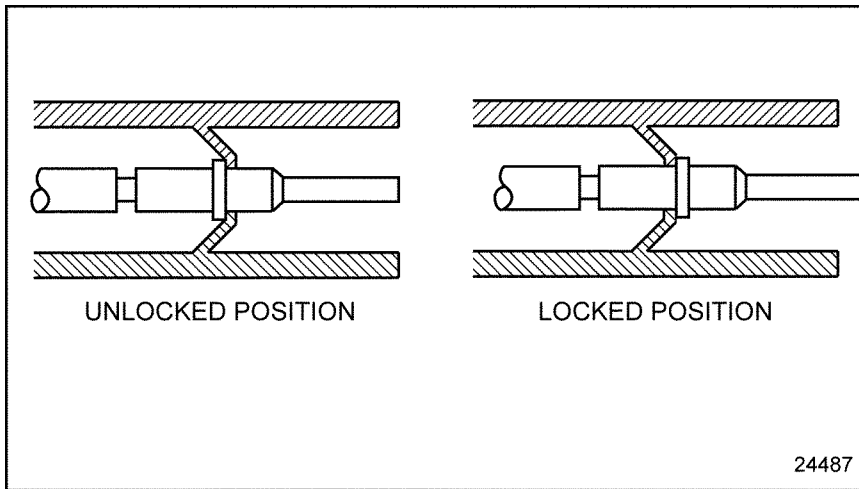

Figure 3-48 Locking Terminal Into Connector

Deutsch Terminal Removal

The appropriate size removal tool should be used when removing cables from connectors. The proper removal tools are listed in Table 3-43.

Tool	Kent-Moore Part Number
Removing (12 AWG)	J 37451
Removing (16-18 AWG)	J 34513-1

Table 3-43 Removal Tools for Deutsch Terminals

Remove Deutsch terminals as follows:

1. With the rear insert toward you, snap the appropriate size remover tool over the cable of contact to be removed. See Figure 3-49.

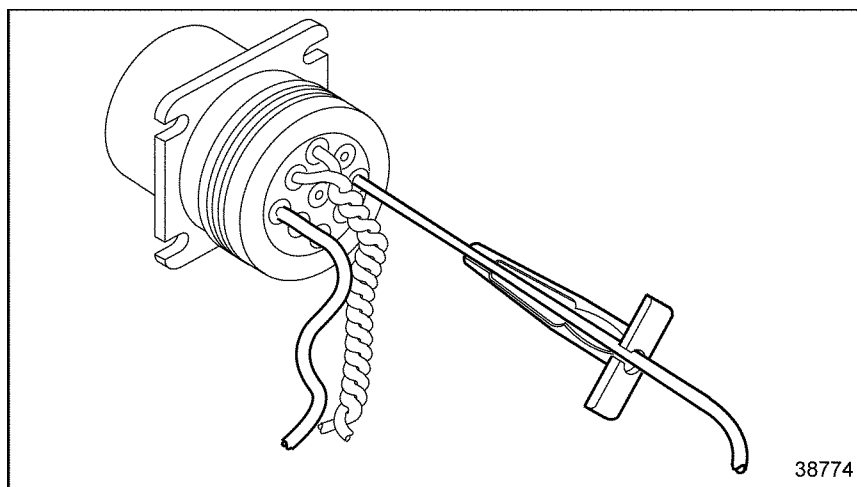

Figure 3-49 Removal Tool Position

2. Slide the tool along the cable into the insert cavity until it engages and resistance is felt. Do not twist or insert tool at an angle. See Figure 3-50.

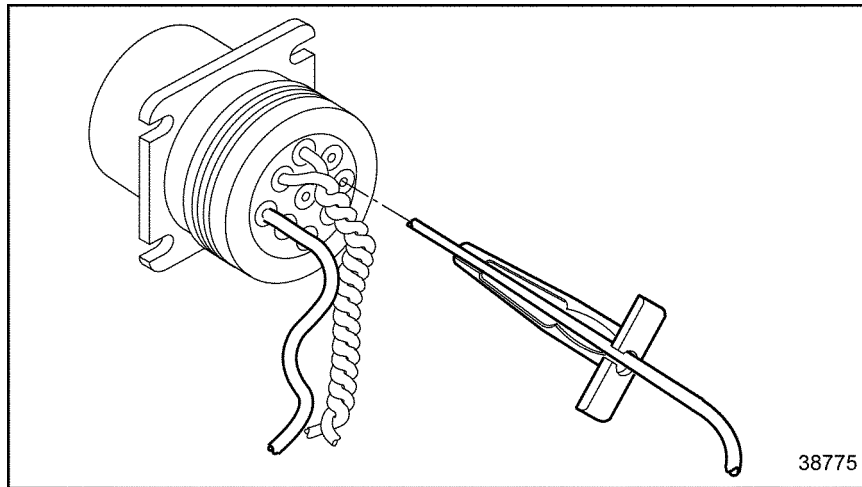

Figure 3-50 Removal Tool Insertion

3. Pull contact cable assembly out of the connector. Keep reverse tension on the cable and forward tension on the tool.

3.11.10 SPLICING GUIDELINES

The following are guidelines which may be used for splices. The selection of crimpers and splice connectors is optional. Select a high quality crimper equivalent to the Kent-Moore tool, J 38706, and commercially available splice clips.

The recommended technique for splicing and repairing circuits (other than power and ignition circuits) is a clipped and soldered splice. Alternatively, any method that produces a high quality, tight (mechanically and electronically sound) splice with durable insulation is considered to be acceptable.

Clipped and Soldered Splicing Method

The tools required are listed in Table 3-44.

Tool	Part Number
Heat Gun	--
Sn 60 solder with rosin core flux	--
Wire Stripper	Kent-Moore J 35615 or equivalent
Splice Clips (commercially available)	Wire size dependent
Heat Shrink Tubing	Raychem HTAT or equivalent

Table 3-44 Recommended Splicing Tools

**Criteria: Splicing Straight Leads**

No more than one strand in a 16 strand wire may be cut or missing.

Use Sn 60 solder with rosin core flux.

The exposed wire must be clean before the splice is soldered.

Soldering splice connectors is optional. To solder splice connectors:

1. Position the leads, so one overlaps the other. See Figure 3-51.

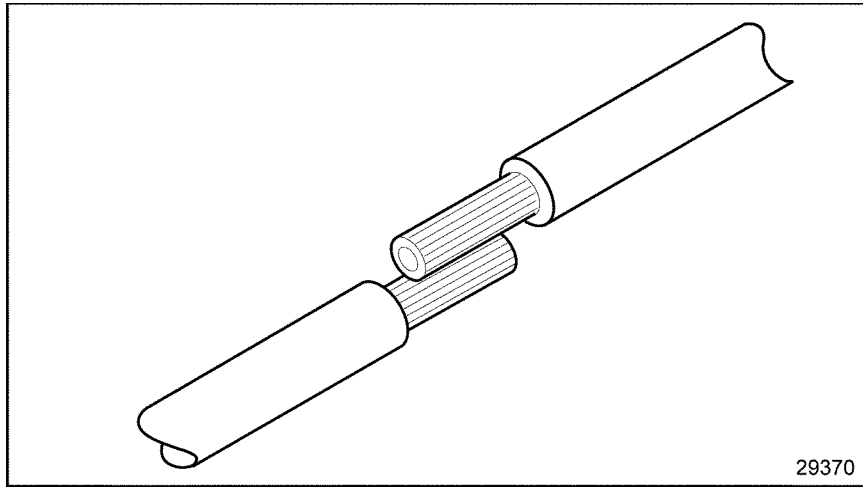

Figure 3-51 Positioning the Leads

2. Secure the leads with a commercially available clip and hand tool. See Figure 3-52.

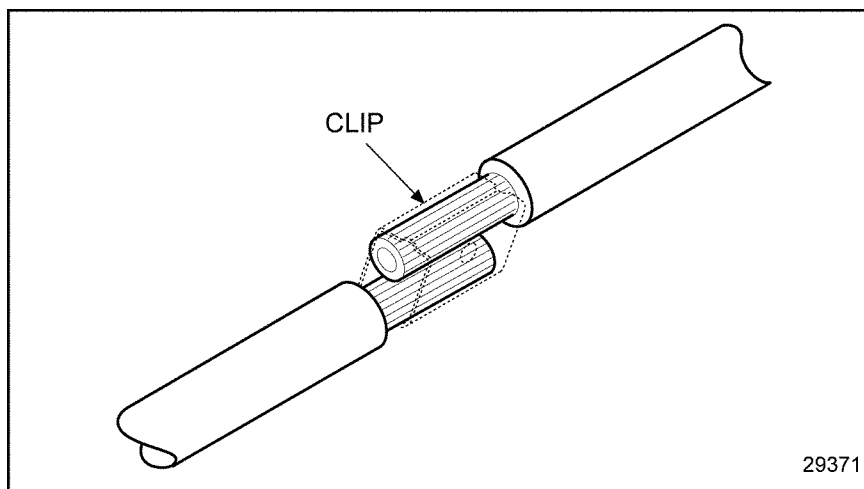

Figure 3-52 Securing the Leads With a Clip

3. Use a suitable electronic soldering iron to heat the wires. Apply the solder to the heated wire and clip (not to the soldering iron) allowing sufficient solder flow into the splice joint.
4. Pull on wire to assure crimping and soldering integrity. The criteria listed in Table 3-45 must be met.

Wire Gage	Must Withstand Applied Load
14 AWG	45 lb (200 N)
16 AWG	27 lb (120 N)
18 AWG	20 lb (90 N)

Table 3-45 Applied Load Criteria for Terminals

5. Loop the lead back over the spliced joint and tape. See Figure 3-53.

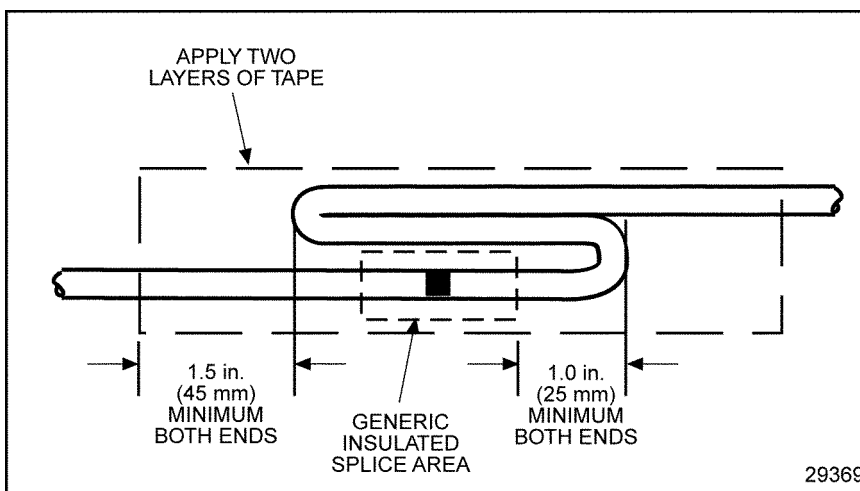

Figure 3-53 Recommended Strain Relief of Spliced Joint

Splicing and Repairing Straight Leads-Alternate Method 1

The tools required are listed in Table 3-46.

Tool	Part Number
Heat Gun	--
Wire Stripper	Kent-Moore J 35615 or equivalent
Splice Clips (commercially available)	Wire size dependent
Heat Shrink Tubing	Raychem HTAT or equivalent
Terminal Crimper for Metri-Pack 280 (12 AWG)	Kent-Moore J 38125-6
Terminal Crimper for Metri-Pack 280 (18 AWG)	Kent-Moore J 39848
Terminal Crimper for Weather Pack	Kent-Moore J 35606
Terminal Crimper for Deutsch	Kent-Moore J 34182
Terminal Crimper for Metri-Pack 150	Kent-Moore J 35123

Table 3-46 Recommended Splicing Tools



Criteria: Splicing Straight Leads

No more than one strand in a 16 strand wire may be cut or missing.

The recommended method to splice straight leads follows:

1. Locate broken wire.
2. Remove insulation as required; be sure exposed wire is clean and not corroded.
3. Insert one wire into the splice clip until it butts against the clip. Stop and crimp (see Figure 3-54, A).
4. Insert the other wire into the splice clip until it butts against the clip stop (see Figure 3-54, B).

NOTICE:

Any terminal that is cracked or ruptured is unacceptable as malfunctions may occur.

5. Visually inspect the splice clip for cracks, rupture, or other crimping damage. Remove and replace damaged clips before proceeding.
6. Pull on wire to ensure the splice integrity. The criteria listed in Table 3-47 must be met.

Wire Gage	Must Withstand Applied Load
14 AWG	45 lb (200 N)
16 AWG	27 lb (120 N)
18 AWG	20 lb (90 N)

Table 3-47 Applied Load Criteria for Terminals

7. Shrink the splice clip insulative casing with a heat gun to seal the splice (see Figure 3-54, C).

NOTICE:

Splices may not be closer than 12 in. (.3 m) apart to avoid degradation in circuit performance. Replace wire to avoid having splices closer than 12 in. (.3 m) apart.

8. Loop the lead back over the spliced joint and tape. See Figure 3-53.

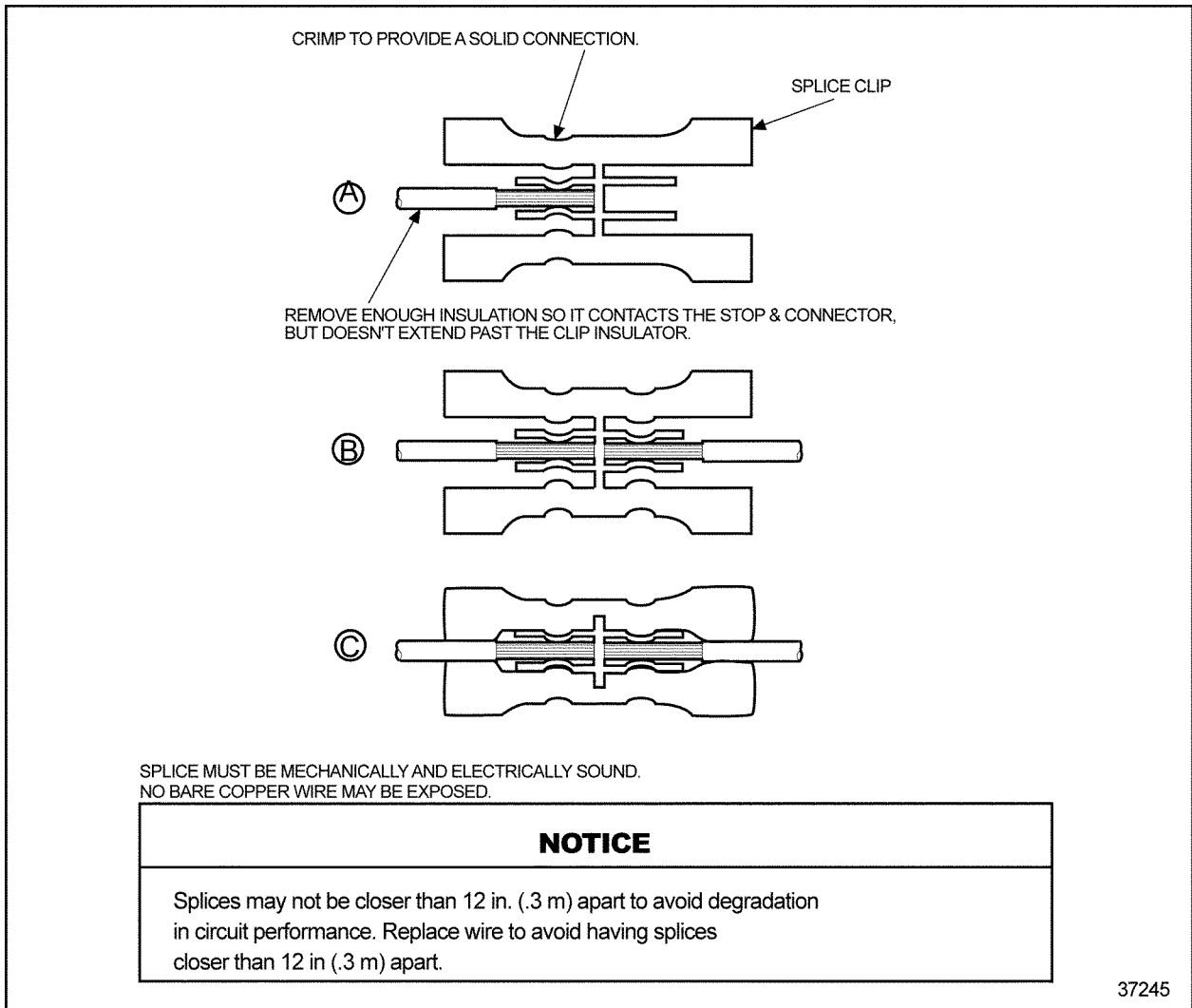

Figure 3-54 Splicing Straight Leads - Alternate Method 1

Splicing and Repairing Straight Leads - Alternate Method 2

This method is not allowed or recommended for power or ignition circuits. The tools required are listed in Table 3-48.

Tool	Part Number
Heat Gun	--
Wire Stripper	Kent-Moore J 35615 or equivalent
Splice Clips (commercially available)	Wire size dependent
Heat Shrink Tubing	Raychem HTAT or equivalent
Terminal Crimper for Metri-Pack 280 (12 AWG)	Kent-Moore J 38125-6
Terminal Crimper for Metri-Pack 280 (18 AWG)	Kent-Moore J 39848
Terminal Crimper for Weather Pack	Kent-Moore J 35606
Terminal Crimper for Deutsch	Kent-Moore J 34182
Terminal Crimper for Metri-Pack 150	Kent-Moore J 35123

Table 3-48 Recommended Splicing Tools



Criteria: Splicing Straight Leads

No more than one strand in a 16 strand wire may be cut or missing.

An acceptable option for splicing straight leads is:

1. Locate broken wire.
2. Remove insulation as required; be sure exposed wire is clean and not corroded.
3. Slide a sleeve of glue lined, shrink tubing (Raychem HTAT or equivalent) long enough to cover the splice clip on the wire and overlap the wire insulation, about .25 in. (6 mm) on both sides (see Figure 3-55, A).
4. Insert one wire into splice clip until it butts against the splice clip. Stop and crimp (see Figure 3-55, B).
5. Insert the remaining wires into the splice clip one at a time until each butts against the splice clip; stop and crimp (see Figure 3-55, B).

NOTICE:

Any terminal that is cracked or ruptured is unacceptable as malfunctions may occur.

6. Visually inspect the terminal for cracks, rupture, or other crimping damage. Remove and replace damaged terminal before proceeding.
7. Slide the shrink tubing over the crimped splice clip (see Figure 3-55, C).
8. Shrink tubing with a heat gun to seal the splice (see Figure 3-55, D).

NOTICE:

A minimum of two layers of heat shrink tubing must be applied to splices that have more than one lead in or out.

9. Loop the lead back over the spliced joint and tape. See Figure 3-53.

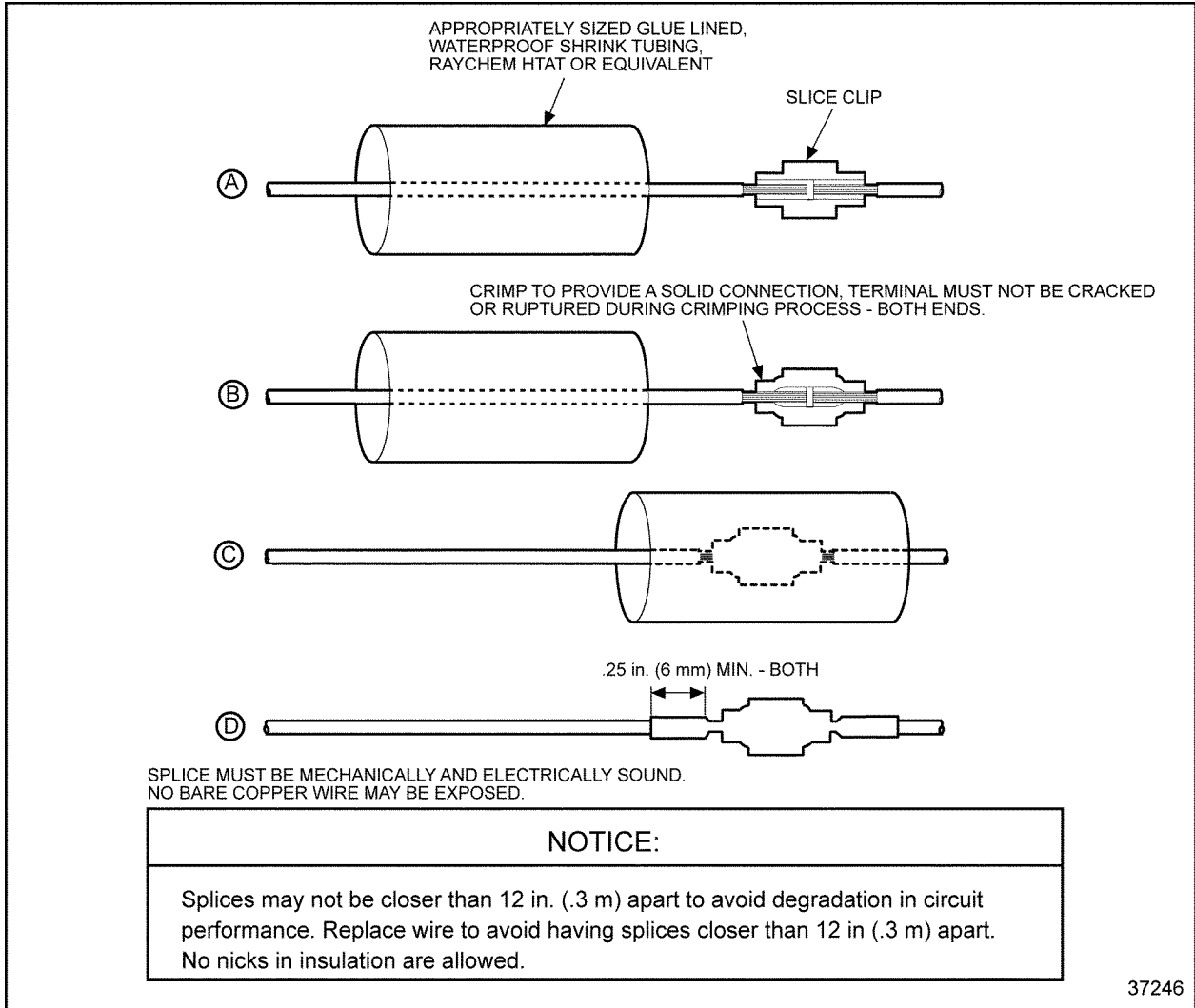

Figure 3-55 Splicing Straight Leads - Alternate Method 2

Shrink Wrap

Shrink wrap is required when splicing non insulated connections. Raychem HTAT or any equivalent heat shrink dual wall epoxy encapsulating adhesive polyolefin is required. Shrink wrap must extend at least .25 in. (6 mm) over wire insulation past splice in both directions.

Alpha Wire Corporation

711 Lidgerwood Ave
P.O. Box 711
Elizabeth, New Jersey 07207-0711
1-800-52ALPHA
www.alphawire.com

Tyco Electronics Corporation

Raychem Cable Identification and Protection
300 Constitution Drive
Menlo Park, CA 94025
Phone: 1-800-926-2425
www.raychem.com

To heat shrink wrap a splice:

NOTICE:

The heat shrink wrap must overlap the wire insulation about .25 in. (6 mm) on both sides of the splice.

1. Select the correct diameter to allow a tight wrap when heated.
2. Heat the shrink wrap with a heat gun; do not concentrate the heat in one location, but apply the heat over the entire length of shrink wrap until the joint is complete.
3. Repeat step 2 to apply a second layer of protection (if required by splicing guidelines).

Staggering Wire Splices

Position spliced wires properly as follows:

NOTICE:

You must stagger positions to prevent a large bulge in the harness and to prevent the wires from chafing against each other.

1. Stagger the position of each splice (see Figure 3-56) so there is at least a 2.5 in. (65 mm) separation between splices.

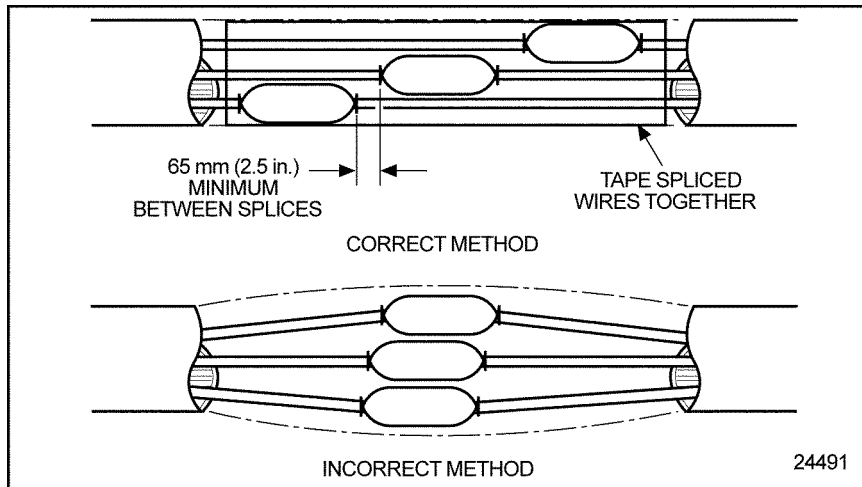

Figure 3-56 The Correct and Incorrect Method of Staggering Multiple Splices

NOTICE:

A minimum of two layers of heat shrink tubing extending .25 in. (6 mm) past the splice must be used to complete the splice.

2. Heat shrink a minimum of two layers of heat shrink tubing.
3. Tape the spliced wires to each other. Refer to section 3.12.

THIS PAGE INTENTIONALLY LEFT BLANK

3.12 CONDUIT AND LOOM

Conduit must be used to protect the harness cable and cable splices.

NOTICE:

The conduit must not cover any connectors, switches, relays, fuses, or sensors.

The following guidelines should be used when designing a harness:

NOTICE:

Wires should be sized and cut to near equal length prior to installing conduit.

- The distance between the back of the connector or other listed devices to the end of the conduit should not exceed:
 - 1.0 in. (25 mm) for a single connector/device
 - 3 in. (75 mm) for multiple connectors/devices
- All cable breakouts and conduit ends must be secured in place with conduit outlet rings or tape.



Criteria: Conduit and Loom

Due to the wide variety of operating conditions and environments, it is the responsibility of the OEM to select a conduit that will survive the conditions of the specific applications. Flame retardant convoluted polypropylene conduit or equivalent may be used for most installations. Heat retardant nylon conduit or oil, water, acid, fire, and abrasion resistant non-metallic loom conforming to SAE J562A* is also acceptable. The diameter of conduit should be selected based on the number of wires being protected.

* If non-metallic loom is used, secure the ends with tightly wrapped nylon straps to prevent unraveling.

Conduit should cover the wires without binding and without being excessively large.

THIS PAGE INTENTIONALLY LEFT BLANK

3.13 TAPE AND TAPING

Tape must be used when conduit is utilized. Be sure to follow the tape manufacturers' guidelines. The harness manufacturer may use tape under the harness covering (conduit or loom) to facilitate harness building. Tape must be tightly wrapped at all conduit interconnections with a minimum of two layers (refer to section 3.12). Be sure to firmly secure the start and finish ends of tape.



Criteria: Tape

NOTICE:
Black vinyl electrical tape should not be used in applications where the temperature exceeds 176°F (80°C).

In applications where the temperature doesn't exceed 176°F (80°C), black vinyl electrical tape that is flame retardant and weather resistant may be used.

In applications where temperature exceeds 176°F (80°C), vinyl electrical tape should not be used. For these applications, adhesive cloth backed, flame retardant polyethylene or fiber glass tape (Delphi #PM-2203, Polikan #165 or equivalent) is recommended.



Criteria: Taping

The tape must extend a minimum of 1 in. (25 mm) past the conduit.

The tape must be crossed over butted conduit ends.

The tape must be extended a minimum of 1 in. (25 mm) in each direction at all branches.

THIS PAGE INTENTIONALLY LEFT BLANK

3.14 SENSORS

The DDEC IV system is designed to operate with several types of sensors as listed in Table 3-49.

Sensor Type	Description
Variable Reluctance	Used to monitor the crankshaft position and the engine speed.
Thermistor	Used to monitor temperatures.
Variable Capacitance	Used to monitor barometric air, manifold, oil gallery and optional pump pressures.
Variable Resistance (Potentiometer)	Used to sense throttle position. The output should be between .5 and 4.5 V.
Switch	Used to signal coolant level, inlet air restriction, and oil level.
Magnetic Pick-up	Used to sense vehicle speed, accumulate trip distance, and to use several vehicle features.

Table 3-49 Sensor Types

3.14.1 FACTORY-INSTALLED SENSORS

The sensors integrated into the factory-installed Engine Sensor Harness are listed in Table 3-50.

Sensor	Function
(Intake) Air Temperature Sensor (ATS)	Senses intake air temperature for functions such as fan control and engine fueling.
Barometric Pressure Sensor	Senses barometric pressure for EGR control.
Coolant Temperature Sensor (CTS)	Senses coolant temperature for functions such as engine protection, fan control and engine fueling.
EGR Delta Pressure Sensor (EGR Delta P)	Senses EGR pressure for EGR control.
EGR Temperature Sensor	Senses EGR temperature for EGR control.
Fuel Restriction Sensor (FRS)*	Senses fuel filter restriction to warn of the condition of the fuel filter for maintenance purposes.
Fuel Temperature Sensor (FTS)	Senses fuel temperature for engine fueling.
Oil Level Sensor (OLS)*	Senses oil level for functions such as engine protection.
Oil Pressure Sensor (OPS)	Senses gallery oil pressure for functions such as engine protection.
Oil Temperature Sensor (OTS)	Senses oil temperature for functions such as reducing variation in fuel injection, fan control and engine protection.
Synchronous Reference Sensor (SRS)	Indicates a specific cylinder in the firing order.
Timing Reference Sensor (TRS)	Senses crankshaft position and engine speed for functions such as fuel timing strategy.
Turbo Boost Sensor (TBS)	Senses turbo boost for functions such as smoke control, fuel control, and engine protection.
Turbo Compressor Out Temperature Sensor	Senses turbo out air temperature for EGR cooler protection.
Turbo Speed Sensor (TSS)	Senses turbo speed for overspeed protection.

* Available with the Maintenance Alert System

Table 3-50 Function of Factory-installed Sensors

3.14.2 AIR TEMPERATURE SENSOR

The ATS (see Figure 3-57) is a thermistor type sensor that has a variable resistance, when exposed to different temperatures. The ATS provides necessary input for various functions such as varying hot idle speed, fan control, and injection timing which results in improved cold starts and reduced white smoke.

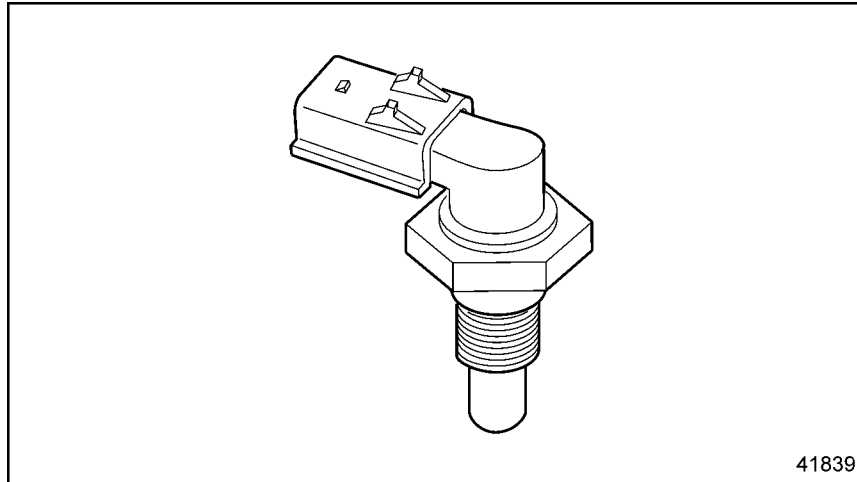

Figure 3-57 Air Temperature Sensor — Series 50 and Series 60

3.14.3 BAROMETRIC PRESSURE SENSOR

The Barometric Pressure Sensor (see Figure 3-58) senses barometric pressure for EGR control.

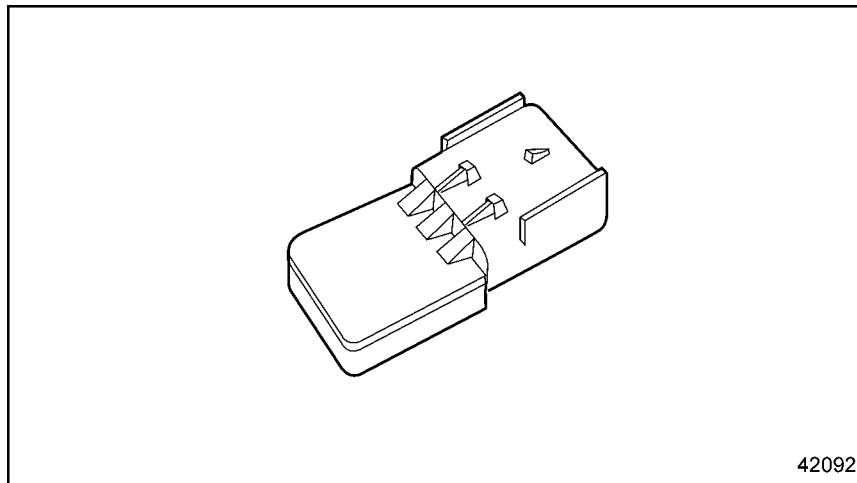

Figure 3-58 Barometric Pressure Sensor — Series 60 Only

3.14.4 COOLANT TEMPERATURE SENSOR

The CTS is a thermistor type sensor that has a variable resistance, when exposed to different temperatures. The CTS senses coolant temperature. See Figure 3-59 for the CTS used with the Series 60 engine and Figure 3-60 for the CTS used with the Series 50 engine.

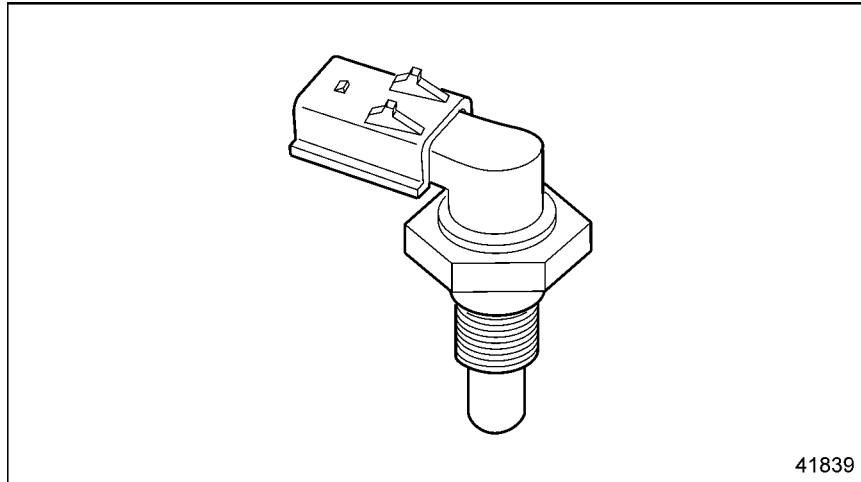

Figure 3-59 Coolant Temperature Sensor — Series 60

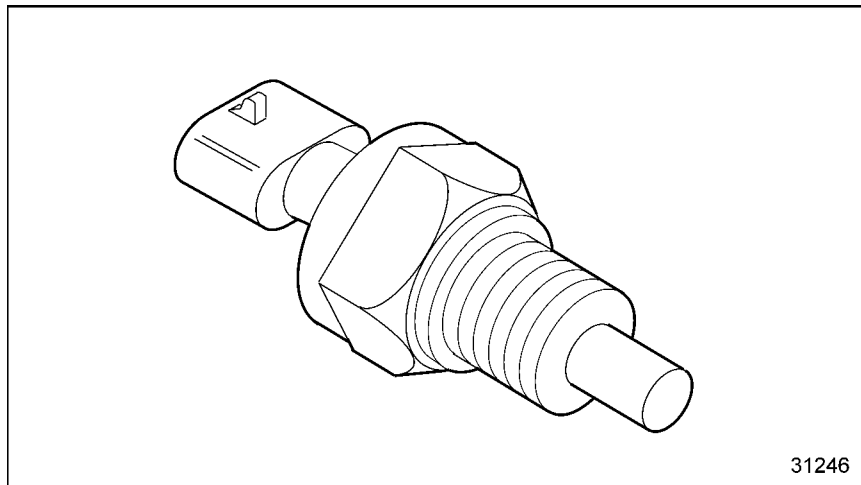

Figure 3-60 Coolant Temperature Sensor — Series 50

3.14.5 EGR DELTA PRESSURE SENSOR

The EGR Delta Pressure Sensor (EGR Delta P) senses EGR pressure for EGR control (see Figure 3-61).

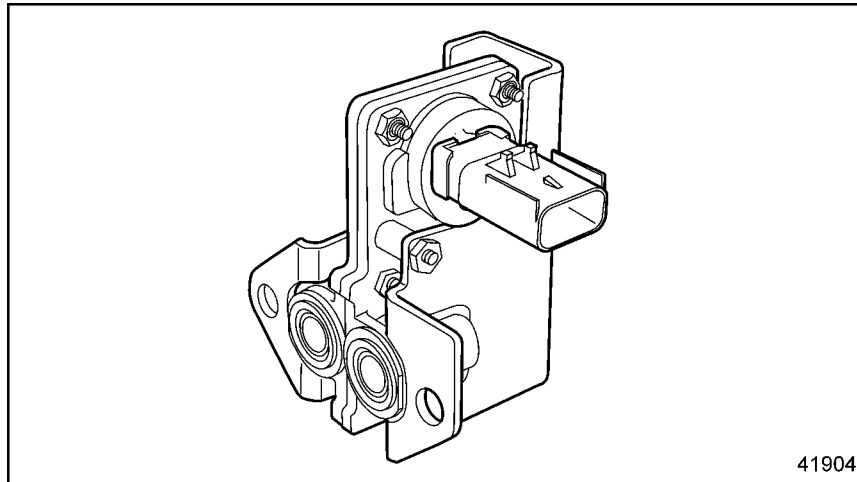

Figure 3-61 EGR Delta Pressure Sensor — Series 50 and Series 60

3.14.6 EGR TEMPERATURE SENSOR

The EGR Temperature Sensor senses EGR temperature for EGR control (see Figure 3-62).

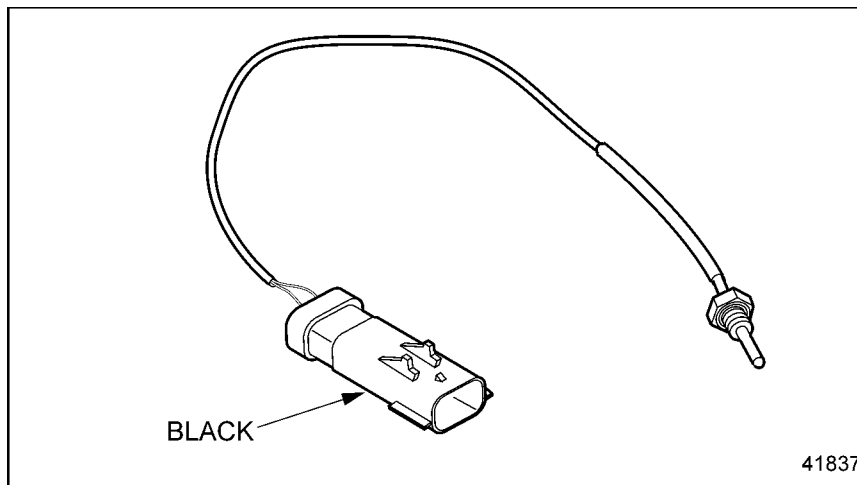

Figure 3-62 EGR Temperature Sensor — Series 50 and Series 60

3.14.7 FUEL RESTRICTION SENSOR

The FRS (see Figure 3-63) monitors the condition of the fuel filter. FRS is factory installed at DDC for applications which have the Maintenance Alert System (MAS).

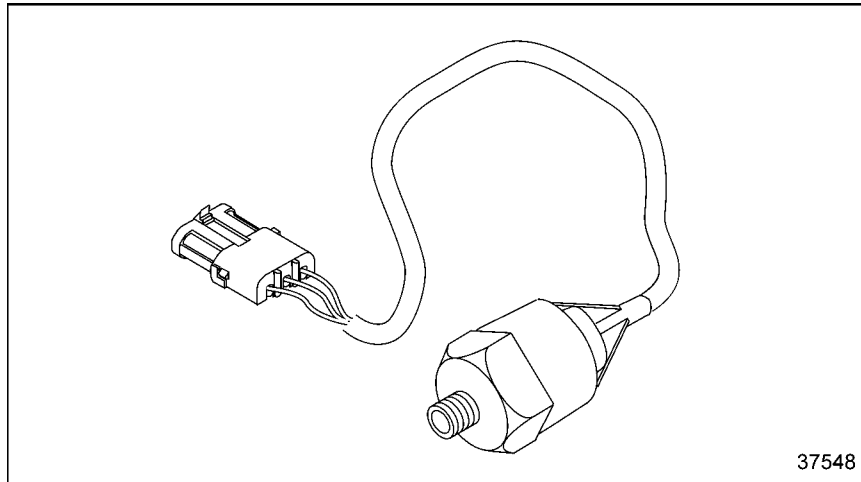

Figure 3-63 Fuel Restriction Sensor – Series 50 Only

3.14.8 FUEL TEMPERATURE SENSOR

The FTS (see Figure 3-64 and Figure 3-65) is a thermistor type sensor that has a variable resistance, when exposed to different temperatures. The FTS measures fuel temperatures necessary for fuel consumption calculations and fuel input compensation.

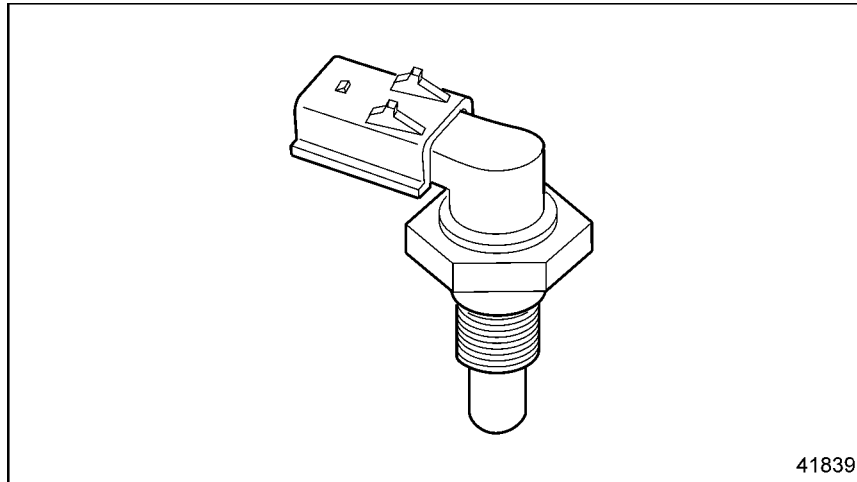

Figure 3-64 Fuel Temperature Sensor — Series 60

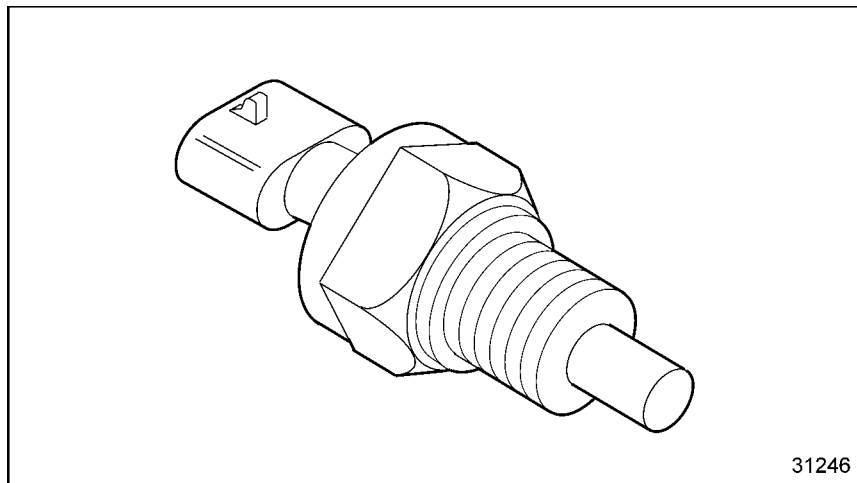

Figure 3-65 Fuel Temperature Sensor — Series 50

3.14.9 OIL LEVEL SENSOR

The OLS (see Figure 3-66) is factory-installed at DDC and is incorporated into the DDC Engine Sensor Harness for applications which have the Maintenance Alert System (MAS) for Series 50 only.

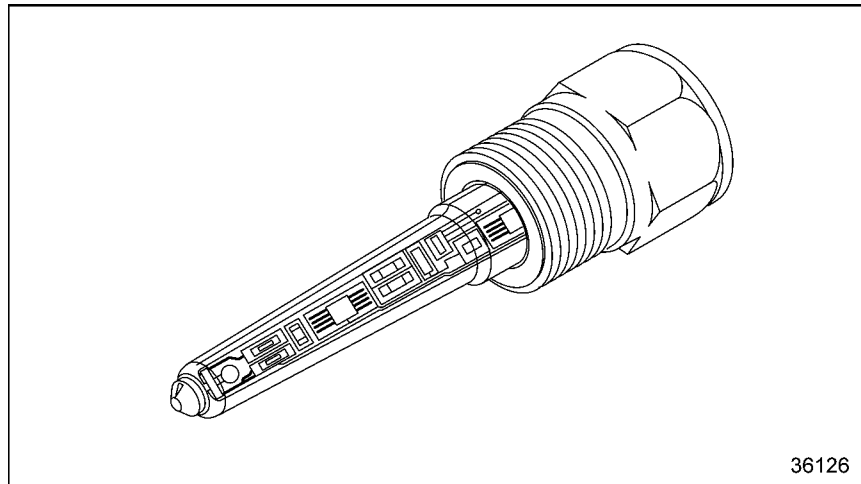

Figure 3-66 Oil Level Sensor – Series 50 Only

3.14.10 OIL PRESSURE SENSOR

The OPS is a variable capacitance sensor that produces a linear analog signal, indicating engine oil pressure.

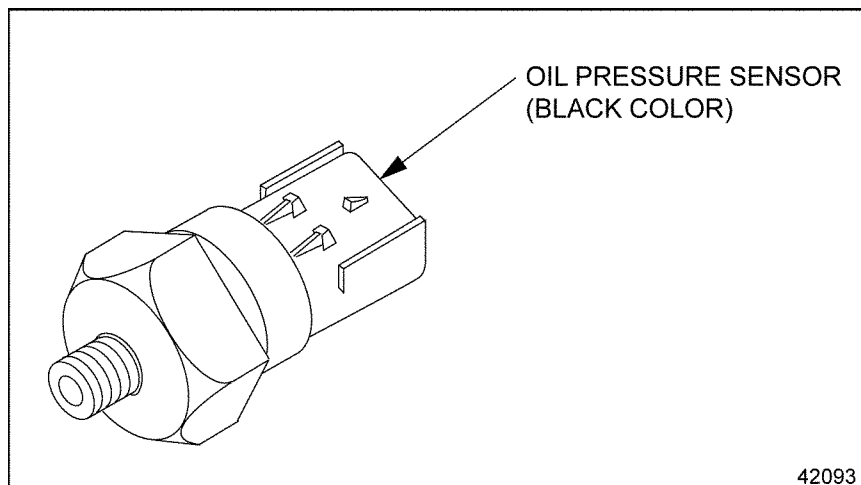

Figure 3-67 Oil Pressure Sensor — Series 50 and Series 60

3.14.11 OIL TEMPERATURE SENSOR

The OTS is a thermistor type sensor that has a variable resistance, when exposed to different temperatures.

See Figure 3-68 for the OTS used on the Series 60 engine and Figure 3-69 for the OTS used on the Series 50 engine.

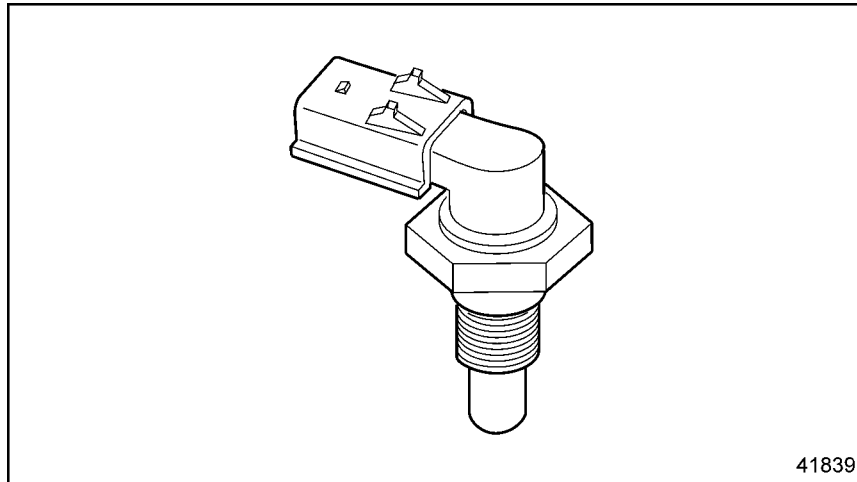

Figure 3-68 Oil Temperature Sensor - Series 60

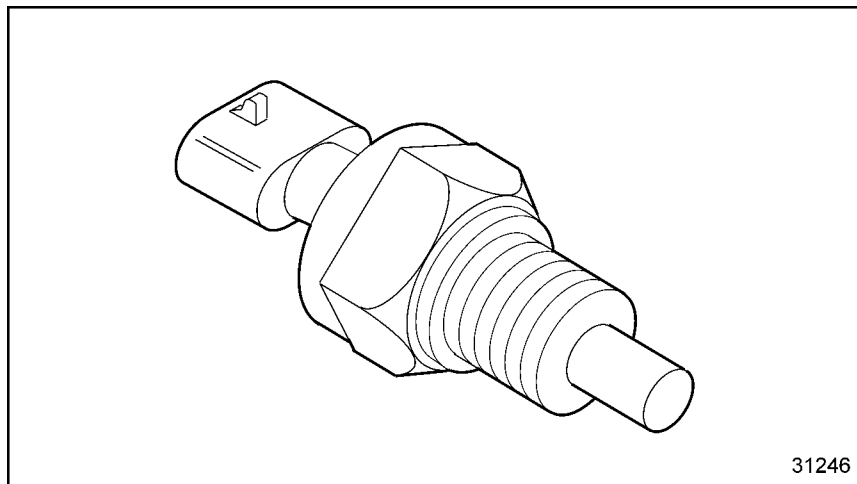

Figure 3-69 Oil Temperature Sensor — Series 50

The ECM uses the OTS signal to determine the quantity and timing of fuel required to optimize starting over a range of temperatures.

The OTS provides a signal to vary idle speed and injection timing resulting in improved cold starts and reduced white smoke. It also activates the engine protection, if the oil temperature exceeds the specified limits.

3.14.12 TIMING AND SYNCHRONOUS REFERENCE SENSORS

The Synchronous Reference Sensor (SRS) indicates a specific cylinder in the firing order.

The Timing Reference Sensor (TRS) is a variable reluctance type sensor that indicates crank position of every cylinder. The TRS tells the ECM where the position of the crankshaft is or when to fuel each cylinder.

See Figure 3-70 for the Series 60 engine TRS and SRS.

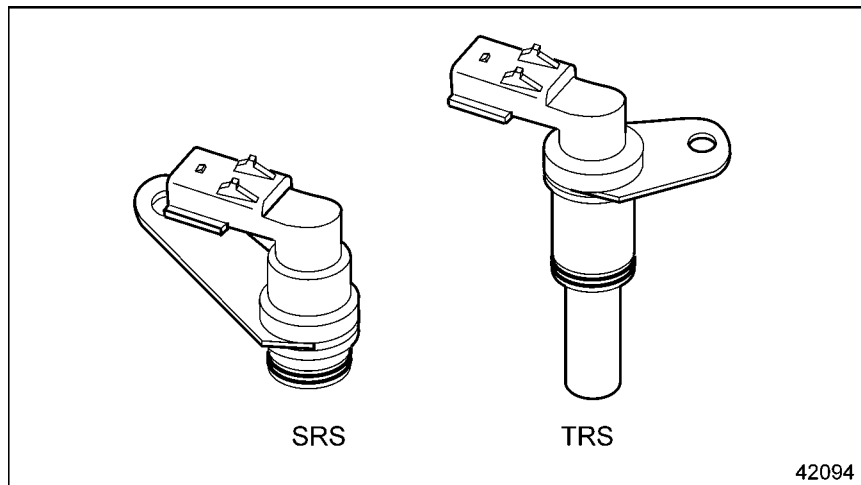

Figure 3-70 SRS and TRS — Series 60

See see Figure 3-71 for the Series 50 TRS and SRS.

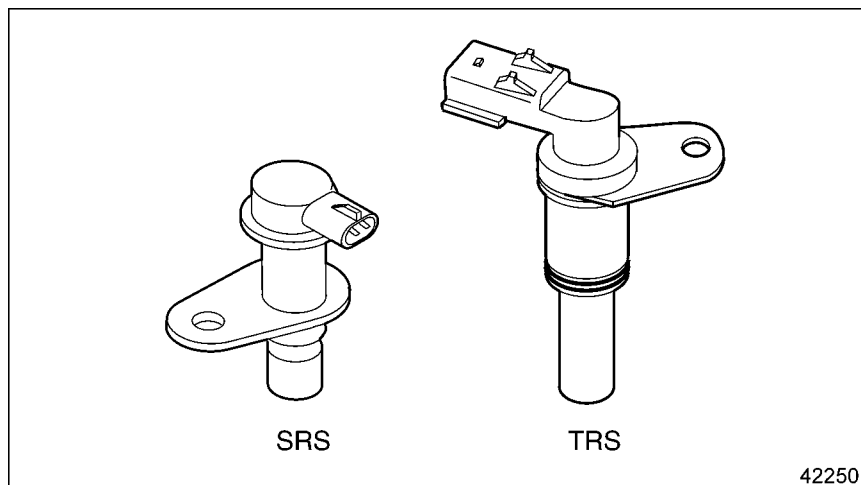

Figure 3-71 SRS and TRS — Series 50

3.14.13 TURBO BOOST SENSOR

The TBS provides data to the ECM for use in engine fueling (smoke control). See Figure 3-72 for the sensor used in on-highway applications.

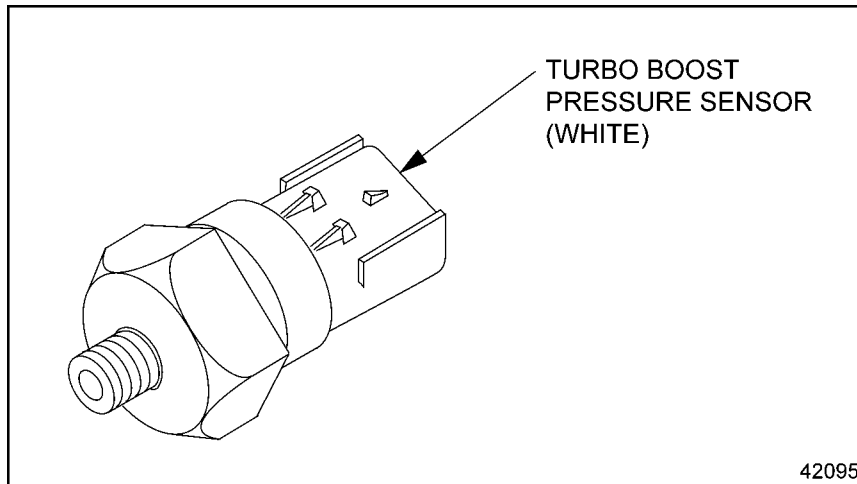

Figure 3-72 The Turbo Boost Pressure Sensor — Series 50 and Series 60

3.14.14 TURBO COMPRESSOR OUT TEMPERATURE SENSOR

The Turbo Compressor Out Temperature Sensor senses turbo out air temperature for EGR cooler protection. See Figure 3-73 for the sensor used with the Series 60 engine.

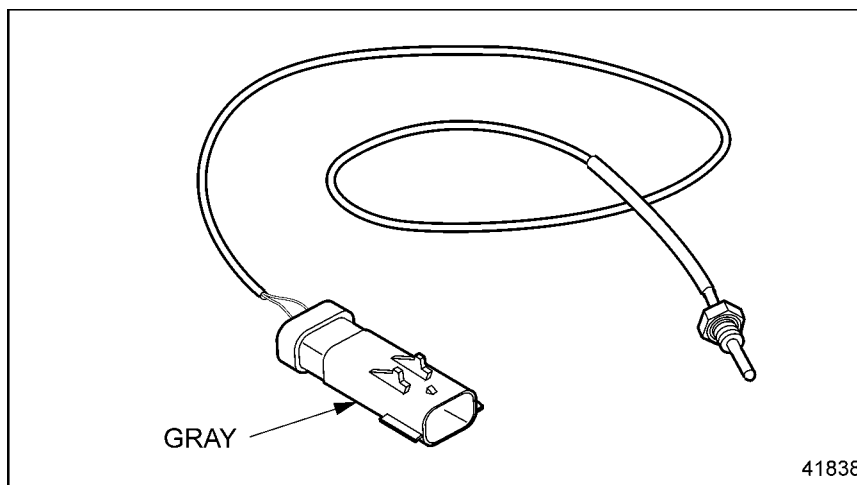

Figure 3-73 Turbo Compressor Out Temperature Sensor — Series 60

3.14.15 TURBO SPEED SENSOR

The Turbo Speed Sensor (TSS) senses turbo speed for overspeed conditions. See Figure 3-74.

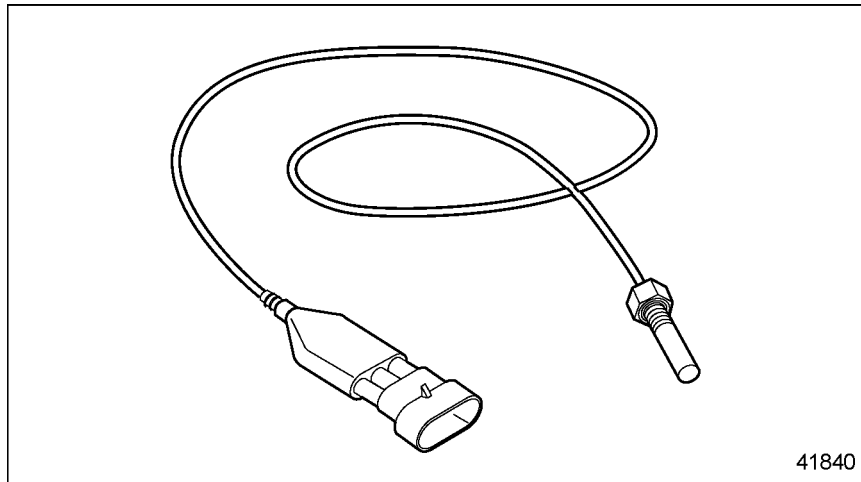

Figure 3-74 Turbo Speed Sensor — Series 50 and Series 60

3.14.16 OEM-INSTALLED SENSORS

All sensors must be of the proper type and continuously monitor vehicular and environmental conditions, so the ECM can react to changing situations.

The OEM is responsible for installing the sensors listed in Table 3-51. These sensors are application dependent.

Sensor	Part Number	Required or Optional	Function
Add Coolant Level Sensor (ACLS)*	23522855 23520830 23520381	Optional (Series 50 only)	Senses coolant level for engine maintenance. Refer to section 3.14.19.
Air Filter Restriction Sensor (AFRS)*	23526140	Optional (Series 50 only)	Senses the condition of the air inlet filter for engine maintenance. Refer to section 3.14.17.
Coolant Level Sensor (CLS)	23522855 23520380 23520381	Required	Senses coolant level for engine protection. Refer to section 3.14.18.
Exhaust Temperature Sensor*	23521882	Optional	Required for urban bus. Refer to section 3.14.21.
Fire Truck Pump Pressure Sensor *	23520795	Optional	Senses water pump pressure to maintain a constant fire truck pump pressure. Refer to section 3.14.22.
Optical Coolant Level Sensor*	23519175	Optional	Senses coolant level for engine protection in applications where electrical isolation from the chassis is required. Refer to section 3.14.20.
Relative Humidity/Turbo Compressor Inlet (TCI) Temperature Sensor*	23530572	Required (Series 60 and Natural Gas Applications)	Senses the temperature of the turbo compressor inlet and relative humidity. Refer to section 3.14.23.
Throttle Position Sensor (TPS)	--	Required	Senses operator's input to the ECM for throttle input. Refer to section 3.14.24.
Vehicle Speed Sensor (VSS)	--	Required	Senses vehicle speed for Cruise Control and PTO Control. Total distance accumulation required for ProDriver and a speedometer. Refer to section 3.14.25.

* Available in some applications

Table 3-51 Function and Guidelines for OEM-installed Sensors

NOTE:

The OEM harness must be securely fastened every 6 in. It is required that the harness be fastened within 6 in. of the sensor.

3.14.17 AIR FILTER RESTRICTION SENSOR — SERIES 50 ONLY

The AFRS is available only with the Maintenance Alert System (Release 27.0 or later software). The AFRS (see Figure 3-75) has two trip points, one at 18 in. of water and the second at 25 in. of water.

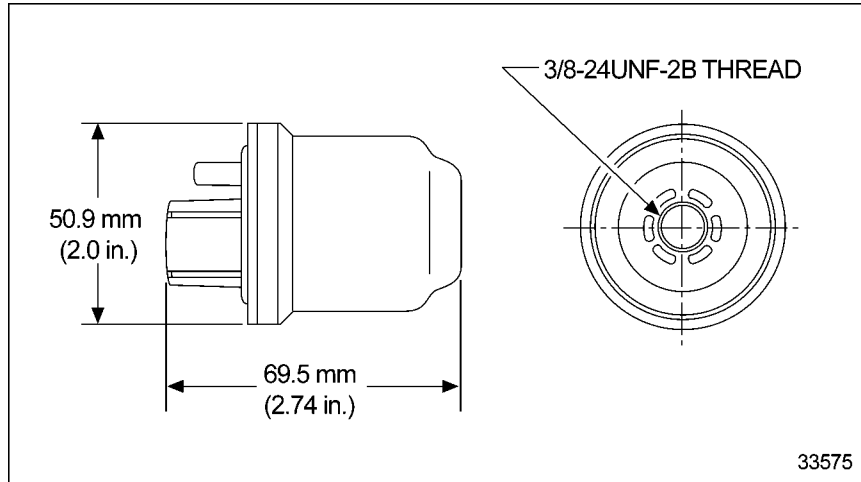

Figure 3-75 Air Filter Restriction Sensor

The AFRS is mounted downstream of the air filter and upstream of the turbocharger. The AFRS must be in a straight section of pipe or where the OEM mechanical unit is normally mounted. This sensor must be enabled with VEPS or the DDEC Reprogramming System (DRS). A pigtail on the DDC installed Engine Sensor Harness will be used to wire the sensor (see Figure 3-76).

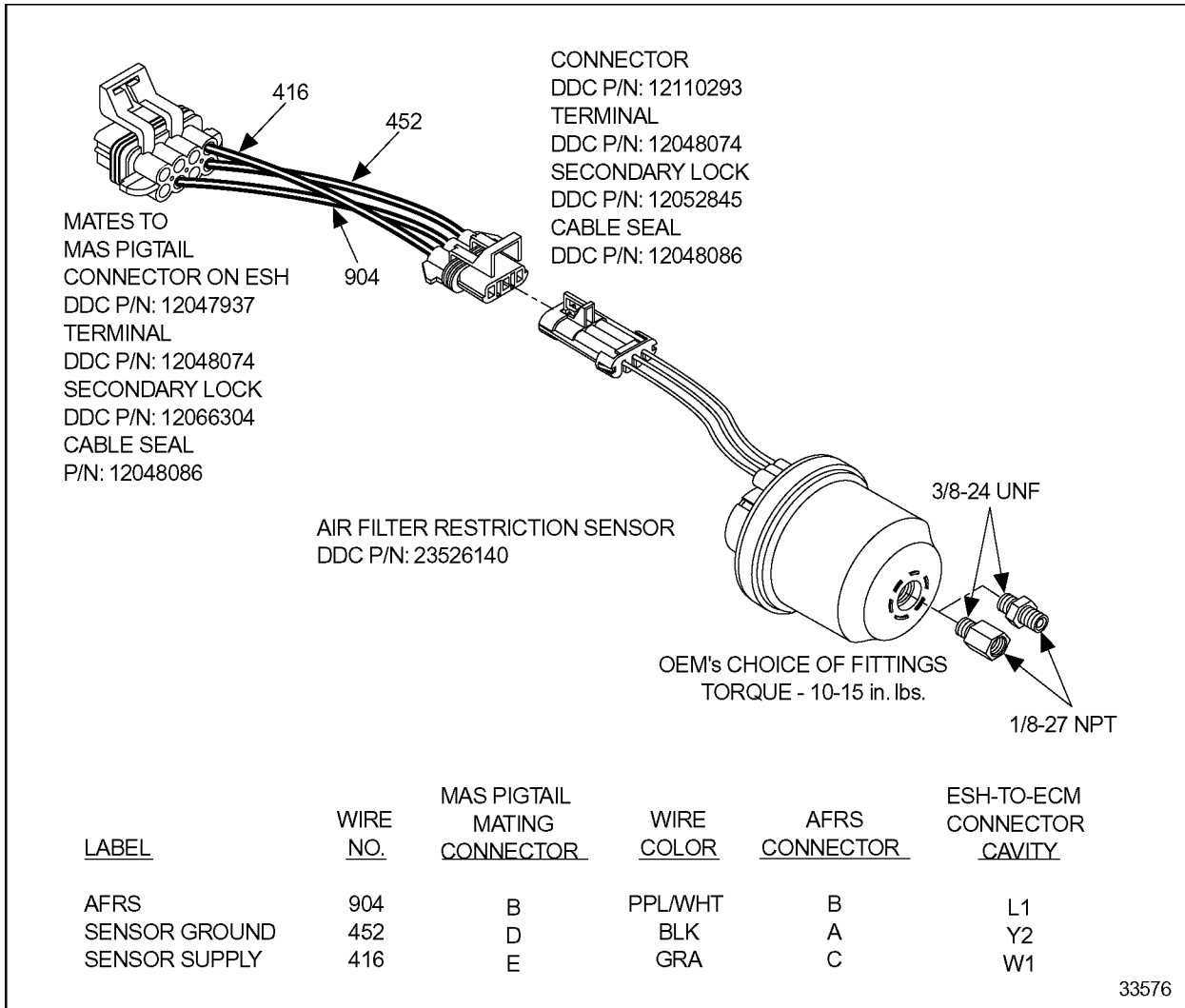

Figure 3-76 Air Filter Restriction Sensor Wiring Diagram

3.14.18 COOLANT LEVEL SENSOR

The CLS provides an input to the engine protection system that warns the operator if a low coolant level has been reached. Other non-DDC supplied coolant level sensors may be used but may require the use of a signal interface.

NOTE:

The CLS is required for DDEC IV installations.

The main component of the CLS consists of a conductivity probe, which connects to the ECM (see Figure 3-77).

NOTICE:
The probe has an operational temperature range of -40 to 257°F (-40 to 125°C). Exposure to temperatures beyond this range may result in unacceptable component life, or degraded sensor accuracy.

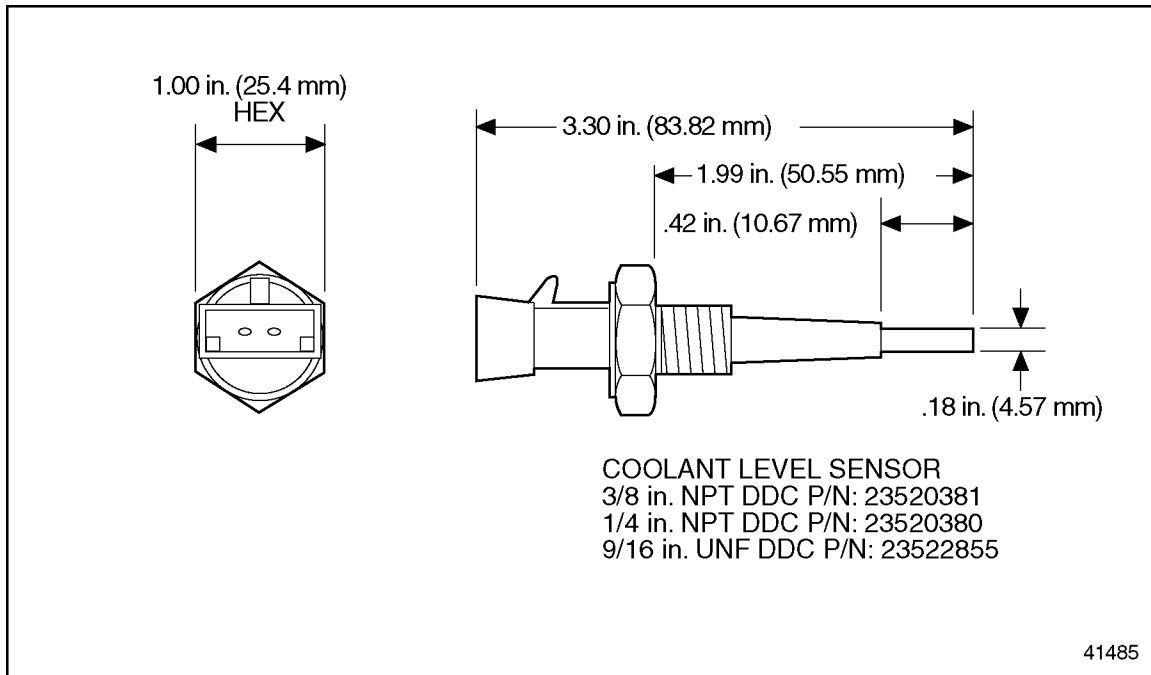

Figure 3-77 Coolant Level Sensor Specifications

The connector listed in Table 3-52 is a Metri-Pack 280 series push-to-seat connector.

Coolant Level Sensor Connector	
Connector	P/N: 15300027
Terminal	P/N: 12077411
Seal	P/N: 12015323
Secondary Lock	P/N: 15300014

Table 3-52 Metri-Pack 280 Connectors and Part Numbers

The OEM must connect the CLS probe as shown in the next illustration (see Figure 3-78). Polarity of the ground and signal must be correct for proper operation.

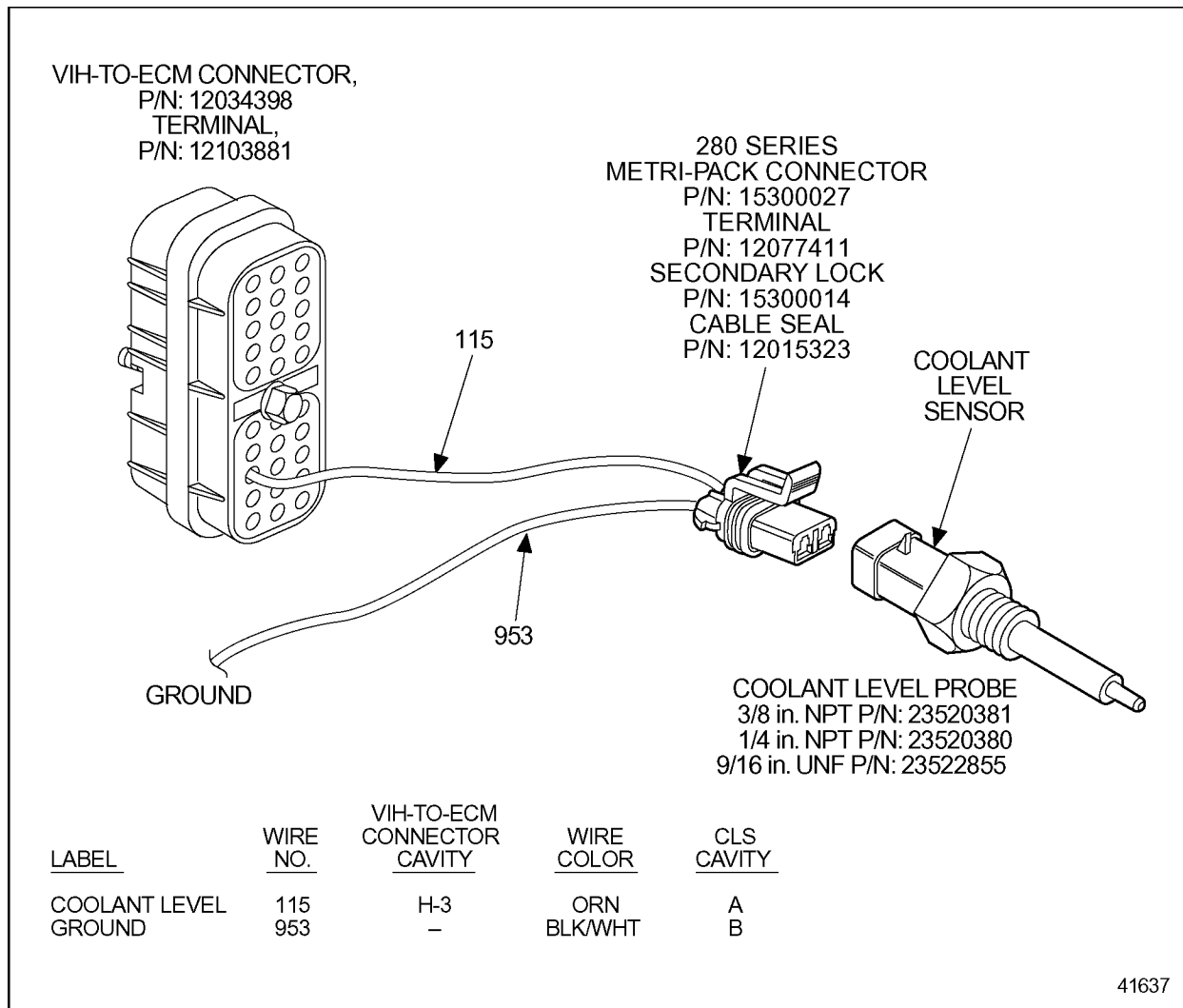

Figure 3-78 Coolant Level Sensor Installation

The probe should be located in either the radiator top tank or a remote mounted surge tank. It should be mounted horizontally in the center of the tank to minimize tilt operation sensitivity and must be in a position to signal low coolant before aeration occurs. Typically, this is a height representing 98% of the drawdown quantity. The probe should be located so that it is not splashed by deaeration line, stand pipe or coolant return line flows. The insulated portion of the probe should be inserted into the coolant .5 in. or more past the inside wall of the tank. See Figure 3-79.

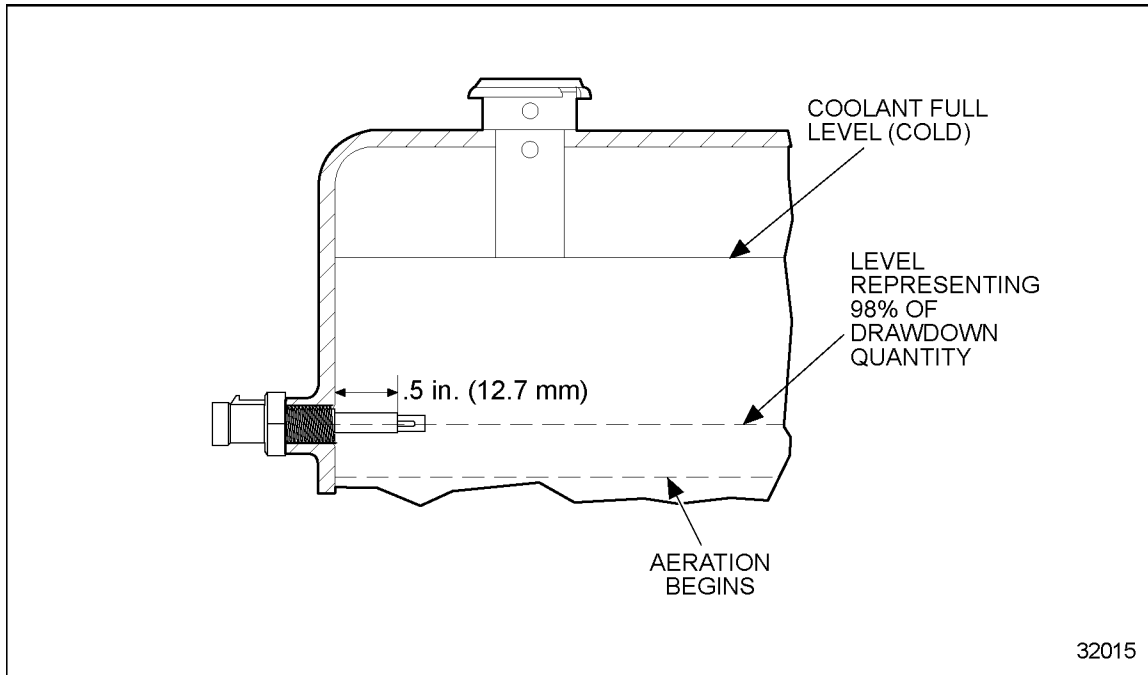

Figure 3-79 Coolant Level Sensor Location - Top of Radiator Tank

Determine proper location for low coolant level sensor while running the drawdown test. It *must* actuate a warning before the satisfactory drawdown level is reached.

The CLS components are OEM-supplied hardware and can be purchased as kits or individual components, depending on OEM requirements.

The following kits listed in Table 3-53 and Table 3-54 provide all the necessary hardware for proper installation of the CLS. Kits are available through the DDC parts distribution network.

Component	Part Number
CLS Probe	23520380
Metri-Pack Connector Kit	15300027
Metri-Pack Terminals	12077411
Secondary Lock	15300014
Cable Seal	12015323
Terminal	12103881

Table 3-53 CLS Installation Kit 1/4 in. NPTF P/N: 23515397

Component	Part Number
CLS Probe	23520381
Metri-Pack Connector Kit	15300027
Metri-Pack Terminals	12077411
Secondary Lock	15300014
Cable Seal	12015323
Terminal	12103881

Table 3-54 CLS Installation Kit 3/8 in. NPTF P/N: 23515398

3.14.19 ADD COOLANT LEVEL SENSOR — SERIES 50 ONLY

The ACLS is used to warn the driver that the coolant level is below the recommended level. If the tank is equipped with an "ADD" level, the sensor should be installed there. This sensor will be activated approximately mid-way between the cold full level and the level where the standard (engine protection) CLS is located (see Figure 3-80).

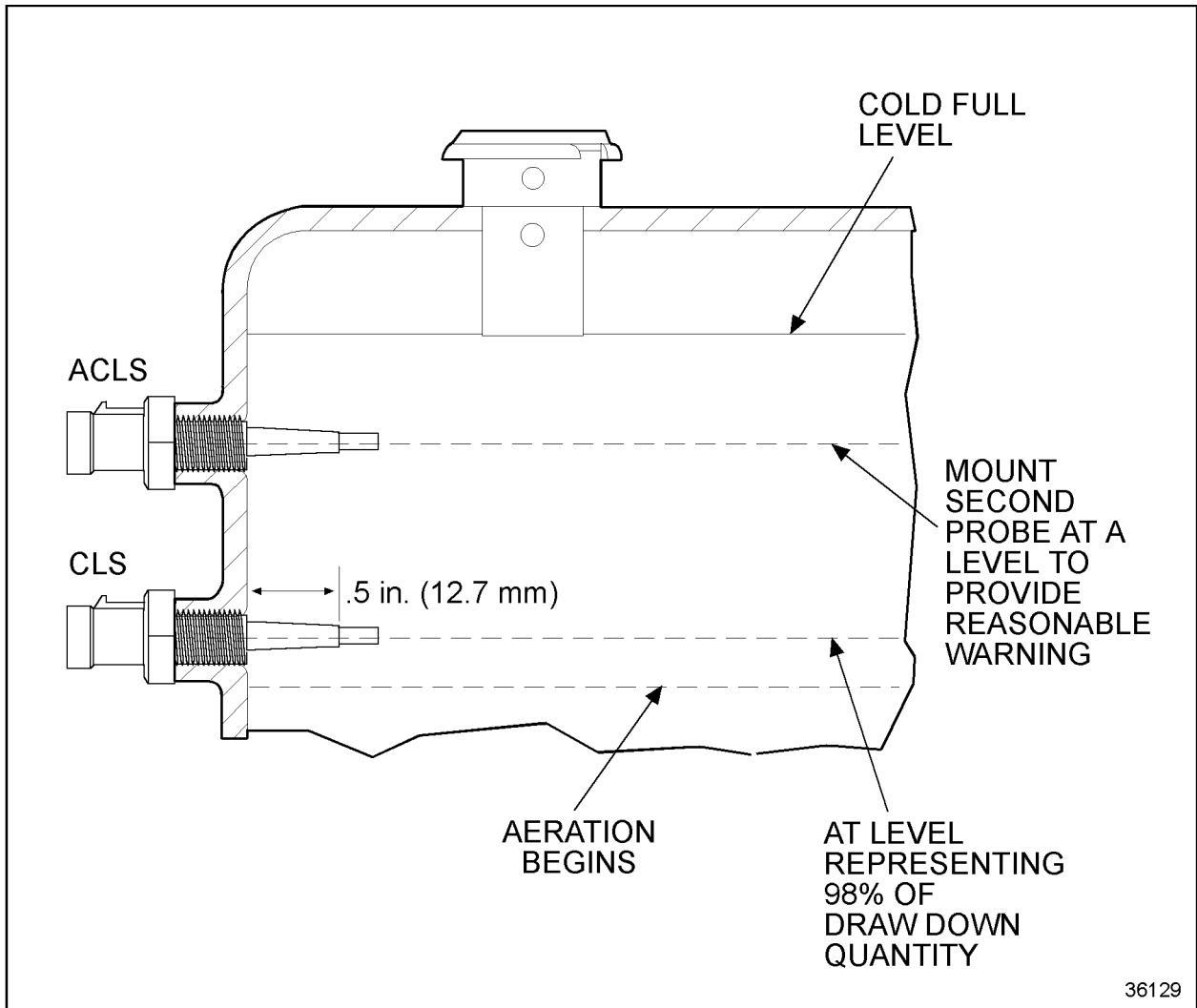

Figure 3-80 Add Coolant Level Sensor Location - Radiator Surge Tank

NOTE:

All ACLS components are OEM installed.

The ACLS must be enabled with VEPS or DRS. The ACLS will require an additional module (P/N: 23524054) to condition the sensor signal. The module output will be connected to the MAS pigtail on the supplied ESH. See Figure 3-81.

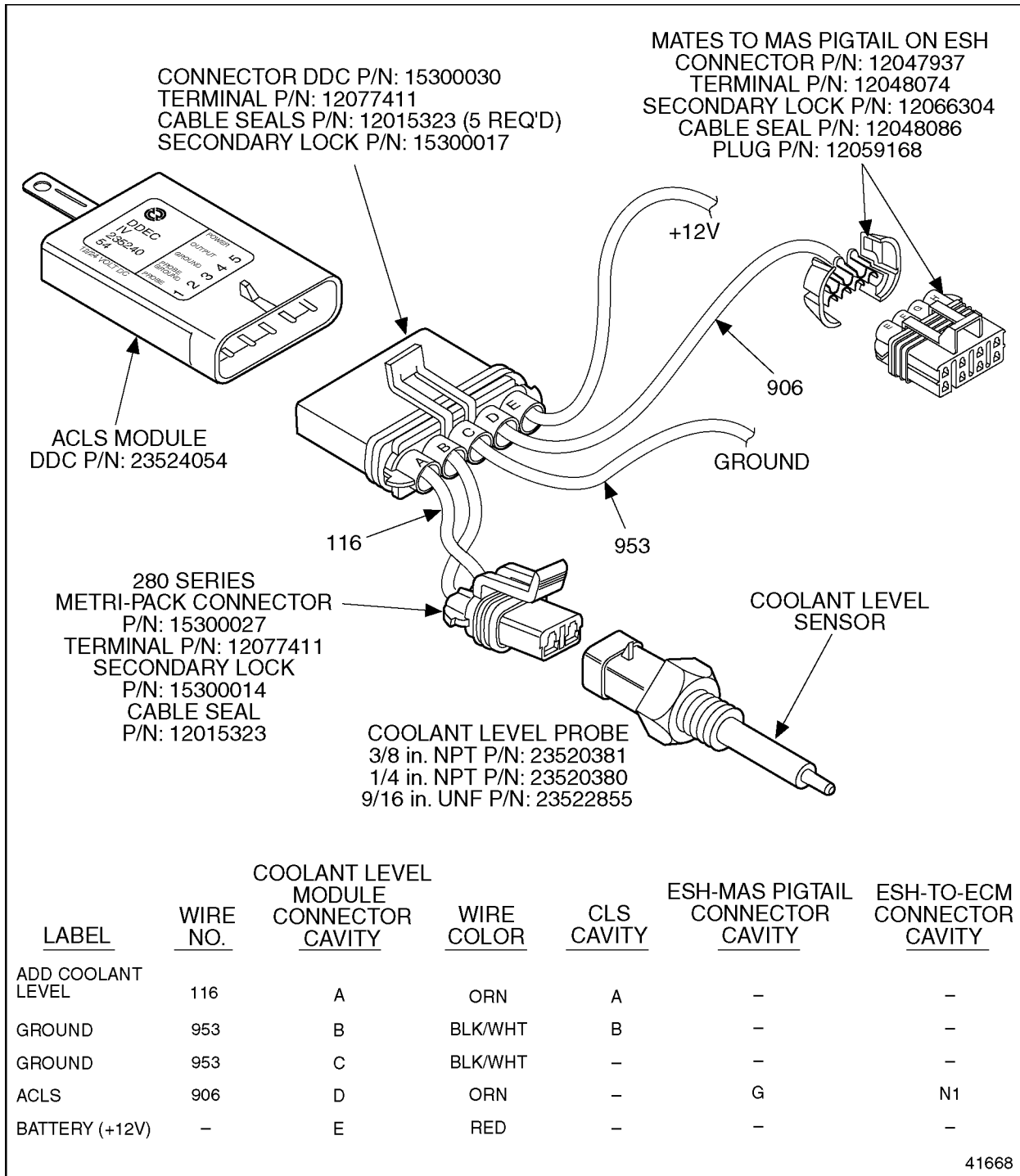

Figure 3-81 Add Coolant Level Sensor Installation – MAS

3.14.20 OPTICAL COOLANT LEVEL SENSOR

The optical CLS (see Figure 3-82) can be used in place of the standard coolant level sensor in applications where electrical isolation from the chassis is required.

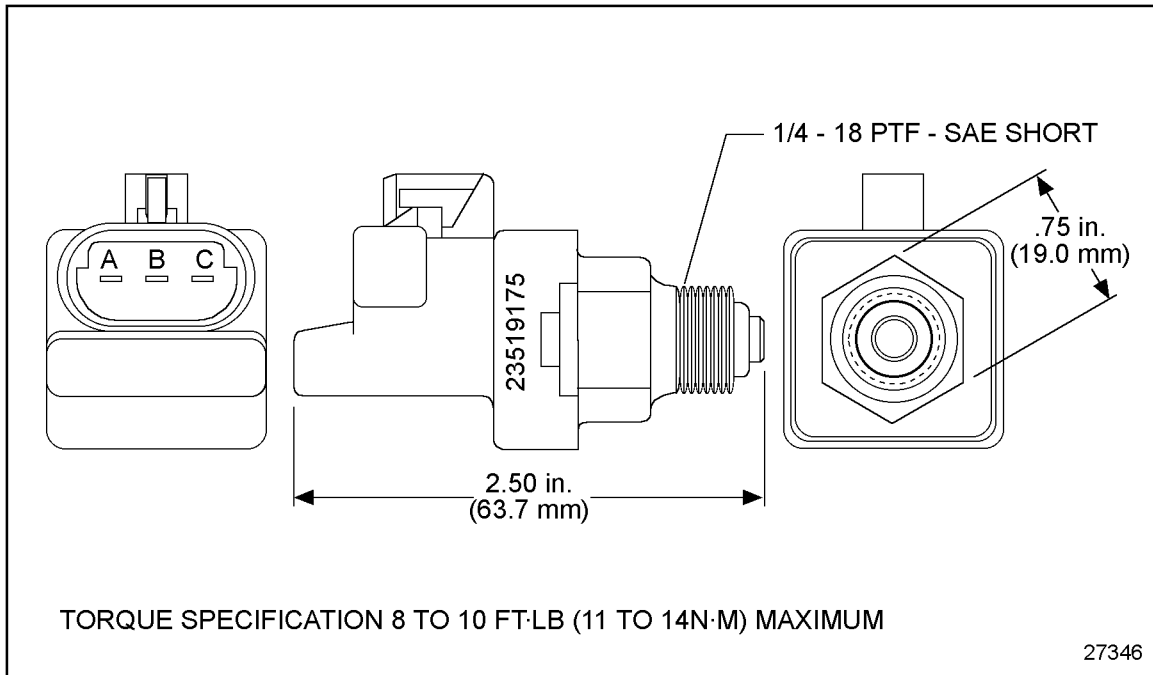

Figure 3-82 Optical Coolant Level Sensor Specifications

NOTE:

This sensor is optional.

The optical CLS does not have a connection to the chassis but uses the angle of refraction of light emitted from the probe to determine if the sensor is in or out of the coolant. See Figure 3-83 for a schematic of the optical CLS harness.

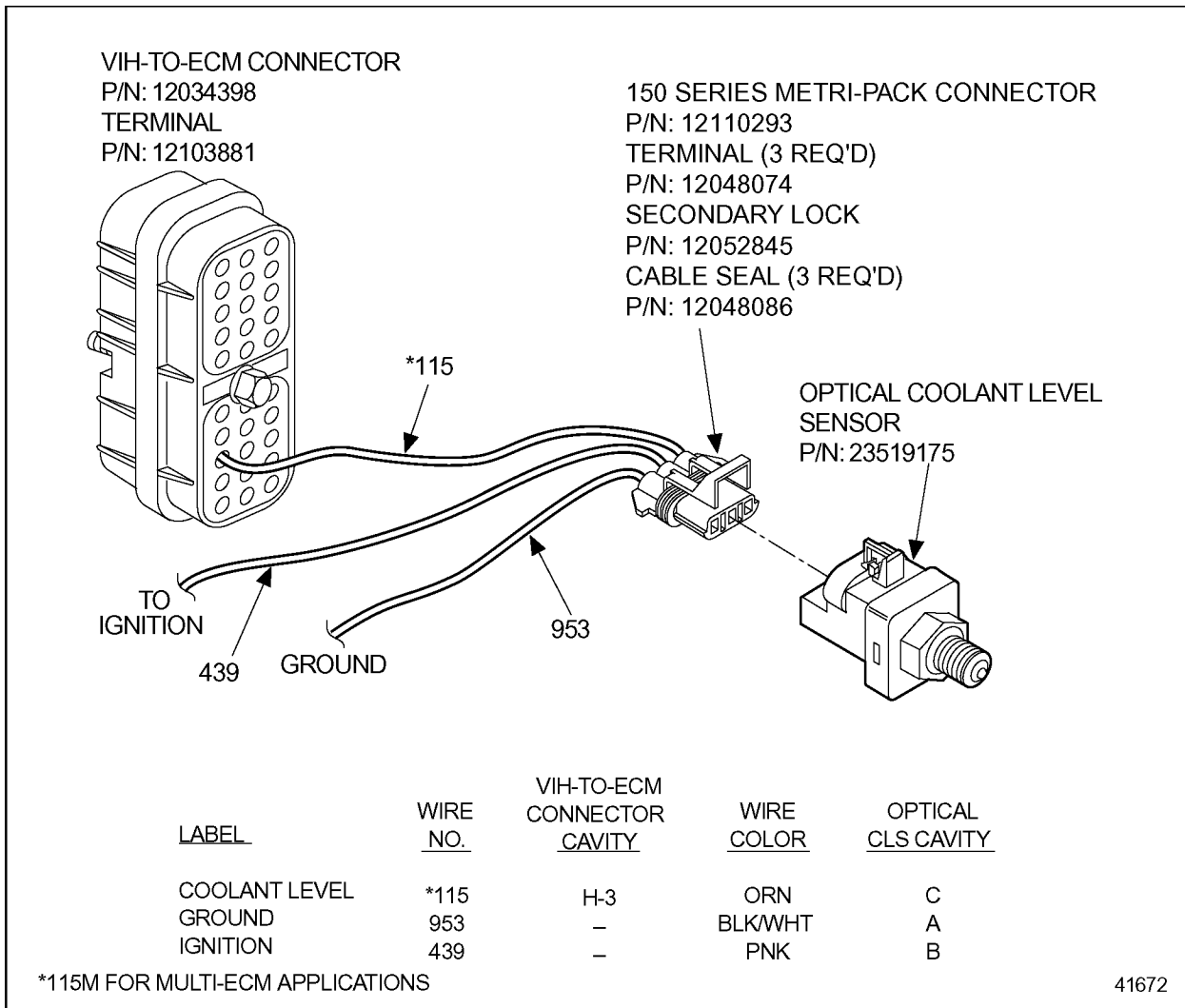

Figure 3-83 Optical Coolant Level Sensor Harness

The sensor part numbers are listed in Table 3-55.

Description	Part Number
Optical CLS	23519175
Connector	12110293
Terminals	12048074
Cable Seals	12048086
Secondary Lock	12052845

Table 3-55 Optical Coolant Level Sensor and Parts

3.14.21 EXHAUST TEMPERATURE SENSOR

Excessive exhaust temperature may indicate a concern with the fuel system or a mechanical fault. An Exhaust Temperature Sensor (see Figure 3-84) will provide early warning and prevent damage for certain applications. This sensor is configured by the Application Code System (ACS).

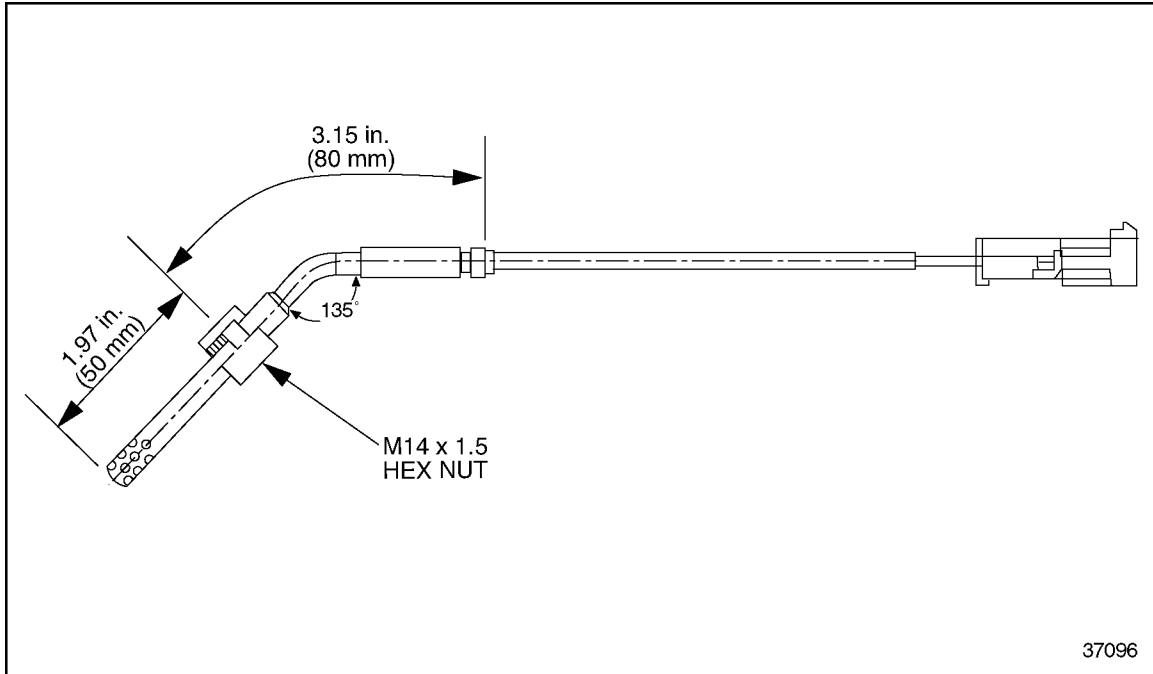

Figure 3-84 Exhaust Temperature Sensor

Exhaust Temperature Sensor Installation

Kits containing the Exhaust Temperature Sensor Harness and sensor are available from Canton Parts Distribution Center. The kits are listed in Table 3-56.

Kit Part Numbers	Description	Component Part Numbers
23531227	Harness - 232 in.*	23531076
	Exhaust Temperature Sensor	23521882
23531228	Harness - 170 in. length*	23531075
	Exhaust Temperature Sensor	23521882
23531229	Harness - 100 in. length*	23531074
	Exhaust Temperature Sensor	23521882

* Total length includes 72 in. lead on P/N: 23521882

Table 3-56 Exhaust Temperature Sensor and Harness Kits

To install the Exhaust Temperature Sensor (see Figure 3-85):

1. Unplug the connector from the TBS.
2. Plug the Exhaust Temperature Sensor Harness connector (P/N: 12162182) into the TBS.
3. Plug the TBS connector (from the ESH) you unplugged in step 1 into the 3-pin connector on the Exhaust Temperature Sensor Harness.
4. Route the harness along the ESH toward the ECM-VIH 30-pin connector. Remove the VIH 30-pin connector from the ECM.
5. Insert the single lead (circuit 749) into cavity D3 of the VIH 30-pin connector. Crimp the terminal on the lead and pull to seat.

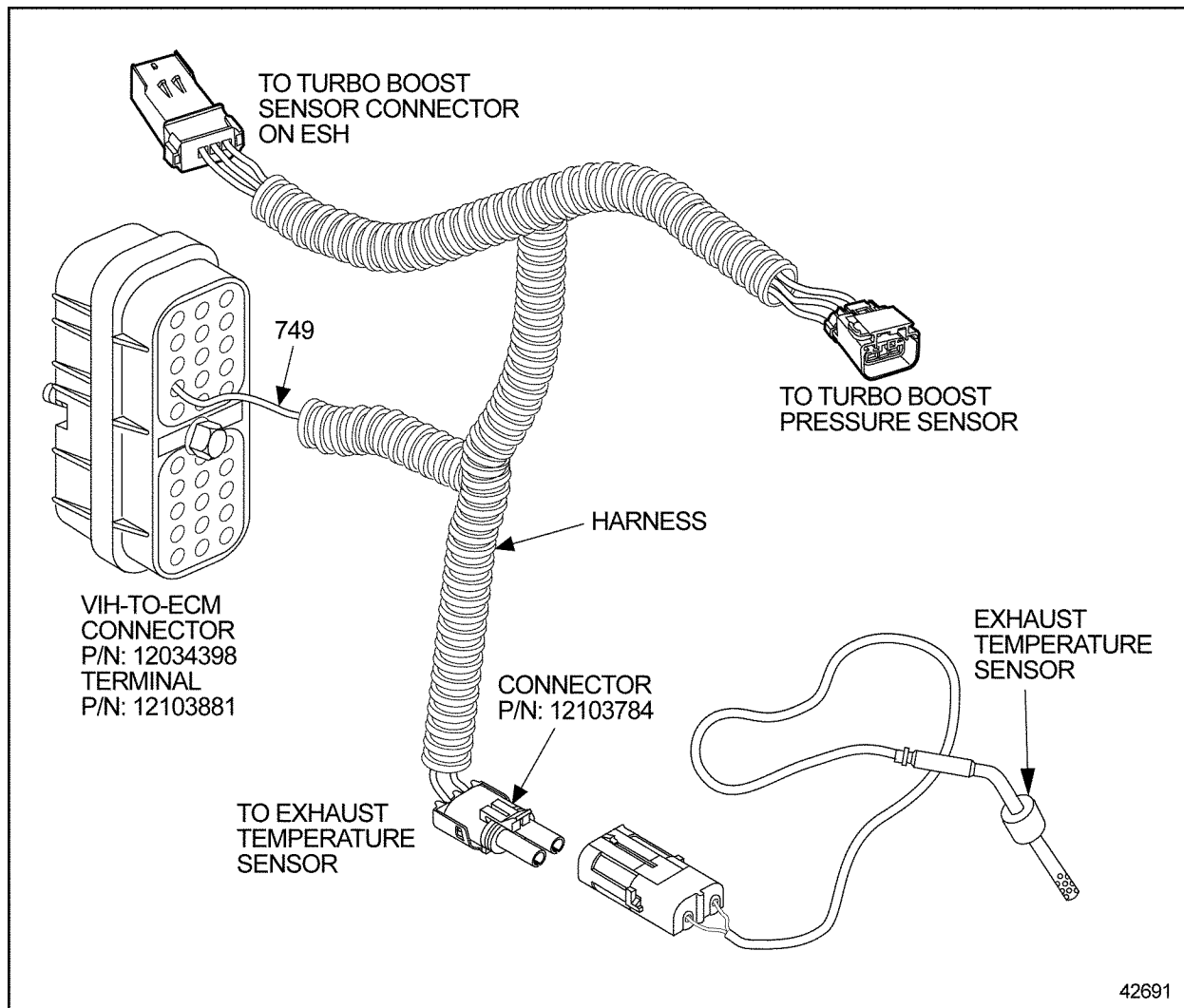

Figure 3-85 Exhaust Temperature Sensor Installation

6. Reinstall the VIH 30-pin connector.
7. Route the body of the harness to the location of the Exhaust Temperature Sensor and plug the connector (P/N: 12103784) into the sensor.

3.14.22 FIRE TRUCK PUMP PRESSURE SENSOR

The Fire Truck Pump Pressure Sensor is used with the DDEC IV pressure sensor governor. It provides a fire truck pump pressure signal to the ECM, which modulates engine fueling to maintain a constant fire truck pump pressure. See Figure 3-86. The Pressure Sensor is capable of reading up to 400 psia and is located in the water pump discharge manifold.

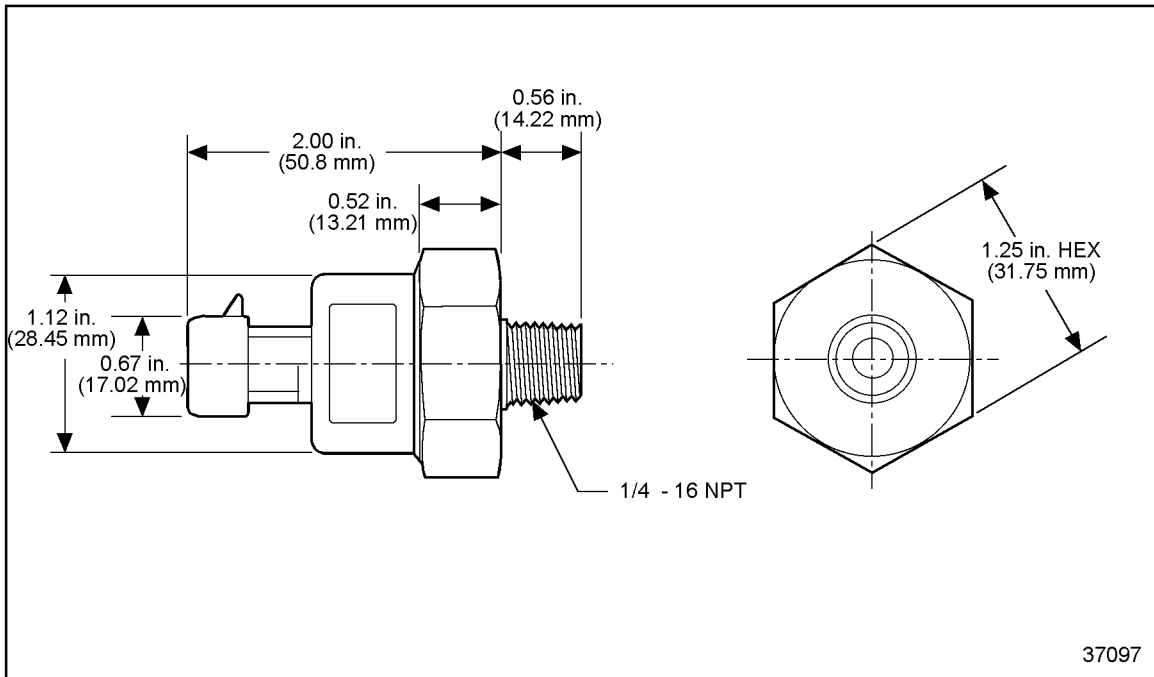

Figure 3-86 The Fire Truck Pump Pressure Sensor

NOTE:

This sensor is optional.

The Fire Truck Pump Pressure Sensor connector, listed in Table 3-57, is a Metri-Pack 150 series pull-to-seat connector.

Fire Truck Pressure Sensor (PSG)	
Connector	P/N: 12065287
Terminal	P/N: 12089289
Cable Seal	P/N: 12065285

Table 3-57 Fire Truck Pump Pressure Sensor Connector

See Figure 3-87 for the installation of the Fire Truck Pump Pressure Sensor.

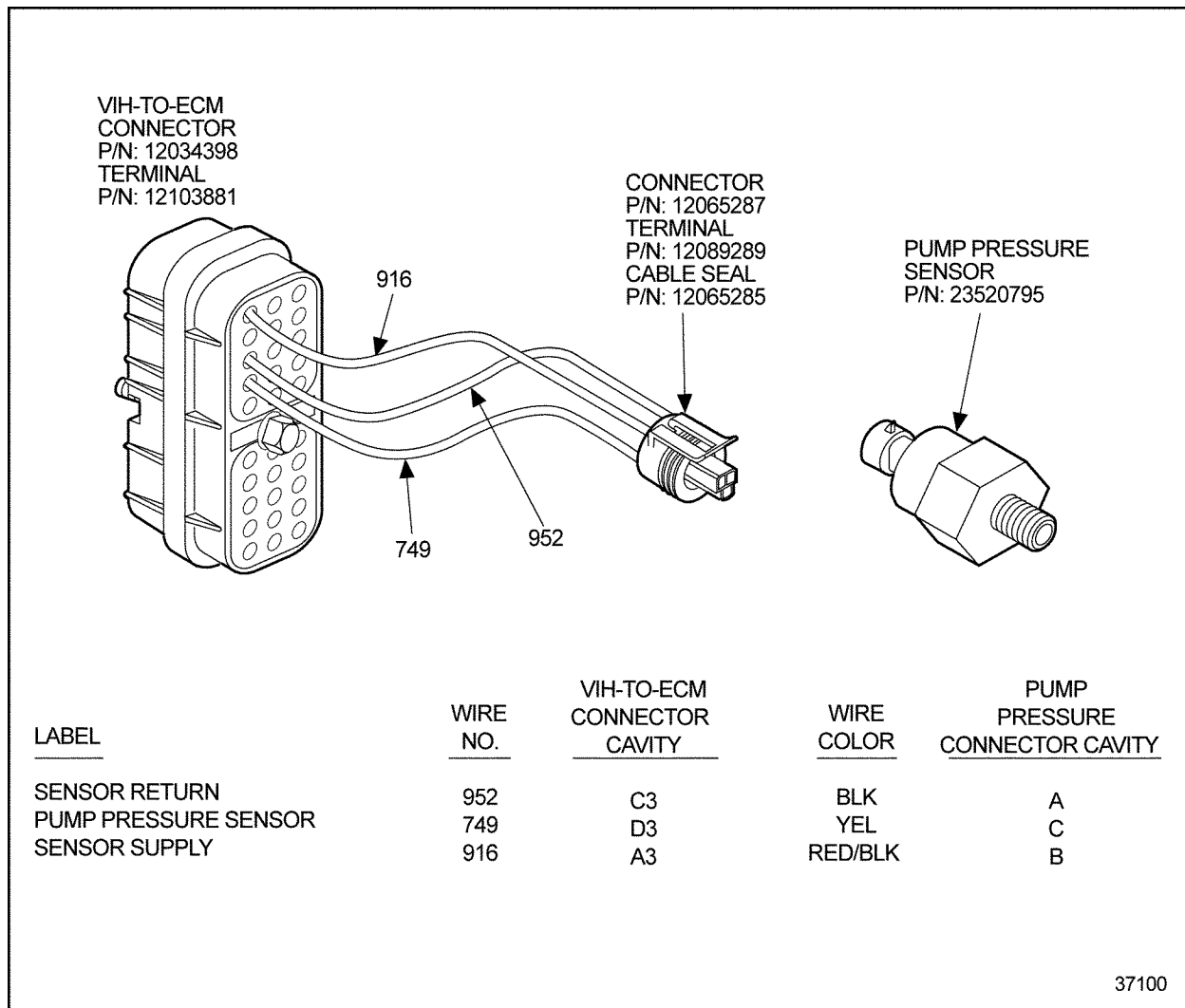

Figure 3-87 Fire Truck Pump Pressure Sensor Installation

3.14.23 RELATIVE HUMIDITY/TURBO COMPRESSOR INLET TEMPERATURE SENSOR

The Relative Humidity/Turbo Compressor Inlet (TCI) Temperature Sensor senses the temperature of the turbo compressor inlet and relative humidity. The maximum vibration for the sensor is 5 g. The sensor should be torqued between 15 ft·lb (20 N·m) and 25 ft·lb (34 N·m). See Figure 3-88 for the dimensions of the sensor. The harness must be fastened within 6 in. of the sensor.

NOTE:

The sensor is shipped with the engine.

NOTE:

This sensor is required for Series 60 and natural gas applications.

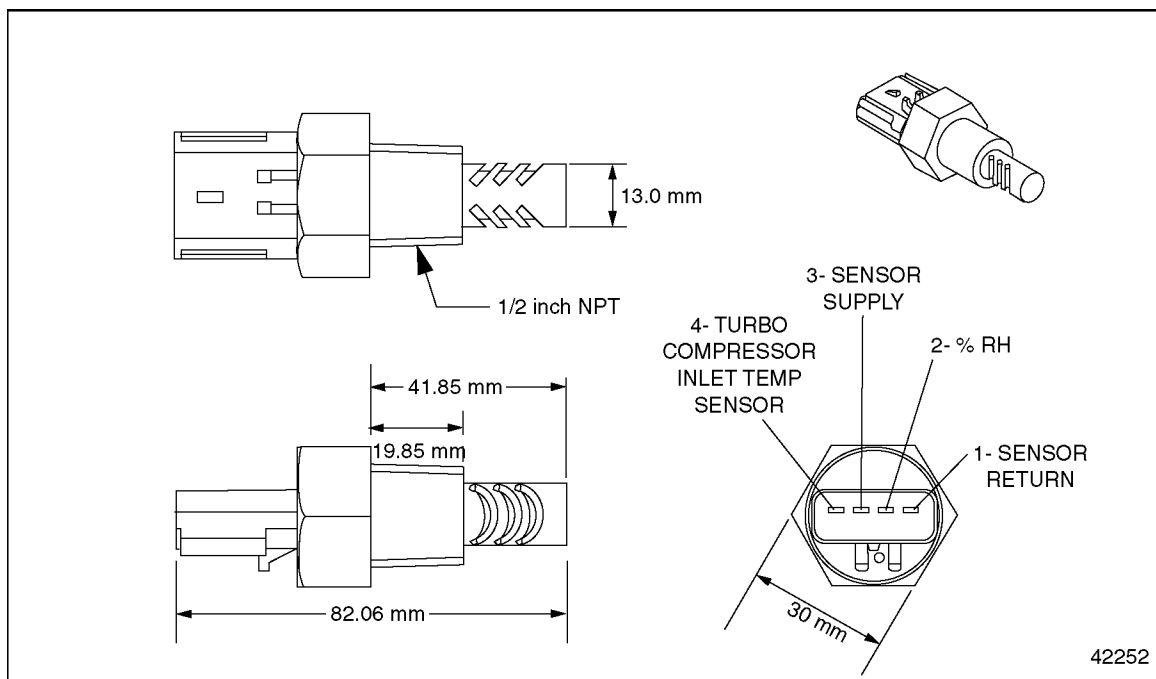

Figure 3-88 Relative Humidity/TCI Temperature Sensor Dimensions

Installation of Relative Humidity/TCI Temperature Sensor

The maximum operating temperature for this sensor is 185°F (85°C). The maximum vibration for the sensor is 5 g. The sensor should be mounted in the filtered air side of the air filter canister. Otherwise it must be mounted between the air cleaner and the turbocharger compressor inlet. The harness must be fastened within 6 in. of the sensor.

The OEM is responsible for wiring this sensor to the 10-pin OEM interface connector for Series 60 only. See Figure 3-89.

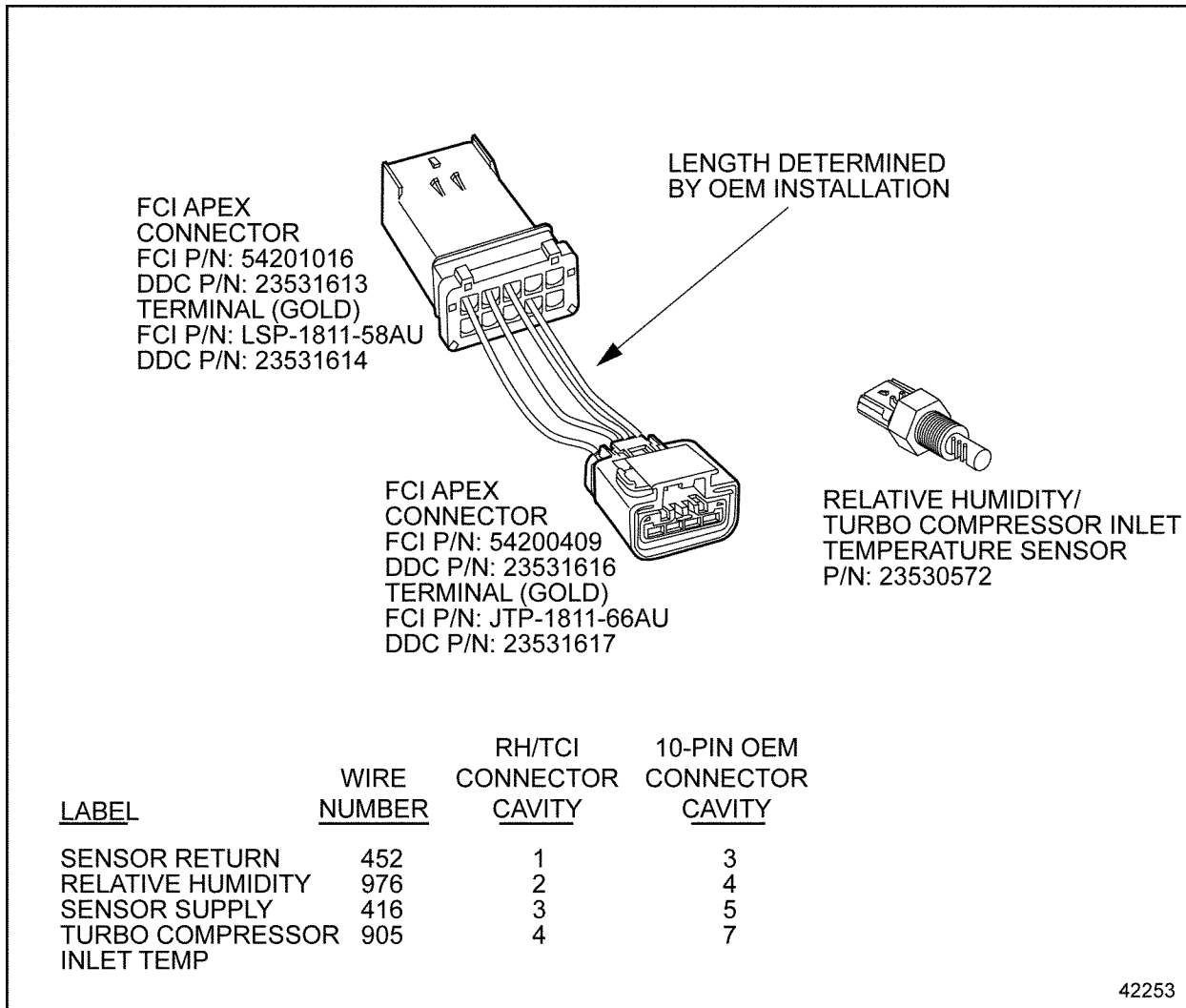

Figure 3-89 Relative Humidity/TCI Temperature Sensor Installation for Series 60 Only

For natural gas applications, the Relative Humidity/TCI Temperature Sensor is wired to the Vehicle Interface Harness. See Figure 3-90.

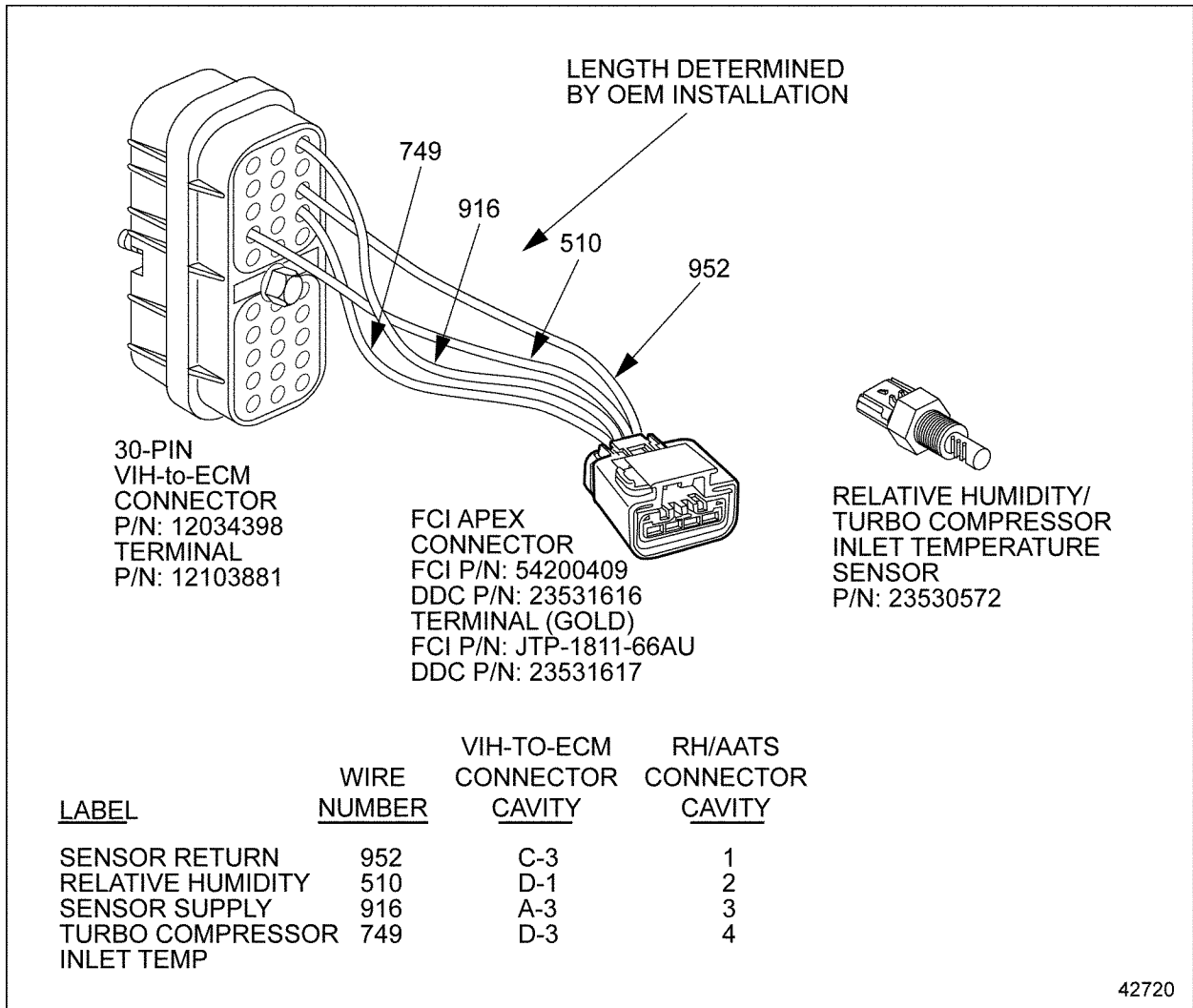

Figure 3-90 Relative Humidity/TCI Temperature Sensor Installation for Natural Gas Applications

The maximum operating temperature for this sensor is 185°F (85°C). The maximum vibration for the sensor is 5 g.

3.14.24 THROTTLE POSITION SENSOR

The EFPA contains the Throttle Position Sensor (TPS) which converts the operator's hand throttle and/or foot pedal input into a signal for the ECM. Refer to section 3.15.1 for additional information on the Electronic Foot Pedal Assembly.

NOTE:

This sensor is required.

3.14.25 VEHICLE SPEED SENSOR

The DDEC IV ECM can calculate vehicle speed providing that the ECM is properly programmed and interfaced with a vehicle speed signal that meets DDC requirements. The VSS (see Figure 3-91) provides a vehicle speed signal for use in Cruise Control and Vehicle Speed Limiting. The VSS signal type can be changed with the DDR, VEPS, or DRS.

NOTE:

DDC does not approve of the use of signal generator sensors.

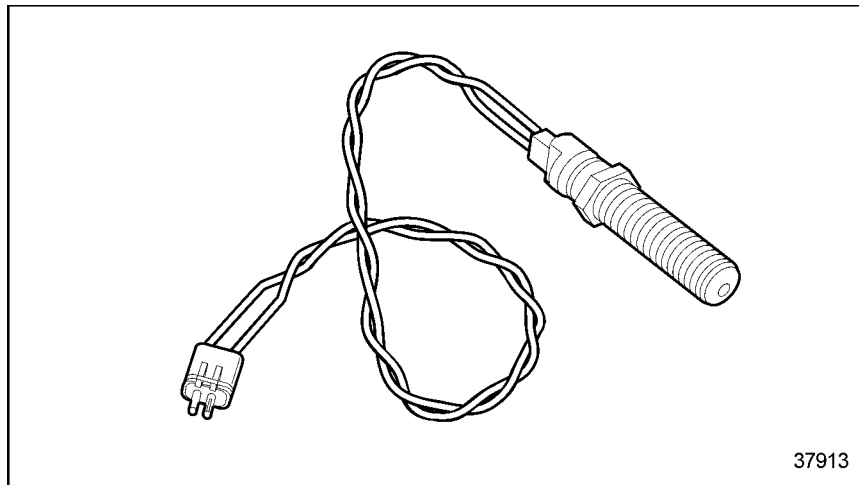

Figure 3-91 Vehicle Speed Sensor

To obtain accurate vehicle mileage, the parameters listed in Table 3-58 must be programmed with the DDR, DDDL, VEPS, DRS or at order entry.

Parameter	Description	Choice / Display
VSS ENABLED	Enables or disables the vehicle speed sensor input.	YES, NO
VSS TYPE	Type of vehicle speed sensor used	TAIL, WHEEL
VSS TEETH	Number of teeth on the vehicle speed sensor wheel.	0 to 250
VSS SIGNAL	Type of vehicle speed sensor signal.	SWITCHED, MAGNETIC
TIRE REVS/MI or REV/KM	Vehicle tire revolutions per mile.	100 to 999
AXLE RATIO	Indicates the rear axle ratio of the vehicle.	2.00 to 19.99
TOP GEAR RATIO	Indicates the vehicle transmission final drive ratio.	0.5 to 2.55

Table 3-58 Vehicle Speed Sensor Parameters

Magnetic Pickup

The magnetic pickup requirements are listed in Table 3-59. Magnetic Pickup size is determined by installation requirements. Both circuits 556 and 557 must be used.

Parameters	Range
Input Frequency Range	1 - 3000 Hz
Input Amplitude Range	800 mV — 100 V peak to peak

Table 3-59 Magnetic Pickup Vehicle Speed Sensor Requirements

See Figure 3-92 for the installation of magnetic pickup VSS.

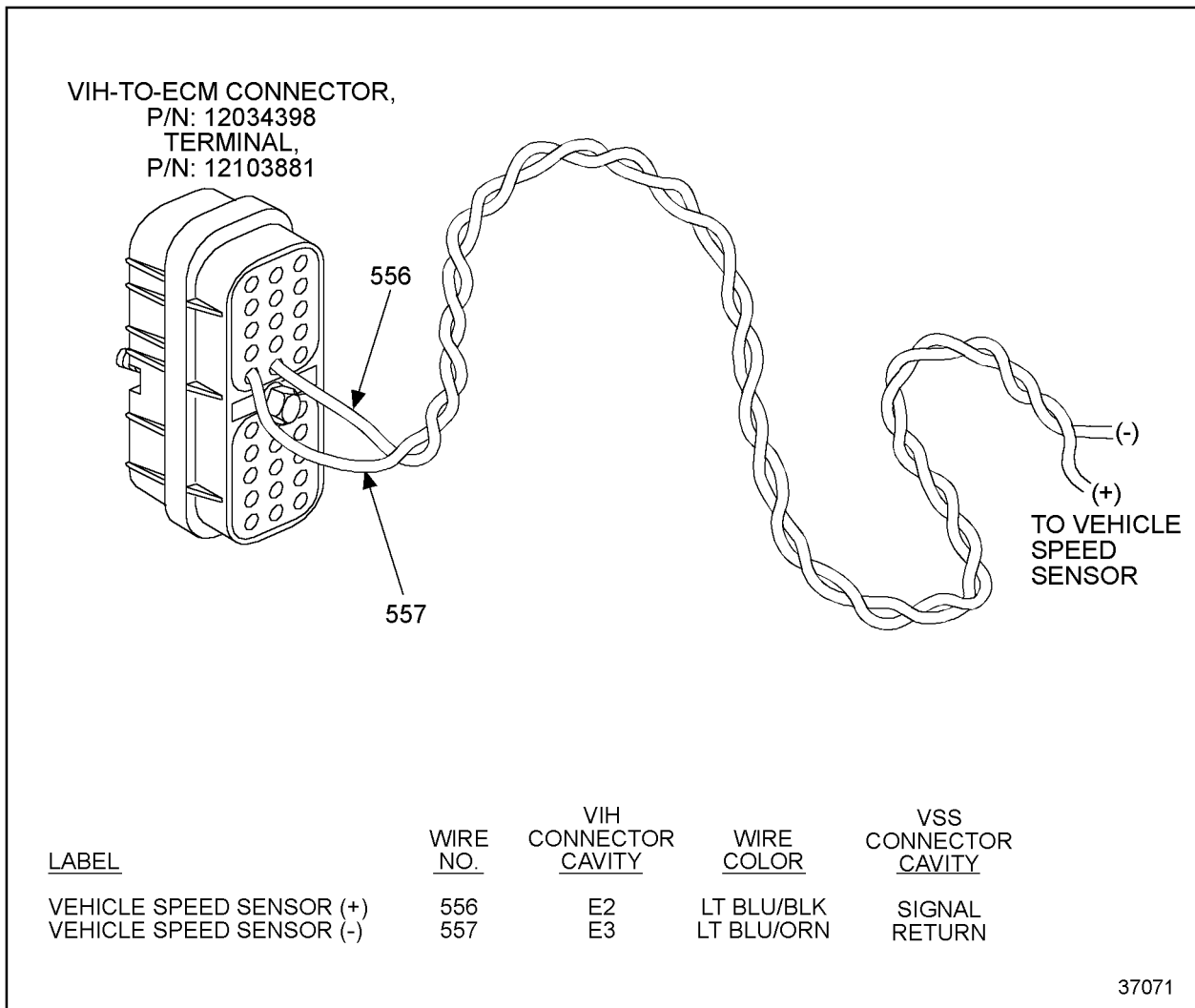

Figure 3-92 Magnetic Pickup Vehicle Speed Sensor Installation

Magnetic Vehicle Speed Sensors can be obtained from the following sources:

Wabash Technologies

1375 Swan Street
Huntington, Indiana
46750-0829

Tel: 260-356-8300

www.wabashtech.com

Airpax Instruments

150 Knotter Drive
Cheshire, Connecticut 06410

Tel: 800-643-0643

**Invensys Electro
Corporation**

1845 57th Street
Sarasota, Florida 34231

Tel: 1-800-446-5762

Fax: 941-355-3120

www.electrocorp.com

Open Collector

The open collector input is defined as a single wire input that alternates between a high voltage of at least 4 V DC and a low voltage of 1.0 V DC or less. Typically, the input is connected to a transistor collector output whether open or through a pull up resistor. A pull up resistor is preferred as this eliminates the need to configure the signal type as open collector. See Figure 3-93 for open collector VSS installation.

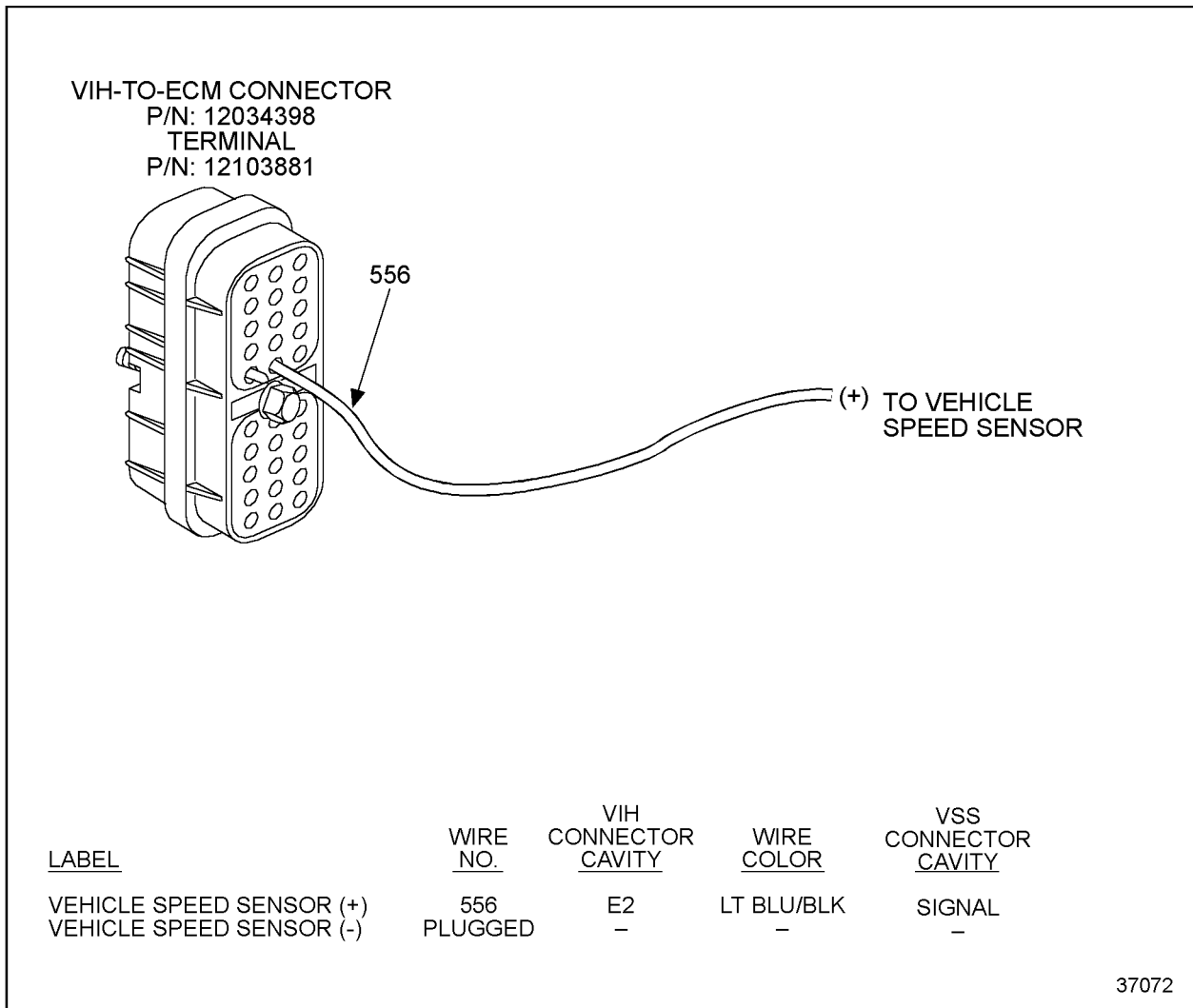

Figure 3-93 Open Collector Vehicle Speed Sensor Installation

Allison Transmission Electronic Controls have an open collector output. DDEC IV circuit #556 is connected to Allison circuit #205 (Allison Transmission Electronic Controls) or Allison circuit #157 (World Transmission). This device is an electrically operated switch that grounds or opens the input signal. The VSS frequency (pulses/mile) may range between 7,000 and 145,000 pulses/mile.

The open collector requirements are listed in Table 3-60. Only circuit 556 is used. 557 cavity must be empty.

Parameters	Range
High State	$4.0 < E_{in} < \text{Battery (+)}$ with $I_{leakage} < 0.2\text{mA}$
Peak to Peak Voltage Maximum	$-2.0 < E_{in} < 1.0 \text{ V}$ while $I_{source} < 5.0\text{mA}$
Input Frequency Range	1 - 3000 Hz

Table 3-60 Open Collector Vehicle Speed Sensor Requirements

SAE J1939 Data Link

A VSS wired to the ECM is not required if the transmission output shaft speed message is being transmitted over the SAE J1939 Data Link. To obtain accurate vehicle mileage, the parameters listed in Table 3-61 must be programmed with the DDR, DDDL, VEPS, DRS, or at order entry. The VSS type will automatically be set to SAE J1939 when the appropriate transmission type is selected (trans type = 16).

Parameter	Description	Choice / Display
VSS ENABLED	Enables or disables the vehicle speed sensor input.	YES, NO
VSS TYPE	Type of vehicle speed sensor used	J1939
TIRE REVS/MI or REV/KM	Vehicle tire revolutions per mile.	100 to 999
AXLE RATIO	Indicates the rear axle ratio of the vehicle.	2.00 to 19.99
TOP GEAR RATIO	Indicates the vehicle transmission final drive ratio.	0.5 to 2.55

Table 3-61 Vehicle Mileage Parameters

Two faults (SID 216 FMI 14 and PID 84 FMI 12) will be logged simultaneously if DDEC is calibrated to receive output shaft speed over a SAE J1939 Data Link and the data is not being received or the data is bad. This indicates that there is a problem with the sensor on the transmission or the transmission controller. If these faults are received in addition to a SAE J1939 Data Link failure (SID 231, FMI 12), then the problem is with the SAE J1939 Data Link itself.

VSS Anti-Tamper

If the sensor appears to be working improperly but the vehicle speed is not zero, VSS Anti-Tamper logs a VSS fault. The engine speed in all gears will be limited for the duration of the ignition cycle to the engine speed at the Vehicle Speed Limit in top gear. Refer to section 5.28 for more information on VSS Anti Tamper.

3.14.26 AFTERMARKET INSTALLED SENSORS

One sensor, the Exhaust Back Pressure Sensor, is installed aftermarket.

Exhaust Back Pressure Sensor

The Exhaust Back Pressure Sensor Kit components, used in conjunction with aftertreatment systems, provides diagnostic capability and engine protection in the event of excessive exhaust backpressure. This kit is required for Emitless particulate filter installations. It may be used as an option with catalytic converter installations.

For applications that use the Service Now Lamp, the dash light (CEL) will illuminate for all diagnostic faults EXCEPT for Exhaust Back Pressure High (PID 81, FMI 0). The light in the engine compartment will illuminate for ALL faults. The Exhaust Back Pressure High fault will latch active over ignition cycles, which will keep the engine compartment light on. This fault can be cleared with a DDR or DDDL (6.0 or later).

If the Exhaust Back Pressure fault is not addressed within 50 engine hours, the dash light will turn on and a Service Now Lamp Expired fault (SID 151, FMI 11) will be logged.

For installation requirements of the SNL, refer to section 3.16.3, "Service Now Lamp."

De-greening Process for Particulate Trap Filters

The "de-greening" process for a particulate trap filter begins upon an installation of a new filter on an engine. The feature is automatically enabled when the Exhaust Back Pressure Sensor (PID 81) is configured on an analog input. This is available with Rel 38.0 or later.

When a new particulate trap filter is installed (which requires the filter to go through the de-greening process), the exhaust back pressure limit for triggering of the excessive exhaust back pressure faults is increased. This increased threshold is applied for the first 4000 vehicle miles since the new particulate trap filter installation.

A "reset" to indicate that the particulate trap filter has been installed and that the de-greening process has started is indicated in one of the following two ways:

- With ignition on but the engine not running, press hard on the throttle foot pedal five times within five seconds.
- By using DDDL (Rel 6.2 or later) or DRS (rel 5.1 or later).

A user can recognize a successful reset based on the fact that CEL/SNL flashes for five seconds after the reset action has completed. At the point of the reset, DDEC stores the current total vehicle miles accumulated across ignition cycles.

Exhaust Back Pressure Sensor Installation

The Exhaust Back Pressure Sensor comes in the Exhaust Back Pressure Sensor Kit. This kit is intended for installation on Detroit Diesel Series 50 Diesel Bus/Coach engines with DDEC IV. See Figure 3-94.

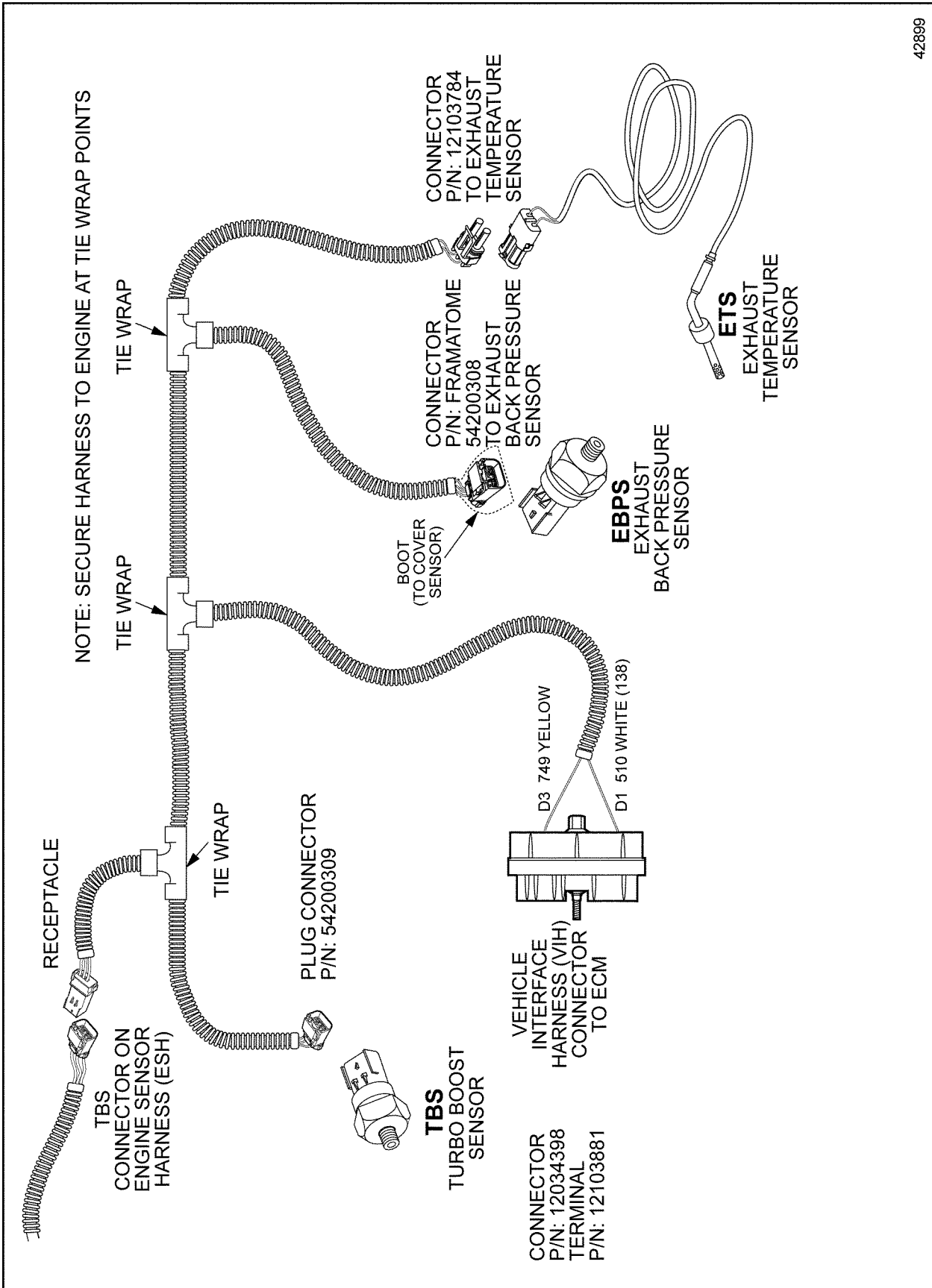

Figure 3-94 Exhaust Temperature and Pressure Sensor Harness

Three service kits with different length sensor harnesses are available. The parts to the three kits are listed in Table 3-62, Table 3-63, and Table 3-64.

NOTE:

Kits are assembled without an Exhaust Temperature Sensor to accommodate customers retrofitting engines have sensor P/N: 23521882 (with 182 cm/72 in. cable) previously installed. If an Exhaust Temperature Sensor was not previously installed, obtain one from an authorized Detroit Diesel distributor.

Part Number	Quantity	Description
23531079	1	Exhaust Temperature/Pressure Harness, 589 cm/232 in. in Length
23528948	1	Exhaust Back Pressure Sensor
23529151	1	Stainless Steel Braided hose, 91 cm/36 in. in Length
23529152	1	Sensor Mounting Bracket
23529150	1	Bulkhead Compression Fitting with Female 3/8 in. NPTF Pipe Thread
23528903	1	Compression Fitting with Weld End
11505299	2	Bolt, M10 X 1.5 X 30 (Flange Head)
11506101	2	Nut, M10 X 1.5 (Flange Head)
18SP561	1	Installation Instructions

Kits do not include an Exhaust Temperature Sensor

Table 3-62 Exhaust Back Pressure Sensor Kit with 589 cm/232 in. Harness, P/N: 23531230

Part Number	Quantity	Description
23531078	1	Exhaust Temperature/Pressure Harness 432 cm/170 in. Length
23528948	1	Exhaust Back Pressure Sensor
23529151	1	Stainless Steel Braided hose, 91 cm/36 in. Length
23529152	1	Sensor Mounting Bracket
23529150	1	Bulkhead Compression Fitting with Female 3/8 in. NPTF Pipe Thread
23528903	1	Compression Fitting with Weld End
11505299	2	Bolt, M10 X 1.5 X 30 (Flange Head)
11506101	2	Nut, M10 X 1.5 (Flange Head)
18SP561	1	Installation Instructions

Kits do not include an Exhaust Temperature Sensor

Table 3-63 Exhaust Back Pressure Sensor Kit with 432 cm/170 in. Length Harness, P/N: 23531231

Part Number	Quantity	Description
23531077	1	Exhaust temperature/Pressure Harness, 254 cm/100 in. Length
23528948	1	Exhaust Back Pressure Sensor
23529151	1	Stainless Steel Braided hose, 91 cm/36 in. Length
23529152	1	Sensor Mounting Bracket
23529150	1	Bulkhead Compression Fitting with Female 3/8 in. NPTF Pipe Thread
23528903	1	Compression Fitting with Weld End
11505299	2	Bolt, M10 X 1.5 X 30 (Flange Head)
11506101	2	Nut, M10 X 1.5 (Flange Head)
18SP561	1	Installation Instructions

Kits do not include an Exhaust Temperature Sensor

Table 3-64 Exhaust Back Pressure Sensor Kit with 254 cm/100 in. Length Harness P/N: 23531232

3.15 THROTTLE DEVICES

There are several types of throttle controls which may be used for engine control.

- Hand throttle
- Electronic Foot Pedal Assembly (EFPA)
- Cruise Control switches
- Fast Idle Switch
- Voltage dividers
- Frequency input

The throttle input device is OEM-supplied.

There are two types of engine governors that are used with throttle controls. The engine governors are:

- The Limiting Speed Governor (LSG) for torque control
- The Variable Speed Governor (VSG) for speed control

3.15.1 ELECTRONIC FOOT PEDAL ASSEMBLY

The EFPA contains the Throttle Position Sensor (TPS) which converts the operator's hand throttle and/or foot pedal input into a signal for the ECM. The EFPA and the TPS are shown in Figure 3-95.

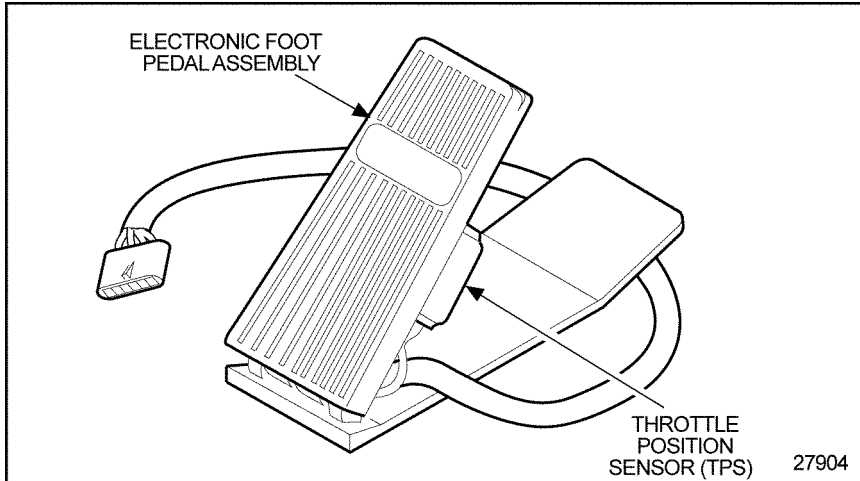

Figure 3-95 Typical EFPA Throttle Device (Shown with 6-pin Connector)

The EFPA sends the ECM an input signal which controls engine power on the LSG, proportional to the foot pedal position. This assembly is also referred to as the Throttle Position Sensor (TPS) assembly.

The system fault detection diagnostics will return the engine to idle speed in the event of a sensor or associated wiring malfunction. The fault detection diagnostics work with or without an idle validation switch on the EFPA. An idle validation switch provides redundancy to assure that the engine will be at idle in the event of an in-range malfunction. The connectors for the TPS are Weather Pack push-to-seat connectors and are listed in Table 3-65.

Throttle Position Sensor Harness Side		Throttle Position Sensor on the Sensor Side	
Connector	P/N: 12015793	Connector	P/N: 12010717
Terminal	P/N: 12089188	Terminal	P/N: 12034051
Seal	P/N: 12015323	Seal	P/N: 12015323

Table 3-65 Connectors for the Throttle Position Sensor

The EFPA can be used with both LSG and VSG.

3.15.2 CRUISE CONTROL SWITCHES

The Cruise Control switches can be used to control the VSG set speed. This feature is referred to as Cruise Switch VSG. For more information on Cruise Switch VSG, refer to section 5.3.3 and section 5.24.2.

3.15.3 HAND THROTTLE

A hand throttle (potentiometer) may be used to control engine speed on the VSG between the minimum and maximum VSG speed. The total resistance must be between 1k Ω and 10 k Ω .

When active, the hand throttle will control the engine speed on the VSG between the VSG minimum speed and the VSG maximum speed. For more information on the hand throttle, refer to section 5.24.2.

3.15.4 FAST IDLE SWITCH (ALTERNATE MINIMUM VSG)

The Alternate Minimum VSG option allows a customer to select an alternate idle speed when its digital input is switched to battery ground.

For more information on Alternate Minimum VSG/Fast Idle, refer to section 5.24.2.

3.15.5 VOLTAGE DIVIDERS

Voltage dividers can be used with the VSG input to provide a means to select a predetermined engine speed. Voltage dividers can be used to provide a fast idle operation or other engine operations where a fixed engine speed is desired.

For more information on voltage dividers, refer to section 5.24.2.

3.16 LIGHTS

The instrument panel warning lights, the Check Engine Light (CEL) and the Stop Engine Light (SEL), are supplied by the OEM. The functionality of each light along with the wiring requirements are covered separately in the following sections.

3.16.1 CHECK ENGINE LIGHT

The CEL is controlled by the DDEC ECM. The CEL remains ON:

- For approximately five (5) seconds at the start of every ignition cycle (a bulb check)
- When an electronic system fault occurs (This indicates the problem should be diagnosed as soon as possible.)

The CEL flashes:

- When the Diagnostic Request Switch is used to activate the CEL to flash inactive codes
- During last 90 seconds before Idle Shutdown if programmed for override
- When Idle Shutdown occurs or the Optimized Idle system shutdown occurs

The CEL is active with the PasSmart feature. When the Passing Speed Duration time expires, the CEL will begin to flash one minute prior to ramping the Vehicle Limit Speed (VLS) down to the normal limit. The rampdown event always takes five seconds regardless of the Passing Speed Increment programmed into the ECM. The rampdown alert can be distinguished from an engine fault warning in that the CEL flashes for the former and remains on constantly for the latter.

PasSmart still operates when there is an active engine fault. In this situation, the CEL goes from constant illumination to flashing one minute before rampdown from the VSL. At the end of the passing event when PasSmart is deactivated, the CEL returns to constant illumination if the engine fault is still active.

The CEL is also active with the DDEC Reports Periodic Maintenance Intervals. If a maintenance interval is within a specified percentage of expiration (default is 20%), the CEL flashes six times when the ignition is turned on. The ignition must have been off for less than 30 seconds prior to being turned on. If the off time has been greater than 30 seconds, no indication of maintenance interval status is given.

Check Engine Light Requirements and Guidelines

The following requirements and guidelines apply to the CEL:

- The CEL must be supplied by the OEM.
- A 12 or 24 volt light of less than 1.5 A (DC) is required depending on the ignition source. Digital output circuits are designed to sink no more than 1.5 A (DC) current and have less than 85 mH of inductance. A low-side digital output sinks 60 μ A when OFF.
- The CEL must be integrated into the instrument panel or placed in clear view of the equipment operator.
- The lens color must be amber.
- The words CHECK ENGINE must appear on or near the CEL lamp.

Check Engine Light Wiring

The CEL is connected to wire 419 in the VIH. See Figure 3-96 for the recommended CEL wiring.

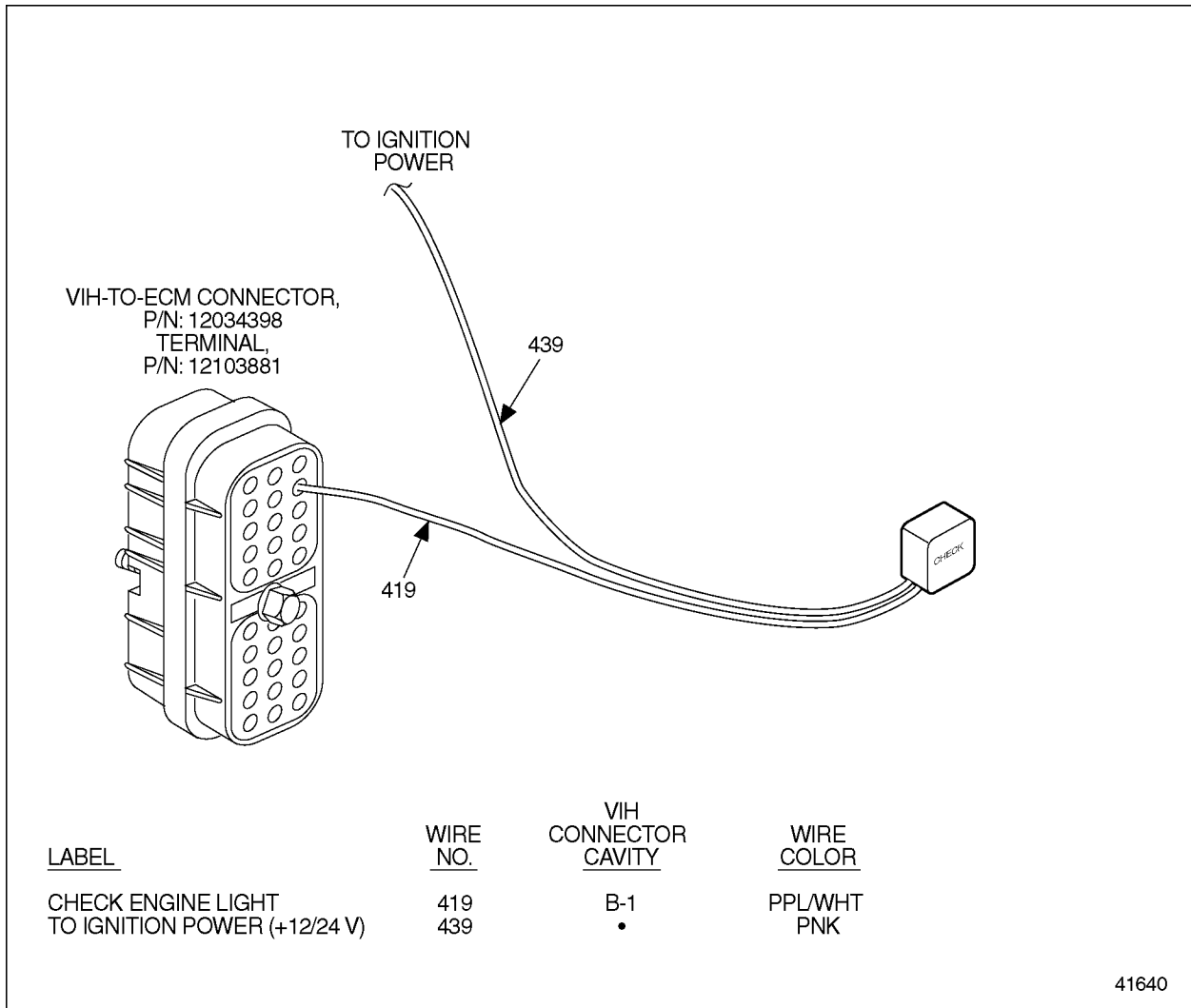

Figure 3-96 Check Engine Light Wiring

3.16.2 STOP ENGINE LIGHT

The SEL is controlled by the DDEC ECM. The SEL remains ON:

- For approximately five (5) seconds at the start of every ignition cycle (a bulb check)
- When a potentially engine damaging fault is detected

The SEL flashes:

- After Engine Protection Shutdown occurs
- When the Diagnostic Request Switch is used to activate the SEL to flash active codes

Stop Engine Light Requirements and Guidelines

The following requirements and guidelines apply to the SEL:

- The SEL must be incorporated into the VIH by the OEM.
- A 12 or 24 volt light of less than 1.5 A (DC) is required depending on the ignition source. Digital output circuits are designed to sink no more than 1.5 A (DC) current and have less than 85 mH of inductance. A low-side digital output sinks 60 μ A when OFF.
- The SEL must be integrated into the instrument panel or placed in clear view of the equipment operator.
- The lens color must be red.
- The words STOP ENGINE must appear on or near the SEL lamp.

Stop Engine Light Wiring

See Figure 3-97 for the recommended SEL wiring.

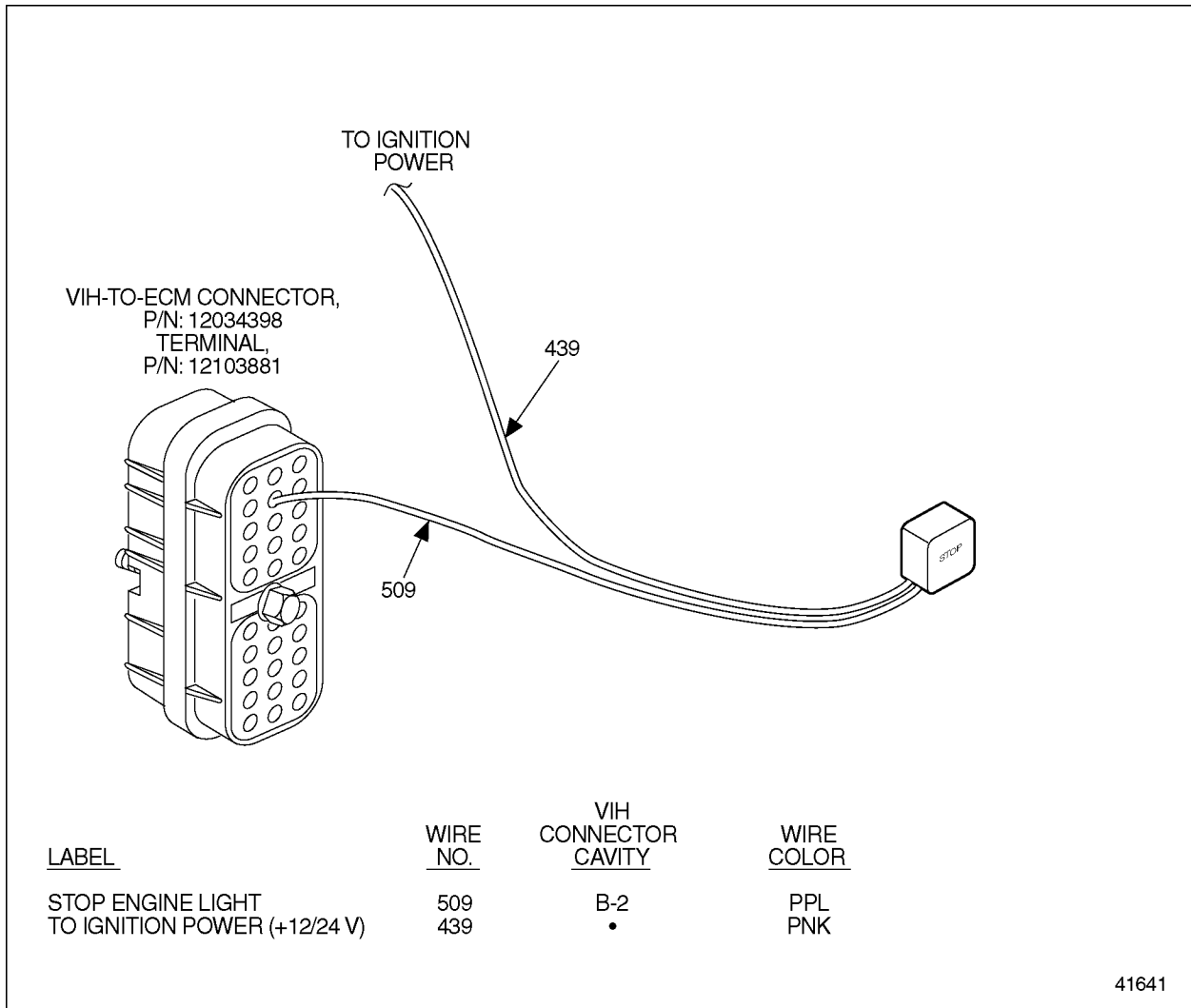

Figure 3-97 Stop Engine Light Wiring

3.16.3 SERVICE NOW LAMP

The Service Now Lamp (SNL) is available for Series 50 bus applications that have an Exhaust Back Pressure Sensor installed.

The dash light (CEL) will turn on for all diagnostic faults EXCEPT for Exhaust Back Pressure High (PID 81, FMI 0). The light in the engine compartment will turn on for ALL faults. The Exhaust Back Pressure High fault will latch active over ignition cycles, which will keep the engine compartment light on. This fault can be cleared with a DDR or DDDL (6.0 or later).

The SNL function must be configured on pin F3.

This feature is available with Rel 36.01 or later.

Installation

For new **OEM installations**, a light will be installed in the engine compartment and will be wired to the CEL circuit (pin B1). Another light (programmed as SNL) will be installed on the dash and wired to pin F3.

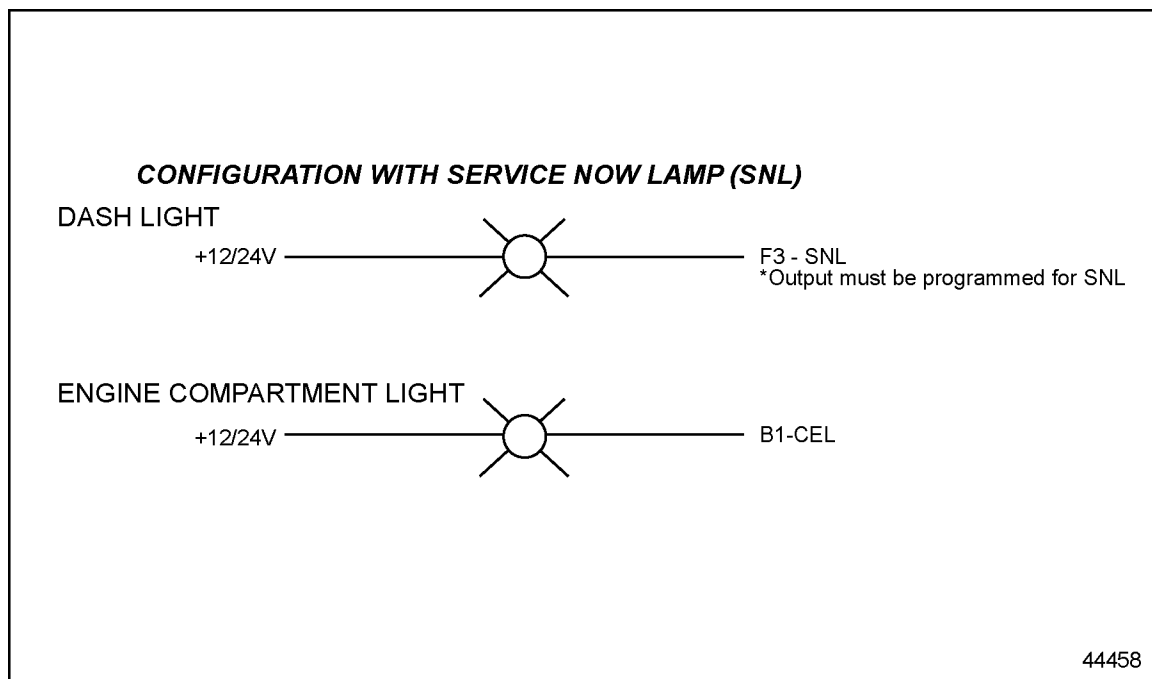

Figure 3-98 OEM Installation of the Service Now Lamp

For **Aftermarket installations**, the CEL on the dash must be rewired to pin F3. A new light must be installed in the engine compartment and wired to pin B1 - CEL. See Figure 3-99.

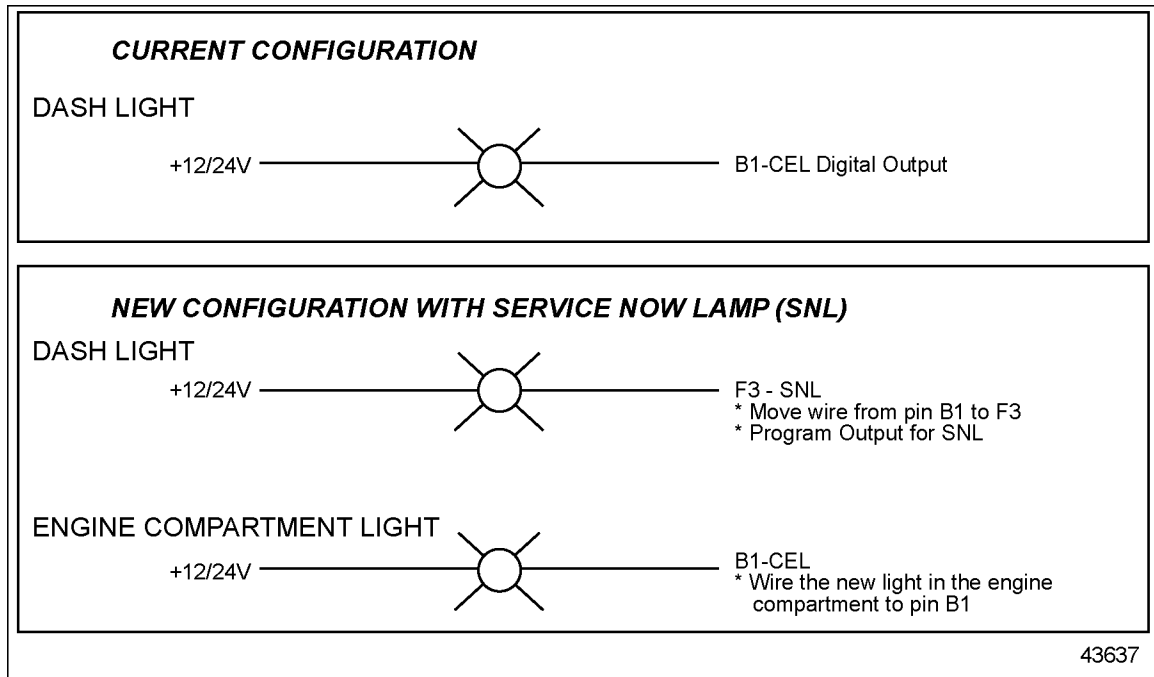

Figure 3-99 **Aftermarket Installation of the Service Now Lamp**

THIS PAGE INTENTIONALLY LEFT BLANK