

### 18-PIN CONNECTOR #1

- 1/1 TWO-SPEED AXLE
- 1/2 PARK BRAKE INTERLOCK
- 1/3 IDLE VALIDATION SWITCH 2 (THROTTLE ACTIVE)
- 1/4 THROTTLE POSITION SENSOR GND
- 1/5 DPF REGENERATION LAMP
- 1/6 IDLE VALIDATION SWITCH 1 (IDLE ACTIVE)
- 1/7 THROTTLE POSITION SENSOR
- 1/8 THROTTLE POSITION SENSOR SUPPLY
- 1/9 TACHOMETER
- 1/10 STOP ENGINE / AUX SHUTDOWN #1
- 1/11 LIMITER 0 / LIMITING TORQUE CURVE
- 1/12 SET / COAST ENABLE
- 1/13 MIL LAMP
- 1/14 CRUISE CONTROL ENABLE
- 1/15 STOP ENGINE OVERRIDE / DIAGNOSTIC REQUEST
- 1/16 RESUME / ACCEL ENABLE
- 1/17 SPARE
- 1/18 RUN START

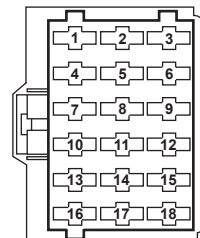

**WHITE - FRONT**  
LOOKING INTO PINS  
ON THE HARNESS

### 18-PIN CONNECTOR #2

- 2/1 MAIN BATTERY (+12V)
- 2/2 MAIN BATTERY GROUND
- 2/3 IGNITION
- 2/4 K-LINE
- 2/5 J1587+
- 2/6 J1587-
- 2/7 SERVICE BRAKE RELEASED SWITCH
- 2/8 REMOTE THROTTLE SELECT SWITCH
- 2/9 REMOTE PTO SWITCH
- 2/10 AMBER WARNING LAMP
- 2/11 LIM 1 / FAST IDLE / ALT ROAD SPEED LIMIT / ALT ETC
- 2/12 A/C STATUS
- 2/13 FAN OVERRIDE
- 2/14 ENGINE BRAKE LOW
- 2/15 ENGINE BRAKE MEDIUM
- 2/16 J1939-
- 2/17 J1939 SHIELD
- 2/18 J1939+

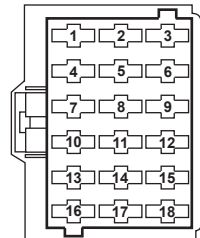

**GRAY - FRONT**  
LOOKING INTO PINS  
ON THE HARNESS

### 21-PIN CONNECTOR #3

- 3/1 OI THERMOSTAT
- 3/2 SENSOR RETURN
- 3/3 SENSOR SUPPLY
- 3/4 REMOTE PTO
- 3/5 SPARE
- 3/6 SPARE
- 3/7 TOP 2 LOCKOUT SOLENOID
- 3/8 TOP 2 SHIFT SOLENOID
- 3/9 AGS 2 BACKUP LAMP
- 3/10 AGS 2 TRANS TEMP LAMP
- 3/11 LOW COOLANT LEVEL SENSOR
- 3/12 AGS 2 CHECK TRANS LAMP
- 3/13 VEHICLE SPEED (+)
- 3/14 VEHICLE SPEED (-)
- 3/15 AMBIENT AIR TEMPERATURE SENSOR
- 3/16 RED STOP LAMP
- 3/17 OI ALARM
- 3/18 ABS ACTIVE (AGS 2 TRANS)
- 3/19 NOT USED
- 3/20 NOT USED
- 3/21 NOT USED

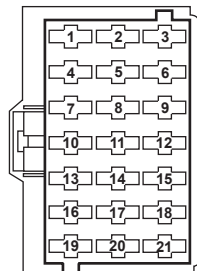

**BROWN FRONT**  
LOOKING INTO PINS  
ON THE HARNESS

### 18-PIN CONNECTOR #4

- 4/1 ENGINE CAN (-)
- 4/2 ENGINE CAN SHIELD
- 4/3 ENGINE CAN (+)
- 4/4 SPARE
- 4/5 SPARE
- 4/6 WAIT TO START LAMP (GRID HEATER)
- 4/7 HIGH EXHAUST SYSTEM TEMP LAMP
- 4/8 CLUTCH RELEASED
- 4/9 OI ACTIVE LAMP
- 4/10 VEHICLE POWER SHUTDOWN
- 4/11 SPARE
- 4/12 VEHICLE SPEED OUTPUT
- 4/13 SPARE
- 4/14 SPARE
- 4/15 SPARE
- 4/16 NEUTRAL SWITCH
- 4/17 REGEN SWITCH
- 4/18 HOOD TILT SWITCH

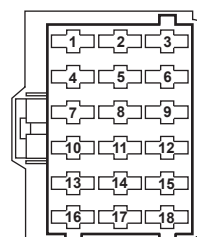

**BLUE FRONT**  
LOOKING INTO PINS  
ON THE HARNESS

### CONNECTS TO ENGINE HARNESS 31-PIN CONNECTOR

CAVITY	LABEL	ENGINE SERIES
1	SPARE	
2	POWER SUPPLY - IGN	HDE
3	FUEL HEATER SUPPLY (+) #1	MBE 900, HDE
4	SPARE	
5	FUEL HEATER SUPPLY #2	MBE 900, HDE
6	SPARE	
7	POWER SUPPLY - GND	HDE
8	ETHER START	S60
9	VARIABLE SPEED FAN CONTROL OR HIGH OF 2-SPEED FAN	ALL
10	SINGLE SPEED FAN CONTROL OR LOW OF 2-SPEED FAN	ALL
11	FUEL HEATER GROUND #1	MBE 900, HDE
12	SPARE	
13	SPARE	
14	WATER-IN-FUEL SENSOR SUPPLY	MBE 900
15	WATER-IN-FUEL SENSOR GROUND	MBE 900
16	ENGINE BRAKE SOLENOID CONTROL	MBE 900
17	DOC OUTLET TEMPERATURE SENSOR	ALL
18	DOC INLET TEMPERATURE SENSOR	ALL
19	DPF OUTLET TEMPERATURE SENSOR	ALL
20	FUEL HEATER GROUND #2	MBE 900, HDE
21	SPARE	
22	POWER SUPPLY - ENG. BRAKE, FAN, ETHER	ALL
23	FAN SPEED	ALL
24	SENSOR GROUND	ALL
25	SPARE	
26	WATER-IN-FUEL SENSOR	MBE 900
27	TCI TEMP.	S60
28	SENSOR GROUND	ALL
29	SENSOR SUPPLY	ALL
30	DPF OUTLET PRESSURE SENSOR	ALL
31	DPF INLET PRESSURE SENSOR	ALL

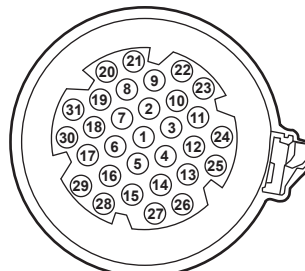

**FRONT**  
LOOKING INTO PINS  
ON THE HARNESS

TO 10-PIN DPF CONNECTOR  
CONNECTOR P/N: 54201016  
TERMINAL P/N: LSP-1811-58AU  
PLUG: P/N: 54200005

### GOVERNOR

#### THROTTLE PEDAL

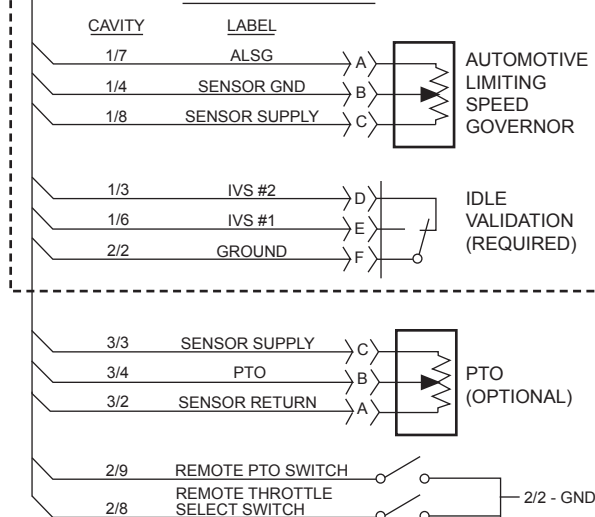

### CRUISE CONTROL

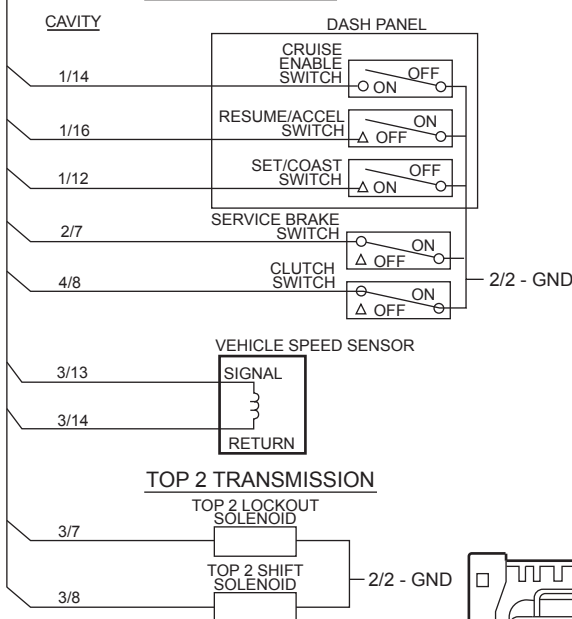

### ENGINE COOLANT LEVEL SENSOR - SHUTDOWN

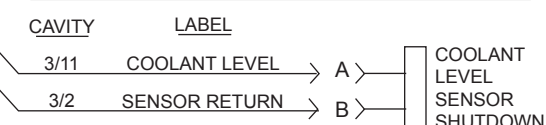

### DIAGNOSTIC CONNECTOR - REQUIRED

CAVITY	DDC CONNECTOR	LABEL
-	A	GND
-	B	+12 V
2/18	C	J1939 DATA LINK (+)
2/16	D	J1939 DATA LINK (-)
2/17	E	J1939 SHIELD
2/5	F	J1587 DATA LINK (+)
2/6	G	J1587 DATA LINK (-)
-	H	PLUG
-	J	PLUG

### OEM-MCM 21-PIN CONNECTOR

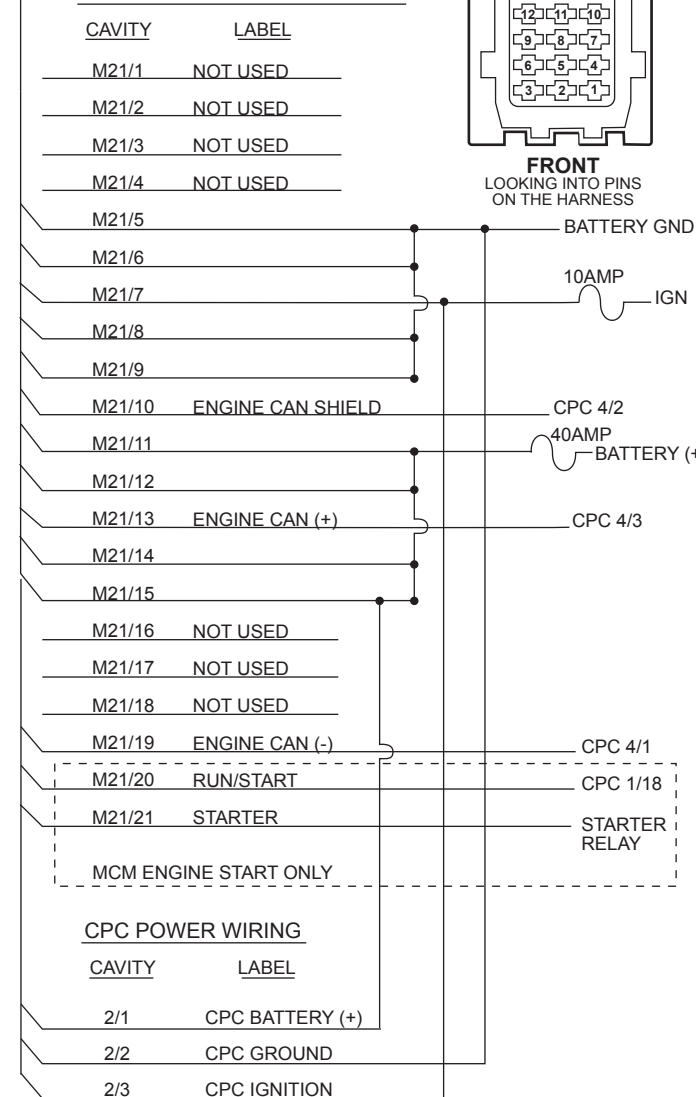

### INSTRUMENT PANEL

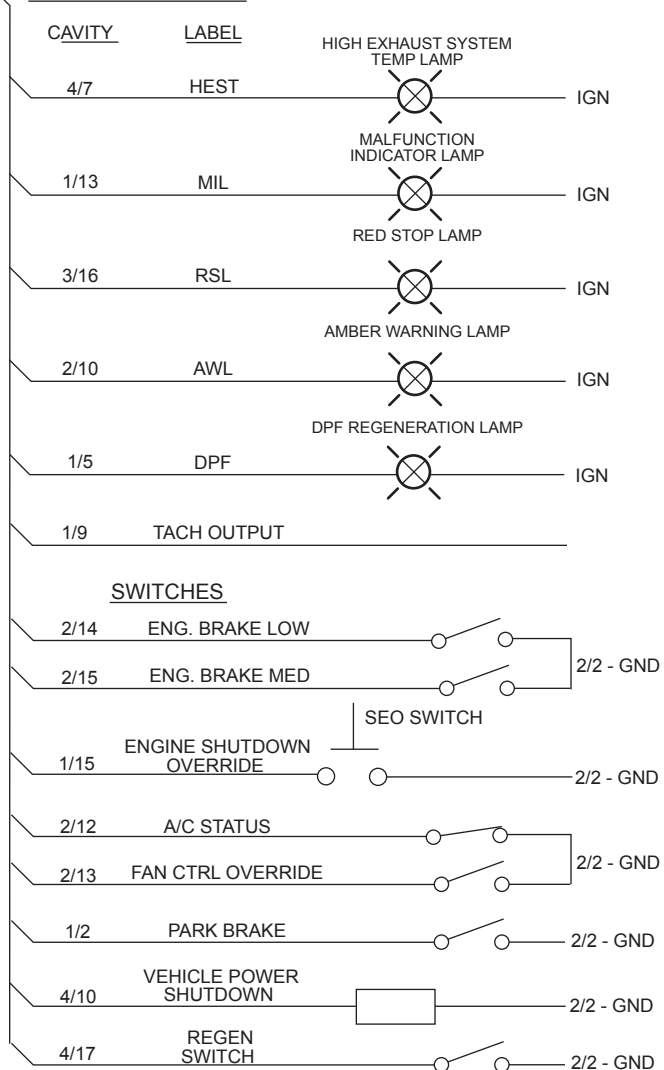

# DDEC VI (CPC) VEHICLE INTERFACE HARNESS