

Technical Publication

Diesel Engine
8V2000C
8V2000G

Maintenance
Manual
M020084/00E



Printed in Germany

© 2003 Copyright MTU Friedrichshafen GmbH

Diese Veröffentlichung einschließlich aller seiner Teile ist urheberrechtlich geschützt. Jede Verwertung oder Nutzung bedarf der vorherigen schriftlichen Zustimmung der MTU Friedrichshafen GmbH. Das gilt insbesondere für Vervielfältigung, Verbreitung, Bearbeitung, Übersetzung, Mikroverfilmungen und die Einspeicherung und / oder Verarbeitung in elektronischen Systemen, einschließlich Datenbanken und Online-Diensten.

Das Handbuch ist zur Vermeidung von Störungen oder Schäden beim Betrieb zu beachten und daher vom Betreiber dem jeweiligen Wartungs- und Bedienungspersonal zur Verfügung zu stellen.

Änderungen bleiben vorbehalten.

Printed in Germany

© 2003 Copyright MTU Friedrichshafen GmbH

This Publication is protected by copyright and may not be used in any way whether in whole or in part without the prior written permission of MTU Friedrichshafen GmbH. This restriction also applies to copyright, distribution, translation, microfilming and storage or processing on electronic systems including data bases and online services.

This handbook is provided for use by maintenance and operating personnel in order to avoid malfunctions or damage during operation.

Subject to alterations and amendments.

Imprimé en Allemagne

© 2003 Copyright MTU Friedrichshafen GmbH

Tout droit réservé pour cet ouvrage dans son intégralité. Toute utilisation ou exploitation requiert au préalable l'accord écrit de MTU Friedrichshafen GmbH. Ceci s'applique notamment à la reproduction, la diffusion, la modification, la traduction, l'archivage sur microfiches, la mémorisation et / ou le traitement sur des systèmes électroniques, y compris les bases de données et les services en ligne.

Le manuel devra être observé en vue d'éviter des incidents ou des endommagements pendant le service. Aussi recommandons-nous à l'exploitant de le mettre à la disposition du personnel chargé de l'entretien et de la conduite.

Modifications réservées.

Impreso en Alemania

© 2003 Copyright MTU Friedrichshafen GmbH

Esta publicación se encuentra protegida, en toda su extensión, por los derechos de autor. Cualquier utilización de la misma, así como su reproducción, difusión, transformación, traducción, microfilmación, grabación y/o procesamiento en sistemas electrónicos, entre los que se incluyen bancos de datos y servicios en línea, precisa de la autorización previa de MTU Friedrichshafen GmbH.

El manual debe tenerse presente para evitar fallos o daños durante el servicio, y, por dicho motivo, el usuario debe ponerlo a disposición del personal de mantenimiento y de servicio.

Nos reservamos el derecho de introducir modificaciones.

Stampato in Germania

© 2003 Copyright MTU Friedrichshafen GmbH

Questa pubblicazione è protetta dal diritto d'autore in tutte le sue parti. Ciascun impiego od utilizzo, con particolare riguardo alla riproduzione, alla diffusione, alla modifica, alla traduzione, all'archiviazione in microfilm ed alla memorizzazione od all'elaborazione in sistemi elettronici, comprese banche dati e servizi on line, deve essere espressamente autorizzato per iscritto dalla MTU Friedrichshafen GmbH.

Il manuale va consultato per evitare anomalie o guasti durante il servizio, per cui va messo a disposizione dall'utente al personale addetto alla manutenzione e alla condotta.

Con riserva di modifiche.

Printed in Germany

© 2003 Copyright MTU Friedrichshafen GmbH

A presente publicação, inclusive todas as suas partes, está protegida pelo direito autoral. Qualquer aproveitamento ou uso exige a autorização prévia e por escrito da MTU Friedrichshafen GmbH.

Isto diz respeito em particular à reprodução, divulgação, tratamento, tradução, microfilmagem, e a memorização e/ou processamento em sistemas eletrônicos, inclusive bancos de dados e serviços on-line.

Para evitar falhas ou danos durante a operação, os dizeres do manual devem ser respeitados. Quem explora o equipamento economicamente consequentemente deve colocá-lo à disposição do respetivo pessoal da conservação, e à disposição dos operadores.

Salvo alterações.

Amendment Service!

Any changes in contents will be sent to you in the form of an amendment, provided you complete the reverse of this receipt card and return it to us.

M020084/00E
Maintenance Manual
8V 2000 C 8V2000 G

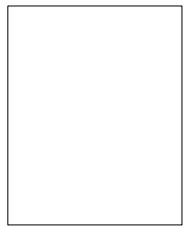

Postcard

MTU Friedrichshafen GmbH
Department SCT
88040 Friedrichshafen
GERMANY

Please mark all filed amendments here.



No.	Date	Name
1.	99-02	Schön
2.	00-08	
3.		
4.		
5.		
6.		
7.		
8.		
9.		
10.		
11.		
12.		
13.		
14.		
15.		
16.		

Please use block capitals!



Receipt	Amendment No.	1.	99-02
<input type="checkbox"/> Update as (PDF) file by E-mail		2.	00-08
<input type="checkbox"/> Update as (PDF) file as CD-ROM		3.	
<input type="checkbox"/> Update in hardcopy form		4.	
Publication number: M020084/00E		5.	
Name		6.	
Manufacturer		7.	
Department E-mail		8.	
Fax Telephone		9.	
Street		10.	
Postal box number		11.	
(Postal code) City		12.	
Country		13.	
		14.	
		15.	
		16.	

General

- Important information
- Designation of engine sides
- Tightening specifications
- Settings
- Dangers in the work place
- Data sheets
- Conversion tables
- Publication summary
- Threaded bore repair
- Abbreviations
- Keyword index



Operation Schedules

- Check engine condition
- W5 Maintenance Operations
- Engine removal
- Engine disassembly
- Engine assembly
- Engine run-in
- Engine installation
- Engine drawings



Task Descriptions

- Group survey
- Materials and consumables
- Tools
- Component removal
- Component disassembly
- Inspection and repair
- Component assembly
- Component installation



Contents

A001	Important Information
A002	Designation of Engine Sides and Cylinders
A003	Torque Specifications for Screws and Nuts
A004	Settings
A005	Hazards in the Work Area
A006	Data Sheets
A007	Conversion Tables
A008	Publication Summary
A009	Repairing Threaded Bores
A080	Abbreviations
A090	Keyword Index

A001 Important Information

This manual is intended for use by technical personnel responsible for the **maintenance and servicing of the 2000 series diesel engine**.

This manual describes

- scheduled service operations from maintenance echelons W6 as well as
- non-scheduled service operations on the individual assemblies.

Index sheets divide this handbook into 3 main sections.

Section A	General
Section B	Work schedules
Section C	Task description

Section C is further subdivided into main function groups (MFG) and function groups (FG). The structure is oriented toward the logical structure of the parts list and Spare Parts Catalogues.

Intermediate index sheets bearing the MFG numbers subdivide Section C.

Each function group (FG) consists of no more than nine parts:

e.g.	C 011.05.01	General view
	C.011.0502	Special tool
	C.011.0504	Before-removal operations
	C.011.0505	Removal
	C.011.0506	Disassembly
	C.011.0508	Inspection and repair
	C.011.0510	Assembly
	C.011.0511	Installation
	C.011.0512	After-installation operations

Systematic searches for specific information and rapid orientation in the manual are supported by:

- The tables of contents on each main index sheet. They cross-reference the tables of contents of the individual groups.
An alphabetical subject index in Section A provides direct access to the individual Groups.
- The Group Summary at the start of Section C lists the individual main function groups (HFG).

Basic requirements for maintenance and service work

Customers performing their own maintenance must ensure that the following conditions and basic requirements are satisfied:

- all safety regulations are observed
- good general-purpose tools are provided
- cleaning and testing equipment is provided
- work is performed by trained personnel
- special tools are provided
- service area is adequately equipped

General Assembly Instructions

- Component cleanness:
Areas of all components that come in contact with oil, fuel, engine coolant and combustion air must be kept clean.
- Components requiring special cleanliness (e.g. oil- and fuel-carrying components) must be cleaned with suitable cleaning procedures before assembly, checked for particular cleanness and treated accordingly.
- Component packaging must only be removed immediately before installation.
- Elastomere components (e.g. rubber parts etc.) must not be washed with diesel fuel, solvents or cold cleaners. Parts dirtied with oil and fuel must be cleaned immediately. The parts should be wiped with a dry cloth. Elastomere components such as engine mounts, damping elements, couplings and V-belts must not be painted. They can only be installed after painting the engine or must be covered before painting work is carried out.
- Radial-lip shaft seals treated by the manufacturer with oil show as a result definite signs of swelling when delivered. They must therefore be cleaned (not washed) only with an abrasion-proof paper cloth before installation.
- The surfaces of parts that slide against each other must be lubricated with SAE30 engine oil when installed, unless otherwise specified.
- O-rings and surfaces moving against them during installation (bores and shafts) must be coated with petroleum jelly, unless otherwise specified.

When installing O-rings with counterrings in coolant pumps, always follow the installation instructions.

- After installing O-rings in shaft grooves, in order to remedy twists caused by installation, pass a rounded marking tool under the sealing ring in the direction of the circumference if the O-ring diameter is sufficiently large. Make sure that the O-ring is not damaged.
- Before shaft seal assembly:

On the shaft, the sealing lip of the shaft seal must be coated with petroleum jelly and the shaft running surface with thin-film lubricant or SAE30 engine oil.

In the support bore, the outer surface of metal outer jackets - unless otherwise specified in the drawing - must be coated with surface sealant. For elastomer outer jackets or combined metal/elastomer outer jackets, the outer surface must be coated with denaturated ethanol.

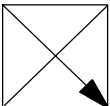

This symbol applies to radial-lip shaft seals and its significance depends on its position. The arrow indicates the position of the sealing lip.

- Sealing paste must be used to fix the position of flat gaskets. Sealing paste is to be thinly applied in spots on the flat gaskets or mating faces. Immediately after application of the sealing paste, the flat gaskets must be fitted to the component and then (no more than 20 minutes later) the seal components screwed together. Oil, multi-purpose grease or other materials must not be used to fix the position.
- Before installing antifriction bearings, lightly lubricate the bearing seats. Only remove the bearings from their original packaging immediately before installation so they do not get dirty. Do not remove the corrosion inhibitor from the bearings in original packaging. Use petroleum spirit or acid-free kerosene to clean the antifriction bearings. After cleaning, relubricate the bearings with engine oil.

During assembly, do not apply (axial) forces to antifriction elements and do not hit the bearing rings with a hammer (use assembly aids).
Do not use an open flame to heat bearing inner races.
The temperature should be between 80 °C and 100 °C and must never exceed 120 °C.

Deep-freezing for friction bearing installation is not permissible (risk of cracking, rusting through condensate).

- Dry bearings must not be oiled.
- When installing gears, the splines must be lubricated with SAE30 engine oil.
- All support and mating surfaces of components (e.g. mating surfaces for centring devices, flange and sealing surfaces, joint surfaces of press fits) must be clean, polished or provided with the specified surface protection and free from warping and damage. Corrosion inhibitors (e.g. oil, grease) must be removed from support and mating surfaces.
- After parts are joined which are installed by means of cooling using liquid nitrogen, all condensate must be removed and the parts coated with SAE30 engine oil.
- Sensors must be coated with long-life lubricant before installation in the immersion sleeves.
- Cable connections with cutting ring threaded connections must be installed in a vice and tightened, the thread first being coated with thin-film lubricant.
- If components are to be marked by etching, after the etching is completed the solution must be removed by means of neutralization agent. The affected parts must then be preserved with SAE30 engine oil.
- Components used in hot part areas (e.g. V-clamps, bellows, plug-in pipes, O-rings) must be coated at the support and mating surfaces with assembly paste, unless otherwise specified.
- The assembly surfaces of screws, nuts, washers and of parts to be tensioned must be clean and polished or provided with the specified surface protection and free from warping and damage. Corrosion inhibitors (e.g. oil, grease) must be removed. Threads and screw heads must be coated with lubricant before assembly as per tightening specifications.

Unless otherwise specified, the following lubricants should be used:

- SAE30 engine oil for general application
- Assembly paste in hot part areas.

a) Threaded connections without tightening specifications

For threaded connections without tightening specifications, the tightening procedure can be selected as required, i.e. mechanical tightening with screwdriver or normal manual tightening with an open-end wrench or box wrench is possible.

In the event of mechanical tightening, the tightening torque must be taken from the general tightening specifications according to thread size and property class.

b) Threaded connections with tightening specifications

- Torque tightening

The screw connections must be tightened by hand with a torque wrench or angle-of-rotation torque wrench.

The specified tightening torques must be set at the torque wrench without consideration of the specified tolerance. When using an angle-of-rotation torque wrench, the torque indicated must be within the torque specification limit value. Proceed in a similar manner with torsionally protected threaded connections. These instructions apply also to testing torque.

Note: If no tolerance for tightening torque is stated, the tightening tolerance is +10% of specified torque.

- Angle of rotation tightening:

The additional angles of rotation specified in the tightening specifications must be achieved and may be exceeded within the specified tolerance.

If no tightening tolerance is specified, the following tolerances must be observed:

- + 5° for angle of further rotation less than or equal to 90°
- + 10° for angle of further rotation greater than 90°

Before angle-of-rotation tightening, each screw head must be colour-marked so that after tightening it is possible to check that the angle of rotation is correct (exception: colour-marking is not necessary in the case of a self-monitoring NC screwdriver).

- Elongation tightening

Tightening must be carried out in accordance with tightening specifications taking the tightening tolerance into consideration.



A002 Designation of Engine Sides and Cylinders

Engine sides are always designated as viewed from the driving end.

Cylinders are designated (to DIN ISO 1204) A on the left engine side and B on the right engine side.

The cylinders of each bank are numbered in consecutive order, beginning at No. 1 at the driving end.

The consecutive numbering of other components, too, always begins with No. 1 at the driving end of the engine.

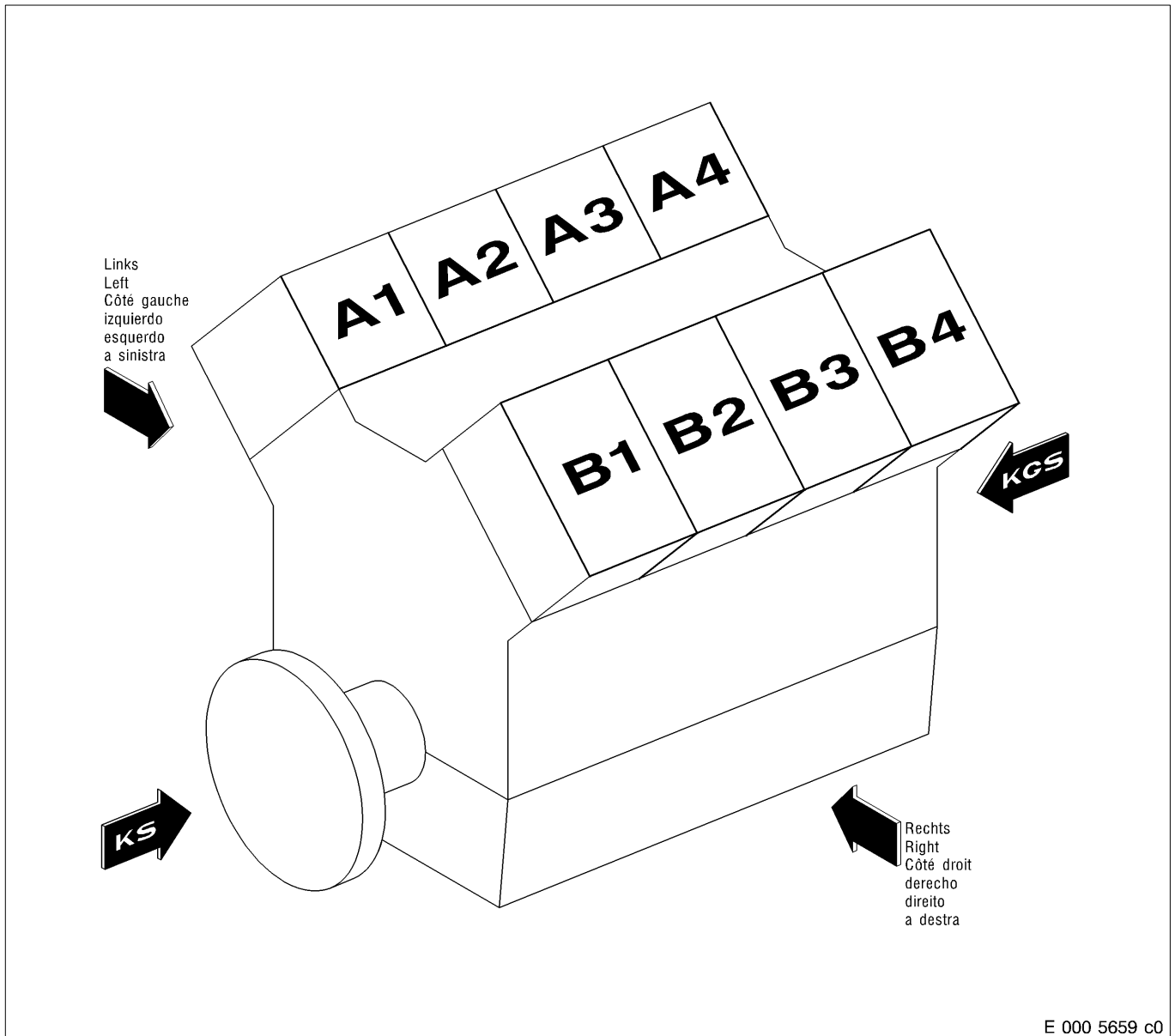

Designations and Abbreviations

Driving end = KS

Free end = KGS

Left side

Right side

Top end

Bottom end



A 003 Tightening specifications for screws, bolts and nuts

Designation	Tightening Specifications	Lubricant	See
Crankcase			
Centre hex screws for crankshaft bearing cap * Max. shaft length: 176 mm – Tightening torque: – Angle of further rotation:	300 Nm + 30 Nm 90° + 10°	Engine oil	C 011.05 C 031.05
Side double-hex screws for crankshaft bearing cap *	120 Nm + 10 Nm	Engine oil	C 011.05
Plugs for main oil ducts (M 30x 1.5)	180 Nm	Engine oil	C 011.05
Plug, driving end, for auxiliary PTO lubrication (M 18x 1.5)	80 Nm	Engine oil	C 011.05
Plug for centre coolant duct, driving end (M 60x 2)	350 Nm + 20 Nm	Engine oil	C 011.05
Plugs for coolant ducts to tappet chamber (M 26x 1.5)	150 Nm	Engine oil	C 011.05
Gear Train			
Double-hex screws for flywheel housing	100 Nm	Engine oil	C 021.05
Hex screws for belt pulley	180 Nm	Engine oil	C 028.05
Running Gear			
Screws for counterweights Max. shaft length: 84 mm – Tightening torque: – Angle of further rotation:	140 Nm + 20 Nm 90° + 10°	Engine oil	C 031.05
Double-hex screws for flywheel Max. shaft length: 75 mm	260 Nm	Engine oil	C 032.05
Hex screws for vibration damper	180 Nm	Engine oil	C 035.05
Conrod cap screws ** Max. shaft length: 74.5 mm – Tightening torque: – Angle of further rotation:	100 Nm + 15 Nm 90° + 10°	Engine oil	C 037.05

* Tightening sequence: Hex screws before double-hex screws

** Replace conrod cap screws with cracked mating faces during each engine disassembly

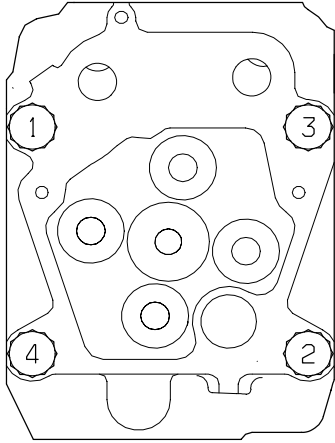
Designation	Tightening Specifications	Lubricant	See
Cylinder Head			
Double-hex screws for cylinder head Max. shaft length: 212 mm Pretightening torque, in stages: <ul style="list-style-type: none"> - 1st stage - 2nd stage - 3rd stage - 4th stage Angle of further rotation, in stages: <ul style="list-style-type: none"> - 1st stage - 2nd stage <u>Cylinder head tightening diagram</u>  K 041 0017 b0	10 Nm 50 Nm 100 Nm 200 Nm 90° + 10° 90° + 10°	Engine oil	C 041.05
Protective sleeve for injector	40 Nm + 5 Nm	Engine oil	C 041.05
Valve Gear			
Locknut on adjusting screw for rocker arm	50 Nm	Engine oil	C 055.05
Locknut on adjusting screw for valve bridge	25 Nm + 5 Nm	Engine oil	C 055.05
Hex screws for rocker shaft support Max. shaft length: 91 mm - Tightening torque: - Angle of further rotation:	60 Nm 90°	Engine oil	C 055.05
Collar screw for cylinder head cover	20 Nm	Engine oil	C 055.10
Fuel System – High-Pressure			
Screws for plug-in clips on injection pump	1 Nm ±0.2 Nm	Engine oil	C 073.05
Double-hex screws for injection pump	60 Nm + 12 Nm	Engine oil	C 073.05
Hex screw for clamping element on injector	50 Nm	Engine oil	C 075.05
Union nut of nozzle on nozzle holder	80 Nm + 10 Nm	Engine oil	Oper. Instr.
Union nut of injection line on injection pump	25 Nm + 2 Nm	Engine oil	C 075.05
Adapter of injection line in cylinder head	40 Nm	Engine oil	C 075.05

Designation	Tightening Specification	Lubricant	See
Fuel System (Low Pressure)			
Screw for driver of fuel pump on WP shaft	55 Nm	Engine oil	C 081.05
Fuel distribution housing: Hex screws for cover on housing	9 Nm + 1 Nm	Engine oil	C 084.05
Union (M 8 x 1)	11 Nm + 1 Nm	Engine oil	
Union (M 18 x 1.5)	54 Nm + 2 Nm	Engine oil	
Union (M 16 x 1.5)	39 Nm + 2 Nm	Engine oil	
Exhaust System			
Hex screws for exhaust manifold	60 Nm	Ultra Therm MTU	C 142.05
Starting System			
Hex nuts for starter on flywheel housing	80 Nm	Engine oil	C 172.05
Lube Oil System			
Hex screws for oil pump and oil pressure relief valve	35 Nm	Engine oil	C 181.05
Hex screws for oil suction line on oil pump	35 Nm	Engine oil	C 181.05
Hex screws for cover on oil pump housing	25 Nm	Engine oil	C 181.05
Non-return valve in crankcase	100 Nm	Engine oil	C 181.05
Nuts for oil cooling element and stud on cover of oil heat exchanger	108 Nm	Engine oil	C 183.05
Hex screws for cover on oil cooler housing	35 Nm	Engine oil	C 183.05
Screws for oil spray nozzle	25 Nm	Engine oil	C 184.10
Cooling System			
Nut for impeller (coolant pump) – Tightening torque:	300 Nm + 25 Nm	Special lubricating paste DDC 7Y2	C 202.05
Interference fit of impeller – Checking torque:	340 Nm		
Power Supply, Engine Side			
Hex screw for generator on bracket	82 Nm + 12 Nm	Engine oil	C 213.05
Screw for stress bolt on bracket	82 Nm + 12 Nm	Engine oil	C 213.05
Screw for link on generator	82 Nm + 12 Nm	Engine oil	C 213.05
Nut for belt pulley on generator	95 Nm + 13 Nm	Engine oil	C 213.05
Cooling Air System			
Hex screws for bracket of bearing unit on retainer	100 Nm	Engine oil	C 221.05
Nut for bearing on bracket	339 Nm + 13 Nm	Engine oil	C 221.05
Hex screw for ball bearing in belt tensioner	58 Nm + 15 Nm	Engine oil	C 221.05
Mounting			
Double-hex screws for cover on carrier, free end	260 Nm + 10 Nm	Engine oil	C 231.05
Monitoring, Control and Regulation Devices			
Charge air pressure transmitter on charge air manifold	25 Nm	Engine oil	–

Tightening specification for set screw and stud connections to works standard MTN 5008

This works standard applies to set screws subjected to little dynamic load as per MMN 384, DIN 912, EN 24014 (DIN 931-1), EN 24017 (DIN 933), EN 28765 (DIN 960), EN 28676 (DIN 961), DIN 6912 and to studs as per DIN 833, DIN 835, DIN 836, DIN 938, DIN 939 and associated nuts.

It does not apply to heat-proof screws in the hot component area.

Tightening torques M_A are for screws of strength class 8.8 (bright surface, phosphate coating or galvanised) and 10.9 (bright surface or with phosphate coating).

The values in the table are based on a friction coefficient $\mu_{tot} = 0.125$. Precondition: Thread and mating faces of screws and nuts must be coated in engine oil prior to assembly.

When tightening manually (tightening specifications), an assembly tolerance of + 10% of the table values is permitted for unavoidable deviations of the tightening torque from the table value during the tightening process – e.g. resulting from inaccurate readings and overtightening during assembly.

When tightening mechanically, the permitted assembly tolerance is + 15%

Tightening torques = M_A

Thread	Hand-tightened		Machine-tightened	
	8.8 M_A (Nm)	10.9 M_A (Nm)	8.8 M_A (Nm)	10.9 M_A (Nm)
M 6	9	12	8	11
M 8	21	31	20	28
M 8 x 1	23	32	21	30
M 10	42	60	40	57
M 10 x 1.25	45	63	42	60
M 12	74	100	70	92
M 12 x 1.25	80	110	75	105
M 12 x 1.5	76	105	72	100
M 14	115	160	110	150
M 14 x 1.5	125	180	120	170
M 16	180	250	170	235
M 16 x 1.5	190	270	180	255
M 18	250	350	240	330
M 18 x 1.5	280	400	270	380
M 20	350	500	330	475
M 20 x 1.5	390	550	350	520
M 22	480	680	450	650
M 22 x 1.5	520	730	490	700
M 24	600	850	570	810
M 24 x 1.5	680	950	640	900
M 24 x 2	660	900	620	850
M 27	900	1250	850	1175
M 27 x 2	960	1350	900	1275
M 30	1200	1700	1100	1600
M 30 x 2	1350	1900	1250	1800

A004 Settings

Firing order

A1 – B4 – A4 – A2 – B3 – A3 –B2 – B1

Direction of rotation as viewed from driving end

Crankshaft	counterclockwise
Camshaft	clockwise
Fuel delivery pump	counterclockwise
Oil pump	clockwise
Engine coolant pump	counterclockwise

Valve clearance, engine cold (20 °C)

Inlet	0.40 mm
Outlet	0.60 mm

Valve timing, valve clearance adjusted

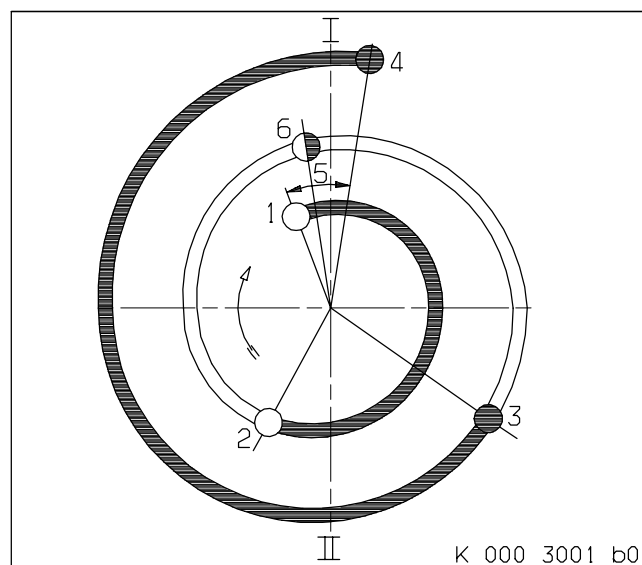

	° Crank angle
1 Inlet valve opens	12.4° before TDC
2 Inlet valve closes	18.4° after BDC
3 Exhaust valve opens	55.6° before BDC
4 Exhaust valve closes	9.2 ° after TDC
5 Overlap	21.6°
6 Start of delivery	Map based

I Top dead centre (TDC)
II Bottom dead centre (BDC)

Fuel injection pressure

Setting pressure with new spring	300 to 310 bar
Minimum pressure with run-in spring	260 bar

Cam and valve lift for camshaft adjustment

	Inlet	Outlet
Cam lift at TDC	0.70mm	0.60 mm
Valve lift at TDC (zero valve clearance)	0.85 mm	0.80 mm

A 005 Hazards in the Work Area

These Safety Instructions must be read and followed by any persons operating, carrying out maintenance or repairs on the machinery plant.

General Safety and Accident Prevention Regulations

- In addition to the instructions given in this publication, general safety and accident prevention regulations and laws must be taken into consideration; these may vary from country to country.
- This MTU engine is a state-of-the-art product and conforms with all the applicable specifications and regulations. Nevertheless, persons and property may be at risk in the event of:
 - Incorrect use
 - Servicing, maintenance and repair carried out by untrained members of staff
 - Modifications or conversions
 - Noncompliance with the Safety Instructions

Correct Use

- The engine is to be used solely for the purpose stated in the contract. Any other use is considered improper use. The manufacturer will accept no liability for any resultant damage. The responsibility is borne by the user alone.
- Correct use also includes observation of the Operating Instructions and Maintenance Manual and compliance with maintenance and repair instructions.

Personnel Requirements

- Work on the engine must be carried out only by reliable personnel. The specified legal minimum age must be respected.
- Only fully-trained or qualified personnel must be employed. Responsibilities of the operating, maintenance and repair personnel must be specified.

Modifications or Conversions

- Modifications made by the customer to the engine may affect safety. No modifications or conversions must be implemented out without prior consent from DDC or MTU.
- No liability will be accepted for damage resulting from unauthorised modifications.

Organisational Measures

- This Operation Manual must be made available to maintenance and servicing personnel.
- The personnel must be instructed on engine operation and repair by means of the Operation Manual, and in particular the safety instructions must be explained. This is especially important for personnel who work on the engine only on an occasional basis.
- This copy is then only subject to the Amendment Service if the acknowledgement of receipt card has been returned to MTU.

Spare Parts

- Spare parts must at least satisfy the requirements specified by the manufacturer. This is guaranteed when original components are used.

Working Clothes and Protective Equipment

- Always wear protective shoes when working on plant.
- Select appropriate protective goggles for the work to be carried out. Always wear protective goggles when working with mallets, cutting tools, drift punches and associated tools.
- Work clothing must be tight-fitting so that it does not catch on rotating or projecting components. Do not wear jewellery (e.g. rings, chains, etc.).

Welding Operations

- Never use the engine as a ground terminal! – (This prevents the welding current from passing through the engine, resulting in burnt or scorched points on the bearings, friction surfaces and tooth flanks which can lead to bearing scorching and/or material damage)
- Welding operations on the engine or mounted plants are not permitted.
- Never lay the welding cable over or near the cable harnesses of the DDC/MTU plants. (The welding current could be induced in the cable harnesses which could possibly damage the electrical plant)
- The ground terminal of the welding unit must be connected to the welding point at a distance no greater than 60 cm.
- If welding must be carried out on components (e.g. exhaust pipe), these components must be removed from the engine beforehand.
- At the DDC/MTU electronics system, it is not necessary to remove the connector and connections to carry out welding operations if the master switch of the power supply is switched from "On" to "Off" and the cable has been disconnected from the negative and positive poles on the battery.
- During welding operations, always wear welding gloves, headgear/goggles, protective aprons and other suitable protective clothing.

Transport

- Lift the engine only with the lifting eyes provided.
- Use only the transport and lifting equipment approved by DDC/MTU.
- The engine must only be transported in installation position.

Engine Operation

- When the engine is running, ear protectors must always be worn in the engine room.
- The engine room must be well ventilated.
- To avoid injuries caused by falling, leaked or spilt engine oil and coolant must be cleaned up immediately or absorbed with appropriate bonding agents.
- Exhaust gases from combustion engines are poisonous and injurious to health if inhaled. The exhaust pipework must be leak-free and discharge exhaust gases to atmosphere.
- During engine operation, do not touch battery terminals, generator terminals or cables. Inadequate protection of electrical components can lead to electric shocks and serious injuries.
- If engine is running, never release coolant, oil, fuel, compressed air or hydraulic lines.

Maintenance and Repair

- Compliance with maintenance specifications is an important safety factor.
- Unless expressly permitted, no maintenance or repair work must be carried out with the engine running. The engine must be secured against inadvertent starting and the battery disconnected. Attach sign "Do not operate" in operating area or to control equipment. Persons not involved must keep clear.
- Never attempt to rectify faults or carry out repairs if you do not have the necessary experience or special tools required. Maintenance work must only be carried out by authorised, qualified personnel.
- Use only tools in perfect condition.
- Do not work on engines or components which are only held by lifting equipment or crane. Always support these components on suitable frames or stands before beginning any maintenance or repair work.
- Before barring the engine, ensure that nobody is within the danger area. After working on the engine, check that all guards have been reinstalled and that all tools and loose components have been removed from the engine.

- Fluids emerging under high-pressure can penetrate clothing and skin and may cause serious injury. Before starting work, relieve pressure in systems and H.P. lines which are to be opened.
- Never bend a fuel line and do not install bent lines. Keep fuel injection lines and connections clean. Always seal connections with caps or covers if a line is removed or opened.
- During maintenance or repair work, do not hit fuel lines with wrenches or other tools. To tighten connections when installing lines, use the correct tightening torque and ensure that all retainers and dampers are installed correctly.
- Ensure that all fuel injection lines and compressed oil lines have sufficient play to avoid contact with other components. Do not place fuel or oil lines near hot components.
- The H.P. lines for hydraulic installation and removal are tested with 3800 bar.
- Do not attempt to bend or apply force to lines.
- In order to avoid burning, take special care when handling hot components on products just taken out of use and when working with hot liquids in pipelines, pipes and chambers.
- Until the engine has cooled, the breather cap must not be opened. Release the breather cap and allow pressure to escape before cap removal.
- Take special care when removing ventilation or plugs from engine. In order to avoid being sprayed with highly-pressurised liquids, hold a cloth over the screw or plug. It is even more dangerous if the engine has recently been shut down as the liquids can still be hot
- Take special care when draining hot fluids – risk of injury. Drain the fluids into a suitable container and wipe up any spillages.
- When changing engine oil or working on the fuel system, ensure that the engine room is adequately ventilated.
- When working high on the engine, always use suitable ladders and work platforms. Make sure components are placed on stable surfaces.
- To avoid damaging your back when lifting components weighing 25 kg (50 lb.) or more, use lifting gear or request aid from other workers. Ensure that all chains, hooks, slings, etc. are in good condition, are sufficiently strong and that hooks are correctly positioned. Lifting eyes must not be unevenly loaded.
- When operating electrical equipment, certain components of this equipment are live.
- Noncompliance with warning notices could result in serious physical injury or damage to property.
- Work must be carried out only by qualified personnel. Prior to working on electrical equipment, switch off live units.
- Gases released from the battery are explosive. Avoid sparks and naked flames. Do not allow battery acids to come into contact with skin or clothing. Wear protective goggles. Do not place tools on the battery. Before connecting the cable to the battery, check battery polarity. Battery pole reversal may lead to injury through the sudden discharge of acid or bursting of the battery body.
- Do not damage wiring during removal work and when reinstalling wiring and ensure that during operation it is not damaged by contact with sharp objects, by rubbing against another component or by a hot surface. Never connect wiring to a line which carries liquid.
- On completion of the maintenance and repair work, any cables which have become loose must be correctly secured.
- Always tighten connectors with connector pliers.
- If cables are present at mechanical components and there is a risk of wear, the cables must be retained in cable clamps.
- For this purpose, no cable straps must be used as, during maintenance and/or repair work, the straps can be removed but not installed a second time.
- Check security of all plug-in connections.

- It is not sufficient to tighten the connections by hand with a bayonet union. There is the risk that the locking unit does not engage correctly and that the connector becomes loose during engine operation. For this reason, connector pliers must be used to turn the bayonet union in a clockwise direction!

Fire Prevention

- Rectify any fuel or oil leaks immediately; even splashes of oil or fuel on hot components can cause fires – therefore always keep the engine in a clean condition. Do not leave oil-soaked cloths on the engine. Do not store combustible fluids near the engine. Do not allow dirt or foreign matter to accumulate near the engine, as this constitutes a fire hazard.
- Welding work must not be carried out on pipes and components containing oil. Before welding, clean with a noncombustible fluid.
- Never mix petrol/gasoline with diesel fuel. If petrol/gasoline is added to diesel fuel, there is increased risk of fire.
- When starting the engine with a foreign power source, connect the ground lead last and remove it first. To avoid sparks in the vicinity of the battery, connect the ground lead from the foreign power source to the ground lead of the engine or to the ground terminal of the starter.
- Always keep a fire extinguisher at hand and learn how to operate it.

Noise

- Hearing may be impaired at workplaces where the sound pressure level is in excess of 85 dB(A).
- Wear earplugs or earmuffs!

Environmental Protection

- Dispose of used fluids and lubricants and filters in accordance with local regulations.
- Manipulation of the injection or control system can influence the engine performance and exhaust emissions. As a result, compliance with environmental regulations may no longer be guaranteed.

Skin Complaints

- Barrier creams issued for prophylactic use are not suitable for treatment of skin complaints. Seek medical advice on skin rashes of any type, even if symptoms are very slight.

Warning Signs

- Before putting the engine into service and before working on the engine, read and follow all warning signs. Do not paint on warning signs. Replace illegible signs.

Auxiliary Materials

- Use only fluids and lubricants that have been tested and approved by DDC and/or MTU.
- Fluids and lubricants must be kept in properly designated containers. When using fluids, lubricants and other chemical substances, follow the safety instructions applicable to the product. Take special care when using hot and caustic materials. When using inflammable materials, avoid all sparks and do not smoke.

Lead

- When working with lead or pastes that contain lead, take care that the body does not absorb even tiny amounts of lead (from air-borne lead dust, smoke, dirty hands).
- Adopt suitable measures to avoid the formation of lead dust!
- Switch on extraction system!
- Wash hands before consuming food or beverages!

Chlorinated Hydrocarbons

- When working with chlorinated hydrocarbons (e.g. perchlorethylene, trichlorethane) or other cold cleaners which contain declared hazardous substances, health-endangering substances may be inhaled.
- Switch on ventilation and extraction systems!
- Observe fire-prevention regulations!
- No smoking and no consumption of alcoholic beverages!
- Do not permit substances to enter the waste-water system!

Acids and Alkalis

- When working with acids and alkalis, wear protective goggles or face mask, gloves and protective clothing.
- Immediately remove clothing wetted by acids and alkalis!
- Rinse injuries with plenty of clean water!
- Rinse eyes immediately with water from rinsing bottle or clean mains water!

Painting

- When painting in other than spray booths equipped with extractors, ensure good ventilation. Ensure that neighbouring workplaces suffer no detrimental effects.
- Always wear a mask providing protection against paint and solvent vapours!
- Observe all fire-prevention regulations!
- No smoking!
- No naked flame!

Liquid Oxygen

- Liquid oxygen is highly flammable.
- Store liquid oxygen only in small quantities and always in regulation containers (without fixed seal)! Do not bring into contact with parts of the body (hands); causes cold burns and severe frostbite.
- No smoking, no naked flame (risk of explosion)! Oxygen enrichment in the air causes flash combustion.
- Do not store combustible substances (e.g. oils and greases) within 5 m of the working area!
- Under no circumstances wear oily or greasy clothing!
- Do not allow vapours to penetrate clothing! Oxygen enrichment in fabric can cause working clothes to ignite suddenly!
- After working with liquid oxygen, do not smoke until clothing is free of vapours!
- Take great care to avoid impact and shock when working with liquid oxygen!

Liquid Nitrogen

- Store liquid nitrogen only in small quantities and always in regulation containers (without fixed seal)!
- Do not allow liquid nitrogen to come into contact with parts of body (eyes, hands). Liquid nitrogen causes cold burns and severe frostbite.
- Wear protective clothing (including gloves and closed shoes) and protective goggles!
- Ensure good ventilation (suffocation if nitrogen enrichment in inhaled air reaches 88%)
- Do not subject containers, fittings and tools to impact or shock!

Compressed Air

- Compressed air is compressed, pressurised air and is stored in pressure vessels from which the compressed air is then extracted.
- The compressed air pressure can be read off at the pressure indicator (pressure gauge); the pressure vessels and compressed air lines must also be at this pressure.
- High-pressure is harmful to the human body, especially if applied suddenly.

- When working with compressed air, safety precautions must be constantly observed:
 - Pay special attention to the pressure level in the compressed air network and pressure vessel!
 - Connecting devices and equipment must either be designed for this pressure or, if the permitted pressure for the connecting elements is lower than the pressure required, a pressure reducing valve and safety valve (set to permitted pressure) must form an intermediate connection. Hose coupling and connections must be securely attached!
 - Always wear protective goggles when blowing off tools or extracting chips!
 - The snout of the air nozzle is provided with a protective disc (e.g. rubber disc), which prevents air-borne particles being reflected and thereby prevents damage to the eyes.
 - First shut off compressed air lines before compressed air equipment is disconnected from the supply line or before equipment or tool is to be replaced!
 - Unauthorised use of compressed air, e.g. forcing flammable liquids (danger class A1, A11 and B) out of containers, results in a "Risk of explosion"!
 - Forcing compressed air into thin-walled containers (e.g. containers made of tin, plastic and glass) for drying purposes or to check for leaks results in a "Risk of explosion"!
 - Removing dirt on soiled clothes while still worn can result in a "Risk of injury".
Even compressed air at low pressure penetrates clothing and, if the jet is directed at the back, the air can enter the anal cavity and fatally rupture the intestines!

Used Oil

- Used oil may contain health-threatening combustion residues.
 - Rub barrier cream into hands!
 - Clean hands thoroughly after contact with used oil!

Warning Notices

- Section "C" of this Publication contains especially emphasised safety instructions in accordance with the American standard ANSI Z535, which begin with one of the following signal words according to the degree of danger:
 - Take extreme care in these situations!
 - Read and become acquainted with all warning notices and symbols before operating or repairing this product!
 - Inform operating and maintenance personnel on all Safety Instructions!

 DANGER
An instruction of this type draws attention to an impending danger which, if ignored, may lead to injury or death.

 WARNING
An instruction of this type draws attention to a possible danger which, if ignored, may lead to injury or death.

 CAUTION
An instruction of this type draws attention to a danger which, if ignored, may lead to injury or death.

A006 Data Sheets

To ensure that unusable components are not installed or components which can still be used are not discarded all inspection work should only be carried out by qualified personnel using the necessary measuring instruments.

All measuring and testing equipment is naturally subject to wear.

To determine resulting tolerance deviations in good time, the measuring and test equipment must be inspected annually at a location equipped with appropriate technical facilities.

Alternatively, an inspection can also be carried out by our product support service and DDC/MTU or by an external product support service.

On no account can the measurements be below or above the limit values as specified in the Tolerances and Wear Limits List.

The following data sheets should be used to record the individual examination results:

- Crankcase bores (2x)
- Single-component crankshaft bearing (driving end/free end)
- Cylinder liner (installed)
- Crankshaft data sheet
- Crankshaft bearing
- Conrod bearing (shells installed)
- Control times and injection timing



MTU Friedrichshafen Department: QSP-F	Test Sheet for Crankcase	for sheet No. 1 appendix A Crankcase no. _____ Casting date: _____
Material:	_____ V _____ Part no. _____	OHAU / Order

Cylinder No.		1	2	3	4	5
<u>A (L) – side</u>	
Fit diameter	A
Top	B
Fit diameter	A
Bottom	B
Recess depth	
Balcony	

Cylinder No.		6	7	8	9	10
<u>A (L) – side</u>	
Fit diameter	A
Top	B
Fit diameter	A
Bottom	B
Recess depth	
Balcony	

Cylinder No.		1	2	3	4	5
<u>B (R) side</u>	
Fit diameter	A
Top	B
Fit diameter	A
Bottom	B
Recess depth	
Balcony	

Cylinder No.		6	7	8	9	10
<u>B (R) side</u>	
Fit diameter	A
Top	B
Fit diameter	A
Bottom	B
Recess depth	
Balcony	

Remarks:	

MTU Friedrichshafen Dept.: QSP-F		Test sheet for crankcase				for sheet No. 1 appendix B Housing No. _____ Casting date: _____				
Material:		_____ V _____ Part No. _____				OHAU / Order				
Main bearing bore diameter						Camshaft bearing diameter				
Bear- ing No.	front direction			rear direction			le. side direction		ri. side direction	
	a	c1	c2	a	c1	c2	a	b	a	b
1										
2										
3										
4										
5										
6										
8										
9										
10										
11										
12										
Remarks:										

ASSEMBLY DATA SHEET

One-Part Crankshaft Bearing



Engine type
Engine No.
Crankcase No.
Operating hours
Item
Specified dia.

Note:
 Measuring point a for bearing clearance

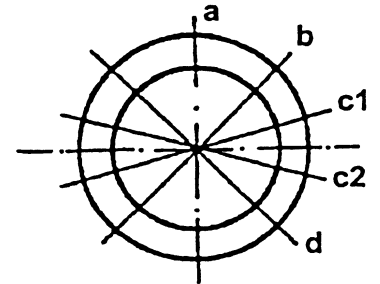

Measuring points

Component	Crankshaft bearing	a	b	c1	c2	d	Mean dimension
	Driving end						
	Free end						

Note:

Specified values from the Tolerances and Wear Limits List

Date:

Tester:

**Assembly Data Sheet
Cylinder Liners (installed)**

Engine Model

Engine No.

Crankcase No.: _____

Cyl. bush part No.: _____

Specified dimension, bore: _____

To measure: In measuring direction a (direction of travel) and b (transverse)
Measuring levels 1 – 2 – 3 – 4

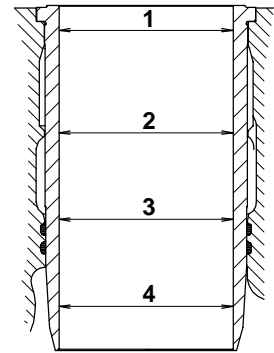

Cylinder No.	Measuring direction	Basic dimension	Actual dimensions				Cylinder No.	Measuring direction	Basic dimension	Actual dimensions			
			Measuring levels							Measuring levels			
			1	2	3	4				1	2	3	4
1A	a						B1	a					
	b							b					
2A	a						B2	a					
	b							b					
3A	a						B3	a					
	b							b					
4A	a						B4	a					
	b							b					
5A	a						B5	a					
	b							b					
6A	a						B6	a					
	b							b					
7A	a						B7	a					
	b							b					
8A	a						B8	a					
	b							b					
9A	a						B9	a					
	b							b					
10A	a						B10	a					
	b							b					

Remarks:

Specified dimensions from Tolerances and Wear Limits List

Date:

Inspected by:

**KURBELWELLEN-KENNBLATT
CRANKSHAFT DATA SHEET**

Model _____
Model _____

Sach-Nr. _____
Item No. _____

Zeichnungs-Nr. _____
Drawing No. _____

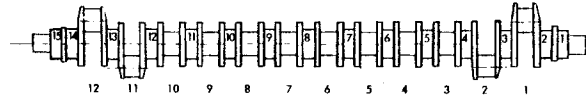

Wellen-Nr. _____
Shaft No. _____

Abnahme
Classification _____

Meßstelle / Measuring Point	15	14	13	12	11	10	9	8	7	6	5	4	3	2	1
Hublager-Ø Crankpin Dia. _____															
Grundlager-Ø Main Journal Dia. _____															

Anlaufbund _____
Thrust collar _____
Rundlauf _____
Concentricity _____
Härte Hublager _____
Crankpin hardness _____
Härte Grundlager _____
Journal hardness _____
Crack test _____
Crack test _____

Ölbohrungen einwandfrei gereinigt und verrundet.
Oil ducts thoroughly cleaned and edges smoothed.
Sämtliche Hohlkehlen und Ansenkungen nach Zeichnung.
All fillets and countersinks as per drawing.
Gegengewichtsauflageflächen Rt und Ebenheit nach Zeichnung.
Roughness height and flatness of counterweight seating surface as per drawing.
Winkligkeit der Gegengewichtbefestigungsgewinde nach Zeichnung.
Angularity of counterweight securing thread as per drawing.
Prüfmoment der Gegengewichtbefestigung nach Zeichnung.
Test torque of counterweight boltet joint as per drawing.

Bemerkungen / Remarks:

, den

Prüfer / Checked by:

Freigabe / Approved by:

Assembly Data Sheet

Engine Model

Crankshaft Main Bearing

Engine No.

Crankcase No.: _____

Crankshaft No.: _____

Specified dimensions:

Main bearings dia.: _____

Crankshaft dia.: _____

Radial clearance: _____

Crankshaft axial clearance: _____

Actual dimension: _____

Measuring and entry: Smallest dimension, diameter a, b1 and b2, measuring level 1 and 2

Determining bearing clearance: Smallest dimension a

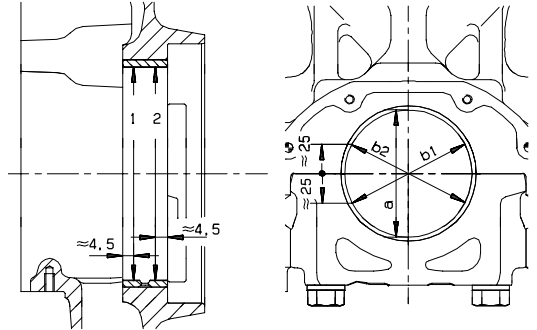

Bearing No.	Actual dimensions						
	Basic dimension	1	2	3	4	5	6
Bearing dia. b1							
Bearing dia. b2							
Bearing dia. a							
Crankshaft- (actual dimension)							
Bearing clearance, rad.							

Bearing No.	Actual dimensions						
	Basic dimension	7	8	9	10	11	12
Bearing dia. b1							
Bearing dia. b2							
Bearing dia. a							
Crankshaft dia. (actual dimension)							
Bearing clearance, rad.							

Remarks

Specified dimensions from Tolerances and Wear Limits List

Date: _____

Inspected by: _____

**Assembly Data Sheet
Conrod Bearing Spot Check
(Shells installed)**

Engine Model

Engine No.

Crankcase No.: _____ Specified dimensions: _____
 Crankshaft No.: _____ Conrod bearing bore _____
 Radial play _____

To measure: Diameter a, b1, b2
 For calculating play, smallest dimension a, b1 or b2

Connecting rod A row

Cyl. No.	Rod No.	Actual dimension					
		Basic dimension	a dimension	b1 dimension	b2 dimension	Crankshaft	Radial play
1							
2							
3							
4							
5							
6							
7							
8							
9							
10							

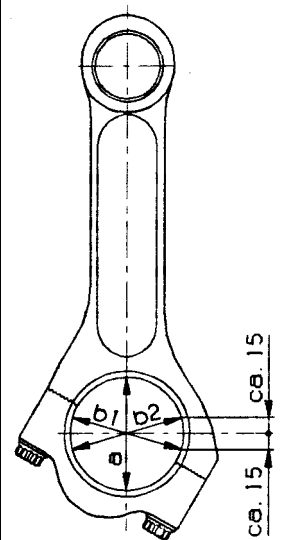

Connecting rod B row

Cyl. No.	Rod No.	Actual dimensions					
		Basic dimension	a dimension	b1 dimension	b2 dimension	Crankshaft	Radial play
1							
2							
3							
4							
5							
6							
7							
8							
9							
10							

Remarks:

Date:

Inspected by:



Assembly Data Sheet

Control Times and Injection Timing

Engine Model

Engine No.

1. Control diagram

	Specified	Actual					
		Cylinder No.					
Exhaust valve opens before BDC							
Inlet valve opens before TDC							
Exhaust valve closes after TDC							
Inlet valve closes after BDC							

Settings for control times correspond to "setting diagrams"

2. Cam lift

	Specified	Actual					
		Cylinder No.					
Inlet							
Exhaust							

3. Injection timing

For start of delivery, see engine master card

Remarks:

Date:

Inspected by:

A007 Conversion Tables

Length SI unit: m
Other permitted units: μm , mm, km

Unit A	multiplied by factor	=	Unit B
in	25.40	=	mm
ft	0.3048	=	m
yd	0.9144	=	m
stat. mile	1.609	=	km
yd	3	=	ft
yd	36	=	in

Unit B	multiplied by factor	=	Unit A
mm	0.03937	=	in
m	3.281	=	ft
km	0.6215	=	stat. mile

Area SI unit: m^2
Other permitted units: mm^2 ; a (Ar) = 100 m^2 , ha

Unit A	multiplied by factor	=	Unit B
in^2 (sq in)	645.16	=	mm^2
ft^2 (sq ft)	0.0929	=	m^2
yd^2 (sq yd)	0.8361	=	m^2
stat. mile ²	2.5889	=	km^2

Unit B	multiplied by factor	=	Unit A
mm^2	0.00155	=	in^2 (sq in)
m^2	10.7643	=	ft^2 (sq in)
m^2	1.1960	=	yd^2 (sq yd)
km^2	0.3863	=	stat. mile ²

Volume SI unit: m^3
Other permitted units: l, mm^3 , cm^3 , dm^3

Unit A	multiplied by factor	=	Unit B
in^3 (cu in)	16387	=	mm^3
ft^3 (cu ft)	0.02832	=	m^3
yd^3 (cu yd)	0.7646	=	m^3
gallon (US)	3.787	=	dm^3
gallon (brit.)	4.546	=	dm^3

Unit B	multiplied by factor	=	Unit A
cm^3	0.06102	=	in^3 (cu in)
m^3	35.31	=	ft^3 (cu ft)
dm^3	0.2642	=	gallon (US)
dm^3	0.22	=	gallon (brit.)

Speed

SI unit: m/s
 Other permitted units: km/h

Unit A	multiplied by factor	=	Unit B
ft/s	0.3048	=	m/s
stat. mile/h (mph)	1.609	=	km/h
knot (brit.)	1.852	=	km/h

Unit B	multiplied by factor	=	Unit A
m/s	3.281	=	ft/s
km/h	0.6215	=	stat. mile/h (mph)
km/h	0.54	=	knot (brit.)

Mass

SI unit: kg
 Other permitted units: mg, g, t

Unit A	multiplied by factor	=	Unit B
lb	0.4536	=	kg
oz	28.35	=	g
ton	1.016	=	t

Unit B	multiplied by factor	=	Unit A
g	0.03527	=	oz
kg	2.205	=	lb
t	0.9843	=	ton

Force

SI unit: N
 Other permitted units: mN, kN, MN

Unit A	multiplied by factor	=	Unit B
lb	0.4536	=	kp
lb	4.4483	=	N

Unit B	multiplied by factor	=	Unit A
kp	2.205	=	lb
N	0.101972	=	kp
kp	9.80665	=	N

Pressure SI unit: Pa
Other permitted units: bar, mbar, μ bar; 1 bar = 10^5 Pa

Unit A	multiplied by factor	=	Unit B
lb/sq in (psi)	703.1	=	kp/m ² (mm WS)
lb/sq in (psi)	0.06895	=	bar
lb/sq ft	47.883	=	Pa
in QS	0.03386	=	bar
in QS	345.3	=	kp/m ²

Unit B	multiplied by factor	=	Unit A
atm	760	=	mm QS
atm	1.0133	=	bar
atm	10332	=	kp/m ² (mm WS)
atm	1.0332	=	kp/cm ² (at)
atm	14.696	=	lb/sq in
bar	14.503	=	lb/sq in

Density SI unit: kg/m³
Other permitted units: g/cm³, kg/dm³, kg/l

Unit A	multiplied by factor	=	Unit B
lb s ² /ft ⁴	515.4	=	kg/m ³

Unit B	multiplied by factor	=	Unit A
kg/m ³	0.00194	=	lb s ² /ft ⁴

Torque SI unit: Nm

Unit A	multiplied by factor	=	Unit B
ft lb	1.3563	=	Nm

Unit B	multiplied by factor	=	Unit A
Nm	0.7373	=	ft lb

Mass moment, 2nd grade SI unit: kg m²

Unit A	multiplied by factor	=	Unit B
ft lb s ²	1.3563	=	kg m ²

Unit B	multiplied by factor	=	Unit A
kg m ²	0.7373	=	ft lb s ²

Energy SI unit: J
 Other permitted units: kJ, kWh

Unit A	multiplied by factor	=	Unit B
ft lb	1.356	=	J
kcal	4186.8	=	J
BTU	1055	=	J
CHU	1899	=	J

Unit B	multiplied by factor	=	Unit A
J	0.7376	=	ft lb
J	0.0002389	=	kcal
J	0.0009479	=	BTU
J	0.00052656	=	CHU

Power SI unit: W; 1 W = 1 J/s = 1 Nm/s
 Other permitted units: kW, kJ/h

Unit A	multiplied by factor	=	Unit B
PS	0.7355	=	kW
HP	0.7457	=	kW
BTU/s	1.055	=	kW
kcal/h	1.163	=	W
HP	550	=	ft lb/s

Unit B	multiplied by factor	=	Unit A
kW	1.36	=	PS
kW	1.341	=	HP
kW	0.9479	=	BTU/s
W	0.8598	=	kcal/h
ft lb/s	0.0018	=	HP

Temperature SI unit: K
 Other permitted units: °C; 1 °C = 273.15 K, °F = 9/5 °C + 32

	Celsius	Kelvin	Fahrenheit	Réaumur
x °C	–	= x + 273.15 K	= 9/5 x + 32 °F	= (4/5 x) × °R
x K	= x – 273.15 °C	–	= 9/5 (x – 273.15) + 32 °F	= 4/5 (x – 273.15) × °R
x °F	= 5/9 (x – 32) °C	= 5/9 (x – 32) + 273.15 K	–	= 4/9 (x – 32) × °R
x °R	= 5/4 x °C	= (5/4 x) + 273.15 K	= (9/4 x) + 32 °F	–

Specific fuel consumption

Unit A	multiplied by factor	=	Unit B
mile/gal (US)	0.4251	=	km/l
gal/mile (US)	2.3527	=	l/km

Unit B	multiplied by factor	=	Unit A
km/l	2.3527	=	mile/gal (US)
l/km	0.4251	=	gal/mile (US)

A008 Publication Summary

Other applicable Customer Service documents:

- Operating Instructions M 015315
- Fluids and Lubricants Specification 060600 A
- Tools List M004028/10
- Tolerances and Wear Limits List M 070034
- Description of function and operation of ECS
- Exhaust turbocharger K 31

Specialised information on subjects such as

- Fuel injection
- Governor setting

can be found in the Acceptance Test Record or Governor Record for the engine in question.

A009 Repairing threaded bores with threaded inserts (Heli-Coil)

Data

Thread	Core hole bore-dia. (max./min.)	Twist drill-dia.
M 6	<u>6.31</u> 6.04	6.1–6.2–6.25
M 8	<u>8.35</u> 8.04	8.1–8.2–8.25–8.3
M 8 x 1	<u>8.32</u> 8.04	8.1–8.2–8.25–8.3
M10	<u>10.40</u> 10.05	10.25
M12	<u>12.50</u> 12.05	12.25–12.5
M 12 x 1.5	<u>12.43</u> 12.05	12.25
M14	<u>14.53</u> 14.06	14.25–14.5
M 14 x 1.5	<u>14.43</u> 14.05	14.25
M 15 x 2	<u>15.30</u> 15.20	15.25
M16	<u>16.53</u> 16.06	16.25–16.5
M 16 x 1.5	<u>16.43</u> 16.05	16.25
M 24 x 1.5	<u>24.43</u> 24.05	24.25
M 26 x 1.5	<u>26.43</u> 26.05	26.25
M 30 x 1.5	<u>30.43</u> 30.05	30.25

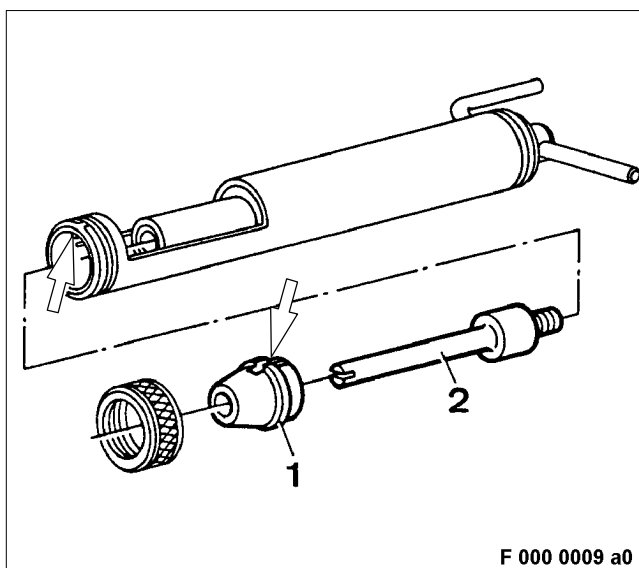

Repairing

If necessary, remove thread insert with suitable removal tool from bore (left).

Bore core hole with suitable twist drill – see table.

Cut thread with special tapped bore.

Note: Do not countersink bore!

Mount spindle (2) and snout (1) corresponding with thread.

Groove on snout must be aligned with markings on installation tool (arrows).

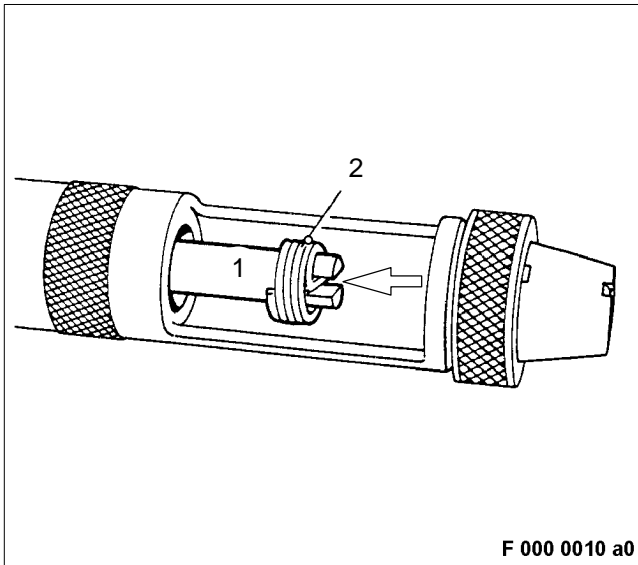

Insert thread insert (2) into spindle (1) in installation tool.

Driver journal of thread insert must be in groove (arrow).

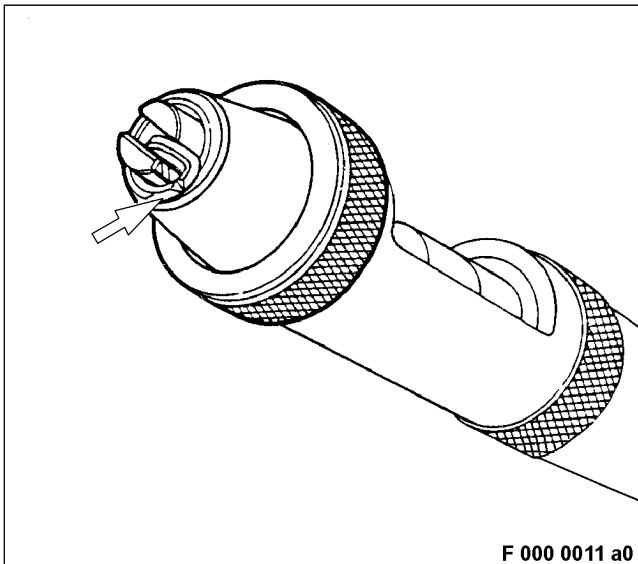

Use spindle to turn thread insert through snout until it is flush at front (arrow).

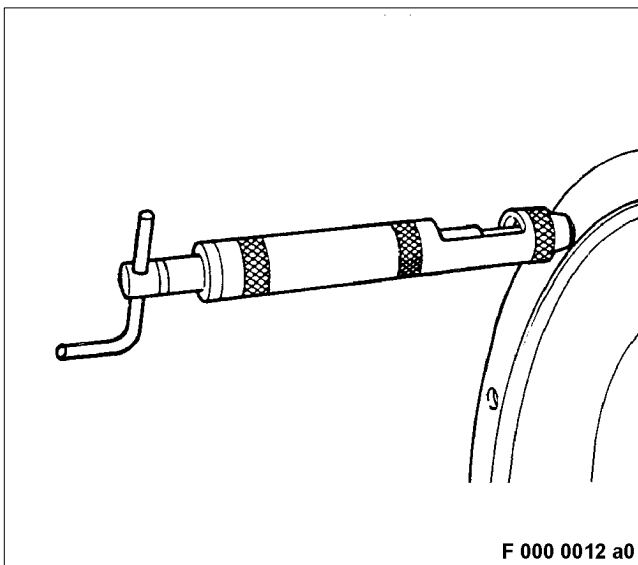

Mount installation tool on threaded hole and install thread insert without applying pressure to spindle.

Note: Insert thread insert 1/2 to 1 1/2 turns deeper than threaded bore surface.

Use bolt shearer to remove driver journal to M 14.
In event of threaded inserts over M 14, move driver journal up and down with pointed pliers and remove.

C 011.05.04 Before-Removal Operations

A distinction must be made as to whether:

- 1 ————— The engine is to be completely disassembled
- 2 ————— The engine is to be removed but not disassembled
- 3 ————— The engine is to remain installed

1	2	3	Operations	See
x	-	-	Remove engine	B 003
x	-	-	Perform operations as per Disassembly Plan	B 004
-	x	x	Removal not scheduled	-

C 011.05.08 Inspection and Repair

Clean all parts.

Using the surface crack-testing method with red penetrant dye, check crankcase for cracks.

Check mating faces and upper and lower fits for cylinder liners in crankcase for wear, damage and cavitation.

In event of wear and damage to balcony seat and/or cylinder liner fittings, recondition all balcony seats and cylinder liner bores to next repair stage. It is imperative to contact MTU and/or DDC.

For limit values, see Tolerance and Wear Limits List.

Check camshaft bearing bushes for wear and damage; replace if necessary.

Check all mating faces, sealing faces and fits; rub down with an oilstone or emery cloth as necessary.

Check bores for dowel pins in crankcase for damage; recondition if necessary.

Check condition of all threads; rechase threads if necessary.

Replace sealing rings.



CAUTION

Compressed air is air which has been compressed under pressure. If compressed air is used for blowing out or blow-drying components, always wear protective goggles or safety mask. Compressed air must not be directed at the body. The pressure must not exceed 3.0 bar (40 lb/in²).

Flush oilways in crankcase with "cleaner", using as high a pressure as possible and blow clear with compressed air.

Note: If the crankcase and/or engine is not put into operation immediately, dry oil bores, preserve and seal air-tight with suitable end covers.

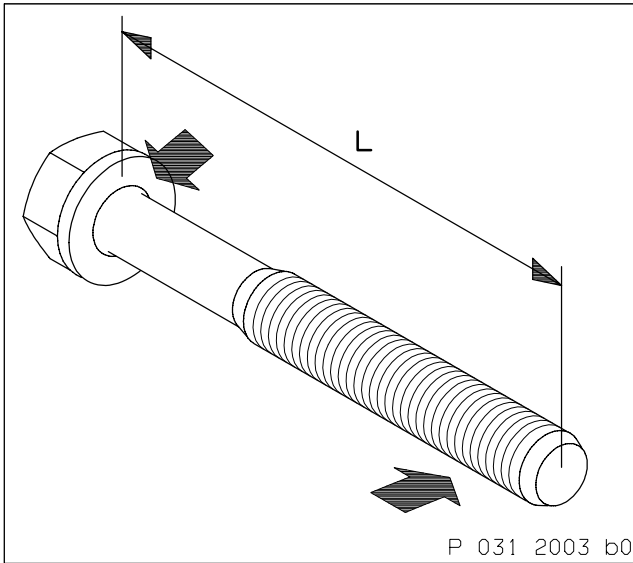

Checking hex screws for crankshaft bearing cap

Measure shaft length (L) of central hex screws for crankshaft bearing cap. For max. shaft length, see C 011.05.01.

Check that thread and screw head mating face (arrows) are in perfect condition; replace screw if necessary.

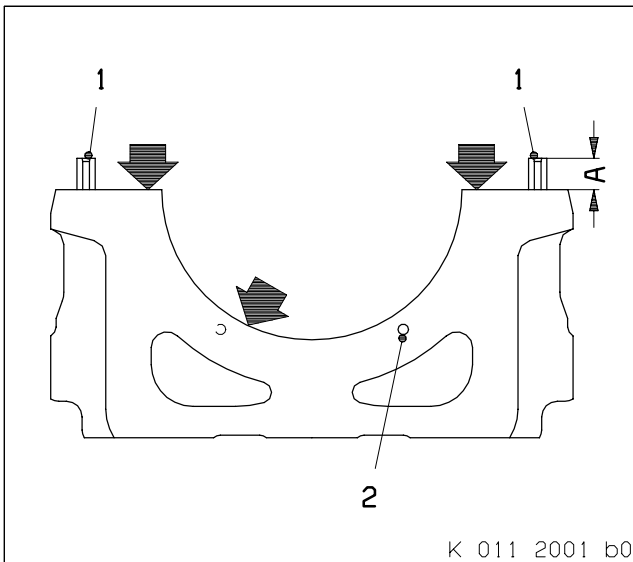

Checking crankshaft bearing cap and crankshaft alignment bearing cover

Using the magnetic crack-testing method and fluorescent magnetic powder, check crankshaft bearing caps for cracks, and replace as necessary.

Check separations and bearing shell mating faces (arrows), both grooved pins (2) and dowel pins (1) in alignment bearing cover and dowel pins in main bearing cap for damage.

Measure projection of cylinder pins, dowel pins and grooved pins.

Projection (A) of cylinder pins and dowel pins = from 12 mm to 13.5 mm

Projection of grooved pins = from 4.5 mm to 4.7 mm

Check position of dowel pins in alignment bearing cover.

Wide end of the dowel pins must face parallel to longitudinal axis of crankshaft main bearing bore.

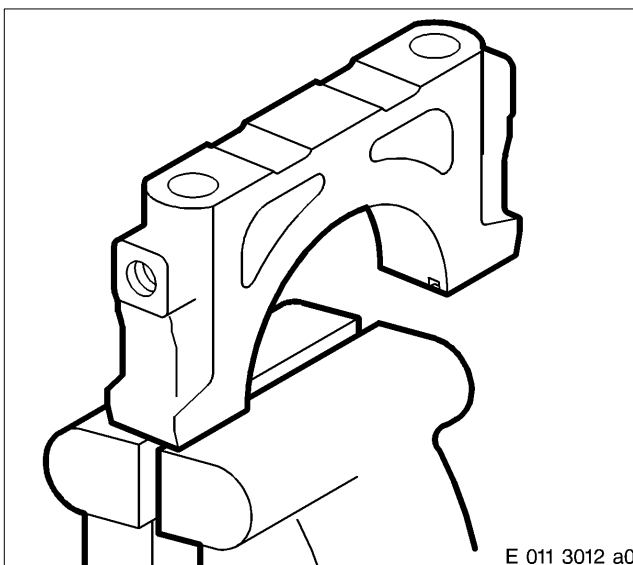

Replacing dowel pins for crankshaft bearing cap

Clamp crankshaft bearing cap on dowel pin in vice and carefully remove dowel pin.

Clean crankshaft bearing cap.

Use a copper hammer to drive in new dowel pin.

Measure projection (A) of dowel pins, see previous illustration.

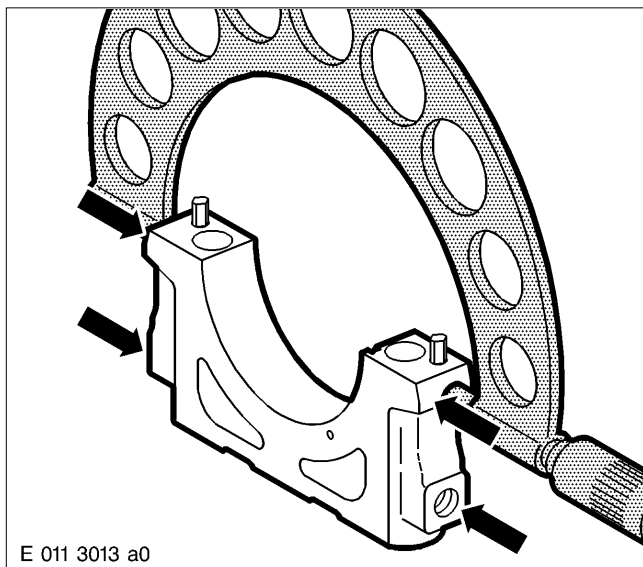

Measuring bearing cap width

Using micrometer, measure width of main bearing cap at upper and lower fits (arrows).

For limit values – see Tolerance and Wear Limits List.

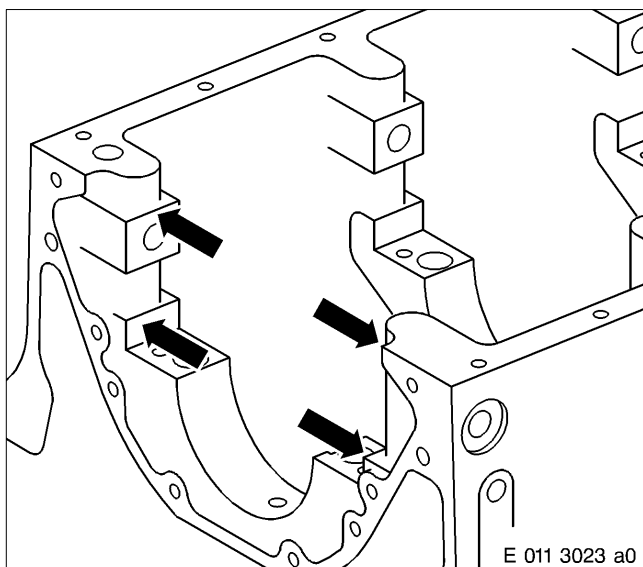

Measuring bearing cap guides

Using bore gauge (1), measure bearing cap guides at upper and lower fits.

For limit values – see Tolerance and Wear Limits List.

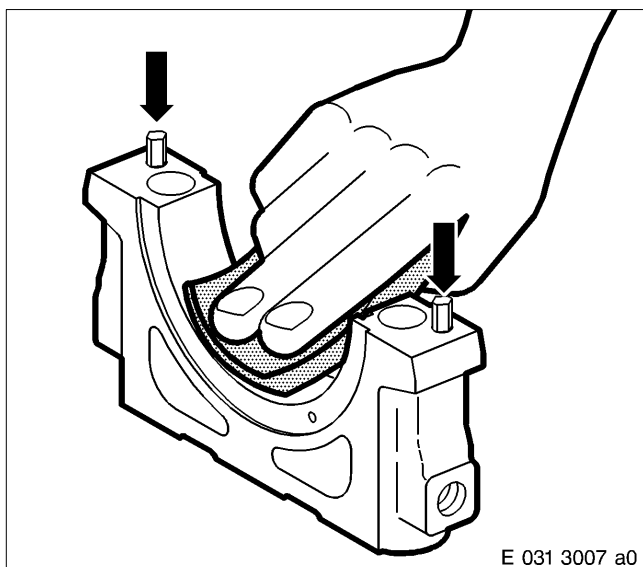

Installing main bearing caps

Crankcase is upside down, with oil pan mating face horizontal.

Wipe bearing shell mating faces on main bearing cap.

CAUTION

Compressed air is air which has been compressed under pressure. Risk of injury!
If compressed air is used for blowing out or blow-drying components, always wear protective goggles or safety mask.
Compressed air must not be directed at the body.
The pressure must not exceed 3.0 bar (40 lb/in²).

Blow out partitions on crankshaft bearing cap and crankcase, cylinder and dowel pins (arrows) and related bores in crankcase with compressed air and check that they are perfectly clean.

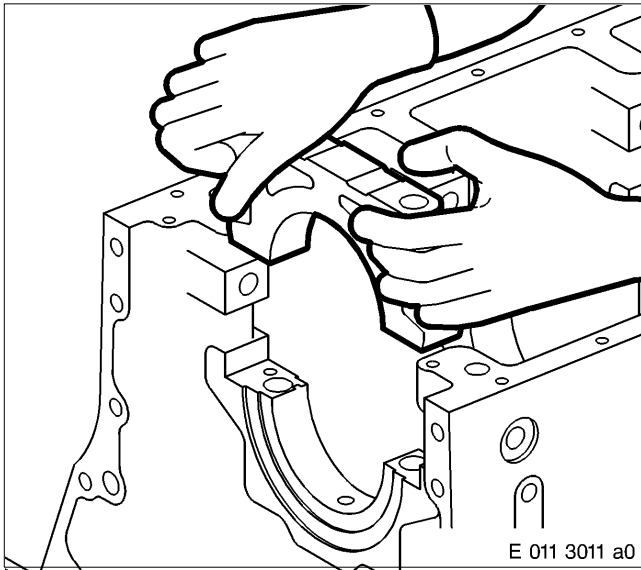

⚠ CAUTION
Components have sharp edges.
Risk of injury!
Handle components only when wearing protective gloves.

Fit bearing caps according to marking, (see next illustration), on appropriate crankcase bearing and secure by hitting with a copper hammer.

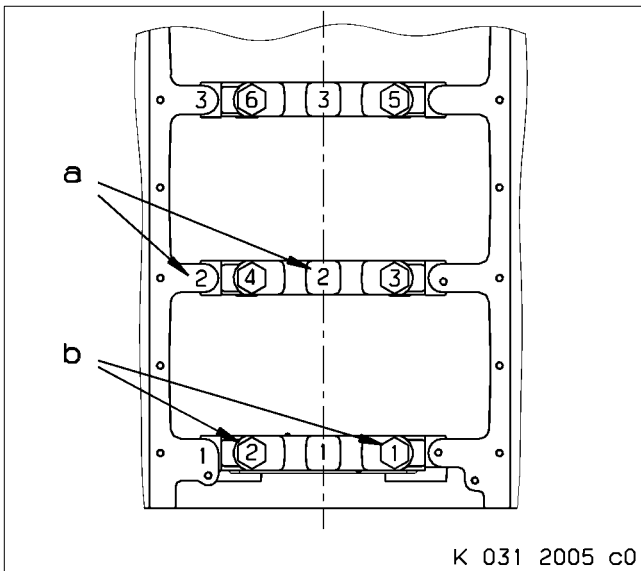

Note: Main bearing caps and their hex screws must not be interchanged.

- a – Consecutive numbering of the main bearing starting from the driving end.
- b – Consecutive numbering of the hex screws.

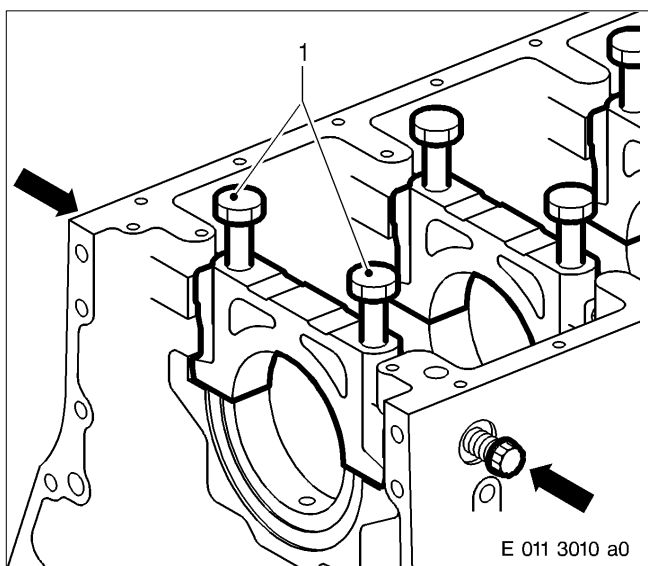

Coat thread and underside of screw of centre hex screws (1) with engine oil.

Fit, but do not yet fully tighten, hex screws as per markings – see previous illustration.

Coat thread and mating face of side double-hex screws (arrows) with engine oil and insert double-hex screws but do not tighten yet.

Note: Always tighten screws on one bearing at same time.
Tightening sequence starts from alignment bearing.

Pretighten centre screws to specified pretightening torque – see C 011.05.01.

Mark screw heads.

Tighten screws to specified additional angle of rotation.

Note: Tighten lateral double-hex screws of one bearing simultaneously.

Simultaneously tighten side double-hex screws, starting from alignment bearing, in one work step to specified torque – see C 011.05.01.

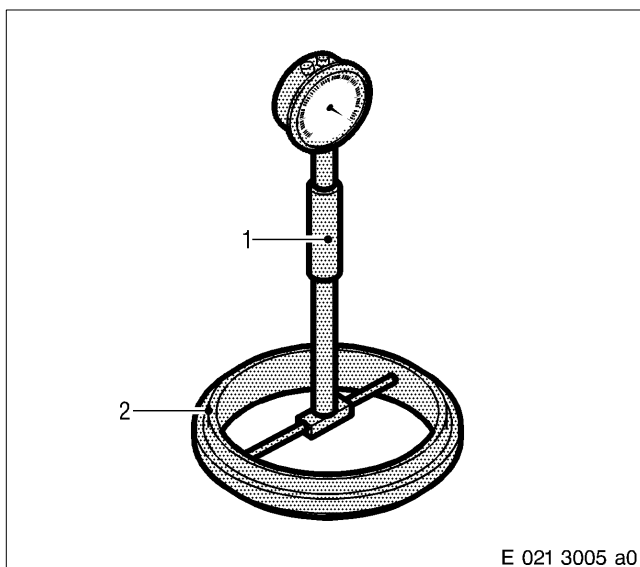

Setting bore gauge

Adjust bore gauge (1) and dial gauge with adjusting ring (2) or micrometer to basic size of respective bore to be measured.

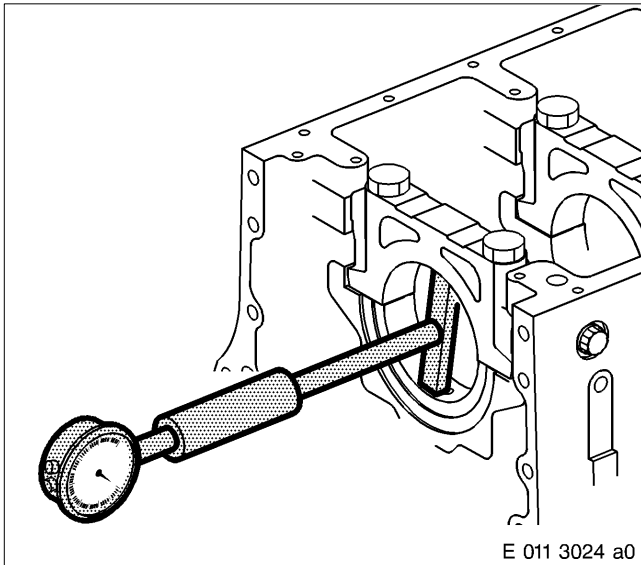

Measuring crankshaft main bearing bore

Using bore gauge, measure crankshaft main bearing bore.

Enter measurement values in data sheet.

For measurement planes and limit values, see Tolerance and Wear Limits List.

If limit values are exceeded, machine locating bore in question to repair size.

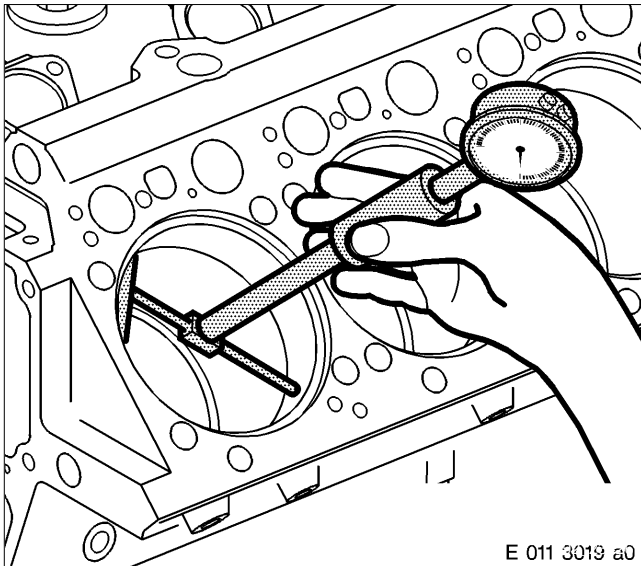

Measuring crankcase bores for cylinder liners

Using bore gauge, measure upper and lower fits of cylinder liner locating bores.

Enter measurement values in data sheet.

For limit values, see Tolerance and Wear Limits List.

If limit values are exceeded, machine all collared bush recesses and cylinder liner bores in question to next repair size.

It is imperative to contact MTU and/or DDC.

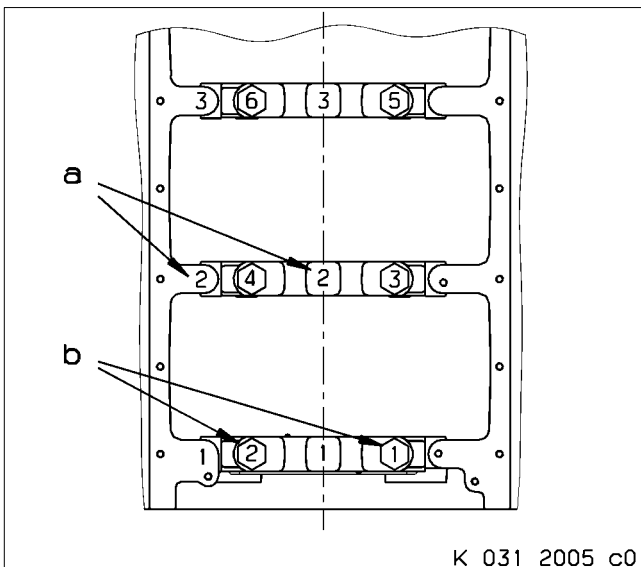

Removing main bearing caps

Crankcase is upside down, with oil pan mating face horizontal.

Check marking of main bearing cap in respect to crankcase and consecutive numbering of hex screws, and apply marks as necessary.

a – Starting at driving end, stamp number of main bearing with 6 mm numbers main bearing so that they can be read from same direction.

b – Consecutive numbering of the hex screws.

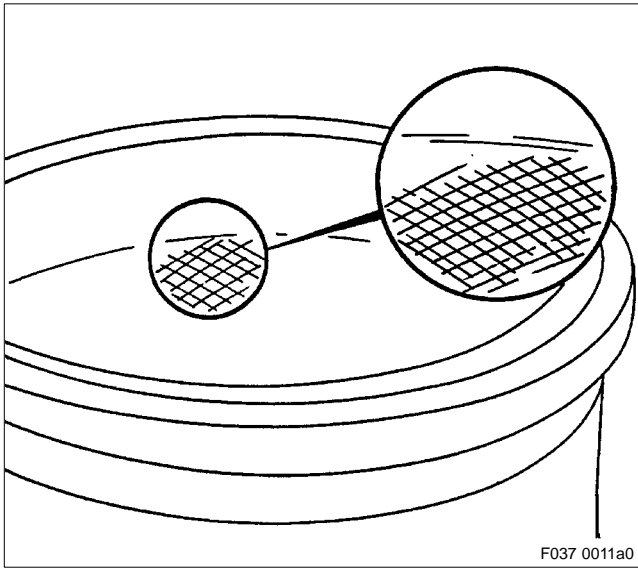

F037 0011a0

When reusing cylinder liners which have not been re-honed, the honing must be more or less clearly recognisable over entire running surface.
Isolated minor grooves are insignificant.
There must be no signs of wear at reversing point of initial piston ring.

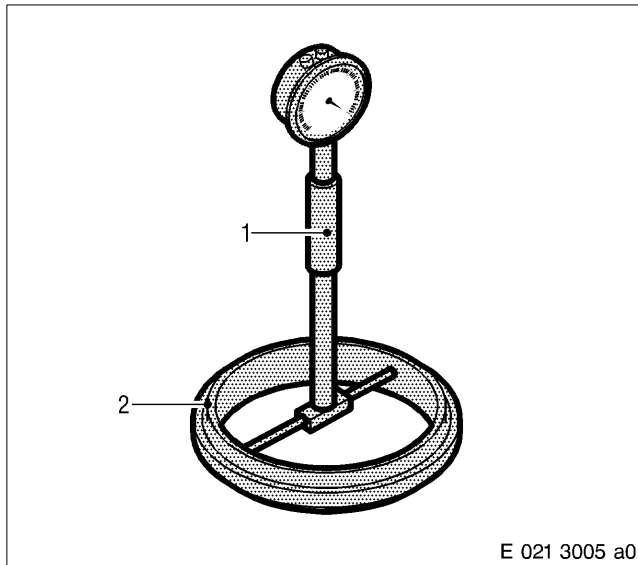

E 021 3005 a0

Measuring cylinder liner ID

Adjust bore gauge (1) and dial gauge with micrometer or gauge ring (2) to basic size for cylinder liner as per Tolerance and Wear Limits List.

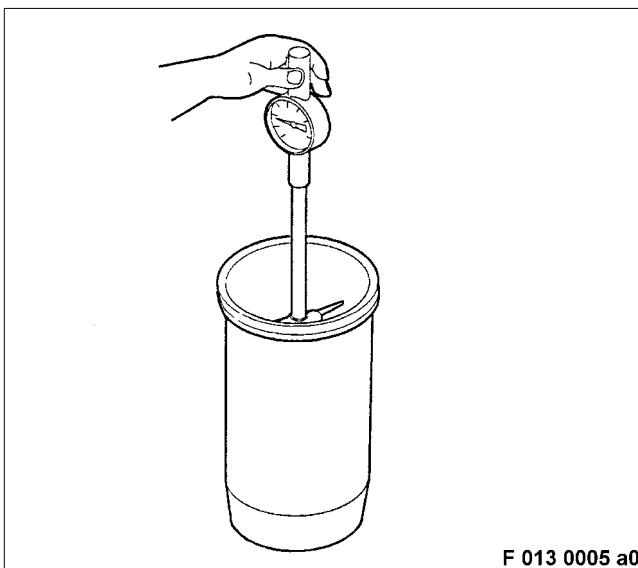

F 013 0005 a0

Measure cylinder liner ID with bore gauge.
For measuring points and limit values, see Tolerance and Wear Limits List.
Replace cylinder liner if measured values are exceeded.

C 013.05.11 Installation

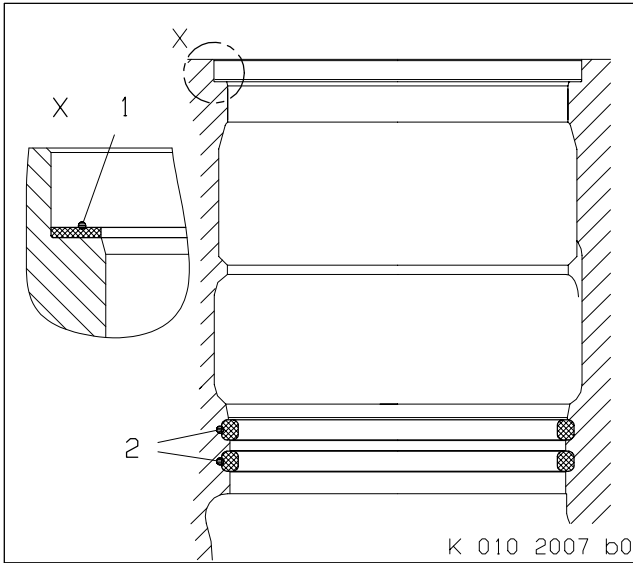

Installing cylinder liner

Coat new sealing rings (2) with petroleum jelly and insert into grooves in crankcase.

Fit new Tombak ring (1) on cylinder liner collar seat in crankcase.

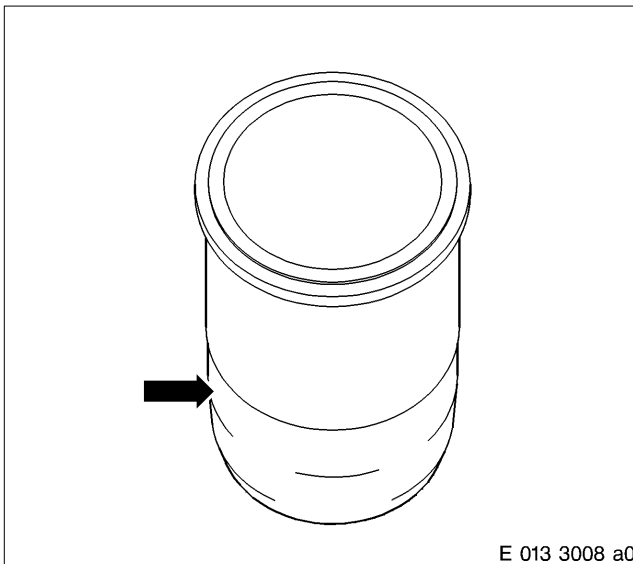

Check cylinder liner repair stage as per Tolerance and Wear Limits List and assign according to crankcase data sheet.

Note: The tolerance group designation is stamped on the edge of the liner.

Wipe cylinder liner at lower fit (arrow) and at chamfer inclination; then lightly coat with petroleum jelly.

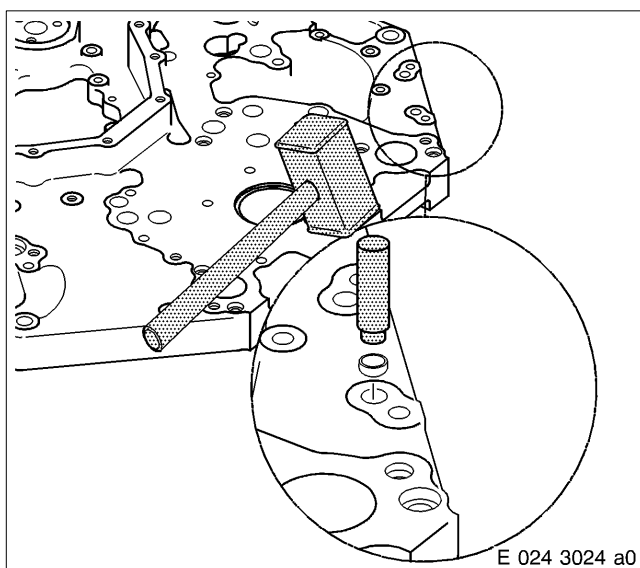

Clean and degrease seating faces of cover and bore gear case, free end.

Coat seating face of cover with thread locking compound.

Using a mandrel and hammer, drive cover into bore until flush.

Note: Ensure correct final strength of thread-locking agent, see C 020!

Replacing pipe in gear case, free end

Note: Only replace pipe when necessary (e.g. if damaged). Pipe is secured with thread-locking liquid.

Heat pipe to approx. 130 °C and withdraw from the gear case, driving end, see C 024.05.01.

Clean and degrease seating faces on pipe and bore in gear case.

Coat seating face of pipe with thread-locking agent.

Insert pipe into bore until it contacts the stop.

Note: Ensure correct final strength of thread-locking agent, see C 020!

C 024.05.11 Installation

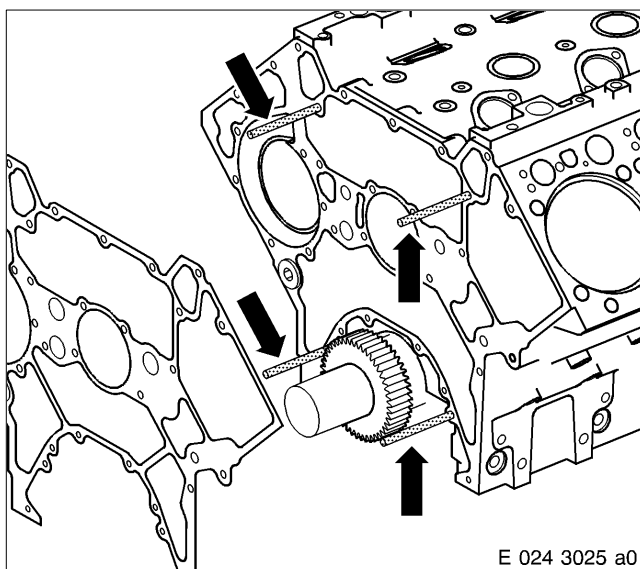

Installing gear case

Clean mating face on crankcase and gear case, free end.

For positioning the gaskets, apply a thin, dotted coat of sealing paste to the mating surfaces of the crankcase.

Insert suitable guide pins (arrows) into crankcase.

Place new gasket on top of the guide pins.

Adjust gasket lengthwise at the oil pan mating surface (cut off).

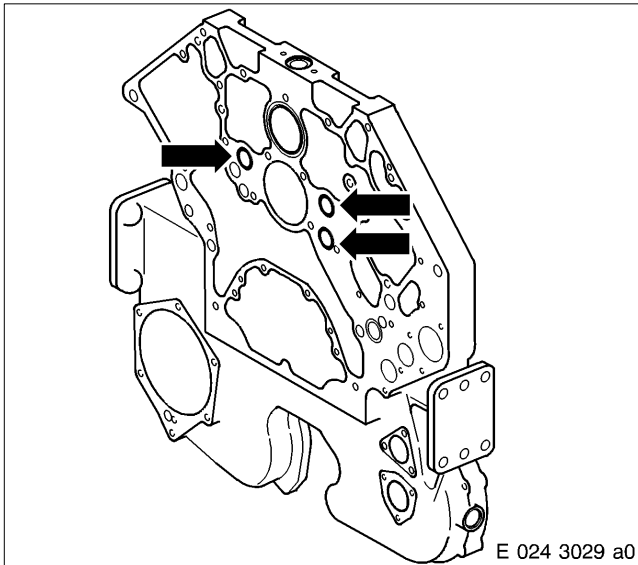

Coat sealing rings (arrows) with petroleum jelly and insert in grooves on gear case.

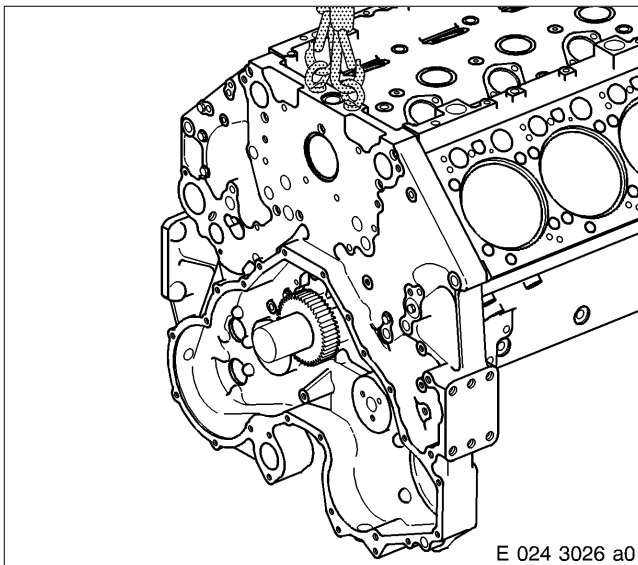

 WARNING
<p>Suspended load. Risk of injury! Only use lifting device provided by manufacturer and observe lifting instructions. Never stand beneath a suspended load.</p>

Screw lifting eyes into gear case and secure to crane with rope.

Carefully move gear case with crane via guide pins on crankcase.

Remove lifting ropes and eyes.

Note: Take note of markings of the screws and note that screws differ in length.

Install all securing screws and tighten uniformly.

Cut projecting gasket so that it is flush with oil pan sealing surfaces.

Note: Ensure correct final strength of surface sealant, see C 020!

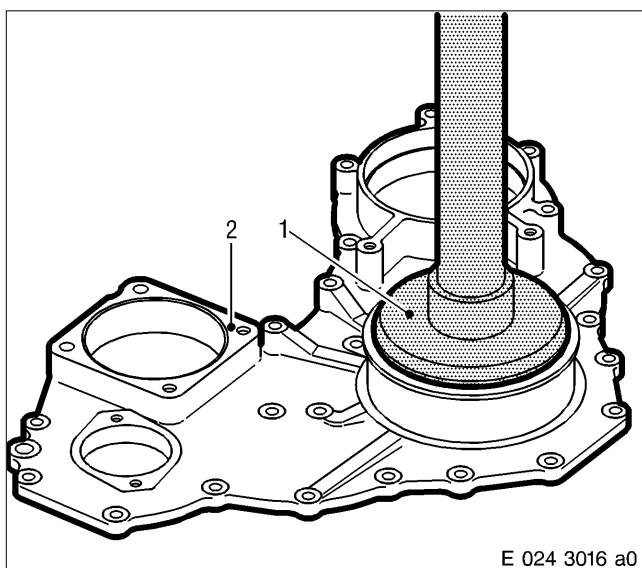

Completing and installing gear case cover

Fit radial-lip shaft seal, with sealing lip facing downwards, on press-in mandrel (1).

Coat sealing face of radial-lip oil seal with denaturated ethanol.

Note: Denaturated ethanol acts as lubricant for press-fitting.

Clean and degrease sealing face for radial-lip oil seal in gear case cover (2).

Press-fit radial-lip shaft seal with drift into gear case cover.

Note: Radial-lip shaft seal clearance in gear case cover is 7 to 9 mm.

Install shock damper, see C231.05.

Install intermediate gears and axles, see C 025.05.01.

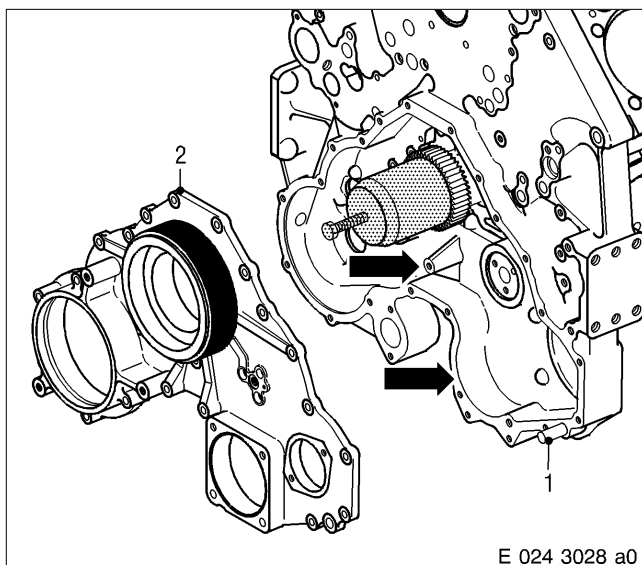

Back off jackscrew on alignment tool, mount the alignment tool on the crankshaft and press on by hand in direction driving end.

Clean and degrease mating faces (arrows) of gear case and coat with surface sealant.

Insert centering pin (1) into gear case (flat end of centering pin facing crankshaft centreline).

Clean and degrease mating face on gear case cover (2).

Carefully move gear case cover via alignment tools on gear case.

Screw in all securing screws as shown in Overview – Drawing see C 024.05.01 and tighten uniformly.

Note: Make sure components are reinstalled in accordance with markings, and note that screws differ in length.

Press off alignment tool from crankshaft using jack-screw.



C 024.05.12 After-Installation Operations

A distinction must be made as to whether:

- 1 ————— The engine was completely disassembled
- 2 ————— The engine is removed but was not disassembled
- 3 ————— The engine is installed

1	2	3	Operations	See
x	—	—	Perform operations as per Assembly Plan	B 005
x	—	—	Install engine	B 007
—	x	x	Install oil pan	C 014.05
—	x	x	Install engine mount, free end	C 231.05
—	x	x	Install coolant control housing	C 206.05
—	x	x	Install fan drive	C 221.05
—	x	x	Install generator	C 213.05
—	x	x	Press on flange, free end	C 035.05
—	x	x	Install vibration damper	C 035
—	x	x	Install engine coolant pump	C 202.05
—	x	x	Install charge air coolant pump	—
—	x	x	Install air compressor	C 362.40
—	x	x	Install fuel delivery pump	C 081.05
—	x	x	Connect coolant lines	C 202.15
—	x	x	Install fuel lines	C 082.05/C 084.05
—	x	x	Install fuel duplex filter	C 083.05
—	x	x	Install oil lines	C 181.20
—	x	x	Install V-belt	C 028.05
—	x	x	Connect electric cables	—
—	—	x	Fill oil system with engine oil	Operating Instructions
—	—	x	Fill engine coolant system	Operating Instructions
—	—	x	Check engine alignment; realign engine if necessary	Special Publication
—	—	x	Release engine start	Operating Instructions

C 025.05 Gear Train, Free End

C 025.05.01 Overview Drawing

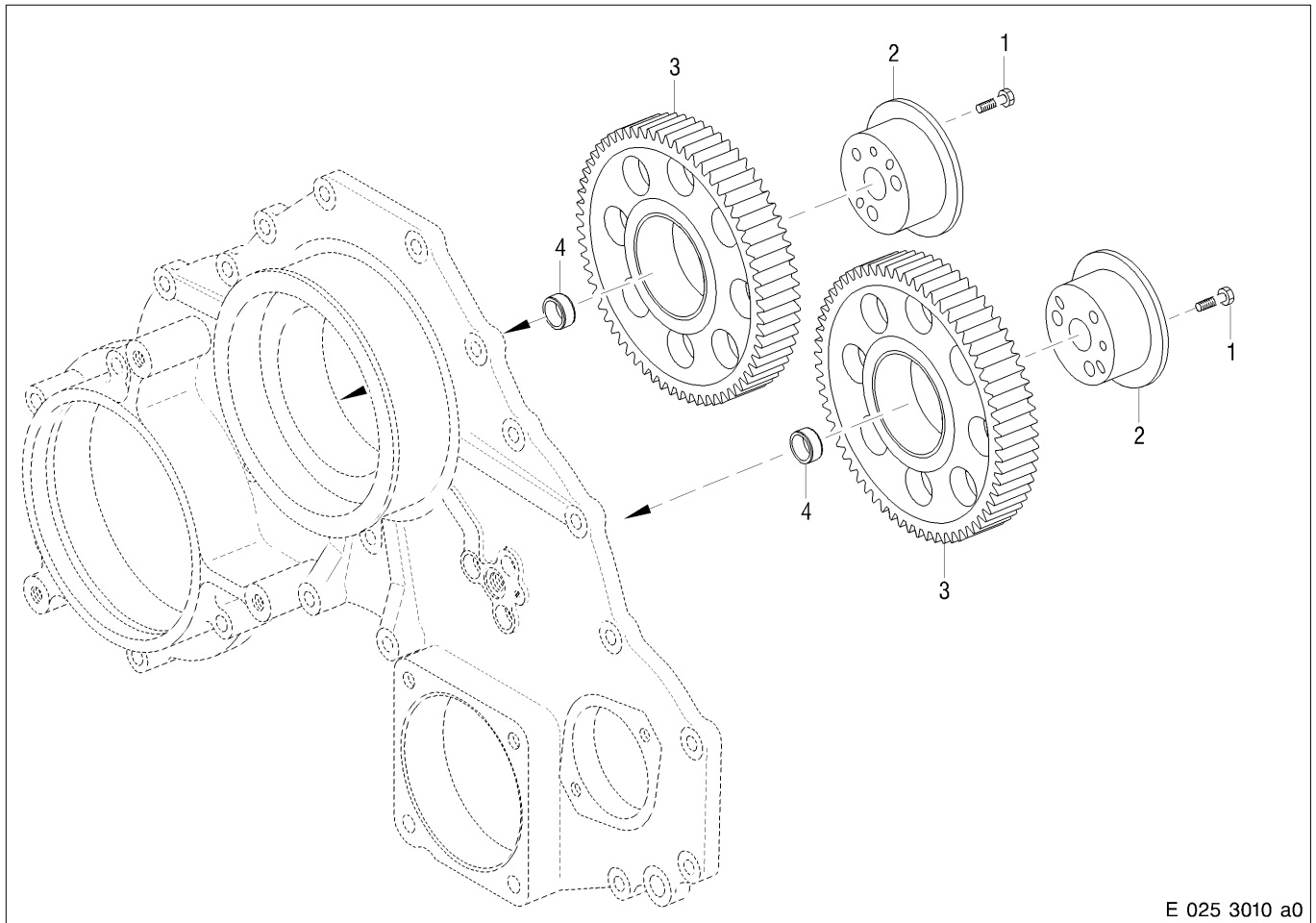

- 1 Hex screw
- 2 Axle
- 3 Idler gear
- 4 Sleeve

C 025.05.02 Special Tool

Designation – Application

Number

Press-in mandrel for sleeve

1

C 025.05.04 Before-Removal Operations

A distinction must be made as to whether:

- 1 ————— The engine is to be completely disassembled
- 2 ————— The engine is to be removed but not disassembled
- 3 ————— The engine is to remain installed

1	2	3	Operations	See
x	-	-	Remove engine	B 003
x	-	-	Perform operations as per Disassembly Plan	B 004
-	-	x	Disable engine start	Operating Instructions
-	-	x	Drain engine coolant	Operating Instructions
-	-	x	Drain charge air coolant*	-
-	-	x	Drain or draw off engine oil	Operating Instructions
-	x	x	Disconnect fuel lines	C 082.05/C 084.05
-	x	x	Disconnect electric wiring	-
-	x	x	Remove fuel delivery pump	C 081.05
-	x	x	Remove V-belt	C 028.05
-	x	x	Remove coolant lines	C 202.15
-	x	x	Remove engine coolant pump	C 202.05
-	x	x	Remove charge air coolant pump*	-
-	x	x	Remove vibration damper	C 035.05
-	x	x	Remove flange, free end	C 035.05
-	x	x	Remove oil lines	C 181.20
-	x	x	Remove generator	C 213.05
-	x	x	Remove gear case cover	C 024.05

* – not always applicable (order-specific)

C 025.05.05 Removal

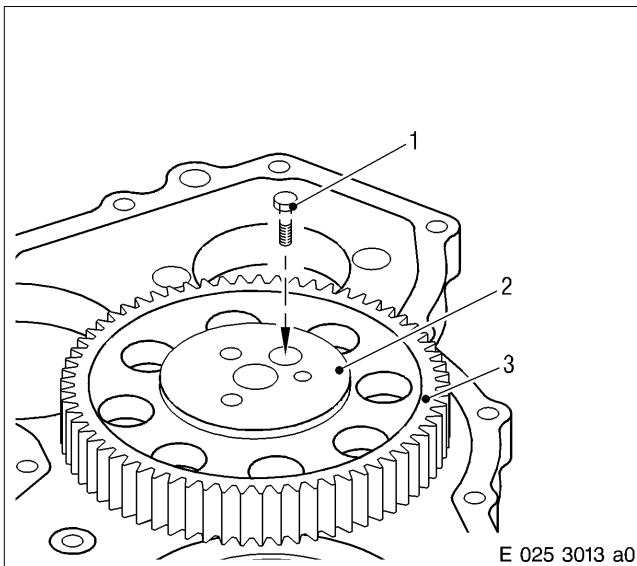

Removing intermediate gears and axles

Mark idler gears and axles according to installation point.

Remove hex screw (1) and pull axle (2) with idler gear (3) from the sleeve.

Remove sleeve from gear case cover.

C 031.05.04 Before-Removal Operations

A distinction must be made as to whether:

- 1 ————— The engine is to be completely disassembled
- 2 ————— The engine is to be removed but not disassembled
- 3 ————— The engine is to remain installed

1	2	3	Operations	See
x	-	-	Remove engine	B 003
x	-	-	Perform operations as per Disassembly Plan	B 004
-	x	x	Removal of crankshaft not scheduled	-

C 031.05.05 Removal

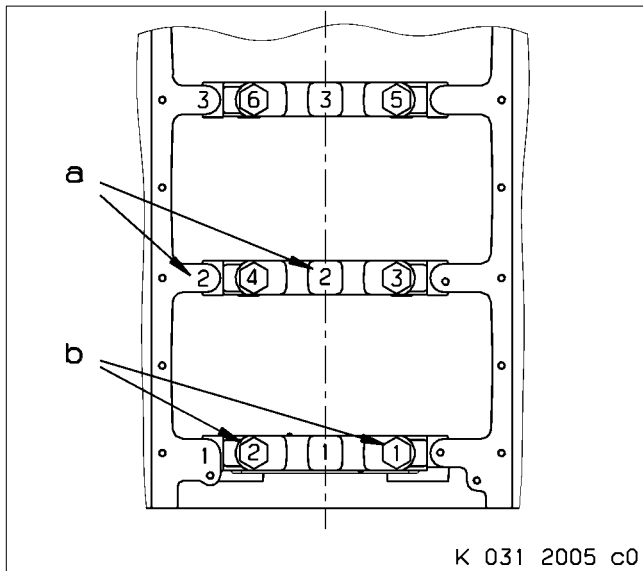

Checking markings of main bearing cap and hex screws

Check marking of main bearing cap in respect to crankcase and consecutive numbering of hex screws, and apply marks as necessary.

- a – Starting at driving end, stamp number of main bearing with 6 mm numbers main bearing so that they can be read from same direction.
- b – Consecutive numbering of the hex screws.

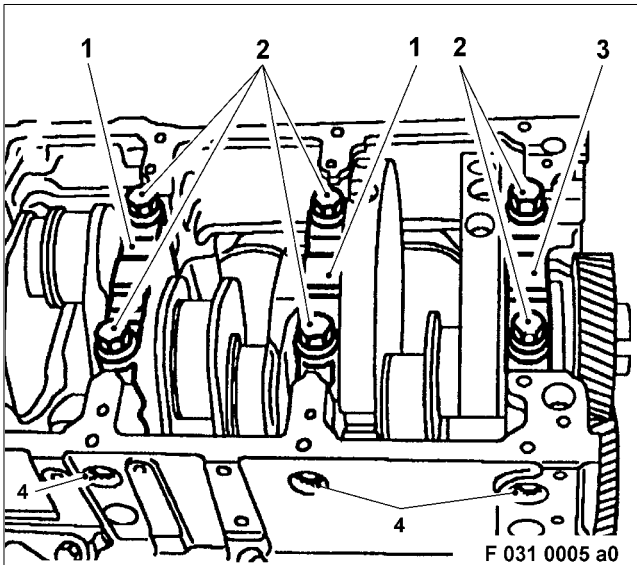

Removing main bearing caps

Crankcase is upside down, with oil pan mating face horizontal.

Using a ratchet and socket, remove all side double-hex screws (4) for alignment bearing cover (3) and crankshaft bearing cap (1).

Remove central hex screws (2) for crankshaft bearing cap with ratchet and socket.

Note: Release screws on one bearing at same time.

CAUTION

**Components have sharp edges.
Risk of injury!
Handle components only when wearing protective gloves.**

Carefully raise all bearing caps vertically until clear of crankcase.

Mark bearing shell of respective bearing cap and remove.

Note: Protect bearing shells from damage!

Remove friction washers from crankshaft alignment bearing cap.

Removing crankshaft

To protect crankshaft, insert four assembly screws on first and last bearing.

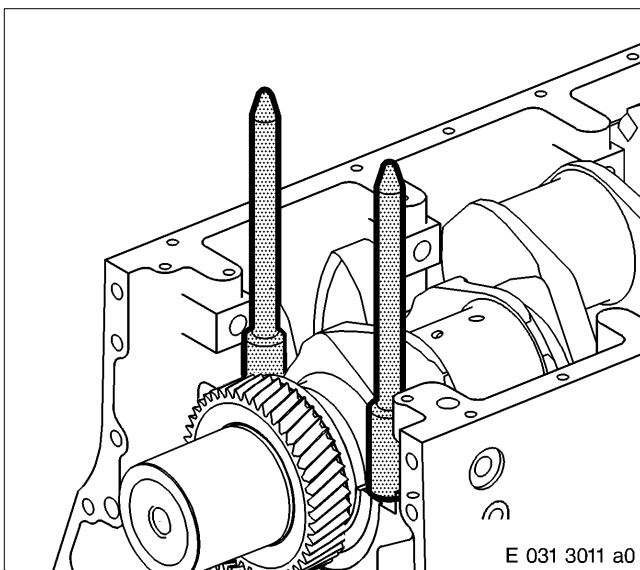

C 031.05.08 Inspection and Repair

Cleaning and checking crankshaft

Clean crankshaft with cold cleaner.



CAUTION

Compressed air is air which has been compressed under pressure. If compressed air is used for blowing out or blow-drying components, always wear protective goggles or safety mask. Compressed air must not be directed at the body. The pressure must not exceed 3.0 bar (40 lb/in²).

Using suitable bottle brush and cold cleaner, thoroughly clean all crankshaft bores and blow through with compressed air.

Note: Never use a wire brush!

Check taper surface (free end) for scoring and damage.

Remove minor scoring and damage by polishing with emery cloth.

Check taper 1 : 50 with taper gauge.

If necessary, machine taper to MTU/DDC specifications.

Check that all threads are in perfect condition.

Check teeth of gear (free end) for wear, indentations and chipping.

Remove minor wear, indentations and scoring by rubbing down with emery cloth or an oilstone; replace gear if necessary.

Check counterweight mating faces for wear; machine-grind if necessary. It is imperative to contact MTU and/or DDC.

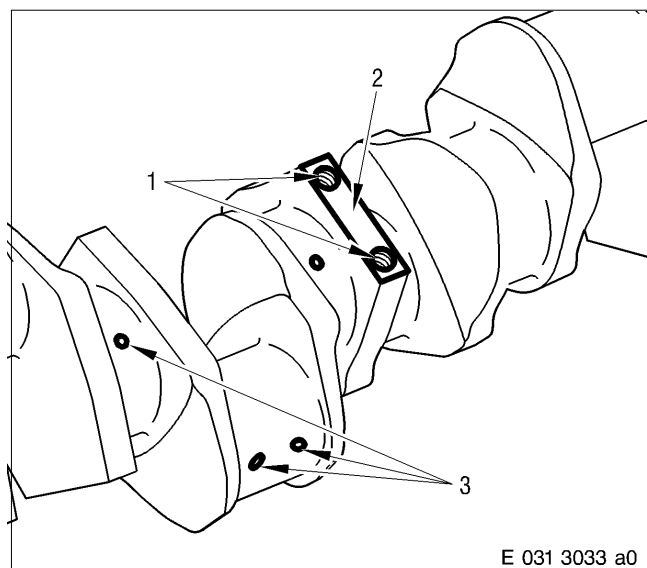

Checking crankshaft for cracks

Using the magnetic crack-testing method with fluorescent magnetic powder, check crankshaft for longitudinal and transverse cracks. Include oil bores and journal bores (3), journal transition radii, counterweight mating faces (2) and threaded bores (1) in scope of inspection.

Install crankshaft in longitudinal direction between jaws of test device.

For the test, a magnetic electric field strength of 20 A/cm to 60 A/cm must be applied at every part of the component.

Demagnetize crankshaft after crack-testing. The maximum permissible residual field strength after demagnetization is 2.5 A/cm to 4 A/cm.

Note: A component is considered sufficiently demagnetized when a paper clip suspended on a thread is no longer attracted by the component.

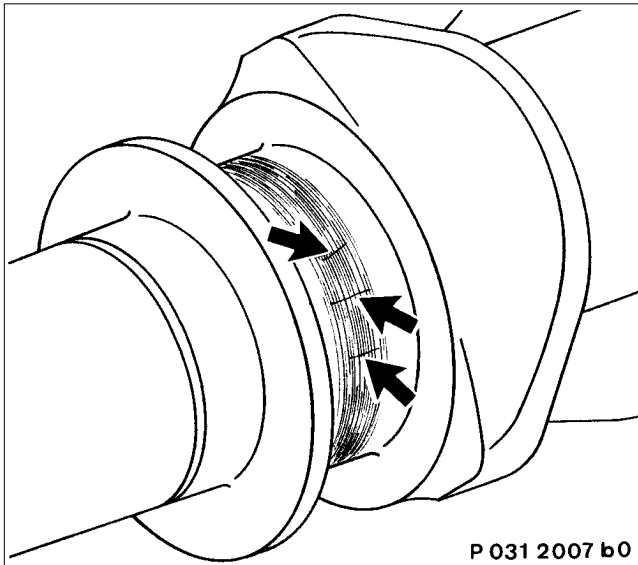

Information on thermal cracks

Characteristic of hot-running cracks is that they are almost always parallel to the axis of the component (see arrows).

Transverse cracks sometimes come out from these cracks. Heavy thermal cracks are mostly of a depth approximately corresponding to the thickness of the hardness layer. Replace crankshaft with such cracks.

Crankshafts exhibiting minor hot-running cracks can be repaired. This is provided that regrinding to a repair stage or local grinding will remove the damage. It is imperative to contact MTU and/or DDC.

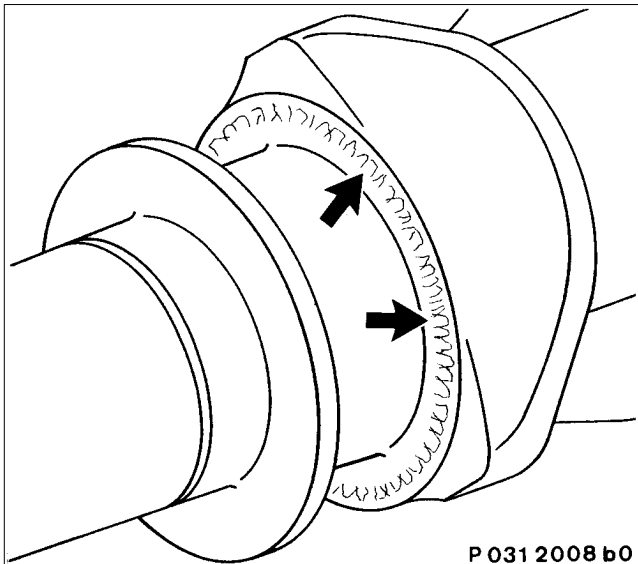

Information on grinding cracks

Fine branching is characteristic of thermal cracking, (arrows). The illustration shows a bearing journal with grinding cracks.

Replace crankshaft with such cracks.

Grind cracks occur on account of insufficient cooling during grinding or through excessive feed.

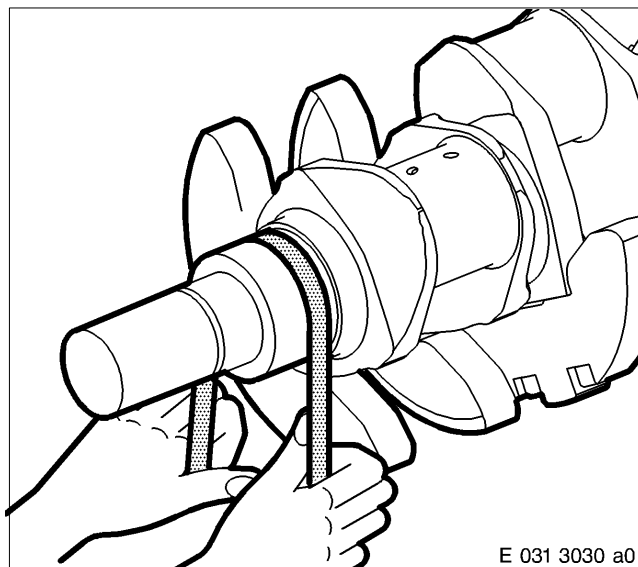

Checking crankshaft journal

Burnish all journals with emery cloth (granulation P 320).

Standardised roughness height (R_z) of journal sliding surface = 1 μm

Polish all fillets and transitions.

Check main bearing and crankpin surfaces for scoring and damage. If necessary, regrind relevant journal to next repair stage.

Check friction washer sliding surface of first main bearing for wear. Regrind to next repair stage if necessary.

For limit values, see Tolerance and Wear Limits List.

Remove minor scoring and damage by polishing with emery cloth.

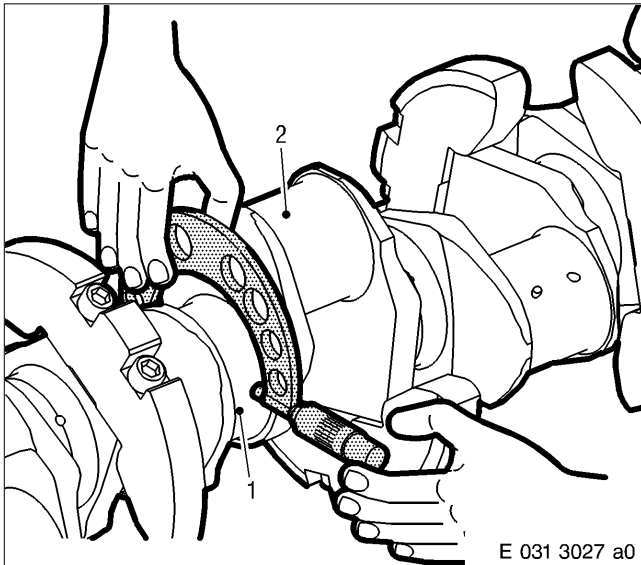

Measuring crankshaft journal

Using micrometer, measure bearing journals (1) and crankpins (2) of crankshaft for out-of-round and surface irregularities; record measured values in Data Sheet.

For limit values, see Tolerance and Wear Limits List.
If limit values are exceeded, grind crankshaft to next repair size.

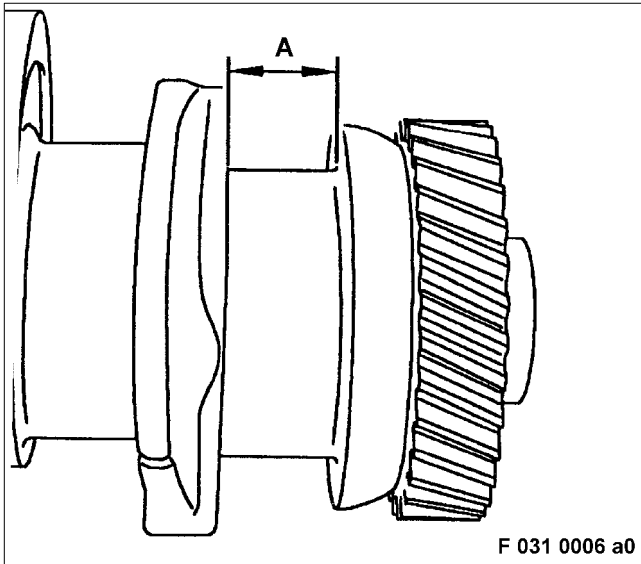

Measure width of alignment bearing (A) with inside micrometer and enter values in Data Sheet.

For limit values, see Tolerance and Wear Limits List.
If limit values are exceeded, grind crankshaft to next repair size.

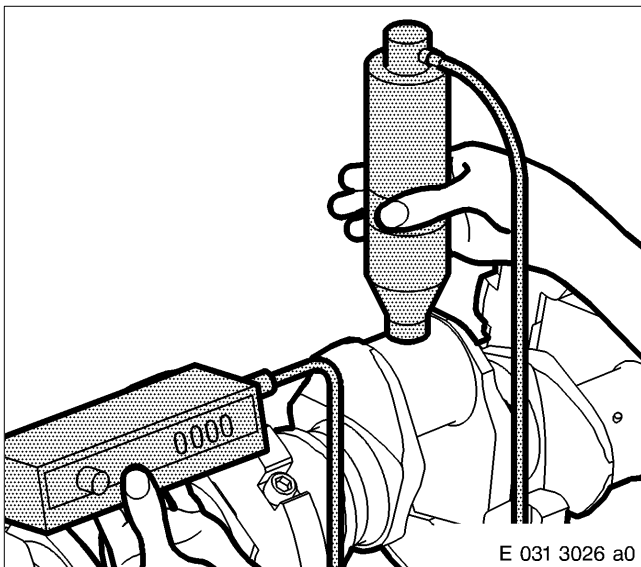

Checking hardness of journals

Check hardness of all journals using the Microdur tester or other suitable hardness tester.

Test hardness of each journal at four points at 90° intervals around circumference.

Specified hardness = from 49 HRC to 53 HRC

Replace crankshaft if a bearing journal has lost its hardness on account of bearing scuffing.

Checking crankshaft concentricity

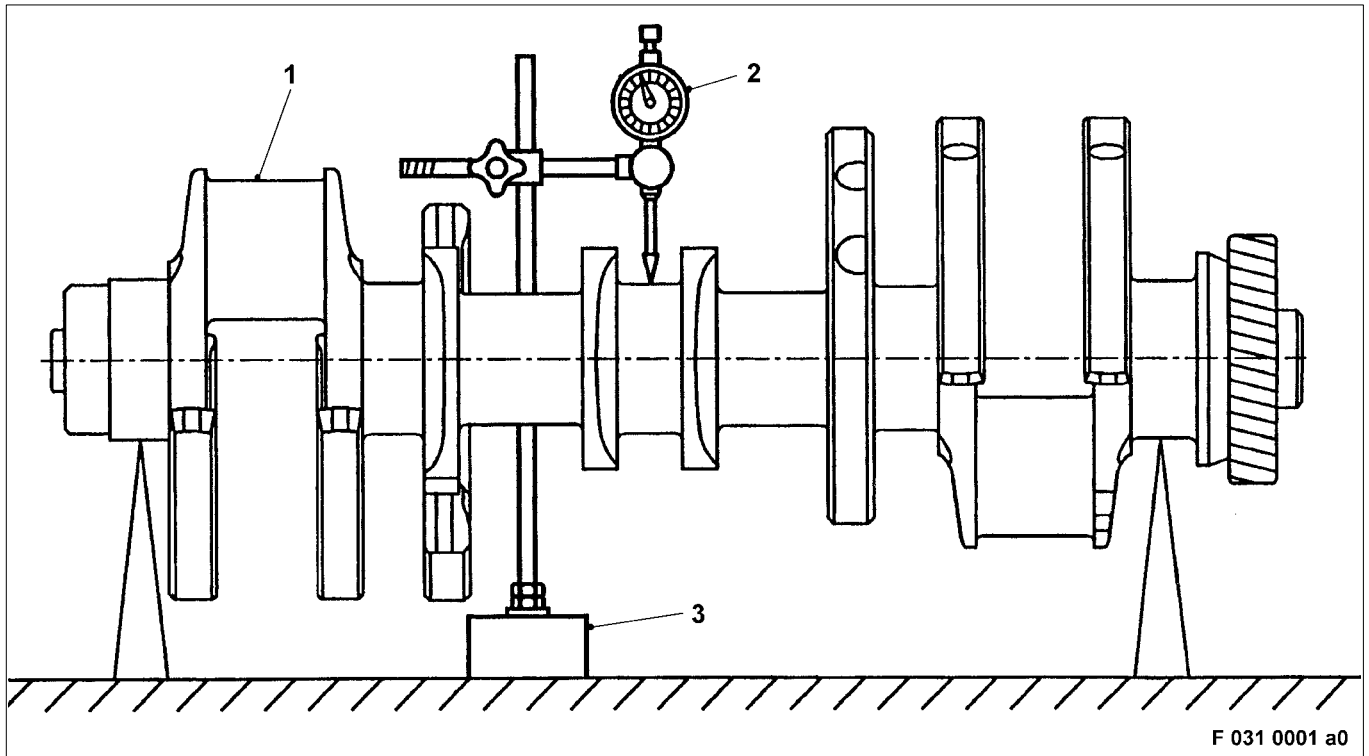

Place crankshaft (1) on the outer bearing journals.

Using a magnetic-base indicator holder (3) and dial gauge (2), check concentricity of bearing journals.

If wear across circumference of journal is irregular, check at transition from cylindrical section of journal to radius.

For limit values, see Tolerance and Wear Limits List.

If measured values differ from those specified in Tolerance and Wear Limits List, grind relevant journals to next repair stage.

Note: Do not straighten crankshaft!

Always consult DDC or MTU before grinding crankshaft journals.

Crankshaft mounting

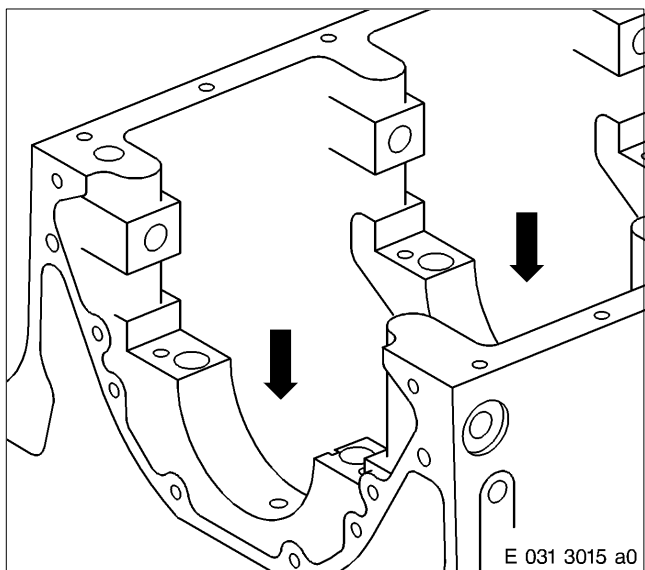

Installing bearing shells

Note: Always make sure that all components are perfectly clean.

Crankcase is upside down, with oil pan mating face horizontal.

Wipe bores (arrows) for crankshaft bearing in crankcase and bearing shells on both sides.

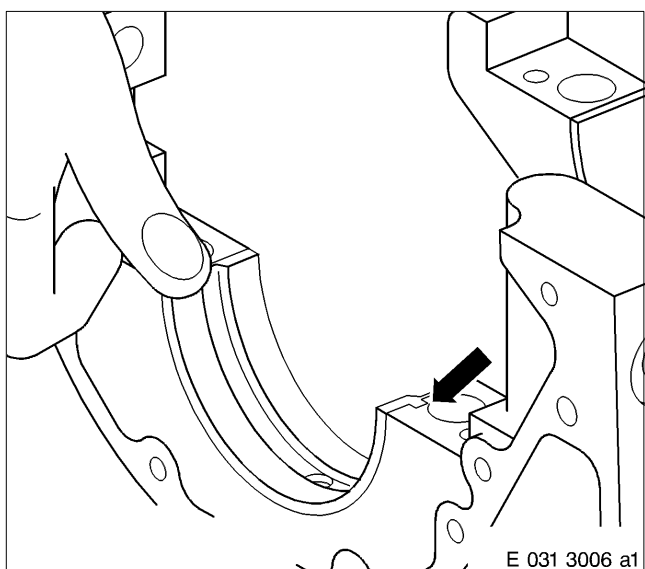

Note: Top and bottom bearing shells have different part numbers.

Check codes for repair stage and journal diameter on new bearing shells and bearings numbers on run-in bearing shells

Compare crankcase inspection sheet with crankshaft data sheet.

Manually insert bearing shells (bearing shells with oil groove and oil bore) on housing side in accordance with bearing number into housing bore to form a positive connection.

Securing lug (arrow) of bearing shell must sit in groove in crankcase.

Oil bores in bearing shells and crankcase must be aligned.

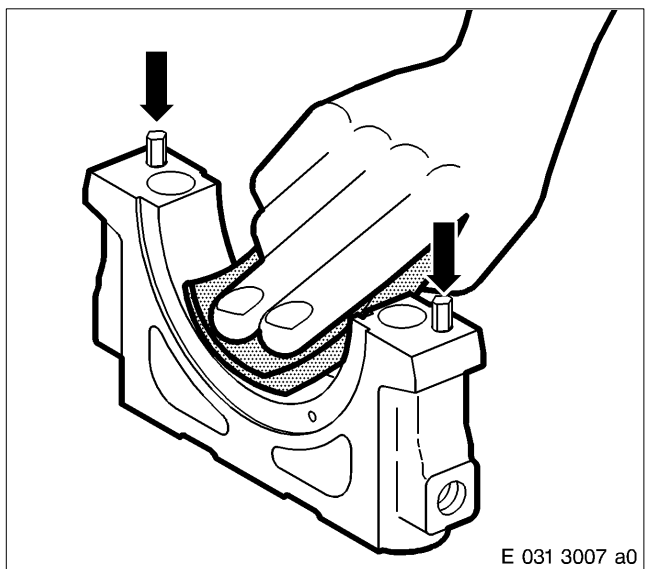

Installing main bearing caps

Wipe bearing shell mating faces on main bearing cap.

CAUTION

Compressed air is air which has been compressed under pressure. Risk of injury!
If compressed air is used for blowing out or blow-drying components, always wear protective goggles or safety mask.
Compressed air must not be directed at the body.
The pressure must not exceed 3.0 bar (40 lb/in²).

Blow out partitions on crankshaft bearing cap and crankcase, cylinder and dowel pins (arrows) and related bores in crankcase with compressed air and check that they are perfectly clean.

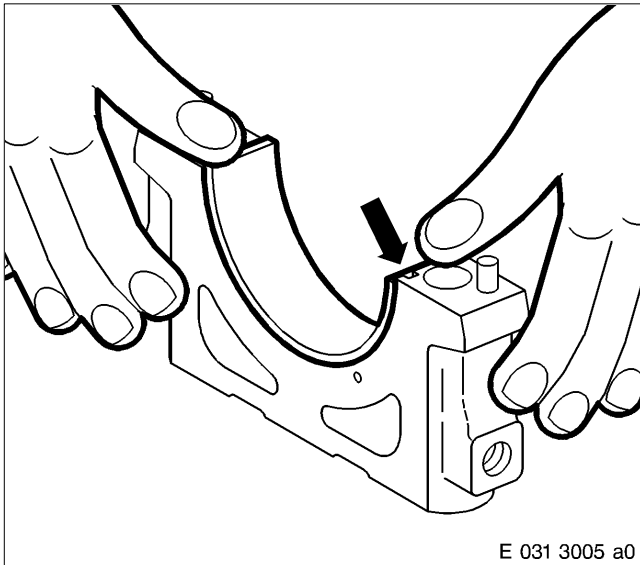

E 031 3005 a0

Wipe bearing shell on both sides and insert into main bearing cap according to markings or bearing number.

Securing lug (arrow) of bearing shell must sit in groove in crankshaft bearing cap.

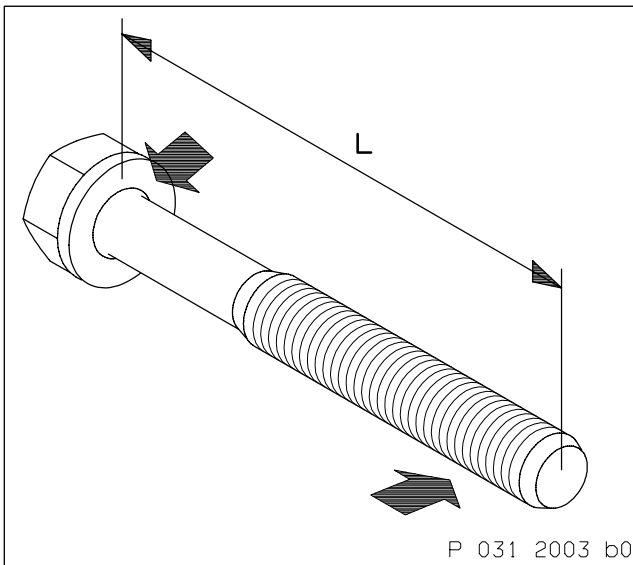

P 031 2003 b0

Measure shaft length (L) of central hex screw for crankshaft bearing cap. For max. shaft length – see C 031.05.01.

Coat thread and screw head mating face of centre hex screws (arrows) with engine oil.

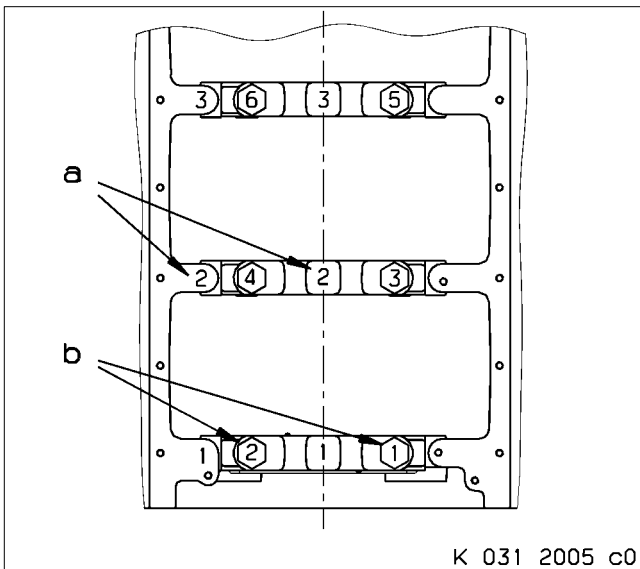

K 031 2005 c0

Note: Main bearing caps and their hex screws must not be interchanged.

CAUTION

**Components have sharp edges.
 Risk of injury!
 Handle components only when wearing protective gloves.**

Match bearing cap in accordance with crankcase marking to bearing cap and insert into crankcase.

a – Consecutive numbering of the main bearing caps starting from the driving end.

b – Consecutive numbering of the hex screws.

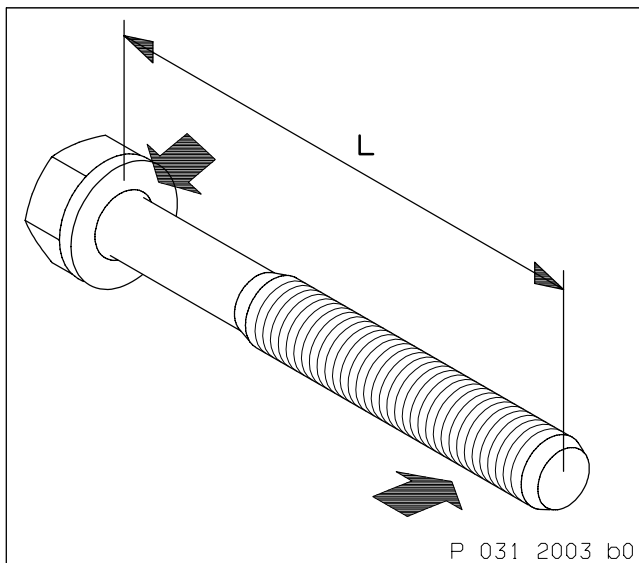

Measure shaft length of central hex screws for crankshaft bearing cap. For max. shaft length (L), see C 031.05.01.

Coat thread and screw head mating face of centre hex screws (arrows) with engine oil.

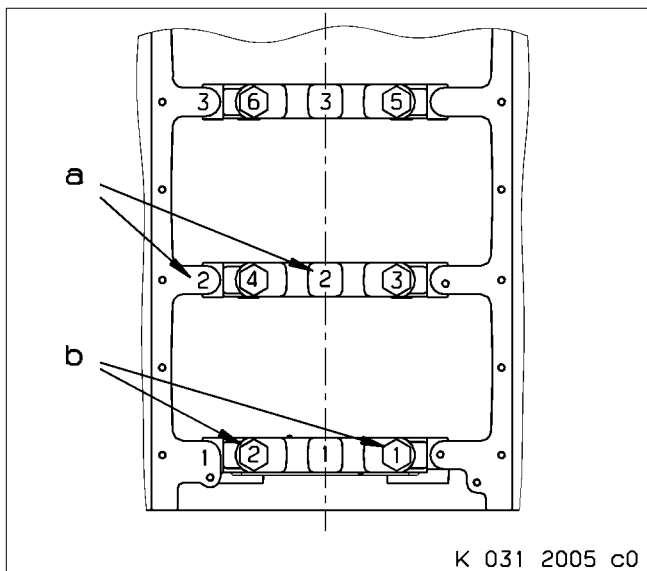

Note: Main bearing caps and their hex screws must not be interchanged.

CAUTION
Components have sharp edges. Risk of injury! Handle components only when wearing protective gloves.

Match bearing cap in accordance with crankcase marking to bearing cap and insert into crankcase.

- a – Consecutive numbering of the main bearing starting from the driving end.
- b – Consecutive numbering of the hex screws.

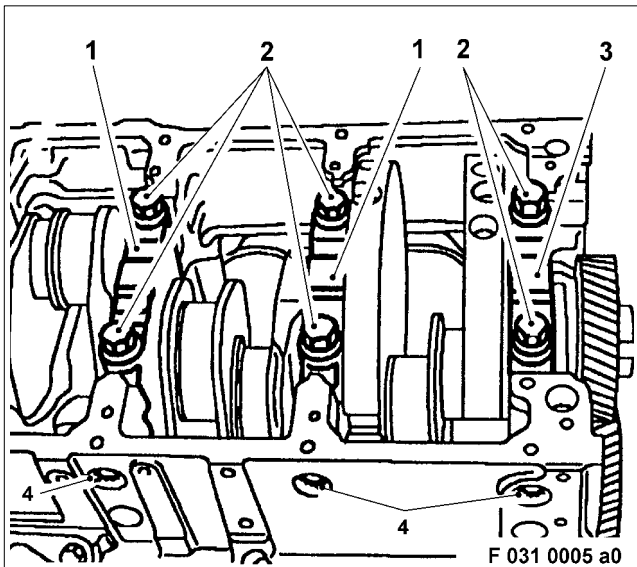

Spray crankshaft bearing journals with engine oil.

Note: Prior to installing bearing cap No. 1, ensure that counterweight is in lower position.

CAUTION

**Components have sharp edges.
Risk of injury!
Handle components only when wearing protective gloves.**

Insert crankshaft alignment bearing cap (3) and crankshaft bearing cap (1) in accordance with marking into crankcase.

Screw in and tighten central hex screws (2) in accordance with designation.

Coat thread and mating face of side double-hex screws (4) with engine oil and insert double-hex screws but do not tighten.

Starting at central screws of alignment bearing, pretighten to specified pretightening torque – see C 031.05.01.

Note: Always tighten screws on one bearing at same time.
Tightening sequence starts from alignment bearing.

Mark screw heads.

Tighten screws through specified angle of further rotation.

Tighten side double-hex screws to specified torque in same sequence as when tightening centre screws – see C 031.05.01.

Note: Tighten screws on one bearing at same time.

Bar crankshaft manually and check for ease of movement.

Crankshaft must turn freely.

C 037.05 Pistons and Conrods

C 037.05.01 Overview Drawing

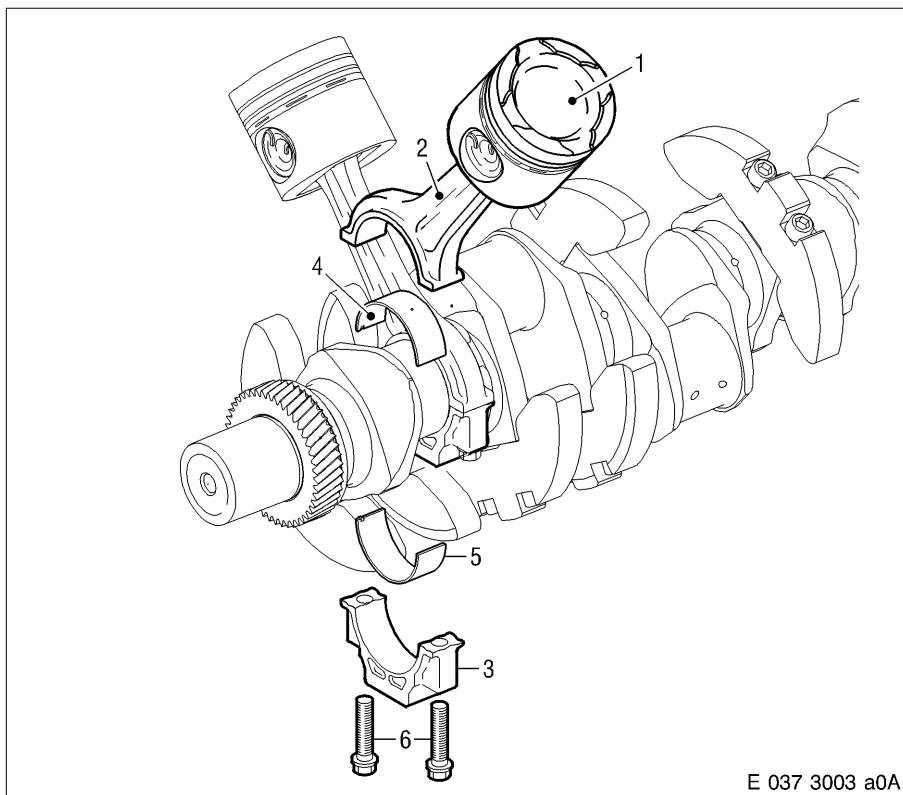

- 1 Piston
- 2 Conrod
- 3 Conrod cap
- 4 Conrod bearing, top
- 5 Conrod bearing, bottom
- 6 Conrod screw *

Max. shaft length:
 Conrod with cracked mating face: 74.5 mm
 Conrod with toothed mating face: 68.5 mm
 Lubricant: Engine oil
 Pretightening torque: 100 Nm + 10 Nm
 Angle of further rotation: 90° + 10°

* Replace conrod cap screws with cracked mating faces during each engine disassembly.

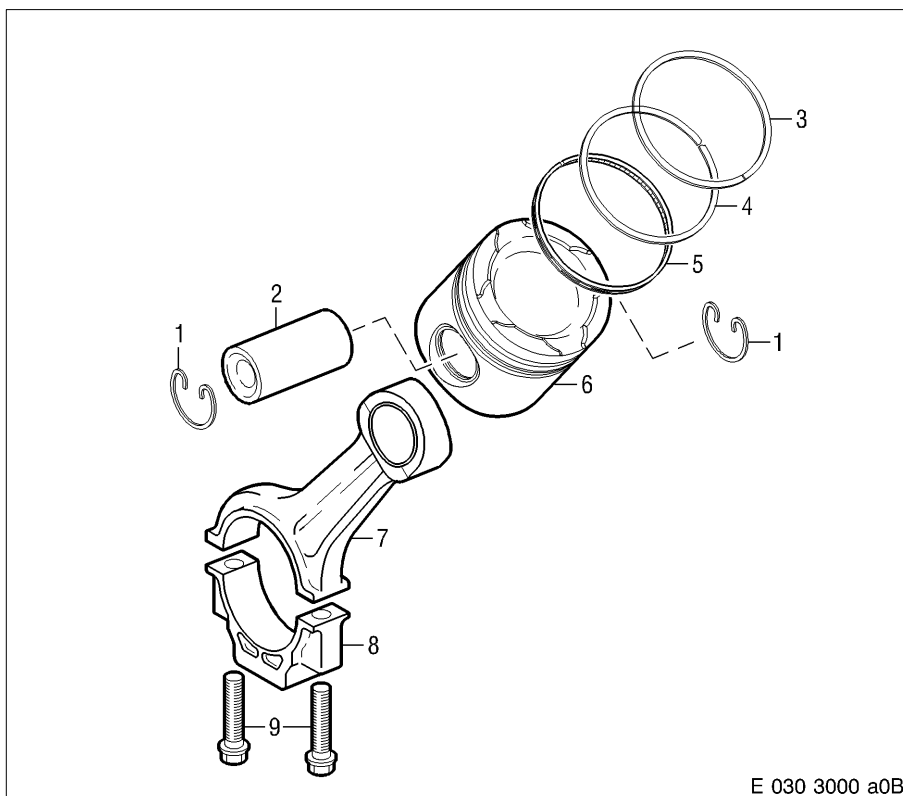

- 1 Snap ring
- 2 Piston pin
- 3 Keystone-type compression ring
- 4 Taper-face compression ring
- 5 Oil scraper ring
- 6 Piston
- 7 Conrod
- 8 Conrod cap
- 9 Conrod screw *

* **Only attach conrod bearing cover with bearing shell installed.**

C 037.05.02 Special Tool

Designation – Application	Number
Socket for conrod screws	1
Piston ring pliers	1
Barring tool for flywheel	1
Piston ring band clamp	1
Ring gauge for piston ring end clearance measuring	1
Installation tool for conrod bearings	1
Bridge meter for piston protrusion measuring	1

C 037.05.04 Before-Removal Operations

A distinction must be made as to whether:

- 1 ————— The engine is to be completely disassembled
- 2 ————— The engine is to be removed but not disassembled
- 3 ————— The engine is to remain installed

1	2	3	Operations	See
x	–	–	Remove engine	B 003
x	–	–	Perform operations as per Disassembly Plan	B 004
–	–	x	Disable engine start	Operating Instructions
–	–	x	Drain engine coolant	Operating Instructions
–	–	x	Drain or draw off engine oil	Operating Instructions
–	x	x	Remove air supply system before turbocharger (if necessary)	–
–	x	x	Remove crankcase ventilation (if necessary)	C 018.10
–	x	x	Disconnect or remove electrical cable (if necessary)	–
–	x	x	Release or remove charge air manifold	C 124.05
–	x	x	Remove exhaust turbocharger	C 101.01
–	x	x	Remove exhaust manifold	C 142.05
–	x	x	Remove cylinder head cover	C 055.10
–	x	x	Remove H.P. fuel line	C 073.05
–	x	x	Disconnect leak-off fuel lines	C 086.05
–	x	x	Remove rocker arm assembly	C 055.05
–	x	x	Remove pushrods	C 054.05
–	x	x	Remove cylinder head	C 041.05
–	x	x	Remove oil pan	C 014.05

Connecting rod

Note: Replace conrod cap screws with cracked mating faces during each engine disassembly.

Using magnetic crack-testing method with fluorescent magnetic powder, check conrod, conrod cap and conrod screws for cracks.

If cracks are detected, replace part.

Important: Only conrods of the same type must be installed on a crankpin (connecting rod with cracked mating face **or** connecting rod with toothed mating face). Consequently, connecting rod must be replaced in pairs.

Check conrod and conrod screw threads for ease of movement.

Polish out all traces of nicks in conrod; replace conrod if necessary.

Check conrod for blue colouring; if blue colouring is detected (due to bearing damage), replace connecting rod.

Check main bore for wear and scoring; replace conrod if necessary.

Check conrod bush for scoring, dirt, wear and hot runs; burnish minor scoring with emery cloth; replace conrod bush if necessary.



CAUTION

Compressed air is highly pressurized. Risk of injury!

If compressed air is used for blowing out or blow-drying components, always wear protective goggles or safety mask. Pressure must not exceed 3.0 bar.

Clean interfaces of conrod and conrod cap and blow dry with compressed air.

The cracked (broken) interfaces must not be damaged; replace connecting rod as necessary.

Use a brass brush to clean tothing on conrod and conrod cap mating faces and blow dry with compressed air.

Use oilstone to remove surface irregularities and traces of wear from serrations.

Apply engineer's blue to check contact pattern.

Check that lube oil bore in connecting rod is perfectly clean; if necessary clean with bristle brush and blow with compressed air.

Note: Never use a wire brush!

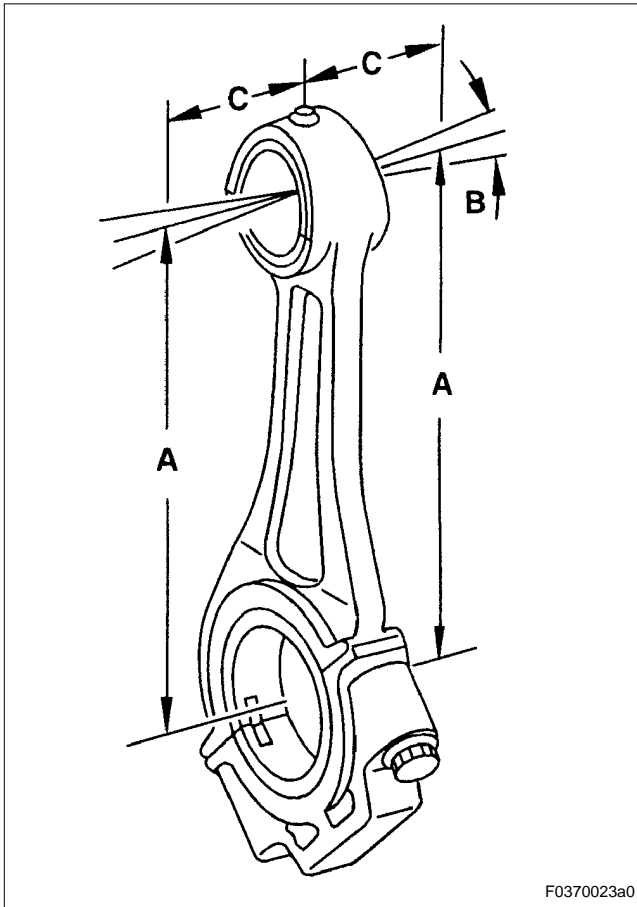

Checking conrod twist

Measure permitted deviation (B) of bend between conrod bearing and conrod bushing bore to measuring distance (C).

Measure distance (A) from centre conrod bearing bore to centre conrod bushing bore.

For required measurements and limit values – see Tolerance and Wear Limits List.

If limit values are exceeded, replace conrod.

Note: Connecting rod must not be straightened!

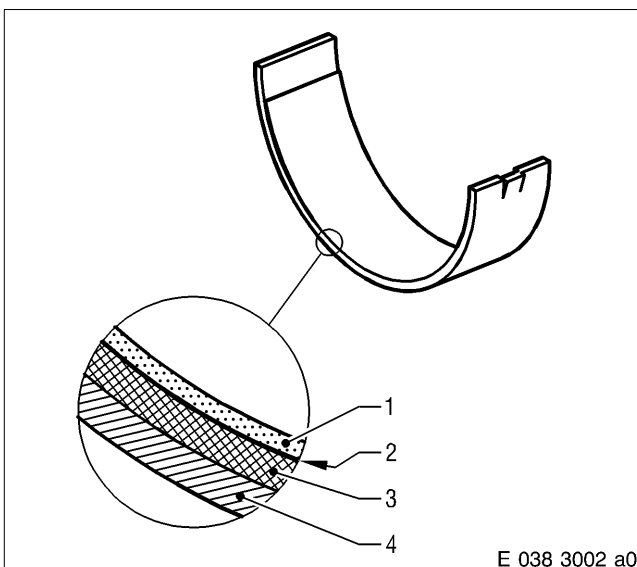

Checking and assessing conrod bearing shells

Check surface condition of bearing shells and check shells for wear. Replace worn or chipped bearing shells.

Replace bearing shells as part of every W6 overhaul.

Bearing shell has the following material structure:

- 1 Sliding layer (from 12 µm to 20 µm)
- 2 Intermediate layer (nickel barrier)
- 3 Bearing metal
- 4 Steel support shell

An important indicator for assessing extent of wear on bearing shell is the shape and extent of the nickel barrier areas exposed.

Use of bearing shell is reduced to 70% of sliding layer in friction area!

Note: It is often difficult to differentiate between the hard nickel barrier and softer sliding layer. If in doubt, consult a bearing specialist.

Check condition of bearing shell butt and bearing reverse side and check for friction corrosion (pitting); if there is evidence of friction corrosion, replace bearing shell and determine cause.

Possible causes: Screws not sufficiently pretensioned, assembly fault, bearing shell spread dimension is outside tolerance limit and defective bearing support bore.

Measure bearing shells spread dimension.

If spread dimension is too low (see Tolerance and Wear Limits List), replace bearing shells.

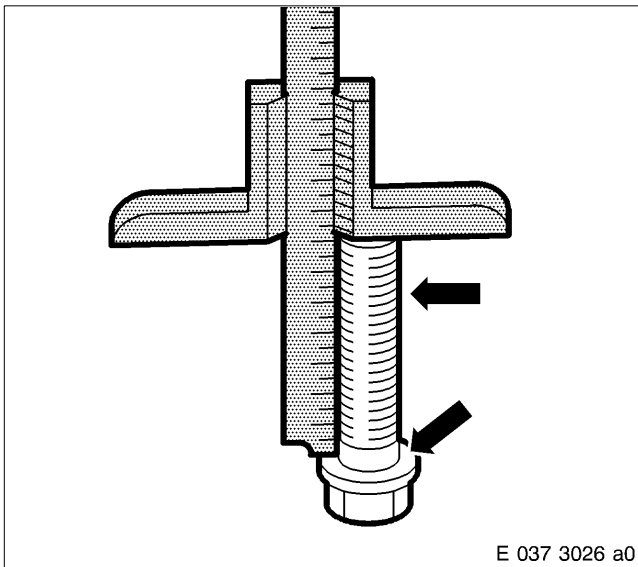

Checking conrod cap screw

Note: Replace conrod cap screws with cracked mating faces during each engine disassembly.

Check screw head support and thread (arrows) for scoring or damage; replace screw if necessary.

Measure shaft length of conrod screw with depth gauge.

For max. permissible shaft length – see C 037.05.01.

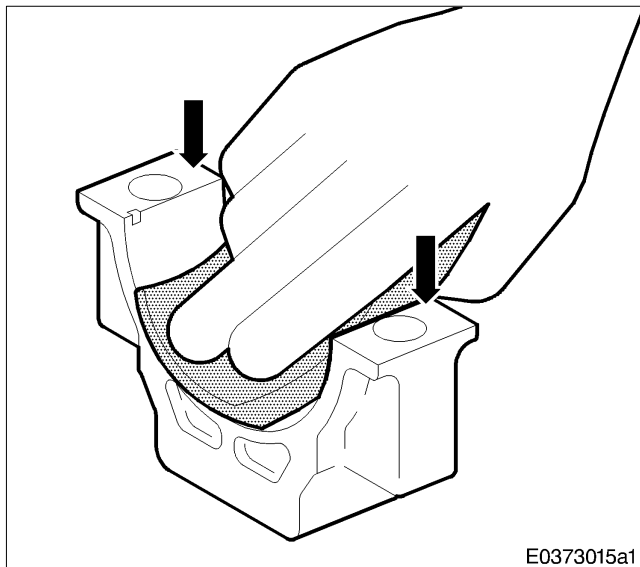

Storing conrod bearing shells

CAUTION

Compressed air is air which has been compressed under pressure. Risk of injury!
If compressed air is used for blowing out or blow-drying components, always wear protective goggles or safety mask.
Compressed air must not be directed at the body.
The pressure must not exceed 3.0 bar (40 lb/in²).

Blow out mating interfaces (arrows) on connecting rod and conrod cap with compressed air and check that they are clean.

Important: The cracked (broken) interfaces must not be damaged; replace connecting rod as necessary.

Wipe bearing shell mating faces on connecting rod and conrod cap.

Note: New conrod bearing shells must be installed as part of every W6 overhaul.
Prior to installing conrod bearing shells, compare repair stage marking on connecting rod and in crankshaft data sheet.

Mark conrod bearing shells according to cylinder number on front face.

Note: Top and bottom bearing shells have different part numbers.

Wipe lower conrod bearing shell (shell without oil bore) on both sides with chamois leather and install into conrod bearing cover.

Securing lug (arrow) of conrod bearing shell must sit in groove in conrod bearing cover.

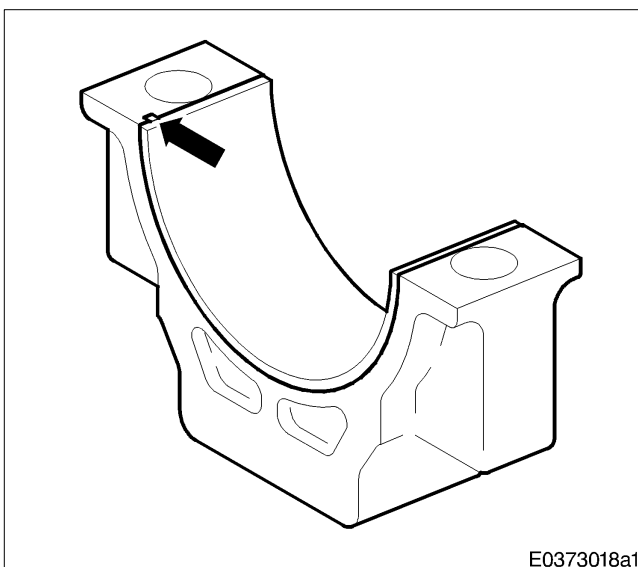

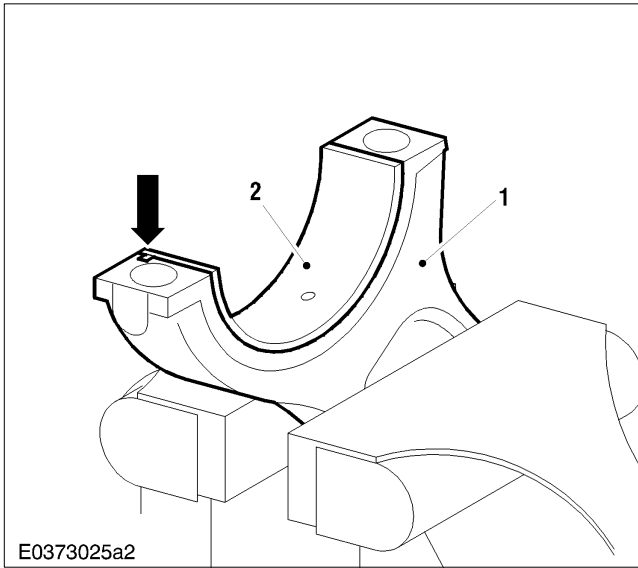

Clamp conrod (1) in vice with aluminium jaws.
Wipe upper conrod bearing shell (2) (shell with oil bore) on both sides with chamois leather and fit into conrod.
Securing lug (arrow) of conrod bearing shell must sit in the groove of the connecting rod and the bore in the conrod bearing shell and conrod must match.
For conrod with toothed partition, align conrod bearing shell with assembly device – see Section C 037.05.11.

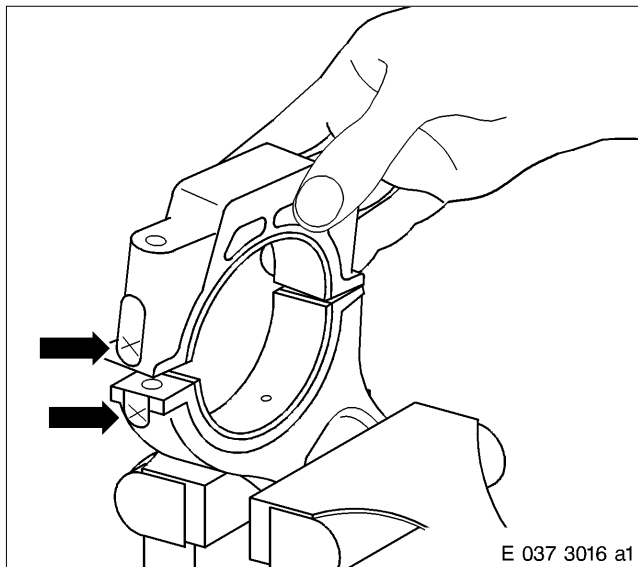

Place conrod cap in position on conrod, making sure that serial numbers (arrows) match.
Coat threads of screw head mating face and screw head seating surfaces with engine oil.
Fit conrod cap screws.
Note: Manually press conrod cap into place when installing conrod screws.

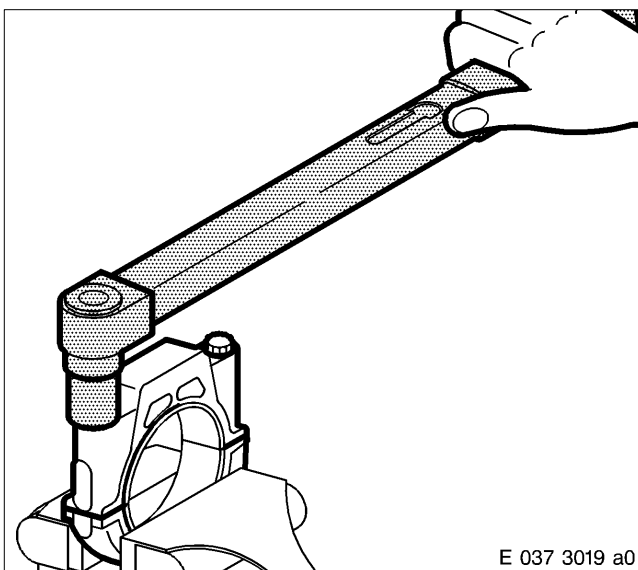

To avoid twisting the conrod, clamp conrod in vice according to diagram.
Pretighten conrod screws with torque wrench and socket to specified pretightening torque – see C 037.05.01.
Mark screw heads.
Tighten conrod screws through specified additional angle of rotation.

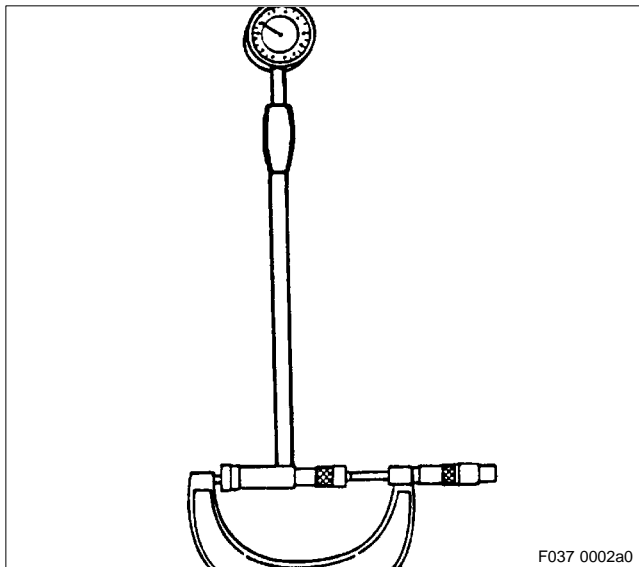

Adjust bore gauge and dial gauge with micrometer to basic size for conrod bearing bore as per Tolerance and Wear Limits List.

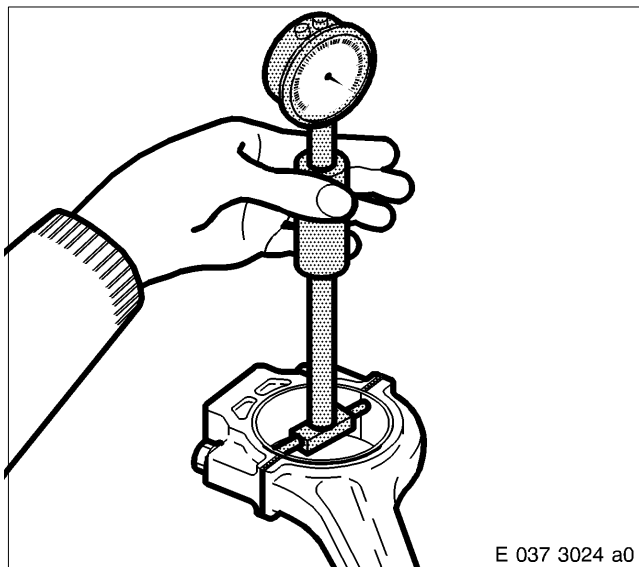

Coat sliding surfaces of bearing shells with engine oil.
Measure conrod bearing bore of conrod.
For limit values and measuring planes – see Tolerance and Wear Limits List.
Enter measurement values in data sheet.
If limits values are exceeded or not achieved, replace bearing shells or machine conrod basic bore to repair size.

Note: Conrod bearing shells are ready for installation when supplied. No reconditioning must be carried out.

Remove conrod screws, conrod cap and bearing shells.
Protect bearing shells from damage!

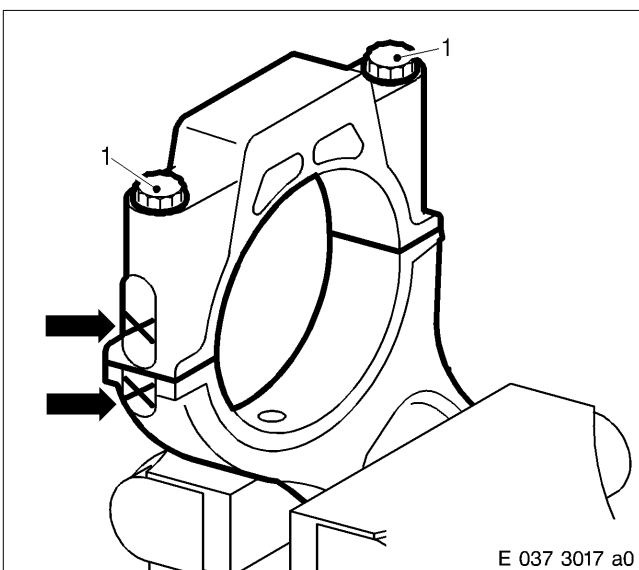

Measuring conrod basic bore

Note: Never secure conrod cover to conrod if bearing shells are not installed; just place in position.

Correctly fit conrod cap on connecting rod.
Check that markings (arrows) for conrod cap to conrod are aligned.

Manually press conrod cap into place, insert conrod screw (1) and tighten (10 to 20 Nm).

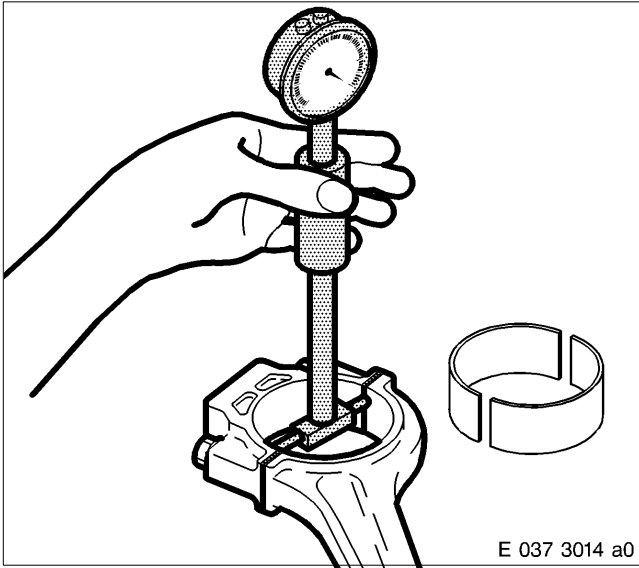

Adjust bore gauge to basic size conrod bearing bore and measure.

For basic size of conrod basic bore, limit values and measuring points – see Tolerance and Wear Limits List.

If limit values are exceeded, machine conrod main bore to repair size or replace conrod.

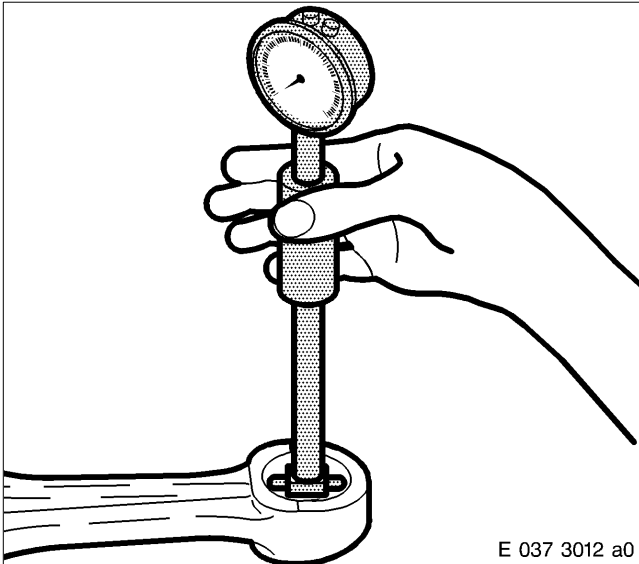

Measuring conrod bushing bore

Adjust bore gauge to zero dimension for conrod bush bore as per Tolerance and Wear Limits List and measure bore of conrod bush.

If limit values are exceeded, replace conrod bush.

It is imperative to contact MTU and/or DDC.

C 037.05.10 Assembly

Note: Always make sure that all components are perfectly clean.

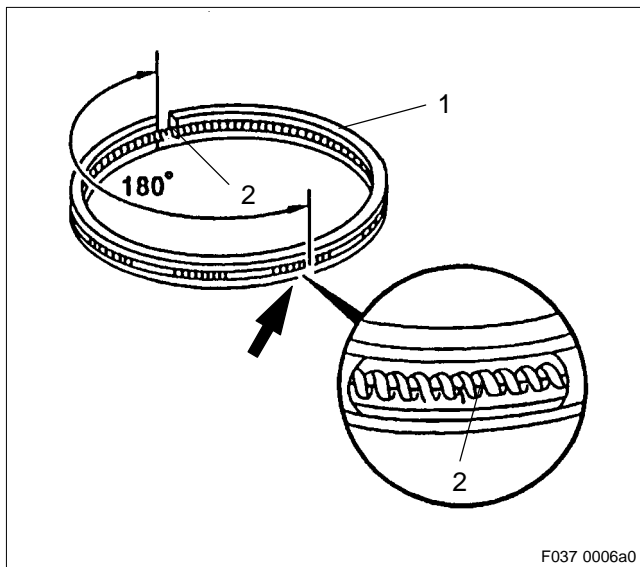

F037 0006a0

Installing piston rings

Turn coiled spring expander (2) in oil scraper ring (1) to offset ring spring butting face (arrow) to oil scraper ring butt by 180°.

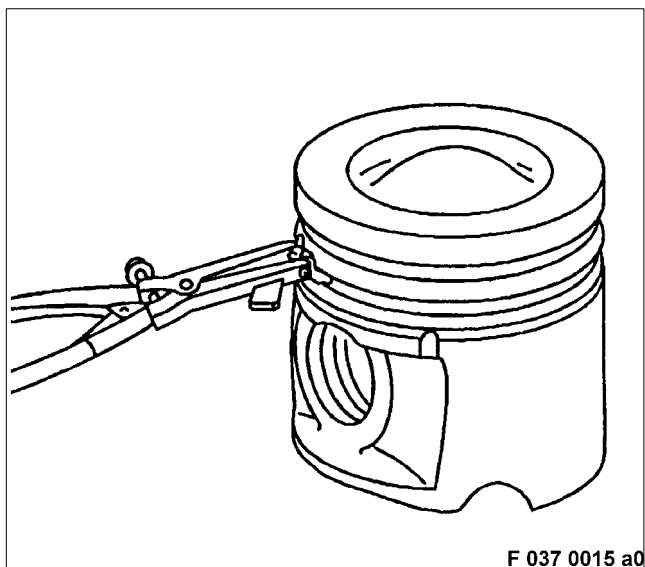

F 037 0015 a0

In sequence from bottom to top (oil scraper ring first), insert piston rings with piston ring pliers into annular grooves on piston.

Important: Stretch piston rings (arrows) only until they can be fitted over the piston. Do not overstretch piston rings, as **they may break**.

Make sure piston rings are installed in correct sequence – see next illustration.

TOP marking on piston rings must point upwards.

Note: Oil scraper ring does not have a TOP marking, installation position as required.

Check that piston rings move freely in their grooves.

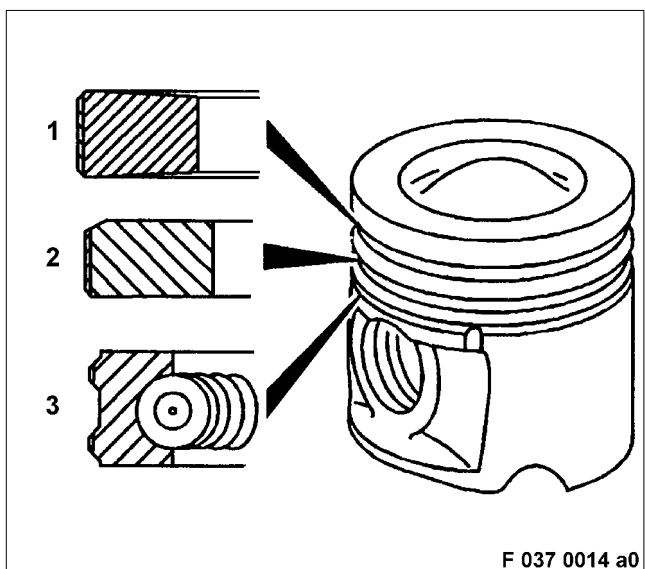

F 037 0014 a0

Sequence of piston rings:

- 1 – Keystone-type compression ring
- 2 – Taper-face compression ring
- 3 – Oil scraper ring

Note: Piston rings must only be replaced in sets. Hone cylinder liners if new piston rings are installed.

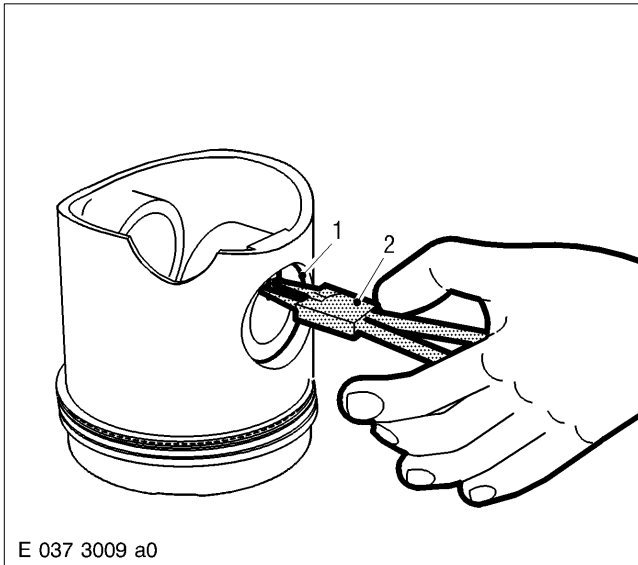

Installing conrod in piston

CAUTION

**Snap ring pretension.
Risk of injury!
Use suitable circlip pliers. Always wear protective goggles/safety mask.**

Using circlip pliers (2), insert snap ring (1) into piston boss.

Note: Make sure snap ring is perfectly seated in groove. Snap ring must be seated securely in the groove.

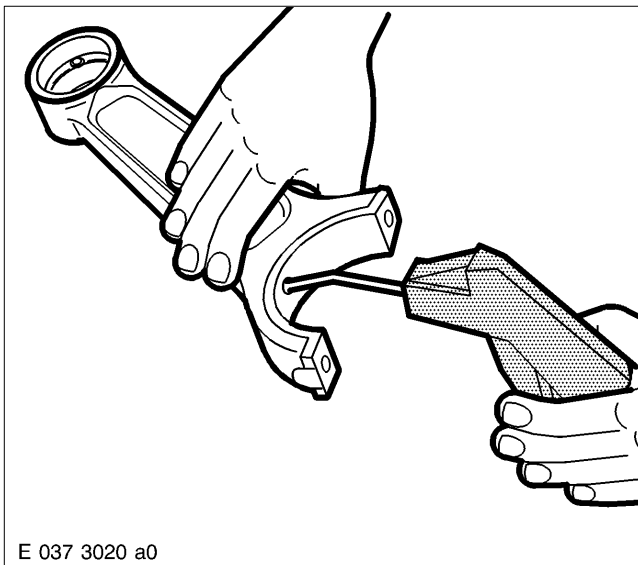

CAUTION

**Compressed air is air which has been compressed under pressure. Risk of injury!
If compressed air is used for blowing out or blow-drying components, always wear protective goggles or safety mask.
Compressed air must not be directed at the body.
The pressure must not exceed 3.0 bar (40 lb/in²).**

Blow through lube oil bores in conrod with compressed air and ensure that they are perfectly clean.

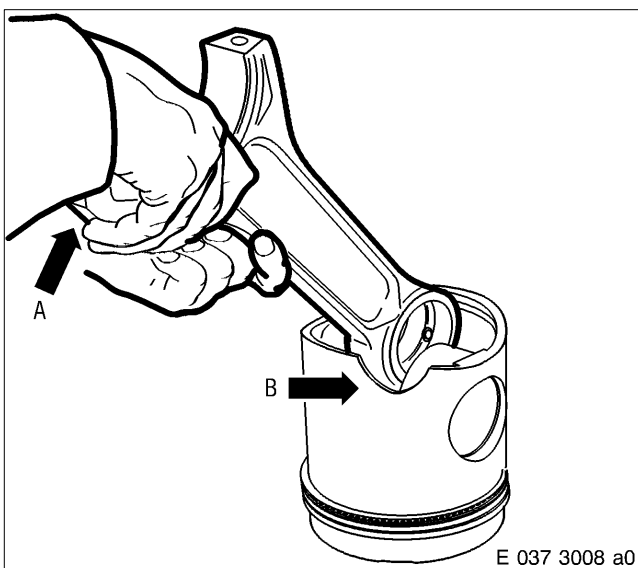

Wipe down piston pin, conrod bushing and piston pin bore with chamois leather and coat with engine oil. Insert conrod according to markings into relevant piston in such a way that the longer end (A) of the angle-split conrod faces recess (B) for oil spray nozzle.

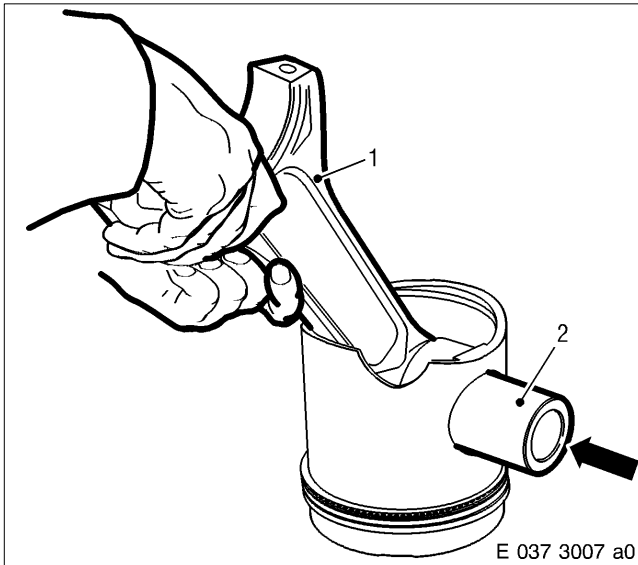

Push associated piston pin (2) into piston and conrod (1) until seated against snap ring installed beforehand (arrow).

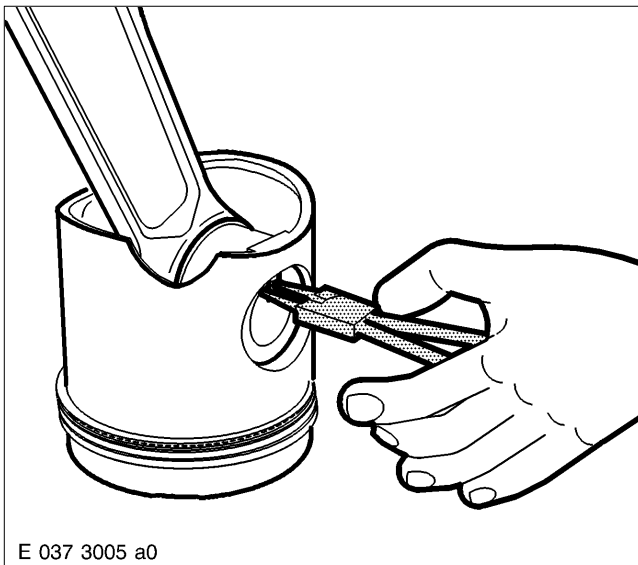

⚠ CAUTION

**Snap ring pretension.
Risk of injury!
Use suitable circlip pliers. Always wear protective goggles/safety mask.**

Insert second snap ring with circlip pliers.

Note: Make sure snap ring is perfectly seated in groove. Snap ring must be seated securely in the groove.

C 037.05.11 Installation

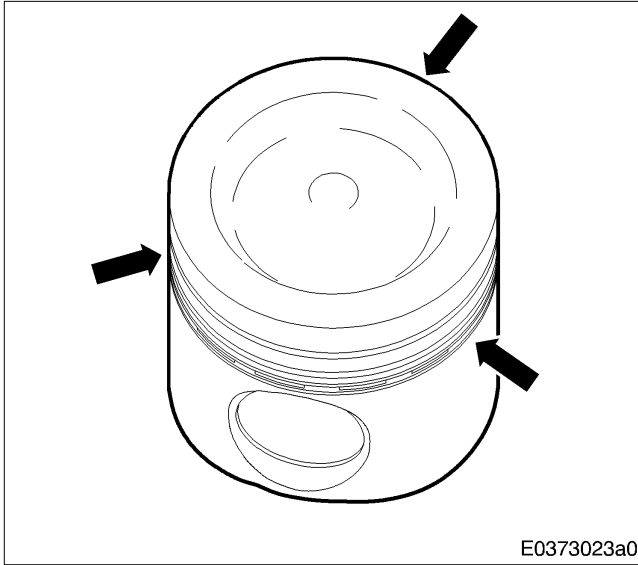

Installing piston with conrod in assembly dolly

Note: Always make sure that all components are perfectly clean.

Spray the piston and piston rings with engine oil. Position piston ring butts (arrows) consecutively at 120° intervals.

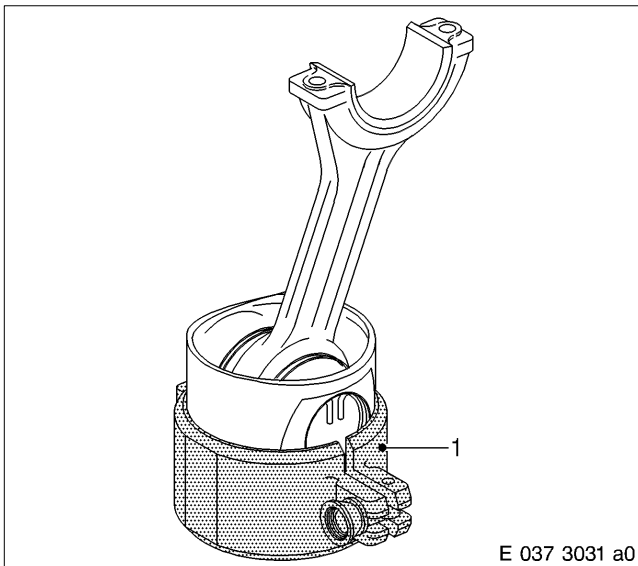

Install piston ring band clamp (1) over the piston rings as shown in the illustration.

Note: Check radial mobility of piston ring band clamp. The band clamp must turn easily; if this is not the case, remove it and check the piston rings.

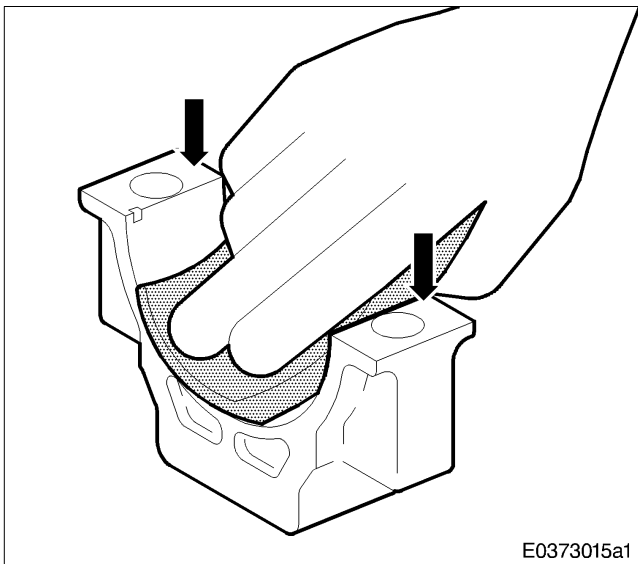

CAUTION

Compressed air is air which has been compressed under pressure. Risk of injury!
If compressed air is used for blowing out or blow-drying components, always wear protective goggles or safety mask.
Compressed air must not be directed at the body.
The pressure must not exceed 3.0 bar (40 lb/in²).

Blow out interfaces (arrows) on connecting rod and conrod cap with compressed air and check that they are clean.

Important: The cracked (broken) interfaces must not be damaged; replace connecting rod as necessary.

Wipe bearing shell mating faces on connecting rod and conrod cap.

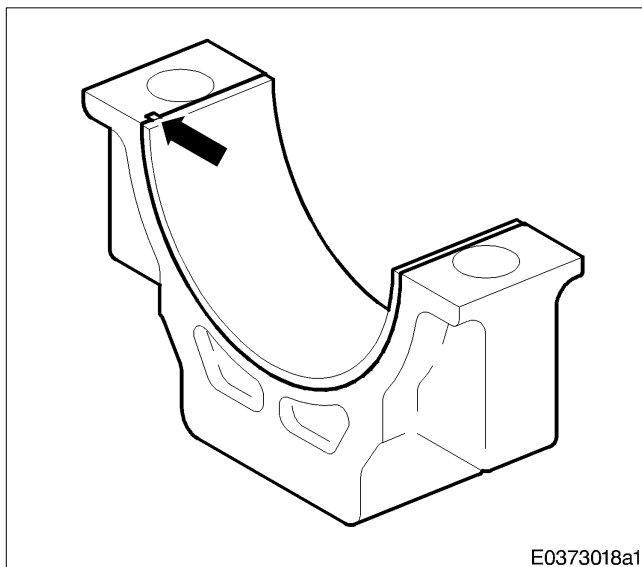

E0373018a1

Note: Prior to installing bearing shell, note respective stage on connecting rod and crankshaft journal – see data sheets.
Top and bottom bearing shells have different part numbers.

Wipe lower conrod bearing shell (shell without oil bore) on both sides with chamois leather and fit into conrod cover in accordance with their markings.

Securing lug (arrow) of conrod bearing shell must sit in groove in conrod cap.

Coat friction face of conrod bearing shell with engine oil.

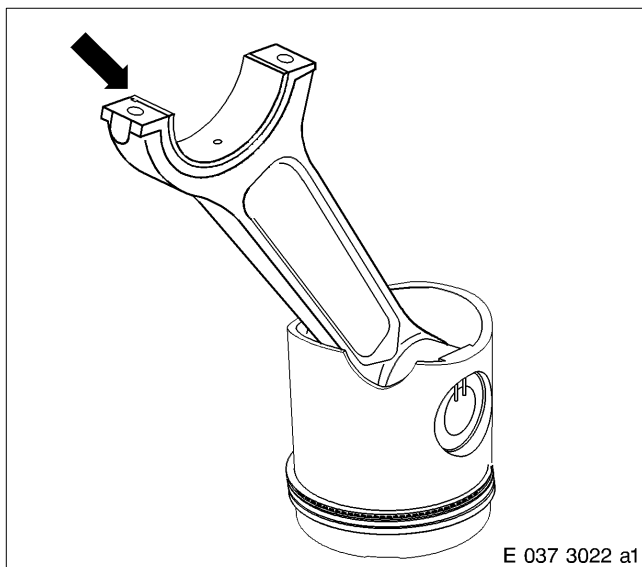

E 037 3022 a1

Wipe upper conrod bearing shell (shell with oil bore) on both sides with chamois leather and fit into conrod in accordance with their markings.

Securing lug (arrow) of conrod bearing shell must sit in groove in conrod.

Bore in the conrod bearing shell and conrod must be aligned.

Coat friction face of conrod bearing shell with engine oil.

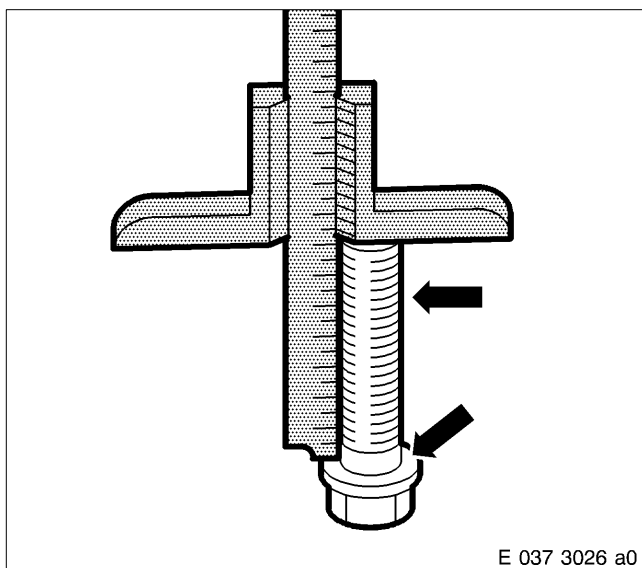

E 037 3026 a0

Measure shaft length of conrod screws; for max. shaft length – see C 037.05.01.

Coat threads and screw head seating surfaces (arrows) with engine oil.

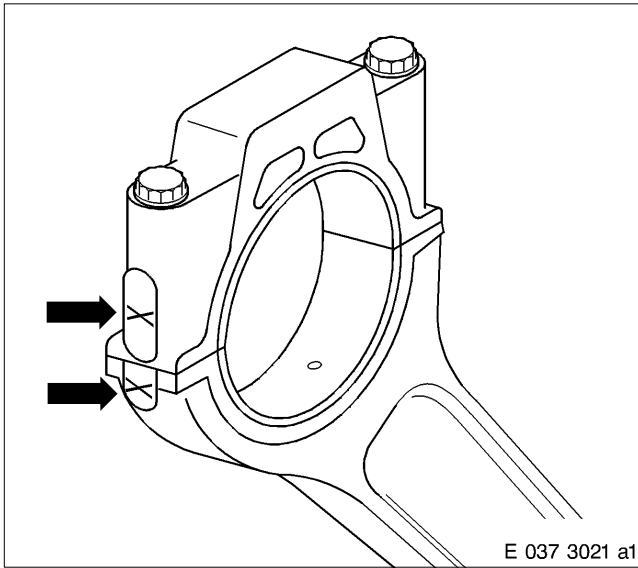

Check that markings (arrows) for conrod cap to conrod are aligned.

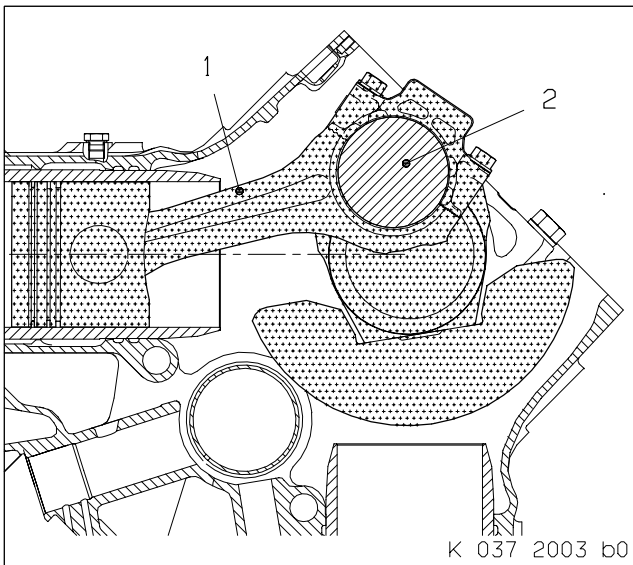

Important: Only conrods of the same type must be installed on a crankpin (connecting rod with cracked mating face **or** connecting rod with toothed mating face).

Rotate crankcase in assembly dolly until cylinder liners are horizontal.

Turn crankpin (2) of crankshaft of piston to be installed with connecting rod (1) according to sketch to assembly position.

Wipe crankpin and running surface of cylinder liner and spray with engine oil.

Insert piston according to markings in associated cylinder liner until the piston ring band clamp is in contact with the cylinder liner.

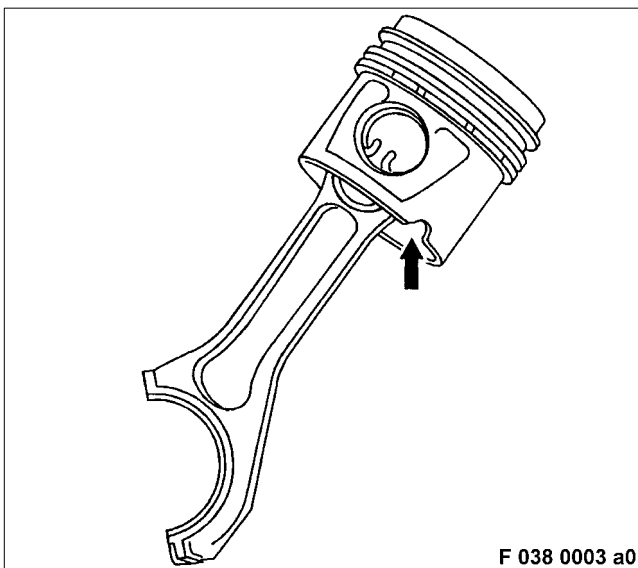

The recess (arrow) for the oil spray nozzle on the piston points inwards to the engine centre.

Note: In order to guide the conrod and avoid damage to the oil spray nozzle, piston installation must be carried out by two people.

Gently turn piston when inserting so that the oil spray nozzle is not damaged when the conrod is installed.

If the oil spray nozzle is damaged, remove spray nozzle and replace.

Press in piston until the conrod bearing shell fits exactly on crankpin of crankshaft, turn crankshaft if necessary.

Remove piston ring band clamp.

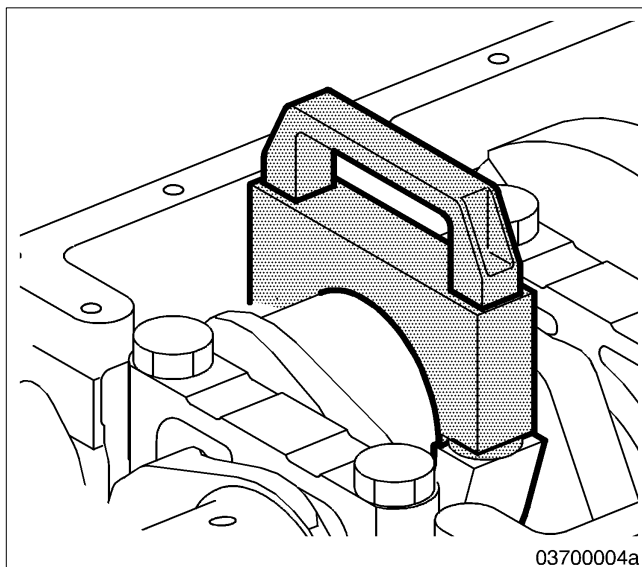

Note: With connecting rod with toothed partition, bearing shell must be aligned with the assembly device.

Align conrod bearing shell with assembly device, holding piston and connecting rod firmly in position to prevent displacement of conrod.

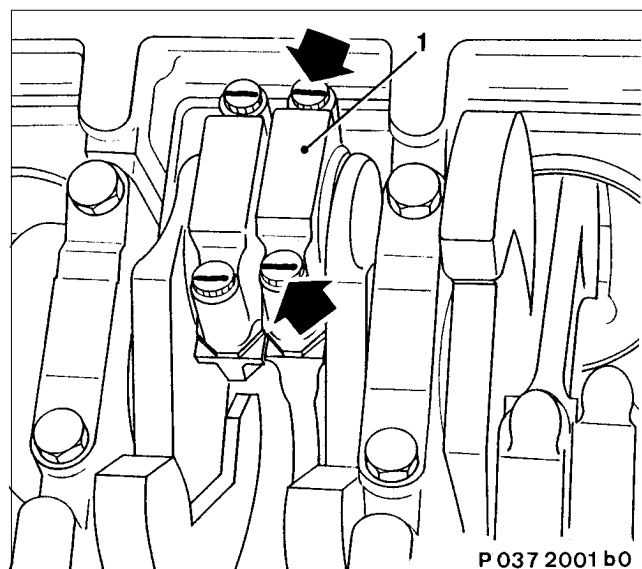

Fit conrod cap (1) correctly (marking must be on one side) and manually insert conrod screws.

Note: Manually press conrod cap into place when installing conrod screws.

Pretighten conrod screws with torque wrench and socket to specified pretightening torque – see C 037.05.01.

Check that conrod has axial play.

If there is no axial clearance, remove conrod cap and replace damaged bearing shell.

Mark screw heads (arrows).

Tighten conrod screws through specified additional angle of rotation.

Check that conrod has axial play.

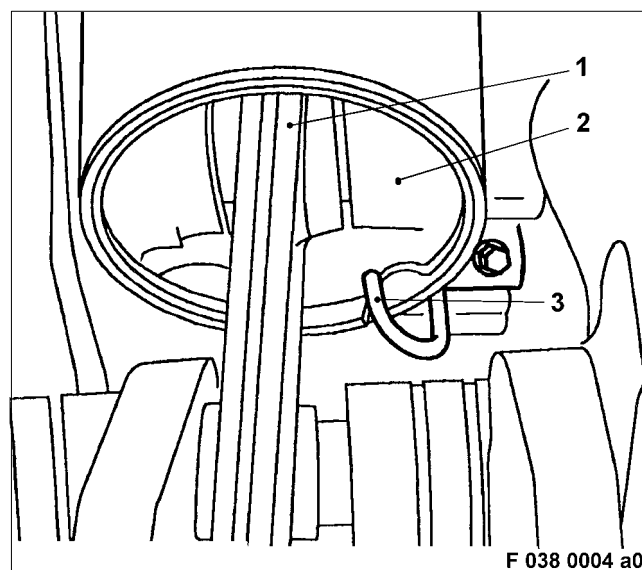

Bar crankshaft and ensure that there is ease of movement between oil spray nozzle (3), piston (2) and conrod (1).

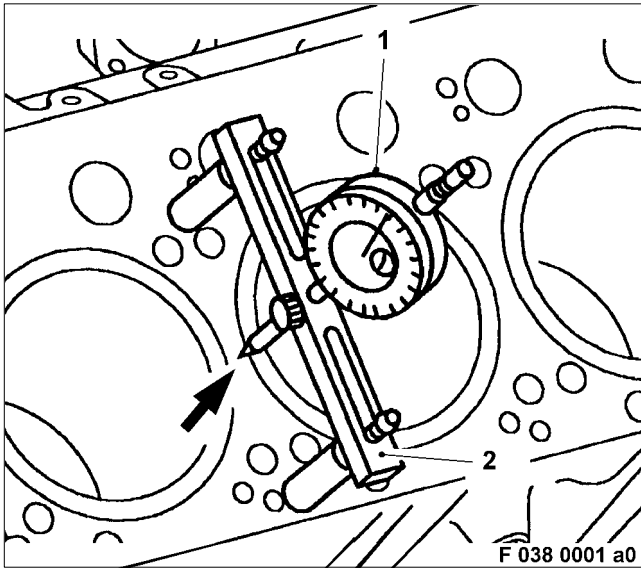

Measuring piston protrusion

Note: Measure protrusion between piston crown and crankcase partition without the cylinder head gasket in position.
To eliminate piston-tilt clearance, perform measurements in direction of piston pin.

Clean residues from piston and crankcase partition.
Turn the crankshaft slowly in engine direction of rotation until the piston being measured is approx. 1 cm before TDC.

Secure dial gauge (1) with pretension in the bridge meter (2).

Position bridge meter and dial gauge stylus (arrow) on crankcase partition and set dial gauge scale to zero.

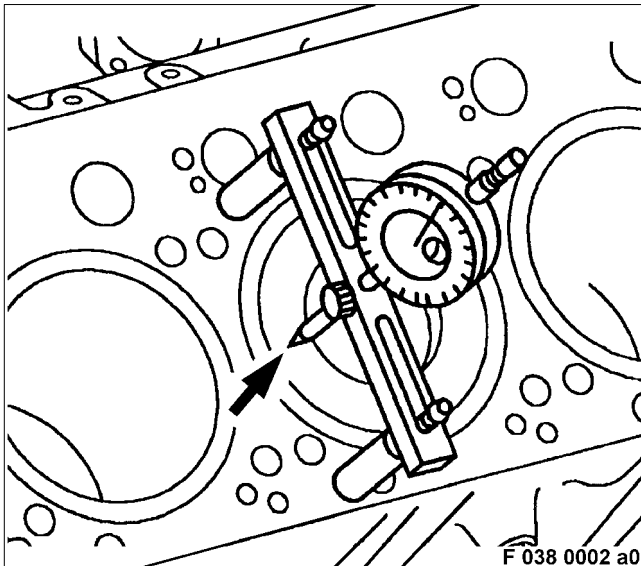

Move bridge meter and feeler from the crankcase partition over the outer piston face (arrow); hold back the dial gauge stylus while doing this.

Turn the crankshaft slowly in engine direction of rotation until the dial gauge pointer no longer moves or the piston is precisely at TDC.

Read off and make a note of piston protrusion at dial gauge.

Measure piston protrusion of all pistons in the same way.

For specified values, see Tolerance and Wear Limits List.

If the tolerance deviation is impermissible, check the affected conrod and replace if necessary.

C 037.05.12 After-Installation Operations

A distinction must be made as to whether:

- 1 ————— The engine was completely disassembled
- 2 ————— The engine is removed but was not disassembled
- 3 ————— The engine is installed

1	2	3	Operations	See
x	-	-	Perform operations as per Assembly Plan	B 005
x	-	-	Install engine	B 007
-	x	x	Install oil pan	C 014.05
-	x	x	Install cylinder head	C 041.05
-	x	x	Install pushrods	C 054.05
-	x	x	Install rocker arm assembly	C 055.05
-	x	x	Adjust valve clearance	C 055.05.11
-	x	x	Connect leak-off fuel lines	C 086.05
-	x	x	Install H.P. fuel line	C 073.05
-	x	x	Install cylinder head cover	C 055.10
-	x	x	Install exhaust manifold	C 142.05
-	x	x	Install turbocharger	C 101.01
-	x	x	Install charge air manifold	C 124.05
-	x	x	Connect electric cables	-
-	x	x	Install crankcase breather	C 018.10
-	x	x	Install air system before exhaust turbocharger	-
-	-	x	Fill oil system with engine oil	Operating Instructions
-	-	x	Fill engine coolant system	Operating Instructions
-	-	x	Release engine start	Operating Instructions



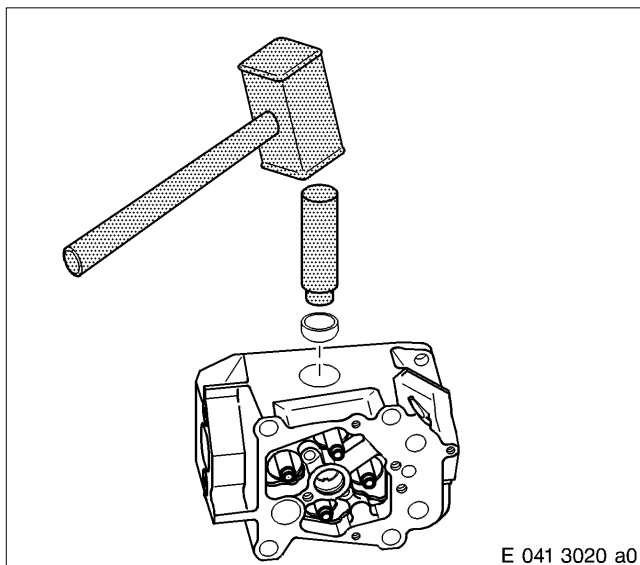

Replacing end cover

Note: Remove end cover only if necessary (e.g. in event of leakages).

Use a boring mill to remove end cover.

After completion of work, clean coolant chambers with cleaning agent.

CAUTION

**Compressed air is highly pressurized.
Risk of injury!**
If compressed air is used for blowing out or blow-drying components, always wear protective goggles or safety mask.
Compressed air must not be directed at the body.
Pressure must not exceed 3.0 bar.

Blow out coolant chambers with compressed air and check for cleanness.

Note: Metal shavings in the cylinder head coolant chamber may lead to local overheating.

Clean and degrease seating face on new end cover and cylinder head bore.

Coat seating face of cylinder head bore with thread-locking agent.

Using a mandrel, insert end cover flush with bore in cylinder head.

Note: Final strength of thread-locking agent at 20 °C ≈ 12 h!

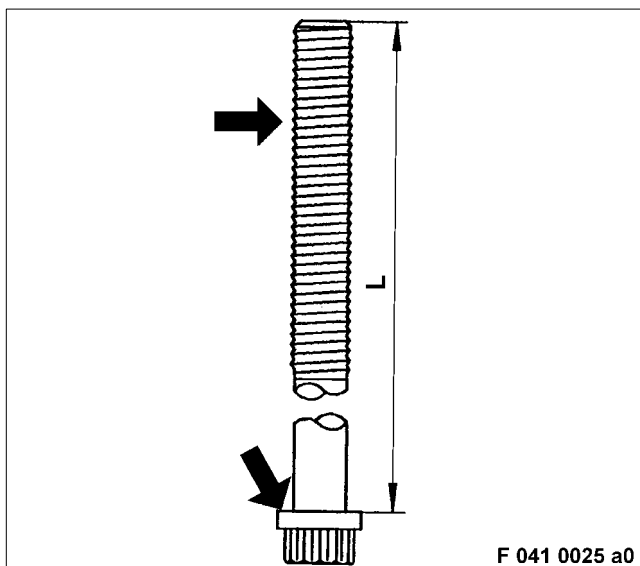

Checking cylinder head screws

Check screw head support and thread (arrows) for scoring or damage; replace screw if necessary.

Measure shaft length with depth gauge.

For max. permissible shaft length – see C 041.05.01.

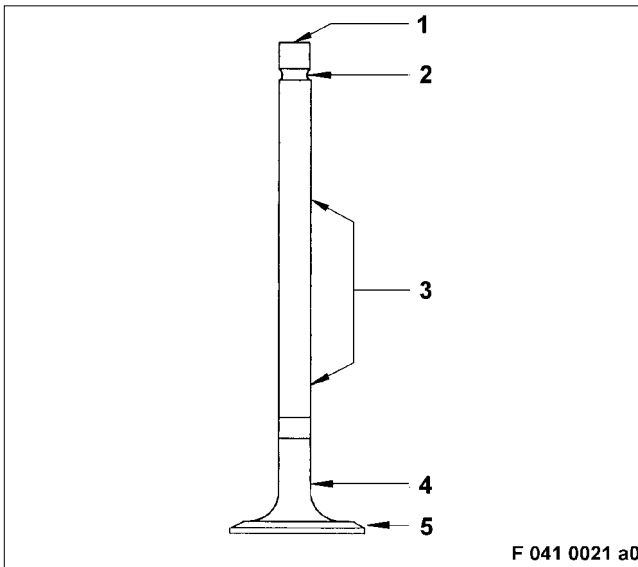

Checking valves

Check valves for damage, pitting, scoring and indentations on pressure surface (1), valve keyway (2), shaft (3) neck (4) and plate (5).

If chrome plating is damaged or worn through, if indentations or scoring are found on valve stem or pitting at transition from valve head to valve stem, replace valves.

Valve keyways must not be damaged and valve seats must not be burnt.

Check valves for concentricity and dimensional accuracy.

Regrind valve seat on a valve grinding machine to compensate minor deviations in the concentricity or replace valve.

Note: Do not straighten valves!

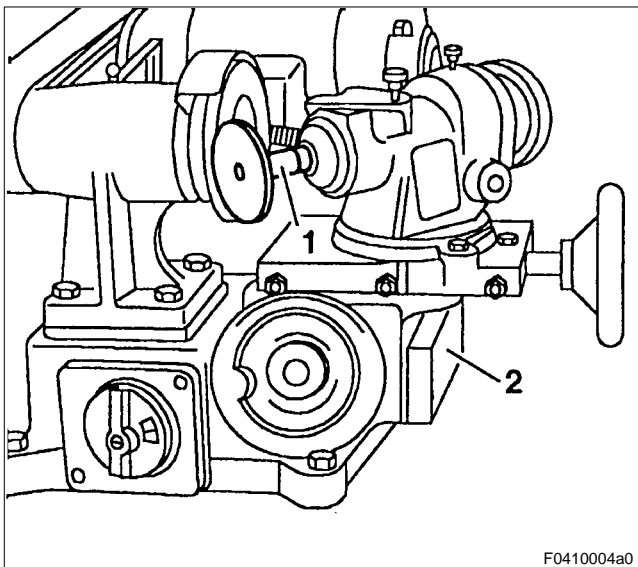

Regrinding valve seats

Note: Do not remove more material than is absolutely necessary to achieve perfect valve seating.

Clamp valve (1) in valve grinding machine (2) as close as possible behind the valve head (to prevent vibrations).

Set valve seat grinding angle on valve seat grinding machine.

Grind valve seat with slight advance until valve seat is smooth and free from chatter marks over the entire circumference.

Measure valve seat width.

If limit values as per Tolerance and Wear Limits List are exceeded, replace valve.

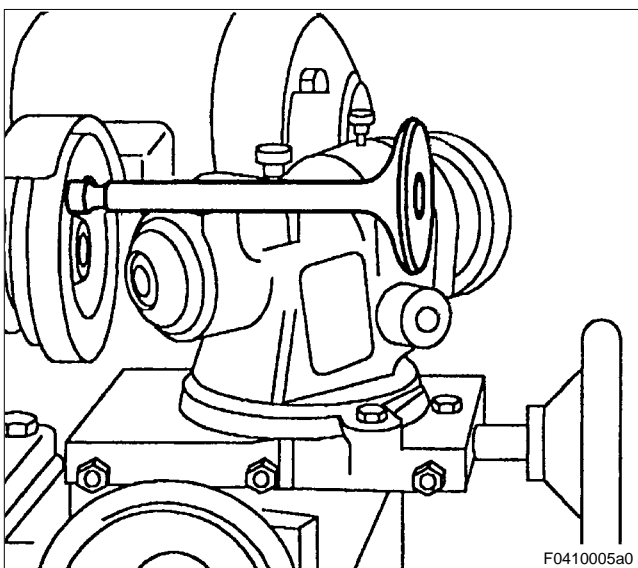

If necessary, recondition valve shaft end on device provided on valve grinding machine.

Measure valve length; if limit value is not achieved, (see Tolerance and Wear Limits List), replace components as necessary.

Using the surface crack-testing method with fluorescent penetrant dye, check valves for cracks; replace if necessary.

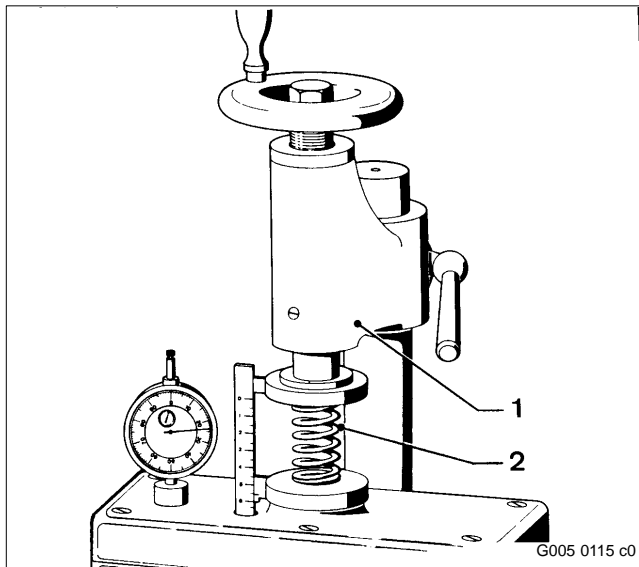

Checking valve springs

Check valve spring (2) with valve spring tester (1).
If limit values as per Tolerance and Wear Limits List are exceeded, replace valve spring.
Check valve springs for indentations, flatness, burring and deformation and replace if necessary.

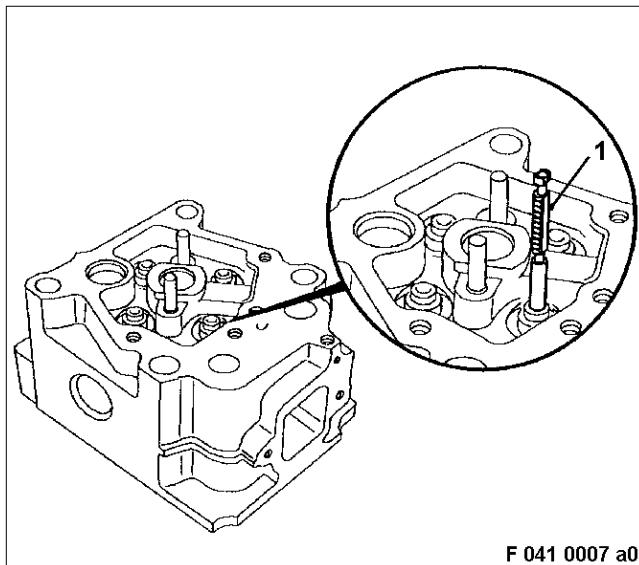

Checking valve guides

Clean bores of valve guides with valve guide cleaning brush.
Check all valve guides for wear and damage; replace components as necessary.
Check valve guides with plug gauge (1) for wear.
If side of plug gauge marked with “+” is able to pass through valve guide, replace valve guide.

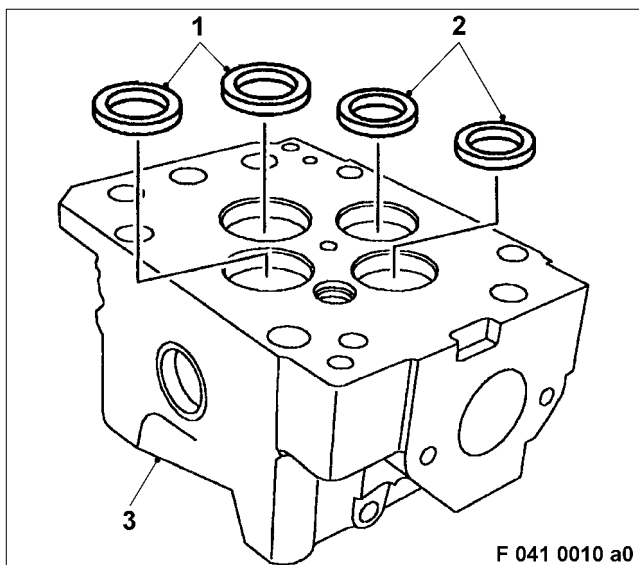

Checking valve seat inserts

Check valve seat insert – outlet (1) and valve seat insert – inlet (2) for cracks and visually check condition; replace valve seat inserts as required.

Recondition seats

- after extended periods of operation
- if findings are negative, e.g. damaged seat surfaces, deep pitting, uneven valve seat/valve taper bedding pattern.
- after installation of new valve seat inserts

Replace seats if

- there are cracks in the seat surface
- if areas are burnt through
- the reconditioning wear limit has been exceeded

Checking cylinder head for leaks

Carefully clean cylinder head after machining.

Note: The protective sleeve must be installed in order to test the coolant chambers for leaks.



WARNING

Compressed air is air which has been compressed under pressure. Risk of injury! Test pressure must not be exceeded. Always wear protective clothing, protective gloves and protective goggles/safety mask.

Pressure-test cylinder head with air in water bath for leaks.

Note: The water for pressure testing must be treated with anti-corrosive agent.

Coolant chamber: 2 bar air overpressure, permissible leak rate 10 cm³/min.

Fuel chamber: 2 bar air overpressure, permissible leak rate 3 cm³/min.

Air chambers (inlet and outlet ducts) and oil chambers are not inspected.

C 041.05.10 Assembly

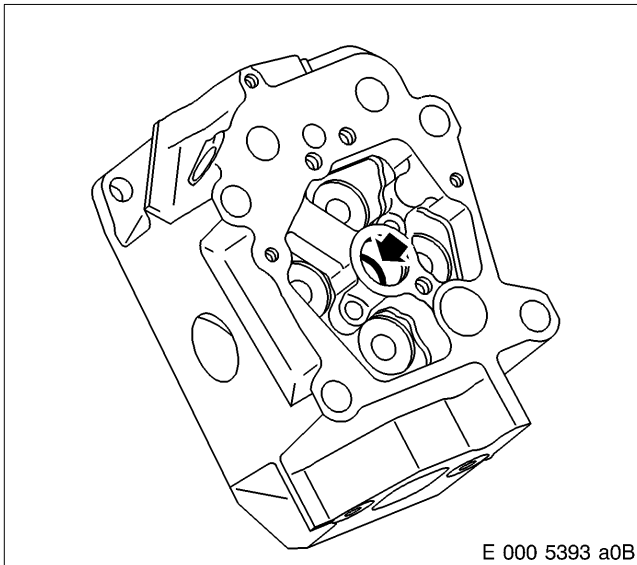

Installing protective sleeves

Clamp cylinder head in jig.

Check sealing face for protective sleeve and groove (arrow) for O-ring, clean if necessary.

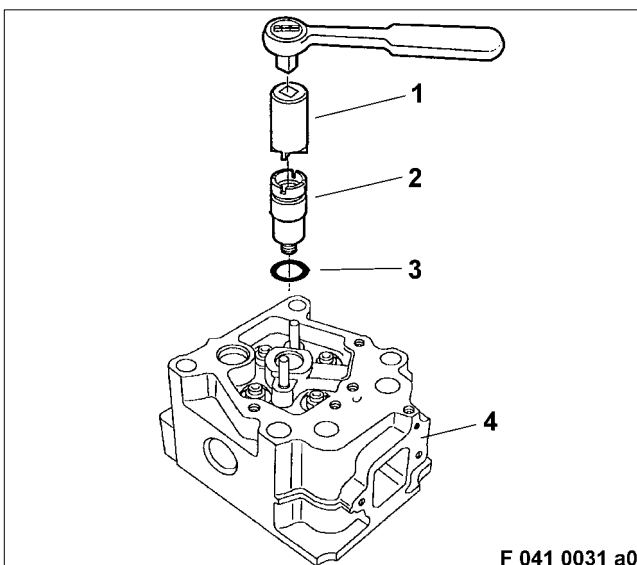

Check sealing surfaces on protective sleeve (2); clean if necessary.

Coat the new O-ring (3) with petroleum jelly and insert into groove in cylinder head (4).

Using socket (1), insert protective sleeve into cylinder head and tighten to specified tightening torque – see C 041.05.01.

Note: Make sure that socket is correctly engaged in sleeve groove.

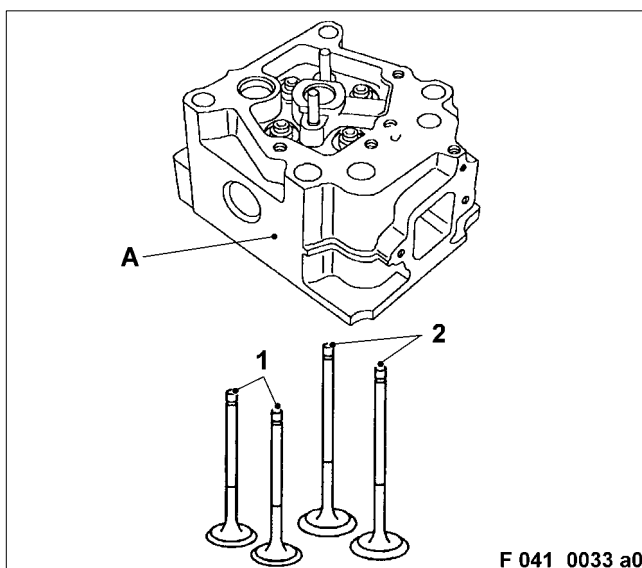

Installing valves, valves shaft gaskets and valve springs

Note: Make sure parts are perfectly clean.

Lay cylinder head on its side (A).

Wipe down exhaust valves (1) and inlet valves (2) with chamois leather and coat valve shafts with engine oil.

Insert valves in the corresponding valve guides in accordance with markings made prior to removal.

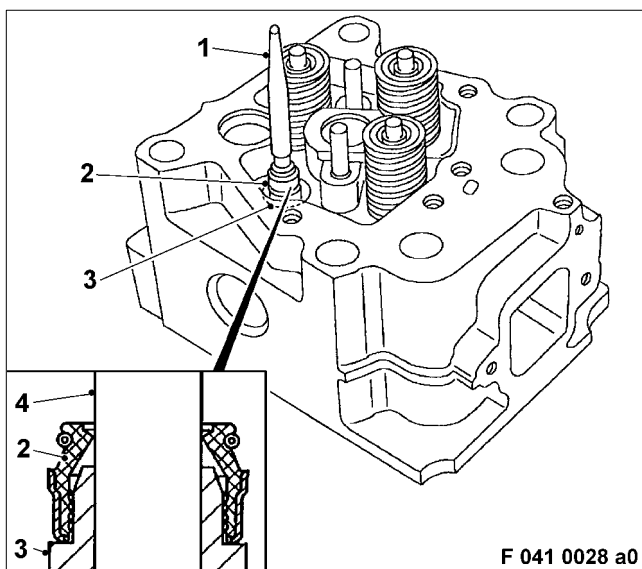

Fit cylinder head on cylinder head interface.

Fit sleeve (1) over valve stem (4).

Using a mandrel, manually press new valve stem gasket (2) over the sleeve onto the valve guide (3) to the stop.

Check that valve stem gasket is fitted securely in valve guide collar.

Remove sleeve.

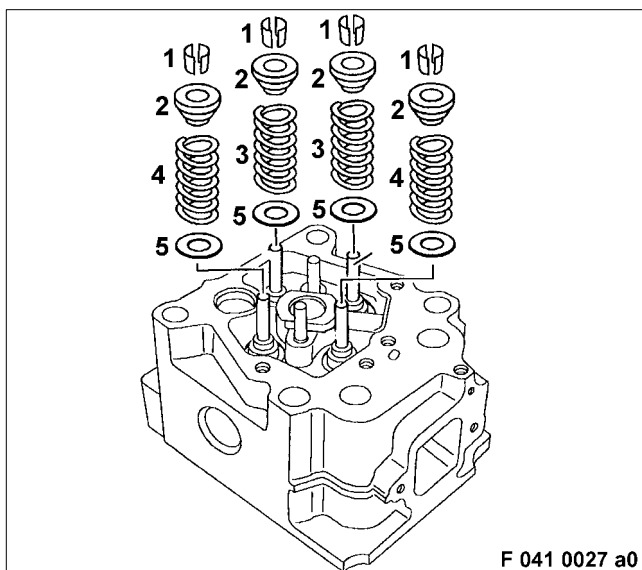

Mount valve spring seat (5) on every valve guide.

Mount valve spring (inlet)(3) and valve spring (outlet)(4) on valve spring seat with the colour marking facing upwards.

Place spring retainer (2) on valve spring.

Install valve collet (1), see next illustration.

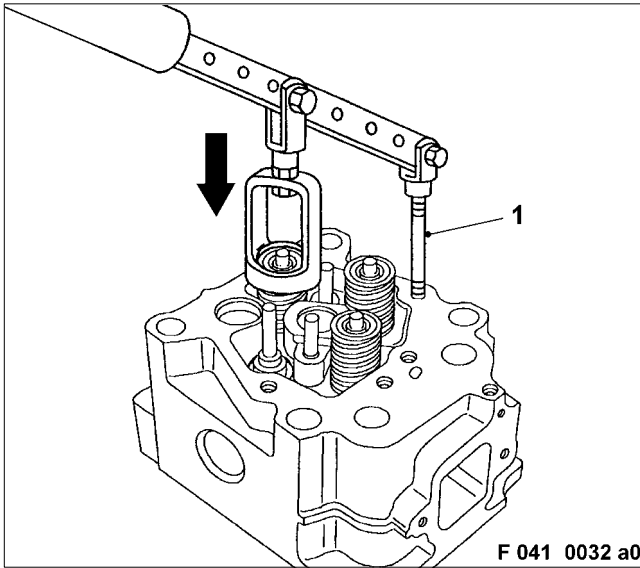

Clamp cylinder head in jig.
Insert stud (1) of valve lift into threaded bore in cylinder head.

CAUTION

**Spring pretension.
Risk of injury!
Only use specified tool.**

Press down valve spring retainer with valve lift (arrow).

Insert valve collets into spring retainers and center. Make sure that lip of valve collets is securely seated in groove at end of stem.

Release valve spring.
Remove valve lift.

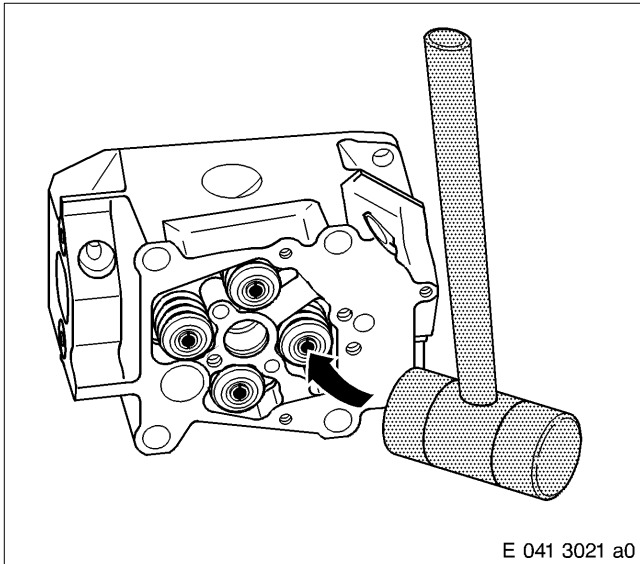

Lay cylinder head on its side.

Using a plastic mallet, lightly tap the valve stem so that valve collets are positioned correctly on the valve neck.

Measure valve clearance to cylinder head – see C 041.05.08.

If the recorded value is not within the permitted tolerances, see Tolerance and Wear Limits List, remove valves and check valve seat inserts and valve heads.

C 041.05.11 Installation

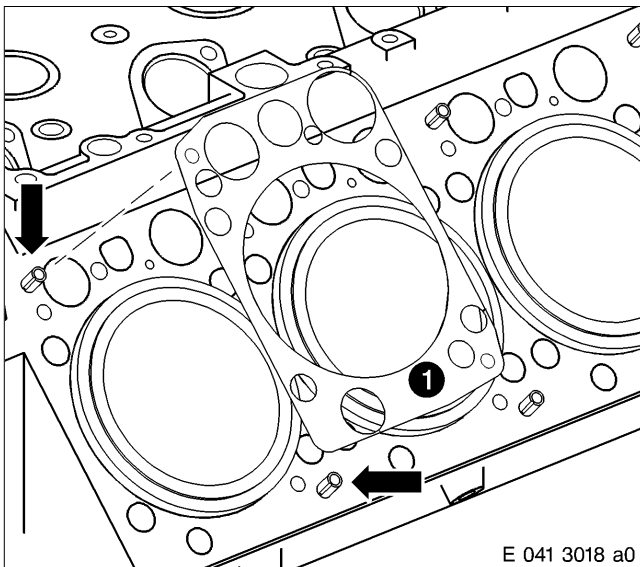

Installing cylinder head

Note: Prior to installation, remove all blanking plugs and check that oil bores are perfectly clean.

Wipe cylinder head and crankcase interface and check.

Insert new spring pins (arrows) into crankcase until they contact the stop.

Mount new cylinder head gasket (1) via spring pins on end face of crankcase as shown in illustration.

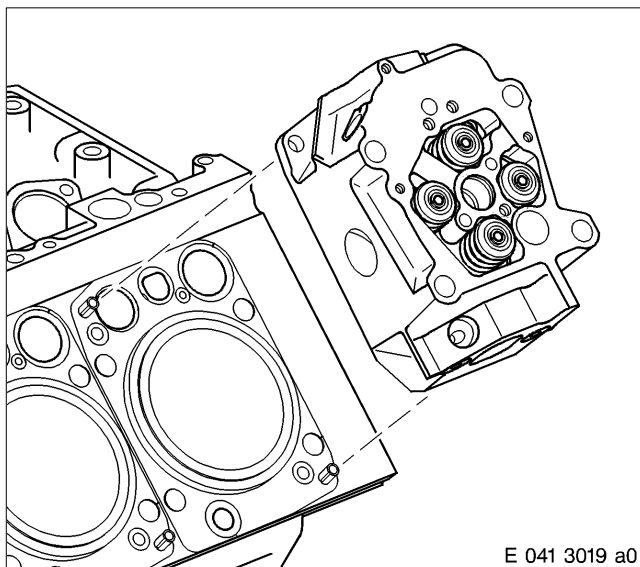

⚠ CAUTION

**Components have sharp edges.
Risk of injury!
Handle components only when wearing protective gloves.**

Mount cylinder head via spring pins on cylinder head gasket.

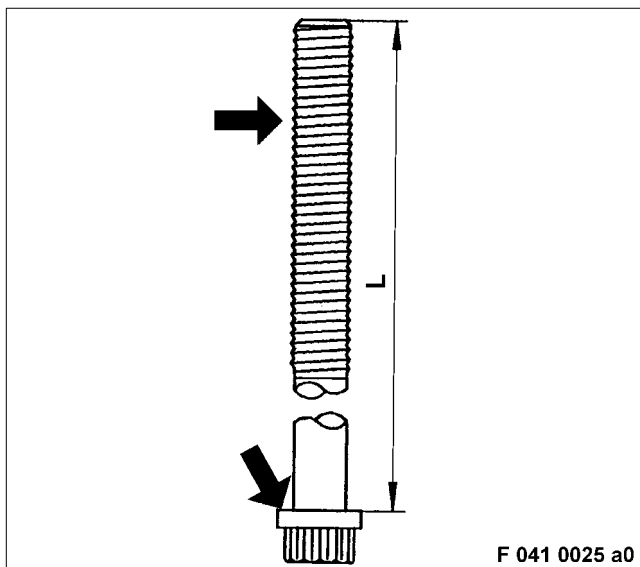

Measure shaft length (L) of double-hex screws with depth gauge.

For max. permissible shaft length – see C 041.05.01.
Coat threads and screw head seating surfaces (arrows) with engine oil.

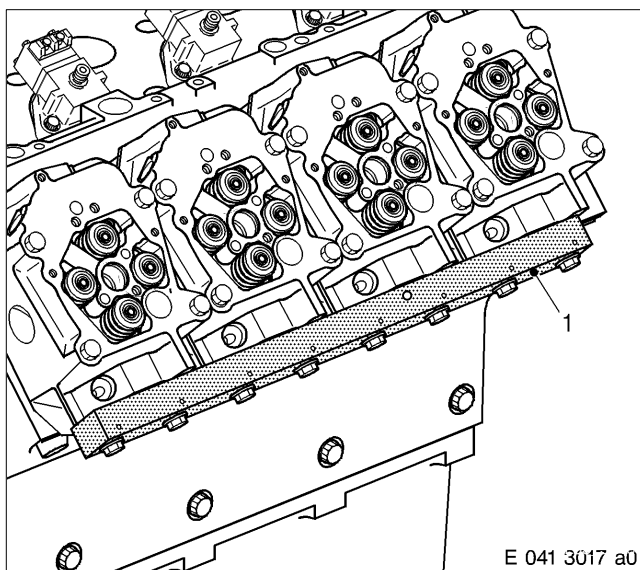

Fit double hex screws but do not tighten.

Mount alignment tool (1) on the outlet channels of the cylinder heads and tighten.

Note: Carefully align the cylinder heads; otherwise this could result in warping and cracks in the exhaust and constant-pressure manifold.

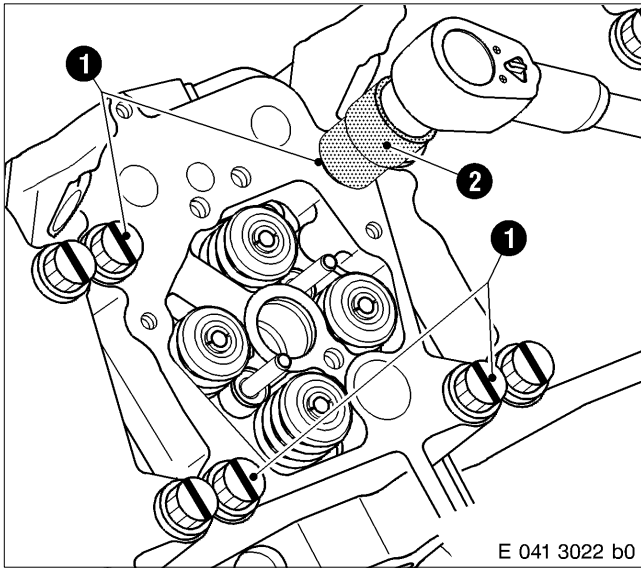

Note: To ensure that the cylinder head remains in correct position, all prescribed tightening torque stages and tightening sequence in accordance with cylinder head tightening diagram, see C 041.05.01, must be observed.

Tighten double-hex screws (1) for cylinder head with socket (2) in stages to specified pretightening torque in prescribed sequence in accordance with cylinder head tightening diagram.

Mark screw heads.

Tighten double-hex screws in specified sequence to angle of rotation in accordance with tightening specifications.

If the tightening torque or angle of rotation is exceeded for a cylinder head screw, remove all cylinder head screws, check shaft (replace cylinder head screw if necessary) and retighten to tightening specification.

Note: Cylinder head screws are not retightened!

C 041.05.12 After-Installation Operations

A distinction must be made as to whether:

- 1 — The engine was completely disassembled
- 2 — The engine is removed but was not disassembled
- 3 — The engine is installed

1	2	3	Operations	See
x	—	—	Perform operations as per Assembly Plan	B 005
x	—	—	Install engine	B 007
—	x	x	Install pushrods	C 054.05
—	x	x	Install rocker arm assembly	C 055.05
—	x	x	Adjust valve clearance	C 055.05.11
—	x	x	Connect leak-off fuel lines	C 086.05
—	x	x	Install H.P. fuel line	C 073.05
—	x	x	Install cylinder head cover	C 055.10
—	x	x	Install crankcase breather	C 018.10
—	x	x	Install exhaust manifold	C 142.05
—	x	x	Install turbocharger	C 101.01
—	x	x	Install charge air manifold	C 124.05
—	x	x	Install air system before exhaust turbocharger	—
—	x	x	Install guide tube and oil dipstick	C 182.10
—	x	x	Install filling pipe for engine oil	C 182.10
—	—	x	Fill engine coolant system	Operating Instructions
—	—	x	Release engine start	Operating Instructions

C 055.05.11 Installation

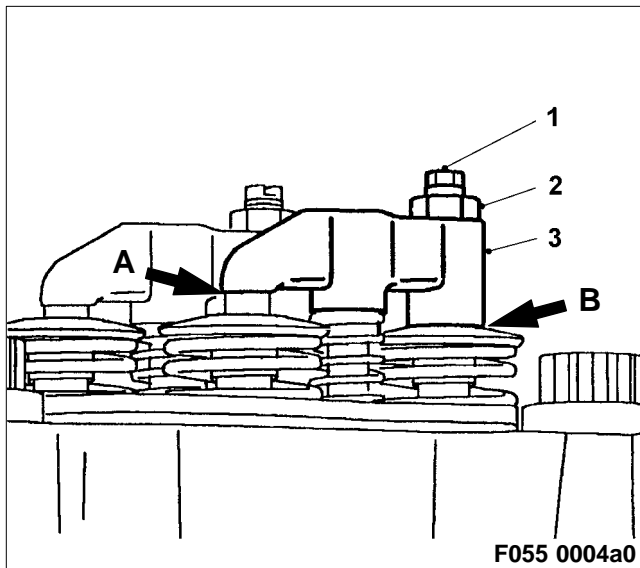

Adjusting and installing valve bridges

Note: Make sure parts are perfectly clean. Perform setting only with engine either cold or at operating temperature. Allow at least 30 minutes after engine shutdown before starting.

Measure protrusion of guide pins in cylinder head, see C 041.05.08.

Coat register bore of valve bridge (3) with engine oil.

Important: If the valve seat inserts in cylinder head or valves have been machined, the valve bridges must be adjusted.

Clamp valve bridges in vice with aluminium jaws, release locknut (2) and back off adjusting screw (1) by approx. 3 turns.

Fit valve bridge on pin in cylinder head in accordance with the markings (installation location).

Adjusting screws point to exhaust pipe.

Note: For exact adjustment, valve bridges are first installed without compression springs.

Press valve bridge downwards and hold.

Valve bridge must make contact with valve stem (A), back off adjusting screw if necessary.

Manually insert adjusting screw with valve bridge pressed until adjusting screw just contacts valve stem (B); valve bridge must not move upwards.

Tighten locknut by hand.

Important: Valve bridges are set and must not be interchanged during installation!

Remove valve bridges from cylinder head.

Clamp valve bridges in the vice and tighten locknut to specified tightening torque – see C 055.05.01.

Install spring guides and compression springs on pins in cylinder head.

Note: Ensure correct position of spring guide – see overview drawing C 055.05.01.

Fit valve bridges on pins in cylinder head in accordance with the markings (installation location).

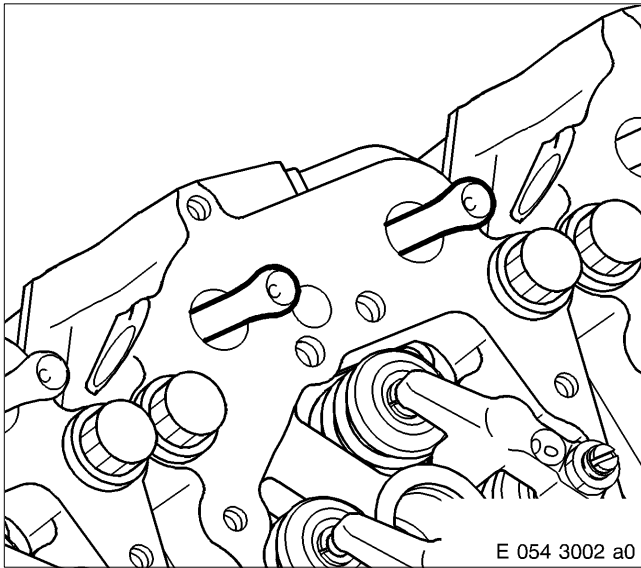

Installing rocker arm assembly

Using the barring tool, set piston of cylinder to be checked to firing TDC.

Note: In firing TDC, both roller tappets of the cylinder to be checked are in the camshaft basic circle.

Coat pushrod seats of push rods with engine oil.

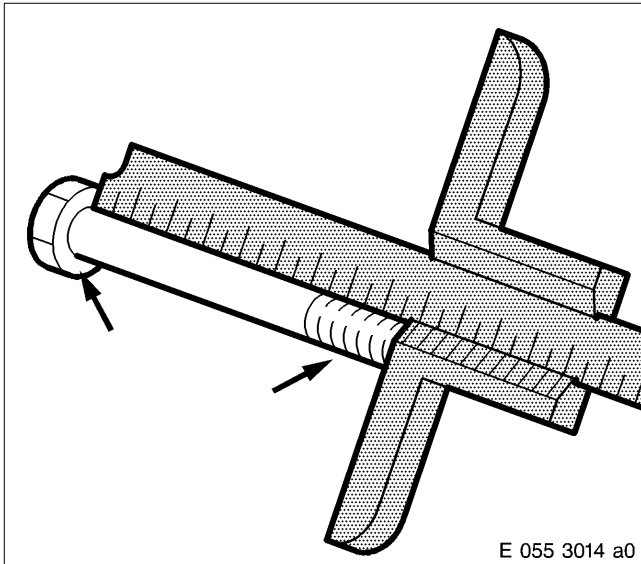

Measure shaft length of hex screw; for max. shaft length – see C 055.05.01.

Coat thread and mating face (arrows) of hex screws with engine oil.

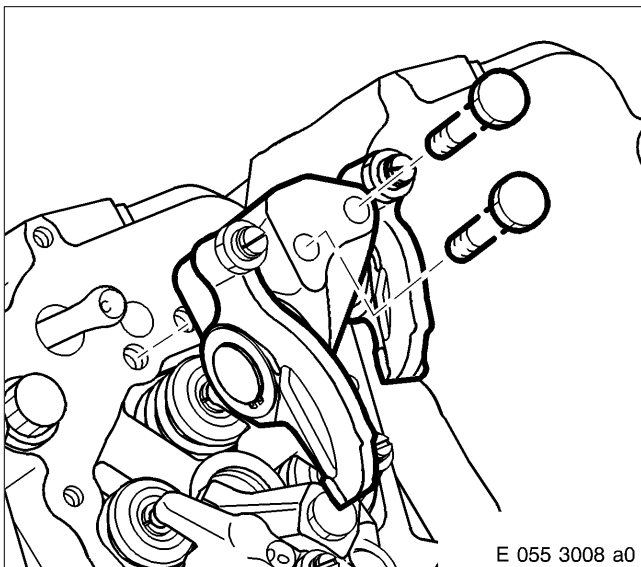

Release nuts of adjusting screws on rocker shaft support and back off adjusting screws.

Fit rocker shaft support on cylinder head and check position of tapers in push rods.

Insert hex screws into cylinder head and tighten to specified tightening torque – see C 055.05.01.

Proceeding in engine firing sequence, set other pistons to firing TDC and install all rocker arm bearing pedestals in same manner.

Set valve clearance, see following Section.

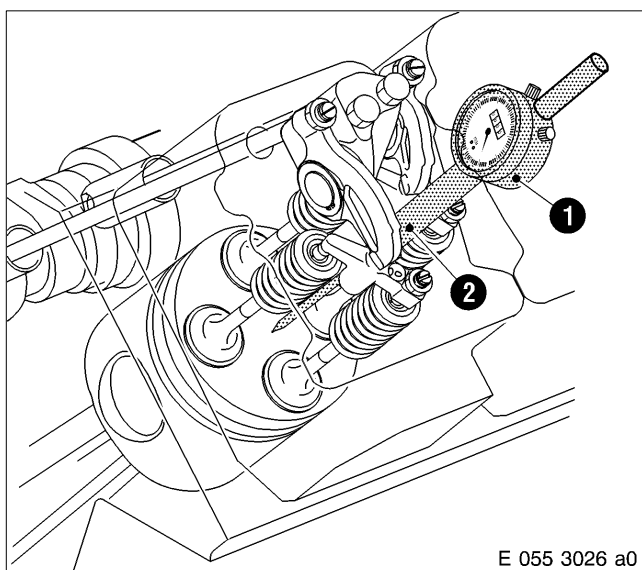

E 055 3026 a0

Adjusting valve clearance with two crankshaft positions

Install measuring unit (2) with dial gauge (1) into cylinder head A1.

Using the barring tool, turn the engine until piston A1 is precisely at TDC (pointer on dial gauge indicates the highest value).

If rocker arms on cylinder A1 are unloaded, the piston is in firing TDC.

If rocker arms on cylinder A1 are loaded, the piston is in overlap TDC.

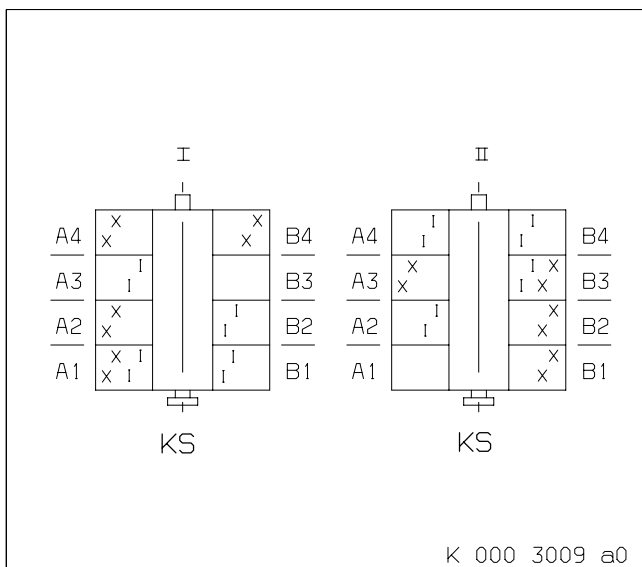

K 000 3009 a0

Set valve clearances at initial TDC crankshaft position in accordance with the adjacent valve clearance setting diagrams.

Procedure for setting – see next illustration.

Rotate crankshaft a further 360° (to second TDC crankshaft position) and set remaining valve clearances in accordance with valve clearance setting diagram.

I = Firing TDC at cylinder A1

II = Overlap TDC at cylinder A1

X = Exhaust valve

I = Inlet valve

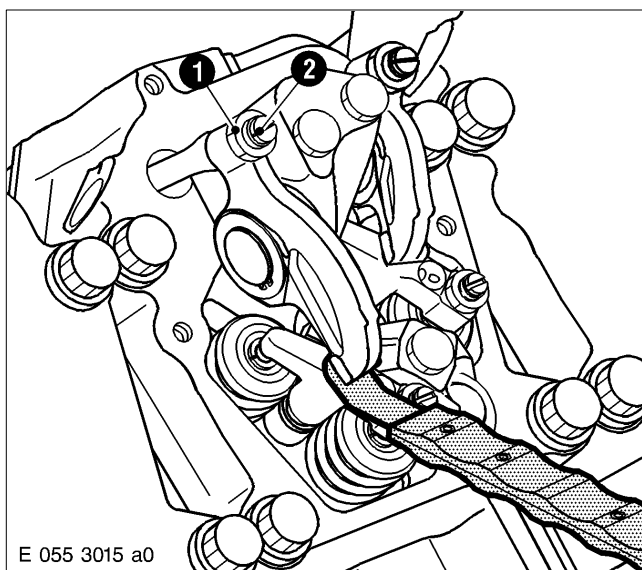

E 055 3015 a0

Release locknut (1) and slightly unscrew adjusting screw (2).

Insert feeler gauge between valve bridge and rocker arm.

For specified valve clearance – see A 004.

Set adjusting screw so that the feeler gauge can just be pulled through when locknut is tightened.

Tighten locknut to specified tightening torque – see C 055.05.01; when doing this, hold adjusting screw in position with a screwdriver.

Recheck valve clearance after locking nut.

Note: Remove barring tool before starting the engine and mount end cover.



C 055.05.12 After-Installation Operations

A distinction must be made as to whether:

- 1 ————— The engine was completely disassembled
- 2 ————— The engine is removed but was not disassembled
- 3 ————— The engine is installed

1	2	3	Operations	See
x	-	-	Perform operations as per Assembly Plan	B 005
x	-	-	Install engine	B 007
-	x	x	Install cylinder head cover	C 055.10
-	-	x	Release engine start	Operating Instructions

Contents

C 070 Fuel system – high-pressure

C 073.05 Injection pump

- C 073.05.01 Overview drawing
- C 073.05.02 Special tool
- C 073.05.04 Before-removal operations
- C 073.05.05 Removal
- C 073.05.06 Disassembly
- C 073.05.08 Inspection and repair
- C 073.05.11 Installation
- C 073.05.12 After-installation operations

C 075.05 Fuel injector and H.P. fuel line

- C 075.05.01 Overview drawing
- C 075.05.02 Special tool
- C 075.05.04 Before-removal operations
- C 075.05.05 Removal
- C 075.05.06 Disassembly
- C 075.05.08 Inspection and repair
- C 075.05.11 Installation
- C 075.05.12 After-installation operations

C 070 Fuel System – High-Pressure

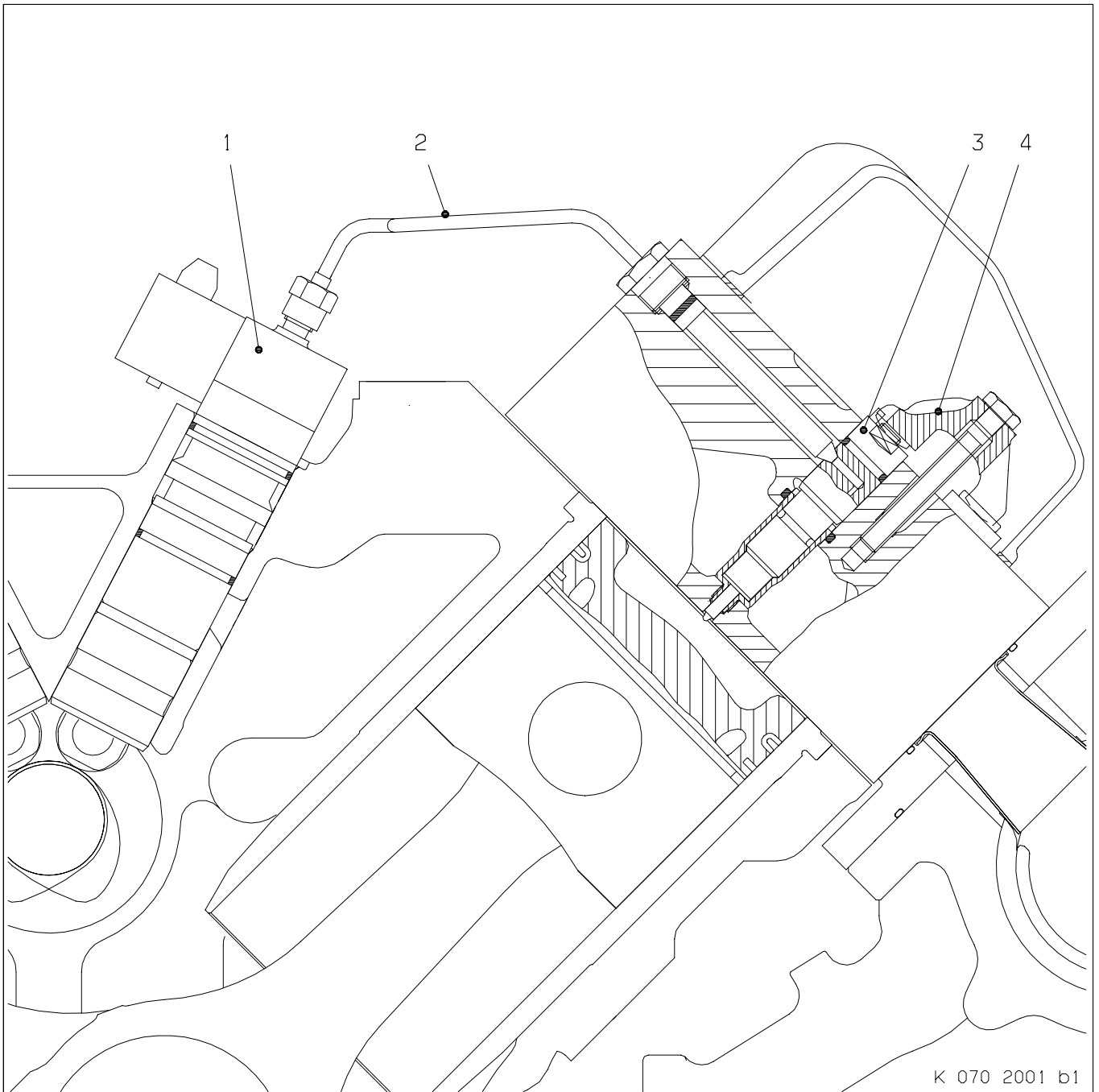

- 1 Plug-in pump
- 2 H.P. line
- 3 Injector
- 4 Clamping element

C 073.05.06 Disassembly

Injection pump must not be disassembled.

C 073.05.08 Inspection and Repair

Replace injection pump in accordance with maintenance schedule during appropriate maintenance echelon.



CAUTION

Compressed air is air which has been compressed under pressure. If compressed air is used for blowing out or blow-drying components, always wear protective goggles or safety mask. Compressed air must not be directed at the body. The pressure must not exceed 3.0 bar (40 lb/in²).

When re-using injection pump, clean with cleaning agent, blow out with compressed air and make sure it is perfectly clean.

Make visible inspection of injection pump for wear and damage paying particular attention to the running surface of the roller; replace injection pump if it is worn or damaged.

Clean double-hex screws and check condition of screws.

Make sure threads are in perfect condition; replace double hex screws as necessary.

Check condition of wiring; replace if necessary.

Replace sealing rings as part of every assembly.

C 073.05.11 Installation

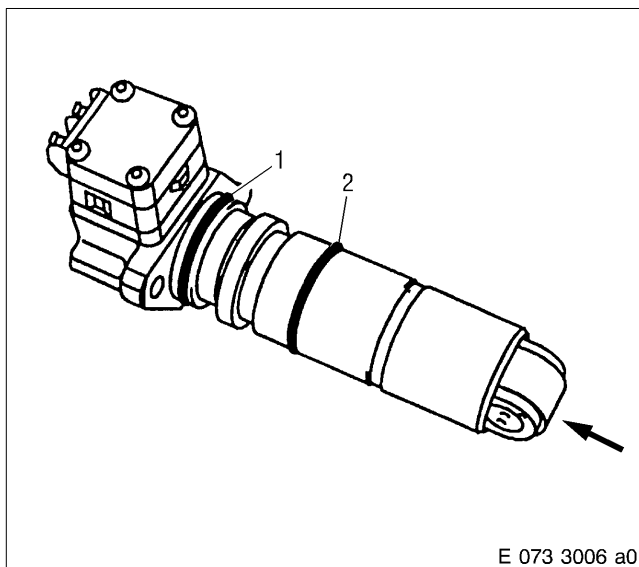

Installing injection pump

Note: Make sure parts are perfectly clean.

Coat both O-rings (1) and (2) with petroleum jelly and fit on injection pump.

Note: O-rings have different item numbers. Make sure that installation position is correct.

Coat roller (arrow) of injection pump with engine oil.

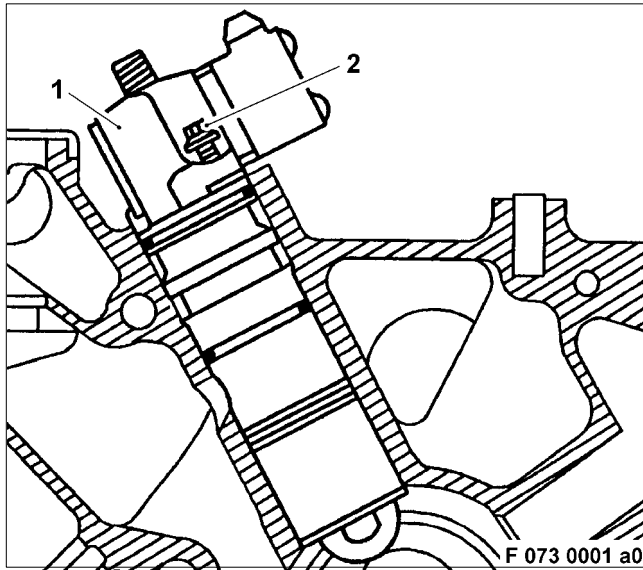

Note: Before installing, remove all blanking plugs and covers.

Check that sealing surfaces and fuel bores in the crankcase are perfectly clean; clean if necessary.

Using the engine barring tool, set pump cams of camshaft to base circle.

Arrange injection pump (1) with respect to installation location and manually press into crankcase against spring power (distance approx. 4 mm).

Note: If a new injection pump is installed, coding must be entered into the engine control system – see DCC or MTU Elektronik Documentation.

Insert both double-hex screws (2) with socket and extension uniformly and tighten to specified tightening torque – see C 073.05.01.

Attach plug-in clip of wiring to solenoid valve and tighten screws to specified tightening torque – see A 003.

C 073.05.12 After-Installation Operations

A distinction must be made as to whether:

- 1 — The engine was completely disassembled
- 2 — The engine is removed but was not disassembled
- 3 — The engine is installed

1	2	3	Operations	See
x	–	–	Perform operations as per Assembly Plan	B 005
x	–	–	Install engine	B 007
–	x	x	Install H.P. line	C 075.05
–	x	x	Install charge air manifold	C 124.05
–	x	x	Install crankcase breather	C 018.10
–	x	x	Install ECU housing and bracket	Special Publication
–	x	x	Connect electric cables	–
–	–	x	Release engine start	Operating Instructions

C 075.05 Injector, Injection Line

C 075.05.01 Overview Drawing

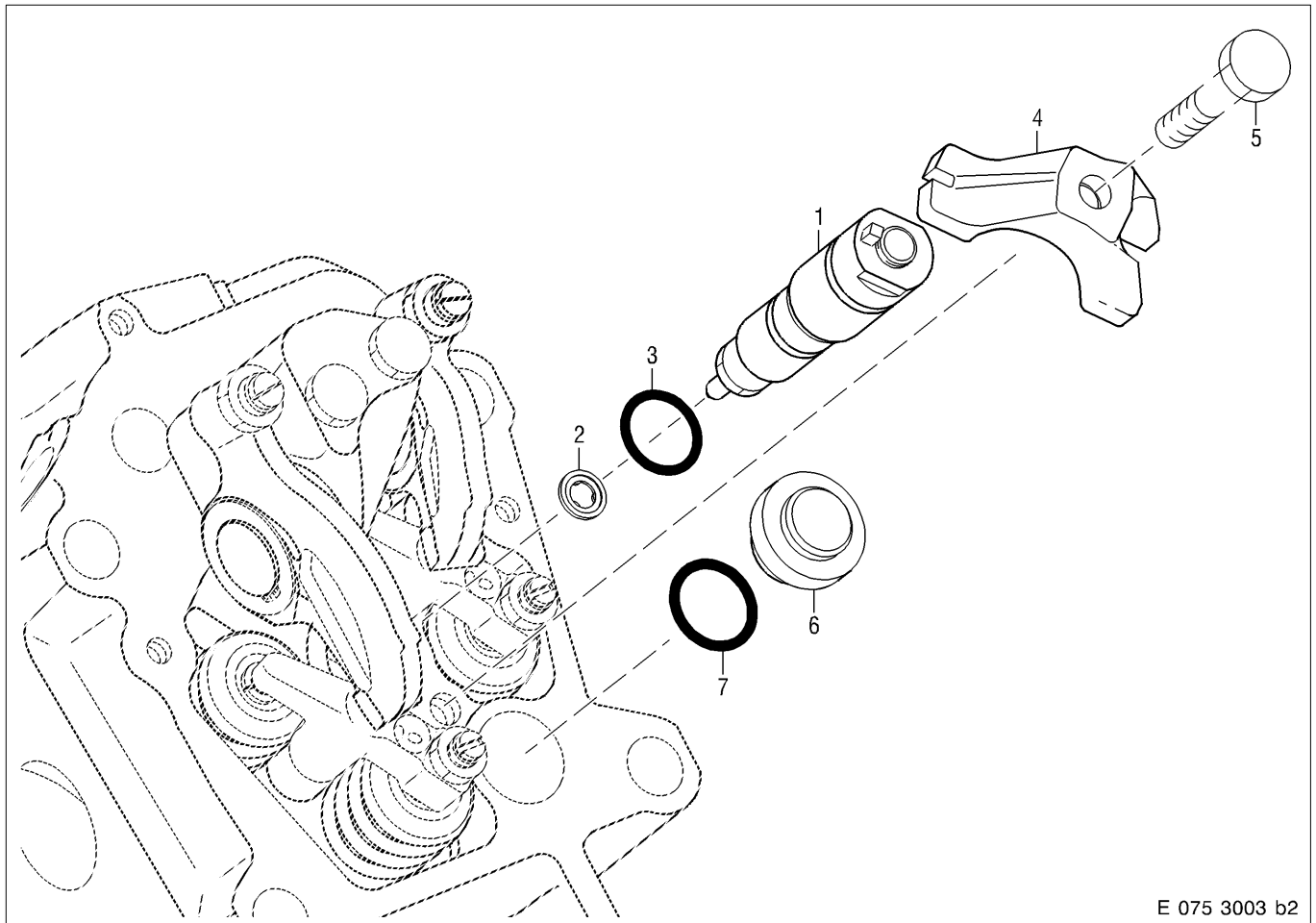

E 075 3003 b2

- 1 Injector
- 2 Sealing ring
- 3 O-ring
- 4 Clamping element

- 5 Hex screw
Tightening torque: 50 Nm
Lubricant: Engine oil
- 6 End cover
- 7 Sealing ring

Injection line

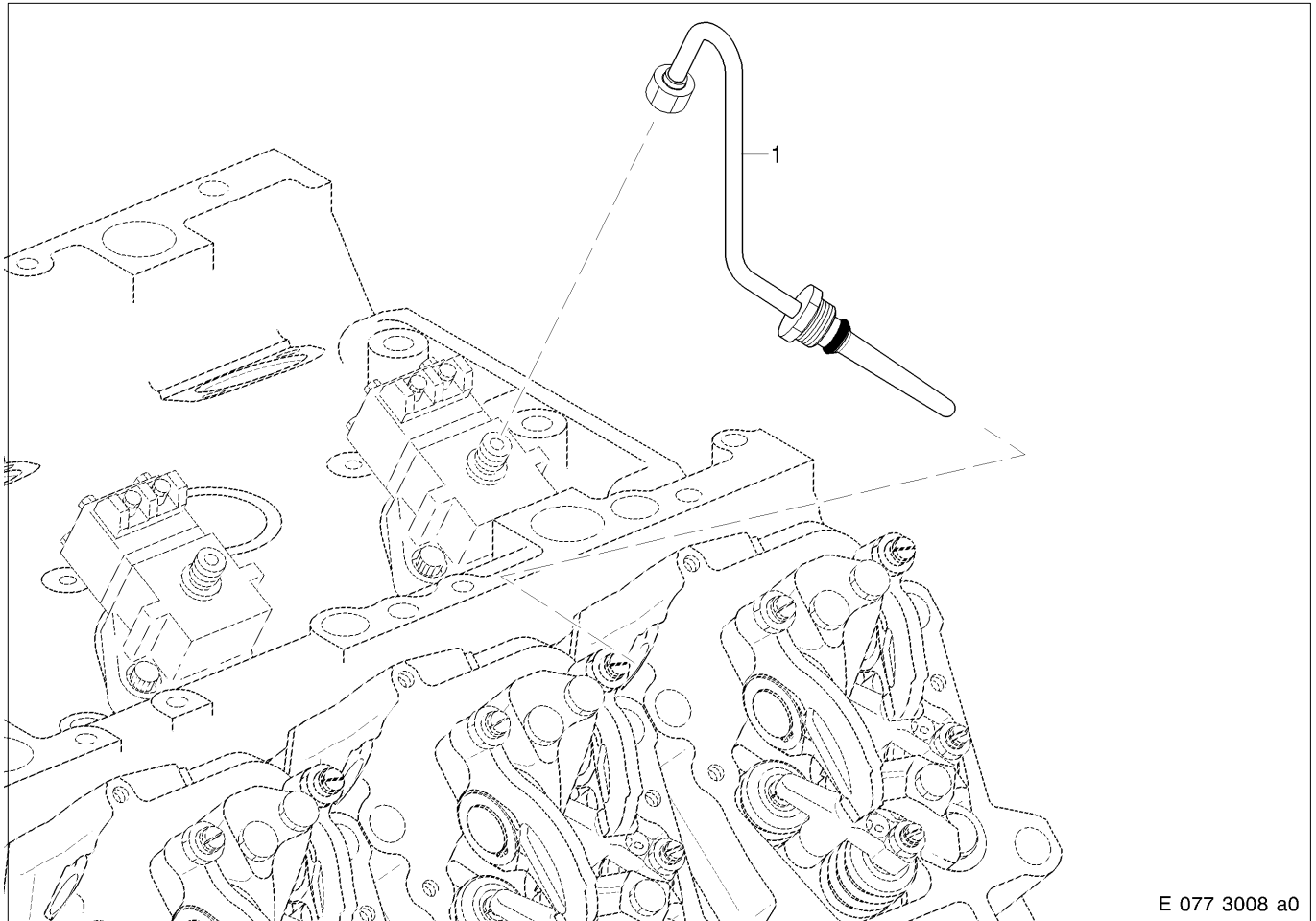

- 1 H.P. line
- Union nut on injection pump:
Tightening torque: 25 Nm + 2 Nm
- Adapter in cylinder head:
Tightening torque: 40 Nm
- Lubricant: Engine oil

C 075.05.02 Special Tool

Designation – Application	Number
Ring wrench insert for union nuts	1
Fuel suction lift	1
Removal tool for injector	1

C 075.05.04 Before-Removal Operations

A distinction must be made as to whether:

- 1 ————— The engine is to be completely disassembled
- 2 ————— The engine is to be removed but not disassembled
- 3 ————— The engine is to remain installed

1	2	3	Operations	See
x	–	–	Remove engine	B 003
x	–	–	Perform operations as per Disassembly Plan	B 004
–	–	x	Disable engine start	Operating Instructions
–	x	x	Remove oil separator (if necessary)	C 018.10
–	x	x	Remove leak-off fuel line	C 086.05
–	x	x	Remove cylinder head cover	C 055.10

C 075.05.05 Removal

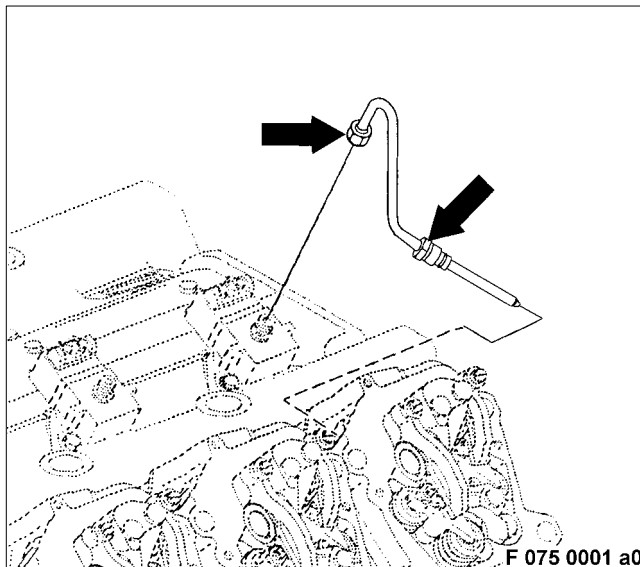

Removing H.P. fuel lines and fuel injectors

! WARNING

Fuels and fuel vapours are flammable and poisonous. Risk of fire, explosions and poisoning!

When using fuel:

- do not use naked flame, – no electric sparks,
- do not smoke, – do not spill fuel. Do not inhale.

Always wear protective gloves and protective goggles/safety mask. Ventilate working area well.

Remove union nut and adapter (arrow).
Withdraw H.P. line from cylinder head.
Using a sprayer and rubber hose, drain fuel in the two free bores.

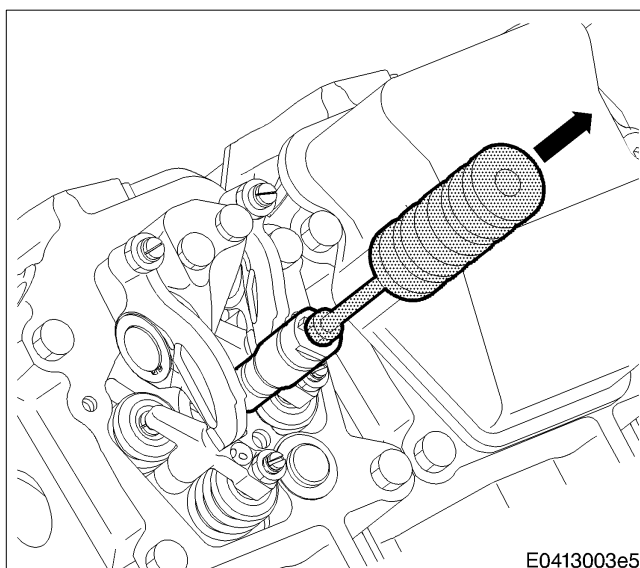

Remove securing screw for clamping element (see Overview Drawing C 075.05.01) and remove clamping element.
Install injector removal tool in injector.
Remove injector by means of removal tool.
Using a wire hook, remove sealing ring (copper) or withdraw from injector.
Remove sealing ring from injector.

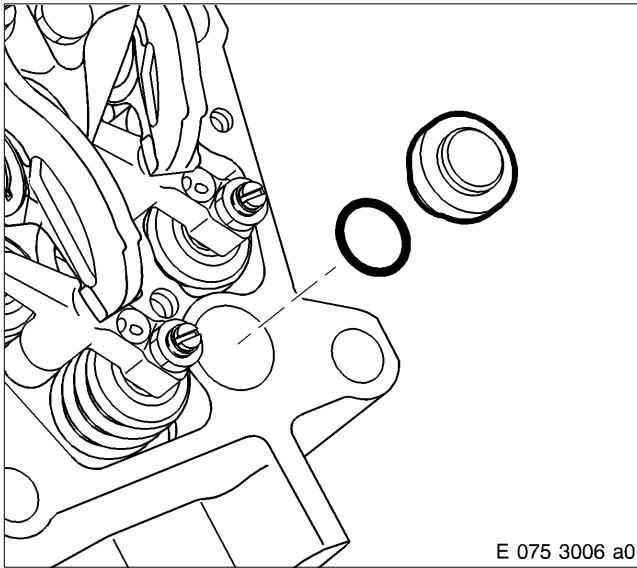

Removing end cover for clamping element in cylinder head

Using a screw driver, carefully remove end cover from cylinder head.
Remove sealing ring.

C 075.05.06 Disassembly

Injection must not be disassembled.

C 075.05.08 Inspection and Repair

Note: Make sure fuel-carrying components are perfectly clean.

Replace injector in accordance with maintenance schedule during appropriate maintenance echelon.

Clean all parts.

When re-using injector, check it externally for damage and replace if necessary.



CAUTION

Compressed air is air which has been compressed under pressure. If compressed air is used for blowing out or blow-drying components, always wear protective goggles or safety mask. Compressed air must not be directed at the body. The pressure must not exceed 3.0 bar (40 lb/in²).

Blow out H.P. line with compressed air and make sure it is perfectly clean.

Using the magnetic crack-testing method with fluorescent magnetic powder, check hex screw and clamping element for cracks; replace components as necessary.

Check seating faces of clamping element and end cover; if necessary rub down with an oilstone or emery cloth. Replace components as necessary.

Check hex screws for damage and check threads for ease of movement; replace hex screw if necessary.

Check sealing cones and threads on H.P. fuel line for damage and wear; replace H.P. fuel line if necessary.

Note: Do not bend the H.P. line!

Replace sealing rings and O-rings at every assembly.

C 075.05.11 Installation

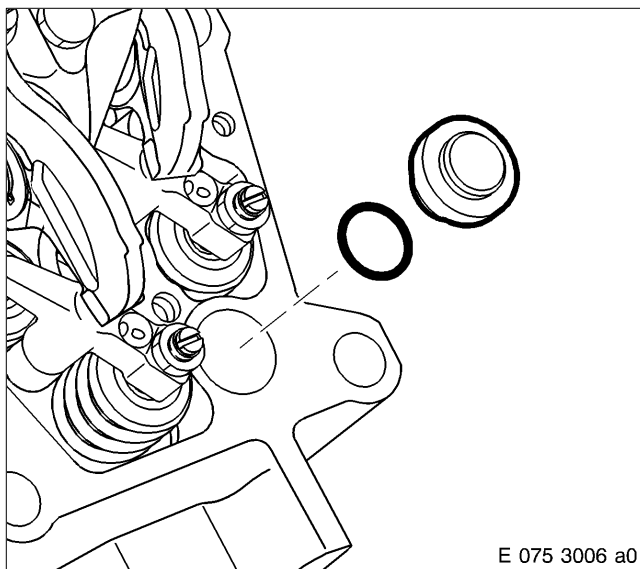

Installing end cover for clamping element in cylinder head

Coat sealing ring with petroleum jelly and insert in groove on end cover.

Insert end cover into bore in cylinder head.

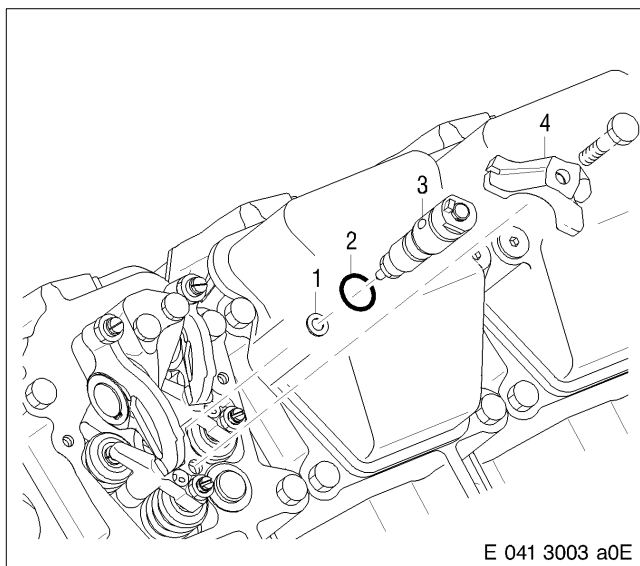

Installing fuel injectors and injection lines

Note: Make sure fuel-carrying components are perfectly clean. Prior to installation, remove all blanking plug and/or covers.

! WARNING

Fuels and fuel vapours are flammable and poisonous. Risk of fire, explosions and poisoning!
When using fuel:
– do not use naked flame, – no electric sparks,
– do not smoke, – do not spill fuel. Do not inhale.
Always wear protective gloves and protective goggles/safety mask. Ventilate working area well.

Bar engine several times to blow out any remaining fuel.

Check sealing surface on cylinder head and nozzle holder; clean if necessary.

Coat new O-ring (2) with petroleum jelly and fit on injector (3).

Note: The copper sealing ring (1) can be installed any way round.

Fit new copper sealing ring on injector, if necessary using grease as adhesive.

Press injector into cylinder head by hand. Ensure that pin in injector is at 11 o'clock position with regard to engine longitudinal axis. Installation direction – see next illustration.

Install clamping element (2) with hex screw, ensuring that it is positioned correctly and that it is perfectly seated on injector and end cover.

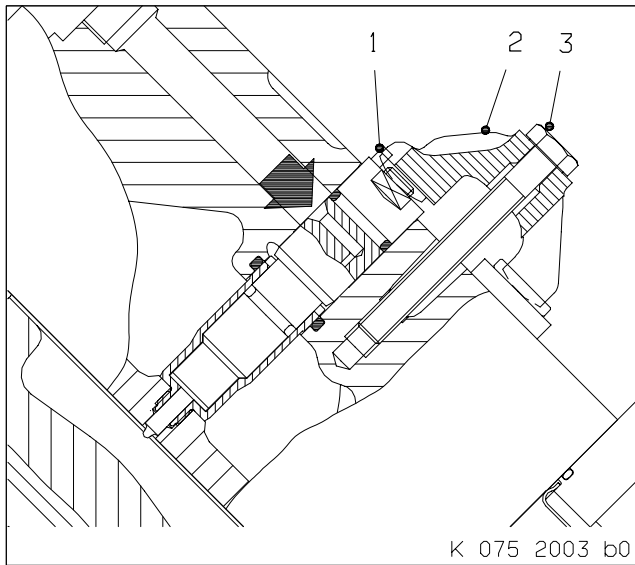

The injector supply bore must point in the installation direction (arrow) of the pressure pipe connection.
 Pin (1) in injector must be located in clamping element (2) recess.
 The fork on the clamping element must engage in the end cover.
 Tighten hex screw (3) to specified tightening torque – see C 075.05.01.

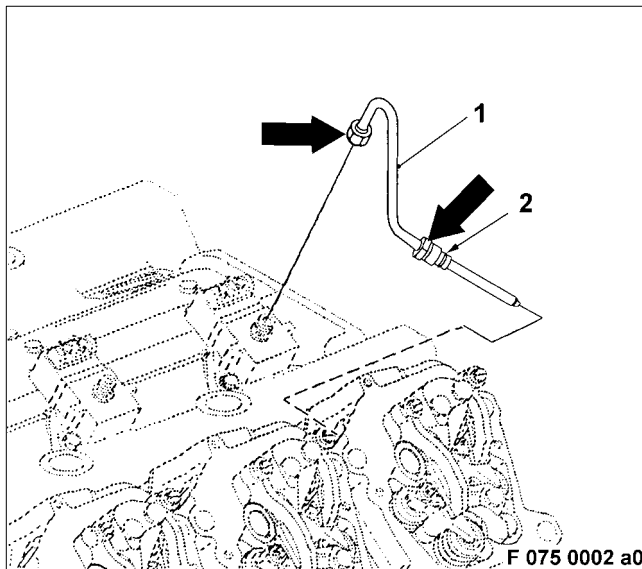

Coat O-ring (2) in H.P. fuel line (1) with petroleum jelly.
 Insert H.P. line into cylinder head, screw union nut and adapter (arrow) into position and tighten by hand.
 First tighten union nut (on injection pump) and then screw-in connection (in cylinder head) to specified tightening torque – see C 075.05.01.
Note: After engine start, visually inspect fuel system for leaks.

C 075.05.12 After-Installation Operations

A distinction must be made as to whether:

- 1 — The engine was completely disassembled
- 2 — The engine is removed but was not disassembled
- 3 — The engine is installed

1	2	3	Operations	See
x	–	–	Perform operations as per Assembly Plan	B 005
x	–	–	Install engine	B 007
–	x	x	Install cylinder head cover	C 055.10
–	x	x	Install leak-off fuel line	C 086.05
–	x	x	Install oil separator	C 018.10
–	–	x	Release engine start	Operating Instructions

A 080 Abbreviations

ATL	Abgasturbolader
brit.	britisch
bzw.	beziehungsweise
DBR	Drehzahlbegrenzungsregler
DDC	Detroit Diesel Corporation
d. h.	das heißt
DIN	Deutsche Industrie-Norm
ECS	Engine Control System
ECU	Engine Control Unit
ISO	International Organization for Standardisation
KGS	Freie Seite (Kraftgegenseite)
KS	Antriebsseite (Kraftseite)
KW	Kurbelwelle
LLK	Ladeluftkühler
MTU	Motoren- und Turbinen- Union
NW	Nockenwelle
SSK	Schnellschlußklappe
usw.	und so weiter
UT	Unterer Totpunkt
WP	Wasserpumpe

A090 Keyword Index

A		E	
Abbreviations	A 008	Engine assembly	B 005
Acceptance test record	B 006	Engine carrier	C 213.05
Air compressor	C 360.40	Engine coolant lines	C 202.10
Air filter	C 121.01	Engine coolant pump	C 202.05
Air intake / air supply	C 120	Engine disassembly	B 004
Air supply to cylinders	C 124.05	Engine disassembly	B 004
Assembly instructions, general	A	Engine drawings	B 008
Assembly, engine	B 005	Engine governor – see special publication	
Attachments, crankcase	C 010	Engine installation	B 007
Auxiliary systems, supplementary units	C 360	Engine installation and initial operation	B 007
Axial mounting of crankshaft	C 031.05	Engine layout	B 008
		Engine lifting device	C 015.05
		Engine mount	C 231.05
		Engine operation	B 007
		Engine operation	B 007
		Engine removal	B 003
		Engine removal	B 003
		Engine sides, designation	A 002
		Exhaust elbow	C 142.05
		Exhaust manifold	C 142.05
		Exhaust system	C 140
		Exhaust turbocharger	C 100
B		F	
Bearing bush, camshaft	C 011	Fan drive	C 221.05
Bearing cap (see crankshaft bearing cap)		Filter element (see fuel filter)	
Bearing pedestal, rocker arm	C 055.05	Friction washer, crankshaft	C 031.05
Belt drive	C 028.05	Fuel filter	C 083.05
Belt pulley for fan	C 028.05 C 035.05	Fuel injection pump (see injection pump)	
		Fuel injector (see injector)	
Belt pulley for generator	C 213.05	Fuel lines before fuel pump	C 081.05
Belt tensioner for fan	C 221.05	Fuel lines from pump to filter	C 082.05
		Fuel pressure relief valve	C 084.05
		Fuel pump	C 081.05
		Fuel system (low pressure)	C 080
C		G	
Camshaft	C 051.05	Gear case cover	C 024.05
Camshaft bearing bush	C 011.05	Gear case, free end	C 024.05
Camshaft gear	C 051.05	Gear train	C 020
Charge air manifold	C 124.01	Gear train, driving end	C 022.05
Checking camshaft timing	C 051.05.11	Gear train, free end	C 025.05
Compressor (see air compressor)		General	A
Conrod bearing shell	C 037.05	Generator	C 213.05
Coolant pump (see engine coolant pump)		Generator drive	C 028.05
Coolant thermostat (see thermostat insert)		Governor (see governor)	
Cooler, charge air	C 110	Group summary	C
Cooling air system	C 220		
Cooling system	C 200		
Counterweight, crankshaft	C 031.05		
Coupling	C 250	H	
Crankcase	C 011.05	H.P. line	C 075.05
Crankcase and externally mounted components	C 010	Hub, free end	C 035.05
Crankcase ventilation	C 018.10		
Crankshaft	C 031.05		
Crankshaft bearing shell	C 031.05		
Crankshaft gear, driving end	C 031.05		
Crankshaft gear, free end	C 031.05		
Crankshaft main bearing bore	C 011.05		
D			
Dangers at working area	A 005		
Data sheets	A 006		
Defining piston TDC	C 051.05.11		
Designation of engine sides and cylinders	A 002		

I		Rocker arm assembly	C 055.05
		Run-in program	B 006
Injection line	C 075.05	Running gear (see running gear)	
Injection pump	C 073.05	Running-in	B 006
Injection system – high-pressure	C 070		
Injector	C 075.05	S	
Intercooler	C 111.05	Set V-belt tension	C 028.05.11
Intercooler	C 110	Settings	A 004
		Starter	C 172.05
		Starter ring	C 032.05
		Starting system	C 170
L		T	
Leak-off fuel line	C 086.05	Tightening specifications for screws, bolts and nuts	A 003
Lifting attachments for engine and running gear	C 015.05	Transverse sectional view, engine	B 008
Lines, lube oil pump	C 181.05		
M		V	
Main bearing cap	C 011.05	V-belts	C 028.05
Measuring piston protrusion	C 037.05.11		
Mechanical fan drive	C 221.05		
Mounting/support	C 230		
O			
Oil cooler (see oil heat exchanger)			
Oil dipstick	C 182.10		
Oil filler pipe	C 182.10		
Oil filter	C 183.05		
Oil heat exchanger	C 183.05		
Oil lines	C 181.20		
Oil pan	C 014.05		
Oil pressure relief valve	C 181.05		
Oil pump (see lube oil pump)			
Oil return lines, exhaust turbocharger	C 185.25		
Oil return to oil pan	C 024.05		
Oil separator	C 018.10		
Oil spray nozzle, piston cooling	C 184.10		
Oil suction line	C 181.05		
Oil supply lines, turbocharger	C 185.10		
Oil-pressure regulating valve	C 181.05		
Operation schedules	B		
P			
Piston cooling	C 184.10		
Piston rings	C 037.05		
Pistons and conrods	C 037.05		
Pistons and conrods	C 037.05		
Pressure testing coolant chamber	C 200.08		
PTO systems, driving end and free end	C 250		
PTO, driving end	C 032.05		
PTO, free end	C 035.05		
Publication summary	A 008		
R			
Radial-lip shaft seal for crankshaft	C 032.05		
Repairing threaded bores	A 009		
Rocker	C 055.05		

R		V	
Radial-lip shaft seal for crankshaft	C 032.05	V-belts	C 028.05
Recondition valve seat inserts	C 041.05.08	Valve bridge	C 055.05
Repairing threaded bores	009 A	Valve drive	C 055.05
Rocker arm	C 055.05	Valve gear	C 050
Rocker arm assembly	C 055.05	Valve gear (see valve gear)	
Run-in program	B 006	Valve roller tappets	C 054.05
Running gear	C 030	Vibration damper	C 035.05
Running gear (see running gear)			
Running gear and engine lifting attachments	C 015.05		
Running-in	B 006		
		W	
		W5 Maintenance Operations	B 002
S			
Set V-belt tension	C 028.05.11		
Settings	004 A		
Shock absorber	C 231.05		
Starter	C 172.05		
Starter ring	C 032.05		
Starting system	C 170		
Supplementary units, auxiliary systems	C 360		
T			
Thermostat	C 206.05		
Thermostat insert	C 206.05		
Torque specifications for screws and nuts	003 A		
Transverse sectional view, engine	B 008		

Contents

B 001	Checking Engine Condition before W5 Overhaul and Major Overhaul
B 002	W5 Maintenance Operations
B 003	Engine Removal
B 004	Engine Assembly
B 005	Engine Assembly
B 006	Engine Running-In
B 007	Engine Installation and Operation
B 008	Engine Drawings



B 001 Checking Engine Condition before W5 Overhaul and Main Overhaul

Before the engine is removed, a brief test should be conducted to assist in evaluating its condition and running behaviour. Deviations from the Engine Acceptance Test Record Data found during the test run provide valuable information for subsequent overhaul services.

Operations to be performed	See
Perform operations preparatory to starting the engine	Operating Instructions
Start engine	Operating Instructions
Carry out engine warm-up procedure	Operating Instructions
Test engine at highest possible power	–
Check engine speed, temperatures and pressures where gauges are installed	–
Check operating states with fault recorder, assess discrepancies	Operating Instructions
Check running noises; these should be restricted to normal operating sounds	–
During test run, visually inspect engine and external lines for leaks	Operating Instructions
Exhaust gas colour check	Operating Instructions
Operate engine with adjustable zero-power speed	–
Connect fuel line connections for leaks	–
Cylinder head cover removal	C 055.05
Check valve gear lubrication (visual inspection)	–
Extract sample of engine oil	Operating Instructions
Analyze engine oil sample (spot test, water content, dilution with fuel)	MTU Test Kit
Extract sample of coolant	Operating Instructions
Analyze coolant sample	MTU Test Kit
Check operation of monitoring system and ECS	Operating Instructions
Shut down engine	Operating Instructions
Reduce coolant level in expansion tank and check level switch trip point (coolant level monitoring)	Operating Instructions
Drain coolant	Operating Instructions
Fill system with cleaning solution	Special Publication
Start engine	Operating Instructions
Flush cooling system	Special Publication
Shut down engine	Operating Instructions
Check compression pressure	Operating Instructions



B 002 W5 Maintenance Operations

Operations to be performed	See
Shut off fuel supply line Switch off monitoring system Switch off battery main switch Wash plant, without using chemical cleaning agents Drain engine coolant Drain charge air coolant*	– Operating Instructions Operating Instructions Operating Instructions Operating Instructions –
Drain engine oil Replace engine oil filter	Operating Instructions Operating Instructions
Replace fuel filter Replace filter elements of fuel prefilter	Operating Instructions Operating Instructions
Clean air filter, drain dust collection box and replace filter as necessary	–
Remove air supply pipework, clean, replace gaskets	–
Check condition of exhaust system	Operating Instructions
Remove, overhaul or exchange exhaust turbocharger	C 101.01 Special Publication
Remove intercooler, clean and check for leaks	C 111.05
Clean engine coolant cooler, check for leaks	Special Publication
Replace engine coolant thermostat	C 206.05
Remove, overhaul or replace engine coolant pump	C 202.05
Remove, overhaul or replace charge air coolant pump*	–
Check condition of engine control system and wiring and check for security	–
Check wiring and connections of starter	–
Check wiring and connections of generator	–
Check condition and voltage of generator drive belt	Operating Instructions
Check condition and voltage of generator fan	Operating Instructions
Remove and check fuel injection pumps	Operating Instructions
Remove valve drive Remove valve roller tappets and pushrods Check individual components, repair or replace as necessary	C 055.05 C 054.05 C 054.05.08 C 055.05.08
Remove and check fuel injectors	Operating Instructions
Carry out endoscopic inspection on cylinder chambers	Operating Instructions
Check condition of vibration damper (visual inspection)	C 035.05.08



Operations to be performed	See
Check oil separator (visual inspection)	Operating Instructions
Check securing screws of mounting for security	Operating Instructions
Check condition of resilient mounting (visual inspection)	Operating Instructions
Remove monitoring devices and check (trip settings)	Operating Instructions
Reassemble subassemblies and reinstall as per engine assembly schedule	EOM 005
Lubricate lubrication points	Operating Instructions
Fill engine oil system Fill engine coolant system Fill charge air coolant system* Perform operations preparatory to engine start	Operating Instructions Operating Instructions – Operating Instructions
Start engine Perform checks with engine running as for initial operation	Operating Instructions Operating Instructions

* – not always applicable (order-specific) –

B 003 Engine Removal

Operations	See
Shut off fuel supply	Operating Instructions
Drain engine oil, if possible while engine is warm Examine oil sludge for metallic residues Drain engine coolant when temperature of coolant is below 60 °C Drain charge air coolant*	Operating Instructions Operating Instructions Operating Instructions –
Wash plant, without using chemical cleaning agents	–
Disconnect all connections Seal open connections with non-linting plugs and covers Release engine securing screws Remove engine and place on trestles Using a lifting device, attach engine only on suspension brackets provided as shown in installation drawing, taking centre of gravity and transportation specifications into consideration.	– – – – –

* – not always applicable (order-specific) –

Engine weight

(dry weight)
 approx. 1500 kg



B 004 Engine Disassembly

Before beginning complete engine disassembly, it is advisable to take photographs of the engine from all sides or to record all components installed on the engine in writing.

The sequence of the required operations in the following list corresponds to the order in which actual disassembly is to be carried out.

The individual tasks are described in detail in the Groups listed in the right-hand column.

Operations to be performed	See
Install engine in assembly frame	–
Mark and disconnect electric cables	–
Remove ECU housing and bracket	Special Publication
Remove monitoring equipment	Special Publication
Remove crankcase breather	C 018.10
Remove charge air coolant line*	–
Remove charge air coolant pump *	–
Remove oil dipstick and oil filler tube	C 182.10
Remove connecting housing, top (intercooler)	C 111.05
Remove charge air manifold	C 124.05
Remove engine coolant line	C 202.10
Remove fan drive V-ribbed belt*	C 028.05
Remove generator V-ribbed belt	C 028.05
Remove generator	C 213.05
Remove carrier for fan drive, bearing unit and belt tensioner*	C 221.05
Remove vibration damper and belt pulley	C 035.05
Remove air compressor *	C 362.40
›Remove starter	C 172.05
Remove oil supply lines to turbochargers	C 185.10
Remove oil return lines for turbochargers	C 185.25
Remove exhaust turbocharger	C 101.01
Remove exhaust manifolds	C 142.05
Remove intercooler	C 111.05
Remove cylinder head cover	C 055.10
Remove engine lifting fixture	C 015.05
Remove fuel line	C 082.05
Remove fuel line and fuel delivery pump	C 081.05
Remove fuel filter	C 083.05
Remove distributor housing and fuel line	C 084.05
Remove thermostat housing and temperature inserts	C 206.05
Remove hub from crankshaft	C 035.05
Remove engine mount, free end	C 231.05
Remove wiring	–
Remove oil supply line to crankshaft support bearing, free end	C 184.10

Operations to be performed	See
Remove coolant pipework housing	C 206.05
Remove engine coolant pump	C 202.05
Disconnect leak-off fuel line	C 086.05
Remove wiring harness for injection pumps	Special Publication
Remove injection line and injector	C 075.05
Remove valve drive	C 055.05
Remove pushrod	C 054.05
Remove cylinder head	C 041.05
Remove valve roller tappet	C 054.05
Remove end cover for clamping element	C 075.05
Remove injection pump	C 073.05
Remove fuel temperature sensor	Special Publication
Remove fuel lines in V-chamber	C 084.05
Remove connecting housing, bottom (for intercooler)	C 111.05
Remove oil filter	C 183.05
Remove oil heat exchanger	C 183.05
Remove flywheel	C 032.05
Install crankcase in assembly dolly	–
Remove elbow from gear case to oil pan	C 024.05
Remove oil pan	C 014.05
Remove suction housing	C 181.05
Remove lube oil pump and oil pressure relief valve	C 181.05
Remove gear case cover	C 024.05
Remove axles and idler gears from gear case cover	C 025.05
Remove gear case, free end	C 024.05
Remove flywheel housing	C 021.05
Remove piston with connecting rod	C 037.05
Remove crankshaft	C 031.05
Remove crankshaft gear, driving end	C 022.05
Remove cylinder liner	C 013.05
Remove non-return valve from crankcase, right	C 181.05
Remove crankcase from assembly dolly	–
Remove oil spray nozzle	C 184.10
Remove camshaft	C 051.05
Remove plug and end cover	C 011.05
Remove blanking plug for oil bore and coolant bore	C 011.05
Remove camshaft bearing bush	C 011.05

* – not always applicable (order-specific) –

B 005 Engine Assembly

The sequence in which the following required procedures are listed corresponds to the order in which actual assembly is performed.

The individual tasks are described in detail in the Groups listed in the right-hand column.

Operations to be performed	See
Check crankcase	C 011.05.08
Make sure that oilways are perfectly clean	C 011.05.08
Install end cover and plug	C 011.05.08
Install plug for oil and coolant bores	C 011.05.08
Measure crankcase bore	C 011.05.08
Install camshaft bearing shell	C 011.05.08
Install main bearing cap (without bearing shells)	C 011.05.08
Measurement crankshaft main bearing bore	C 011.05.08
Install oil spray nozzle	C 184.10
Mount crankshaft	C 031.05.08
Install crankshaft	C 031.05
Install crankshaft gear, driving end	C 022.05
Install camshaft	C 051.05
Install non-return valve in crankcase, right	C 181.05
Install crankcase in assembly dolly	–
Install cylinder liner	C 013.05
Measure cylinder liner bore and projection	C 013.05
Install piston with connecting rod	C 037.05
Install flywheel housing	C 021.05
Install gear case, free end	C 024.05
Install axle and idler gear in gear case cover	C 025.05
Install gear case cover	C 024.05
Install lube oil pump and oil pressure relief valve	C 181.05
Install suction housing	C 181.05
Install oil pan	C 014.05
Install elbow from gear case to oil pan	C 024.05
Remove crankcase from assembly dolly	–
Set crankcase on assembly frame	–
Install flywheel	C 032.05
Install oil heat exchanger	C 183.05
Install oil filter	C 183.05
Install engine coolant pump	C 202.05
Install lower connecting housing (for intercooler)	C 111.05
Install fuel lines in Vee chamber	C 084.05
Install fuel temperature sensor	Special Publication
Install fuel injection pump	C 073.05

Operations to be performed	See
Install valve roller tappet	C 054.05
Install cylinder head	C 041.05
Install pushrod	C 054.05
Install valve drive	C 055.05
Adjust valve clearance	C 055.05
Check camshaft timing	C 051.05
Connect leak-off fuel line	C 086.05
Install clamping element end cover	C 075.05
Install injectors and injection line	C 075.05
Install injection pump cable harness	Special Publication
Install coolant control housing	C 206.05
Install oil supply line to crankshaft support bearing, free end	C 184.10
Install sensor in coolant distribution housing	Special Publication
Install engine mount, free end	C 231.05
Install hub on crankshaft	C 035.05
Install thermostat housing and temperature inserts	C 206.05
Install distributor housing and fuel line	C 084.05
Install fuel filter	C 083.05
Install fuel delivery pump and fuel line	C 081.05
Install engine lifting device	C 015.05
Install fuel line	C 082.05/C 084.05
Install exhaust manifold	C 142.05
Install starter	C 172.05
Install air compressor*	C 362.40
Install intercooler	C 111.05
Connect engine coolant line	C 202.10
Install cylinder head cover	C 055.10
Install turbocharger	C 101.01
Install oil return lines for turbochargers	C 185.25
Install oil supply lines to turbochargers	C 185.10
Install vibration damper and belt pulley	C 035.05
Install fan drive carrier, bearing unit and belt tensioner*	C 221.05
Install V-ribbed belt for fan drive and set V-belt tension*	C 028.05
Install generator	C 213.05
Install V-ribbed belt for generator and set V-belt tension	C 028.05
Install sensor in charge air manifold	Special Publication
Install charge air manifold	C 124.05
Install upper connecting housing (intercooler)	C 111.05
Install ECU housing and bracket	Special Publication
Install charge air coolant pump*	–
Install charge air coolant line *	–

Operations to be performed	See
Connect electric cable	–
Install crankcase breather	C 018.10
Install oil dipstick and oil filler pipe	C 182.10
Install monitoring instrument	Special Publication
Pressure-test fuel system	C 080.08
Pressure-test coolant chamber	C 200.08

* – not always applicable (order-specific) –



B 006 Engine Running-In

If pistons, piston rings or cylinder liners have been replaced, the engine must be run in as per the appropriate run-in schedule.

Conscientious running in is of critical importance as regards the durability and operational reliability of the engine. Use a dynamometer or generator to absorb the power developed in the braking run.

Power must be transmitted from the engine to the load by means of a resilient coupling.

Settings

Set intake temperatures before engine in accordance with the temperatures stated for the engine in its MTU Engine Acceptance Test Record.

The engine coolant temperature depends on the operating range of the coolant thermostat.

Record readings for power, fuel, lube oil, coolant, charge air and control air at each test point (time, speed and effective power) of the run-in schedule and enter readings under "Engine Run-in" in "MTU Diesel Engine Factory Test" record.

Operations to be performed	See
Install engine in test bed	–
Connect engine to dynamometer or generator	–
Connect intake air, exhaust, engine coolant, raw water and fuel pipework.	–
Connect charge air coolant line*	–
Connect oil pressure line and oil temperature measurement feeler	–
Connect crankcase ventilation line	–
Connect all measuring hoses and cables	–
Connect dialogue unit to ECU	–
Fill expansion tank with coolant and 2 % corrosion inhibitor oil up to max. mark	Operating Instructions
Check that fuel in service or supply tank is to specification	MTU Fluids and Lubricants Specification
Fill oil system up to max. mark with fresh oil	Operating Instructions
Check operation of engine governor and governor actuator before starting engine	–
Check operation of emergency shutdown system	–
Start engine via ECS	Operating Instructions
After operating engine at no-load for approx. 1 min, shut down engine, check oil level, remove valve gear cover, check valve gear lubrication	–
Start engine, check idling speed	–
Check for leaks at coolant, oil and fuel lines, crankcase seals, air system and exhaust lines	Operating Instructions
Run in engine and record measurements in accordance with running-in schedule	MTU Engine Acceptance Test Record
Check engine speed and brake load	–
Compare/check injection, temperatures, pressures and speeds at gauge dialogue units with Acceptance Test Record	–
Check lube oil temperature before engine	–
Measure intake depression before exhaust turbocharger	–
Measure exhaust gas temperature after turbocharger	–

Operations to be performed	See
Check exhaust backpressure after engine	–
Check colour of exhaust gas	–
Enter barometric reading and relative humidity in record	MTU Engine Acceptance Test Record
Check engine for abnormal noises and for leaks	–
Check/ correct speed-sensitive fuel limiter curve, no-load and full-load positions	–
Check oil filter (at time specified in run-in sequence)	Operating Instructions
After running in, perform factory test run in accordance with MTU Acceptance Test Record	–
Enter operational values in enclosed Factory Test Record	MTU Engine Acceptance Test Record
Compare measured values with values in Acceptance Test Record	MTU Engine Acceptance Test Record
Shut down engine	Operating Instructions
Preserve engine if it is to be stored for a prolonged period	Operating Instructions
Adopt suitable protective measures if engine is scheduled for marine transport	–
Remove engine from test bed	–
Spray engine with protective paint	–

* – only for TB version –

Running-In Schedule (test stand) 8V2000C

8V2000 JWCC (TC)

DDC-Model R0837K33, MTU-Model C10 – 575 BHP (429 kW) 2100 RPM

Running time	Speed	Power	Power	Torque	Torque	Remarks
t [min]	n _{Mot} [min ⁻¹]	P [kW]	P [HP]	M [Nm]	M [ft × lb]	
10	1100	53	71	461	340	Engine check (visual inspection)
8.5	1350	88	118	624	460	
10	2090	343	460	1573	1160	
5	Idling	Minimum	Minimum	Minimum	Minimum	Engine check (visual inspection)
5	2100	429	575	1950	1438	
5	2100	429	575	1950	1438	
5	2100	429	575	1950	1438	
1.5	Idling	Minimum	Minimum	Minimum	Minimum	

DDC-Model R0837K33, MTU-Model C30/E30 – 525 BHP (392 kW) 2100 RPM

Running time	Speed	Power	Power	Torque	Torque	Remarks
t [min]	n _{Mot} [min ⁻¹]	P [kW]	P [HP]	M [Nm]	M [ft × lb]	
10	1100	53	71	461	340	Engine check (visual inspection)
8.5	1350	88	118	624	460	
10	2090	312	418	1424	1050	
5	Idling	Minimum	Minimum	Minimum	Minimum	Engine check (visual inspection)
5	2100	392	525	1781	1313	
5	2100	392	525	1781	1313	
5	2100	392	525	1781	1313	
1.5	Idling	Minimum	Minimum	Minimum	Minimum	

DDC-Model R0837K33, MTU-Model C60 – 525 BHP (392 kW) 1800 RPM

Running time	Speed	Power	Power	Torque	Torque	Remarks
t [min]	n _{Mot} [min ⁻¹]	P [kW]	P [HP]	M [Nm]	M [ft × lb]	
10	1100	53	71	461	340	Engine check (visual inspection)
8.5	1350	88	118	624	460	
10	1790	312	418	1661	1225	
5	Idling	Minimum	Minimum	Minimum	Minimum	Engine check (visual inspection)
5	1800	392	525	2205	2076	
5	1800	392	525	2205	2076	
5	1800	392	525	2205	2076	
1.5	Idling	Minimum	Minimum	Minimum	Minimum	

8V2000 JWCC (TC)

DDC-Model R0837K33, MTU-Model C70 – 575 BHP (429 kW) 1800 RPM

Running time	Speed	Power	Power	Torque	Torque	Remarks
t [min]	n_{Mot} [min ⁻¹]	P [kW]	P [HP]	M [Nm]	M [ft × lb]	
10	1100	53	71	461	340	Engine check (visual inspection)
8.5	1350	88	118	624	460	
10	1790	341	457	1820	1342	
5	Idling	Minimum	Minimum	Minimum	Minimum	Engine check (visual inspection)
5	1800	429	575	2276	1678	
5	1800	429	575	2276	1678	
5	1800	429	575	2276	1678	
1.5	Idling	Minimum	Minimum	Minimum	Minimum	

8V2000 SCCC (TB)

DDC-Model R0837K37 MTU-Model C20 – 650 BHP (485 kW) 2100 RPM

Running time	Speed	Power	Power	Torque	Torque	Remarks
t [min]	n _{Mot} [min ⁻¹]	P [kW]	P [HP]	M [Nm]	M [ft × lb]	
10	1100	53	71	461	340	Engine check (visual inspection)
8.5	1350	88	118	624	460	
10	2090	385	517	1763	1300	
5	Idling	Minimum	Minimum	Minimum	Minimum	Engine check (visual inspection)
5	2100	485	650	2205	1626	
5	2100	485	650	2205	1626	
5	2100	485	650	2205	1626	
1,5	Idling	Minimum	Minimum	Minimum	Minimum	

DDC-Model R0837K37 MTU-Model C40 – 605 BHP (485 kW) 2100 RPM

Running time	Speed	Power	Power	Torque	Torque	Remarks
t [min]	n _{Mot} [min ⁻¹]	P [kW]	P [HP]	M [Nm]	M [ft × lb]	
10	1100	53	71	461	340	Engine check (visual inspection)
8.5	1350	88	118	624	460	
10	2090	361	484	1642	1211	
5	Idling	Minimum	Minimum	Minimum	Minimum	Engine check (visual inspection)
5	2100	485	650	2052	1513	
5	2100	485	650	2052	1513	
5	2100	485	650	2052	1513	
1,5	Idling	Minimum	Minimum	Minimum	Minimum	

DDC-Model R0837K37 MTU-Model C60 – 650 BHP (485 kW) 1800 RPM

Running time	Speed	Power	Power	Torque	Torque	Remarks
t [min]	n _{Mot} [min ⁻¹]	P [kW]	P [HP]	M [Nm]	M [ft × lb]	
10	1100	53	71	461	340	Engine check (visual inspection)
8.5	1350	88	118	624	460	
10	1790	388	520	2058	1517	
5	Idling	Minimum	Minimum	Minimum	Minimum	Engine check (visual inspection)
5	1800	485	650	2573	1897	
5	1800	485	650	2573	1897	
5	1800	485	650	2573	1897	
1.5	Idling	Minimum	Minimum	Minimum	Minimum	

8V2000 SCCC (TB)

DDC-Model R0837K37 MTU-Model C80 – 605 BHP (451 kW) 1800 RPM

Running time	Speed	Power	Power	Torque	Torque	Remarks
t [min]	n _{Mot} [min ⁻¹]	P [kW]	P [HP]	M [Nm]	M [ft × lb]	
10	1100	53	71	461	340	Engine check (visual inspection)
8.5	1350	88	118	624	460	
10	1790	361	484	1915	1412	
5	Idling	Minimum	Minimum	Minimum	Minimum	Engine check (visual inspection)
5	1800	451	605	2394	1765	
5	1800	451	605	2394	1765	
5	1800	451	605	2394	1765	
1,5	Idling	Minimum	Minimum	Minimum	Minimum	



1) Abnahmeprüfprotokoll
MTU-Dieselmotor

2) Typ _____

3) Nr. _____

4) Auftrag _____

5) Leistungsberechnung
 $P_y = F \cdot n \cdot K$
 $P_r = \frac{P_y}{\eta}$
 $K = \dots$

6) Kraftstoff
 10) Betriebsleistung _____ kW
 15) Größte Nutzleistung _____ kW bei _____ /min

7) Dichte bei 15°C _____ g/cm³
 8) Heizwert _____ kJ/kg

9) Schmieröl
 20) Luftdruck _____ mbar
 21) Rel. Luftfeuchtigkeit _____ %
 22) Drehsinn ISO1204 _____
 23) Förderbeginn der EP _____ °VOT

Uhrzeit	Drehzahl	Be- lastung		Kraftstoff			Schmieröl			Kühlmittel			Aufladung			Abgas				
		F	N	Menge	Temp	Stopptzeit	Dichte	Verbrauch	spezifisch	Druck	Temperatur	Druck	Temperatur	Druck	Temperatur	Druck	Temperatur	Druck	Temperatur	
h	1/min	kW	kW	dm ³	°C	s	g/cm ³	kg/h	g/(kW·h)	bar	°C	bar	°C	bar	°C	bar	°C	mm H ₂ O	°C	
30	31	32	33	34	35	36	37	38	39	40	41	42	43	44	45	46	47	48	49	50

Uhrzeit	Drehzahl	Be- lastung		Kraftstoff			Schmieröl			Kühlmittel			Aufladung			Abgas				
		F	N	Menge	Temp	Stopptzeit	Dichte	Verbrauch	spezifisch	Druck	Temperatur	Druck	Temperatur	Druck	Temperatur	Druck	Temperatur	Druck	Temperatur	
h	1/min	kW	kW	dm ³	°C	s	g/cm ³	kg/h	g/(kW·h)	bar	°C	bar	°C	bar	°C	bar	°C	mm H ₂ O	°C	

- 1 Inspector report / Informe de inspección / Procès-verbal de réception
- 2 Model / Tipo
- 3 Engine serial No. / Número de serie del motor / Motor No.
- 4 Order No. / Nº de comando
- 5 Serial No. / Número de serie / Número de identificación
- 6 Fuel / Combustible
- 7 Specific gravity / Densité
- 8 Caloric value / Valeur calorifique / Poder calorífico altitudinal
- 9 Lub oil / Huile de graissage
- 10 Service power / Puissance utile max.
- 11 Max. effective power / Puissance effective max.
- 12 Relative humidity / Humidité relative de l'air
- 13 Relative humidity / Humidité relative de l'air
- 14 Relative humidity / Humidité relative de l'air
- 15 Max. effective power / Puissance utile max.
- 16 Relative humidity / Humidité relative de l'air
- 17 Relative humidity / Humidité relative de l'air
- 18 Relative humidity / Humidité relative de l'air
- 19 Relative humidity / Humidité relative de l'air
- 20 Barometric pressure / Pression barométrique
- 21 Relative humidity / Humidité relative de l'air
- 22 Relative humidity / Humidité relative de l'air
- 23 Start of fuel delivery / Début de refroidement pompe
- 24 Page / Page
- 25 Date / Date
- 26 Test bed / Banc d'essai
- 27 Revolving / Ventilator
- 30 Time / Heure
- 31 Speed / Régime
- 32 Brake test / Effort dynamométrique
- 33 Brake power, test stand / Puissance à l'essai
- 34 Brake power, standard conditions / Puissance au régime, conditions normalisées
- 35 Quantity of fuel / Quantité de combustible
- 36 Combustible, temperature / Combustible, température
- 37 Fuel flow measurement / Mesure du débit de combustible
- 38 Fuel specific gravity / Combustible, densité
- 39 Fuel consumption / Consommation
- 40 Specific fuel consumption / Consommation spécifique de combustible
- 41 Fuel rack setting / Débit de combustible
- 42 Lub oil pressure before filter / Huile de graissage, pression avant filtre
- 43 Lub oil pressure before engine / Huile de graissage, pression avant moteur
- 44 Lub oil pressure before engine / Huile de graissage, pression avant moteur
- 45 Lub oil pressure before engine / Huile de graissage, pression avant moteur
- 46 Lub oil pressure before engine / Huile de graissage, pression avant moteur
- 47 Lub oil pressure before engine / Huile de graissage, pression avant moteur
- 48 Lub oil pressure before engine / Huile de graissage, pression avant moteur
- 49 Lub oil pressure before engine / Huile de graissage, pression avant moteur
- 50 Lub oil pressure before engine / Huile de graissage, pression avant moteur
- 51 Lub oil pressure before engine / Huile de graissage, pression avant moteur
- 52 Lub oil pressure before engine / Huile de graissage, pression avant moteur
- 53 Lub oil pressure before engine / Huile de graissage, pression avant moteur
- 54 Lub oil pressure before engine / Huile de graissage, pression avant moteur
- 55 Lub oil pressure before engine / Huile de graissage, pression avant moteur
- 56 Lub oil pressure before engine / Huile de graissage, pression avant moteur
- 57 Lub oil pressure before engine / Huile de graissage, pression avant moteur
- 58 Lub oil pressure before engine / Huile de graissage, pression avant moteur
- 59 Lub oil pressure before engine / Huile de graissage, pression avant moteur
- 60 Lub oil pressure before engine / Huile de graissage, pression avant moteur
- 61 Lub oil pressure before engine / Huile de graissage, pression avant moteur
- 62 Lub oil pressure before engine / Huile de graissage, pression avant moteur
- 63 Lub oil pressure before engine / Huile de graissage, pression avant moteur
- 64 Lub oil pressure before engine / Huile de graissage, pression avant moteur
- 65 Lub oil pressure before engine / Huile de graissage, pression avant moteur
- 66 Lub oil pressure before engine / Huile de graissage, pression avant moteur
- 67 Lub oil pressure before engine / Huile de graissage, pression avant moteur
- 68 Lub oil pressure before engine / Huile de graissage, pression avant moteur
- 69 Lub oil pressure before engine / Huile de graissage, pression avant moteur
- 70 Lub oil pressure before engine / Huile de graissage, pression avant moteur
- 71 Lub oil pressure before engine / Huile de graissage, pression avant moteur
- 72 Lub oil pressure before engine / Huile de graissage, pression avant moteur
- 73 Lub oil pressure before engine / Huile de graissage, pression avant moteur
- 74 Lub oil pressure before engine / Huile de graissage, pression avant moteur
- 75 Lub oil pressure before engine / Huile de graissage, pression avant moteur
- 76 Lub oil pressure before engine / Huile de graissage, pression avant moteur
- 77 Lub oil pressure before engine / Huile de graissage, pression avant moteur
- 78 Lub oil pressure before engine / Huile de graissage, pression avant moteur
- 79 Lub oil pressure before engine / Huile de graissage, pression avant moteur
- 80 Lub oil pressure before engine / Huile de graissage, pression avant moteur
- 81 Lub oil pressure before engine / Huile de graissage, pression avant moteur
- 82 Lub oil pressure before engine / Huile de graissage, pression avant moteur
- 83 Lub oil pressure before engine / Huile de graissage, pression avant moteur
- 84 Lub oil pressure before engine / Huile de graissage, pression avant moteur
- 85 Lub oil pressure before engine / Huile de graissage, pression avant moteur
- 86 Lub oil pressure before engine / Huile de graissage, pression avant moteur
- 87 Lub oil pressure before engine / Huile de graissage, pression avant moteur
- 88 Lub oil pressure before engine / Huile de graissage, pression avant moteur
- 89 Lub oil pressure before engine / Huile de graissage, pression avant moteur
- 90 Lub oil pressure before engine / Huile de graissage, pression avant moteur

MTU Motoren- und Turbinen-Union
 Friedrichshafen GmbH
 88040 Friedrichshafen · Telefon (075 41) 90-0
 Telex 7 34 280-0 mit d · Telefax (075 41) 90 81 08

- 1 Inspection report
Procès-verbal de réception
Protocolo de recepción
- 2 Model
Type
Tipo
- 3 Engine serial No.
N° du moteur
Motor N°
- 4 Order No.
N° de commande
Pedido N°
- 5 Power calculation
Calcul de la puissance au frein
Cálculo de la potencia al freno
- 6 Fuel
Combustible
Combustible
- 7 Specific gravity
Densité
Densidad
- 8 Calorific value
Valeur calorifique inférieure
Poder calorífico inferior
- 9 Lube oil
Huile de graissage
Aceite de lubricación
- 10 Service power
Puissance de service
Potencia de servicio
- 15 Max. effective power
Puissance utile maxi.
Potencia efectiva mayor
- 16 Altitude above sea level
Altitude
Altura sobre nivel de mar
- 17 Intake air temperature
Air aspiré, température
Aire de aspiración, temperatura
- 18 Relative humidity
Humidité relative de l'air
Humedad relativa del aire
- 20 Barometric pressure
Cote barométrique
Presión barométrica
- 21 Relative humidity
Humidité relative de l'air
Humedad relativa del aire
- 22 Direction of rotation
Sens de rotation
Sentido de giro
- 23 Start of fuel delivery
Début de refoulement pompe
d'injection
Comienzo de suministro
bomba de inyección
- 24 Page 25 Date
Page Date
Página Fecha
- 26 Test bed
Banc d'essai
Banco de pruebas
- 27 Recorded by
Contrôleur
Verificador
- 30 Time 31 Speed
Heure Régime
Hora Revoluciones
- 32 Brake load
Effort dynamométrique
Carga del freno
- 33 Brake power, test stand
Puissance au frein, banc d'essais
Potencia al freno, banco de pruebas
- 34 Brake power, standard conditions
Puissance au frein, conditions
normalisées
Potencia al freno, condiciones
normalizadas
- 35 Quantity of fuel
Quantité de combustible
Cantidad de combustible
- 36 Fuel temperature
Combustible, température
Combustible, temperatura
- 37 Fuel flow measurement
Mesure du flux de combustible
Medición caudal de combustible
- 38 Fuel specific gravity
Combustible, densité
Combustible, densidad
- 39 Fuel consumption
Combustible, consommation
Combustible, consumo
- 40 Specific fuel consumption
Combustible, consommation
spécifique
Consumo específico de
combustible
- 41 Fuel rack setting
Débit de combustible
Llenado de combustible
- 42 Lube oil pressure before filter
Huile de graissage, pression avant
filtre
Aceite de lubricación,
presión antes del filtro
- 43 Lube oil pressure before engine
Huile de graissage, pression avant
moteur

- Aceite de lubricación, presión antes del motor
- 45 Lube oil pressure in supercharger coupling or before turbocharger
Huile de graissage, pression dans l'accouplement du compresseur, resp. avant le turbocompresseur à gaz d'échappement
Aceite de lubricación, presión en el acoplamiento del turbo resp. antes del turbosobrealimentador por gases de escape
- 46 Lube oil pressure, measuring block / Last bearing
Dernier palier / Réglette de mesure
Ultimo cojinete/Regleta de medición
- 47 Lube oil temperature before engine
Huile de graissage, température avant moteur
Aceite de lubricación, temperatura antes del motor
- 48 Lube oil temperature after engine
Huile de graissage, température après moteur
Aceite de lubricación, temperatura después del motor
- 50 Coolant temperature before engine
Agent de refroidissement, température avant moteur
Agente refrigerante, temperatura antes del motor
- 51 Coolant temperature after engine
Agent de refroidissement, température après moteur
Agente refrigerante, temperatura después del motor
- 52 Coolant pressure before pump
Agent de refroidissement, pression avant pompe
Agente refrigerante, presión antes de la bomba
- 53 Coolant pressure after pump
Agent de refroidissement, pression après pompe
Agente refrigerante, presión después de la bomba
- 50 Coolant pressure after engine
Agent de refroidissement, pression après moteur
Agente refrigerante, presión después del motor
- 55 Charge air temperature before engine
Suralimentation, température de l'air avant moteur
Sobrealimentación, temperatura del aire antes del motor
- 58 Charge air temperature before cylinder
Suralimentation, température l'air avant cylindre
Sobrealimentación, temperatura del aire antes de los cilindros
- 59 Charge air pressure before engine
Suralimentation, pression de l'air avant moteur
Sobrealimentación, presión del aire antes del motor
- 60 Charge air pressure before cylinder
Suralimentation, pression de l'air entrée cylindre
Sobrealimentación, presión del aire ante cilindro
- 64 Exhaust temperature after engine
Gaz d'échappement, température après moteur
Gases de escape, temperatura después del motor
- 65 Exhaust pressure after engine
Gaz d'échappement, pression après moteur
Gases de escape, presión después del motor
- 66 Smoke index
Gaz d'échappement, noircissement
Gases de escape, ennegrecimiento
- 72 Fuel temperature before engine
Combustible, température avant moteur
Temperatura combustible antes del motor
- 80 Lube oil consumption
Consommation d'huile de graissage
Consumo aceite de lubricación
- 82 Electric starter motor
Démarreur électrique
Arrancador eléctrico
- 86 Remarks
Observations
Observaciones
- 87 No faults or deficiencies occurred during the acceptance test
Autant qu'on pût voir, des vices n'ont pas été détectés au cours de la marche de recette ci-dessus
Durante la susodicha marcha de recepción no se han presentado deficiencias algunas, según lo observado en la misma
- 88 For MTU
Pour MTU
Para MTU
- 89 For the purchaser
Pour l'acheteur
Para el comprador



5) Leistungsberechnung

$$P_y = F \cdot n \cdot K$$

$$P_r \triangleq \dots$$

$$K = \dots$$

6) Kraftstoff

7) Dichte bei 15° C g/cm³

8) Heizwert kJ/kg

9) Schmieröl

10) Betriebsl

15) GröBte N kW

Uhrzeit	Drehzahl	Belastung	Bremsleistung		Kraftstoff				
			Prüfstand	unter Normbedingungen	Menge	Temp.	Stoppzeit	Dichte	Verbr.
	n	F	P _y	P _r	V	t	ρ	B	
h min	1/min	N	kW	kW	dm ³	° C	s	g/cm ³	kg/h
30	31	32	33	34	35	36	37	38	39
1									
2									
3									
4									
5									
6									
7									
8									
9									
10									
11									
12									
13									
14									
15									
16									
17									
18									
19									
20									
21									
22									
23									
24									
25									
26									
27									
28									
29									
30									

80) Schmierölverbrauch = kg/h

bei P_y = kW, n = 1/min

82) Elektrischer Anlasser

86) Bemerkungen

V-424-9506

B 007 Engine Installation and Operation

Operations to be performed	See
Open all connections, remove cover and rubber plugs	–
Attach engine only on suspension brackets provided as shown in installation drawing, taking centre of gravity and transportation specifications into consideration, and install in plant.	–
Join connections appropriately	–
Fill engine coolant system	Operating Instructions
Fill charge air coolant system*	–
Fill oil system with engine oil	Operating Instructions
Prepare engine for operation	Operating Instructions
Start engine	Operating Instructions
Perform checks while engine is running	Operating Instructions
Carry out test run	Operating Instructions
Shut down engine	Operating Instructions
Perform after-shutdown services	Operating Instructions
Preservation measures are required if an extended out-of-service period is intended	Operating Instructions

* – only for TB version –



B 008 Engine Drawings

Engine cross-section

Engine longitudinal section

Engine layout, driving end

Engine layout, free end

Engine side view, left

Engine side view, right

Engine overhead view

Engine cross-section

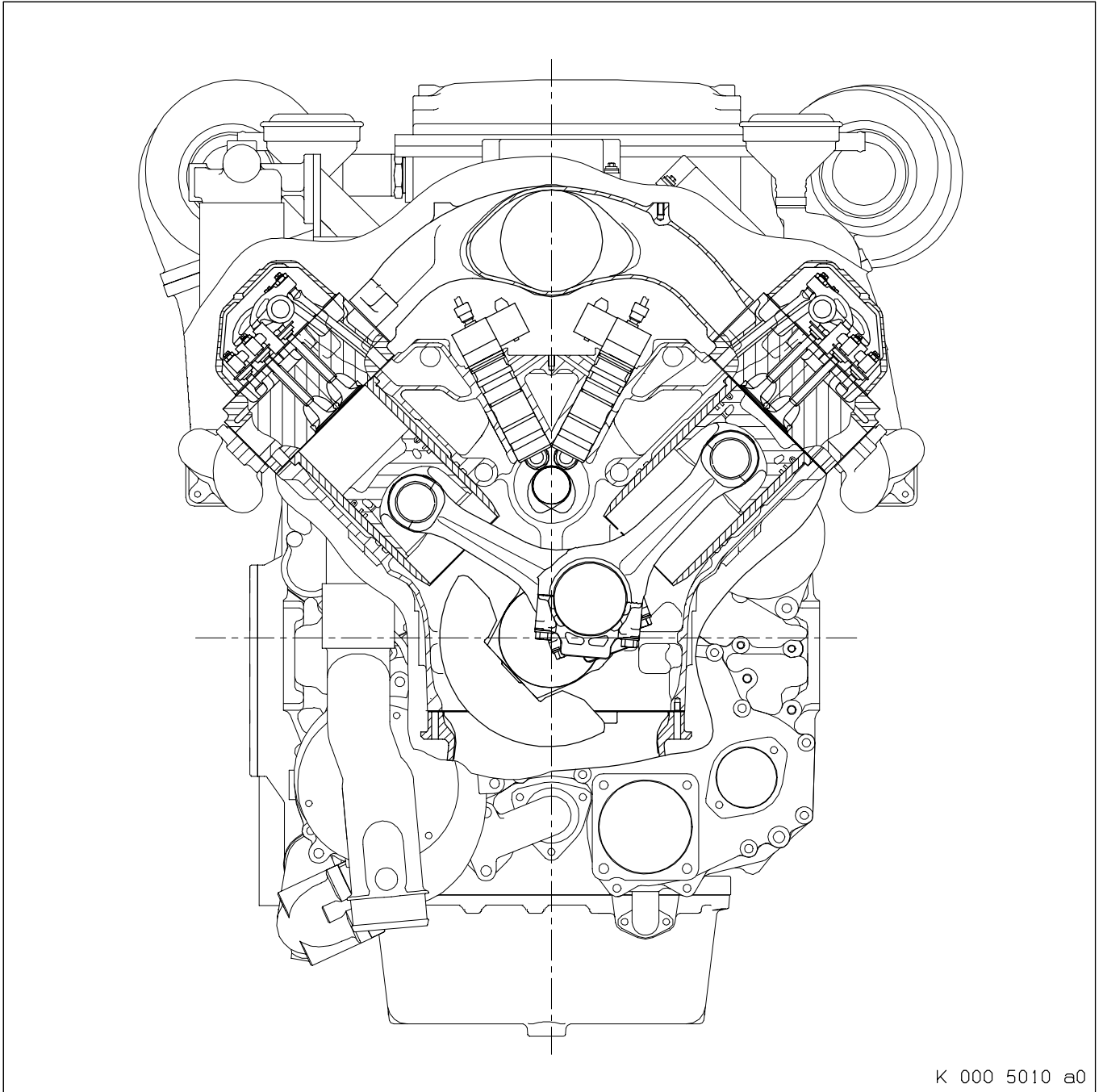

Engine longitudinal section

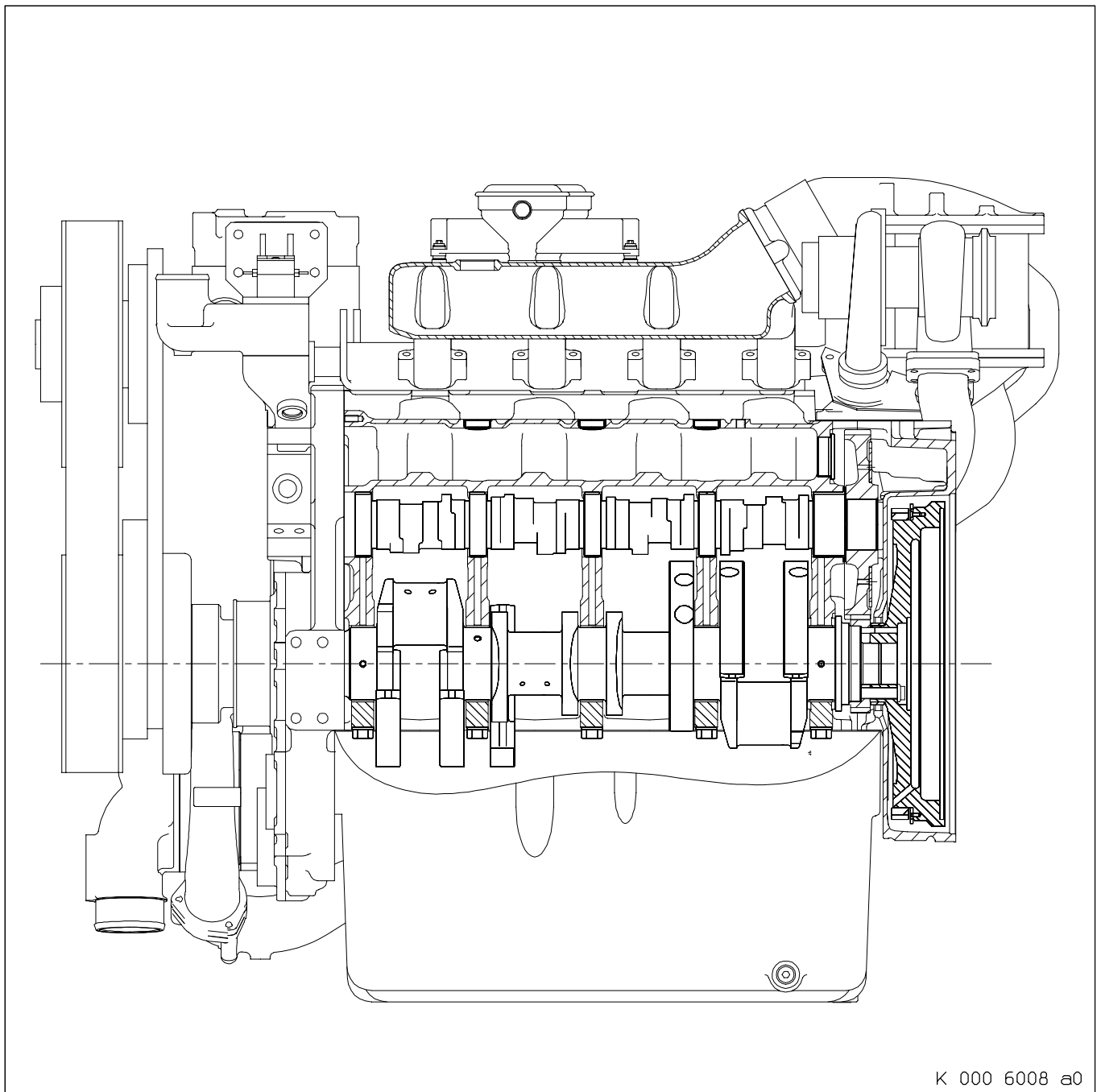

Engine layout, driving end

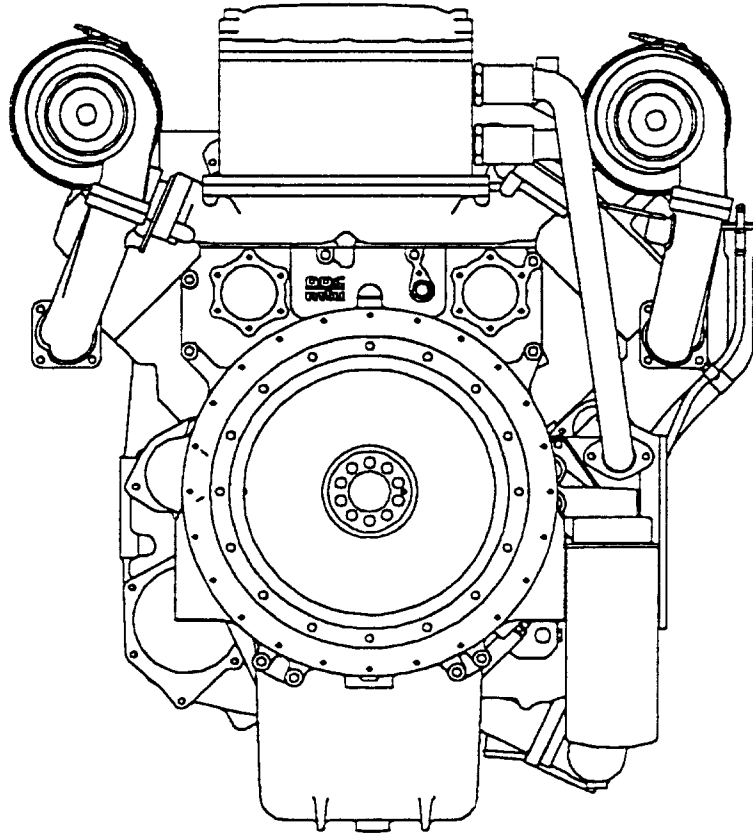

F 000 0029 a0

Engine layout, free end

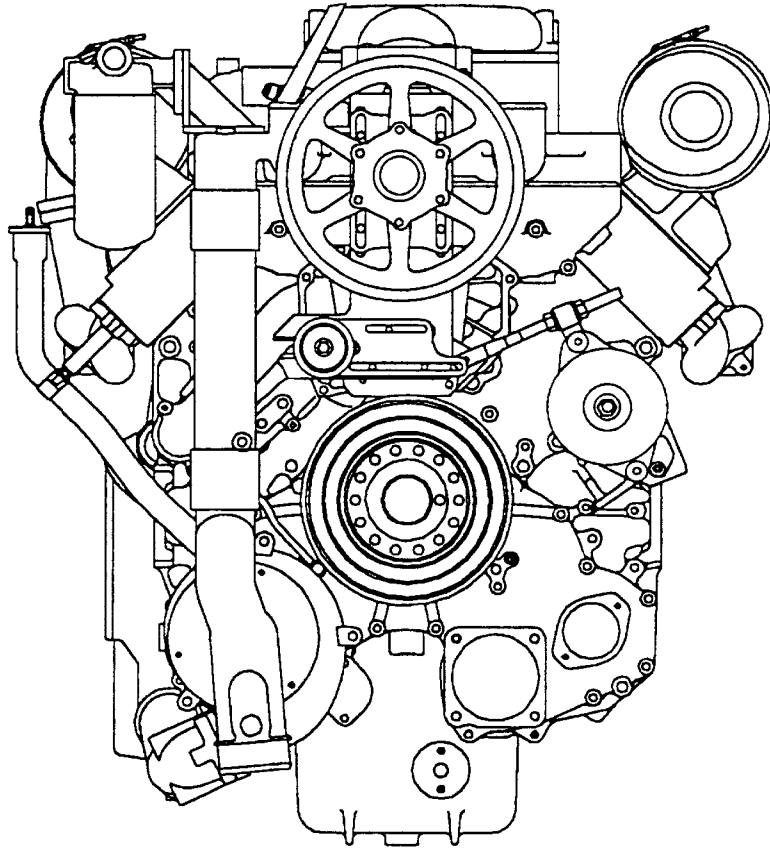

F 000 0025 a0

Engine side view, left

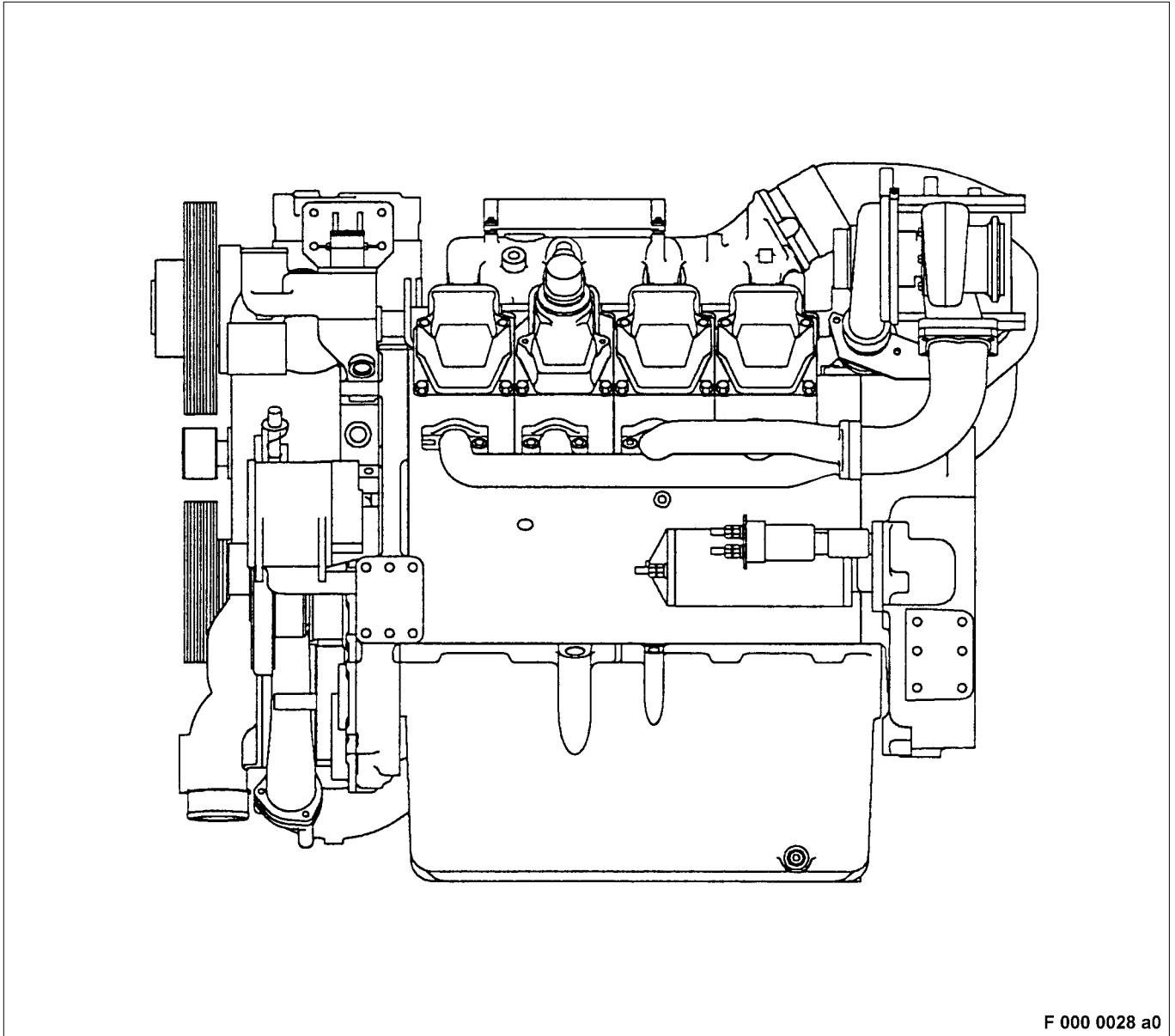

Engine side view, right

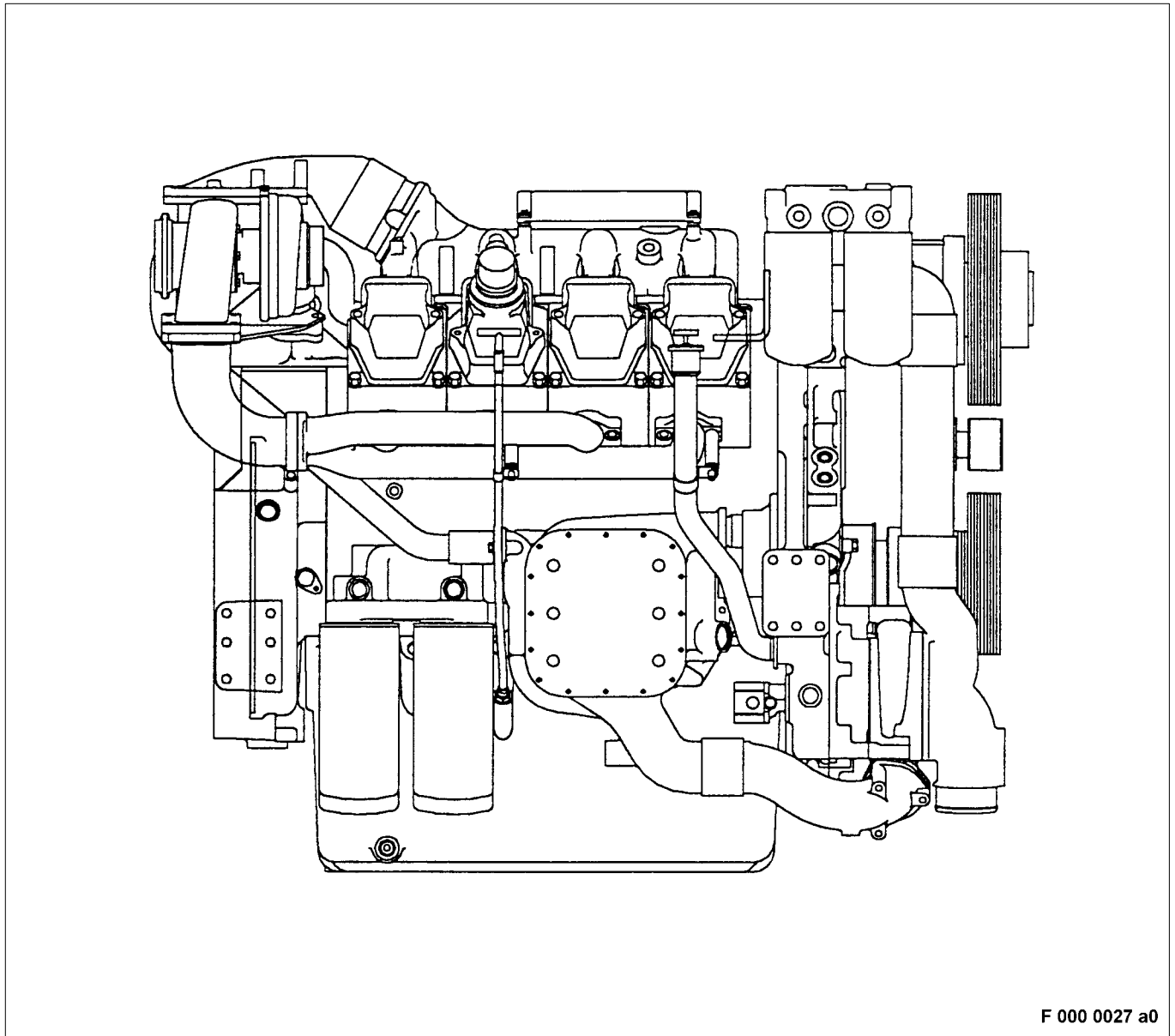

F 000 0027 a0

Engine overhead view

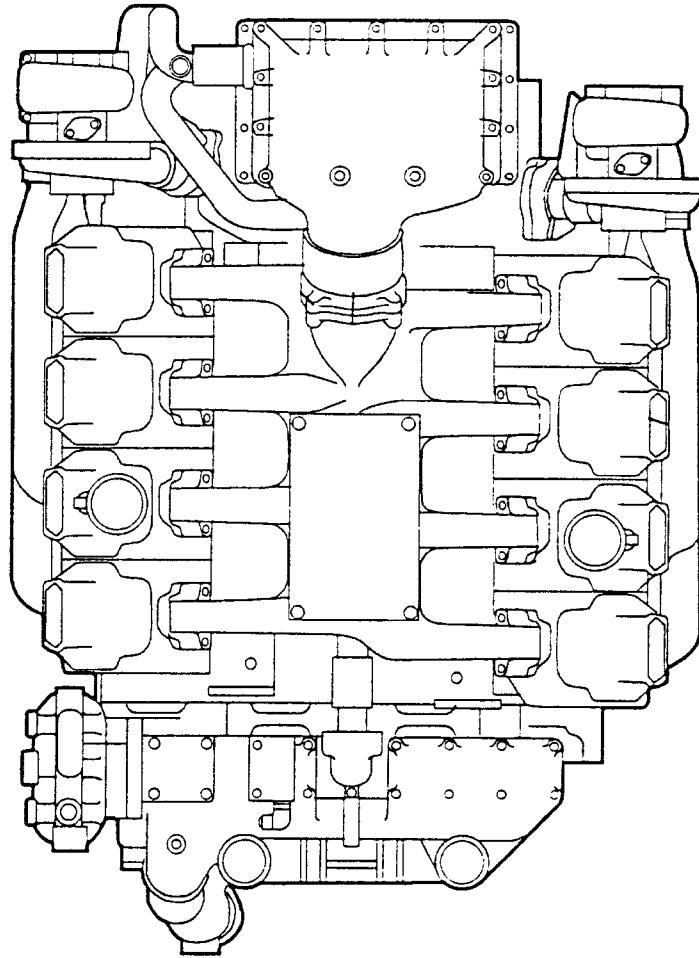

F 000 0026 a0

C Group Survey

- 010 Crankcase and Externally Mounted Components**
- 020 Gear Train**
- 030 Running Gear**
- 040 Cylinder Head**
- 050 Valve Gear**
- 060 Governor Actuator ***
- 070 Fuel System – High-Pressure**
- 080 Fuel System – Low Pressure**
- 090 Regulation***
- 100 Exhaust Turbocharger**
- 110 Charge Air Cooling**
- 120 Air Intake/Air Supply**
- 130 – not assigned –**
- 140 Exhaust System**
- 150 – not assigned –**
- 160 – not assigned –**
- 170 Starting System**
- 180 Lube Oil System**
- 190 – not assigned –**
- 200 Cooling System**
- 210 Power Supply, Engine Side**
- 220 Cooling Air System**
- 230 Mounting/Support**
- 240 Engine-Gearbox Connection***
- 250 PTO Systems, Driving End and Free End (Coupling)**
- 290 Pumps Driven Separately***
 - Blank Register**
- 360 Auxiliary Systems, Supplementary Units**
 - Blank Register**
- 500 Monitoring, Control and Regulation Devices**

* not mounted on this engine

C Group Survey

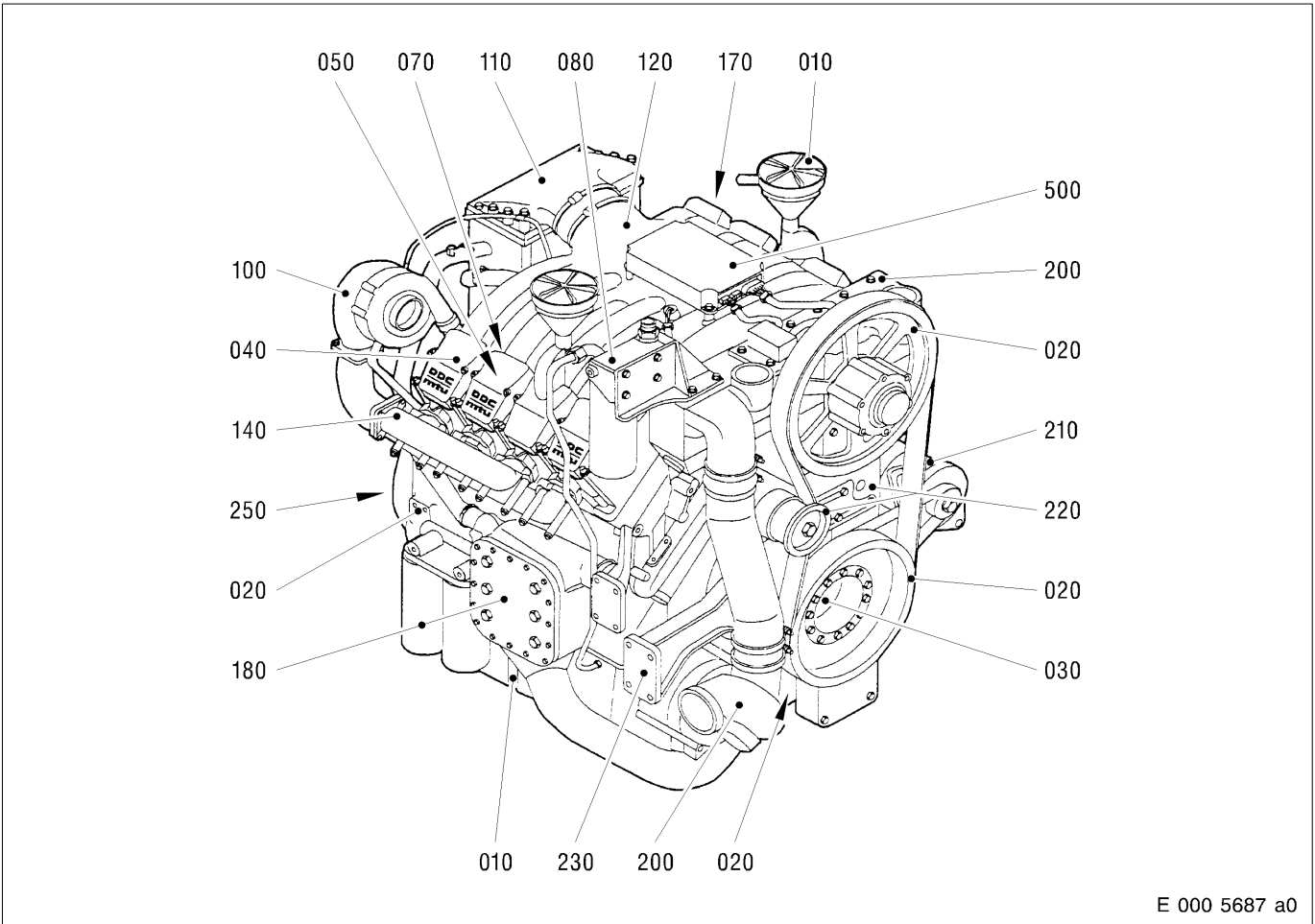

E 000 5687 a0

- | | | | |
|------------|--|------------|---|
| 010 | Crankcase and Externally Mounted Components | 140 | Exhaust System |
| 020 | Gear Train | 170 | Starting System |
| 030 | Running Gear | 180 | Lube Oil System |
| 040 | Cylinder Head | 200 | Cooling System |
| 050 | Valve Gear | 210 | Power Supply, Engine Side |
| 070 | Fuel System – High-Pressure | 220 | Cooling Air System |
| 080 | Fuel System – Low Pressure | 230 | Mounting/Support |
| 100 | Exhaust Turbocharger | 250 | PTO Systems, Driving End and Free End (Coupling) |
| 110 | Charge Air Cooling | 360 | Auxiliary Systems, Supplementary Units |
| 120 | Air Intake/Air Supply | 500 | Monitoring, Control and Regulating Equipment |

Contents

C 010	Crankcase and Externally Mounted Components
C 011.05	Crankcase
C 011.05.01	General view
C 011.05.02	Special tool
C 011.05.04	Before-removal operations
C 011.05.08	Inspection and repair
C 011.05.12	After installation operations
C 013.05	Cylinder liner
C 013.05.01	General view
C 013.05.02	Special tool
C 013.05.04	Before-removal operations
C 013.05.05	Removal
C 013.05.08	Inspection and repair
C 013.05.11	Installation
C 013.05.12	After installation operations
C 014.05	Oil pan
C 014.05.01	General view
C 014.05.04	Before-removal operations
C 014.05.05	Removal
C 014.05.08	Inspection and repair
C 014.05.11	Installation
C 014.05.12	After installation operations
C 015.05	Lifting attachments for engine and running gear
C 015.05.01	General view
C 015.05.04	Before-removal operations
C 015.05.05	Removal
C 015.05.08	Inspection and repair
C 015.05.11	Installation
C 015.05.12	After installation operations
C 018.10	Crankcase ventilation
C 018.10.01	General view
C 018.10.04	Before-removal operations
C 018.10.05	Removal
C 018.10.08	Inspection and repair
C 018.10.11	Installation
C 018.10.12	After installation operations

C 010 Crankcase and Externally Mounted Components

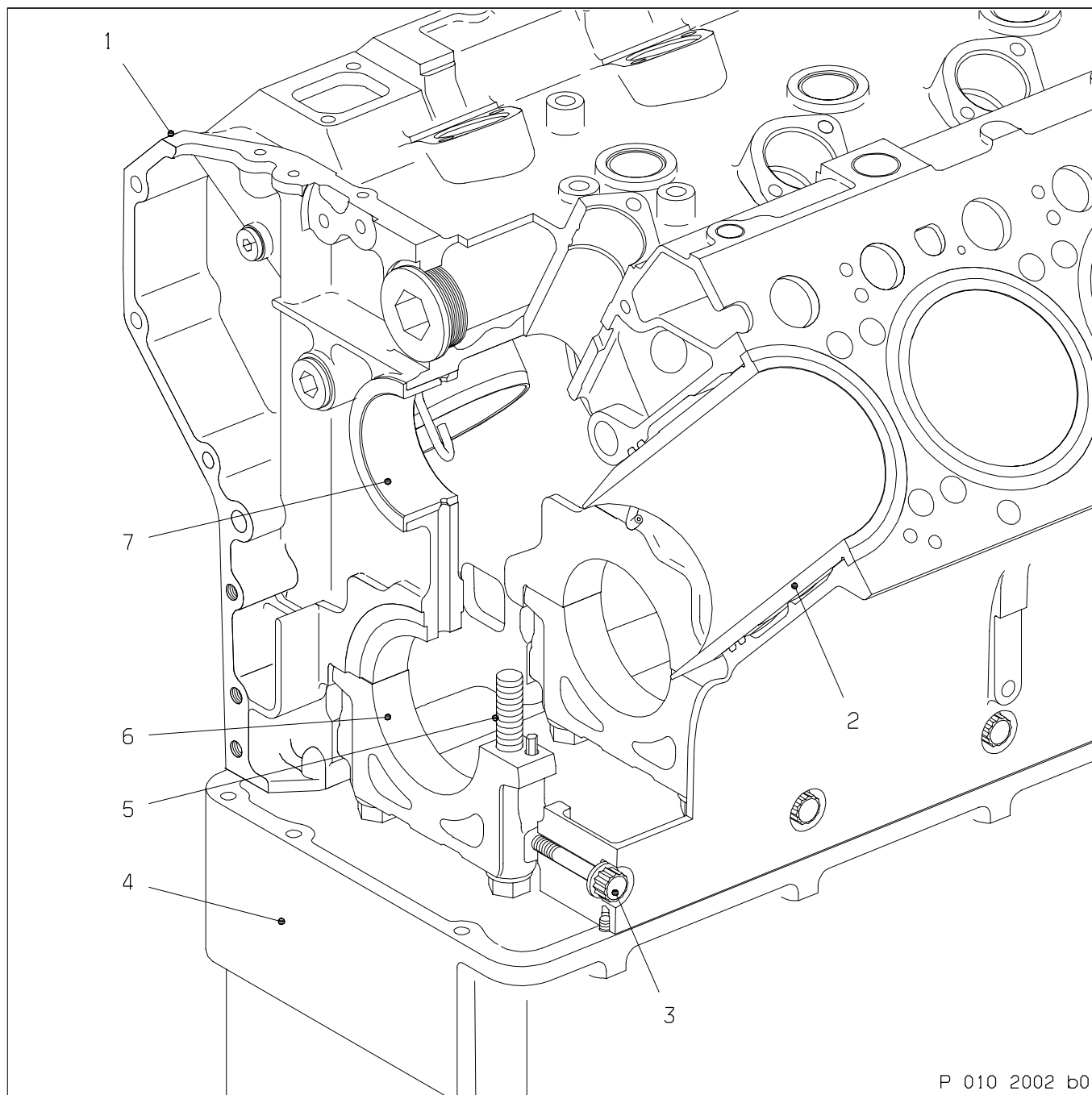

P 010 2002 b0

- | | |
|--------------------|--------------------------------------|
| 1 Crankcase | 5 Hex screw |
| 2 Cylinder liner | 6 Crankshaft alignment bearing cover |
| 3 Double-hex screw | 7 Camshaft bearing |
| 4 Oil pan | |

The following is a list of auxiliary equipment and materials needed for the assembly operations:

!	CAUTION
<p>When using these chemical substances, it is essential to observe the manufacturer's instructions for use, safety instructions and waste disposal specifications.</p>	

Materials and consumables	Designation	Order No.		Remarks
		MTU	DDC	
Emery cloth				
Wire brush				
Bottle brush				
Magnifying glass				
Spray gun				
Inspection lamp				
Endoscope with cold light				
Liquid nitrogen				
Activator	Loctite No. 7649	50548		
Vaseline	Petroleum jelly, white	40317		
Thread-locking compound	Loctite no. 270	40083		Final strength at 20 °C ≈ 12 h
Sealing paste	Elastosil N 189	50545		
Engine oil				
Multipurpose grease	Shell Retinax	40333		
Corrosion preventive	Pfinder AP 11 F	40355		
Cleaning agent	Solvclean KW	40022		
Cleaning agent (carbon-deposit remover)	Meister Proper	40377		
Kerosene or diesel fuel				
Denaturated ethanol		40250		
Engineer's blue	blue	40641		
Dry compressed air				
Corrosion preventive	Caramba Express	40008		
Magnetic crack-testing equipment with fluorescent magnetic powder				
Surface crack-testing equipment with red penetrant dye				
Surface crack-testing equipment with fluorescent penetrant dye				



C 011.05 Crankcase

C 011.05.01 General View

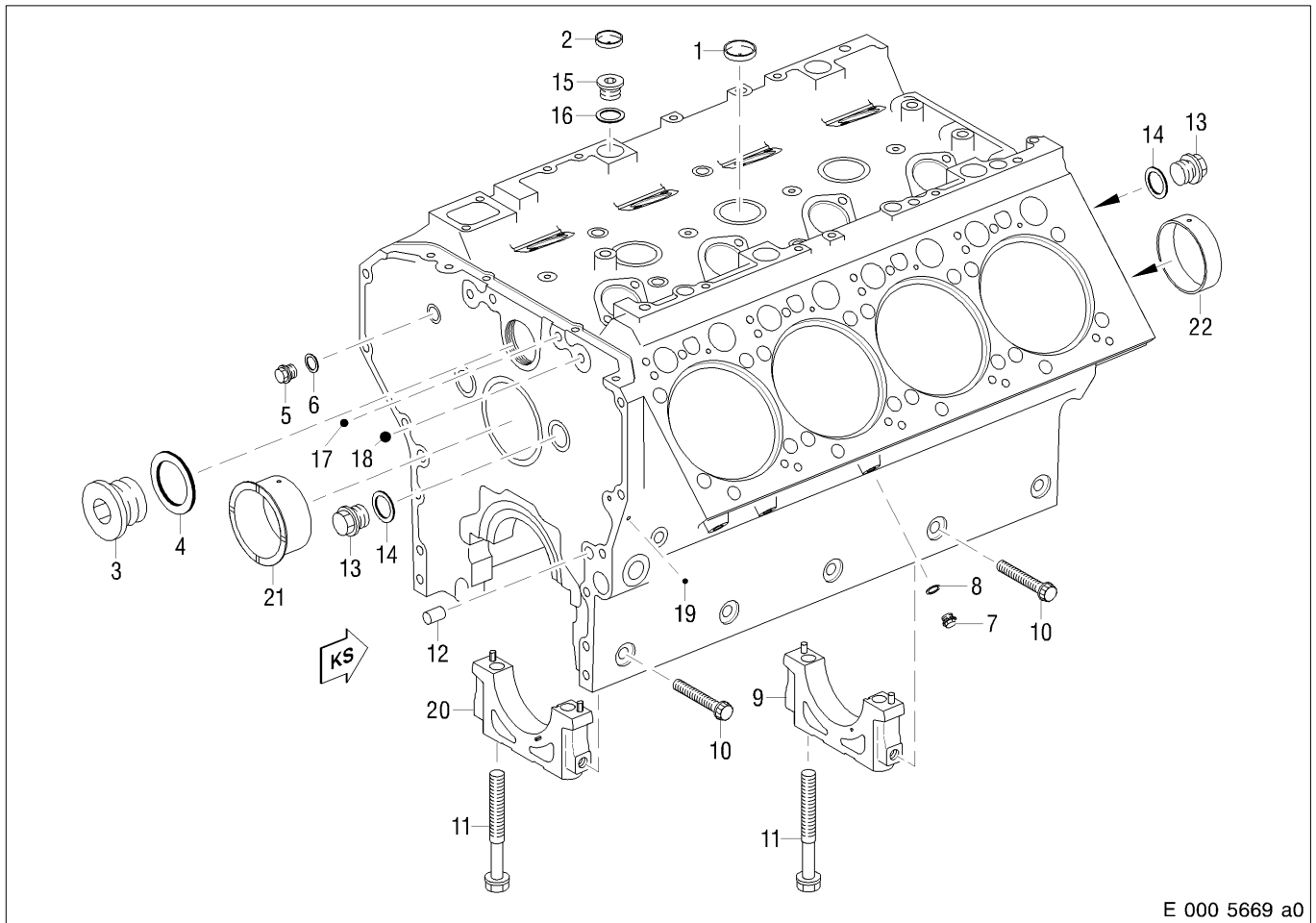

E 000 5669 a0

- | | |
|--|---|
| 1 End cover
Lubricant: Thread-locking liquid | 11 Hex screw*
Max. shaft length: 176 mm
Pretightening torque: 300 Nm + 30 Nm
Angle of further rotation: 90° + 10°
Lubricant: Engine oil |
| 2 End cover
Lubricant: Thread-locking liquid | 12 Dowel pin |
| 3 Plug
Tightening torque: 350 Nm + 20 Nm
Lubricant: Engine oil | 13 Plug
Tightening torque: 180 Nm
Lubricant: Engine oil |
| 4 Sealing ring | 14 Sealing ring |
| 5 Plug
Tightening torque: 80 Nm
Lubricant: Engine oil | 15 Plug
Tightening torque: 150 Nm
Lubricant: Engine oil |
| 6 Sealing ring | 16 Sealing ring |
| 7 Plug | 17 Ball |
| 8 Sealing ring | 18 Ball |
| 9 Crankshaft bearing cap | 19 Ball |
| 10 Double-hex screw*
Tightening torque: 120 Nm + 10 Nm
Lubricant: Engine oil | 20 Crankshaft alignment bearing cover |
| | 21 Camshaft bearing |
| | 22 Camshaft bearing |

* Tightening sequence: Hex bolts before double-hex screws

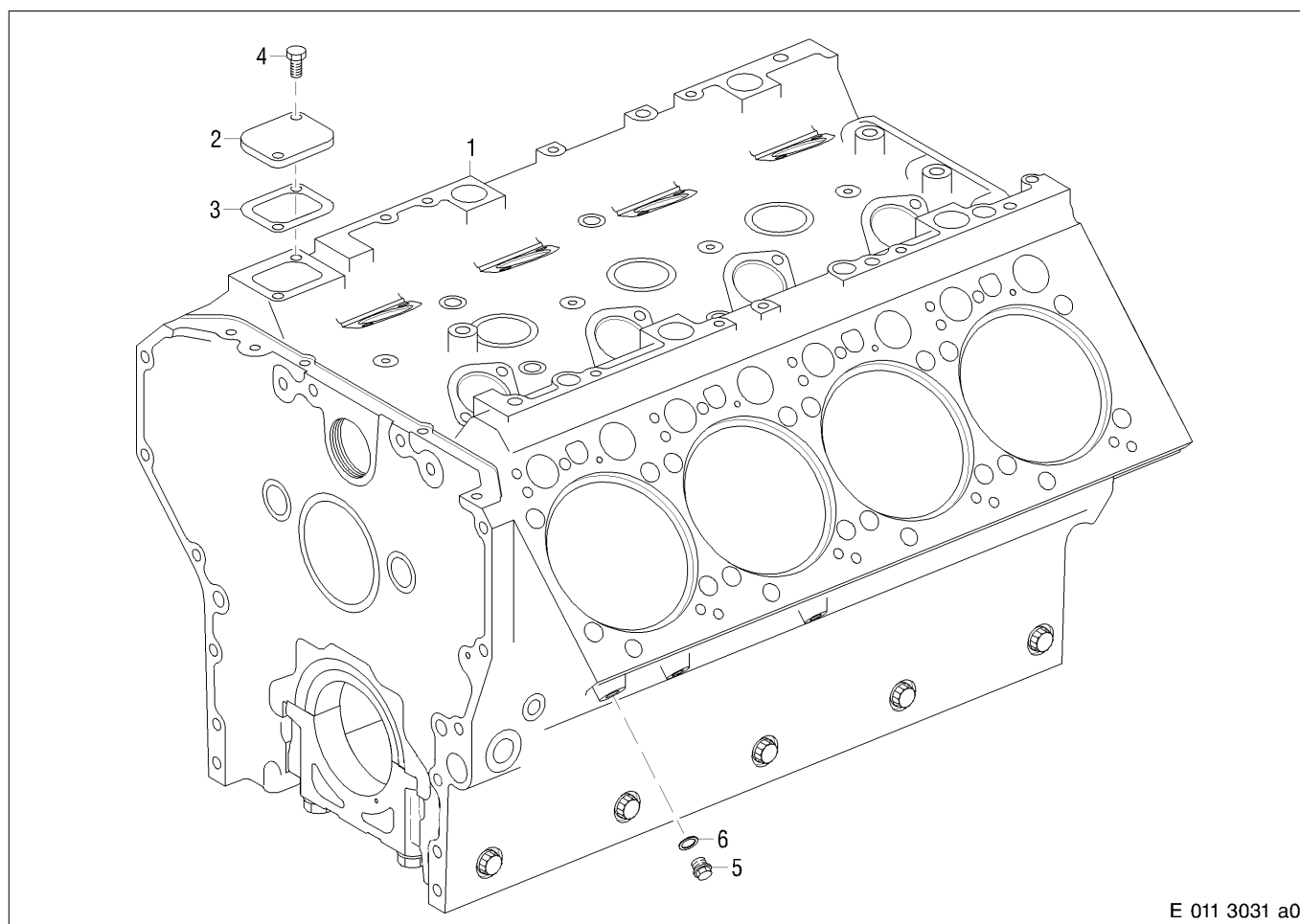

- 1 Crankcase
- 2 Cover
- 3 Gasket

- 4 Hex screw
- 5 Plug
- 6 Sealing ring

C 011.05.02 Special tool

Designation – Application	Number
Guide tube for camshaft bearing	1
Stop pin for guide tube	1
Removal tool for camshaft bearing	1
Shrinking tool for camshaft bearing	1
Mandrel for end cover	1

C 011.05.04 Before-Removal Operations

A distinction must be made as to whether:

- 1 ————— The engine is to be completely disassembled
- 2 ————— The engine is to be removed but not disassembled
- 3 ————— The engine is to remain installed

1	2	3	Operations	See
x	-	-	Remove engine	B 003
x	-	-	Perform operations as per Disassembly Plan	B 004
-	x	x	Removal not scheduled	-

C 011.05.08 Inspection and Repair

Clean all components.

Using the surface crack-testing method with red penetrant dye, check crankcase for cracks.

Check mating faces and upper and lower fits for cylinder liners in crankcase for wear, damage and cavitation.

In event of wear and damage to balcony seat and/or cylinder liner fittings, recondition all balcony seats and cylinder liner bores to next repair stage. It is imperative to contact MTU and/or DDC .

For limit values, see Tolerances and Wear Limits List.

Check camshaft bearing bushes for wear and damage; replace if necessary.

Check all mating faces, sealing faces and fits; rub down with an oilstone or emery cloth as necessary.

Check bores for dowel pins in crankcase for damage; recondition if necessary.

Check condition of all threads; re chase threads if necessary.

Replace sealing rings.



CAUTION

Compressed air is air which has been compressed under pressure. If compressed air is used for blowing out or blow-drying components, always wear protective goggles or safety mask. Compressed air must not be directed at the body. The pressure must not exceed 3.0 bar (40 lb/in²).

Flush oilways in crankcase with "cleaner", using as high a pressure as possible and blow clear with compressed air.

Note: If the crankcase and/or engine is not put into operation immediately, dry oil bores, preserve and seal air-tight with suitable end covers.

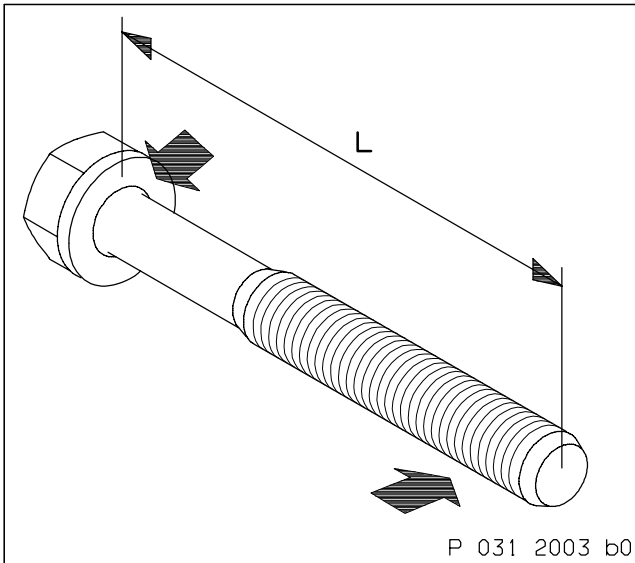

Checking hex screws for crankshaft bearing cap

Measure shaft length (L) of central hex screws for crankshaft bearing cap. For max. shaft length, see C 011.05.01.

Check that thread and screw head mating face (arrows) are in perfect condition; replace screw if necessary.

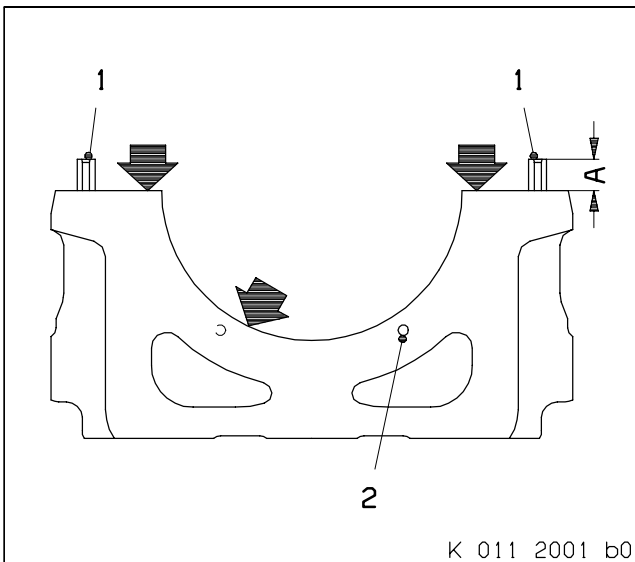

Checking crankshaft bearing cap and crankshaft alignment bearing cover

Using the magnetic crack-testing method and fluorescent magnetic powder, check crankshaft bearing caps for cracks, and replace as necessary.

Check partition and bearing shell support surfaces (arrows), both grooved pins (2), cylinder and dowel pins (1) for damage; replace if necessary.

Measure projection of cylinder pins, dowel pins and grooved pins.

Projection (A) of cylinder pins and dowel pins = from 12 mm to 13.5 mm

Projection of grooved pins = from 4.5 mm to 4.7 mm

Check position of dowel pins.

Wide end of the dowel pins must face parallel to longitudinal axis of crankshaft main bearing bore.

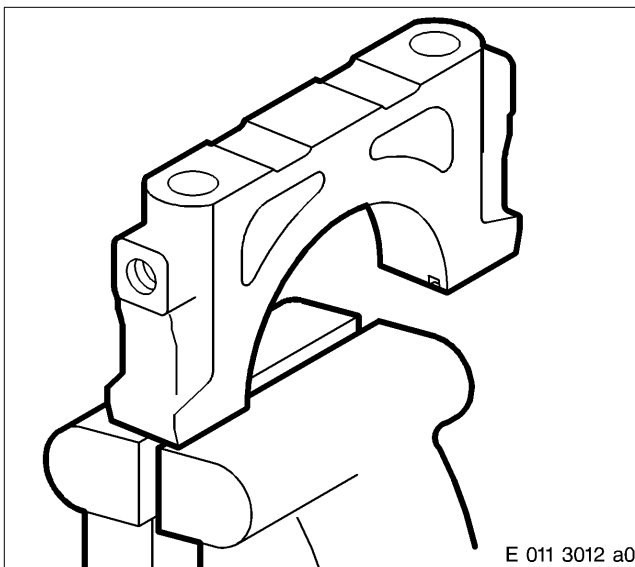

Replacing dowel pins for crankshaft bearing cap

Clamp crankshaft bearing cap on dowel pin in vice and carefully remove dowel pin.

Clean crankshaft bearing cap.

Use a copper hammer to drive in new dowel pin.

Measure projection (A) of dowel pins, see previous illustration.

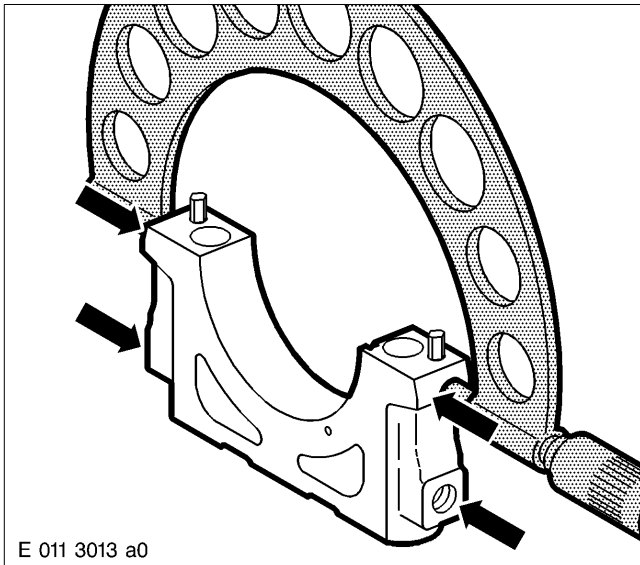

Measuring bearing cap width

Using micrometer, measure width of main bearing cap at upper and lower fits (arrows).

For limit values – see Tolerances and Wear Limits List.

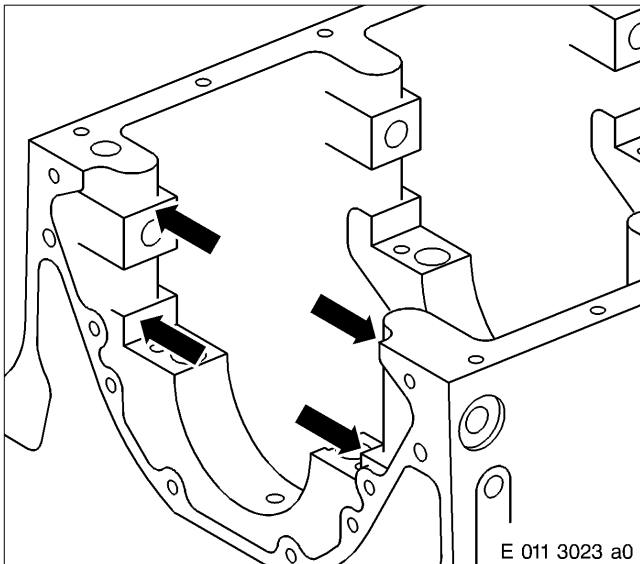

Measuring bearing cap guides

Using internal micrometer (1), measure bearing cap guides at upper and lower fits.

For limit values, see Tolerances and Wear Limits List.

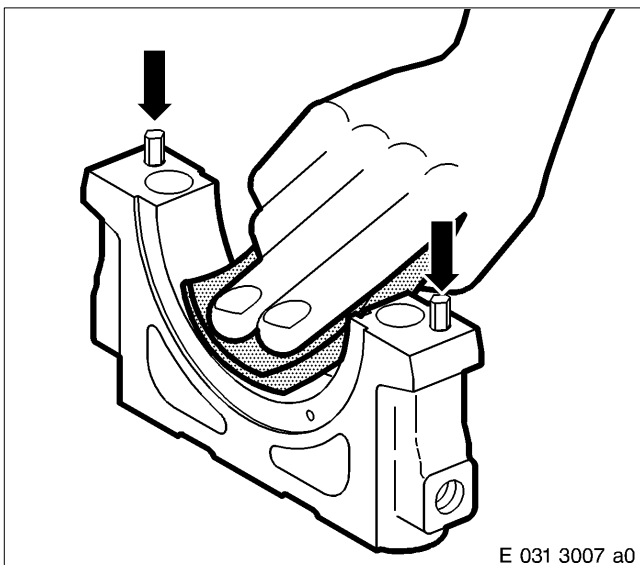

Installing main bearing caps

Crankcase is upside down, with oil pan mating face horizontal.

Wipe bearing shell mating faces on crankshaft bearing cap.

CAUTION

Compressed air is air which has been compressed under pressure. Risk of injury. If compressed air is used for blowing out or blow-drying components, always wear protective goggles or safety mask. Compressed air must not be directed at the body. The pressure must not exceed 3.0 bar (40 lb/in²).

Blow out partitions on crankshaft bearing cap and crankcase, cylinder and dowel pins (arrows) and related bores in crankcase with compressed air and check that they are perfectly clean.

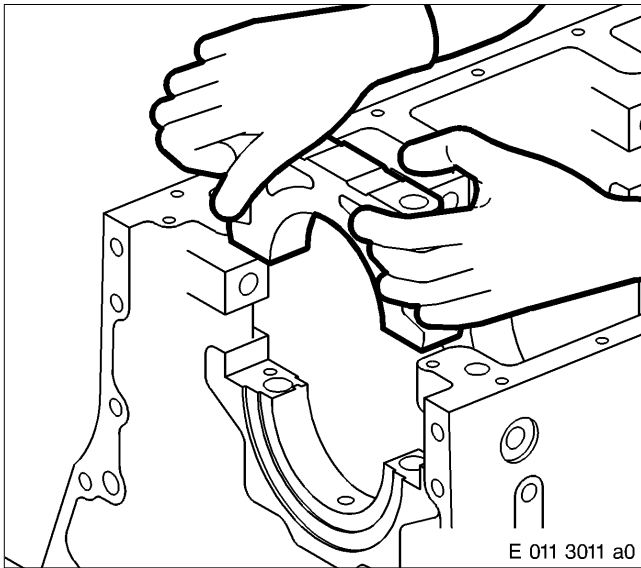

⚠ CAUTION
Components have sharp edges.
Risk of injury.
Touch components only when wearing protective gloves.

Fit bearing caps according to marking, (see next illustration), on appropriate crankcase bearing and secure by hitting with a copper hammer.

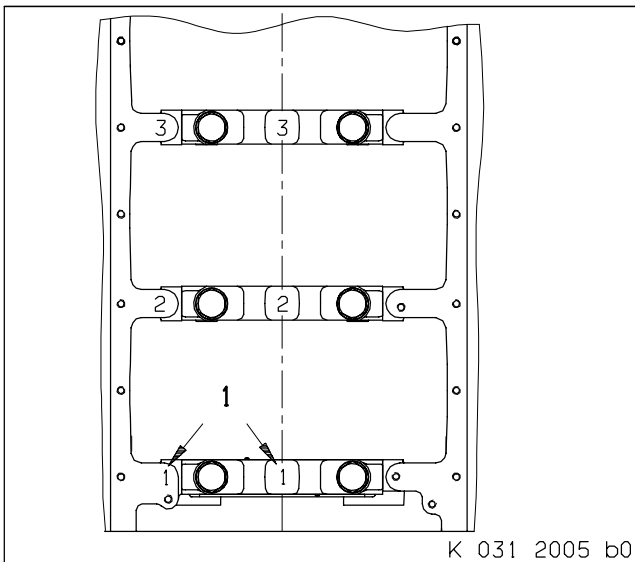

1 – Consecutive numbering of the main bearing starting from the driving end.

Note: Crankshaft bearing caps must not be interchanged!

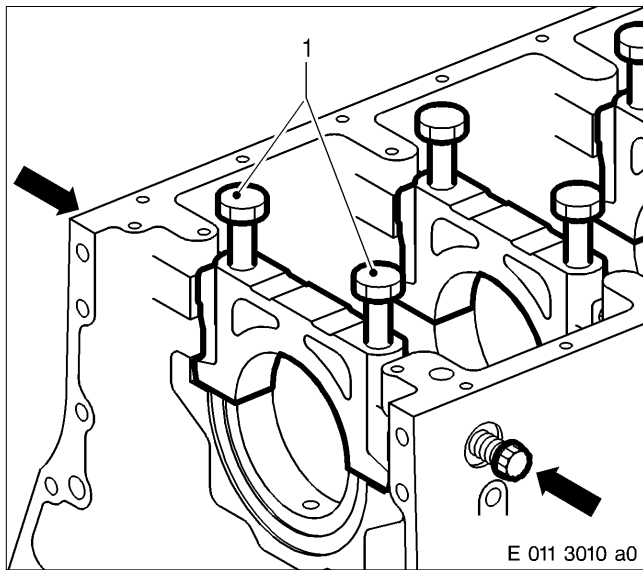

Coat thread and underside of screw of centre hex screws (1) with engine oil.

Fit hex screws.

Coat thread and mating face of side double-hex screws (arrows) with engine oil and insert double-hex screws but do not tighten.

Note: Always tighten screws on one bearing at same time.
Always start tightening sequence from alignment bearings.

Pretighten central screws to specified pretightening torque, see C 011.05.01.

Mark screw heads.

Tighten screws through specified angle of further rotation.

Simultaneously tighten side double-hex screws to specified torque in same sequence as for central screws – see C 011.05.01.

Note: Tighten screws on one bearing at same time.

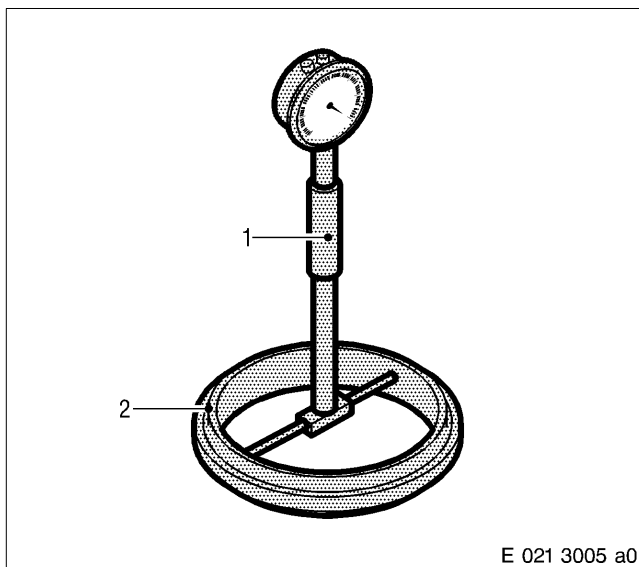

Setting bore gauge

Adjust bore gauge (1) and dial gauge with adjusting ring or micrometer to basic size of respective bore to be measured.

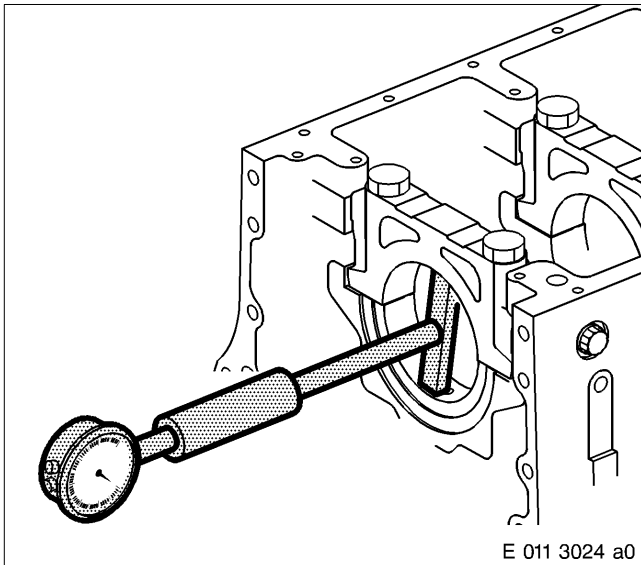

Measuring crankshaft main bearing bore

Using bore gauge, measure crankshaft main bearing bore.

Enter measurement values in data sheet.

For measurement planes and limit values, see Tolerances and Wear Limits List.

If limit values are exceeded, machine locating bore in question to repair size.

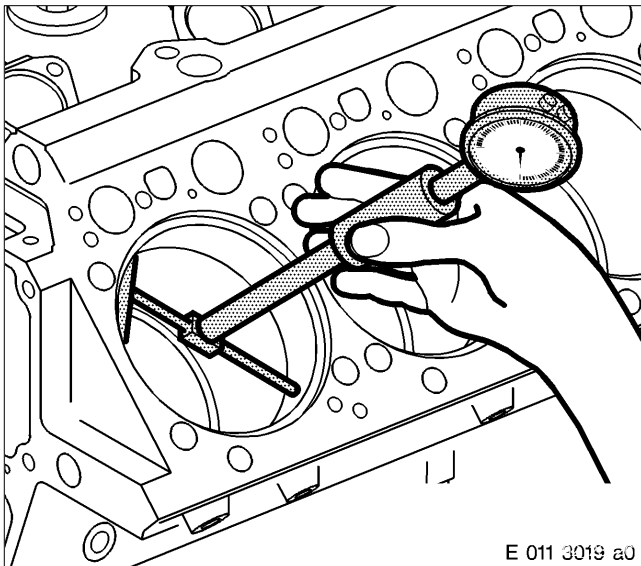

Measuring crankcase bores for cylinder liners

Using bore gauge, measure upper and lower fits of cylinder liner locating bores.

Enter measurement values in data sheet.

For limit values, see Tolerances and Wear Limits List.

If limit values are exceeded, machine all collared bush recesses and cylinder liner bore in question to next repair size.

It is imperative to contact MTU and/or DDC.

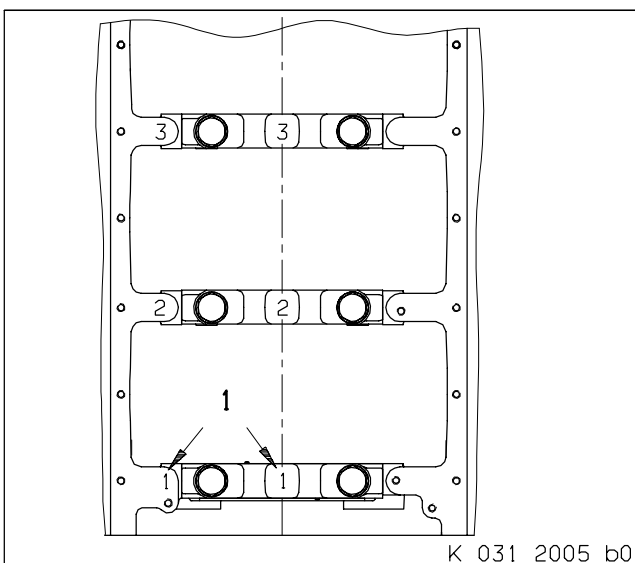

Removing main bearing caps

Crankcase is upside down, with oil pan mating face horizontal.

Check marking on crankshaft bearing cap to crankshaft, and if necessary mark according to sequence.

1 – Starting at driving end, stamp on consecutive numbers with 6 mm digits so that they can be read from same direction.

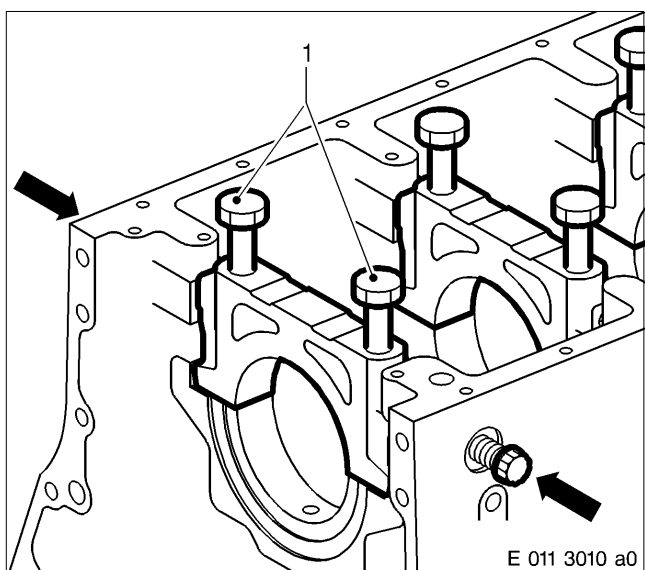

Remove all double-hex screws (arrows) and then all central hex screws (1) for crankshaft bearing cap.

Note: Release screws on one bearing at same time.

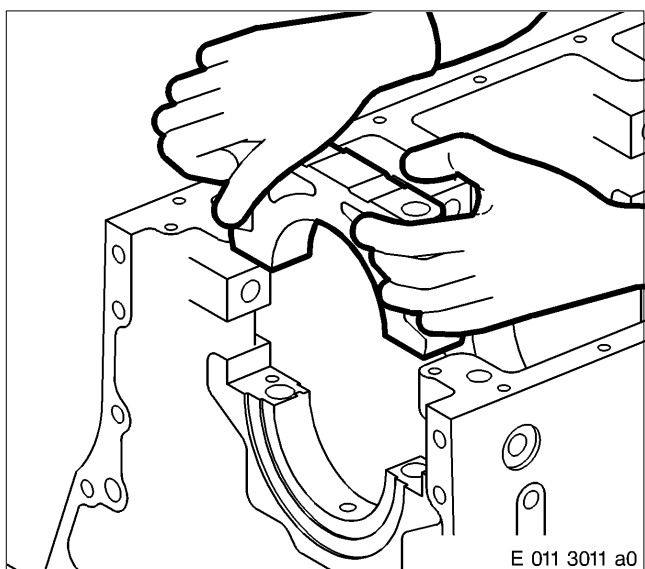

CAUTION

**Components have sharp edges.
Risk of injury.
Touch components only when wearing protective gloves.**

Carefully raise all bearing caps vertically until clear of crankcase.

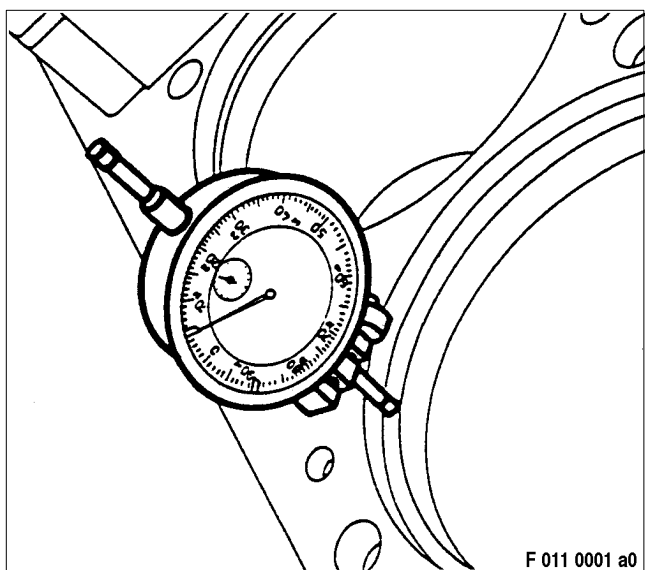

Measuring balcony depth

Secure dial gauge to dial gauge holder.

Fit dial gauge stylus on collared bush recess on crankcase

Check preload (approx. 3 – 4 mm) of dial gauge.

Set dial gauge scale to zero.

Fit dial gauge stylus on end face of crankcase and read off balcony depth.

Enter measurement values in data sheet.

For limit values, see Tolerances and Wear Limits List.

If limit values are exceeded, machine all collared bush recesses and cylinder liner bore in question to next repair size.

It is imperative to contact MTU and/or DDC.

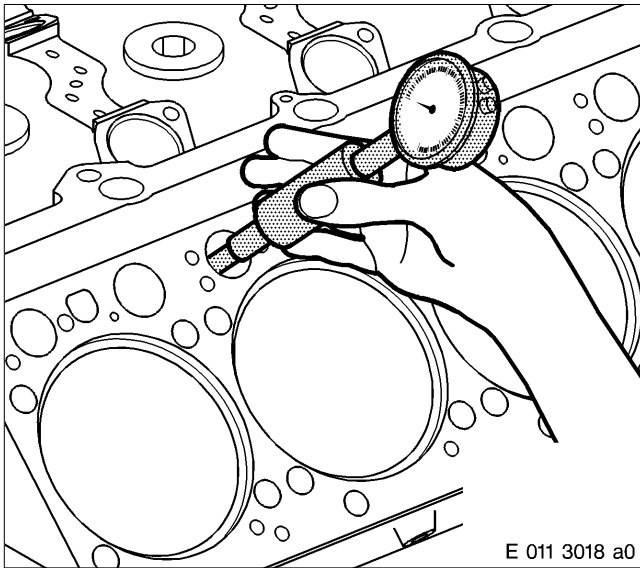

Measuring bore for valve tappet

Measure bore with bore gauge.

For limit values, see Tolerances and Wear Limits List.

If limit values are exceeded, machine bore in question to repair size.

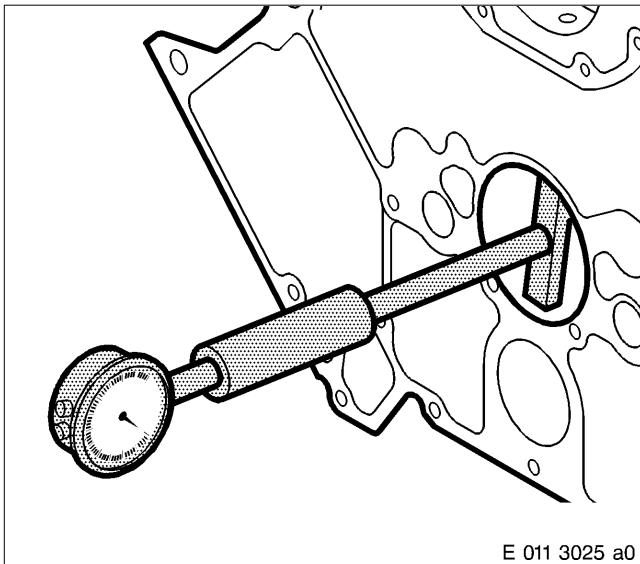

Measuring camshaft bearing bush bore

Using bore gauge, measure camshaft bearing bush bore.

For limit values, see Tolerances and Wear Limits List.

Replace all camshaft bearing bushes if limit values are exceeded.

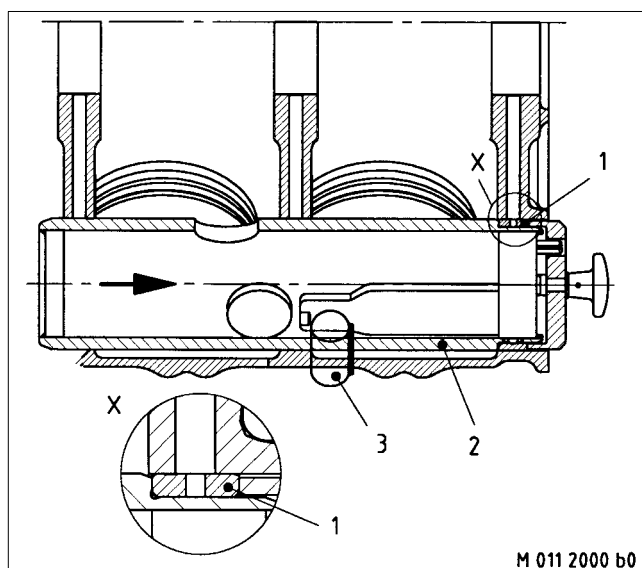

Replacing camshaft bearing shell

Using suitable mandrel, carefully drive camshaft bearing bushings out of crankcase.

Using bore gauge, measure main bore for camshaft bearing bush in crankcase.

For limit values, see Tolerances and Wear Limits List.

Enter measurement values in data sheet.

If limit values are exceeded, machine locating bore in question to repair size.

Note: Make sure parts are perfectly clean. Installation sequence of camshaft bearing, starting from free end, continuing in direction of free end.

Crankcase is upside down, with oil pan mating face horizontal.

Insert stop pin (3) into first exhaust tappet bore of B side.

Observe fit of stop pin dowel pin in guide slot of roller tappet bore.

Insert guide tube (2) for camshaft bearing into crankcase before first bearing point on free end.

CAUTION

Nitrogen is liquid at, -200 °C (-328 F). Danger of freezing and suffocation!

Do not allow liquid nitrogen to come into contact with parts of body (eyes, hands).

Wear protective clothing (including gloves and closed shoes) and goggles.

Ventilate working area well.

Chill camshaft bearing bush (1) in liquid nitrogen and mount on guide tube so that oil bore faces upwards.

Note: After installation, ensure that lube oil bores of bearing bush and crankcase are aligned!

Insert guide tube in direction of free end (arrow) until it contacts stop on stop pin and insert cam shaft bearing bush in camshaft basic bore.

Once bearing bush has reached room temperature, remove guide tube and stop pin and install next camshaft bearing bush in method described.

Check alignment of lube oil bores; if bores are not aligned, replace bearing bush.

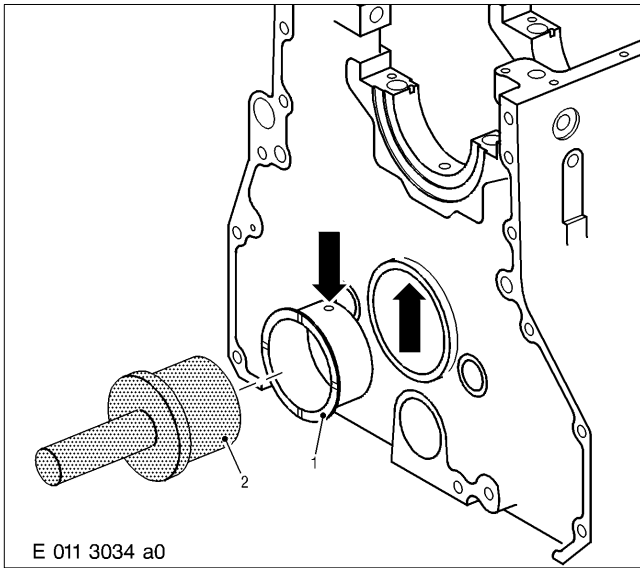

Chill last camshaft bearing bush (1) and, using shrink-on tool, insert flush into camshaft base bore from driving end and check alignment of lube oil bores (arrows).

After installation, machine camshaft bearing bush bores to finished dimension.

It is imperative to contact MTU and/or DDC.

After machining, measure diameter of camshaft bearing bush bores.

For limit values, see Tolerances and Wear Limits List.

Clean lube oil bores and ensure they are perfectly clean and unobstructed.

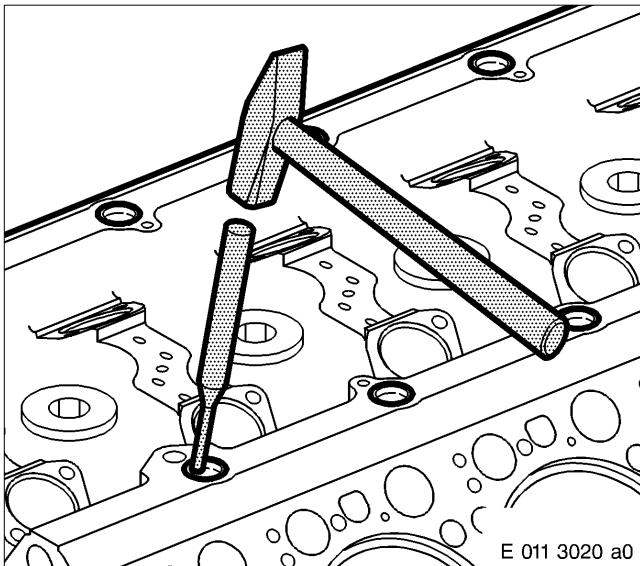

Replacing end covers

Note: Replace end cover only if necessary (e.g. in event of leakages).

Using a mandrel (1) and hammer, carefully tap cover into bore at one side until it tilts. Use pliers to remove cover from bore.

When removing, take great care that cover does not fall into bore and that sealing face of bore is not damaged.

Never attempt to drill a hole in cover, as chips of metal in engine cooling jacket can cause localized overheating.

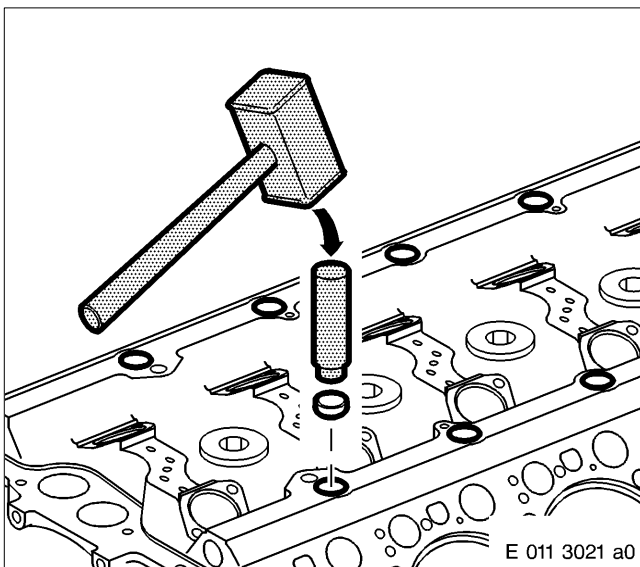

Clean and degrease seating faces of cover and bore in crankcase.

Coat seating face of cover with thread locking compound.

Using mandrel and hammer, drive cover into bore.

Note: Ensure correct final strength of thread-locking agent, see C 010!

Checking oil bores

Note: All oilways must be thoroughly cleaned as part of every major overhaul or if metal chips penetrate engine oil system. Always make sure oilways are perfectly clean.

Remove plugs for main oil channels as shown in General View – see C 011.05.01.

Use an endoscope and cold-light source to examine oilways and fuel bores shown in following illustrations, making sure they are perfectly clean.

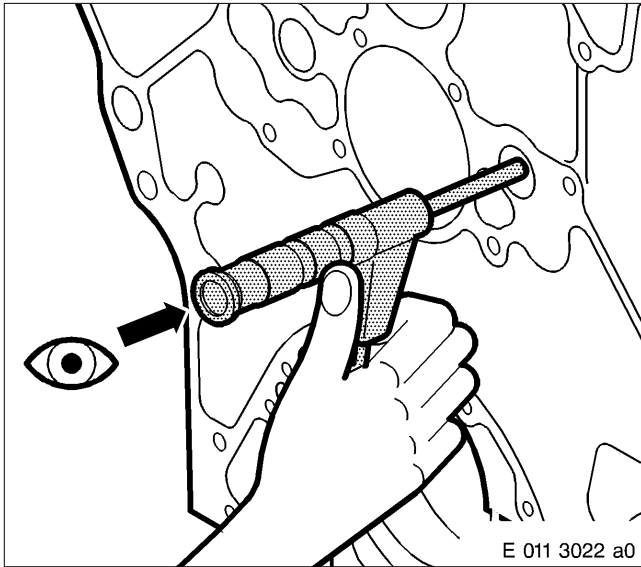

Both main oil galleries

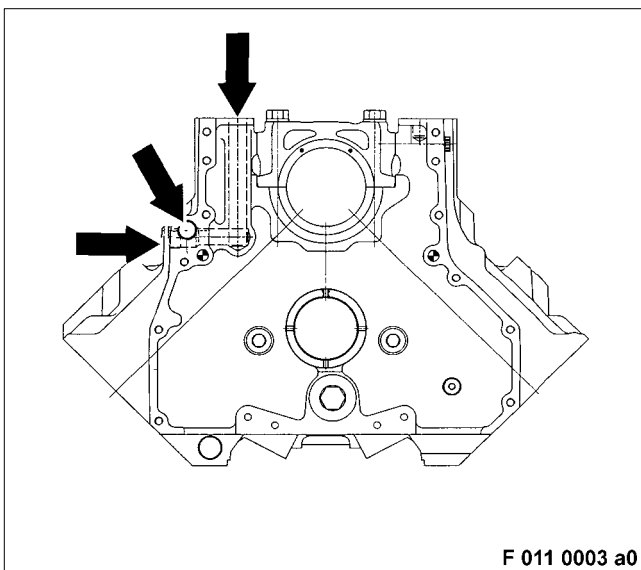

Oil ducts (arrows) from oil pump to main oil gallery

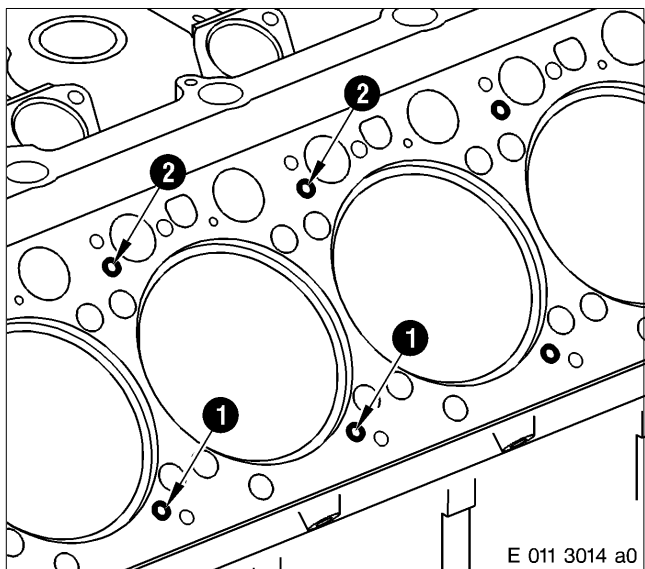

Oil bores (2) for camshaft bearing and valve gear, oil return bores (1)

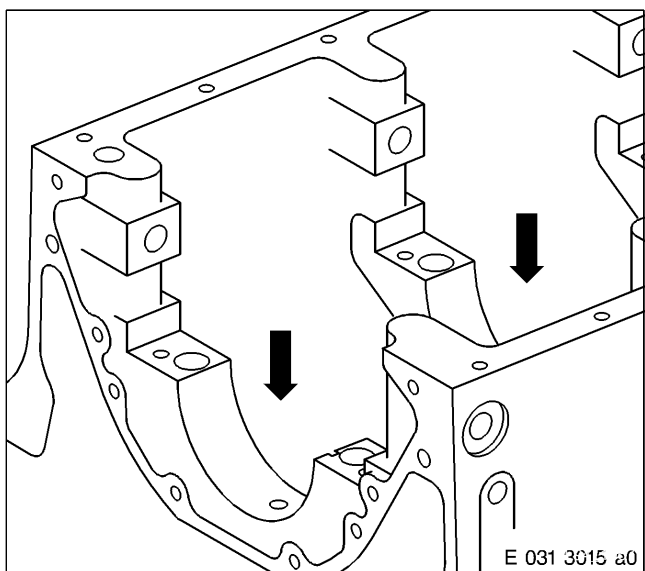

Oil bores (arrows) to main bearings

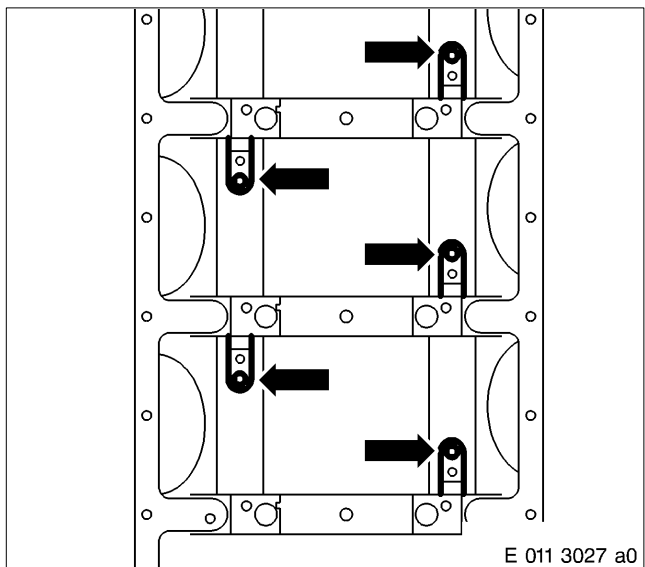

Oil bores (arrows) for oil spray nozzles

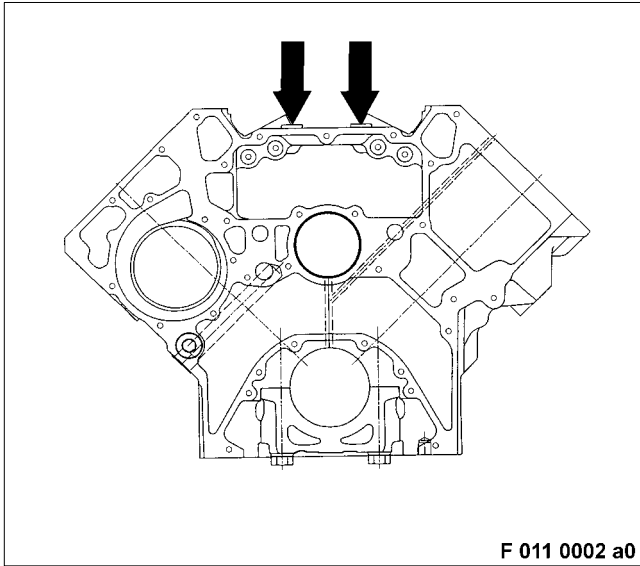

Fuel supply bores and fuel return bores (arrows) in Vee chamber

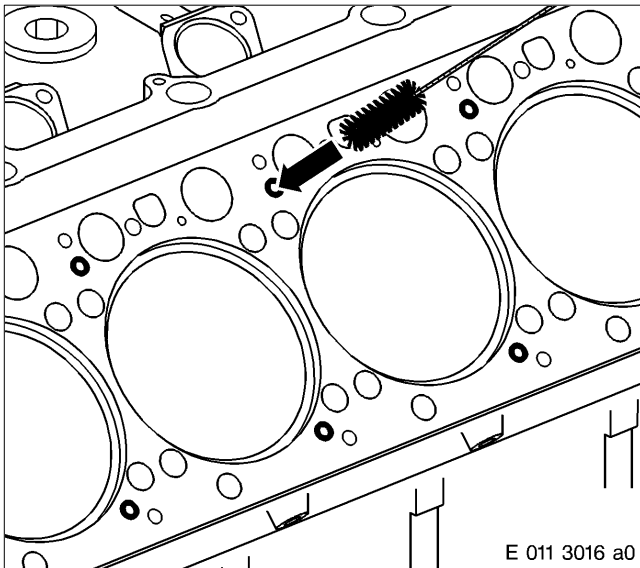

If necessary, clean oil bores (arrow) and/or fuel bores with bristle brush.

Note: Never use a wire brush!

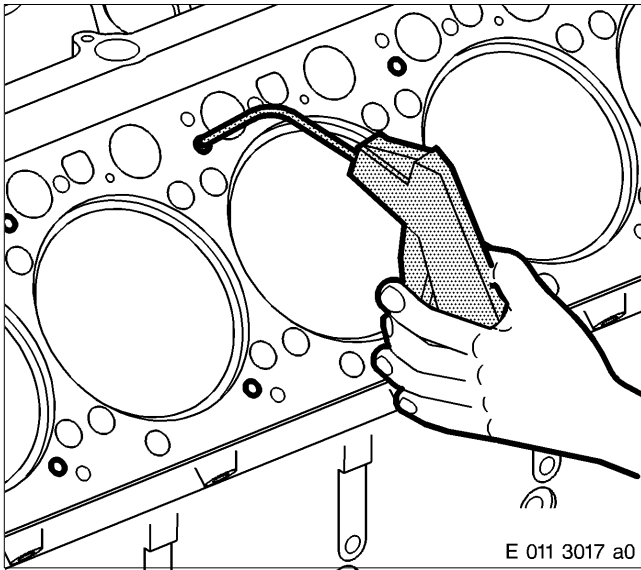

⚠ CAUTION

Compressed air is air which has been compressed under pressure. Risk of injury. If compressed air is used for blowing out or blow-drying components, always wear protective goggles or safety mask. Compressed air must not be directed at the body. The pressure must not exceed 3.0 bar (40 lb/in²).

After cleaning, flush bores with "cleaner" (under high pressure if possible) and blow clear with compressed air.

Note: If the crankcase and/or engine is not put into operation immediately, dry oil bores, preserve and seal air-tight with suitable end covers.

Insert plugs and sealing rings in accordance with General View – see C 011.05.01, and tighten to specified tightening torque.

C 011.05.12 After-Installation Operations

A distinction must be made as to whether:

- 1 ————— The engine is to be completely disassembled
- 2 ————— The engine is to be removed but not disassembled
- 3 ————— The engine is to remain installed

1	2	3	Operations	See
x	-	-	Perform operations as per Assembly Plan	B 005
x	-	-	Install engine	B 007

C 013.05 Cylinder Liner

C 013.05.01 General View

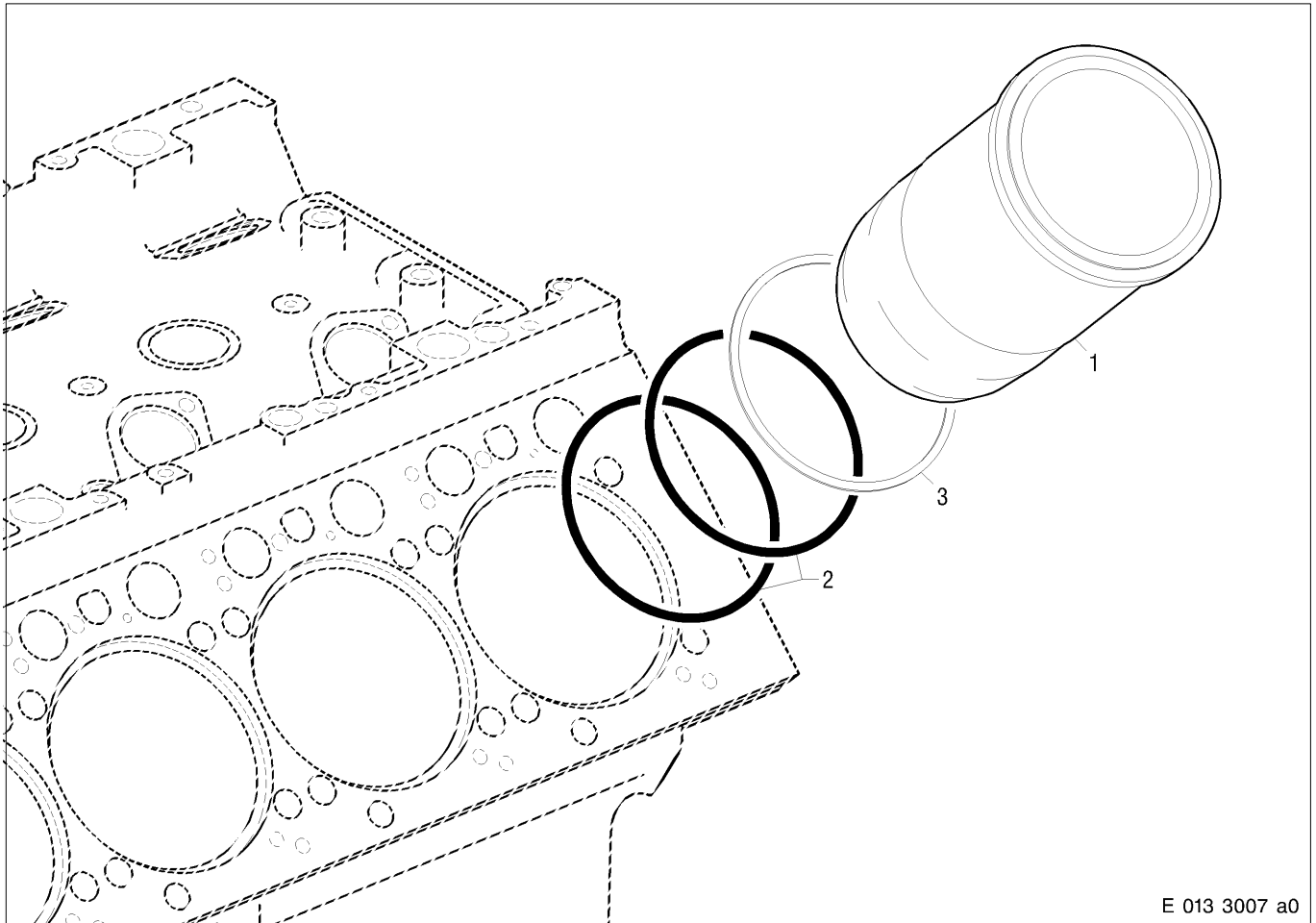

E 013 3007 a0

- 1 Cylinder liner
- 2 Sealing ring, bottom
- 3 Sealing ring (Tombak)

Cylinder liner in crankcase

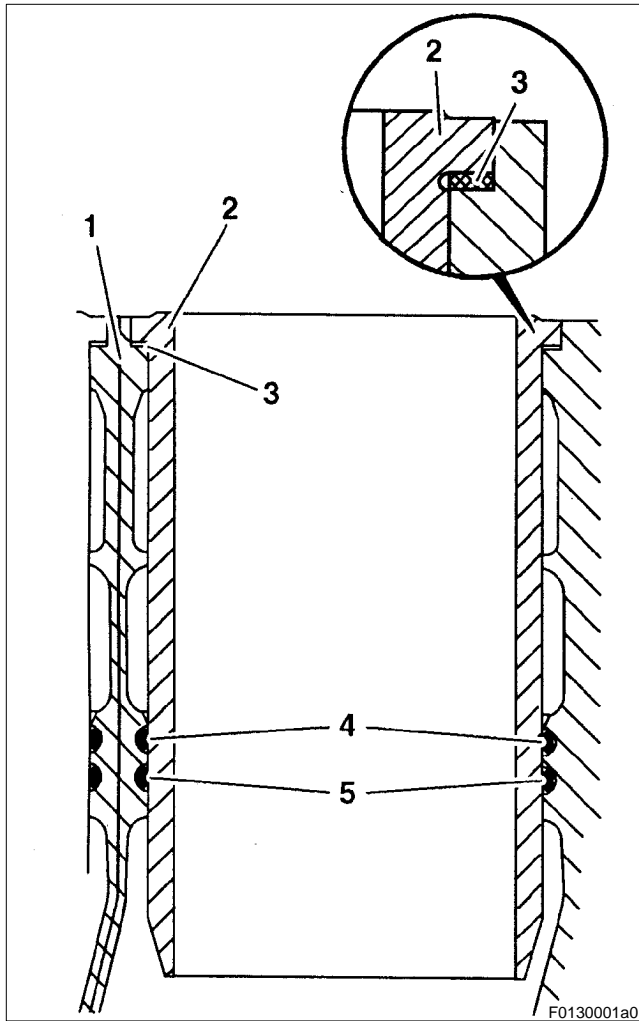

- 1 Crankcase
- 2 Cylinder liner
- 3 Sealing ring (Tombak)
- 4 Sealing ring, bottom
- 5 Sealing ring, bottom

C 013.05.02 Special Tool

Designation – Application	Number
Removal tool for cylinder liner	1
Installation tool for cylinder liner	1
Measuring plate for cylinder liner projection	1
Spacer tubes for cylinder liner projection	4

C 013.05.04 Before-Removal Operations

A distinction must be made as to whether:

- 1 ————— The engine is to be completely disassembled
- 2 ————— The engine is to be removed but not disassembled
- 3 ————— The engine is to remain installed

1	2	3	Operations	See
x	-	-	Remove engine	B 003
x	-	-	Perform operations as per Disassembly Plan	B 004
-	-	x	Disable engine start	Operating Instructions
-	-	x	Drain engine coolant	Operating Instructions
-	-	x	Drain or draw off engine oil	Operating Instructions
-	x	x	Remove air pipework before exhaust turbocharger (if necessary)	-
-	x	x	Remove crankcase ventilation (if necessary)	C 018.10
-	x	x	Disconnect or remove electrical cable (if necessary)	-
-	x	x	Release or remove charge air manifold	C 124.05
-	x	x	Remove exhaust turbocharger	C 101.01
-	x	x	Removing exhaust manifold	C 142.05
-	x	x	Cylinder head cover removal	C 055.10
-	x	x	Remove H.P. fuel line	C 073.05
-	x	x	Disconnect leak-off fuel lines	C 086.05
-	x	x	Removing rocker arm assembly	C 055.05
-	x	x	Removing pushrods	C 054.05
-	x	x	Remove cylinder head	C 041.05
-	x	x	Removing oil pan	C 014.05
-	x	x	Remove piston and conrod	C 037.05

C 013.05.05 Removal

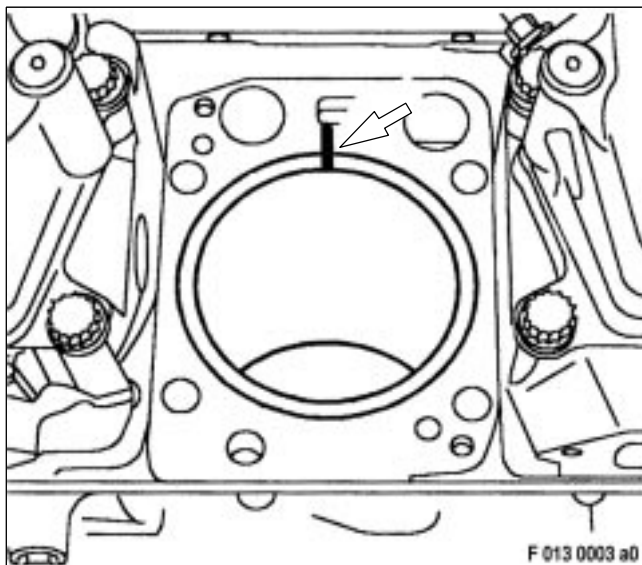

Removing cylinder liner

Mark installation position of cylinder liner in crankcase (arrow).

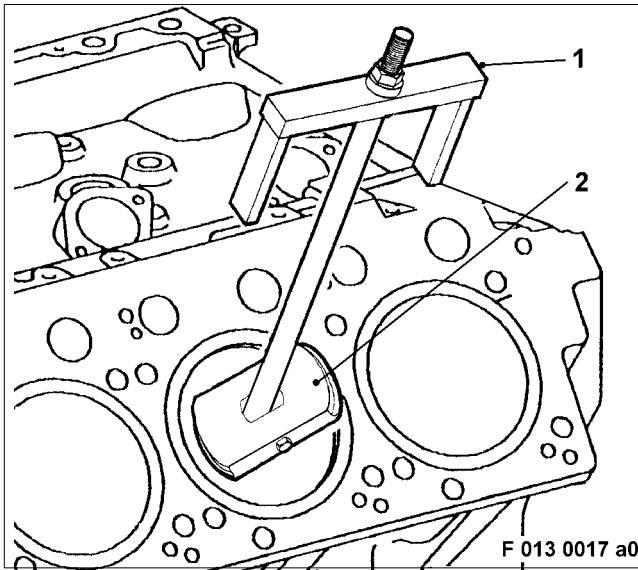

Insert removal plate (2) of removal tool (1) into cylinder liner and fit on bottom collar of cylinder liner. Make sure that removal plate is correctly seated. Turn nut of removal tool in clockwise direction and remove cylinder liner until cylinder liner is released from the crankcase bore. Remove removal tool. Remove cylinder liner from crankcase. Remove Tombak ring and sealing rings from crankcase.

C 013.05.08 Inspection and Repair

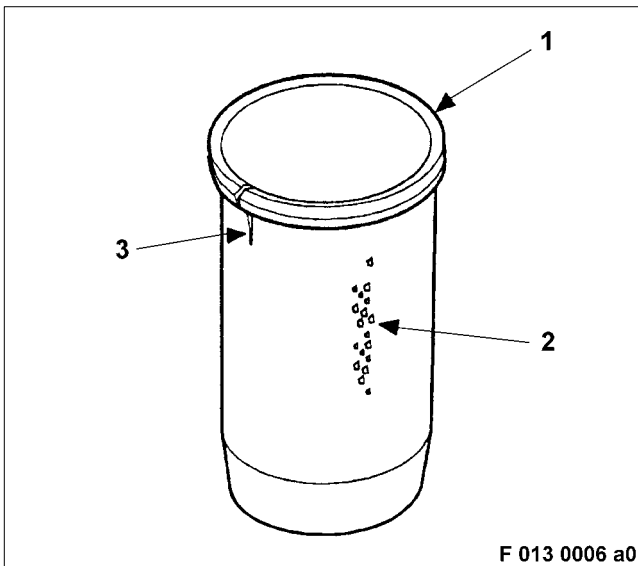

Checking cylinder liner for cracks and cavitation

Clean cylinder liner and, using magnetic crack-testing method and fluorescent magnetic powder, check for cracks (3).

If cracks are found, replace cylinder liner.

Check outer wall for cavitation (2) and pitting; replace cylinder liner as necessary.

If minor cavitation and pitting are found, insert cylinder liner displaced by 90°.

If cylinder liner has to be turned for re-installation, re-hone liner bore.

Check sealing and mating faces on liner collar (1) for wear and damage; replace cylinder liner if necessary.

Replace sealing rings and Tombak ring.

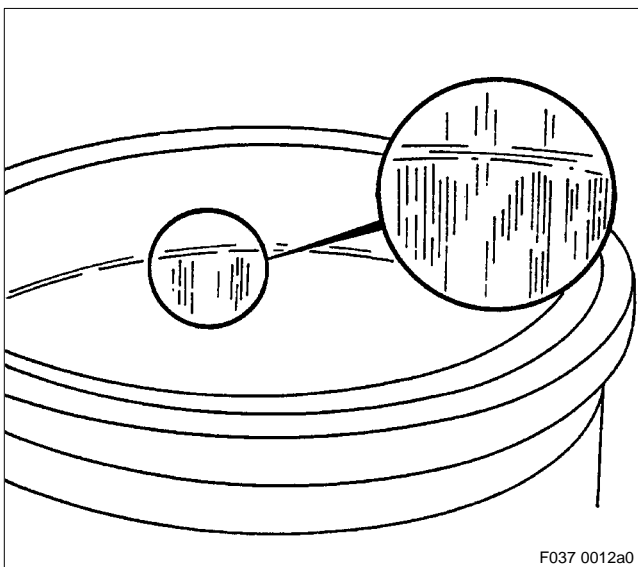

Checking wear pattern of cylinder liners

Check wear face for flats, scores, cracks and pitting; rehone or replace cylinder liner as necessary.

Note: If cylinder liner is rehoned, install new piston rings. Similarly, rehone liner if new piston rings are installed.

No burn marks must be evident on running surface.

Check reversing point of initial piston ring for wear; replace cylinder liner if necessary.

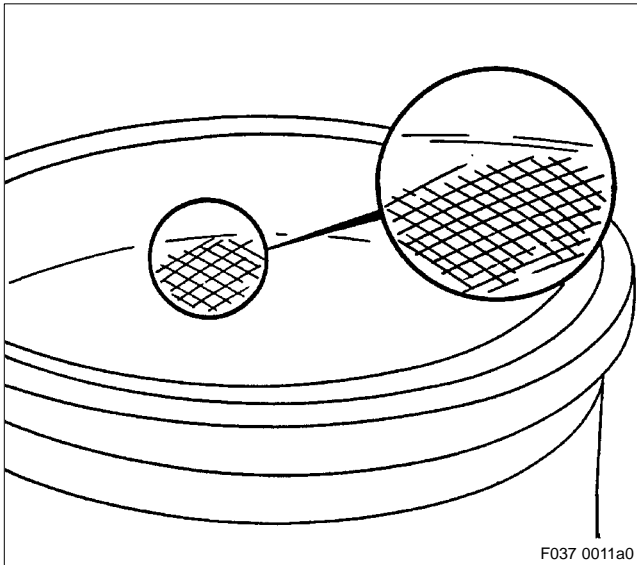

When reusing cylinder liners which have not been re-honed, the honing must be more or less clearly recognisable over entire running surface. Isolated minor grooves are insignificant. There must be no signs of wear at reversing point of initial piston ring.

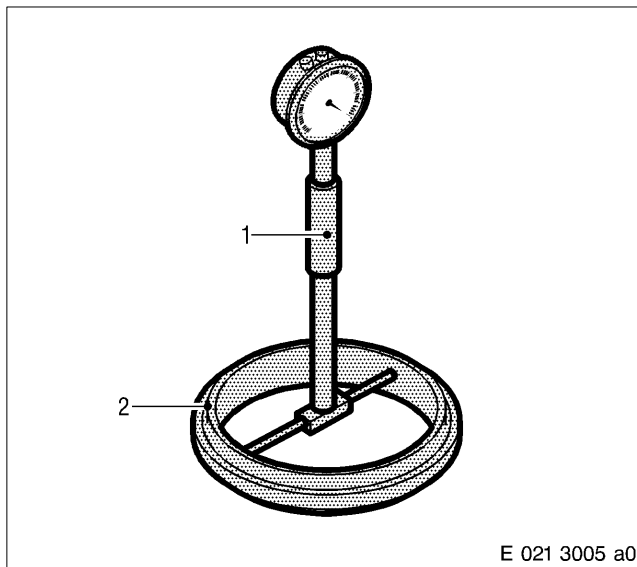

Measure cylinder liner I.D.

Adjust bore gauge (1) and dial gauge with micrometer or gauge ring (2) to basic size for cylinder liner as per Tolerances and Wear Limits List.

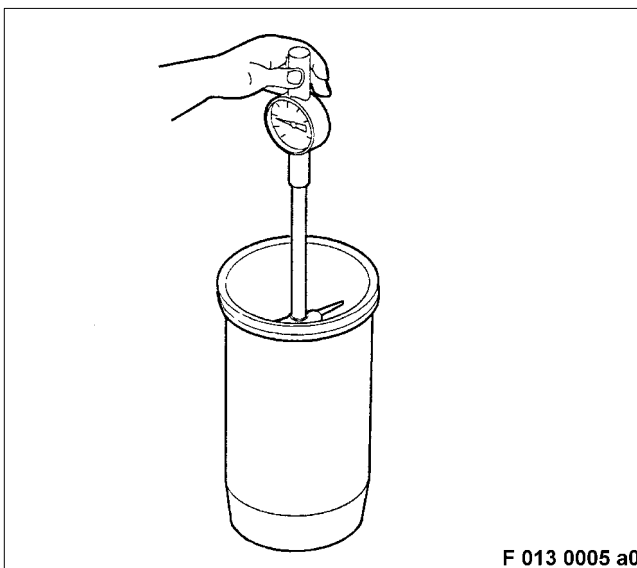

Measure cylinder liner I.D. with bore gauge. For measuring points and limit values, see Tolerances and Wear Limits List. Replace cylinder liner if measured values are exceeded.

C 013.05.11 Installation

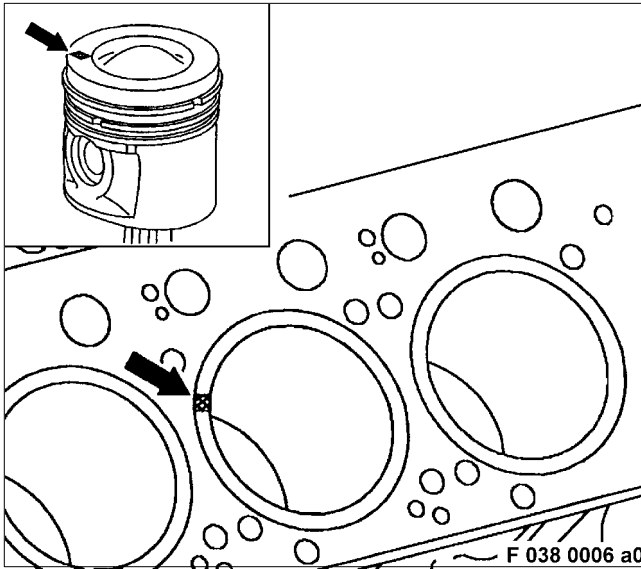

Installing cylinder liner

Note: If new cylinder liners are installed, assign each cylinder liner to the respective piston in accordance with the tolerance group designation.

The tolerance group designation (arrows) is stamped on the piston crown and edge of liner.

Designation

Piston ⇒ Cylinder liner

BA ⇒ A or B

BC ⇒ B or C

Check cylinder liner repair stage as per Tolerances and Wear Limits List and assign according to crankcase data sheet.

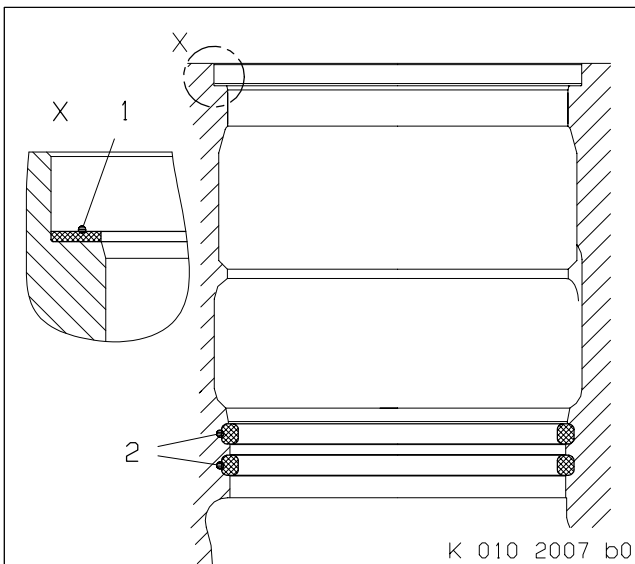

Coat new sealing rings (2) with petroleum jelly and insert into grooves in crankcase.

Fit new Tombak ring (1) on cylinder liner collar seat in crankcase.

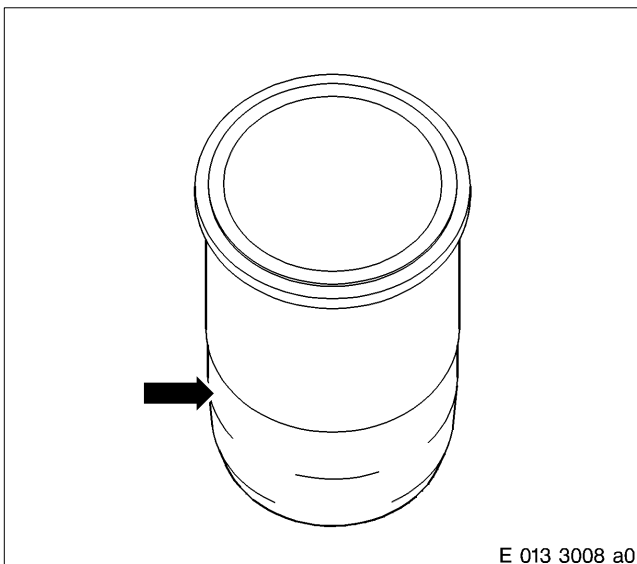

Wipe cylinder liner at lower fit (arrow) and at chamfer inclination; then lightly coat with petroleum jelly.

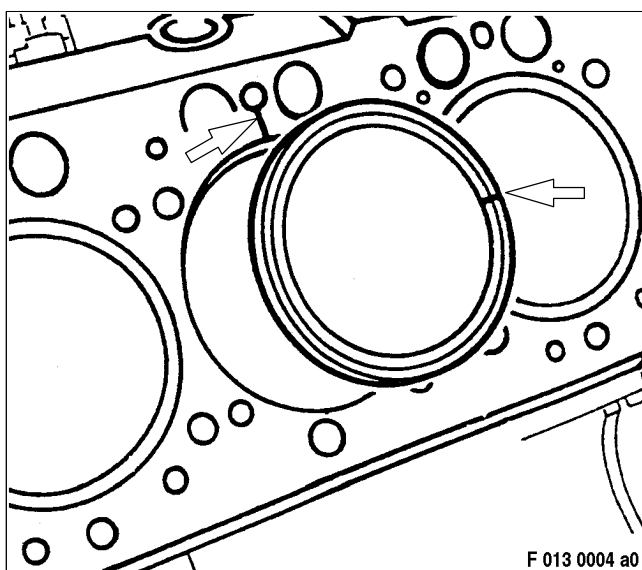

According to markings, insert cylinder liner in same installation position in crankcase.

Note: In event of slight cavitation on the outer wall of cylinder liner, install liner offset by 90° (arrows) with regard to previous installation position.

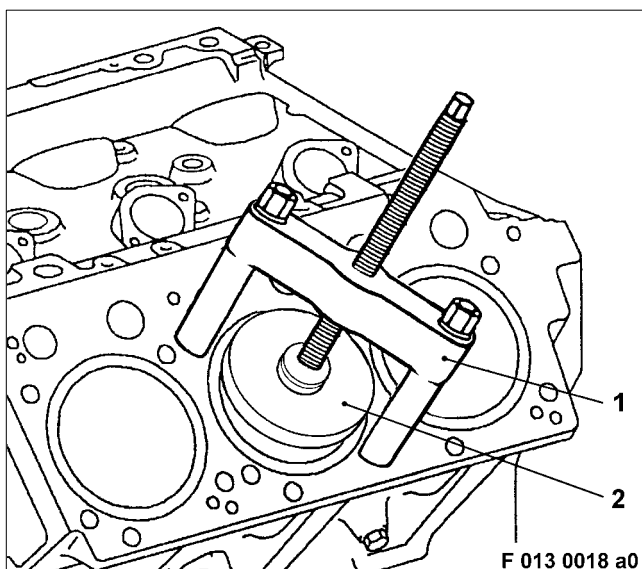

On the opposite side, insert screws of insertion tool (1) into threaded bores for cylinder head screws.

Fit pressure plate (2) on cylinder liner.

Turn spindle in clockwise direction to press cylinder liner into crankcase bore.

Remove installation tool from crankcase.

Note: In order to prevent cylinder liner being released when piston is installed, prepare sleeves and cylinder heads to secure cylinder liners.

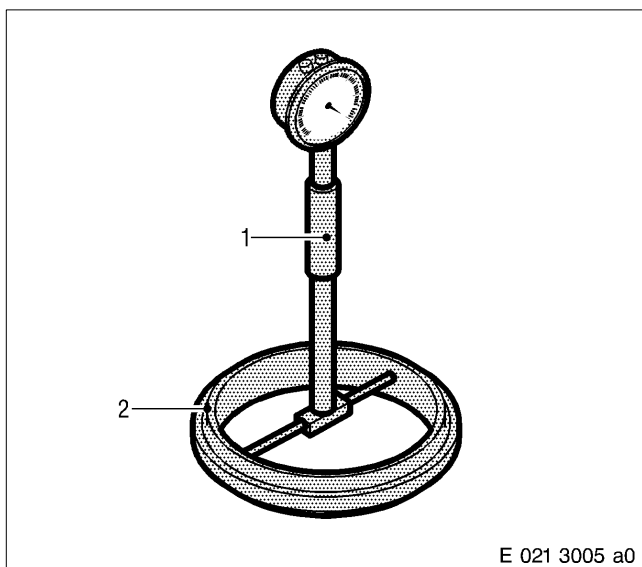

Measuring cylinder liner I.D.

Adjust bore gauge (1) and dial gauge with micrometer or gauge ring (2) to basic size for cylinder liner as per Tolerances and Wear Limits List.

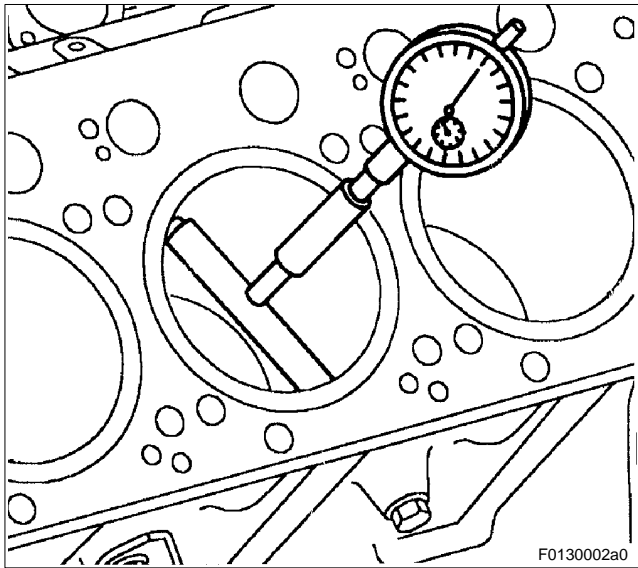

Measuring cylinder liner I.D. with bore gauge.
For measuring points and limit values, see Tolerances and Wear Limits List.
Enter measurement values in data sheet.
Remove cylinder liner if liner is out-of-round.
Check sealing rings are correctly positioned in crankcase and replace.
Clean both grooves in crankcase.

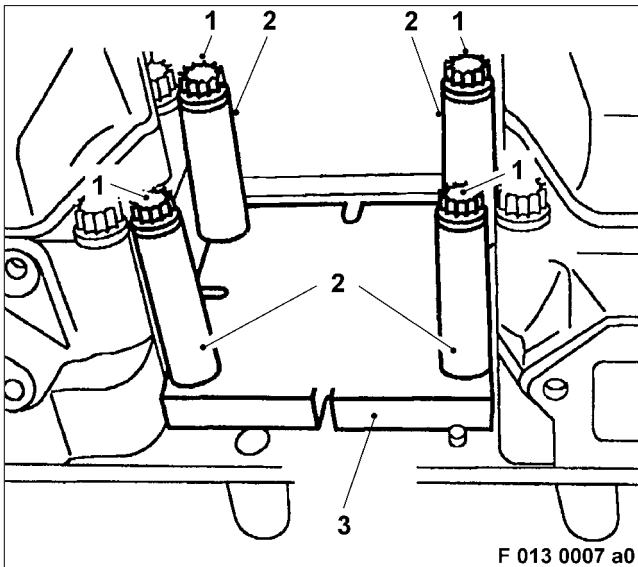

Measuring projection of cylinder liner
Mount measuring plate (3) and spacer tubes (2) with cylinder head screws (1) on cylinder liner.
Tightening torque of cylinder head screws: 50 Nm

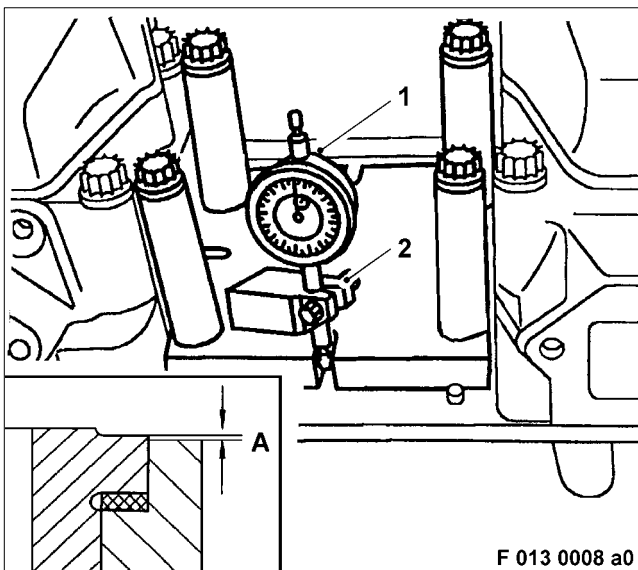

Mount dial gauge (1) with extension on dial gauge holder (2) and, with preload, guide through one of the recesses in measuring plate.
Set dial gauge to "0".
Shift dial gauge with dial gauge holder from cylinder liner collar to crankcase.
Record projection (A).
Measure projection of each recess (4X) in measuring plate.
Set scale of dial gauge to "0" before each measurement.
Difference between 4 measuring points on each cylinder liner must not exceed max. 0.02 mm.
For projection (A), see Tolerances and Wear Limits List.
If the checking measurements deviate, remove cylinder liner and determine cause.
Remove measuring plate and spacer tubes.

C 013.05.12 After-Installation Operations

A distinction must be made as to whether:

- 1 ————— The engine is to be completely disassembled
- 2 ————— The engine is to be removed but not disassembled
- 3 ————— The engine is to remain installed

1	2	3	Operations	See
x	-	-	Perform operations as per Assembly Plan	B 005
x	-	-	Install engine	B 007
-	x	x	Install piston and conrod	C 037.05
-	x	x	Install oil pan	C 014.05
-	x	x	Install cylinder head	C 041.05
-	x	x	Installing pushrods	C 054.05
-	x	x	Installing rocker arm assembly	C 055.05
-	x	x	Adjusting valve clearance	C 055.05.11
-	x	x	Connect leak-off fuel lines	C 086.05
-	x	x	Install H.P. fuel line	C 073.05
-	x	x	Install cylinder head cover	C 055.10
-	x	x	Install exhaust manifold	C 142.05
-	x	x	Install turbocharger	C 101.01
-	x	x	Install charge air manifold	C 124.05
-	x	x	Connect electric cables	-
-	x	x	Install crankcase breather	C 018.10
-	x	x	Install air system before exhaust turbocharger	-
-	-	x	Fill oil system with engine oil	Operating Instructions
-	-	x	Fill engine coolant system	Operating Instructions
-	-	x	Release engine start	Operating Instructions



C 014.05 Oil Pan

C 014.05.01 General View

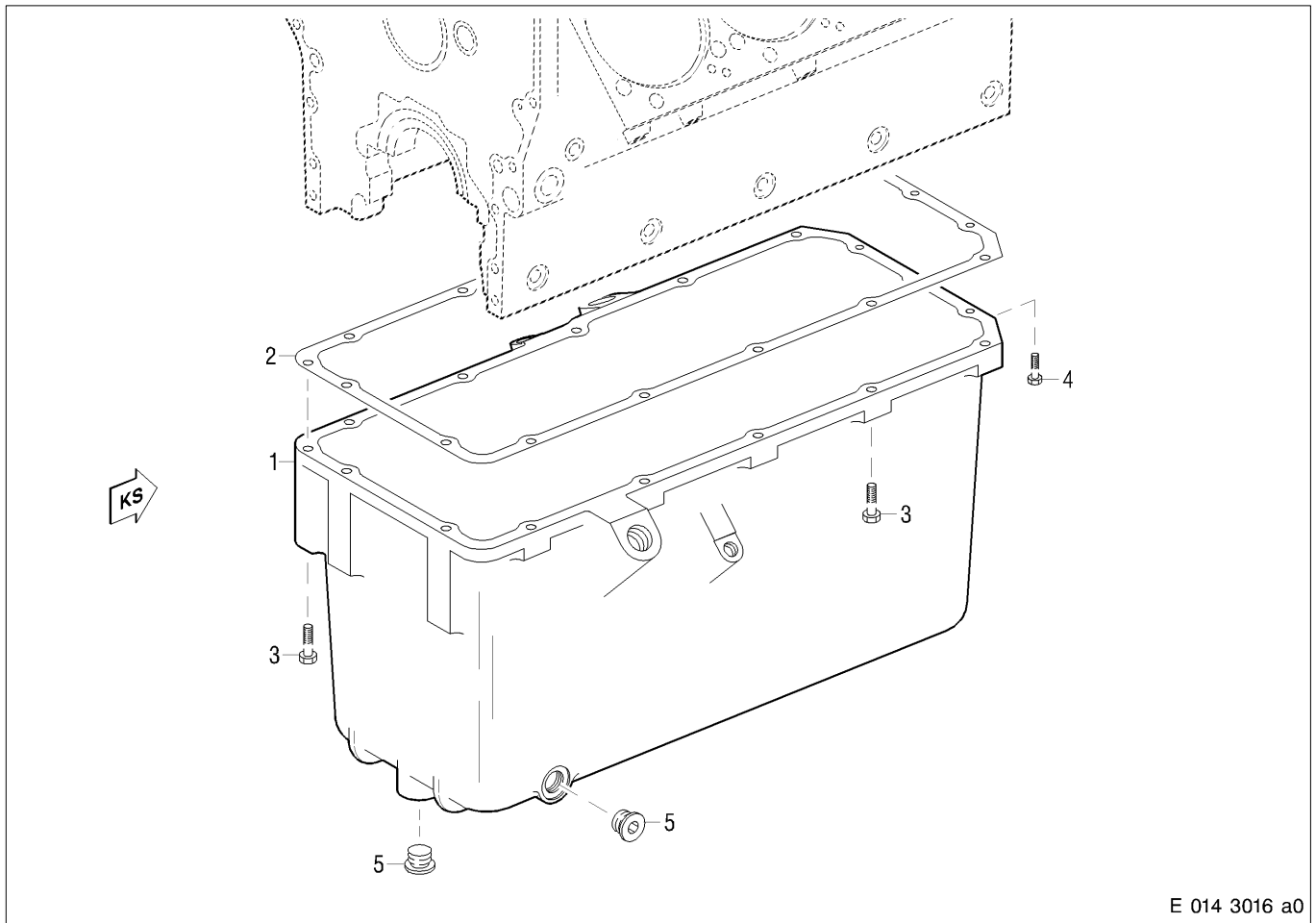

- 1 Oil pan
- 2 Gasket
- 3 Hex screw
- 4 Hex screw
- 5 Blanking plug (with O-ring)

C 014.05.04 Before-Removal Operations

A distinction must be made as to whether:

- 1 ————— The engine is to be completely disassembled
- 2 ————— The engine is to be removed but not disassembled
- 3 ————— The engine is to remain installed

1	2	3	Operations	See
x	—	—	Remove engine	B 003
x	—	—	Perform operations as per Disassembly Plan	B 004
—	—	x	Disable engine start	Operating Instructions
—	—	x	Drain or draw off engine oil	Operating Instructions
—	x	x	Remove guide tube with oil dipstick	C 182.10
—	x	x	Remove oil filler pipe	C 182.10

C 014.05.05 Removal

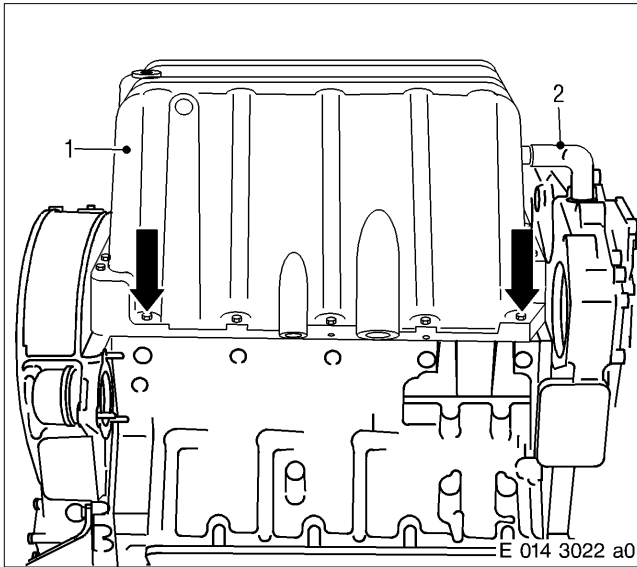

Removing oil pan

Remove elbow (2), see also C 024.05.
Remove all hex screws (arrow) for oil pan.
Carefully lift oil pan and lower onto relevant support.
Remove gasket.

C 014.05.08 Inspection and Repair

Note: Make sure parts are perfectly clean.

Clean oil pan and carefully remove any remaining detergent.

Use red penetrant dye to surface crack-test oil pan.

If cracks are found, replace oil pan.

Check oil pan for damage and wear, repair as necessary or replace.

Check mating face of oil pan with crankcase for surface irregularities.

In event of irregularities over 0.2 mm, recondition mating face.

Check sealing and mating faces for surface irregularities; rub down with oilstone or emery cloth if necessary.

Check threaded bores for ease of movement; replace threaded inserts as necessary – see A 009.

Check condition of securing screws and blanking plugs and check thread for ease of movement; replace component as necessary.

Replace gasket.

C 014.05.11 Installation

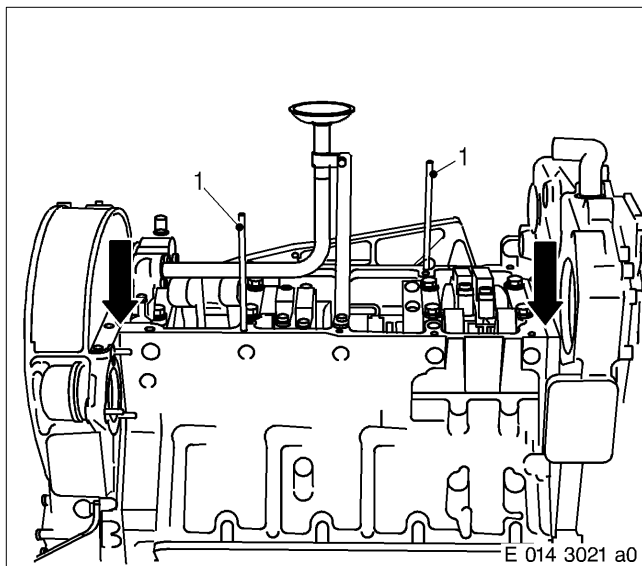

Installing oil pan

Note: Always make sure that all components are perfectly clean.

Clean and degrease mating faces of oil pan and crankcase.

Coat mating face in area of crankcase-flywheel housing and crankcase-gear case partition (arrows) with sealing paste.

Note: Lightly apply sealing paste to the four joints.

Insert two suitable guide pins (1) into two opposing threaded bores of oil pan securing screws.

Position gasket on sealing surface via guide pins.

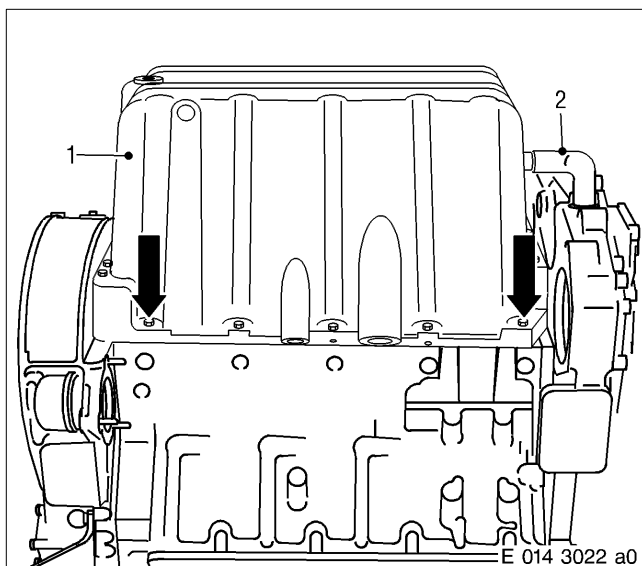

Carefully lower oil pan (1) via guide pins onto crankcase.

Make sure that gasket is correctly seated along its full length.

Remove guide pins.

Insert four corner screws (arrows) for oil pan and tighten diagonally and evenly.

Starting from the most recently tightened corner screw, tighten remaining screws in sequence around circumference.

In same sequence as at start, tighten corner screws diagonally and evenly.

Mount elbow (2) with hose clamps on flange in oil pan and on gear case – also see C 024.05.

Note: Crankcase must not be lowered onto oil pan.
Risk of oil pan breaking!



C 014.05.12 After-Installation Operations

A distinction must be made as to whether:

- 1 — The engine is to be completely disassembled
- 2 — The engine is to be removed but not disassembled
- 3 — The engine is to remain installed

1	2	3	Operations	See
x	—	—	Perform operations as per Assembly Plan	B 005
x	—	—	Install engine	B 007
—	x	x	Install oil filler pipe	C 182.10
—	x	x	Install guide tube with oil dipstick	C 182.10
—	—	x	Fill oil system with engine oil	Operating Instructions
—	—	x	Release engine start	Operating Instructions

C 015.05 Lifting Attachments for Engine and Running Gear

C 015.05.01 General View

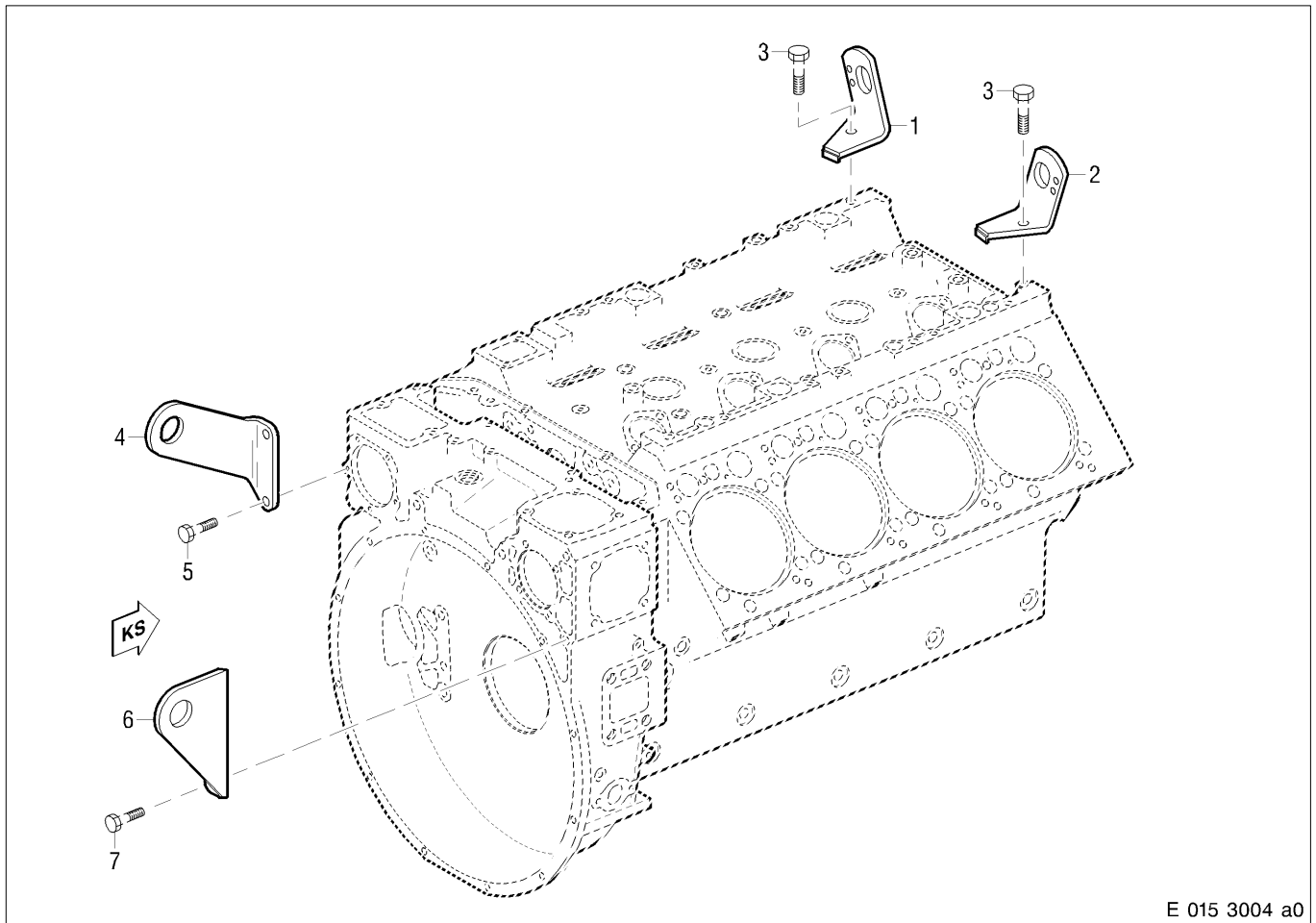

E 015 3004 a0

- | | |
|--------------------------------|--------------------------------|
| 1 Engine lifting device, left | 5 Hex screw |
| 2 Engine lifting device, right | 6 Engine lifting device, right |
| 3 Hex screw | 7 Hex screw |
| 4 Engine lifting device, left | |

C 015.05.04 Before-Removal Operations

A distinction must be made as to whether:

- | | | |
|---|-------|--|
| 1 | _____ | The engine is to be completely disassembled |
| 2 | _____ | The engine is to be removed but not disassembled |
| 3 | _____ | The engine is to remain installed |

1	2	3	Operations	See
x	-	-	Remove engine	B 003
x	-	-	Perform operations as per Disassembly Plan	B 004
-	-	x	Disable engine start	Operating Instructions

C 015.05.05 Removal

Remove engine lifting fixtures

Remove engine lifting device, driving and free end, as shown in General View, See C 015.05.01.

C 015.05.08 Inspection and Repair

Clean all components and visually inspect damage and defects; repair as necessary.

Using the surface crack-testing method with red penetrant dye, check engine lifting device on driving and free ends. lever and connecting element for cracks.

If cracks are detected, replace part.

Check condition of mating faces and/or screw-down surfaces; rub down with oilstone if necessary.

Check thread of securing screws for ease of movement; replace screw as necessary.

C 015.05.11 Installation

Install engine lifting attachments

Install engine lifting device, driving and free end, as shown in General View, See C 015.05.01.

C 015.05.12 After-Installation Operations

A distinction must be made as to whether:

- 1 ————— The engine is to be completely disassembled
- | 2 ————— The engine is to be removed but not disassembled
- | | 3 — The engine is to remain installed

1	2	3	Operations	See
x	-	-	Perform operations as per Assembly Plan	B 005
x	-	-	Install engine	B 007
-	-	x	Release engine start	Operating Instructions

C 018.10 Crankcase Ventilation

C 018.10.01 General View

Oil separator

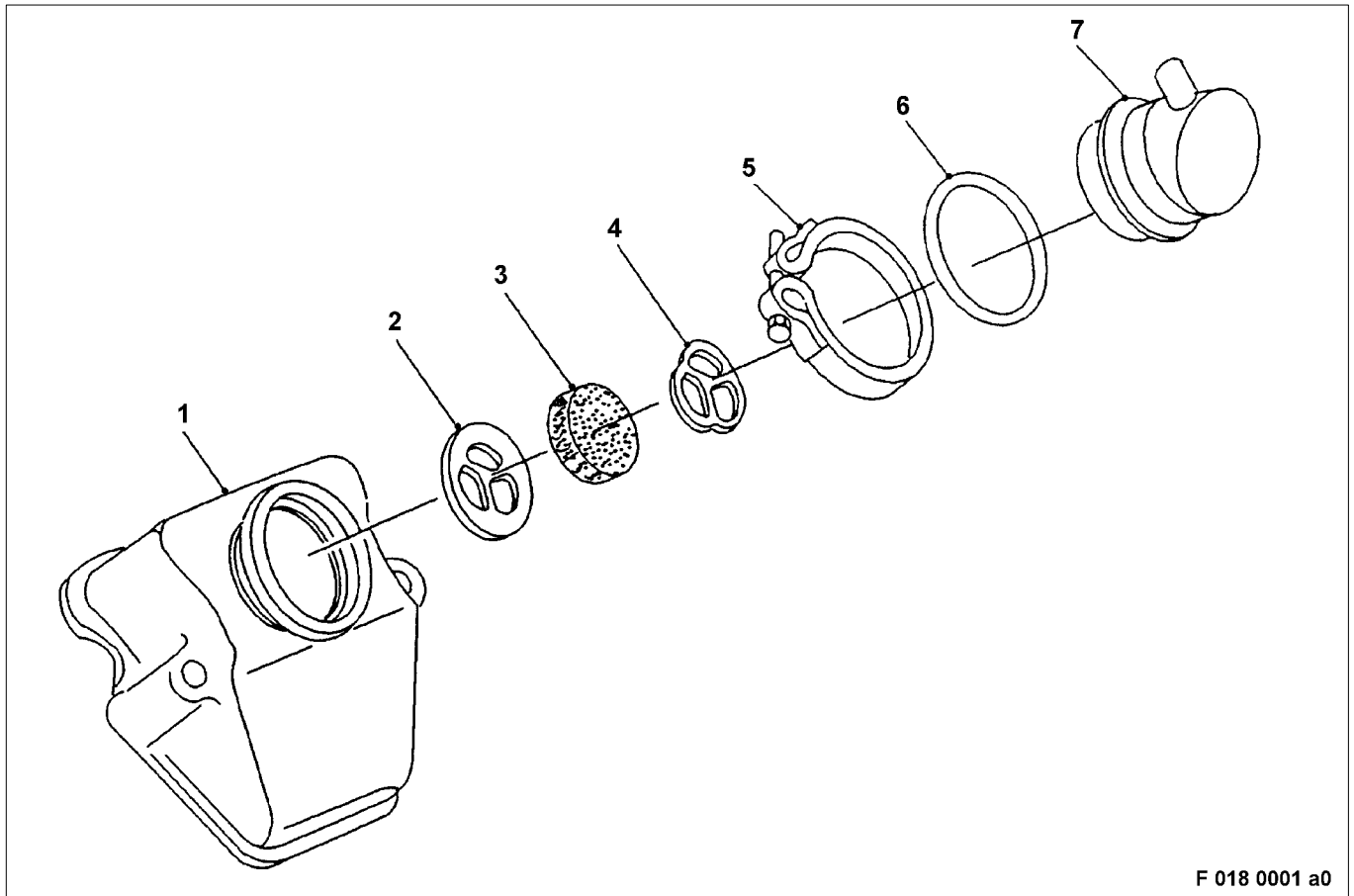

F 018 0001 a0

- | | | | |
|---|---------------------|---|-----------------------|
| 1 | Cylinder head cover | 5 | Clamp |
| 2 | Bracket | 6 | Sealing ring |
| 3 | Insert | 7 | Oil separator housing |
| 4 | Bracket | | |

C 018.10.04 Before-Removal Operations

A distinction must be made as to whether:

- 1 — The engine is to be completely disassembled
- 2 — The engine is to be removed but not disassembled
- 3 — The engine is to remain installed

1	2	3	Operations	See
x	—	—	Remove engine	B 003
x	—	—	Perform operations as per Disassembly Plan	B 004
—	—	x	Disable engine start	Operating Instructions
—	x	x	Cylinder head cover removal	C 055.10

C 018.10.05 Removal

Removing oil separator

Remove securing clamp and remove oil separator as shown in General View – see C 055.10.01.
Remove individual components from oil separator.

C 018.10.08 Inspection and Repair

Note: Make sure parts are perfectly clean.

Clean all components.

Visually inspect components for damage and wear; replace components as necessary.



WARNING

Fuels and fuel vapours are flammable and poisonous. Risk of fire, explosions and poisoning! When using fuel: – do not use naked flame – no electric sparks – do not smoke – do not spill fuel Do not inhale. Always wear protective gloves and protective goggles/safety mask. Ventilate working area well.

Wash out insert in diesel fuel.



CAUTION

Compressed air is air which has been compressed under pressure. If compressed air is used for blowing out or blow-drying components, always wear protective goggles or safety mask. Compressed air must not be directed at the body.

Blow out insert with compressed air.

Replace sealing ring.

C 018.10.11 Installation

Installing oil separator

Note: Make sure parts are perfectly clean.

Check sealing surface on cylinder head cover and oil separator housing; clean as necessary.

Coat new sealing ring with petroleum jelly and insert into groove in oil separator housing.

In correct sequence, insert bracket and insert into oil separator housing as shown in General View – see C 018.10.01.

Mount oil separator with securing clamp on cylinder head cover.

Note: Mount suction hose on oil separator free of tension.

C 018.10.12 After-Installation Operations

A distinction must be made as to whether:

- 1 ————— The engine is to be completely disassembled
- | 2 ————— The engine is to be removed but not disassembled
- | | 3 — The engine is to remain installed
- | | |

1	2	3	Operations	See
x	-	-	Perform operations as per Assembly Plan	B 005
x	-	-	Install engine	B 007
-	x	x	Install cylinder head cover	C 055.10
-	-	x	Release engine start	Operating Instructions



Contents

C 020	Gear Train
C 021.05	Flywheel housing
C 021.05.01	General view
C 021.05.04	Before-removal operations
C 021.05.05	Removal
C 021.05.06	Disassembly
C 021.05.08	Inspection and repair
C 021.05.10	Assembly
C 021.05.11	Installation
C 021.05.12	After-installation operations
C 022.05	Gear Train, driving end
C 022.05.01	General view
C 022.05.04	Before-removal operations
C 022.05.05	Removal
C 022.05.08	Inspection and repair
C 022.05.11	Installation
C 022.05.12	After-installation operations
C 024.05	Gear Case, free end
C 024.05.01	General view
C 024.05.02	Special tool
C 024.05.04	Before-removal operations
C 024.05.05	Removal
C 024.05.08	Inspection and repair
C 024.05.11	Installation
C 024.05.12	After-installation operations
C 025.05	Gear Train, free end
C 025.05.01	General view
C 025.05.02	Special tool
C 025.05.04	Before-removal operations
C 025.05.05	Removal
C 025.05.08	Inspection and repair
C 025.05.11	Installation
C 025.05.12	After-installation operations

C 028.05 Belt drive

- C 028.05.01 General view
- C 028.05.02 Special tool
- C 028.05.04 Before-removal operations
- C 028.05.05 Removal
- C 028.05.08 Inspection and repair
- C 028.05.11 Installation
- C 028.05.12 After-installation operations

C 020 Gear Train

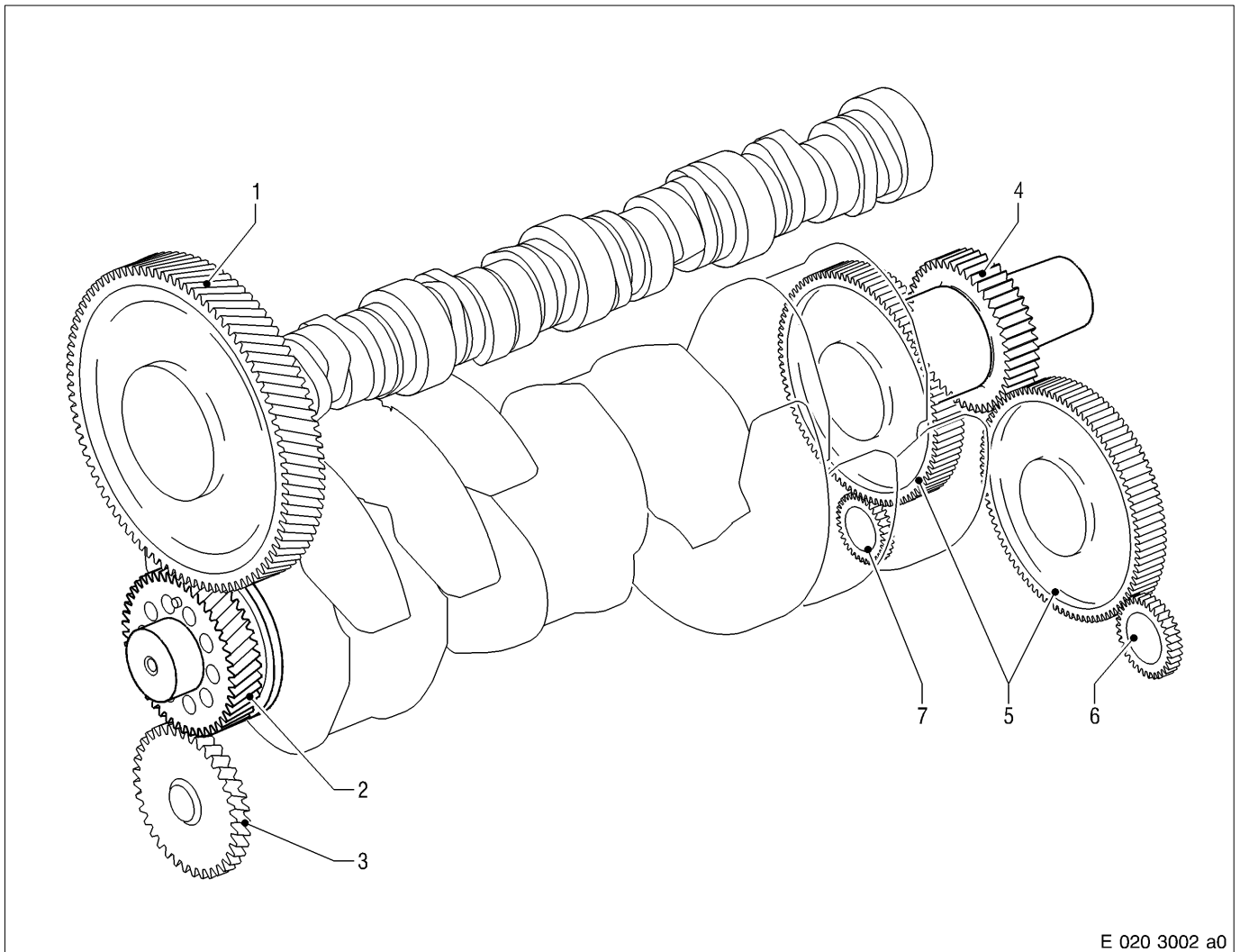

E 020 3002 a0

		Tooth backlash (mm)	Axial clearance (mm)
1	Camshaft gear	from 0.20 to 0.50 for gear 6	from 0.20 to 0.55 (camshaft)
2	Crankshaft gear, driving end	–	–
3	Drive gear (oil pump)	from 0.04 to 0.32 for gear 6	–
4	Crankshaft gear, free end	–	–
5	Idler gear	from 0.04 to 0.32 for gear 2	from 0.05 to 0.95
6	Drive gear (engine coolant pump)	from 0.04 to 0.32 for gear 3	–
7	Gear (Charge air coolant pump)*	from 0.20 to 0.50 for gear 3	–

* – not always applicable (order-specific) –

The following is a list of auxiliary equipment and materials needed for the assembly operations:

!	CAUTION
When using these chemical substances, it is essential to observe the manufacturer's instructions for use, safety instructions and waste disposal specifications.	

Materials and consumables	Designation	Order No.		Remarks
		MTU	DDC	
Emery cloth				
Bottle brush				
Magnifying glass				
Liquid nitrogen				
Vaseline	Petroleum jelly, white	40317		
Corrosion preventive	Caramba Express	40008		
Activator	Loctite No. 7649	50548		
Surface sealant	Loctite No. 573	40031		Final strength ≈ 48 h
Thread-locking compound	Loctite No. 270	40083		Final strength at 20 °C ≈ 12 h
Multipurpose grease	Shell Retinax	40333		
Engine oil				
Cleaning agent	Solvclean KW	40022		
Kerosene or diesel fuel				
Denaturated ethanol		40250		
Sealing paste	Elastosil N 189	50545		
Engineer's blue	blue	40641		
Dry compressed air				
Magnetic crack-testing equipment with fluorescent magnetic powder				
Surface crack-testing equipment with red penetrant dye				

C 021.05 Flywheel Housing

C 021.05.01 General View

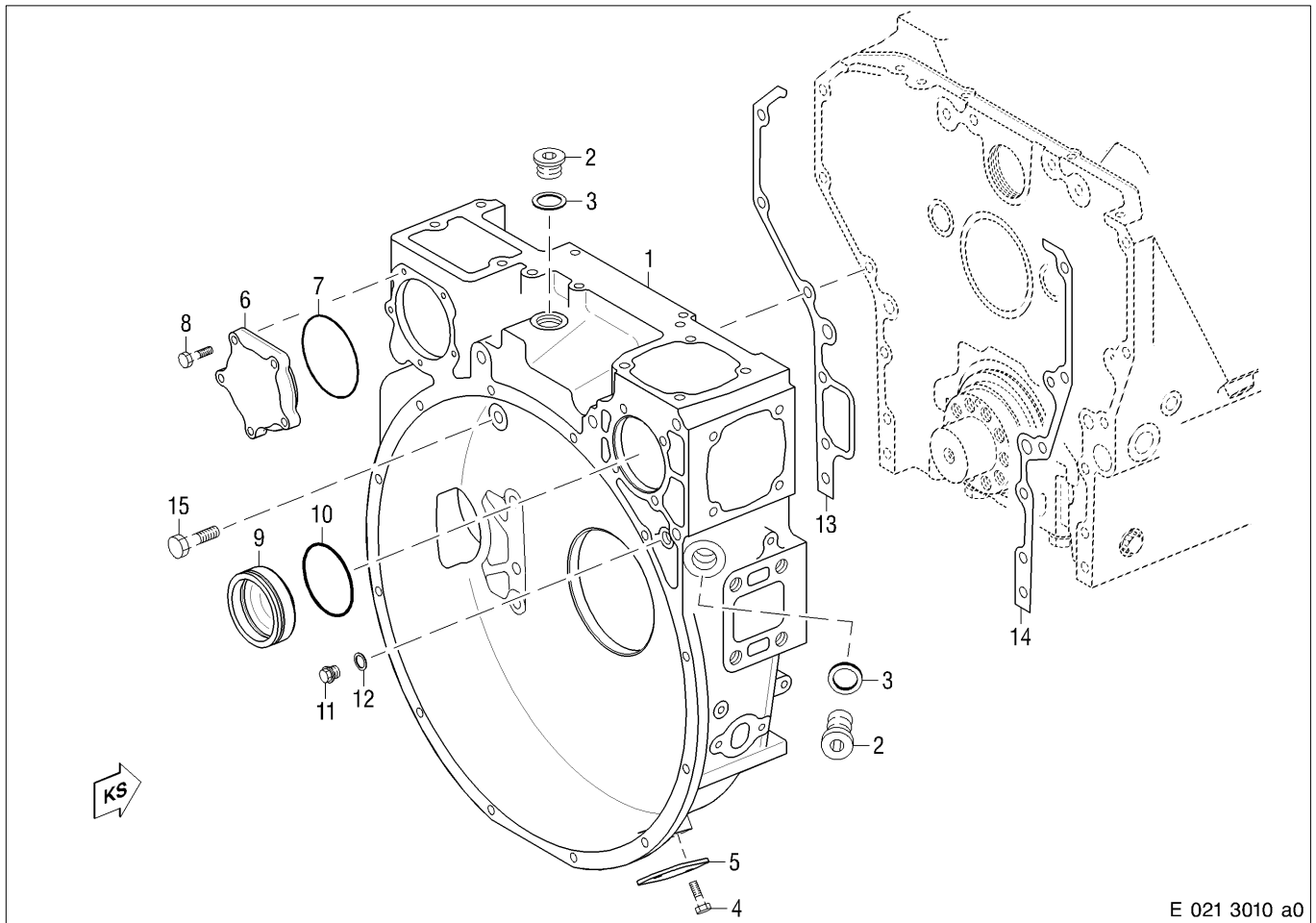

- 1 Flywheel housing
- 2 Plug
- 3 Sealing ring
- 4 Hex screw
- 5 Cover
- 6 End cover

- 7 O-ring
- 8 Hex screw
- 9 End cover
- 10 O-ring
- 11 Plug
- 12 Sealing ring

- 13 Gasket
 - 14 Gasket
 - 15 Double-hex screw
- Tightening torque: 100 Nm
Lubricant: Engine oil

Flywheel housing

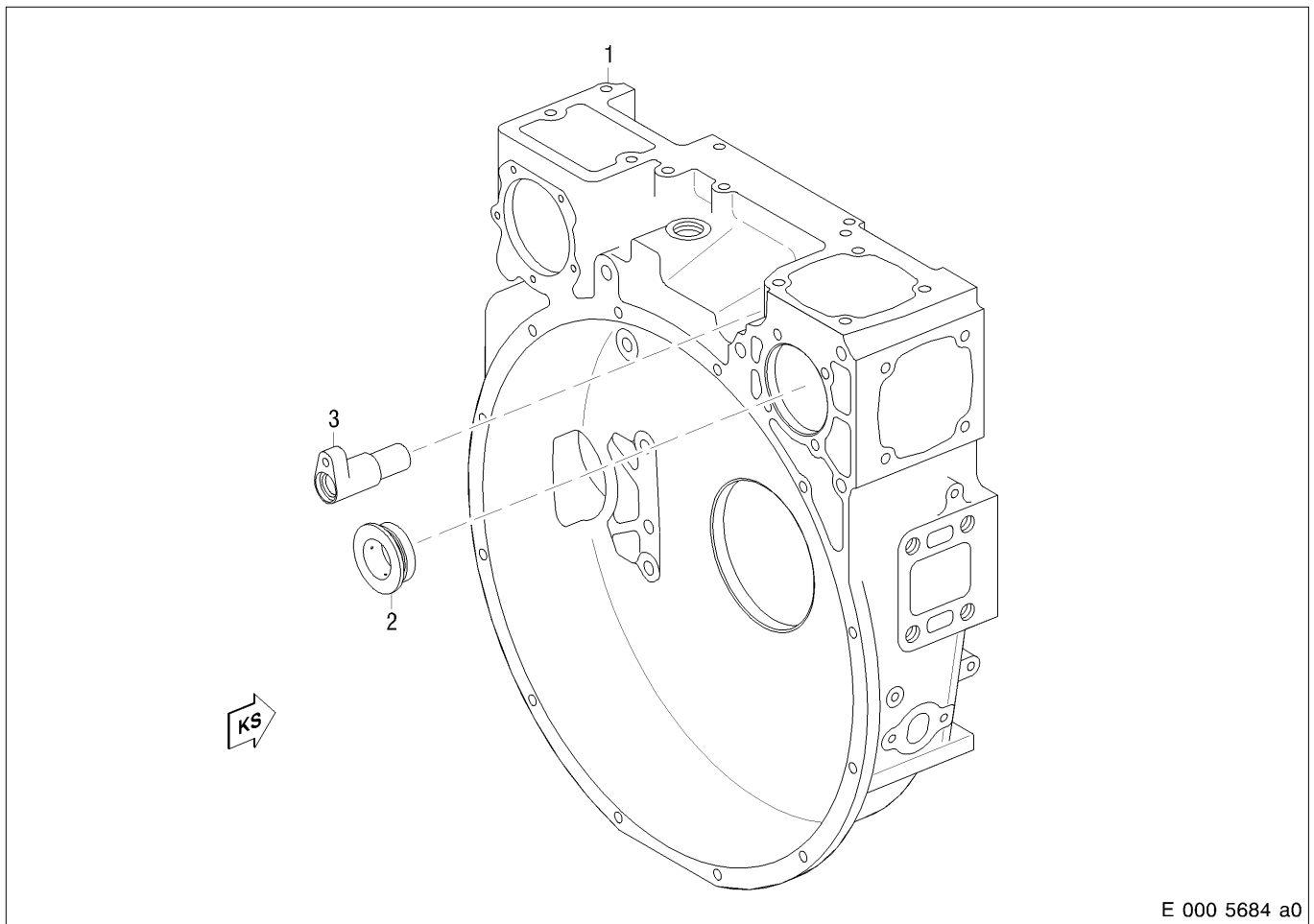

- 1 Flywheel housing
- 2 Auxiliary PTO bearing
- 3 Sensor retainer

C 021.05.04 Before-Removal Operations

A distinction must be made as to whether:

- 1 ————— The engine is to be completely disassembled
- 2 ————— The engine is to be removed but not disassembled
- 3 ————— The engine is to remain installed

1	2	3	Operations	See
x	–	–	Remove engine	B 003
x	–	–	Perform operations as per Disassembly Plan	B 004
–	–	x	Disable engine start	Operating Instructions
–	–	x	Drain engine coolant	Operating Instructions
–	–	x	Drain or draw off engine oil	Operating Instructions
–	–	x	Separate engine from gearbox or alternator	–
–	x	x	Remove coolant lines	C 202.15
–	x	x	Remove oil supply lines for turbochargers	C 185.10
–	x	x	Remove oil return lines for turbochargers	C 185.25
–	x	x	Remove intercooler	C 111.05
–	x	x	Remove coupling	Special Publication
–	x	x	Removing flywheel	C 032.05
–	x	x	Remove starter	C 172.05
–	x	x	Remove speed sensor	Special Publication
–	x	x	Attach engine to lifting device	–
–	x	x	Remove engine mount, driving end	–
–	x	x	Lower or remove oil pan	C 014.05

C 021.05.05 Removal

Removing flywheel housing

Remove engine lifting device, driving end – see C 015.05.

Remove double-hex screws for flywheel housing as shown in General View – see 021.05.01.

Carefully press flywheel housing in direction of driving end until it is released from dowel pins in crankcase.

Remove gaskets from flywheel housing and/or crankcase.

If necessary, cover opening on oil pan.

C 021.05.06 Disassembly

Disassembling flywheel housing

Remove cover and plugs as shown in General View – see C 021.05.01.

Remove O-rings and sealing rings.

Remove radial-lip shaft seal – see C 032.05.

Using suitable extractor, remove bearing for auxiliary drive and bracket for sensor from flywheel housing only if necessary (e.g. if damaged).

Note: Retainer for sensor is secured with thread-locking agent and, before removal, must be heated to approx. 200 °C.

C 021.05.08 Inspection and Repair

Clean all components and visually inspect damage and defects; repair as necessary.

Check flywheel housing for cracks using surface crack-testing method with red penetrant dye. Replace if cracks are detected.

Thoroughly clean oilways and bores in flywheel housing and check that they are perfectly clean.

Check threads and shanks of double hex screws for damage; replace screws as necessary.

Check all mating and sealing faces and fits. Rub down with oilstone or emery cloth as necessary.

Check studs, replace as required.

Check thread in flywheel housing for ease of movement; replace thread insert if necessary.

Replace seals, sealing rings and O-rings.

C 021.05.10 Assembly

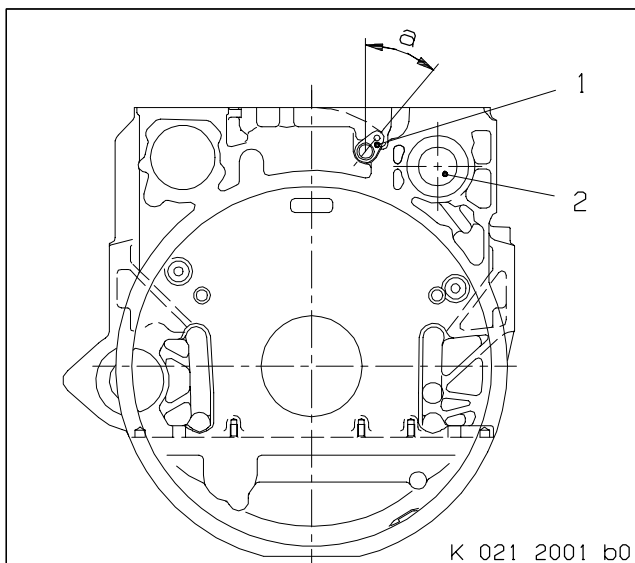

Complete flywheel housing

CAUTION

Nitrogen is liquid at –200 °C (–328 F). Danger of freezing and suffocation!
Do not allow liquid nitrogen to come into contact with parts of body (eyes, hands).
Wear protective clothing (including gloves and closed shoes) and goggles.
Ventilate working area well.

Chill auxiliary drive bearing (2) in liquid nitrogen.

Insert auxiliary drive bearing into bore in flywheel housing until the stop, ensuring that position of lube oil bores is correct.

Make sure that lube oil bore is perfectly clean and unobstructed.

Dry-clean and degrease bore in flywheel housing and mating faces on sensor retainer (1).

Coat mating faces on sensor retainer with thread-locking agent.

Using a manual press, insert sensor retainer into bore in flywheel housing until the stop; in doing so, hold bracket (a) in position.

a = from 40° to 44°

Install cover as shown in General View, see C 021.05.01.

Coat O-rings with petroleum jelly before installing.

Install radial-lip shaft seal – see C 032.05.

C 021.05.11 Installation

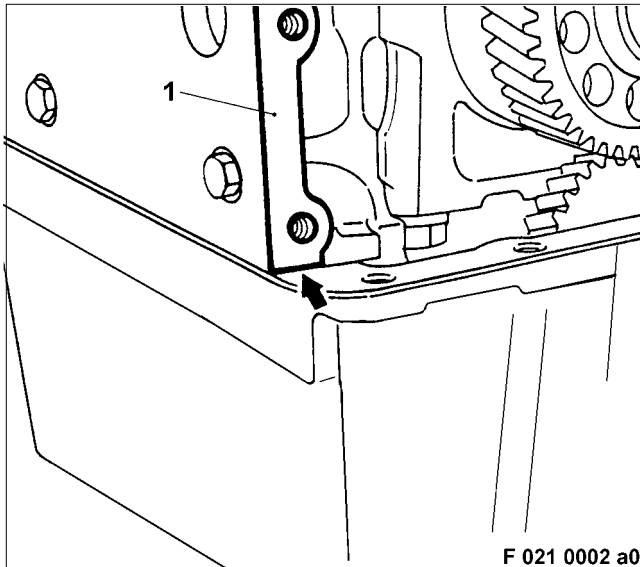

Installing flywheel housing

Note: Make sure that oil bores and oil chambers are perfectly clean.

Clean mating face on crankcase and on flywheel housing.

To secure position of gaskets (1), apply a thin, dotted coat of sealing paste to mating face of crankcase.

Insert two suitable guide pins into crankcase.

Fit new gaskets on crankcase via guide pins and dowel pins.

Adjust length of gaskets (arrow).

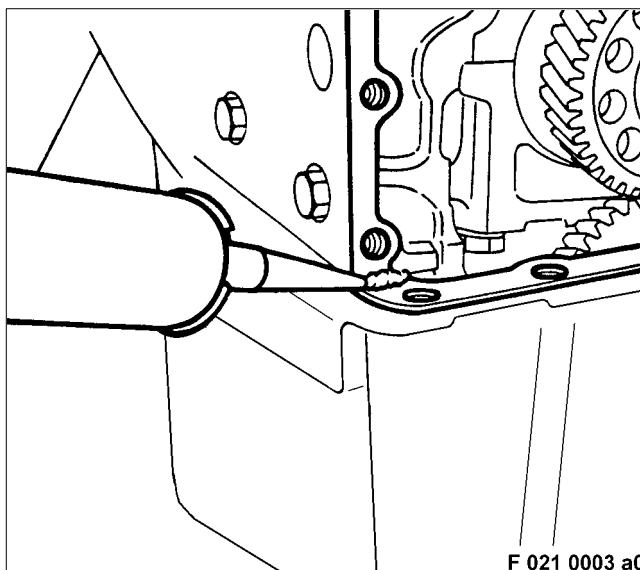

Coat partition surfaces between flywheel housing gasket and oil pan with a thin film of sealing paste.

Note: Wipe off excess sealing paste!

Mount flywheel housing via guide pins on crankcase with double-hex screws.

Check that dowel pin engagement is correct.

Tighten double-hex bolts to specified tightening torque – see C 021.05.01.

Mount engine lifting device, driving end – see C 015.05.

Measure axial play of camshaft – see C 051.05.11.



C 021.05.12 After-Installation Operations

A distinction must be made as to whether:

- 1 ————— The engine is to be completely disassembled
- 2 ————— The engine is to be removed but not disassembled
- 3 ————— The engine is to remain installed

1	2	3	Operations	See
x	-	-	Perform operations as per Assembly Plan	B 005
x	-	-	Install engine	B 007
-	x	x	Install oil pan	C 014.05
-	x	x	Install engine mount, driving end	-
-	x	x	Install intercooler	C 111.05
-	x	x	Connect coolant lines	C 202.15
-	x	x	Install oil supply lines for turbochargers	C 185.10
-	x	x	Install oil return lines for turbochargers	C 185.25
-	x	x	Install flywheel	C 032.05
-	x	x	Install starter	C 172.05
-	x	x	Install speed sensor	-
-	x	x	Install coupling	Special Publication
-	-	x	Fill oil system with engine oil	Operating Instructions
-	-	x	Fill engine coolant system	Operating Instructions
-	-	x	Check engine alignment; realign engine if necessary	Special Publication
-	-	x	Connect engine with gearbox/alternator	-
-	-	x	Release engine start	Operating Instructions

C 022.05 Gear Train, Driving End

C 025.05.01 General View

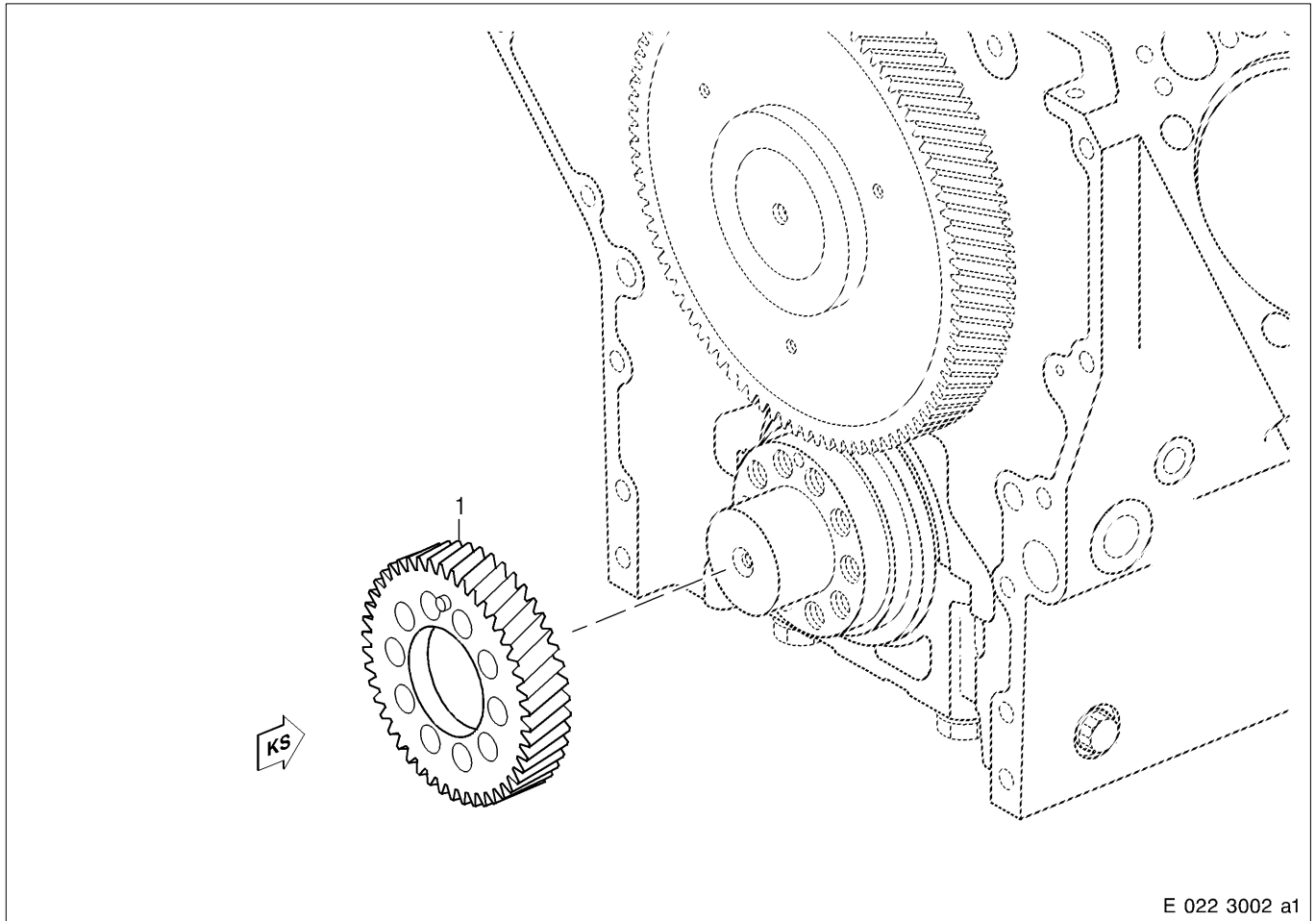

1 Crankshaft gear, driving end

C 022.05.04 Before-Removal Operations

A distinction must be made as to whether:

- 1 ————— The engine is to be completely disassembled
- 2 ————— The engine is to be removed but not disassembled
- 3 ————— The engine is to remain installed

1	2	3	Operations	See
x	-	-	Remove engine	B 003
x	-	-	Perform operations as per Disassembly Plan	B 004
-	-	x	Disable engine start	Operating Instructions
-	-	x	Drain engine coolant	Operating Instructions
-	-	x	Drain or draw off engine oil	Operating Instructions
-	-	x	Separate engine from gearbox or alternator	-
-	x	x	Remove coolant lines	C 202.15
-	x	x	Remove oil supply lines for turbochargers	C 185.10
-	x	x	Remove oil return lines for turbochargers	C 185.25
-	x	x	Remove intercooler	C 111.05
-	x	x	Remove coupling	Special Publication Publication
-	x	x	Removing flywheel	C 032.05
-	x	x	Remove starter	C 172.05
-	x	x	Remove speed sensor	Special Publication Publication
-	x	x	Attach engine to lifting device.	-
-	x	x	Remove engine mount, driving end	-
-	x	x	Lower or remove oil pan	C 014.05
-	x	x	Removing flywheel housing	C 021.05

C 022.05.05 Removal

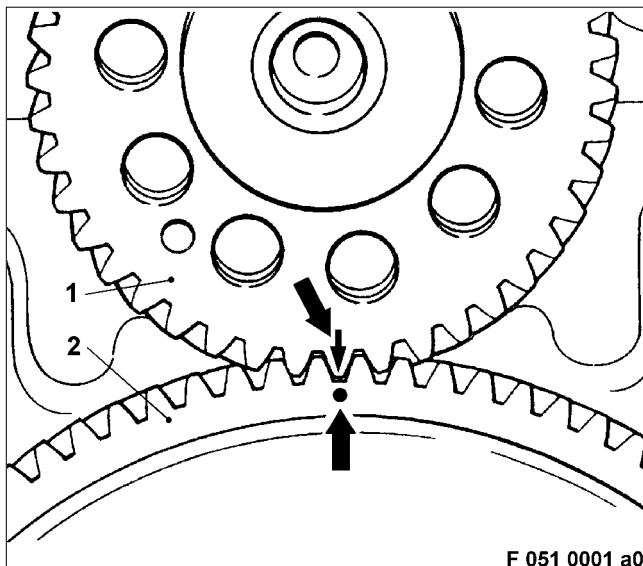

Removing crankshaft gear, driving end

Bar engine with barring tool until markings (arrows) on crankshaft gear, driving end (1) and on camshaft gear (2) are aligned.

Remove the crankshaft gear, driving end, from the crankshaft.

Pay special attention to fit of crankshaft gear dowel pin with regard to crankshaft.

C 022.05.08 Inspection and Repair

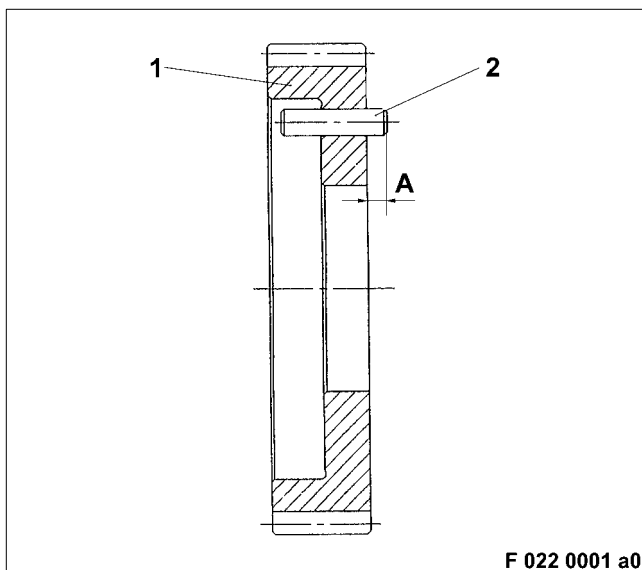

F 022 0001 a0

Checking crankshaft gear, driving end

Clean crankshaft gear (1).

Using the magnetic crack-testing method with fluorescent magnetic powder, check crankshaft gear for cracks; replace crankshaft gear if necessary.

Check tooth flanks, mating faces and bores of crankshaft gear for scoring, wear and indentations.

Remove minor wear, indentations and scoring by rubbing down with emery cloth or an oilstone; replace crankshaft gear if necessary.

Check condition of dowel pin (2), replace as necessary.

Measure projection (A) of dowel pin and retighten with manual press if necessary.

$A = 6 \text{ mm} \pm 0.4 \text{ mm}$

C 022.05.11 Installation

Note: Make sure all components are perfectly clean.

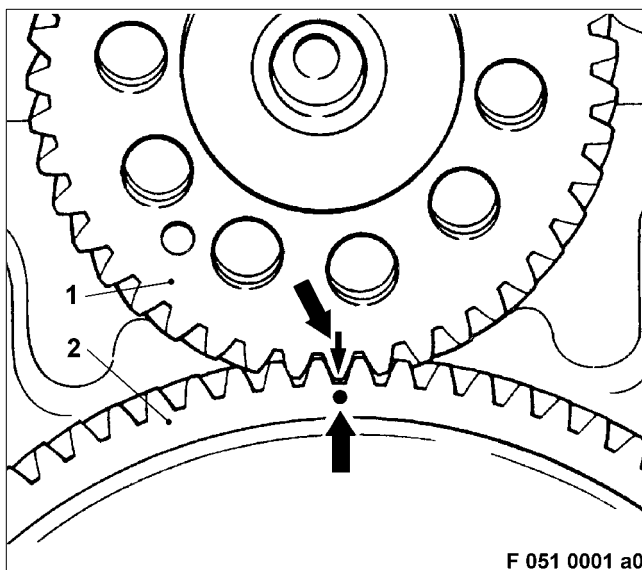

F 051 0001 a0

Installing crankshaft gear, driving end

Fit crankshaft gear, driving end, (1) on crankshaft; pay special attention to fit of crankshaft gear dowel pin with regard to crankshaft.

When installing crankshaft gear, driving end, with camshaft installed, ensure that markings (arrows) on crankshaft gear and camshaft gear (2) are aligned.

Check camshaft timing – see C 051.05.



C 022.05.12 After-Installation Operations

A distinction must be made as to whether:

- 1 ————— The engine is to be completely disassembled
- 2 ————— The engine is to be removed but not disassembled
- 3 ————— The engine is to remain installed

1	2	3	Operations	See
x	-	-	Perform operations as per Assembly Plan	B 005
x	-	-	Install engine	B 007
-	x	x	Install oil pan	C 014.05
-	x	x	Installing flywheel housing	C 021.05
-	x	x	Install engine mount, driving end	-
-	x	x	Install intercooler	C 111.05
-	x	x	Connect coolant lines	C 202.15
-	x	x	Install oil supply lines for turbochargers	C 185.10
-	x	x	Install oil return lines for turbochargers	C 185.25
-	x	x	Install flywheel	C 032.05
-	x	x	Install starter	C 172.05
-	x	x	Install speed sensor	Special Publication
-	x	x	Install coupling	Special Publication
-	-	x	Fill oil system with engine oil	Operating Instructions
-	-	x	Fill engine coolant system	Operating Instructions
-	-	x	Check engine alignment; realign engine if necessary	Special Publication
-	-	x	Connect engine with gearbox/alternator	-
-	-	x	Release engine start	Operating Instructions

C 024.05 Gear Case, Free End

C 024.05.01 General View

Gear case cover

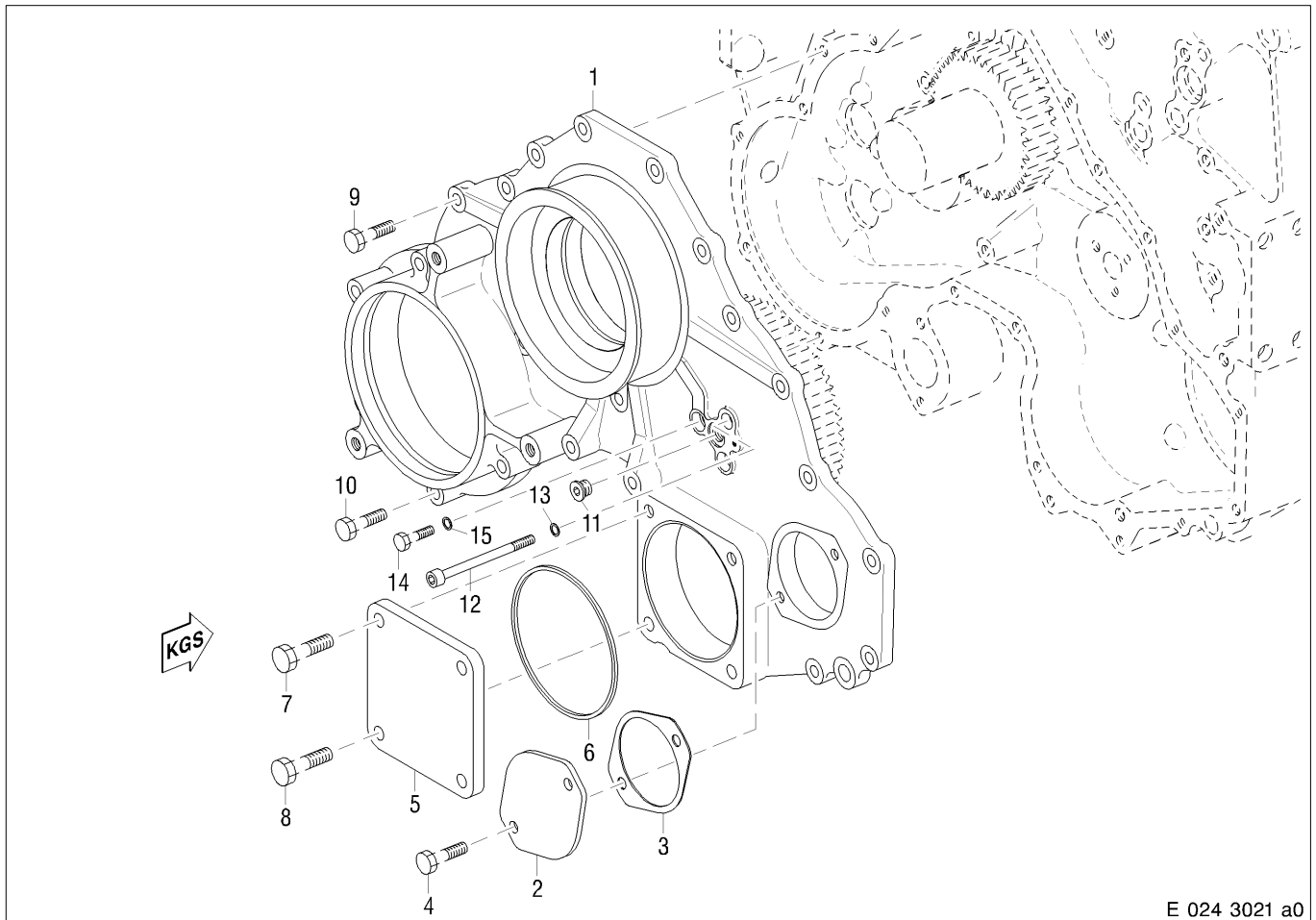

E 024 3021 a0

- | | | |
|-------------------|----------------|----------------------|
| 1 Gear case cover | 6 Sealing ring | 11 Plug |
| 2 Cover | 7 Hex screw | 12 Socket-head screw |
| 3 Gasket | 8 Hex screw | 13 Sealing ring |
| 4 Hex screw | 9 Hex screw | 14 Hex screw |
| 5 Cover | 10 Hex screw | 15 Gasket |

Gear case

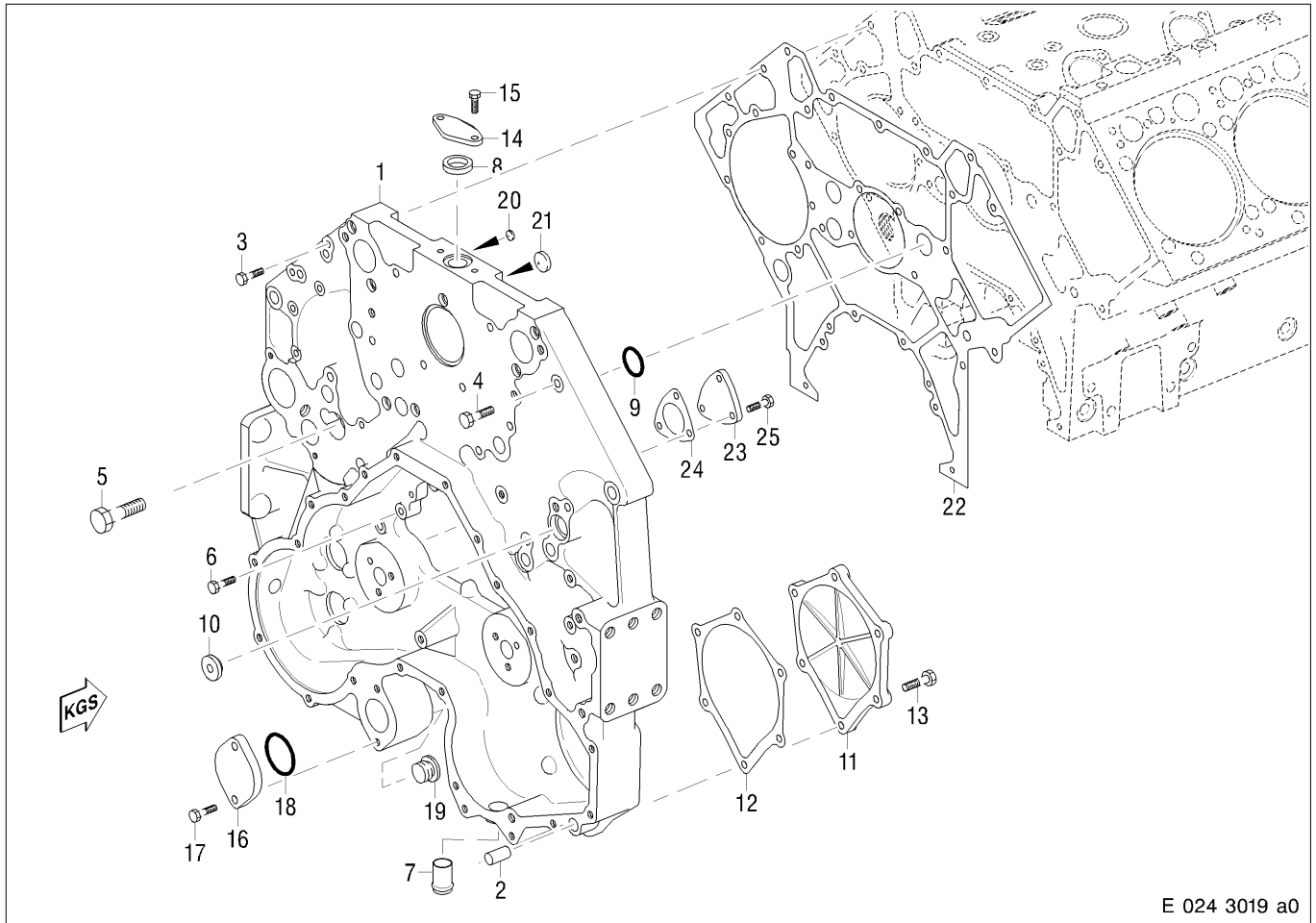

E 024 3019 a0

- | | | |
|----------------------------------|----------------|-----------------|
| 1 Gear case | 9 Sealing ring | 18 Sealing ring |
| 2 Dowel pin | 10 Washer | 19 Plug |
| 3 Hex screw | 11 Cover | 20 Plug |
| 4 Hex screw | 12 Gasket | 21 Plug |
| 5 Hex screw | 13 Hex screw | 22 Gasket |
| 6 Hex screw | 14 Cover | 23 Cover |
| 7 Pipe | 15 Hex screw | 24 Gasket |
| Lubricant: Thread-locking liquid | 16 Cover | 25 Hex screw |
| 8 O-ring | 17 Hex screw | |

Oil return to oil pan (gear case – oil pan)

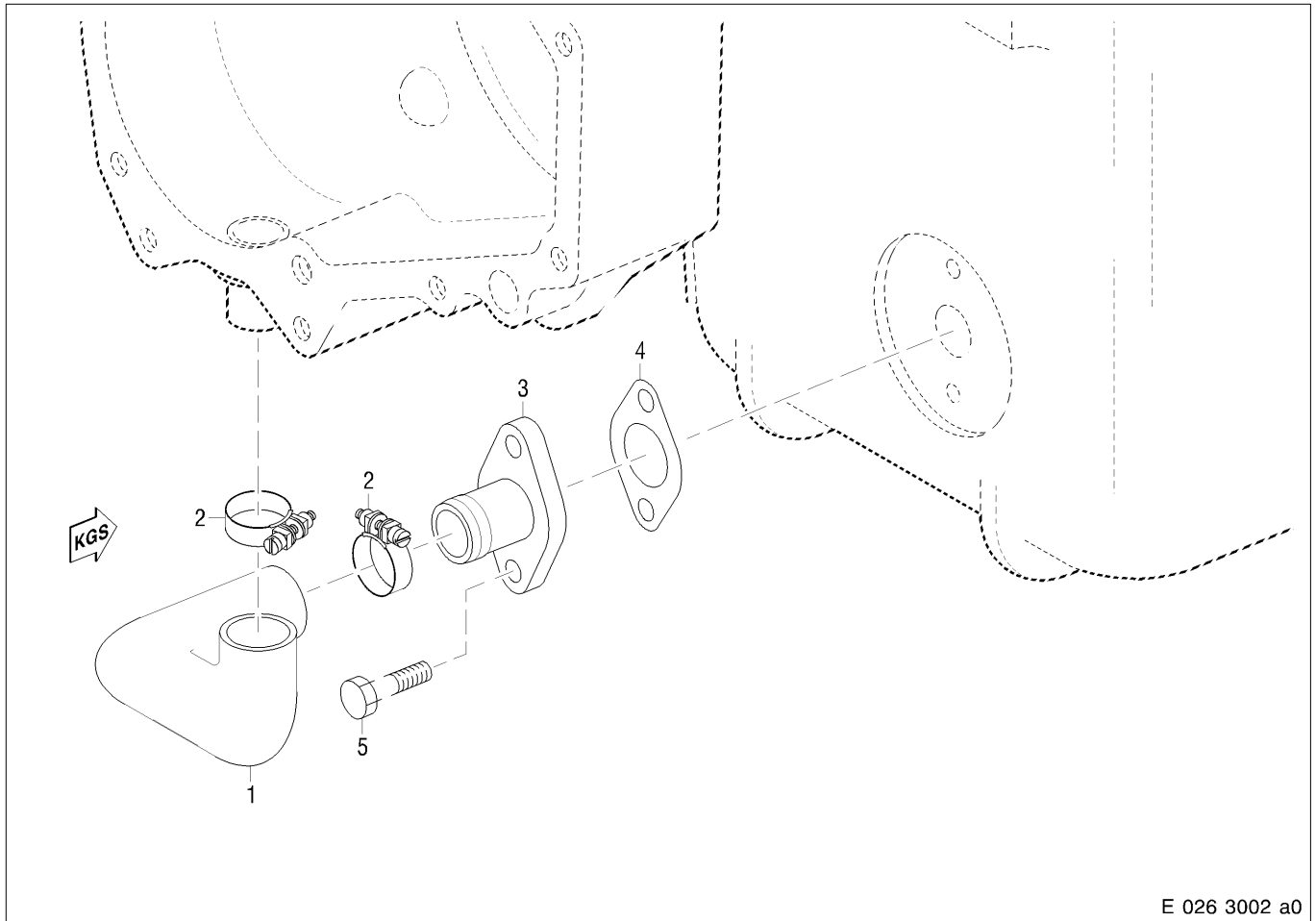

- 1 Elbow
- 2 Clamp
- 3 Flange

- 4 Gasket
- 5 Hex screw

C 024.05.02 Special Tool

Designation – Application	Number
Alignment tool for gear case cover	1
Press-in mandrel for shaft seal	1
Mandrel for end cover	1

C 024.05.04 Before-Removal Operations

A distinction must be made as to whether:

- 1 ————— The engine is to be completely disassembled
- 2 ————— The engine is to be removed but not disassembled
- 3 ————— The engine is to remain installed

1	2	3	Operations	See
x	–	–	Remove engine	B 003
x	–	–	Perform operations as per Disassembly Plan	B 004
–	–	x	Disable engine start	Operating Instructions
–	–	x	Drain engine coolant	Operating Instructions
–	–	x	Drain or draw off engine oil	Operating Instructions
–	x	x	Disconnect fuel lines	C 082.05/C 084.05
–	x	x	Disconnect electric wiring	–
–	x	x	Remove fuel delivery pump	C 081.05
–	x	x	Remove fuel duplex filter	C 083.05
–	x	x	Remove V-belt	C 028.05
–	x	x	Remove fan drive*	C 221.05
–	x	x	Remove coolant lines	C 202.15
–	x	x	Remove engine coolant pump	C 202.05
–	x	x	Remove charge air coolant pump	–
–	x	x	Remove vibration damper	C 035.05
–	x	x	Remove flange, free end	C 035.05
–	x	x	Remove oil lines	C 181.20
–	x	x	Remove air compressor*	C 362.40
–	x	x	Remove generator	C 213.05
–	x	x	Remove coolant pipework housing	C 206.05
–	x	x	Attach engine to lifting device.	–
–	x	x	Remove engine mounting, free end	C 231.05
–	x	x	Lower or remove oil pan	C 014.05

* – not always applicable (order-specific) –

C 024.05.05 Removal

Removing gear case cover

Mark all screws (different lengths) and unscrew as shown in General View – see C 024.05.01.

Secure gear case cover from falling down and, using an assembly lever, carefully press the cover off the gear case press while keeping an eye on the dowel pin fit.

If necessary, use a suitable mandrel and hammer to remove shaft seal from gear case cover.

Remove intermediate gears and axles, see C 025.05.

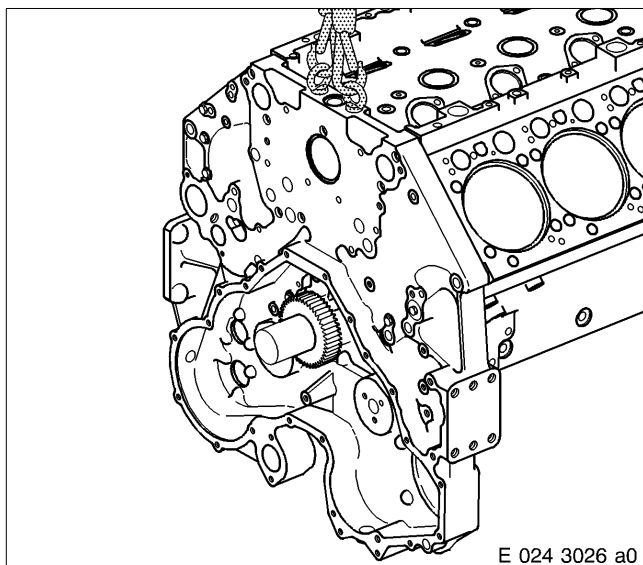

Removing gear case

⚠ WARNING

**Suspended load.
Risk of injury!
Only use lifting device provided by manufacturer and observe lifting instructions.
Never stand beneath a suspended load.**

Insert the lifting eyes into gear case.
Attach gear case to crane with ropes and tension ropes equally.
Mark all screws for gear case (varying lengths, designs) and remove.
Carefully push gear case, with the ropes pre-tensioned, in direction of free end until it is freed from crankcase.
Remove sealing rings and gasket.

C 024.05.08 Inspection and Repair

Clean all components.

Thoroughly clean oil bores and oil chambers in gear case and gear case cover and ensure the components are perfectly clean.

Using the magnetic crack-testing method with fluorescent magnetic powder, check gear case and gear case cover for cracks; if cracks are present, replace affected component.

Check crankshaft bearing for wear, scoring and marks; replace gear case cover if necessary.

Check condition of threads in gear case and gear case cover, rechase if necessary.

Check threads and shanks of hex screws for damage; replace screws as necessary.

Check all mating and sealing faces and fits. Rub down with oilstone or emery cloth as necessary.

Check dowel pin for damage, replace as required.

Replace elbow (Elastomer) during W6 Maintenance Echelon.

Replace plugs if necessary (e.g. in event of leakages).

Replace gaskets and O-rings at every assembly.

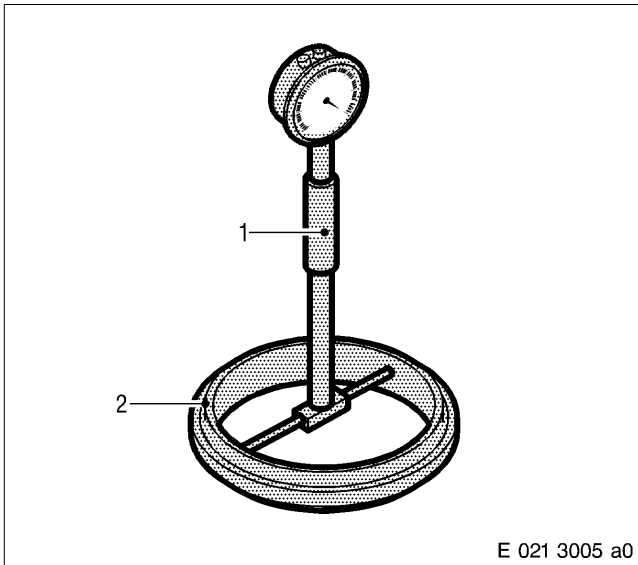

Measuring crankcase bearing bore in gear case cover

Adjust bore gauge (1) and dial gauge with micrometer or gauge ring (2) to basic size for crankshaft bearing bore as per Tolerances and Wear Limits List.

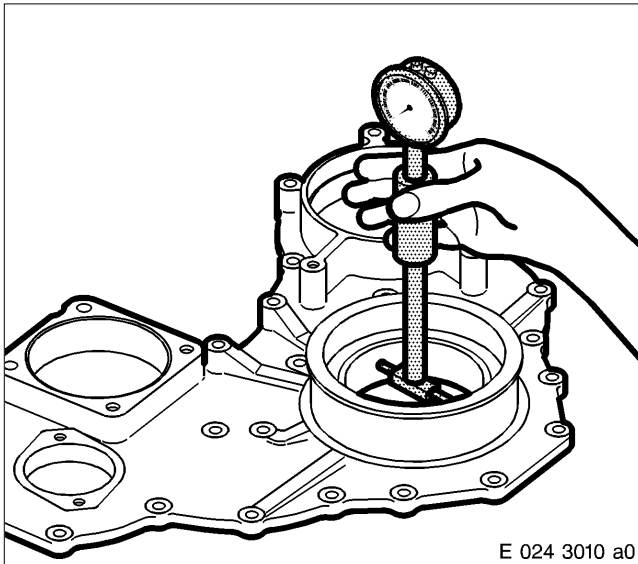

Measure diameter of crankshaft bearing bore with bore gauge.

Enter measurement values in data sheet.

For measuring points and limit values, see Tolerances and Wear Limits List.

If wear limits are exceeded, replace gear case cover.

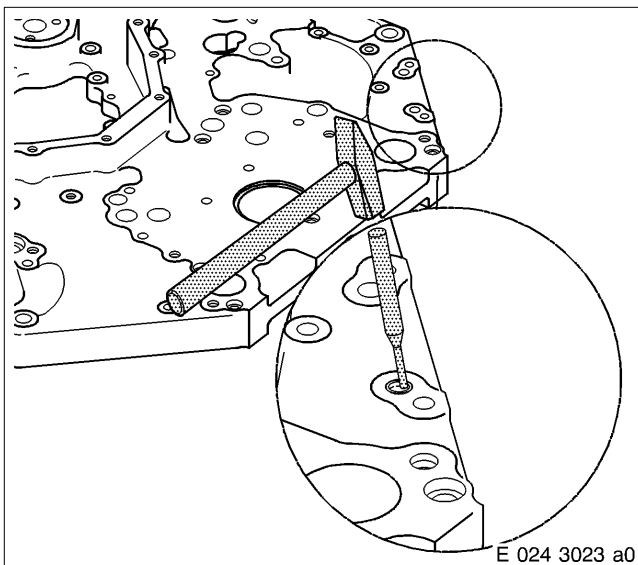

Replacing end cover in gear cases, free end

Note: Replace end cover only if necessary (e.g. in event of leakages).

Using a mandrel (1) and hammer, carefully tap cover into bore at one side until it tilts. Use pliers to remove cover from bore.

When removing, take great care that cover does not fall into bore and that sealing face of bore is not damaged.

Never attempt to drill a hole in cover, as chips of metal in engine cooling jacket can cause localized overheating.

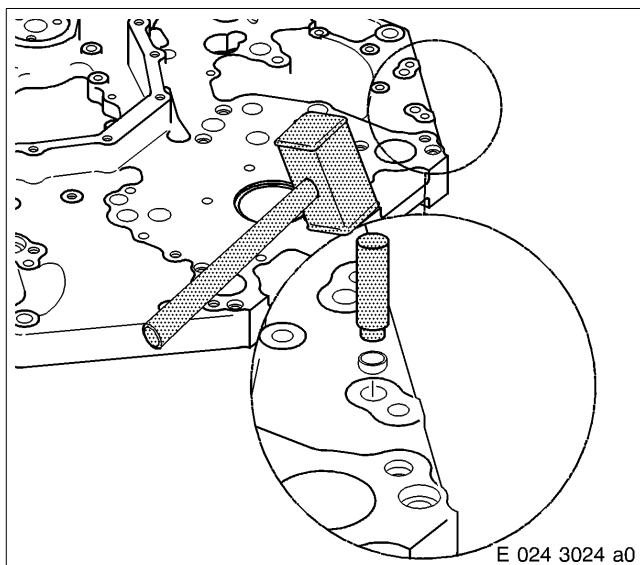

Clean and degrease seating faces of cover and bore gear case, free end.

Coat seating face of cover with thread locking compound.

Using a mandrel and hammer, drive cover into bore until flush.

Note: Ensure correct final strength of thread-locking agent, see C 020!

Replacing pipe in gear case, free end

Note: Only replace pipe when necessary (e.g. if damaged). Pipe is secured with thread-locking liquid.

Heat pipe to approx. 130 °C and withdraw from the gear case, driving end, see C 024.05.01.

Clean and degrease seating faces on pipe and bore in gear case.

Coat seating face of pipe with thread-locking agent.

Insert pipe into bore until it contacts the stop.

Note: Ensure correct final strength of thread-locking agent, see C 020!

C 024.05.11 Installation

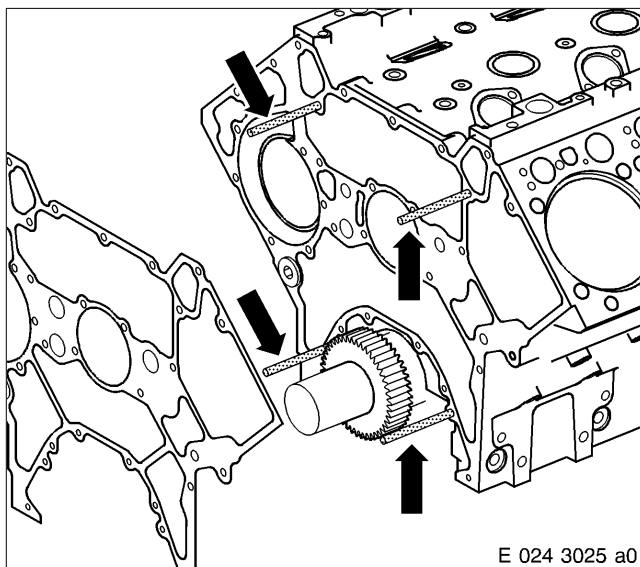

Installing gear case

Clean mating face on crankcase and gear case, free end.

For positioning the gaskets, apply a thin, dotted coat of sealing paste to the mating surfaces of the crankcase.

Insert suitable guide pins (arrows) into crankcase.

Place new gasket on top of the guide pins.

Adjust gasket lengthwise at the oil pan mating surface (cut off).

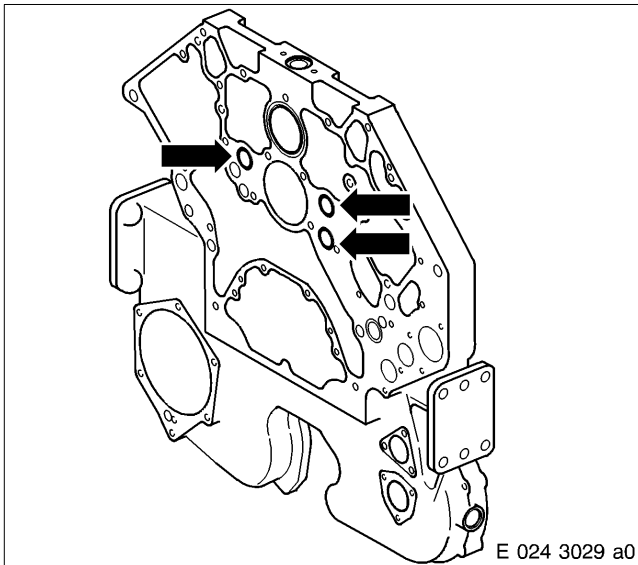

Coat sealing rings (arrows) with petroleum jelly and insert in grooves on gear case.

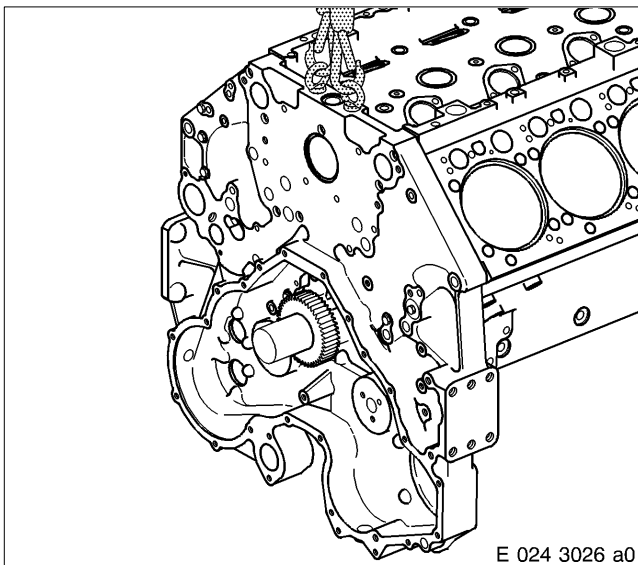

WARNING
<p>Suspended load. Risk of injury! Only use lifting device provided by manufacturer and observe lifting instructions. Never stand beneath a suspended load.</p>

Screw lifting eyes into gear case and secure to crane with rope.
Carefully move gear case with crane via guide pins and alignment tools on crankcase.
Remove lifting ropes and eyes.

Note: Take note of markings of the screws and note that screws differ in length.

Install all securing screws and tighten uniformly.
Cut projecting gasket so that it is flush with oil pan sealing surfaces.

Note: Ensure correct final strength of surface sealant, see C 020!

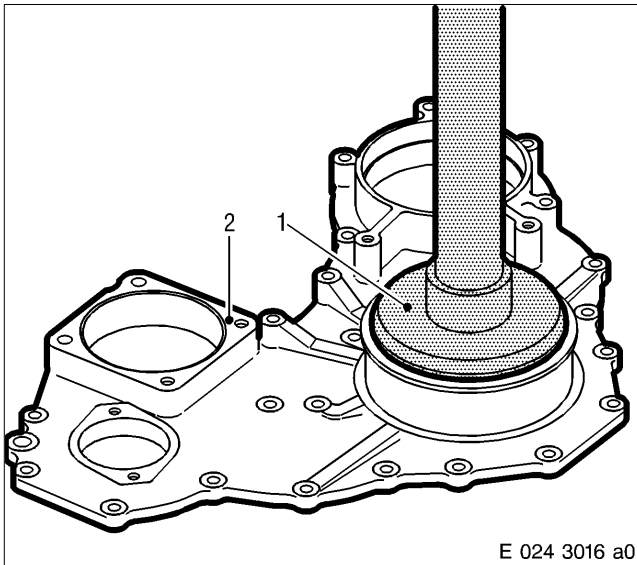

E 024 3016 a0

Completing and installing gear case cover

Fit radial-lip shaft seal, with sealing lip facing downwards, on press-in mandrel (1).

Coat sealing face of radial-lip oil seal with denaturated ethanol.

Note: Denaturated ethanol acts as lubricant for press-fitting.

Clean and degrease sealing face for radial-lip oil seal in gear case cover (2).

Press-fit radial-lip shaft seal with drift into flywheel housing.

Note: Radial-lip shaft seal clearance in gear case cover is 7 to 9 mm.

Install shock damper, see C231.05.

Install intermediate gears and axles – see C 025.05.01.

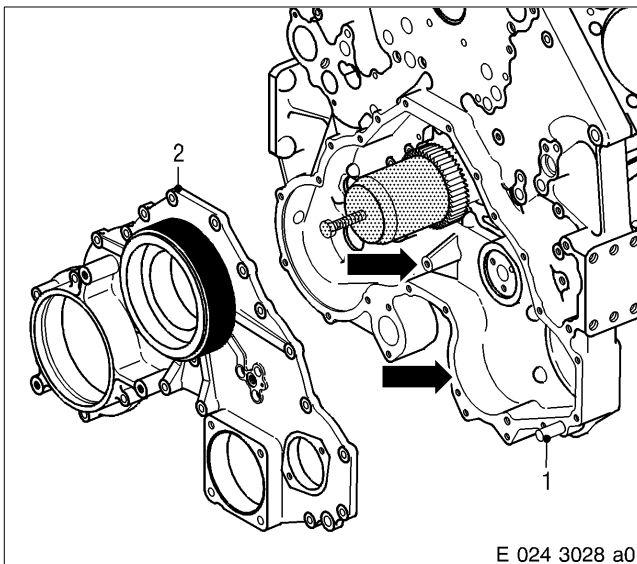

E 024 3028 a0

Back off jackscrew on alignment tool, mount the alignment tool on the crankshaft and press on by hand in direction driving end.

Clean and degrease mating faces (arrows) of gear case and coat with surface sealant.

Insert centering pin (1) into gear case (flat end of centering pin facing crankshaft centreline).

Clean and degrease mating face on gear case cover (2).

Carefully move gear case cover via alignment tools on gear case.

Screw in all securing screws as shown in General View – see C 024.05.01 and tighten uniformly.

Note: Make sure components are reinstalled in accordance with markings, and note that screws differ in length.

Press off alignment tool from crankshaft using jackscrew.



C 024.05.12 After-Installation Operations

A distinction must be made as to whether:

- 1 ————— The engine is to be completely disassembled
- 2 ————— The engine is to be removed but not disassembled
- 3 ————— The engine is to remain installed

1	2	3	Operations	See
x	—	—	Perform operations as per Assembly Plan	B 005
x	—	—	Install engine	B 007
—	x	x	Install oil pan	C 014.05
—	x	x	Install engine mounting, free end	C 231.05
—	x	x	Install coolant control housing	C 206.05
—	x	x	Install fan drive	C 221.05
—	x	x	Install generator	C 213.05
—	x	x	Press-fit flange, free end	C 035.05
—	x	x	Install vibration damper	C 035
—	x	x	Install engine coolant pump	C 202.05
—	x	x	Install charge air coolant pump	—
—	x	x	Install air compressor	C 362.40
—	x	x	Install fuel delivery pump	C 081.05
—	x	x	Connect coolant lines	C 202.15
—	x	x	Install fuel lines	C 082.05/C 084.05
—	x	x	Install fuel duplex filter	C 083.05
—	x	x	Install oil lines	C 181.20
—	x	x	Install V-belt	C 028.05
—	x	x	Connect electric cables	—
—	—	x	Fill oil system with engine oil	Operating Instructions
—	—	x	Fill engine coolant system	Operating Instructions
—	—	x	Check engine alignment; realign engine if necessary	Special Publication
—	—	x	Release engine start	Operating Instructions

C 025.05 Gear Train, Free End

C 025.05.01 General View

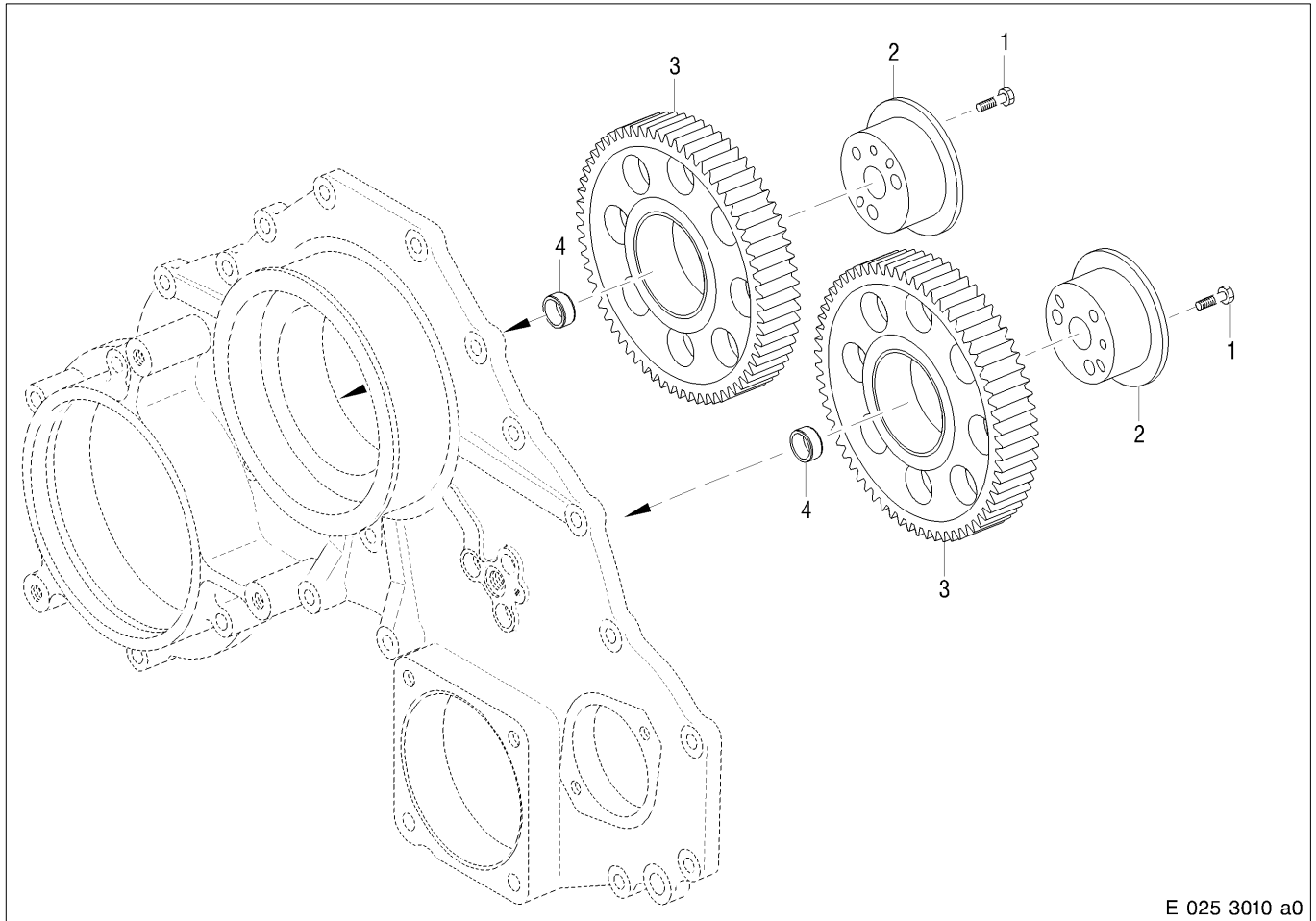

- 1 Hex screw
- 2 Axle
- 3 Idler gear
- 4 Sleeve

C 025.05.02 Special Tool

Designation – Application	Number
Press-in mandrel for sleeve	1

C 025.05.04 Before-Removal Operations

x	-	-	Remove engine	B 003
x	-	-	Perform operations as per Disassembly Plan	B 004
-	-	x	Disable engine start	Operating Instructions
-	-	x	Drain engine coolant	Operating Instructions
-	-	x	Drain charge air coolant	-
-	-	x	Drain or draw off engine oil	Operating Instructions
-	x	x	Disconnect fuel lines	C 082.05/C 084.05
-	x	x	Disconnect electric wiring	-
-	x	x	Remove fuel delivery pump	C 081.05
-	x	x	Remove V-belt	C 028.05
-	x	x	Remove coolant lines	C 202.15
-	x	x	Remove engine coolant pump	C 202.05
-	x	x	Remove charge air coolant pump	-
-	x	x	Remove vibration damper	C 035.05
-	x	x	Remove flange, free end	C 035.05
-	x	x	Remove oil lines	C 181.20
-	x	x	Remove generator	C 213.05
-	x	x	Removing gear case cover	C 024.05

* – not always applicable (order-specific) –

C 025.05.05 Removal

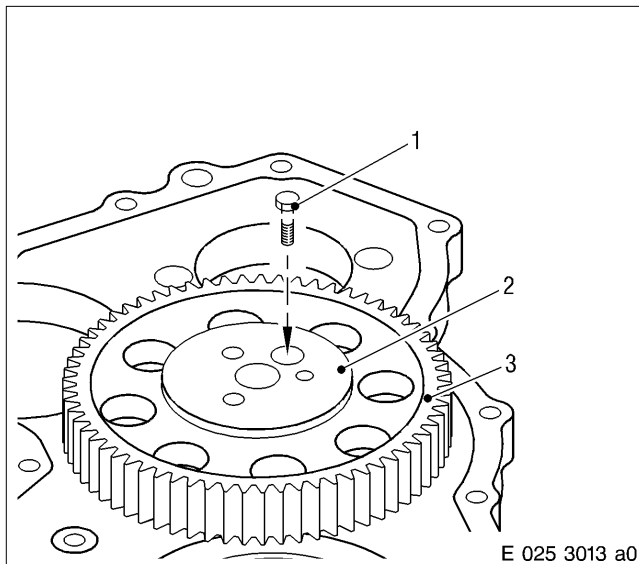

Remove intermediate gears and axles

Mark idler gears and axles according to installation point.

Remove hex bolt (1) and pull axle (2) with idler gear (3) from the sleeve.

Remove sleeve from gear case cover.

C 025.05.08 Inspection and Repair

Clean all components.

Using magnetic crack-testing method and fluorescent magnetic powder, check idler gears for cracks; if cracks are detected, replace idler gear.

Check surface condition of idler gear with magnifying glass; replace idler gear if necessary.

Check running surface of axles, bearing bushes in idler gears and axial friction faces of gears for wear and scores.

Remove minor scoring and wear by rubbing down with emery cloth or oilstone; replace component if necessary.

Check condition of sleeves; replace if necessary.

Check screws for damage and check condition of threads; replace screws if necessary.

Thoroughly clean all axle oilways; make sure oilways are perfectly clean.

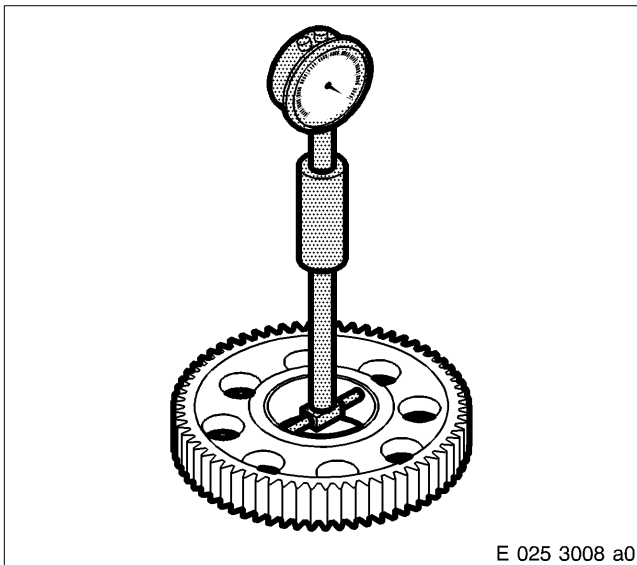

Measuring bearing bush bore in idler gear

Set bore gauge to basic size of bearing bush bore in idler gear.

Measure diameter of bore.

For limit values, see Tolerances and Wear Limits List.

If limit values are exceeded, replace idler gear.

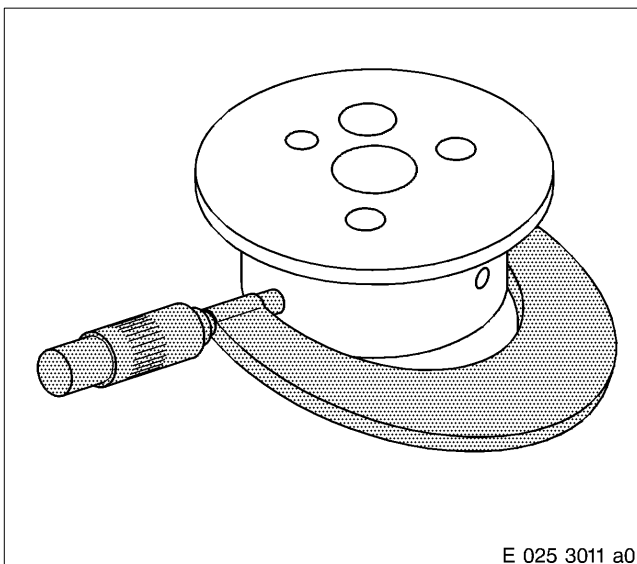

Measuring bearing diameter on axles

Using micrometer, measure outside diameter of axles at running surface.

For limit values, see Tolerances and Wear Limits List.

Replace axle if limit values are exceeded.

C 025.05.11 Installation

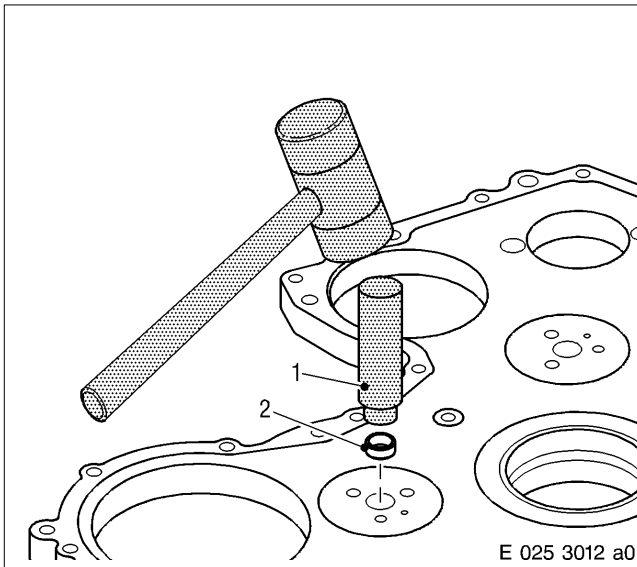

Installing intermediate gears and axles

Note: Make sure all components are perfectly clean.

Using a press-in mandrel (1) install sleeve (2) firmly in the appropriate bore in gear case cover.

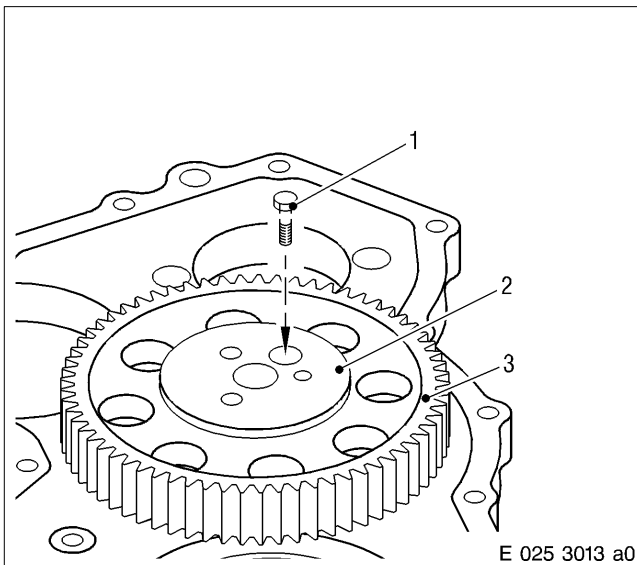

Coat axles and bearing bushes in idler gears with engine oil.

Mount idler gear (3) according to markings on the axles (2) and mount the axles according to their markings (location) over the sleeves.

Fit hex bolt (1) to the guide.

Note: Ensure axle oil bores are unobstructed!

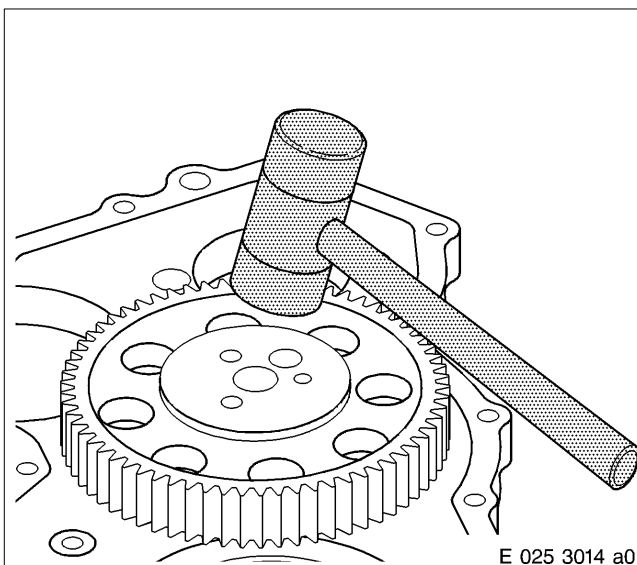

Use plastic mallet to drive axles via the sleeves to the stop.

Tighten hex bolt in the axle.

Check ease of movement by turning the idler gears; the idler gears must turn easily.

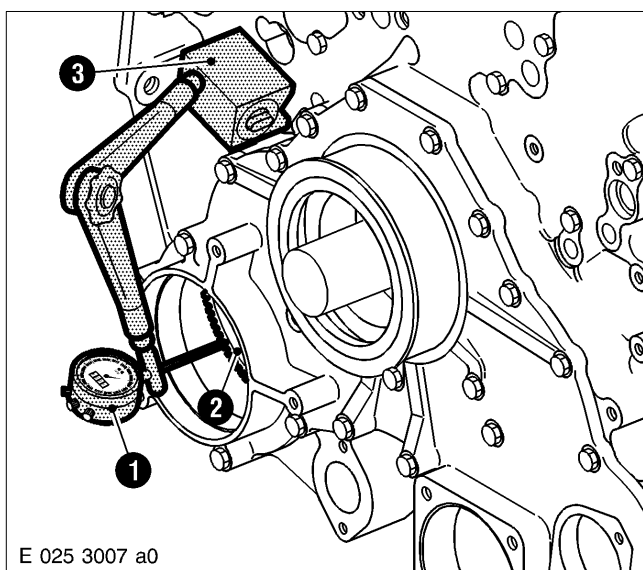

Checking axial clearance and backlash

Install gear case cover, see C 024.05.

Align magnetic-base indicator holder (3) with dial gauge (1) with gear case cover.

Place dial gauge stylus with preload on lateral collar of idler gear (2).

Set dial gauge to zero.

Check axial play by moving idler gear back and forth in axial direction.

To measure backlash, place switch of Puppi gauge with preload on tooth flank of idler gear.

Move idler gear back and forth in radial direction to check backlash.

For axial clearance and backlash, See C 020.

C 025.05.12 After-Installation Operations

A distinction must be made as to whether:

- 1 ————— The engine is to be completely disassembled
- 2 ————— The engine is to be removed but not disassembled
- 3 ————— The engine is to remain installed

1	2	3	Operations	See
x	—	—	Perform operations as per Assembly Plan	B 005
x	—	—	Install engine	B 007
—	x	x	Press-fit flange, free end	C 035.05
—	x	x	Install vibration damper	C 035
—	x	x	Install engine coolant pump	C 202.05
—	x	x	Install charge air coolant pump	—
—	x	x	Install fuel delivery pump	C 081.05
—	x	x	Install generator	C 213.05
—	x	x	Connect coolant lines	C 202.15
—	x	x	Install fuel lines	C 082.05/C 084.05
—	x	x	Install oil lines	C 181.20
—	x	x	Install and adjust V-belt	C 028.05
—	x	x	Connect electric cables	—
—	—	x	Fill oil system with engine oil	Operating Instructions
—	—	x	Fill engine coolant system	Operating Instructions
—	—	x	Fill charge air coolant system	—
—	—	x	Release engine start	Operating Instructions



C 028.05 Belt Drive

C 028.05.01 General View

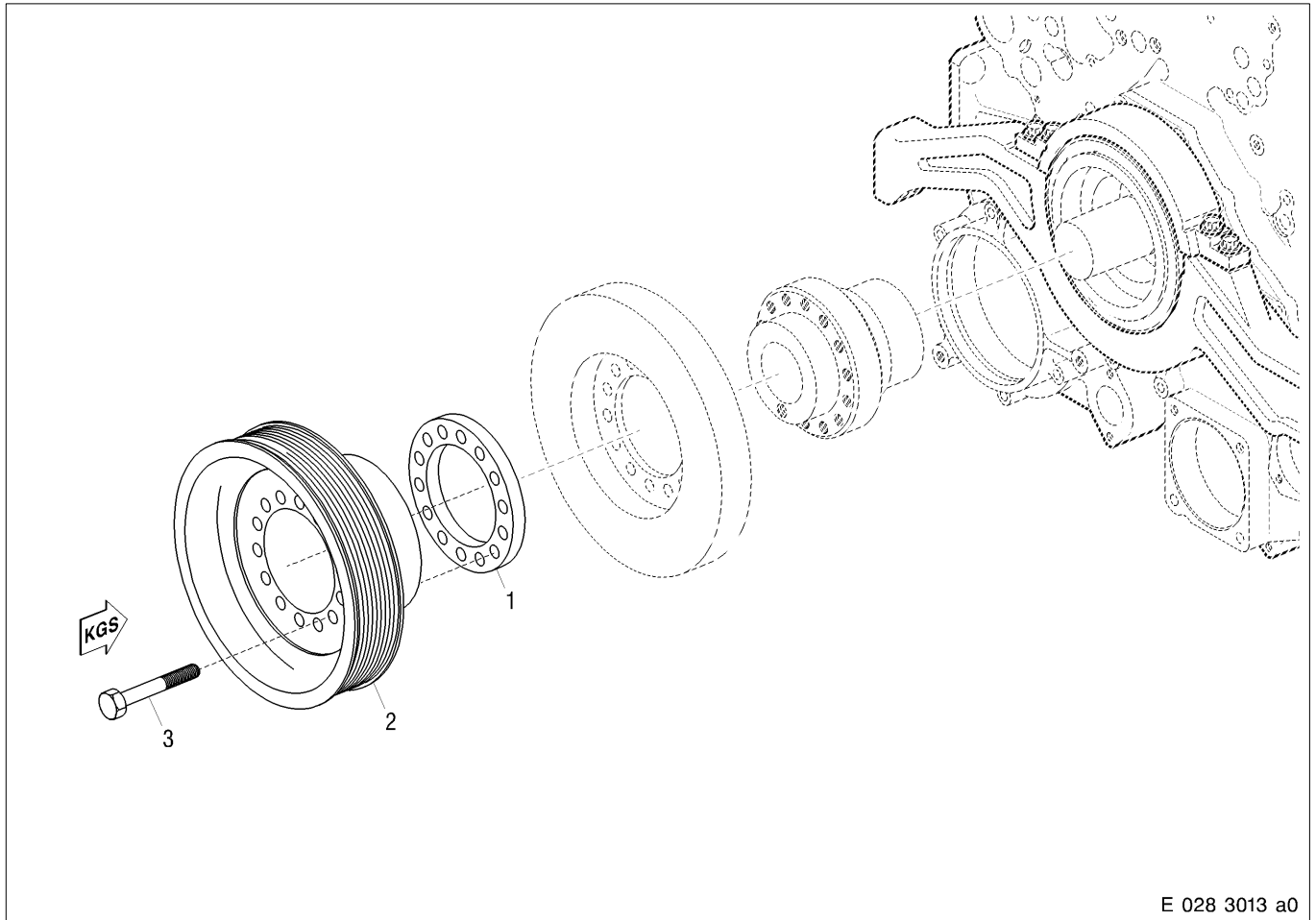

- 1 Spacer ring
 - 2 Belt pulley
 - 3 Hex screw
- Tightening torque: 180 Nm
Lubricant: Engine oil

Fan drive

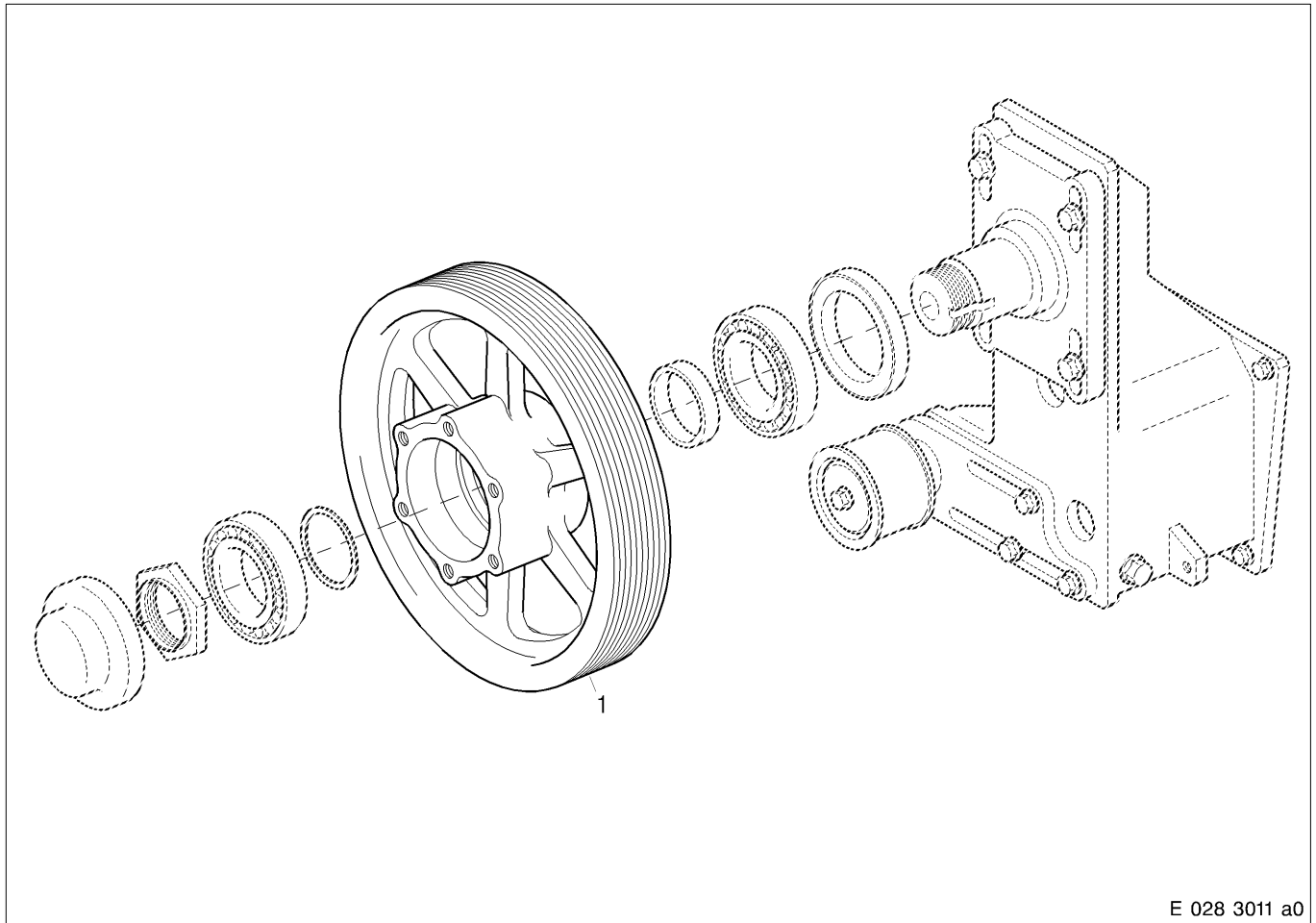

E 028 3011 a0

1 Belt pulley

Fan drive

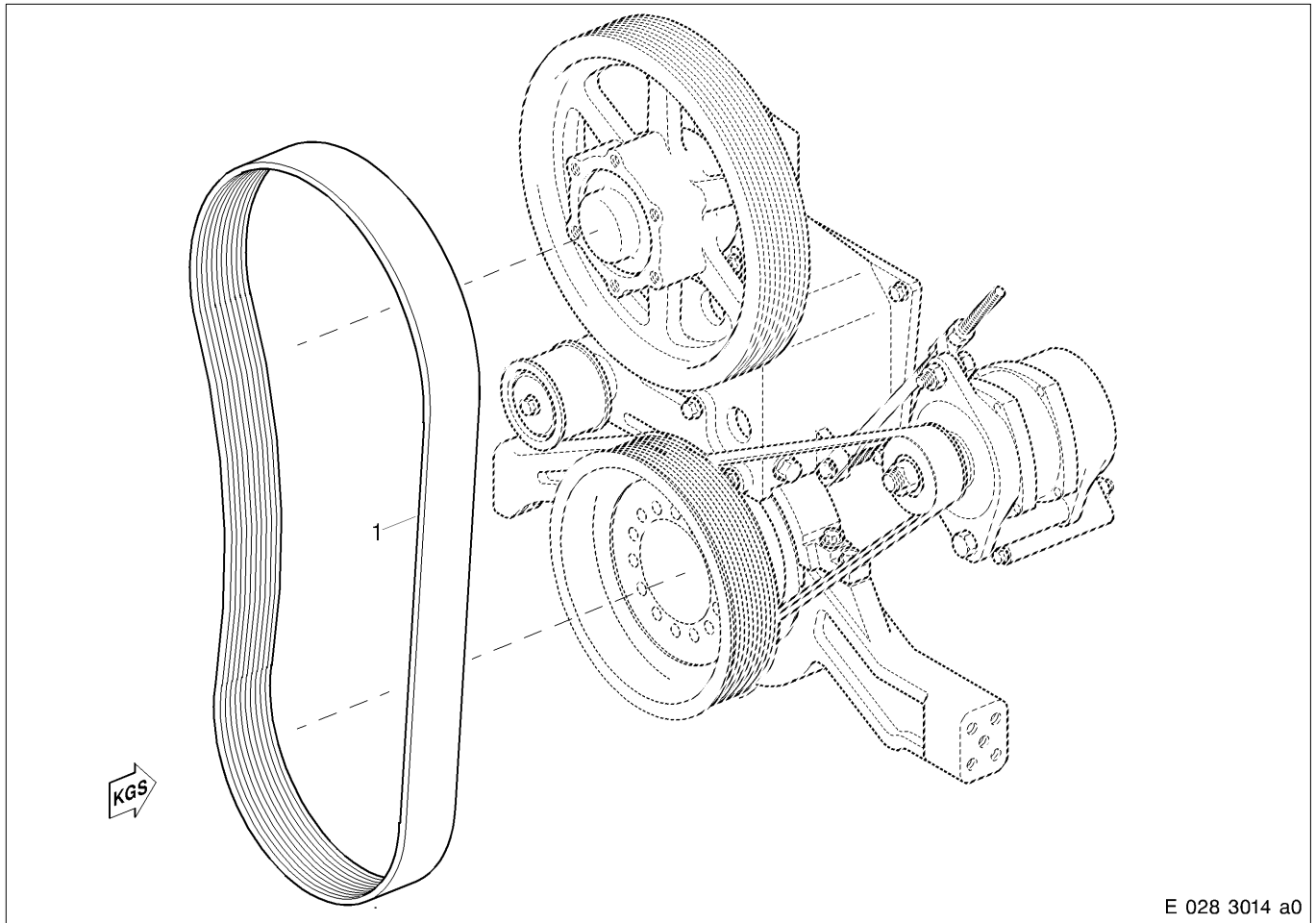

E 028 3014 a0

1 V-ribbed belt

Generator drive

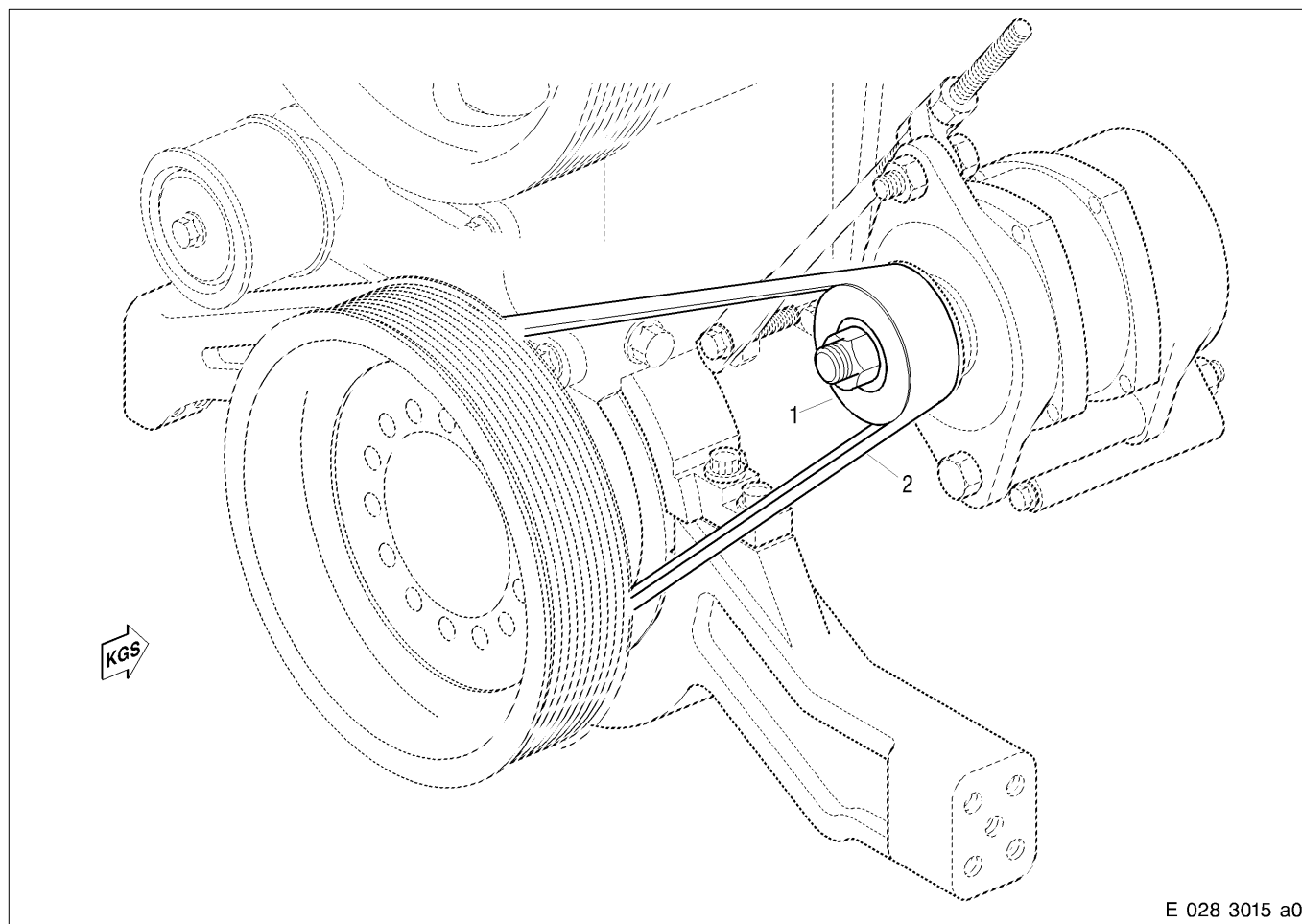

E 028 3015 a0

- 1 Belt pulley
- 2 V-ribbed belt

C 028.05.02 Special Tool

Designation – Application	Number
V-belt tension gauge	1

C 028.05.04 Before-Removal Operations

A distinction must be made as to whether:

- 1 ————— The engine is to be completely disassembled
- 2 ————— The engine is to be removed but not disassembled
- 3 ————— The engine is to remain installed

1	2	3	Operations	See
x	-	-	Remove engine	B 003
x	-	-	Perform operations as per Disassembly Plan	B 004
-	-	x	Disable engine start	Operating Instructions
-	x	x	Remove guard	-
-	x	x	Remove fan wheel	-

C 028.05.05 Removal

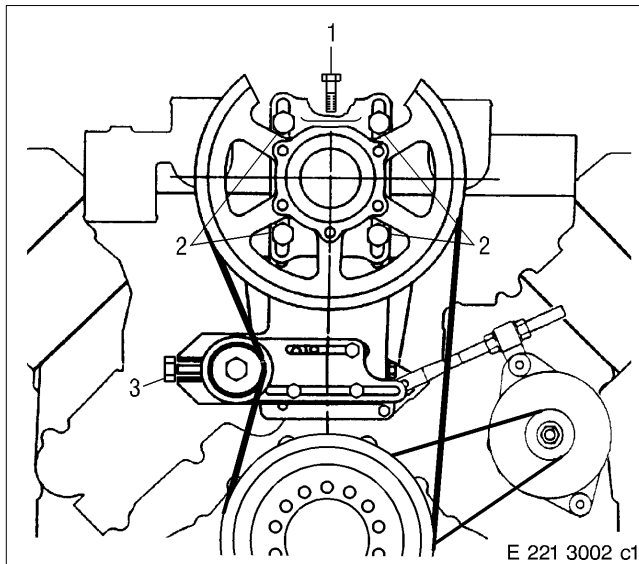

Removing V-ribbed belt and belt pulley for fan drive

Release belt tensioner securing screws and relieve the V-ribbed belt via the tightening screw (3).
Release fan coupling securing screws (2).
Turn the tightening screw (1) far enough to allow removal of V-ribbed belt.
Remove belt pulley as shown in General View – see C 028.05.01

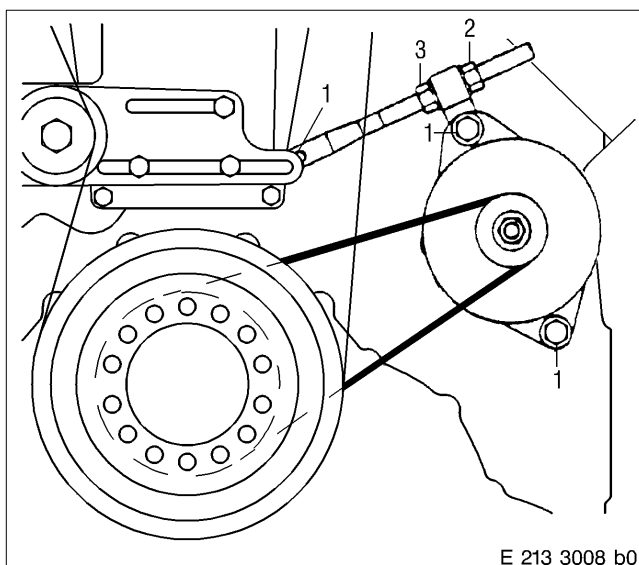

Remove V-ribbed belt for generator

Release securing screws (1).
Slacken locknut (2) and clamping nut (3) until the V-ribbed belts can be removed.

C 028.05.08 Inspection and Repair

Clean all components.

Check V-ribbed belt for cracks, fouling by oil, overheating and wear; clean or replace V-ribbed belt if necessary.

Note: Solvents such as benzene and benzol and sharp-edged objects must not be used.

Replace V-ribbed belt during W6 overhaul.

Check V-belt pulleys for wear, warping and damage; replace belt pulley if necessary.

Check mating face of belt pulley for evenness, smooth with an emery cloth or oilstone if necessary.

Check screws for damage and check condition of threads; replace screws if necessary.

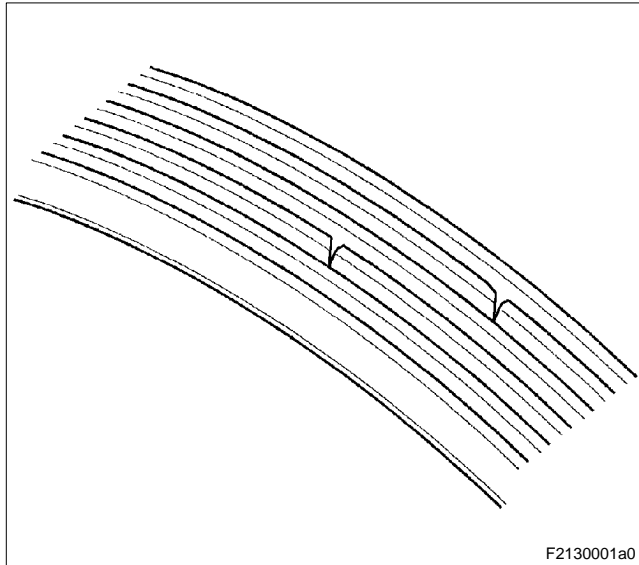

Damage characteristics of V-ribbed belt:

Normal wear.

One or two rib fractures of about 25 mm after long use can be regarded as normal; the V-ribbed belt can still be used.

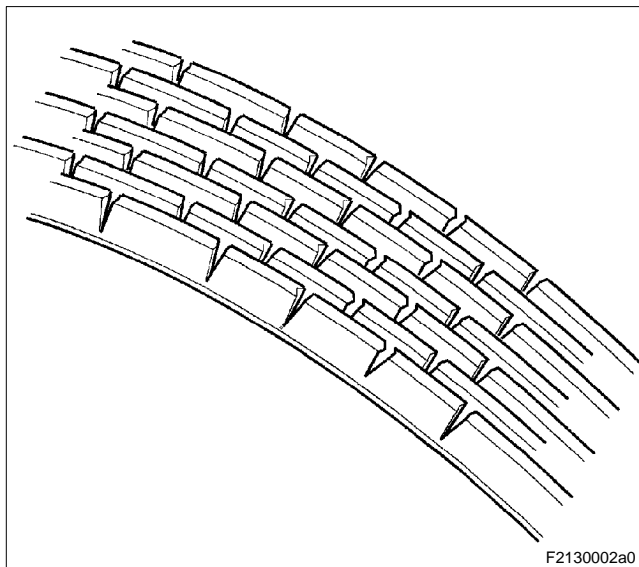

The V-ribbed belt must be replaced since the ribs are broken round the entire circumference.

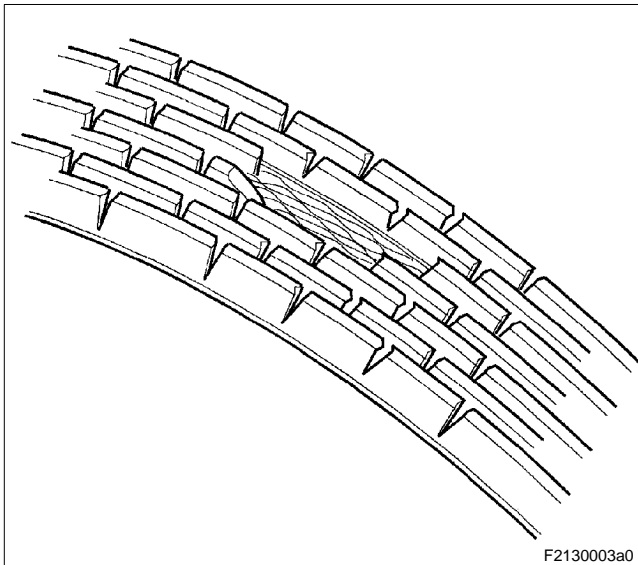

The V-ribbed belt must be replaced immediately since the rib material is broken and the ribs are broken round the entire circumference.

C 028.05.11 Installation

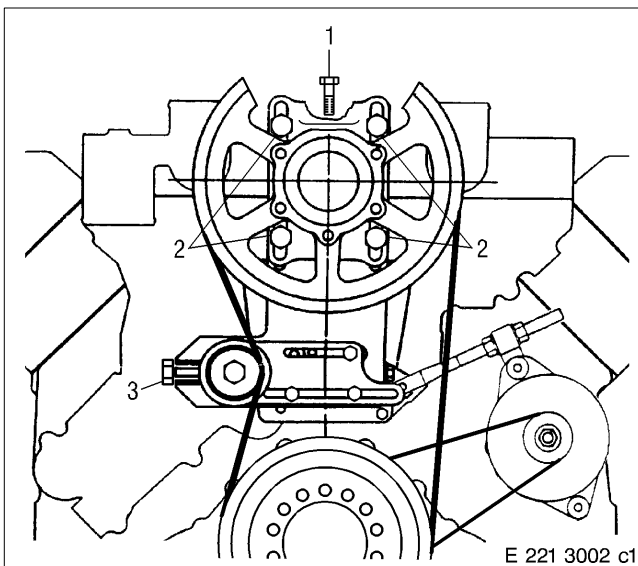

Installing belt pulley and V-ribbed belt for fan drive, adjusting V-belt tension

Check mating surfaces on belt pulley and fan coupling; clean if necessary.

Install belt pulley as shown in General View and tighten hex bolts in diagonally opposite sequence to specified tightening torque – see C 028.05.01.

Check V-belt pulley on fan coupling and crankshaft for contamination; clean if necessary.

Place new V-ribbed belt in position.

Pretension V-ribbed belt with tightening bolt (1).

Tighten air coupling securing screws (2) to specified tightening torque – see C 221.05.01

Tighten the V-ribbed belt with tightening bolt (3).

Note: Turn the tightening bolt to the right to increase V-ribbed belt tension.

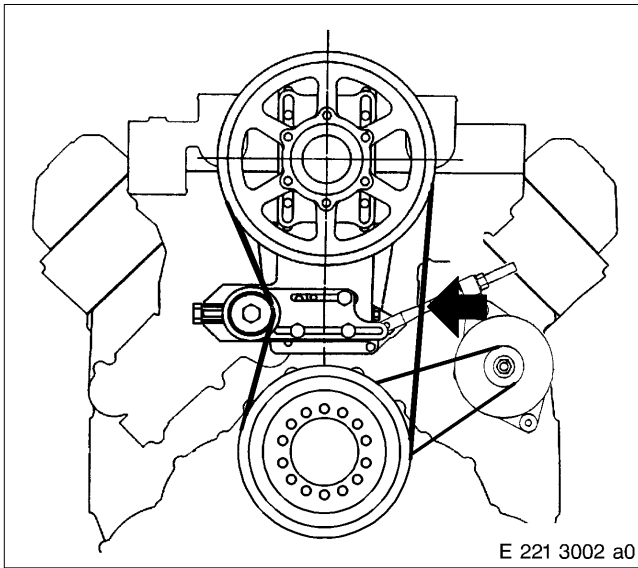

Place V-belt tension gauge on V-belt in centre (arrow) between belt pulleys.

Settings

New V-ribbed belt: from 168 kg to 190 kg
Run-in V-ribbed belt: 109 kg

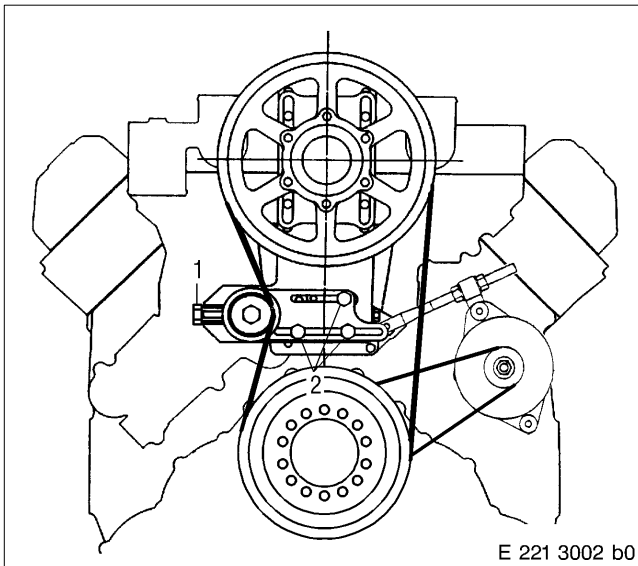

If measured value does not correspond to prescribed set value, correct V-belt tension with tightening bolt (1) and then tighten the securing screws (2).

Note: After approx. 30 minutes of engine operation, check V-belt tension once again, retension as necessary. After approx. 8 hours of engine operation, check V-belt tension once again, retension as necessary.

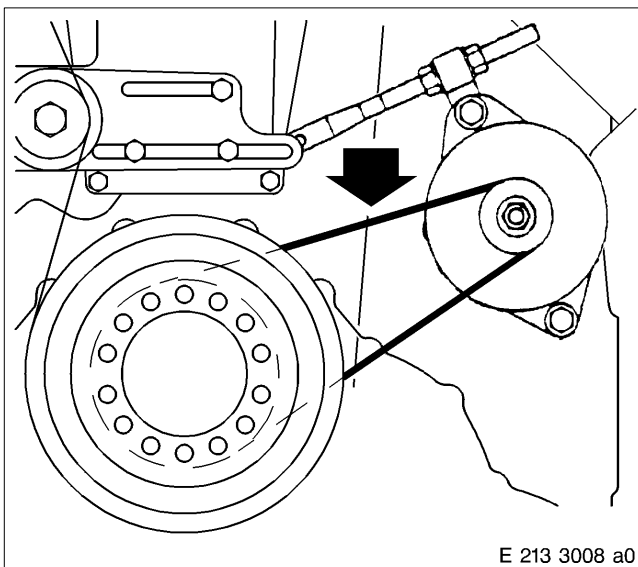

Installing belt pulley for generator and adjusting V-belt tension

Check V-belt pulley for contamination; clean if necessary.

Place new V-ribbed belt in position.

Tension V-ribbed belt with clamping nut.

Place V-belt tension gauge on V-ribbed belt in centre (arrow) between belt pulleys.

Settings

New V-ribbed belt: from 64 kg to 75 kg
Run-in V-ribbed belt: 61 kg

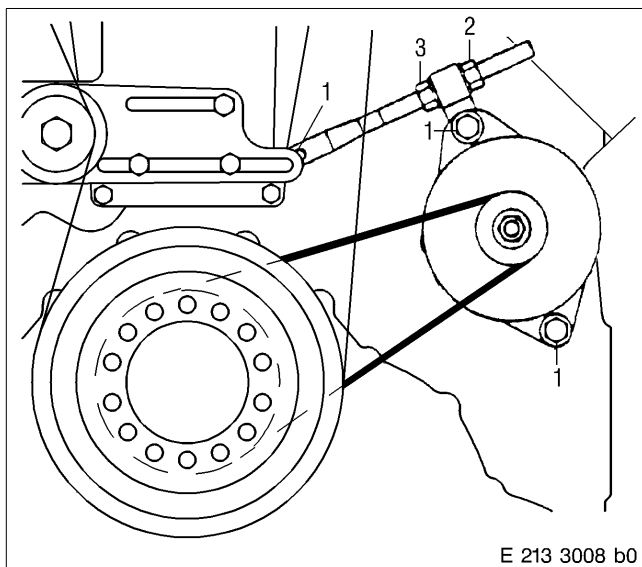

If measured value does not correspond to prescribed set value, correct V-belt tension with clamping nut (3) and then tighten locknut (2).

Tighten securing screws (1) to specified tightening torque – see C 213.05.01.

Note: After approx. 30 minutes of engine operation, check V-belt tension once again, retension as necessary. After approx. 8 hours of engine operation, check V-belt tension once again, retension as necessary.

E 213 3008 b0

C 028.05.12 After-Installation Operations

A distinction must be made as to whether:

- 1 ————— The engine is to be completely disassembled
- 2 ————— The engine is to be removed but not disassembled
- 3 ————— The engine is to remain installed

1	2	3	Operations	See
x	–	–	Perform operations as per Assembly Plan	B 005
x	–	–	Install engine	B 007
–	x	x	Install fan wheel	–
–	x	x	Install guard	–
–	–	x	Release engine start	Operating Instructions



Contents

C 030	Running Gear
C 031.05	Crankshaft
C 031.05.01	General view
C 031.05.02	Special tool
C 031.05.04	Before-removal operations
C 031.05.05	Removal
C 031.05.06	Assembly
C 031.05.08	Inspection and repair
C 031.05.10	Disassembly
C 031.05.11	Installation
C 031.05.12	After-installation operations
C 032.05	Main PTO, driving end
C 032.05.01	General view
C 032.05.02	Special tool
C 032.05.04	Before-removal operations
C 032.05.05	Removal
C 032.05.06	Assembly
C 032.05.08	Inspection and repair
C 032.05.10	Disassembly
C 032.05.11	Installation
C 032.05.12	After-installation operations
C 035.05	PTO, free end
C 035.05.01	General view
C 035.05.02	Special tool
C 035.05.04	Before-removal operations
C 035.05.05	Removal
C 035.05.08	Inspection and repair
C 035.05.11	Installation
C 035.05.12	After-installation operations
C 037.05	Pistons and conrods
C 037.05.01	General view
C 037.05.02	Special tool
C 037.05.04	Before-removal operations
C 037.05.05	Removal
C 037.05.06	Assembly
C 037.05.08	Inspection and repair
C 037.05.10	Disassembly
C 037.05.11	Installation
C 037.05.12	After-installation operations

C 030 Running Gear

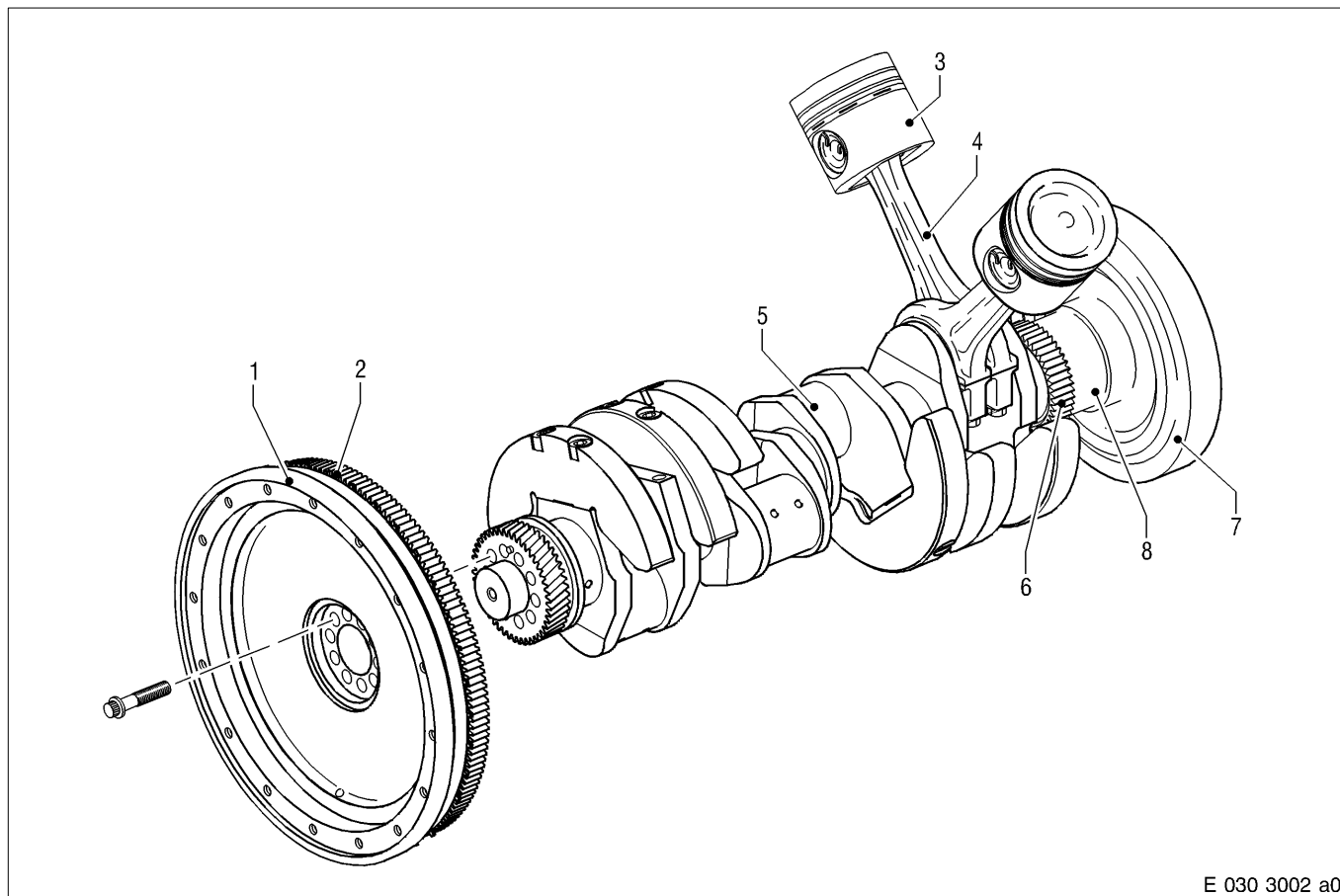

E 030 3002 a0

- 1 Flywheel
- 2 Ring gear
- 3 Piston
- 4 Conrod

- 5 Crankshaft
- 6 Crankshaft gear, free end
- 7 Vibration damper
- 8 Hub

The following is a list of auxiliary equipment and materials needed for the assembly operations:

!	CAUTION
<p>When using these miscellaneous materials, it is essential to observe the manufacturer's instructions for use, safety instructions and waste disposal specifications.</p>	

Auxiliary Equipment and Materials	Designation	Order No.		Remarks
		MTU	DDC	
Chamois leather				
Bristle brush				
Roller brush				
Brass brush				
Polishing cloth				
Magnifier				
Spray gun				
Inspection lamp				
Endoscope with cold light				
Liquid nitrogen				
Vaseline	Petroleum jelly, white	40317		
Denaturated ethanol		40250		
Thin-film lubricant	Molycote g-N plus	40041		
Engine oil				
Corrosion preventive	Caramba Express	40008		
Cleaning agent	Solvclean KW	40022		
Engineer's blue	blue	40641		
Kerosene or diesel fuel				
Cleaner (decarbonizer)	Meister Proper	40377		
Dry compressed air				
Magnetic crack-testing equipment with fluorescent magnetic powder				
Surface crack-testing equipment with red penetrant dye				
Surface crack-testing equipment with fluorescent penetrant dye				



C 031.05 Crankshaft

C 031.05.01 General View

Crankshaft in crankcase

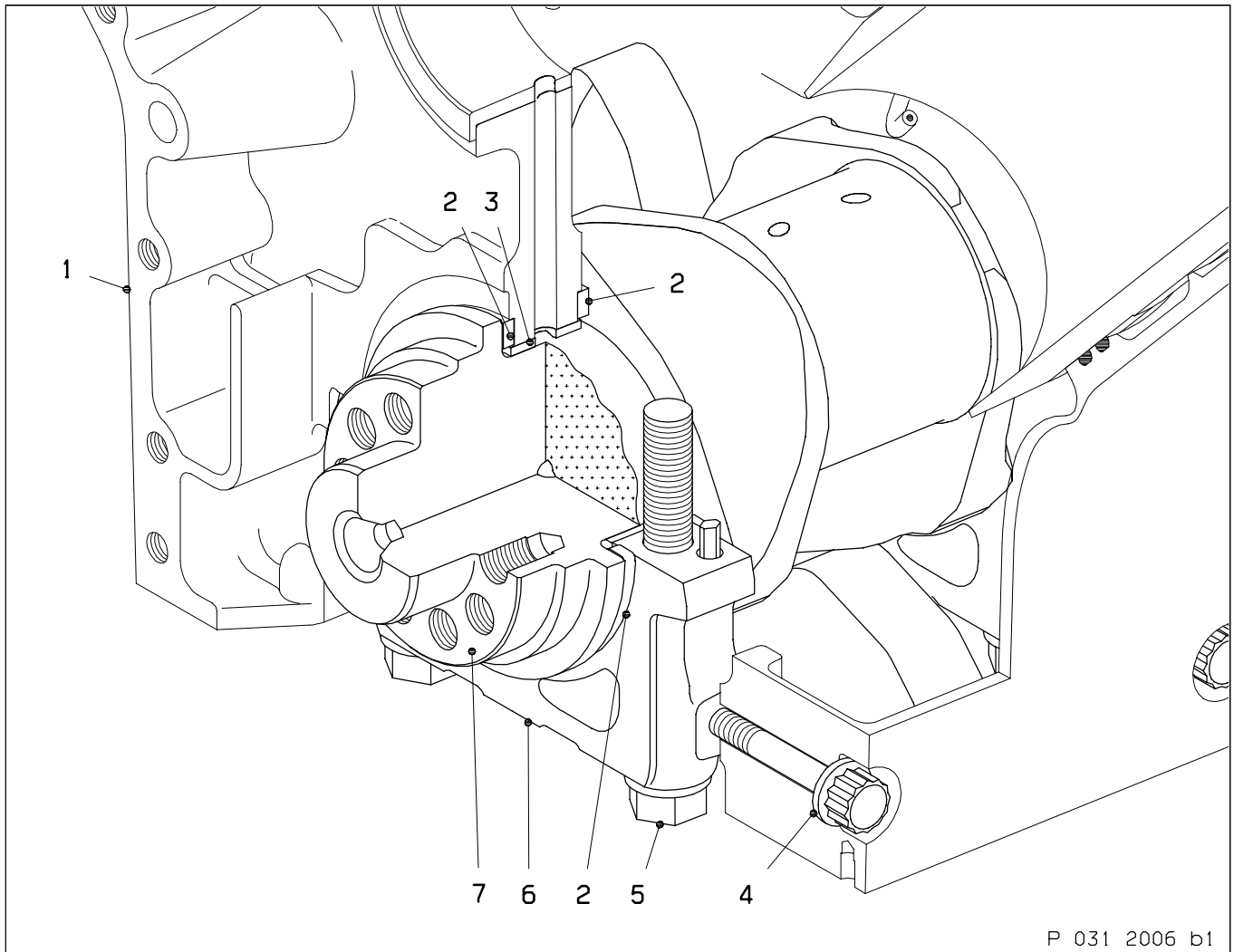

P 031 2006 b1

- 1 Crankcase
- 2 Friction washer
- 3 Crankshaft bearing
- 4 Double-hex screw *
Tightening torque: 120 Nm + 10 Nm
Lubricant: Engine oil
- 5 Hex screw
Max. shaft length: 176 mm
Pretightening torque: 300 Nm + 30 Nm
Angle of further rotation: $90^\circ \pm 10^\circ$
Lubricant: Engine oil
- 6 Bearing cap
- 7 Crankshaft

* Tightening sequence: Hex bolts before double-hex screws

Axial mounting of crankshaft

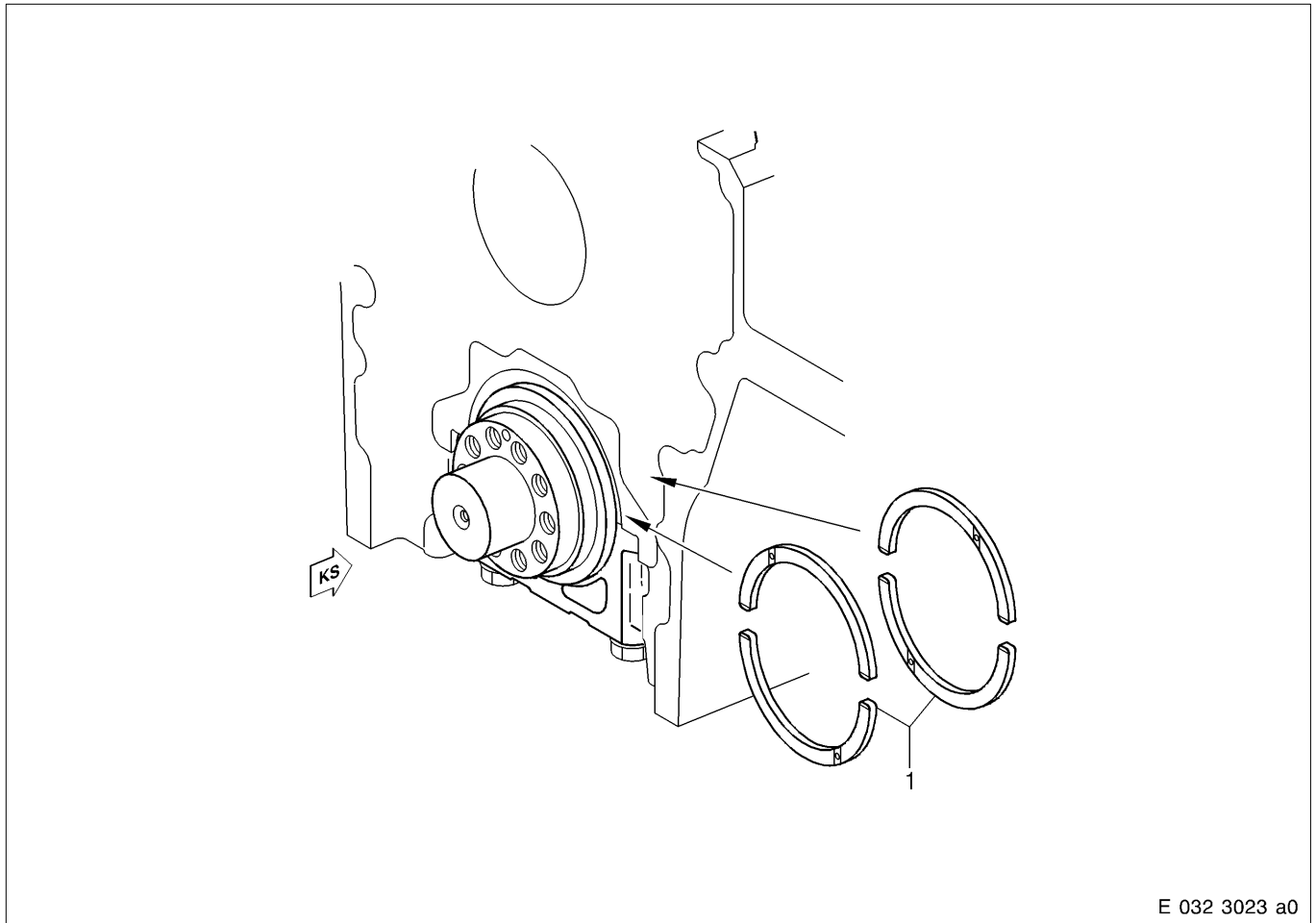

E 032 3023 a0

1 Friction washer

Crankshaft

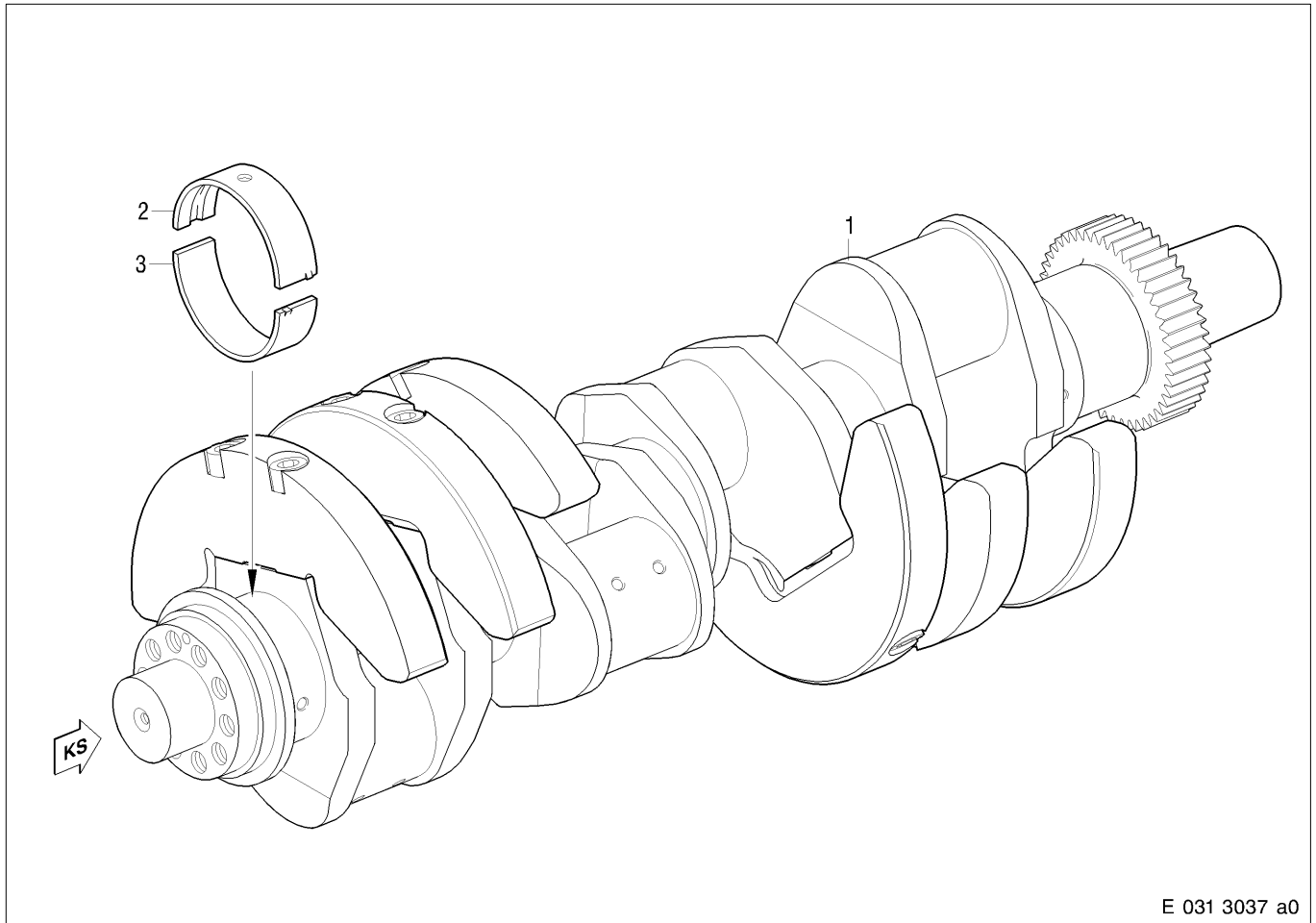

- 1 Crankshaft
- 2 Main bearing, top
- 3 Main bearing, bottom

Crankshaft

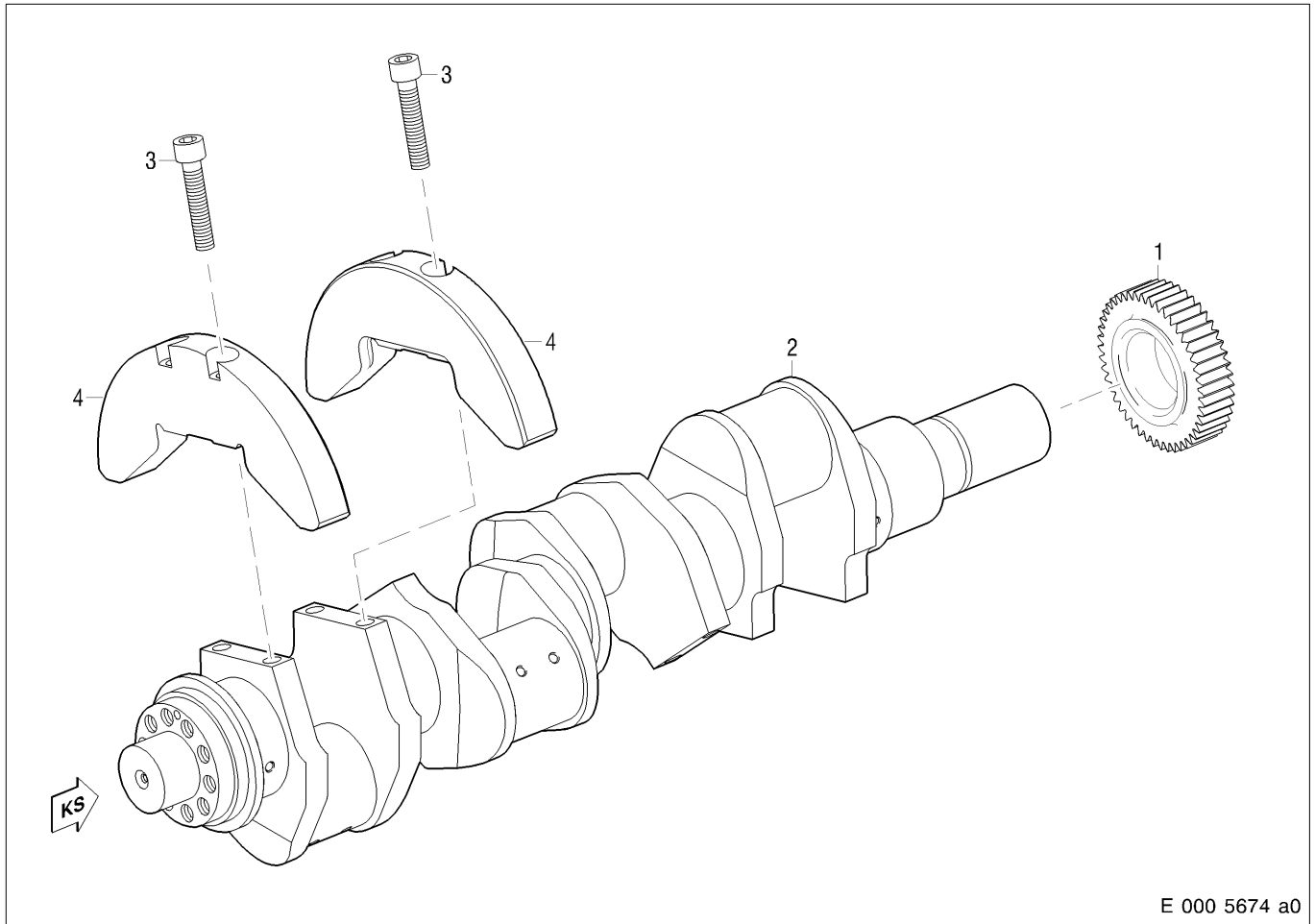

- 1 Crankshaft gear, free end
- 2 Crankshaft
- 3 Screw
 - Max. shaft length: 84 mm
 - Pretightening torque: 140 Nm + 20 Nm
 - Angle of further rotation: 90° + 10°
 - Lubricant: Engine oil
- 4 Counterweight

C 031.05.02 Special Tool

Designation – Application	Number
Assembly bolts for crankshaft in crankcase	4

C 031.05.04 Before-Removal Operations

A distinction must be made as to whether:

- 1 ————— The engine is to be completely disassembled
- 2 ————— The engine is to be removed but not disassembled
- 3 ————— The engine is to remain installed

1	2	3	Operations	See
x	-	-	Remove engine	B 003
x	-	-	Perform operations as per Disassembly Plan	B 004
-	x	x	Removal of crankshaft not scheduled	-

C 031.05.05 Removal

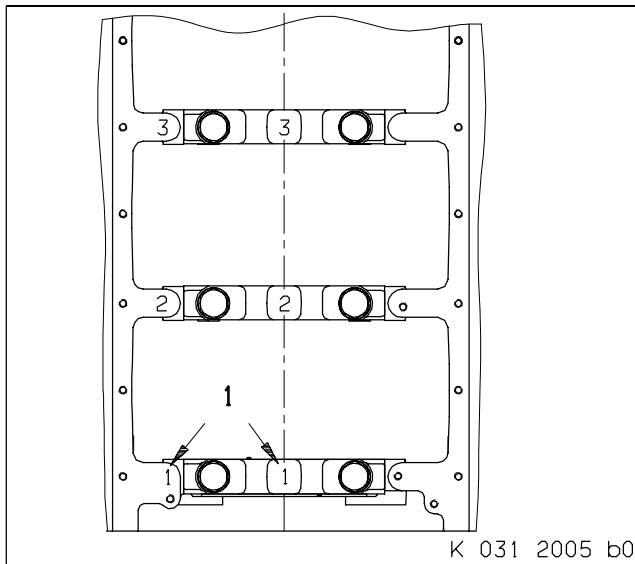

Checking marking on crankshaft bearing cap

Check marking on crankshaft bearing cap to crankshaft, and if necessary mark according to sequence.

- 1 – Starting at driving end, stamp number of main bearing with 6 mm numbers so that they can be read from same direction.

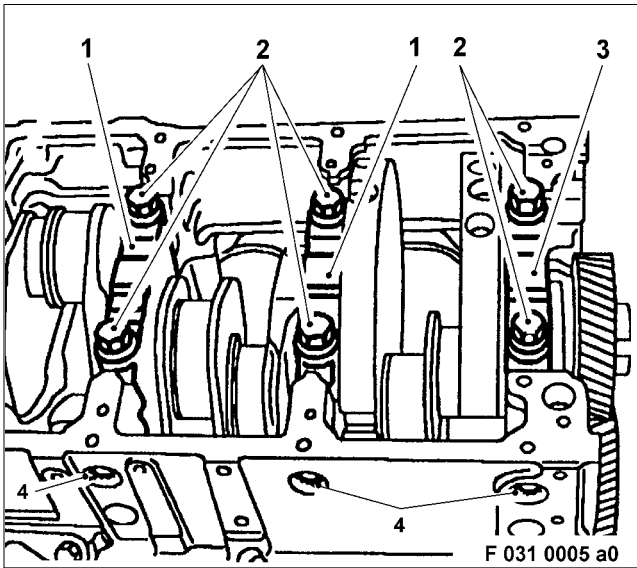

Removing main bearing caps

Crankcase is upside down, with oil pan mating face horizontal.

Using a ratchet and socket, remove all side double-hex screws (4) for alignment bearing cover (3) and crankshaft bearing cap (1).

Remove hex screws for crankshaft bearing cap with ratchet and socket.

Note: Release screws on one bearing at same time.

CAUTION

**Components have sharp edges.
Risk of injury.
Touch components only when wearing protective gloves.**

Carefully raise all bearing caps vertically until clear of crankcase.

Mark bearing shell of respective bearing cap and remove.

Note: Protect bearing shells from damage!

Remove friction washers from crankshaft alignment bearing cap.

Removing crankshaft

To protect crankshaft, insert four assembly bolts on first and last bearing.

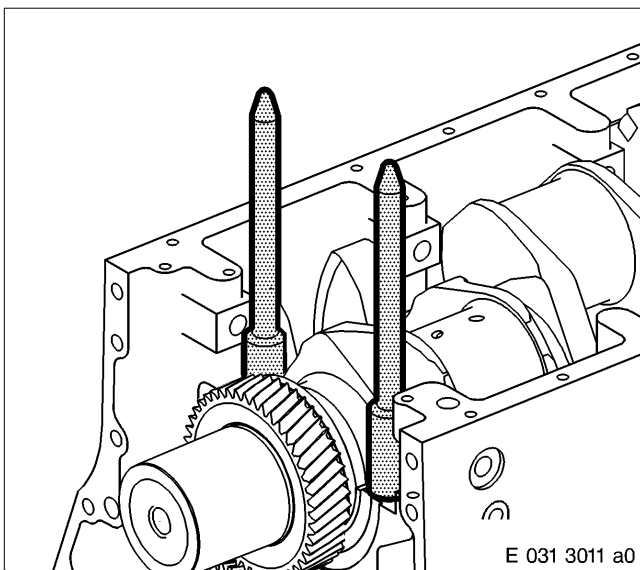

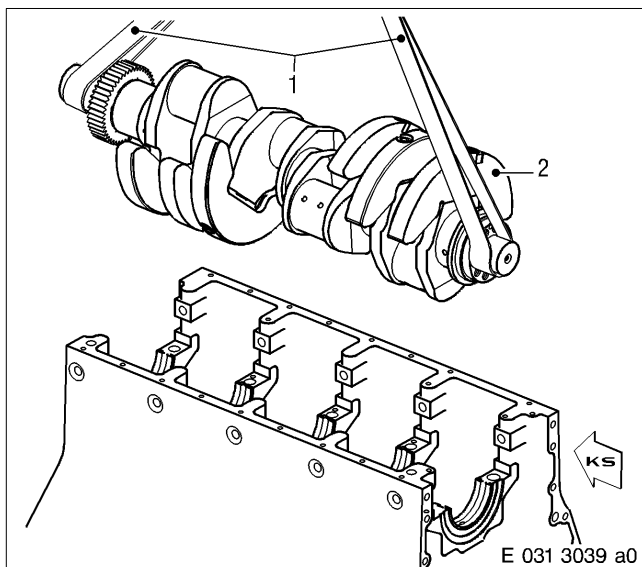

⚠ WARNING

**Suspended load.
Risk of injury!**
Only use lifting device provided by manufacturer and observe lifting instructions.
Never stand beneath a suspended load.

Using rope loops (1) and crane, raise crankshaft (2) clear of crankcase.

Take care to keep crankshaft horizontal.

Lower crankshaft onto sturdy assembly frame.

Remove assembly bolts.

Mark bearing shells on housing side to crankshaft bearing cap and remove from crankcase.

C 031.05.06 Disassembly

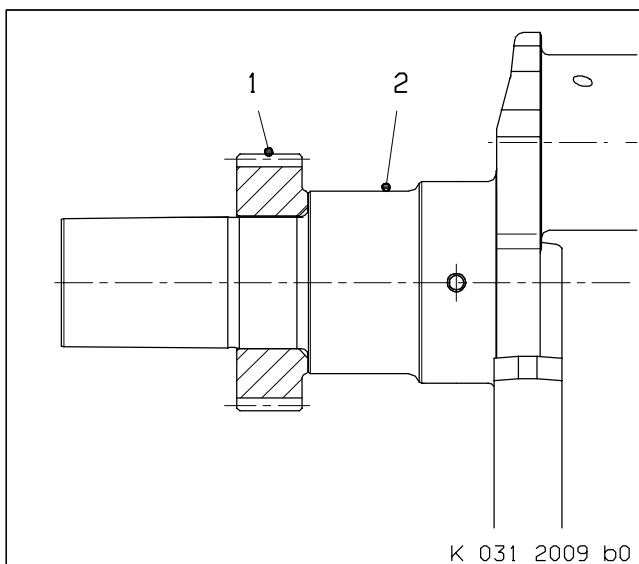

Removing crankshaft gear, free end

Note: Remove crankshaft gear (1) only if necessary (e.g. if damaged). Always consult MTU or DDC before removing crankshaft gear.

Using a suitable removal tool, remove crankshaft gear on free end from the crankshaft (2).

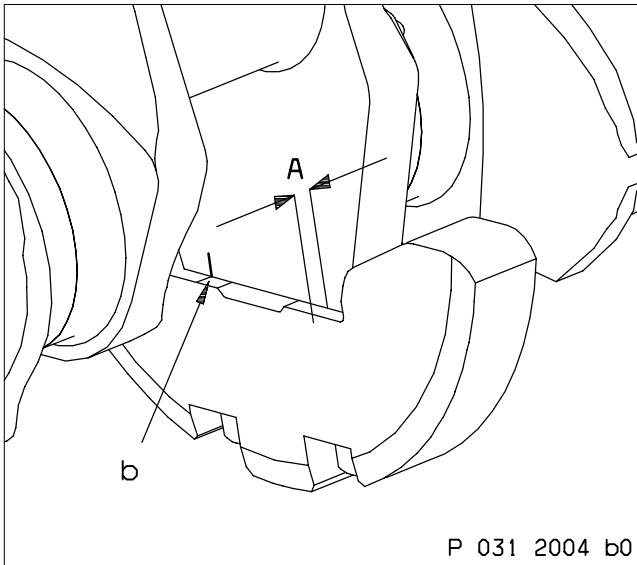

Removing counterweights

Note: If counterweights are removed after balancing, mark relevant counterweight in its installation position with regard to crankshaft beforehand.

Determine and record distance A (web to counterweight).

Apply mark b.

Check that counterweights are numbered in consecutive order; stamp new numbers if necessary.

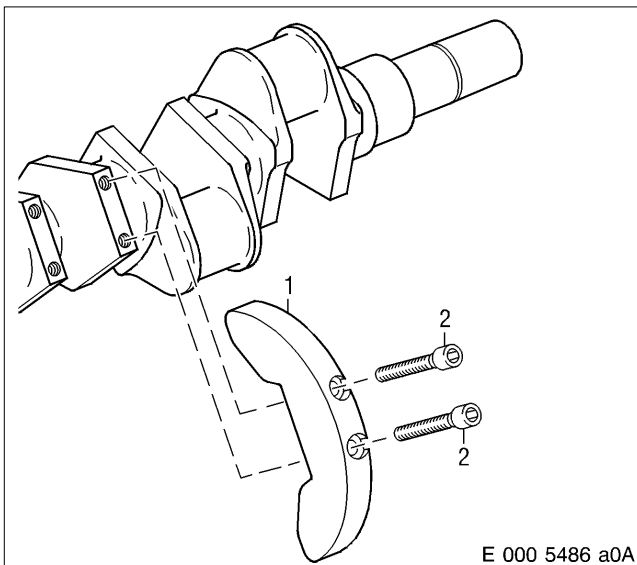

Note: Remove counterweights with crankshaft in a sturdy stand.

Remove screws (2) and counterweight (1).

C 031.05.08 Inspection and Repair

Cleaning and checking crankshaft

Clean crankshaft with cold cleaner.



CAUTION

Compressed air is air which has been compressed under pressure. If compressed air is used for blowing out or blow-drying components, always wear protective goggles or safety mask. Compressed air must not be directed at the body. Pressure must not exceed 3.0 bar (40 lb/in²).

Using suitable bottle brush and cold cleaner, thoroughly clean all crankshaft bores and blow through with compressed air.

Note: Never use a wire brush!

Check taper surface (free end) for scoring and damage.

Remove minor scoring and damage by polishing with emery cloth.

Check taper 1:50 with taper gauge.

If necessary, machine taper to MTU/DDC specifications.

Check that all threads are in perfect condition.

Check teeth of gear (free end) for wear, indentations and chipping.

Remove minor wear, indentations and scoring by rubbing down with emery cloth or an oilstone; replace gear if necessary.

Check counterweight mating faces for wear; machine-grind if necessary. It is imperative to contact MTU and/or DDC.

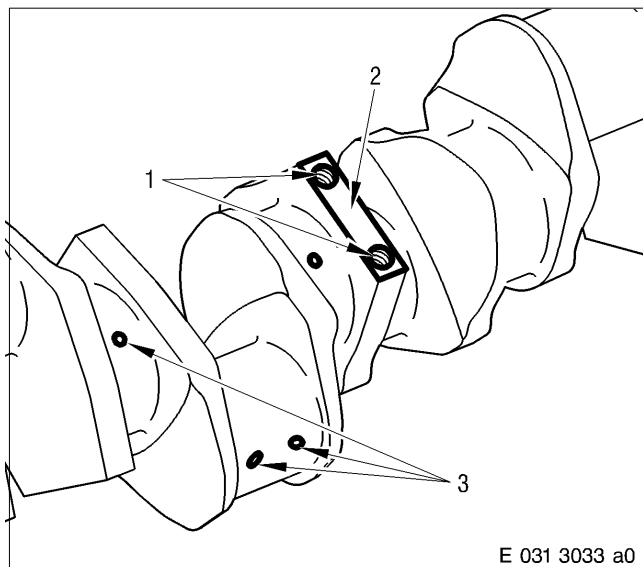

Checking crankshaft for cracks

Using the magnetic crack-testing method with fluorescent magnetic powder, check crankshaft for longitudinal and transverse cracks. Include oil bores and journal bores (3), journal transition radii, counterweight mating faces (2) and threaded bores (1) in scope of inspection.

Install crankshaft in longitudinal direction between jaws of test device.

For the test, a magnetic electric field strength of 20 A/cm to 60 A/cm must be applied at every part of the component.

Demagnetize crankshaft after crack-testing. The maximum permissible residual field strength after demagnetization is 2.5 A/cm to 4 A/cm.

Note: A component is considered sufficiently demagnetized when a paper clip suspended on a thread is no longer attracted by the component.

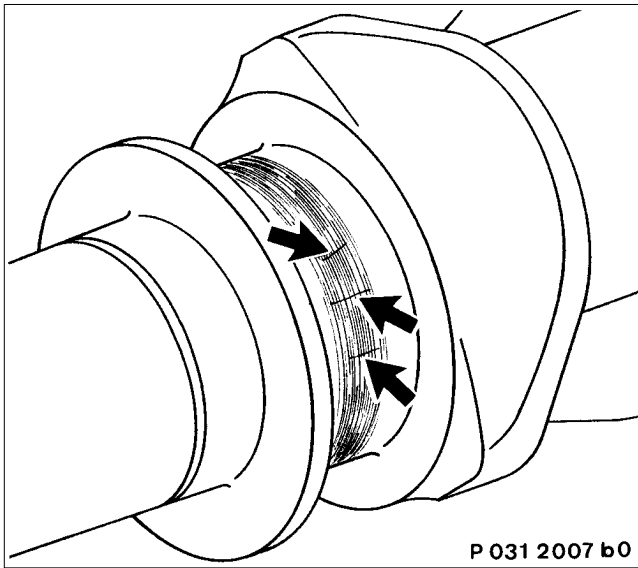

Information on thermal cracks

Characteristic of hot-running cracks is that they are almost always parallel to the axis of the component (see arrows).

Transverse cracks sometimes come out from these cracks. Heavy thermal cracks are mostly of a depth approximately corresponding to the thickness of the hardness layer. Replace crankshaft with such cracks.

Crankshafts exhibiting minor hot-running cracks can be repaired. This is provided that regrinding to a repair stage or local grinding will remove the damage. It is imperative to contact MTU and/or DDC.

Carefully regrind the affected bearing journals, according to crack depth, approximately to a permissible repair size. Minor cracks can also be repaired by local grinding.

Preliminary grinding must be carried out before the after-curing, otherwise there is the danger that the thermal cracks will increase in length and depth. Grind to specified repair stage only after bearing journals have been hardened.

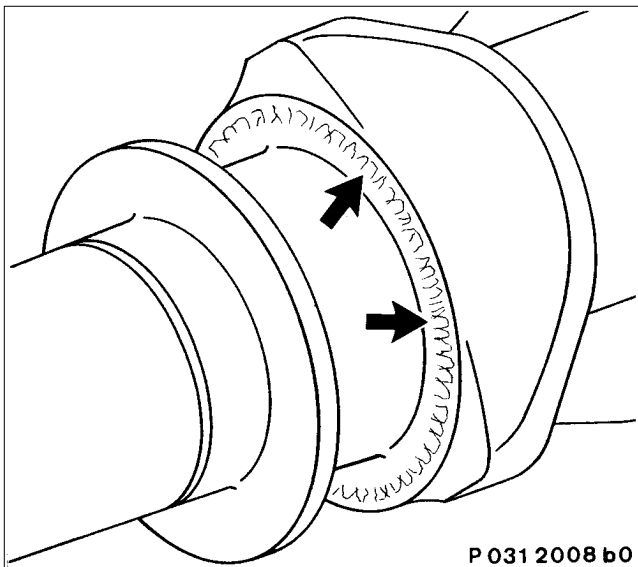

Information on grinding cracks

Fine branching is characteristic of thermal cracking, (arrows). The illustration shows a bearing journal with grinding cracks.

Replace crankshaft with such cracks.

Grind cracks occur on account of insufficient cooling during grinding or through excessive feed.

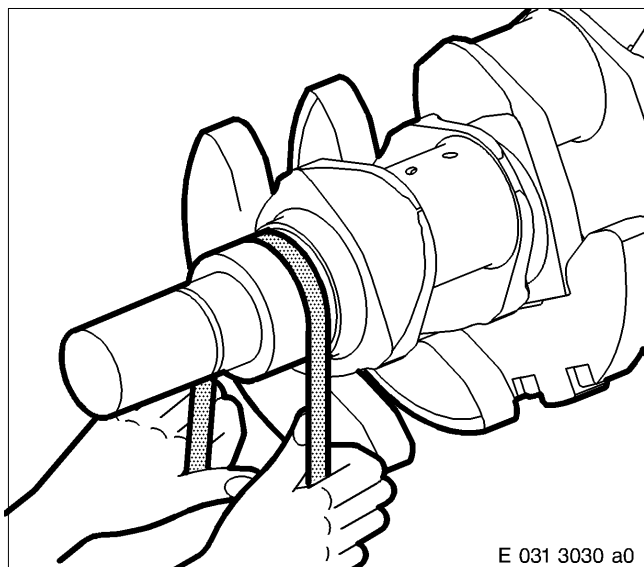

Checking crankshaft journal

Burnish all journals with emery cloth (granulation P 320).

Standardised roughness height (R_z) of journal sliding surface = $1 \mu\text{m}$

Polish all fillets and transitions.

Check main bearing and crankpin surfaces for scoring and damage. If necessary, regrind relevant journal to next repair stage.

Check friction washer sliding surface of first main bearing for wear. Regrind to next repair stage if necessary.

For limit values, see Tolerances and Wear Limits List.

Remove minor scoring and damage by polishing with emery cloth.

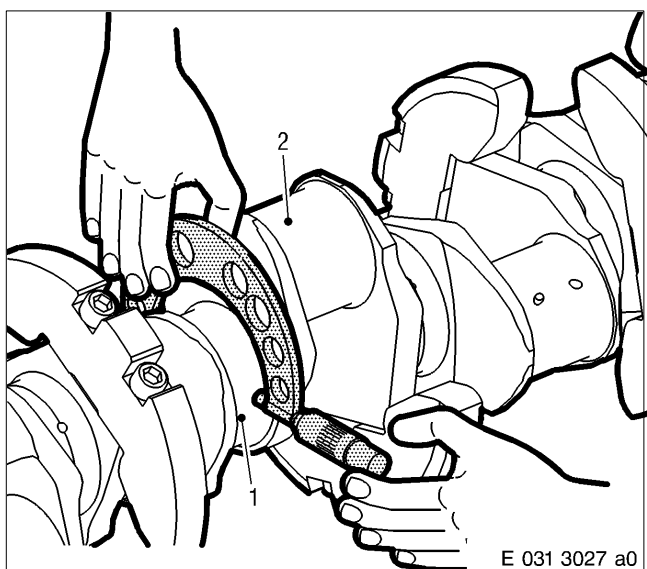

Measuring crankshaft journal

Using micrometer, measure bearing journals (1) and crankpins (2) of crankshaft for out-of-round and surface irregularities; record measured values in Data Sheet.

For limit values, see Tolerances and Wear Limits List.

If limit values are exceeded, grind crankshaft to next repair size.

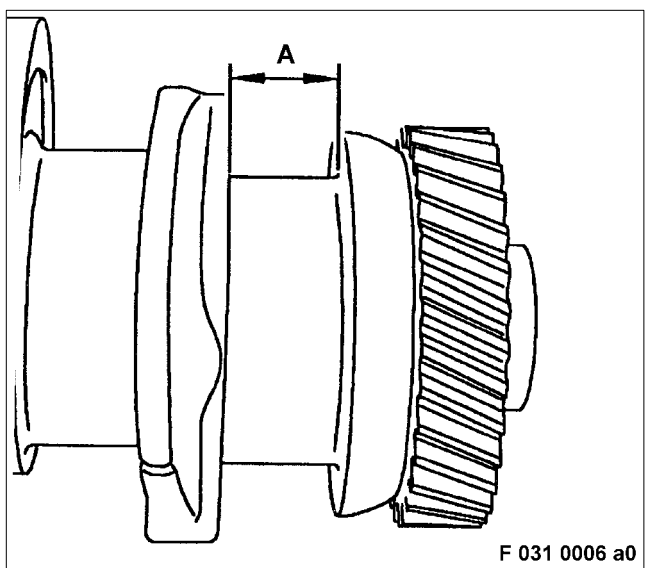

Measure width of alignment bearing with inside micrometer and enter values in Data Sheet.

For limit values, see Tolerances and Wear Limits List.

If limit values are exceeded, grind crankshaft to next repair size.

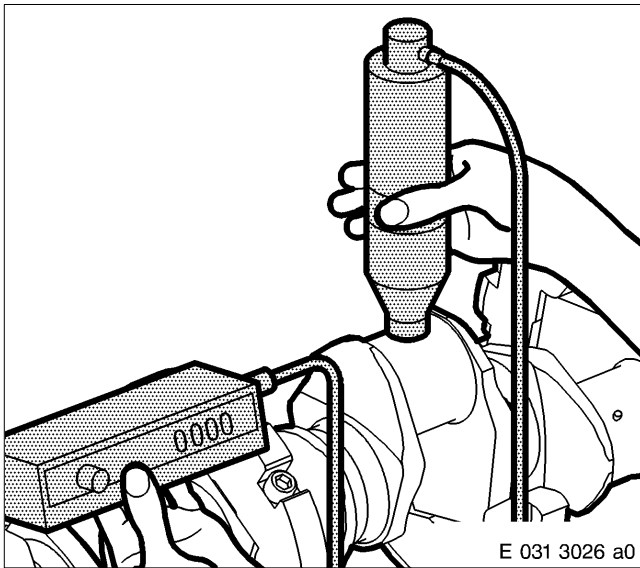

Checking hardness of journals

Check hardness of all journals using the Microdur tester or other suitable hardness tester.

Test hardness of each journal at four points at 90° intervals around circumference.

Specified hardness = from 49 HRC to 53 HRC

Rehardening is necessary if a bearing journal has lost its hardness on account of bearing scuffing.

Checking crankshaft concentricity

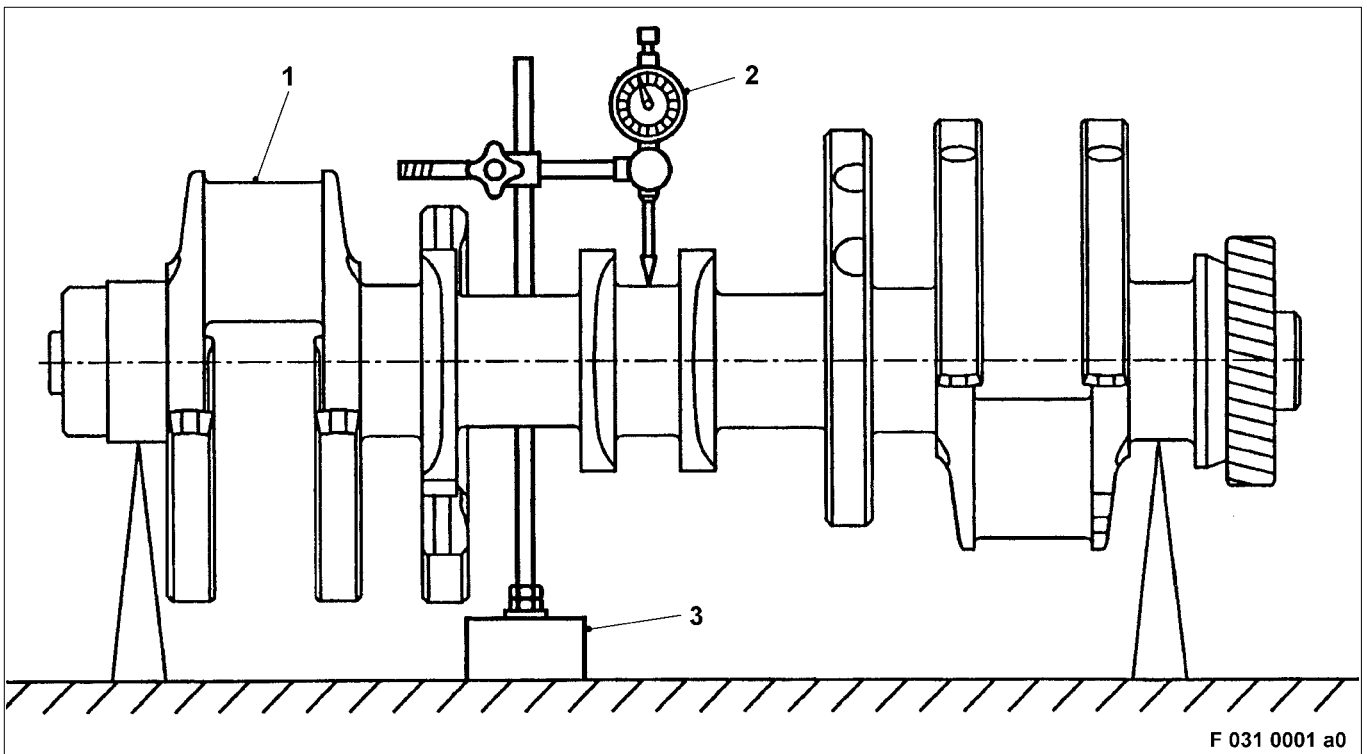

Place crankshaft (1) on the outer bearing journals.

Using a magnetic-base indicator holder (3) and dial gauge (2), check concentricity of bearing journals.

If wear across circumference of journal is irregular, check at transition from cylindrical section of journal to radius. For limit values, see Tolerances and Wear Limits List.

If measured values differ from those specified in Tolerances and Wear Limits List, grind relevant journals to next repair stage.

Note: Do not straighten crankshaft after hardening!

Always consult MTU/DDC before hardening and grinding journals of crankshaft.

Regrinding crankshaft

Only journals which are not dimensionally stable must be reconditioned to next repair stage.

When regrinding, make every effort to remove only as much material as is required to achieve next repair size.

Adhere strictly to all specifications for sizes and tolerances.

This also applies to transition radii and surface finish.

Record main bearing journal and crankpin diameters, guide bearing width, concentricity values and journal hardness values in Crankshaft Data Sheet.

Thoroughly clean oil bores after grinding.

Necessary checks after grinding:

- Check dimensions and surface finish of all bearing journals
- Check radii at bearing journals
- Check that oilway bores are correctly radiused and polished;
perform this check with meticulous care, in order to prevent damage to the bearing shells
and ensure adequate lubrication.
- Check concentricity and axial runout
- Check hardness
- Check for cracks

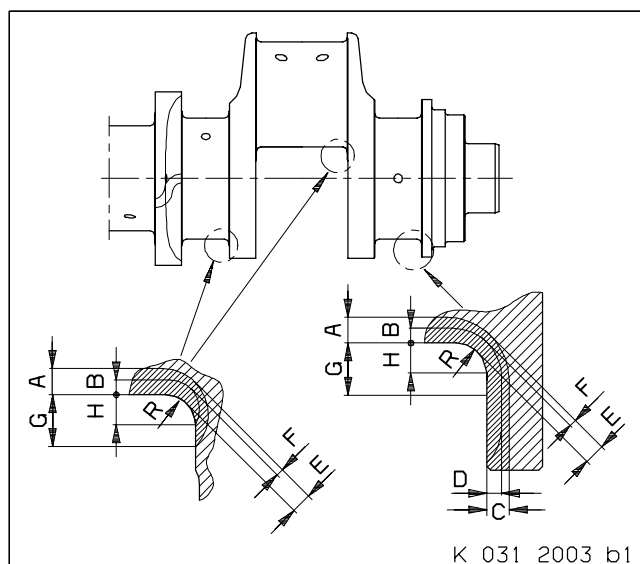

Hardness transient across journal

A = 3.5 mm (Max. hardened zone depth)

B = 2 mm (Min. hardened zone depth)

C = 3 mm (Max. hardened zone depth)*

D = 2 mm (Min. hardened zone depth)*

E = 2.8 mm (Max. hardened zone depth at radius area)

F = 1.8 mm (Min. hardened zone depth at radius)

G = 7 mm (Max. hardened zone height at radius)

H = 4 mm (Min. hardened zone height at radius)

R = from 3.5 mm to 4 mm

Maximum peak-to-valley height at radii = 6 μm

*only alignment bearings

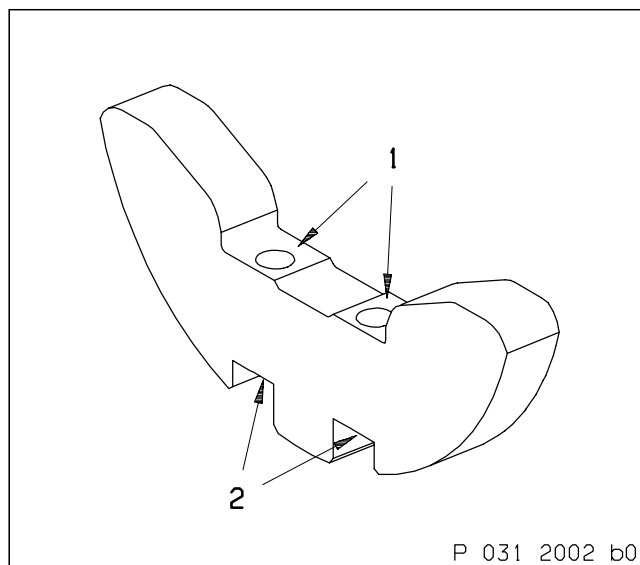

Checking counterweights

Using the magnetic crack-testing method with fluorescent magnetic powder, check counterweight for cracks.

If cracks are detected, replace counterweight.

Check crankshaft mating face (1) for wear; machine-grind if necessary.

It is imperative to contact MTU and/or DDC.

Using engineer's blue, check contact pattern of mating face (2) for stress bolt heads; remove surface irregularities as necessary.

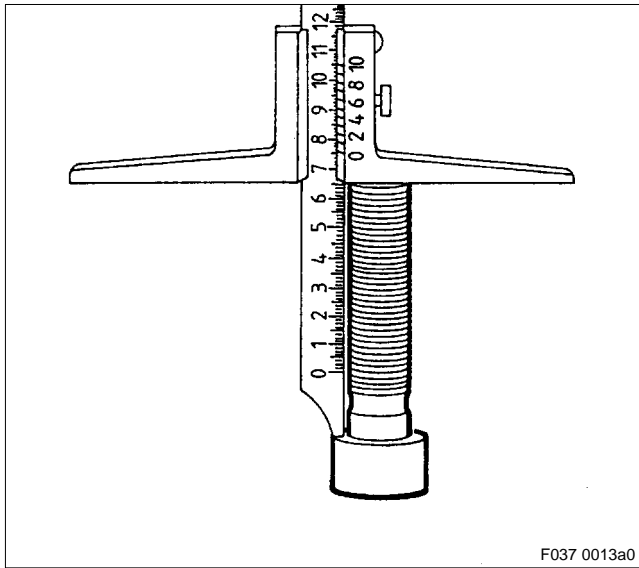

Checking screws for counterweights

Measure shaft length of screws with depth gauge; max. permissible shaft length – see C 031.05.01. Replace screws if necessary.

Using the magnetic crack-testing method with fluorescent magnetic powder, check screws for cracks.

Replace screw if cracks are found.

Make sure that threads are in perfect condition.

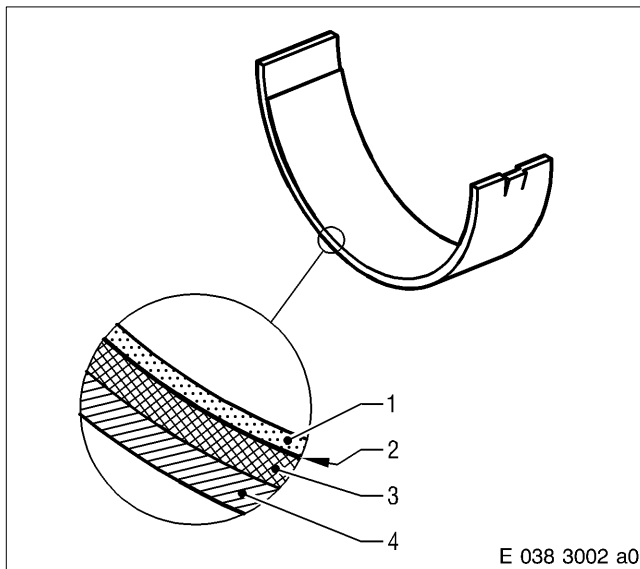

Checking and assessing crankshaft bearing shells

Note: Upper and lower bearing shells have different item numbers (different designs).

Replace bearing shells as part of every W6 overhaul.

Check bearing shells for surface wear, scoring, crack, corrosion, erosion and damage; replace if necessary.

Bearing shell has the following material structure:

- 1 Sliding layer (from 12 µm to 20 µm)
- 2 Intermediate layer (nickel barrier)
- 3 Bearing metal
- 4 Steel support shell

An important indicator for assessing extent of wear on bearing shell is the shape and extent of the nickel barrier areas exposed.

Usability of bearing shell is restricted at 70 % of sliding layer in friction area!

Note: It is often difficult to differentiate between the hard nickel barrier and softer sliding layer. If in doubt, consult a bearing specialist.

Check condition bearing shell butt and bearing reverse side and check for friction corrosion (pitting); if there is evidence of friction corrosion, replace bearing shell and determine cause.

Possible causes: Screws not sufficiently pre-tensioned, assembly fault, bearing shell spread dimension is outside tolerance limit and defective bearing support bore.

Measure bearing shells spread dimension.

If spread dimension is too low (see Tolerances and Wear Limits List), replace bearing shells.

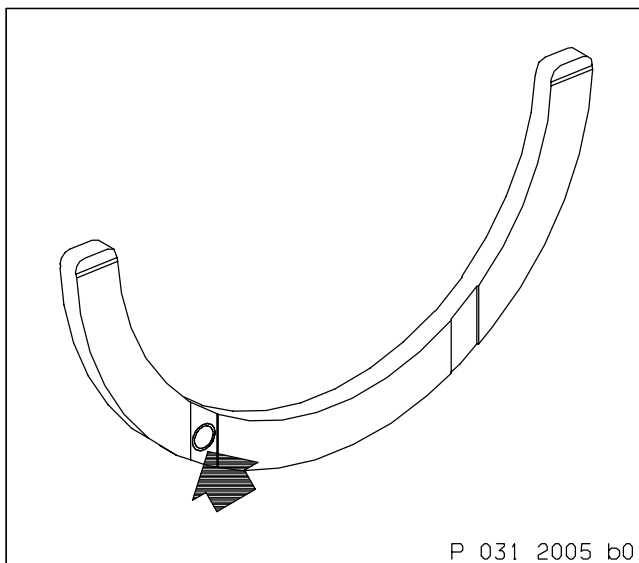

Checking friction washers

Replace friction washers during W6 overhaul.
Check friction washers for scoring and damage and replace if necessary.
Check steel bush (arrow) is securely seated and check bore for wear. Replace friction washer if necessary.

Dynamic balancing

Prior to balancing, seal all oilways to prevent the ingress of foreign matter.

Place crankshaft in the shaft journals 1 and 5.

For dynamic balancing, attach counterweight to each crankpin.

Counterweight G = 10800 g ± 10 g

Mass of balancing group: 286 kg

Max. operating speed:	2300 rpm
Balancing speed:	150 rpm
Permissible residual imbalance per balancing plane for initial balancing:	60 gcm
Permissible residual imbalance per balancing plane for comparative balancing in different configuration or balancing machine:	160 gcm

Remove material to balance crankshaft only from counterweights by drilling radially with twist drill.
For specified bore values – see following illustration.
After balancing, recheck numbers on counterweights and renumber if necessary.

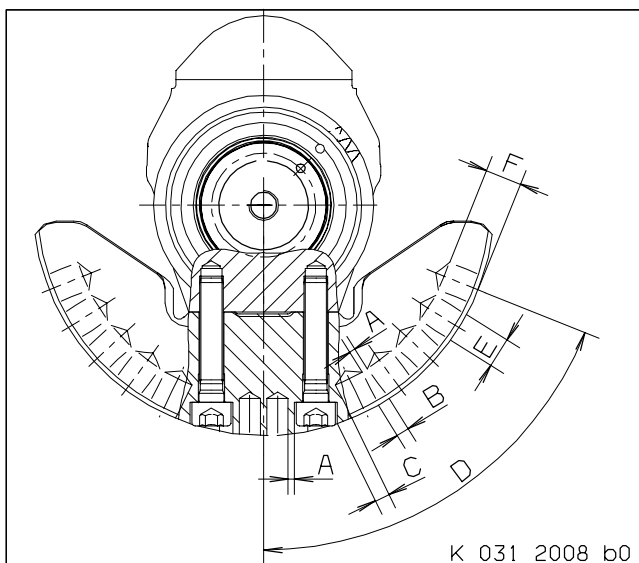

Bore values at counterweights

- A = 4 mm (min.)
 - B = 9 mm (min.)
 - C = 10.3 mm (min.)
 - D = 72° (max.)
 - E = 22 mm (max. bore diameter)
 - F = 25 mm (max. bore depth)
- Max. bore diameter of the balancing bores between securing screws, as required:
- with one bore = 22 mm
 - with two bores = 14.5 mm
- Minimum wall strength around balancing bores:
4 mm

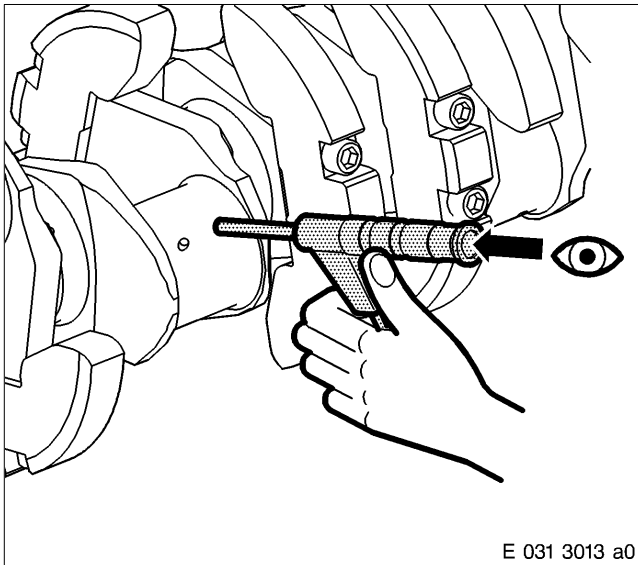

Checking oil bores

Endoscopically inspect all oilways with cold light source and make sure they are perfectly clean.

If necessary, clean oil bores.

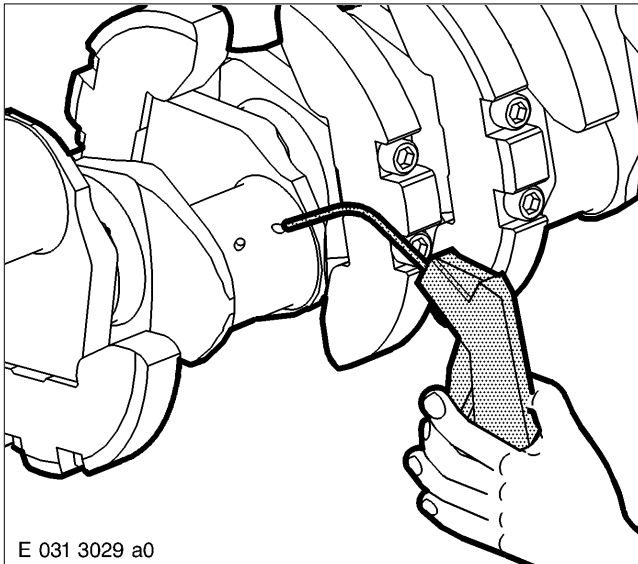

Cleaning oil bores

Thoroughly clean crankshaft oilways with cold cleaner and suitable bristle brush.

Note: Never use a wire brush!

CAUTION

Compressed air is air which has been compressed under pressure. Risk of injury.

If compressed air is used for blowing out or blow-drying components, always wear protective goggles or safety mask.

Compressed air must not be directed at the body. Pressure must not exceed 3.0 bar (40 lb/in²).

After cleaning, flush bores with cleaner (under pressure if possible) and blow clear with compressed air.

Note: If the crankshaft is not installed or put into operation immediately afterwards, dry the oil bores, preserve and seal air-tight using suitable end covers.

Crankshaft mounting

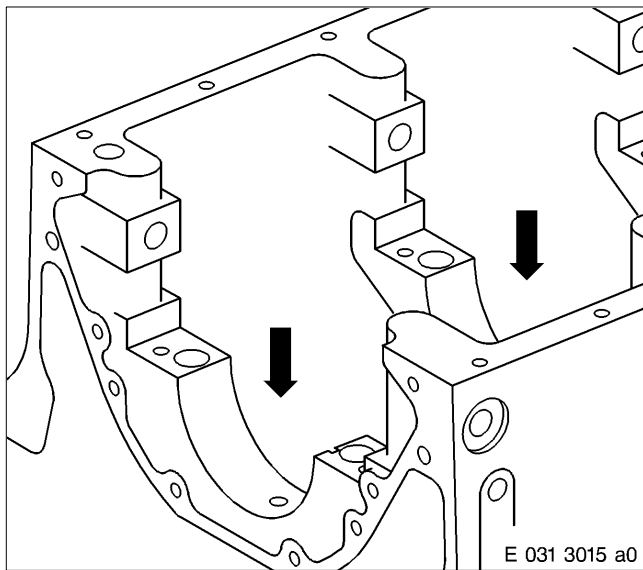

Installing bearing shells

Note: Always make sure that all components are perfectly clean.

Crankcase is upside down, with oil pan mating face horizontal.

Wipe bores (arrows) for crankshaft bearing in crankcase and bearing shells on both sides.

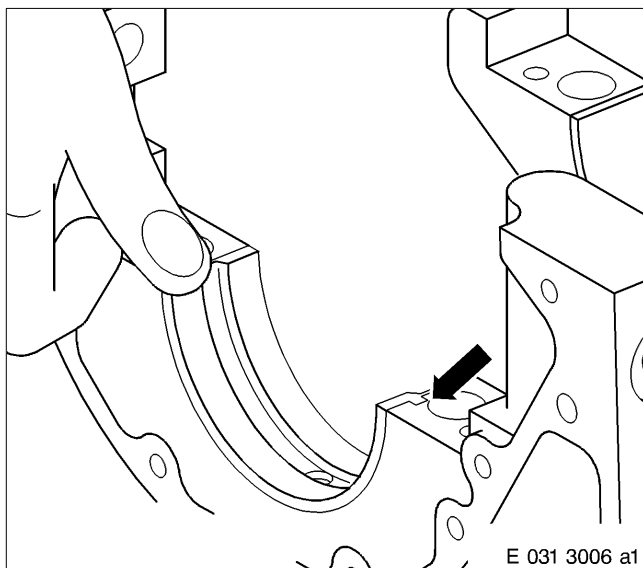

Note: Top and bottom bearing shells have different part numbers.

Check codes for repair stage and journal diameter on new bearing shells and bearings numbers on run-in bearing shells.

Compare crankcase inspection sheet with crankshaft data sheet.

Manually insert bearing shells (bearing shells with oil groove and oil bore) on housing side in accordance with bearing number into housing bore to form a positive connection.

Securing lug (arrow) of bearing shell must sit in groove in crankcase.

Oil bores in bearing shells and crankcase must be aligned.

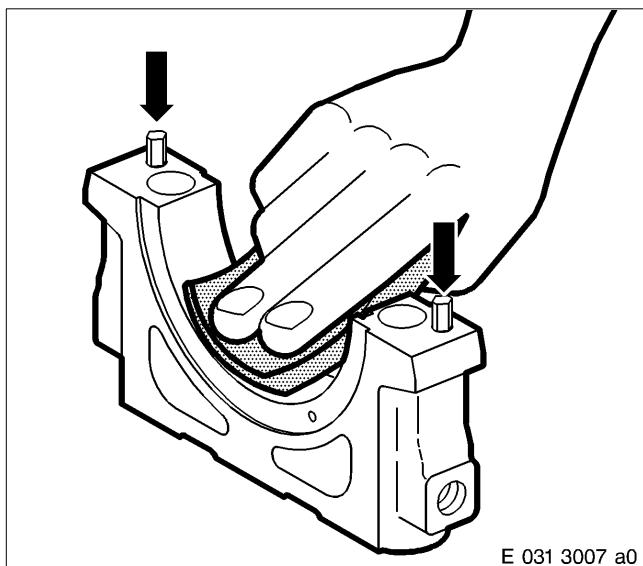

Installing main bearing caps

Wipe bearing shell mating faces on main bearing cap.

CAUTION

Compressed air is air which has been compressed under pressure. Risk of injury!
If compressed air is used for blowing out or blow-drying components, always wear protective goggles or safety mask.
Compressed air must not be directed at the body.
The pressure must not exceed 3.0 bar (40 lb/in²).

Blow out partitions on crankshaft bearing cap and crankcase, cylinder and dowel pins (arrows) and related bores in crankcase with compressed air and check that they are perfectly clean.

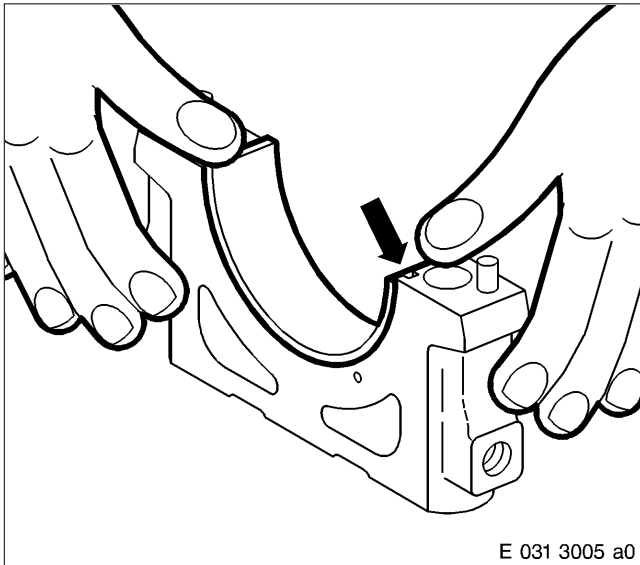

Wipe bearing shell on both sides and insert into main bearing cap according to markings or bearing number.

Securing lug (arrow) of bearing shell must sit in groove in crankshaft bearing cap.

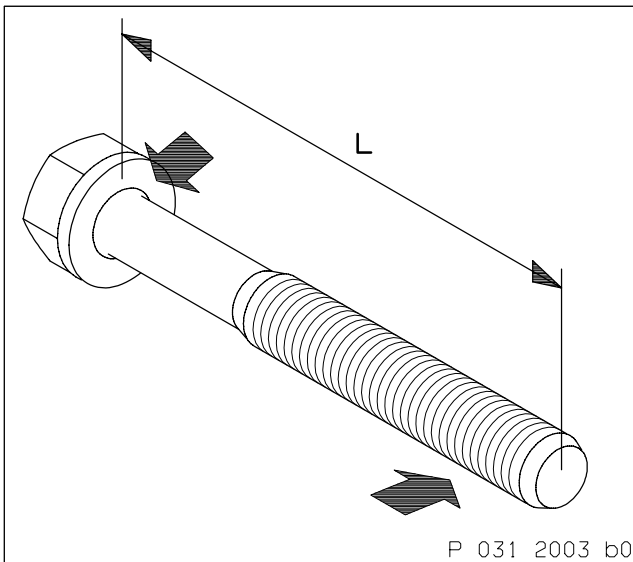

Measure shaft length (L) of central hex screw for crankshaft bearing cap. For max. shaft length – see C 031.05.01.

Coat thread and screw head mating face of centre hex screws (arrows) with engine oil.

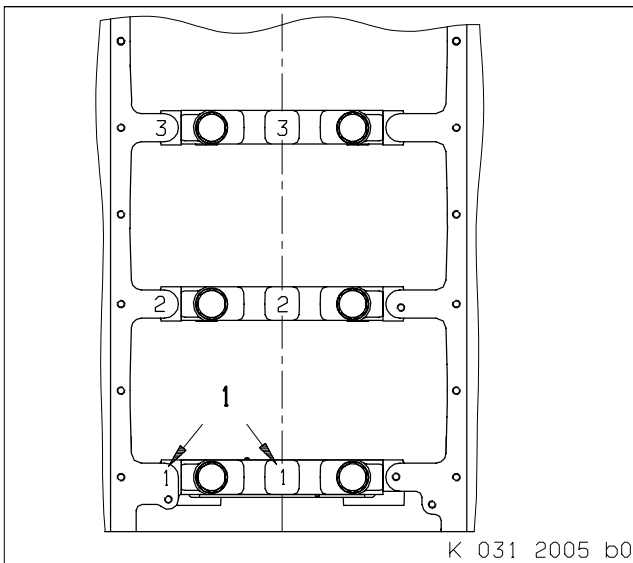

Note: Main bearing caps must not be interchanged!

⚠ CAUTION

**Components have sharp edges.
Risk of injury!
Handle components only when wearing protective gloves.**

Match bearing cap in accordance with crankcase marking (1) to bearing cap and insert into crankcase.

1 – Starting at driving end, stamp number of main bearing with 6 mm numbers main bearing so that they can be read from same direction.

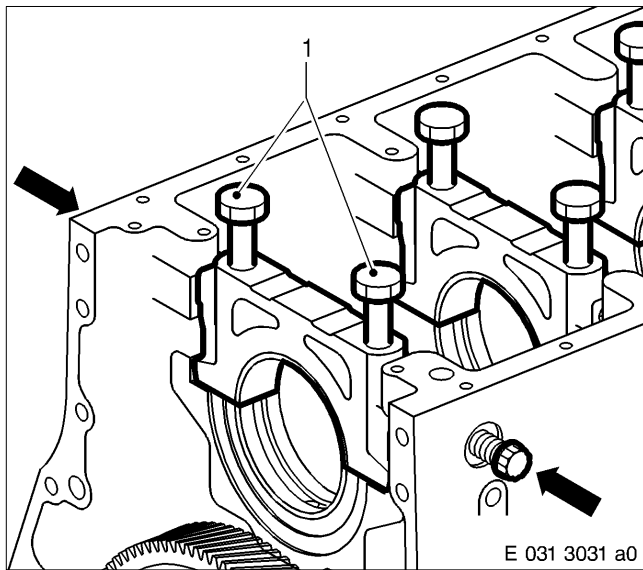

Insert centre hex screws (1) into position.
Coat thread and mating face of side double-hex screws (arrows) with engine oil and insert double-hex screws but do not tighten yet.

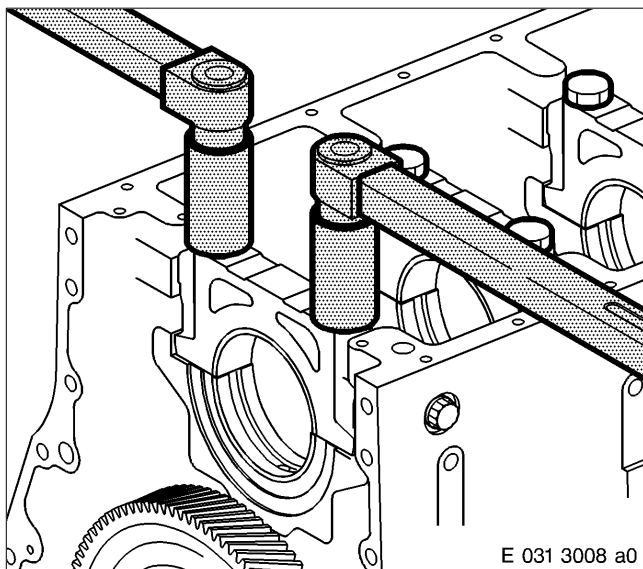

Note: Always tighten screws on one bearing at same time.
Tightening sequence starts from alignment bearing.

Pretighten central screws to specified pretightening torque – see C 031.05.01.

Mark screw heads.

Simultaneously tighten screws on one bearing according to specified angle of further rotation.

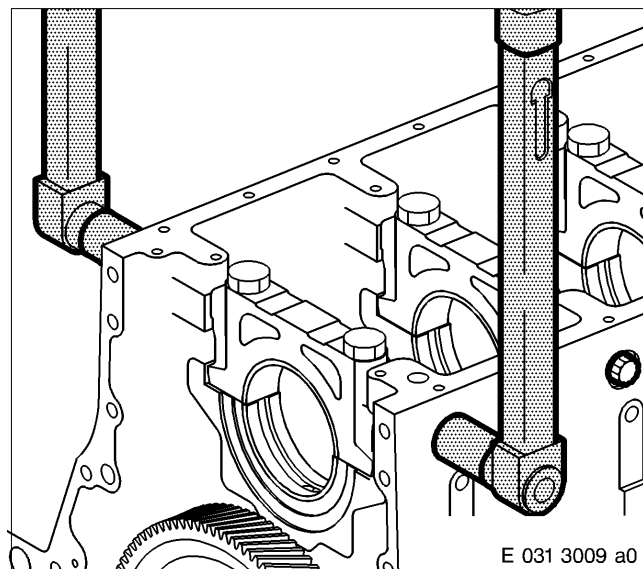

Note: Tighten screws on one bearing at same time.
Tightening sequence starts from alignment bearing.

Tighten side double hex screws to specified torque – see C 031.05.01.

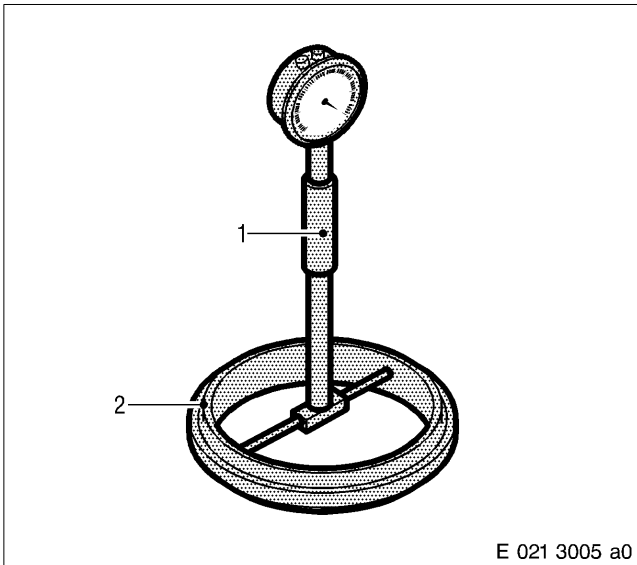

Measuring crankshaft bearing I.D.

Adjust bore gauge (1) and dial gauge with micrometer or gauge ring (2) to basic size for crankshaft bearing bore as per Tolerances and Wear Limits List.

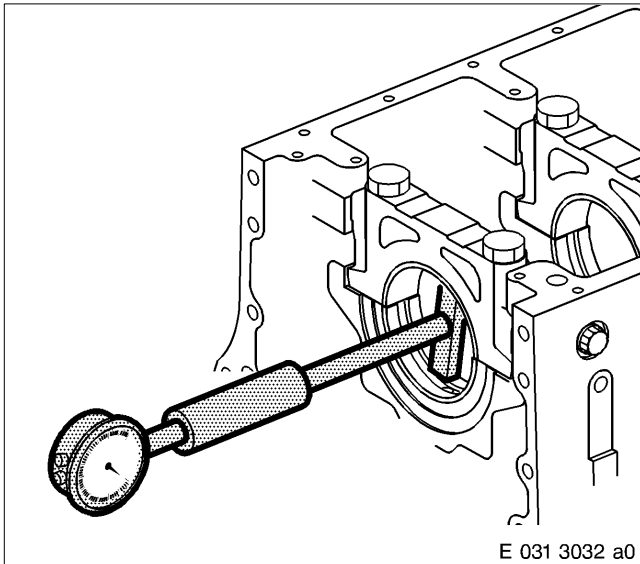

Coat running faces of crankshaft bearing shells with engine oil.

Measure running crankshaft main bearing bore with bore gauge.

Enter measurement values in data sheet.

For measuring points and limit values, see Tolerances and Wear Limits List.

Replace bearing shells or use repair-size bearings if limit values are exceeded.

After measuring crankshaft bearing bore, if necessary mark bearing shell according to bearing shell number.

Note: Release screws on one bearing at same time.

Remove side double-hex screws and then central hex bolts in reverse sequence as to when tightening.

CAUTION

**Components have sharp edges.
Risk of injury.
Touch components only when wearing protective gloves.**

Remove bearing cap and bearing shells.

Note: Protect bearing shells from damage!

C 031.05.10 Assembly

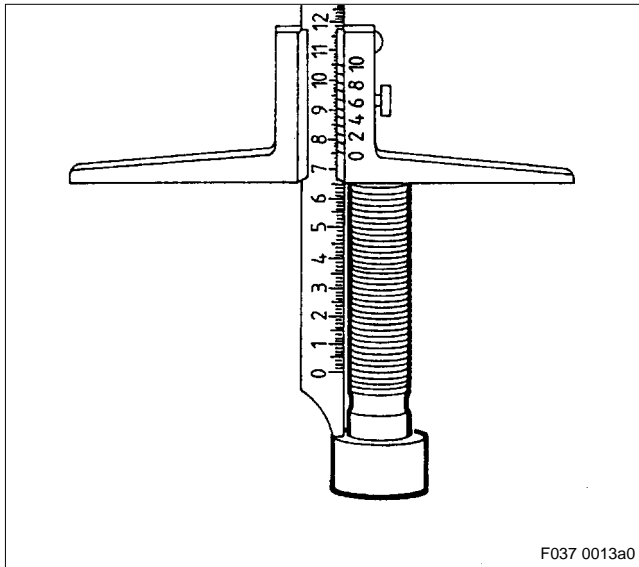

Installing counterweights

Measure shaft length of screws for counterweights;
for max. shaft length – see C 031.05.01.

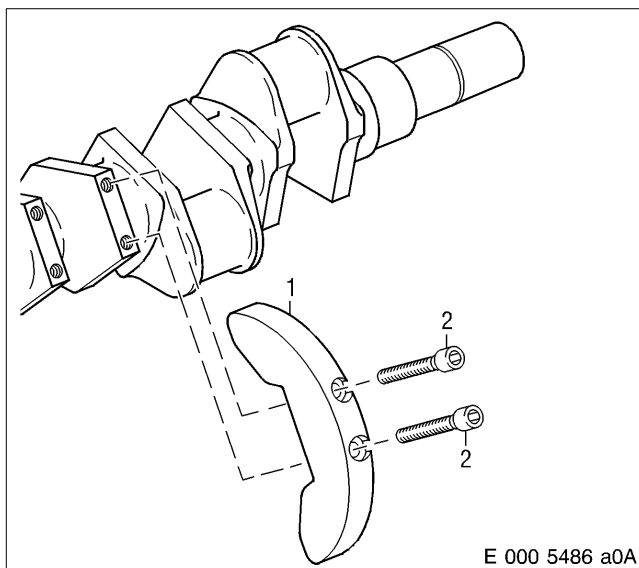

Clean and degrease mating face on crankshaft and counterweight (1).

Coat threads and screw head mating face of screws (2) with engine oil.

Note: Install counterweights in accordance with markings.

Fit counterweight on crankshaft and tighten slightly with screws.

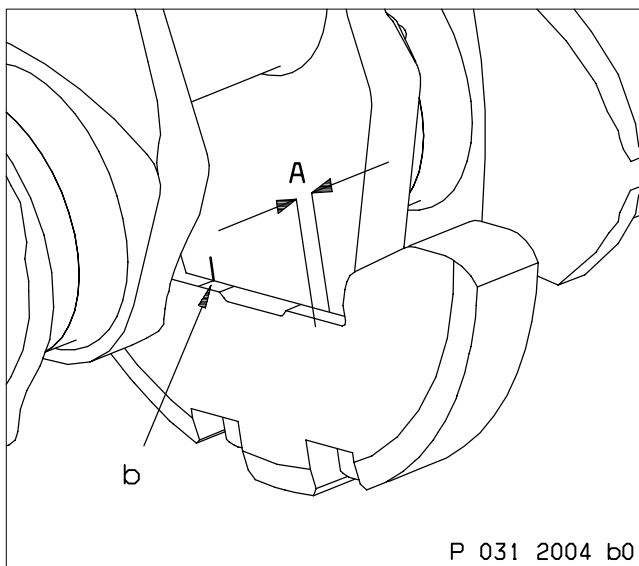

Align counterweight to marking b and dimension A measured before disassembly.

$A = 12 \text{ mm} \pm 0.2 \text{ mm}$

Pretighten screws to specified pretightening torque – see C 031.05.01.

Check that marks applied prior to disassembly and measured distances are correct.

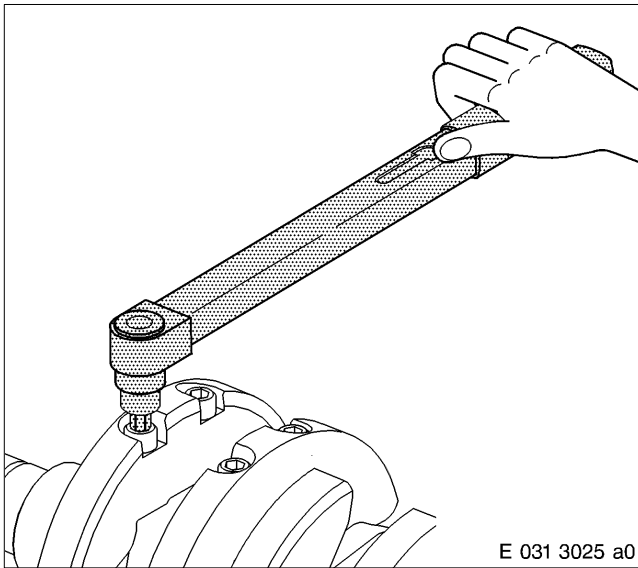

Mark screw heads.

Tighten screws through specified angle of further rotation.

After installing counterweights, recheck identification marks on counterweights and webs.

Note: If new counterweights have been installed, dynamically balance crankshaft. Also apply identification numbers to counterweights using punch numerals and beginning at driving end.

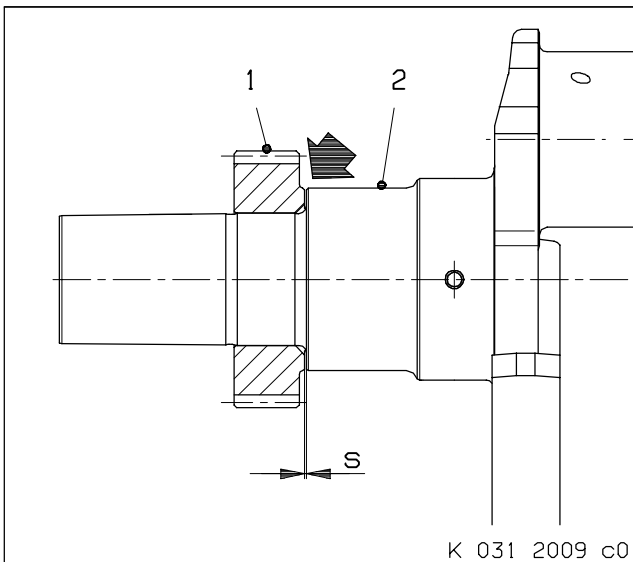

Installing crankshaft gear, free end

Clean and degrease surface of main journal and gear bore.

Heat crankshaft gear, free end (1) with heating unit to approx. 220 °C + 20 °C.

CAUTION

**Component is hot.
Risk of injury!
Touch components only when wearing protective gloves.**

Adjust distance (S) between crankshaft (2) and crankshaft gear, free end with feeler gauge.

Specified distance $S = 0.2 \text{ mm} \pm 0.2 \text{ mm}$

Place heated crankshaft gear (free end) to specified dimension on crankshaft, taking care that the installation position of the basil (arrow) is correct.

Once the components have cooled to room temperature, check distance (S).

C 031.05.11 Installation

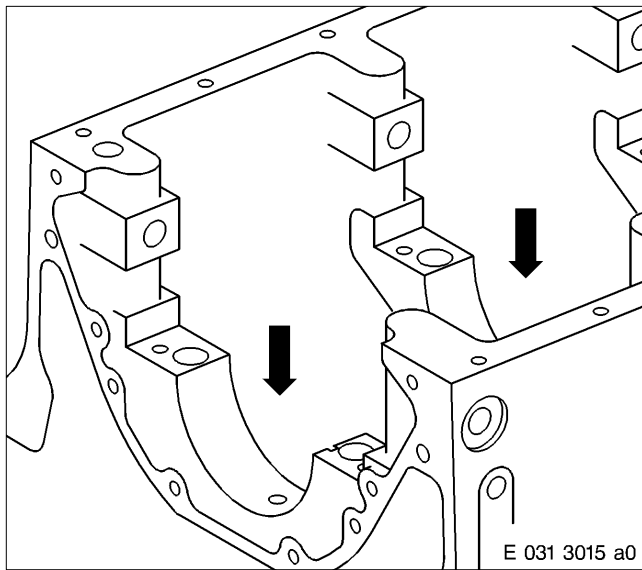

Installing crankcase bearing shells

Note: Always make sure that all components are perfectly clean.

Crankcase is upside down, with oil pan mating face horizontal.

Wipe bores for crankshaft bearing in crankcase and bearing shells on both sides.

Light up oil bores (arrows) to main bearings in crankcase with cold light and check that they are perfectly clean.

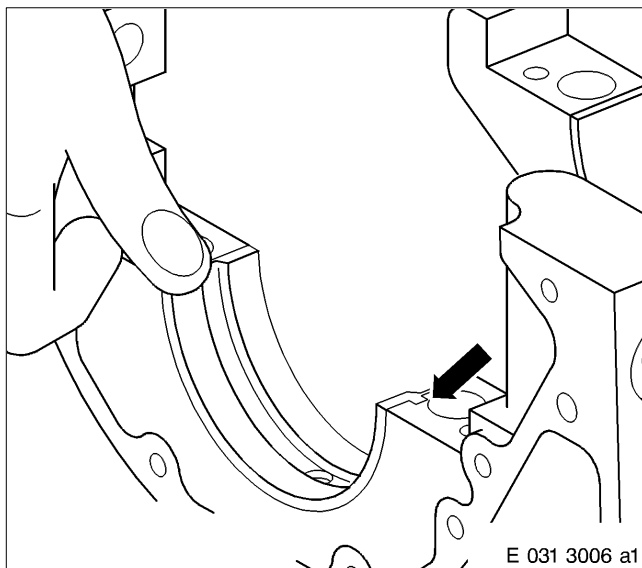

Note: Top and bottom bearing shells have different part numbers.

Insert bearing shells (bearing shells with oil groove and oil bore) in housing bore according to bearing numbers by hand to form a positive connection.

Check repair stage of crankshaft main bearing bore and repair stage of bearing shells – see crankcase data sheet and crankshaft characteristics record.

Securing lug (arrow) of bearing shell must sit in groove in crankcase.

Oil bores in bearing shells and crankcase must be aligned.

Spray running faces of crankcase bearing shells with engine oil.

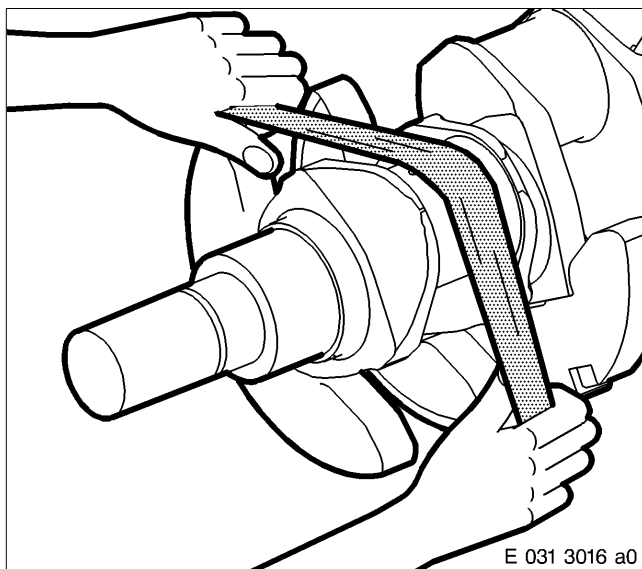

Installing crankshaft

Wipe crankshaft bearing surfaces.

Inspect oil bores with lamp and ensure they are perfectly clean.

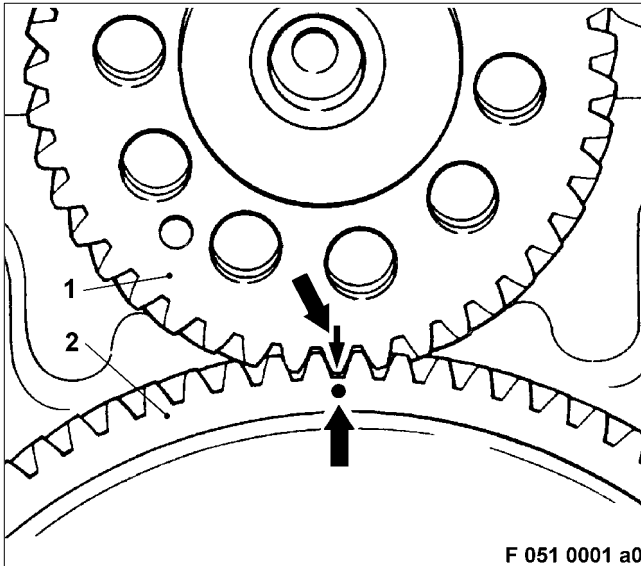
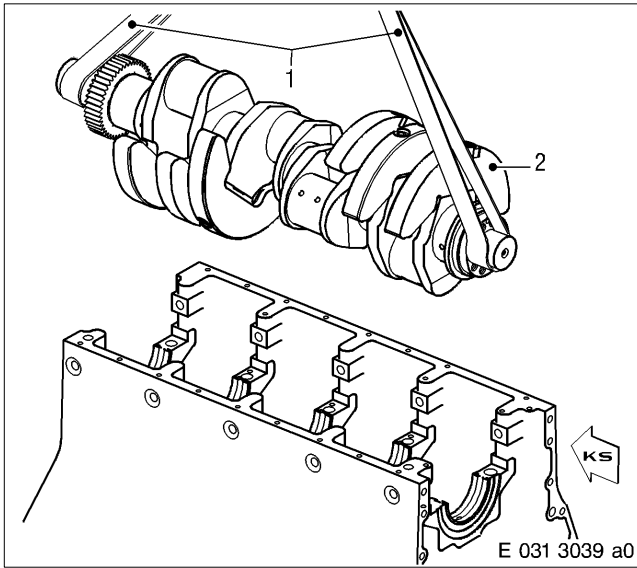

! WARNING

**Suspended load.
Risk of injury!
Only use lifting device provided by manufacturer and observe lifting instructions.
Never stand beneath a suspended load.**

Lift crankshaft (2), using rope slings (1) and crane.
To protect crankshaft, insert four assembly screws on first and last bearing.

Align crankshaft horizontally and vertically with line of bores in crankcase and gradually lower crankshaft.

With the camshaft installed, before the crankshaft reaches its end position in the bearing shells, ensure that the markings (arrows) on the crankshaft gear (1) and the camshaft gear (2) are aligned.

Carefully lower crankshaft into bearing shells.
Remove assembly screws.

Note: Do not rotate the crankshaft until the axial alignment bearing has been installed.

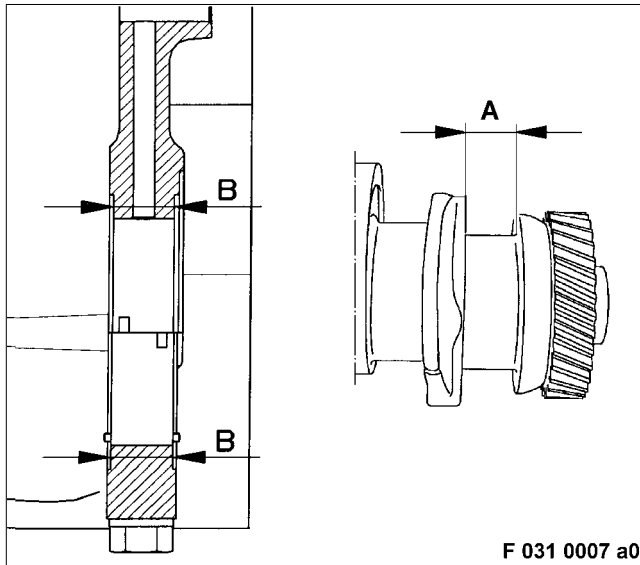

Determining wall thickness of friction washers

In order to achieve specified axial clearance in accordance with Tolerance and Wear Limits List after crankshaft is installed, thickness of friction washers must be determined as follows.

Measure and record alignment bearing width A of crankshaft.

Measure and record crankshaft alignment bearing cover thickness and crankcase web thickness B at fit for friction washers.

To calculate friction washer wall thickness:

$$\text{Wall thickness} = (A - B + \text{mean axial clearance}) : 2$$

Note: Friction washers of equal thickness must be installed on both crankshaft alignment bearing sides.

Friction washers are ready for installation ex works and also delivered in larger sizes for purposes of repair.

No reconditioning must be carried out!

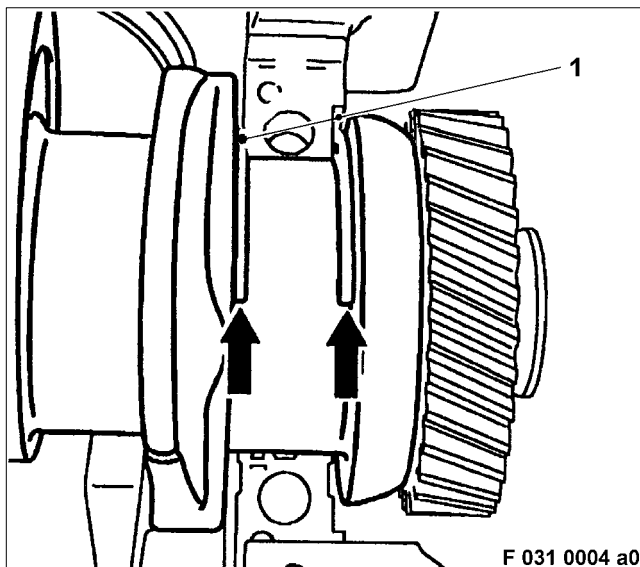

Installing upper friction washer halves

Coat friction washers (1) with engine oil and slide (arrows) into guides between crankshaft alignment bearing and mating face in crankcase on both sides of first bearing.

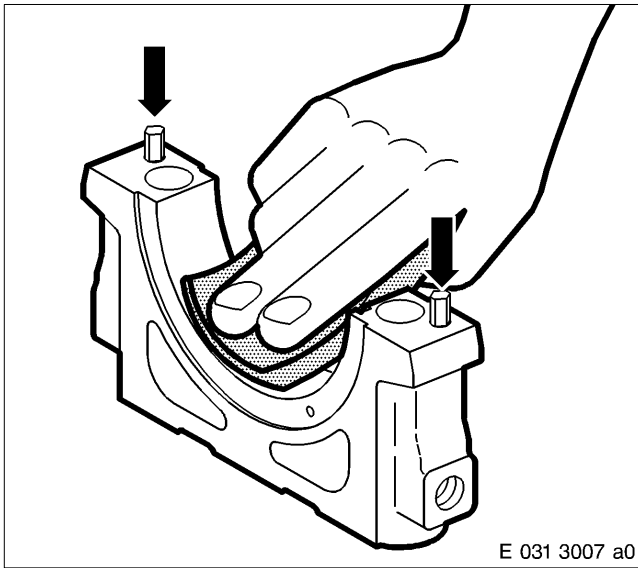

Installing main bearing caps

Wipe bearing shell mating faces on crankshaft bearing cap.

CAUTION

Compressed air is air which has been compressed under pressure. Risk of injury. If compressed air is used for blowing out or blow-drying components, always wear protective goggles or safety mask. Compressed air must not be directed at the body. Pressure must not exceed 3.0 bar (40 lb/in²).

Blow out partitions on crankshaft bearing cap and crankcase, cylinder and dowel pins (arrows) and related bores in crankcase with compressed air and check that they are perfectly clean.

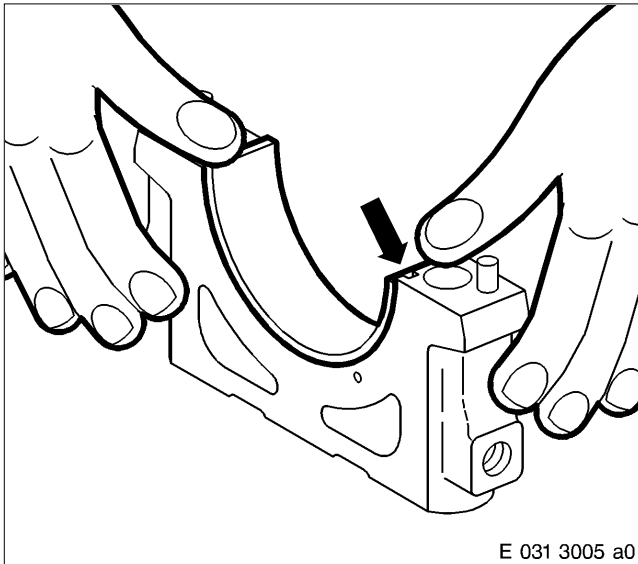

Wipe bearing shell on both sides and insert into crankshaft bearing cap according to bearing number.

Securing lug (arrow) of bearing shell must sit in groove in crankshaft bearing cap.

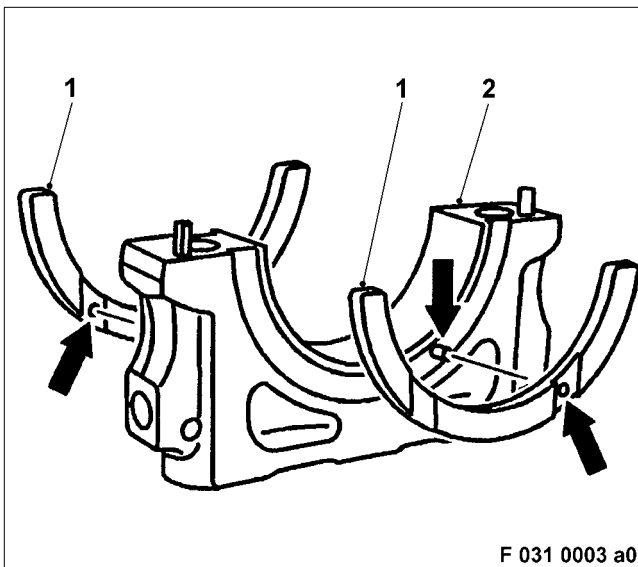

Coat friction washers (1) with engine oil.

Install friction washers on both sides of crankshaft alignment bearing cover (2), ensuring that grooved pin fit (arrows) is not damaged.

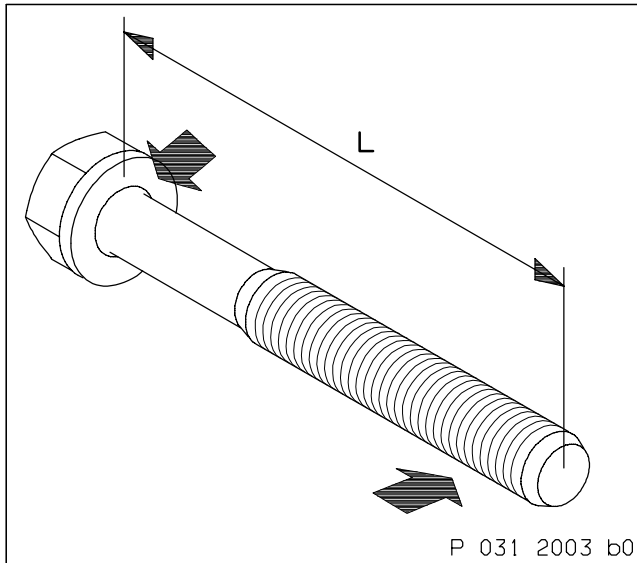

Measure shaft length of central hex screws for crankshaft bearing cap. For max. shaft length (L), see C 031.05.01.

Coat thread and screw head mating face of centre hex screws (arrows) with engine oil.

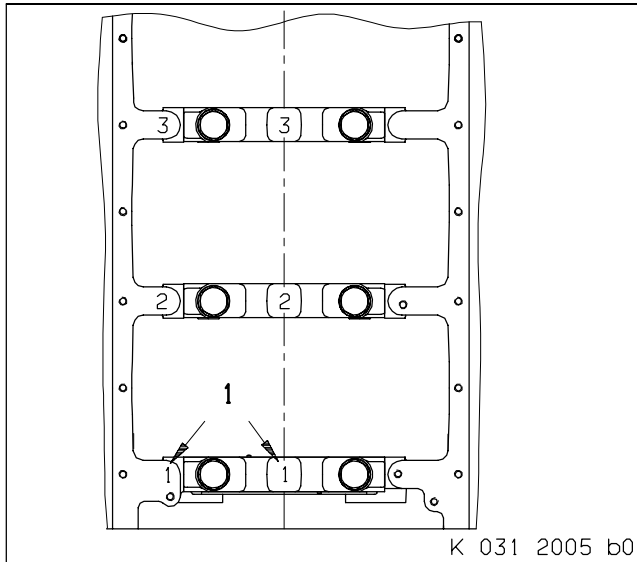

Note: Crankshaft bearing caps must not be interchanged!

Assign bearing cap in accordance with marking to crankcase of respective bearing.

1 – Starting at driving end, stamp number of main bearing with 6 mm numbers so that they can be read from same direction.

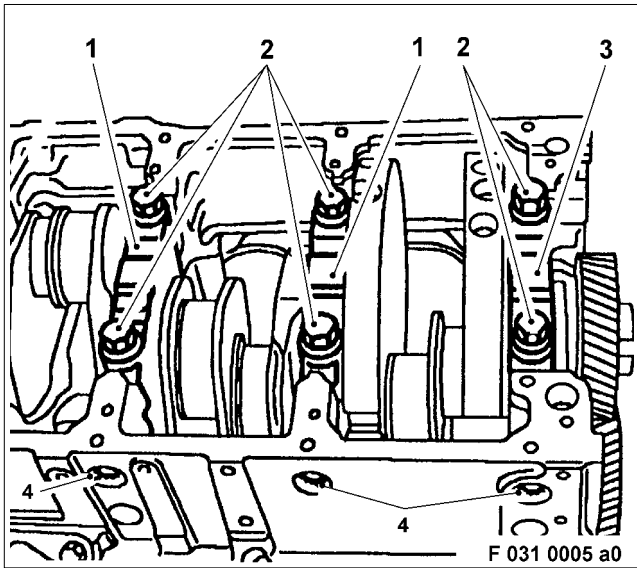

Spray crankshaft bearing journals with engine oil.

Note: Prior to installing bearing cap No. 1, ensure that counterweight is in lower position.

CAUTION

**Components have sharp edges.
Risk of injury.
Touch components only when wearing protective gloves.**

Insert crankshaft alignment bearing cap (3) and crankshaft bearing cap (1) in accordance with marking into crankcase.

Insert centre hex screws (2) into position and tighten hand-tight.

Coat thread and mating face of side double-hex screws (4) with engine oil and insert double-hex screws but do not tighten.

Starting at central screws of alignment bearing, pretighten to specified pretightening torque – see C 031.05.01.

Note: Always tighten screws on one bearing at same time.
Tightening sequence starts from alignment bearing.

Mark screw heads.

Tighten screws through specified angle of further rotation.

Tighten side double-hex screws to specified torque in same sequence as when tightening centre screws – see C 031.05.01.

Note: Tighten screws on one bearing at same time.

Bar crankshaft manually and check for ease of movement.

Crankshaft must turn freely.

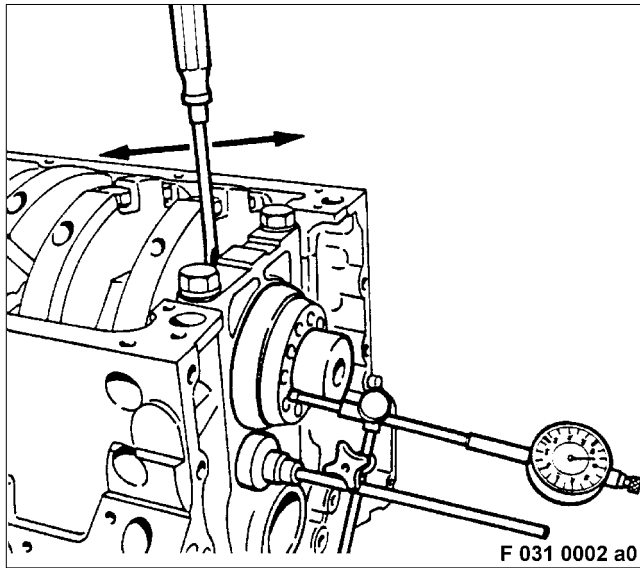

Measuring crankshaft axial play

Mount magnetic dial gauge holder with dial gauge on crankcase.

Position dial gauge stylus against front face of crankshaft.

Using a screwdriver, press crankshaft axially as far as it will go.

Set dial gauge with preload to zero.

Move crankshaft from stop to stop (arrows) and enter measured value (axial clearance) in data sheet.

If determined measured value is outside permissible tolerance – see Tolerance and Wear Limits List, remove crankshaft and check cause.

C 031.05.12 After-Installation Operations

A distinction must be made as to whether:

- 1 — The engine was completely disassembled
- 2 — The engine is removed but was not disassembled
- 3 — The engine is installed

1	2	3	Operations	See
x	-	-	Perform operations as per Assembly Plan	B 005
x	-	-	Install engine	B 007



C 032.05 PTO, Driving End

C 032.05.01 General View

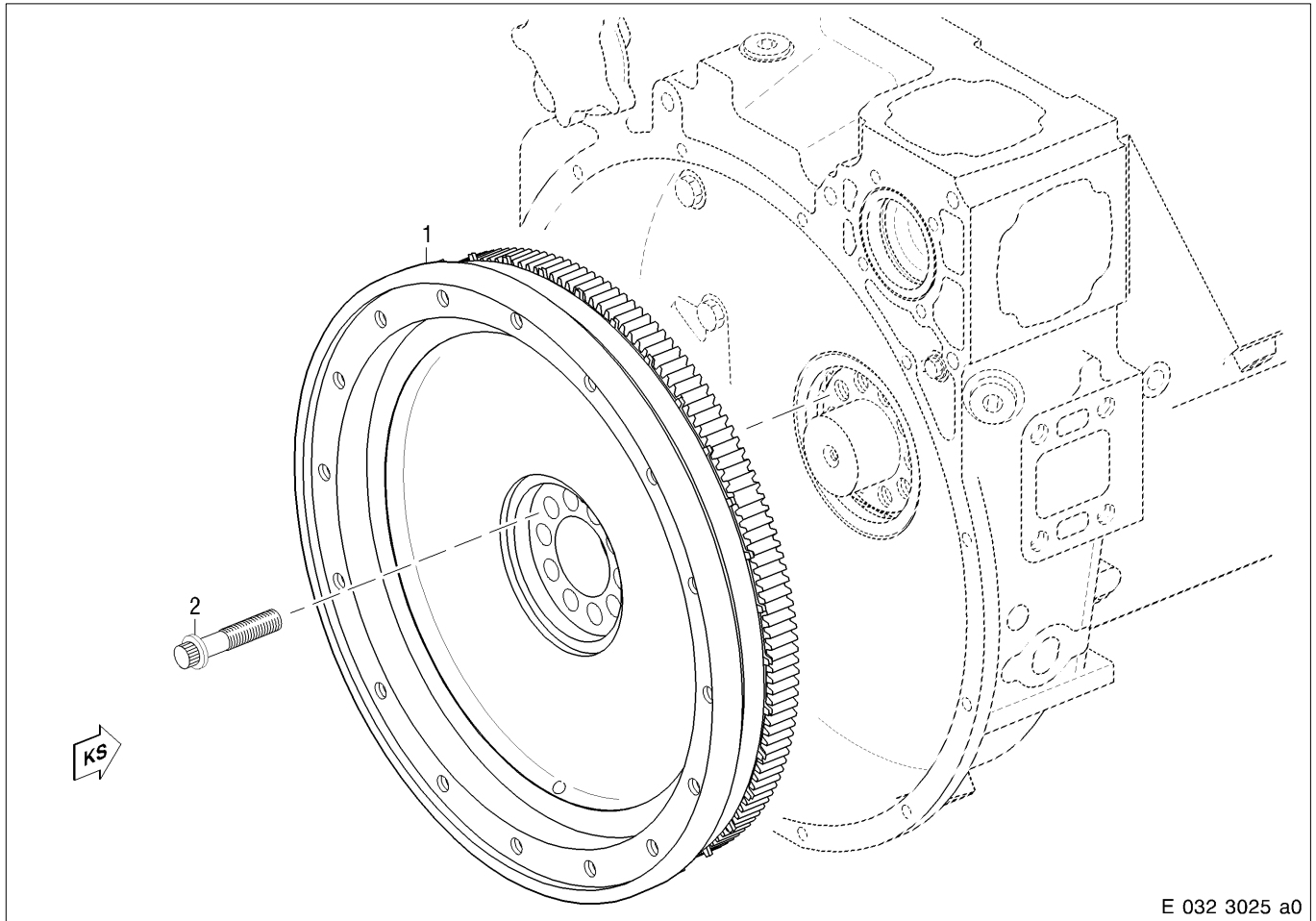

- 1 Flywheel
- 2 Double-hex screw
Max. shaft length: 75 mm
Tightening torque: 260 Nm
Lubricant: Engine oil

Flywheel

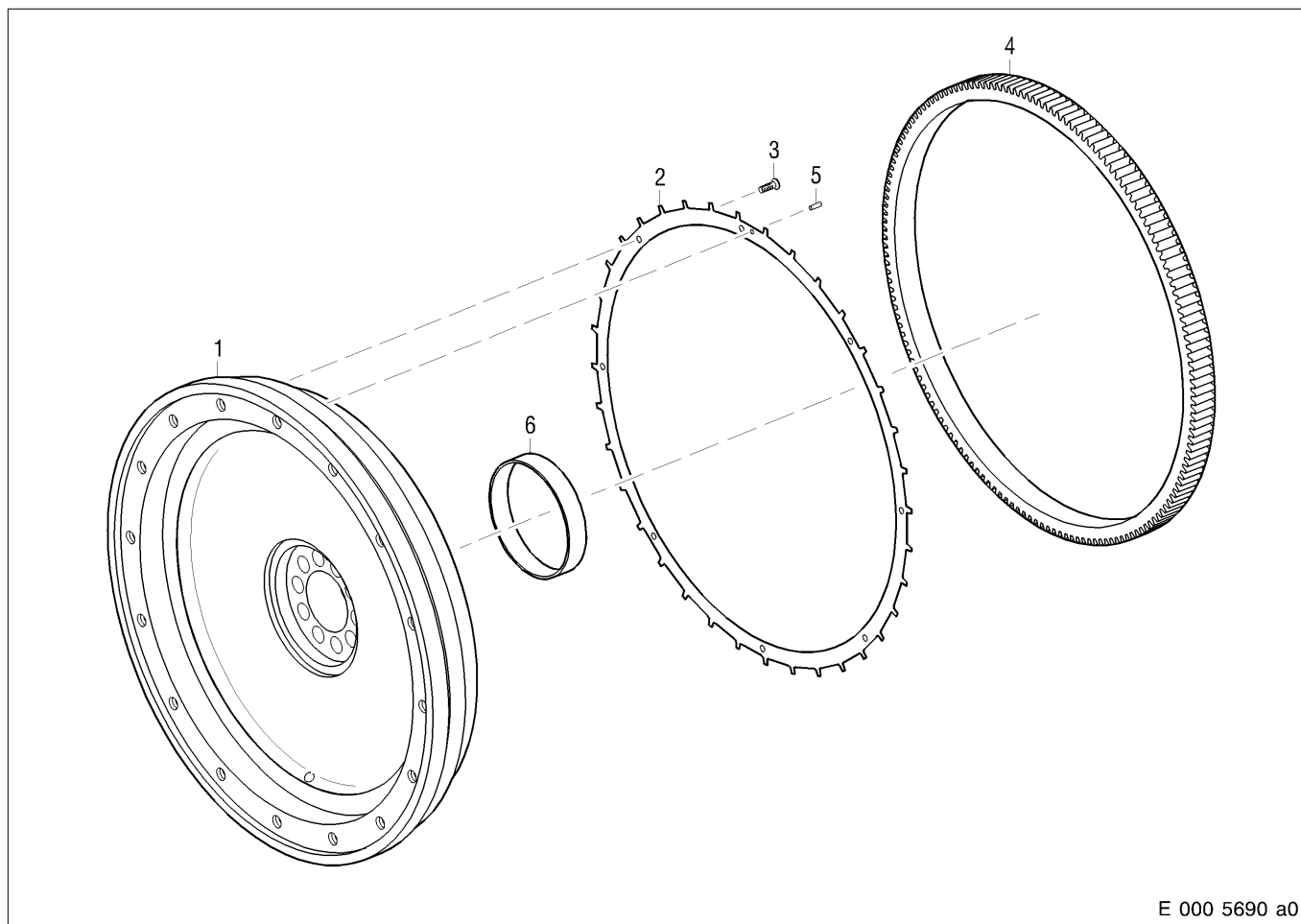

E 000 5690 a0

- 1 Flywheel
- 2 Measuring wheel
- 3 Countersunk screw
- 4 Starter ring
- 5 Dowel pin
- 6 Track ring

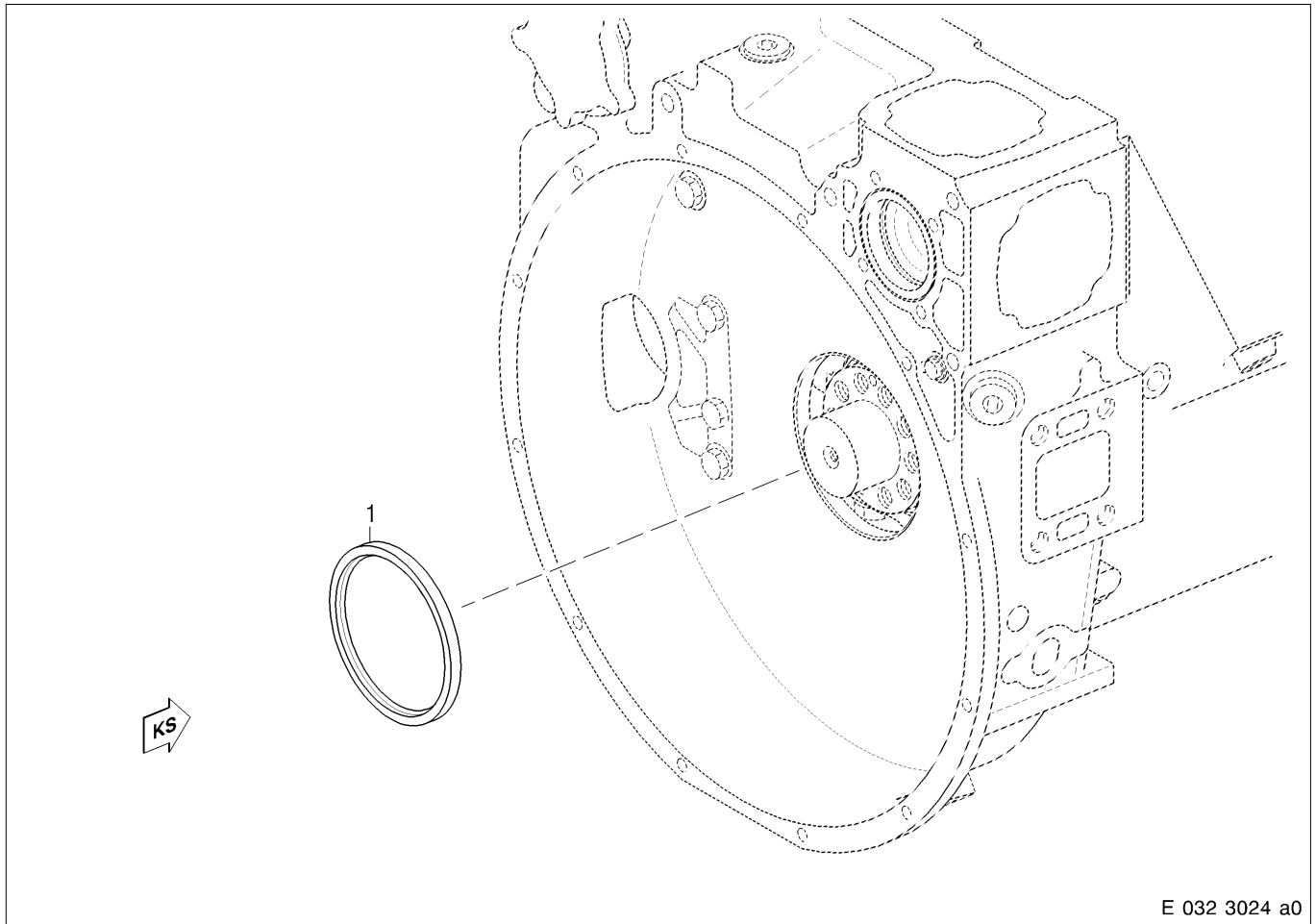

1 Shaft seal

C 032.05.02 Special Tool

Designation – Application	Number
Locking device for flywheel	1
Support pin for flywheel	2
Mandrel for track ring installation	1
Removal tool with thrust pad for track ring	1
Press-in mandrel for shaft seal	1
Spacer sleeve for shaft seal	1

C 032.05.04 Before-Removal Operations

A distinction must be made as to whether:

- 1 — The engine is to be completely disassembled
- 2 — The engine is to be removed but not disassembled
- 3 — The engine is to remain installed

1	2	3	Operations	See
x	-	-	Remove engine	B 003
x	-	-	Perform operations as per Disassembly Plan	B 004
-	-	x	Disable engine start	Operating Instructions
-	x	x	Separate engine from gearbox or alternator	-
-	x	x	Remove coupling	Special Publication

C 032.05.05 Removal

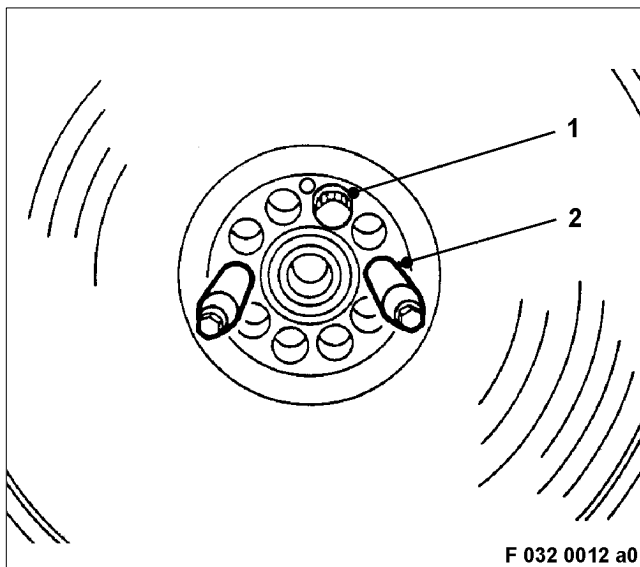

Removing flywheel

Lock engine on flywheel with locking device.
 Remove all double hex screws for flywheel except one (1).
 Insert two support pins (2) into two opposing threaded bores in crankshaft.

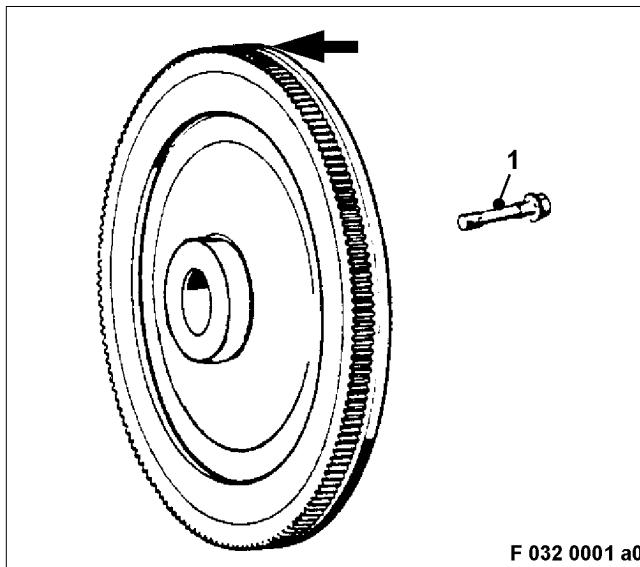

Install eyebolt (arrow) into flywheel.
Attach flywheel to crane and rope and slightly tension ropes.
Remove last double hex screw (1) for flywheel.

! WARNING

**Heavy object.
Risk of injury!
Use suitable tools and lifting equipment.**

Using crane and rope, remove flywheel from flywheel housing via support pin.
Ensure dowel pin fit in crankshaft gear flywheel is correct.

Note: If the flywheel is sitting securely, insert two screws into opposing bores in flywheel and lift off the flywheel.

Remove support pin and locking device.

Removing radial-lip shaft seal from flywheel housing

Using a suitable extracting tool, draw the shaft seal (1) out of the flywheel housing.

Note: Do not damage flywheel housing and crankshaft.

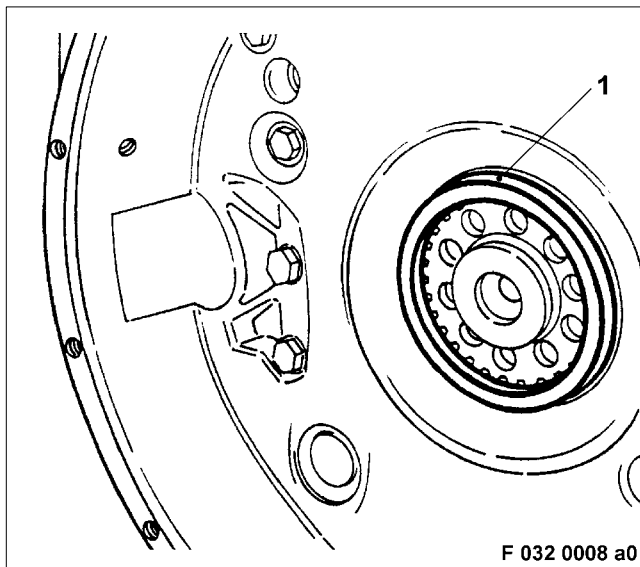

C 032.05.06 Disassembly

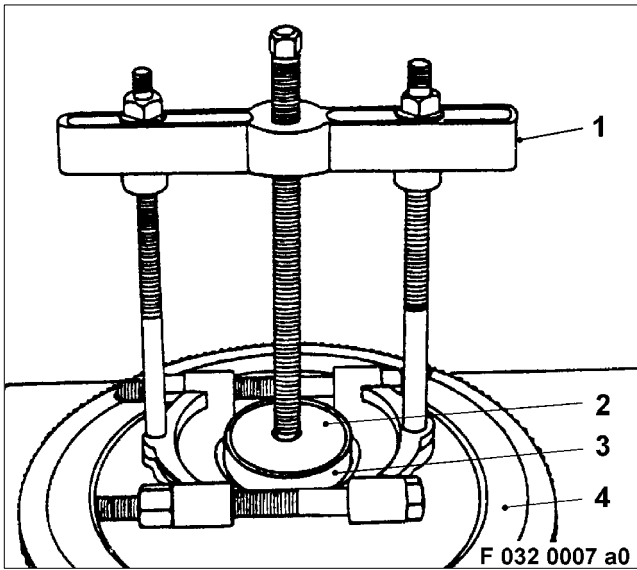

Removing track ring from flywheel

Note: Remove track ring (3) only if necessary (e.g. due to wear).

! WARNING

**Heavy object.
Risk of injury!
Use suitable tools and lifting equipment.**

Lay flywheel (4) on workbench.

Remove track ring with removal tool (1) and thrust pad (2) from flywheel.

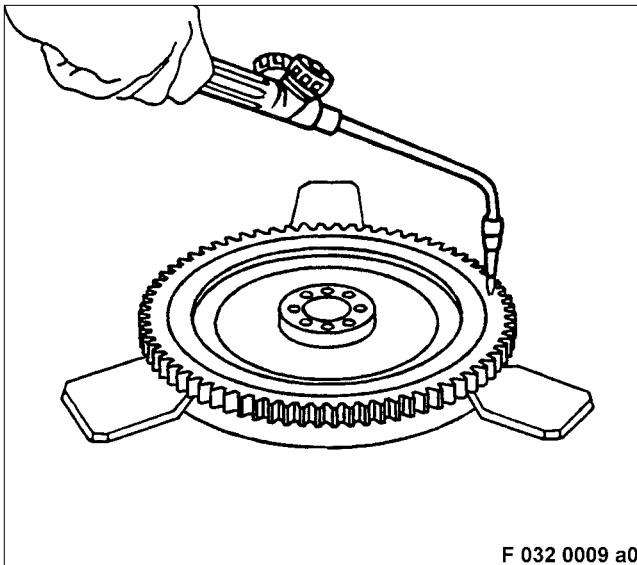

Removing starter ring and measuring wheel from flywheel.

Note: Remove starter ring and measuring wheel only if necessary (e.g. when damaged).

Support starter ring as shown in illustration.

! CAUTION

**Component is hot.
Risk of injury!
Touch components only when wearing protective gloves.**

Using a welding torch, quickly heat the starter ring up to 250 °C to 280 °C and press off flywheel.

Unscrew all countersunk head screws as shown in General View C 032.05.01 and press measuring wheel off flywheel.

If necessary (e.g. due to damage), remove dowel pin from flywheel.

C 032.05.08 Inspection and Repair

Clean all components.

Using the magnetic crack-testing method with fluorescent powder, check flywheel and double hex screws on flywheel for cracks. If cracks are detected, replace part.

Check mating faces on flywheel for evenness, wear, scoring and indentations; recondition if necessary.

Renew flywheel if scoring and indentations are greater than the maximum permissible material removal – see Tolerance and Wear Limits List.

Check track ring for wear; in the event of wear marks, replace track ring.

Check double hex screws on flywheel for perfect condition. Check threads for ease of movement, replace hex screws if necessary.

Measure shaft length of double-hex screws. For maximum permissible shaft length – see C 032.05.01.

If max. shaft length is exceeded, replace screw.

Check condition of dowel pin; replace if necessary.

Check thread in flywheel for perfect condition and ease of movement, rechase if necessary.

Check starter ring and measuring wheel for wear and distortion; replace as necessary.

Remove slight burrs and chipping from starter ring gear teeth by grinding or filing.

Replace shaft seal during W6 overhaul.

C 032.05.10 Assembly

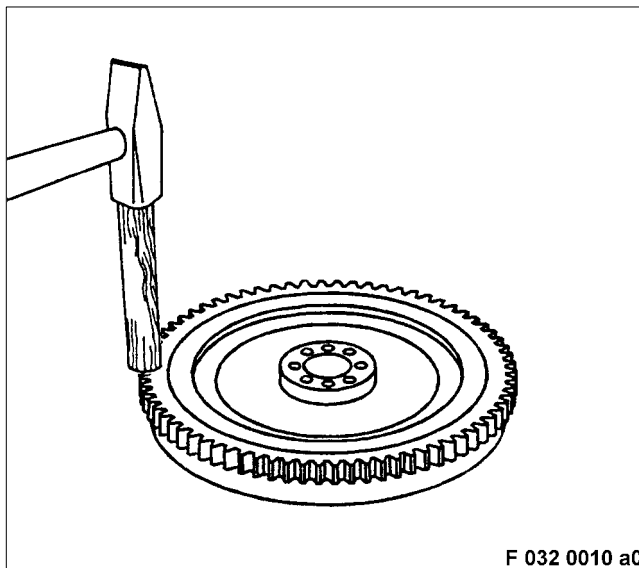

Mounting starter ring and measuring wheel onto flywheel.

WARNING

**Heavy object.
Risk of injury!
Use suitable tools and lifting equipment.**

Lay flywheel on workbench.

Measure flywheel diameter for mounting the starter ring.

Measure starter ring inner diameter

Check projection of starter ring with regard to flywheel, see Tolerance and Wear Limits List.

Mount measuring wheel on the flywheel, as shown in General View C 032.05.01, ensuring that the dowel pin is properly fitted.

Insert countersunk head screw and tighten diagonally and evenly.

Heat new starter ring to approx. 220 °C.



CAUTION

Component is hot. Risk of injury! Touch components only when wearing protective gloves.

Fit starter ring to mating surface on flywheel and secure.

Note: Chamfer on the teeth faces upwards!

Allow starter ring to cool to room temperature and check that it is evenly in position along the entire circumference. The permissible runout of the press-fitted starter ring must not be exceeded, see Tolerances and Wear Limits List.

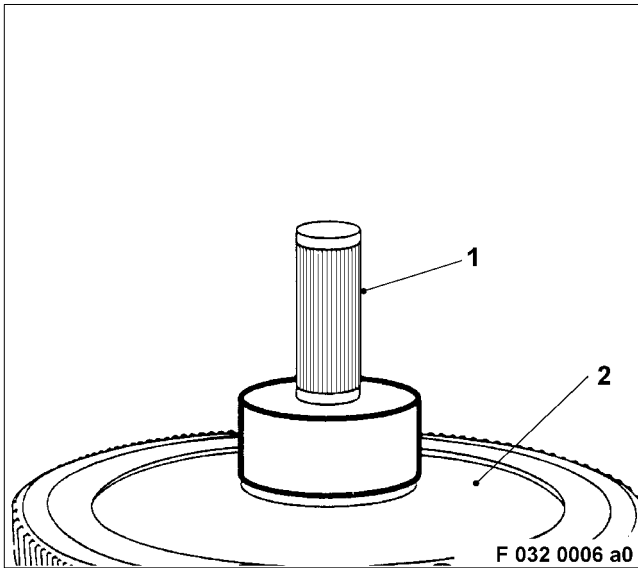

Installing track ring on flywheel

Fit new track ring with rounded edge in direction of mandrel (1) and heat to max. 200°C.

CAUTION

**Component is hot.
Risk of injury!
Touch components only when wearing protective gloves.**

Mount heated starter ring onto flywheel until contact is made.

While the track ring is cooling down, press-fit it onto mating surface.

Allow track ring to cool to room temperature and check that it is evenly in position along the entire circumference.

C 032.05.11 Installation

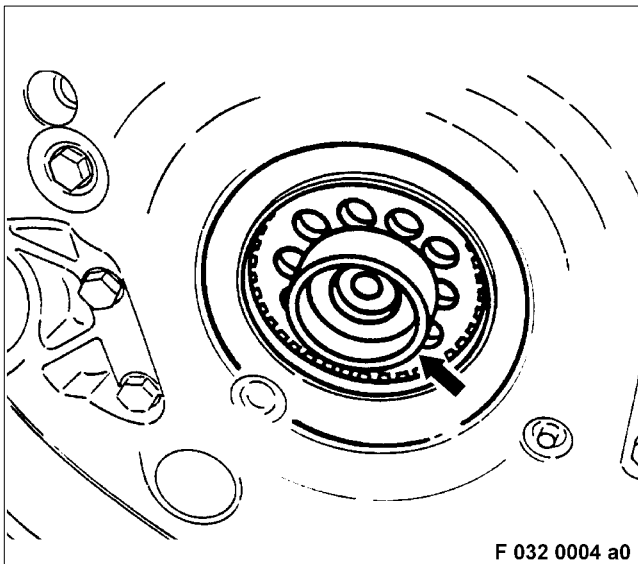

Installing radial-lip shaft seal into flywheel housing

Clean and degrease sealing face for radial-lip oil seal in flywheel housing.

Fit spacer sleeve (arrow) over crankshaft.

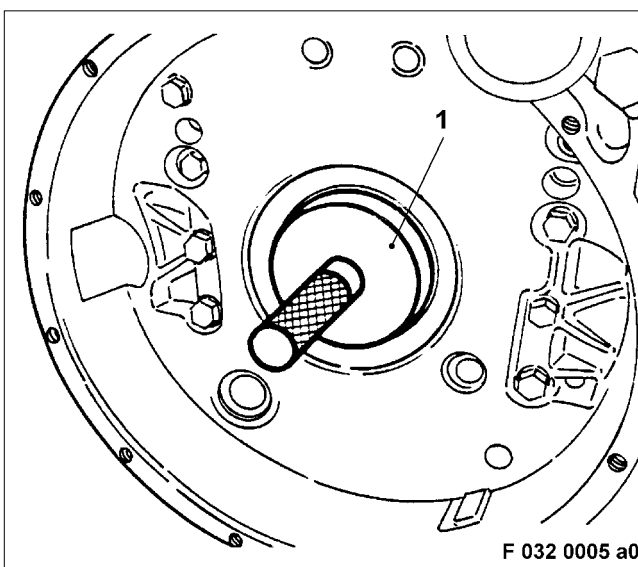

Place the radial-lip shaft seal on the press-in mandrel (1) with the sealing lip facing outwards.

Coat OD sealing face of radial-lip oil seal with denaturated ethanol.

Note: Denaturated ethanol acts as lubricant for press-fitting.

Using a press-in mandrel, press-fit radial-lip into flywheel housing until it sits in position.

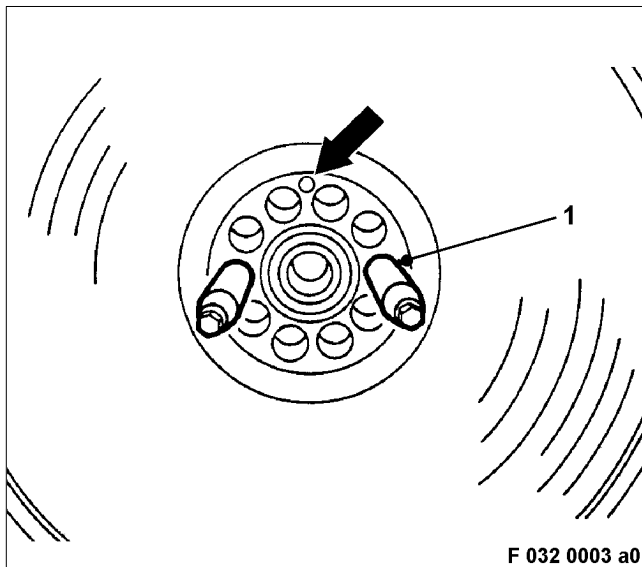

Installing flywheel

Insert two support pins (1) into opposing threaded bores in crankshaft.

Note: The dowel pin (arrow) in crankshaft gear and centering bore in flywheel must be aligned.

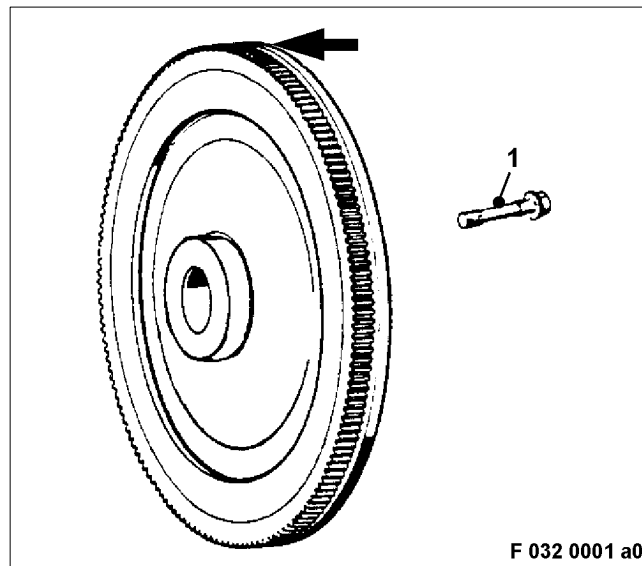

WARNING
Heavy object. Risk of injury! Use suitable tools and lifting equipment.

Install eyebolt into flywheel (arrow).
Attach flywheel with crane and ropes.
Using crane and rope, position flywheel on hub via guide pin.
Ensure dowel pin fit in crankshaft gear is correct.
Measure shaft length of double-hex screws (1) in flywheel. For max. permissible shaft length – see C 032.05.01.
Insert double hex screws (1) and tighten diagonally and evenly.
Remove support pin and lifting device.

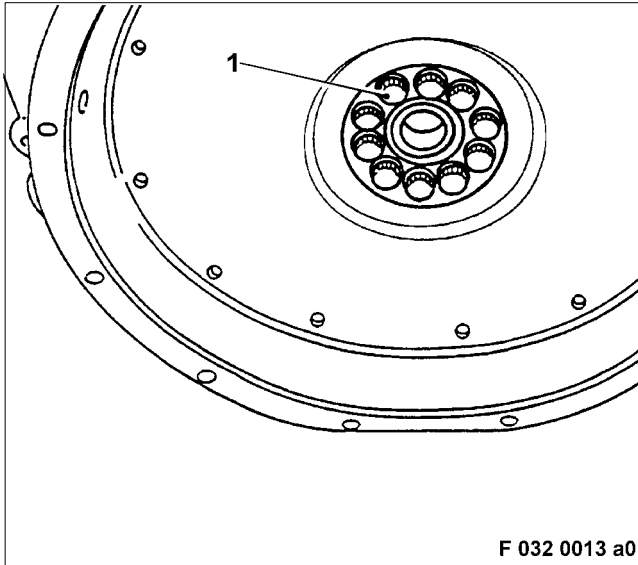

Lock engine on flywheel with locking device.
 Tighten double hex screws (1) diagonally and evenly to specified torque – see C 032.05.01.
 Remove locking device.

C 032.05.12 After-Installation Operations

A distinction must be made as to whether:

- 1 — The engine was completely disassembled
- 2 — The engine is removed but was not disassembled
- 3 — The engine is installed

1	2	3	Operations	See
x	–	–	Perform operations as per Assembly Plan	B 005
x	–	–	Install engine	B 007
–	x	x	Install coupling	Special Publication
–	–	x	Connect engine with gearbox/alternator	–
–	–	x	Release engine start	Operating Instructions

C 035.05 PTO, Free End

C 035.05.01 General View

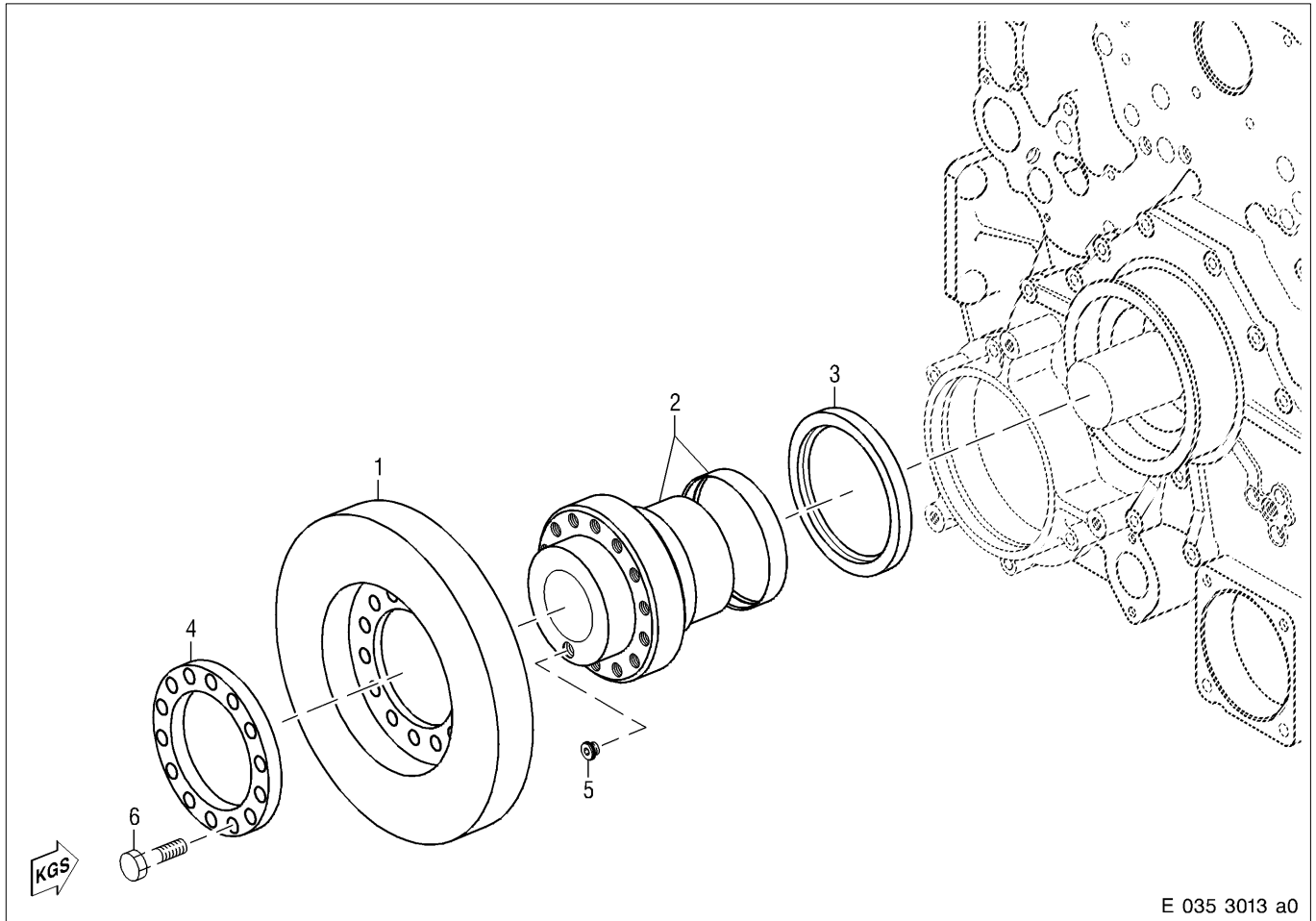

E 035 3013 a0

- 1 Vibration damper
 - 2 Hub and track ring
 - 3 Shaft seal
 - 4 Intermediate ring
 - 5 Plug
 - 6 Hex screw
- Tightening torque: 180 Nm
Lubricant: Engine oil

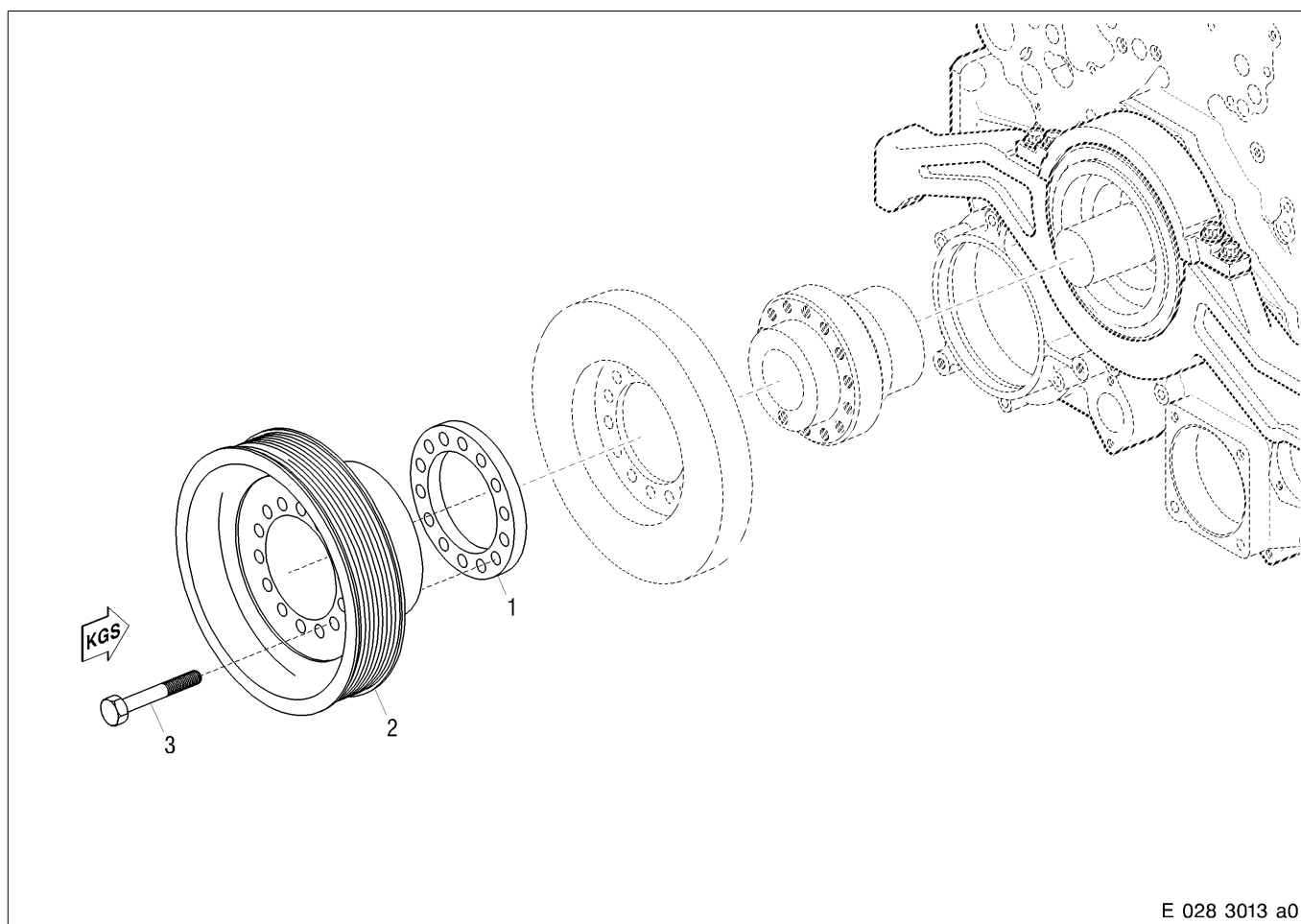

- 1 Spacer ring
 - 2 Belt pulley
 - 3 Hex screw
- Tightening torque: 180 Nm
Lubricant: Engine oil

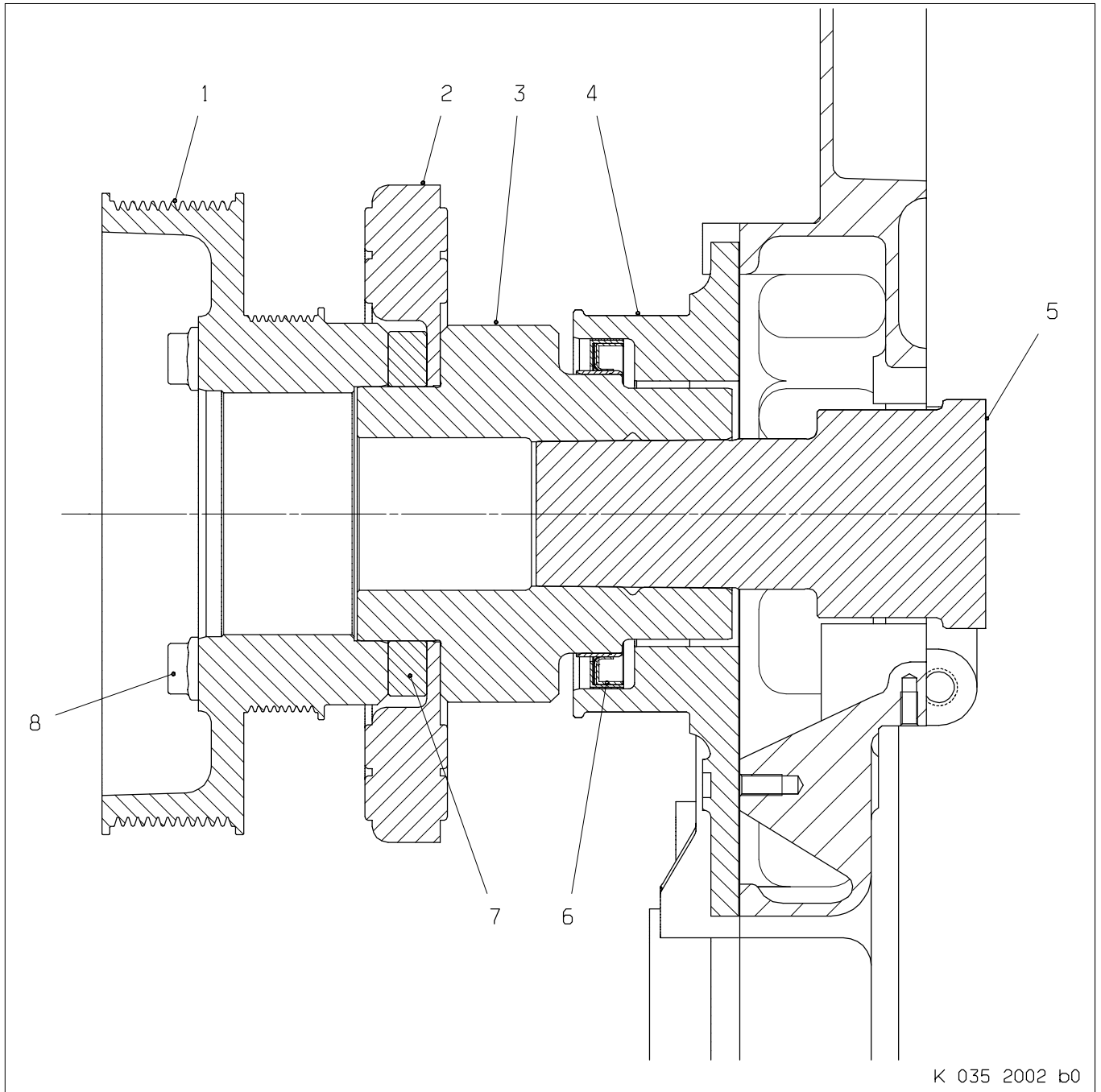

- 1 Belt pulley
- 2 Vibration damper
- 3 Hub
- 4 Gear case cover
- 5 Crankshaft

- 6 Shaft seal
 - 7 Spacer
 - 8 Hex screw
- Tightening torque: 180 Nm
Lubricant: Engine oil

C 035.05.02 Special Tool

Designation – Application	Number
Installation/removal tool for vibration damper	1
Oil pressure hand pump 0–3500 bar	1
Lukas hand pump	1
Locking device for flywheel	1

C 035.05.04 Before-Removal Operations

A distinction must be made as to whether:

- 1 ————— The engine is to be completely disassembled
- 2 ————— The engine is to be removed but not disassembled
- 3 ————— The engine is to remain installed

1	2	3	Operations	See
x	–	–	Remove engine	B 003
x	–	–	Perform operations as per Disassembly Plan	B 004
–	–	x	Disable engine start	Operating Instructions
–	x	x	Remove guard	–
–	x	x	Remove V-belt	C 028.05

C 035.05.05 Removal

Removing vibration damper

Lock engine on flywheel with locking device.

Remove securing screws for vibration damper as shown in General View – see C 035.05.01.

Remove belt pulley, spacer ring and vibration damper and/or intermediate washer and vibration damper from the hub, see C028.05.

Remove locking device.

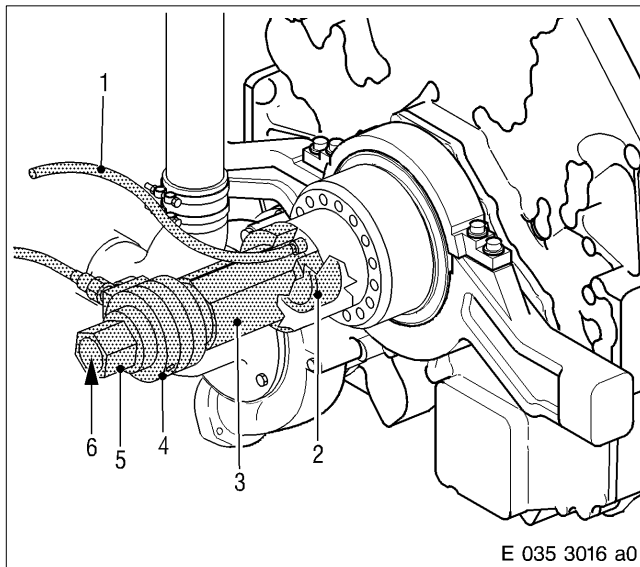

Pressing off hub

⚠ WARNING

Equipment which is faulty, installed incorrectly or not in accordance with specifications may become loose or drop off and cause serious injury.

Risk of knocks or crushing!
Liquids emerging under high-pressure can lead to serious injury!

Hydraulic installation/removal must be carried out only by qualified personnel. Only use specified and tested equipment.

The specified expansion and push-on pressure must not be exceeded.

No-one is permitted to enter the danger zone behind the device while installation/removal is in progress. Do not attempt to bend or exert force on h.p. lines.

Always wear protective gloves and protective goggles/safety mask.

Remove plug from expanding bore in the hub.

Insert draw spindle (6) into crankshaft to the stop and then rotate outwards one revolution.

Mount spacer sleeve (2), pressure bush (3) and hydraulic press (4) over spindle (4) and install nut (5). Insert reducer into hub and connect up H.P. line (1). Connect H.P. line of Lukas hand pump to hydraulic press.

Fit nut up to stop and back off approx. 15 mm.

Note: Before tightening nut, make sure that hydraulic press is in initial position (0 stroke).

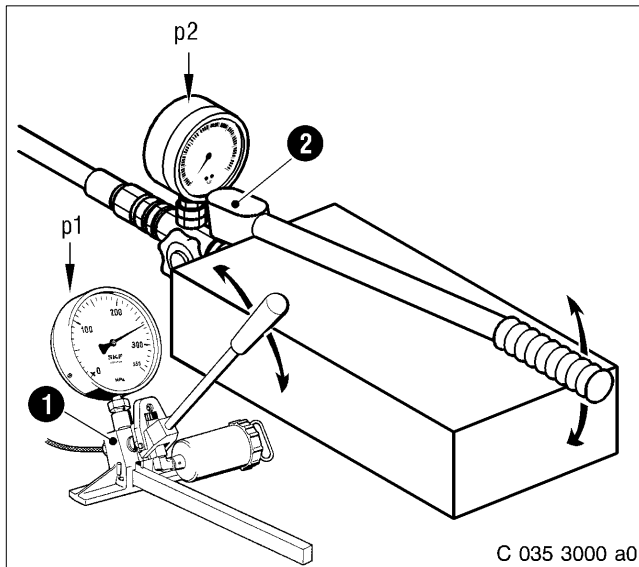

Fill hydraulic hand pumps with SAE 10 engine oil.
Vent pumps and lines until oil escaping is free of bubbles.

Tighten high-pressure line.

Operate Lukas hand pump (2) for hydraulic press and, by applying minimum pressure (p2) (start of pressure increase), seat press against vibration damper.

Note: The hydraulic press acts as a buffer, stopping the hub as it slips off its taper seat.

Operate hydraulic hand pump (1) for expanding hub until expansion pressure is half the maximum permitted (p1).

Maintain this pressure for approx. 5 minutes.

Maximum permitted expansion pressure p_{max} is stamped on hub.

Increase expansion pressure in stages of $0.1 \cdot p_{max}$, waiting approx. 2 minutes between increases, until hub is released from crankshaft.

Do not exceed the maximum permissible expansion pressure p_{max} .

Operate pump to maintain constant expansion pressure.

An increase in pressure (p2) at the hydraulic press indicates that hub is released from crankshaft.

Gradually relieve pressure in hydraulic press while steadily operating pump for expansion fluid.

Relieve pressure in hydraulic hand pumps.

Disconnect high-pressure line.

Remove nut, hydraulic press, pressure bush, spacer sleeve and draw spindle.

Unscrew reducer.

Remove hub from crankshaft.

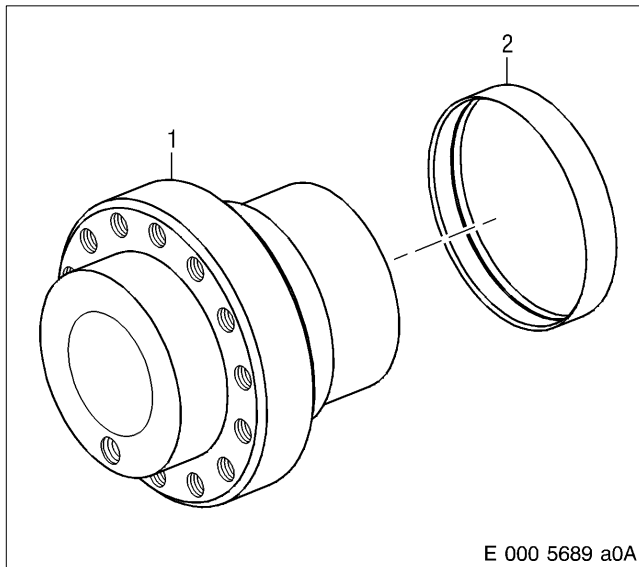

Removing track ring from hub

Note: Remove track ring only if necessary (e.g. due to wear).

Using a suitable remover tool, remove track ring (2) from hub (1).

C 035.05.08 Inspection and Repair

Clean all parts.

Make a visible inspection of all components, especially mating and sliding surfaces for wear and damage.

Remove minor wear and scoring by rubbing down with oilstone or emery cloth.

If there is excess wear or damage, replace component.

Check vibration damper for leakages or fluid loss.

Replace the vibration damper if it is found to be leaking.

Check threads in hub for ease of movement; rechase threads if necessary.

Check taper bore of hub with taper plug gauge 1 : 50.

Replace hub if taper bore is oversized.

Check thread of hex screws for ease of movement; replace hex screw as necessary.

Check shaft seal running surface on track ring; replace track ring if the running surface is worn.

Replace vibration damper at W6 overhaul or in the event of overspeed or crankshaft fracture.

C 035.05.11 Installation

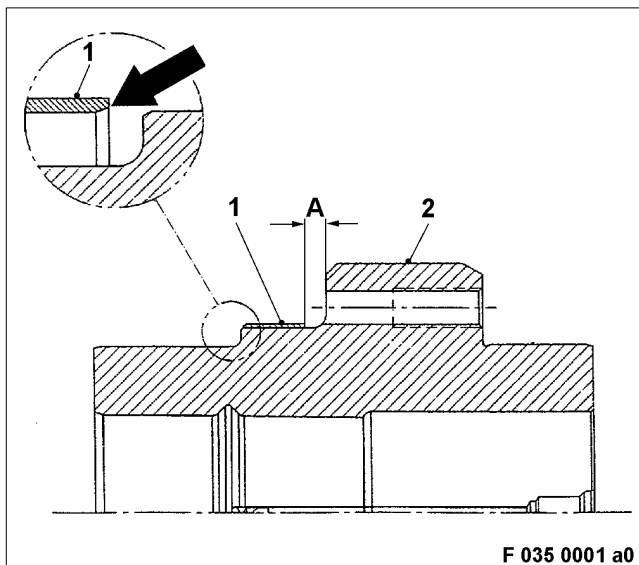

Installing track ring on hub

Heat track ring (1) to approx. 130 °C.

CAUTION

**Component is hot.
Risk of injury!
Handle components only when wearing protective gloves.**

Push the heated track ring flush onto the hub with the chamfer (arrow) facing the hub (2).

Allow track ring to cool to room temperature and check that the distance (A) is even along the entire circumference.

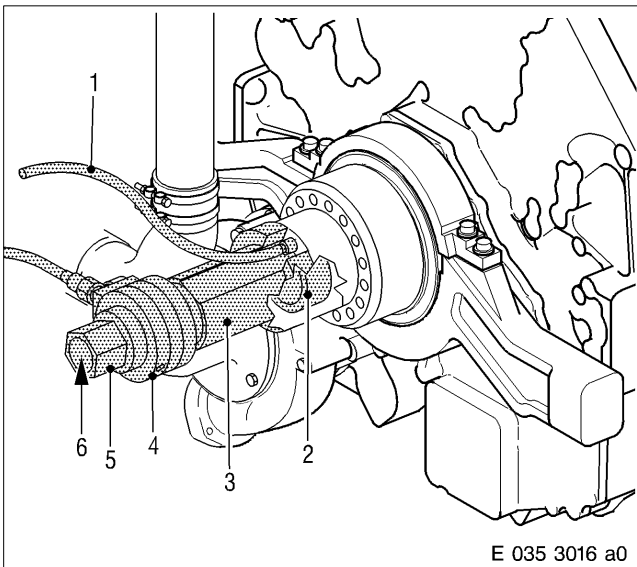

Press-fitting hub (12V)

⚠ WARNING

Equipment which is faulty, installed incorrectly or not in accordance with specifications may become loose or drop off and cause serious injury.

Risk of knocks or crushing!
Liquids emerging under high-pressure can lead to serious injury!

Hydraulic installation/removal must be carried out only by qualified personnel. Only use specified and tested equipment.

The specified expansion and push-on pressure must not be exceeded.

No-one is permitted to enter the danger zone behind the device while installation/removal is in progress. Do not attempt to bend or exert force on high-pressure hoses while they are under pressure.

Always wear protective gloves and protective goggles/safety mask.

Clean and degrease tapers of crankshaft and hub.
Coat running surface of crankshaft bearing and hub with oil.

Coat shaft seal lip with petroleum jelly.

Push hub onto crankshaft taper.

Insert draw spindle (6) into crankshaft to the stop and then rotate outwards one revolution.

Mount spacer sleeve (2), pressure bush (3) and hydraulic press (4) over spindle.

Install nut (5) and hand-tighten.

Note: Before tightening nut, make sure that hydraulic press is in initial position (0 stroke).

Insert reducer into hub and H.P. line (1).

Connect H.P. line of Lukas hand pump to hydraulic press.

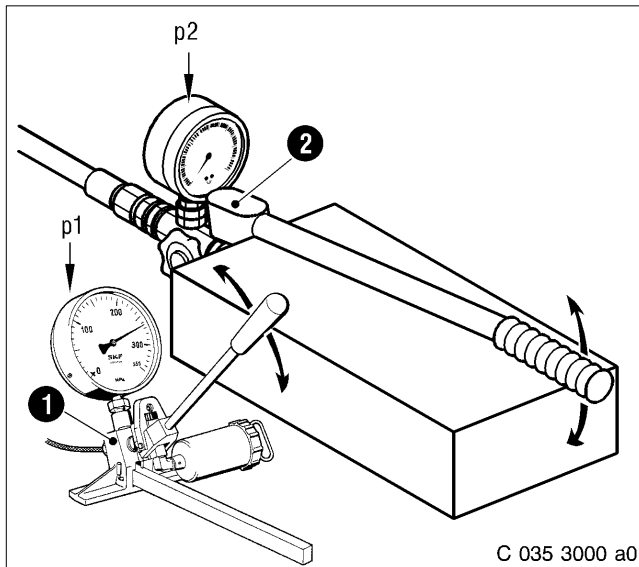

Fill oil pressure hand pumps with engine oil SAE 10.
Vent pumps and lines until oil escaping is free of bubbles.

Tighten high-pressure line.

Before press fitting, coat taper faces with expansion fluid by operating hydraulic hand pump (1) until expansion fluid emerges at both sides of hub.

Operate Lukas hand pump (2) for hydraulic press and, by applying minimum pressure, position against hub.

Operate pump for expansion fluid until no further increase in expansion pressure (p_1) is possible, then operate force-on pump to increase force-on pressure (p_2).

Repeat this process until the hub is correctly seated.

Select force-on pressure such as to seat shaft in approx. 5 steps.

When installing, make sure that expansion pressure never exceeds the maximum permissible expansion pressure P_{max} .

p_{max} is stamped on hub.

Hydraulic installation is completed when spacer sleeve is seated against crankshaft.

Open valve screw in hydraulic oil pump to relieve expansion pressure.

Maintain maximum force-on pressure for 60 minutes, to ensure that the expansion fluid is expelled from the joint and static friction can build up between the fixed components.

Note: The maximum push-on pressure is the pressure that was required to slide the floating hub onto the shaft.
When using expansion oil of viscosity class higher than SAE 10, a longer retention time is necessary (for SAE 30: retention time 2.5 hours)

Disconnect high-pressure line.

After specified retention time has elapsed, remove nut, hydraulic press, pressure sleeve, spacer sleeve and draw spindle.

Remove oil from the expansion bore in the hub, insert plug and tighten.

Note: Do not subject press fitting to operating load for at least 8 hours.

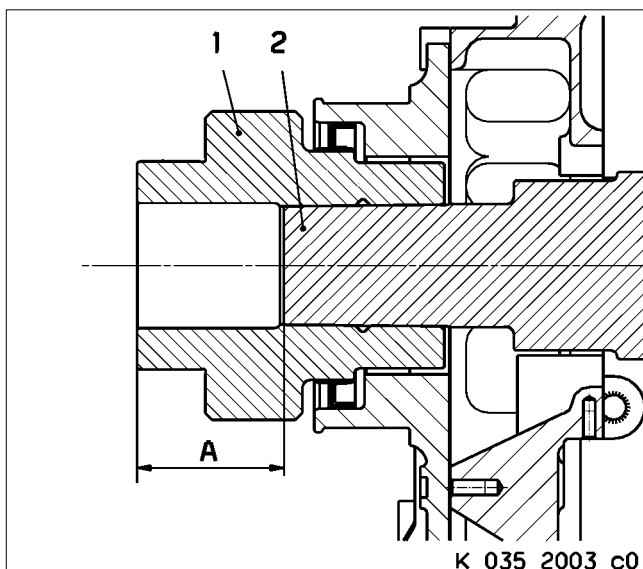

Check distance (A) from end face of crankshaft (2) to end face of hub (1).

Note: Observe the recess in the crankshaft end face. Carry out measurements only at outer edge of crankshaft end face.

Specified distance $A = 84.3 \text{ mm to } 84.7 \text{ mm}$

If specified distance is not achieved, remove hub and determine cause.

Install vibration damper

Lock engine on flywheel with locking device.

Clean all mating faces.

Insert two suitable guide pins into opposing threaded bores in hub.

Install vibration damper, spacer ring and belt pulley on hub (see C 028.05) or install vibration damper and intermediate washer over the guide pins on the hub as shown in General View C 035.05.01.

Note: Ensure that vibration damper is positioned correctly in accordance with General View.

Remove guide pins.

Insert securing screws for vibration damper and tighten diagonally and evenly to specified tightening torque, see C 035.05.01.

Remove locking device.

C 035.05.12 After-Installation Operations

A distinction must be made as to whether:

- 1 ————— The engine was completely disassembled
- 2 ————— The engine is removed but was not disassembled
- 3 ————— The engine is installed

1	2	3	Operations	See
x	–	–	Perform operations as per Assembly Plan	B 005
x	–	–	Install engine	B 007
–	x	x	Install V-belt and setting V-belt tension	C 028.05
–	x	x	Mount protective guard	–
–	–	x	Release engine start	Operating Instructions

C 037.05 Pistons and Conrods

C 037.05.01 General View

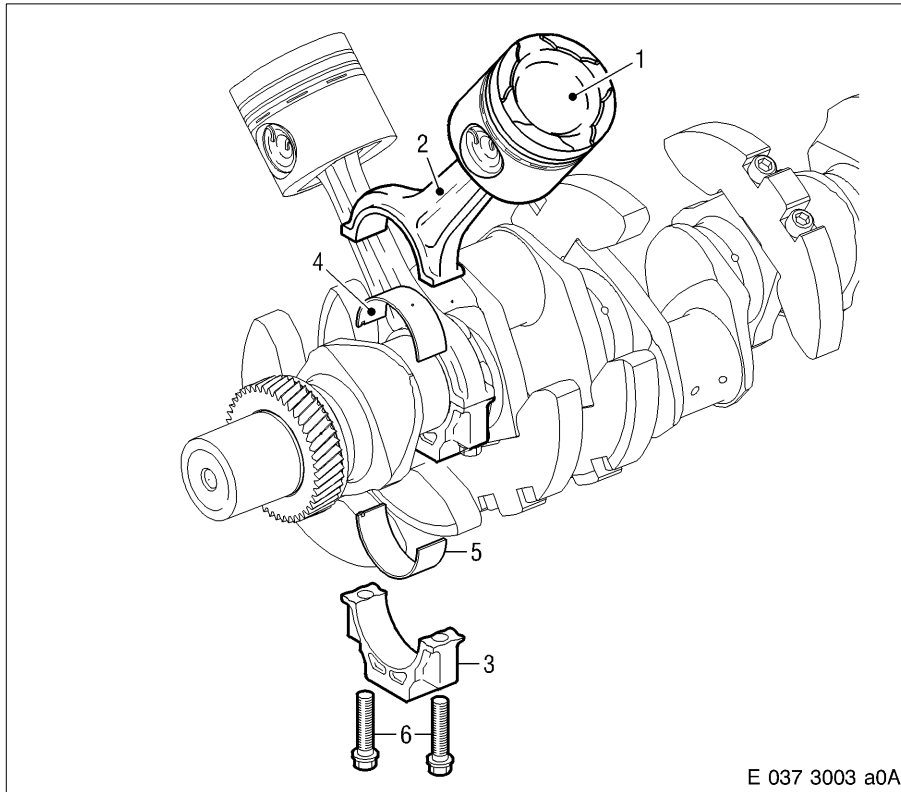

- 1 Piston
- 2 Conrod
- 3 Conrod cap
- 4 Conrod bearing, top
- 5 Conrod bearing, bottom
- 6 Conrod bolt*
 - Max. shaft length: 74.5 mm
 - Pretightening torque: 100 Nm + 10 Nm
 - Angle of further rotation: 90° + 10°
 - Lubricant: Engine oil

*** Replace conrod bolts on a "cracked conrod" every time the engine is disassembled**

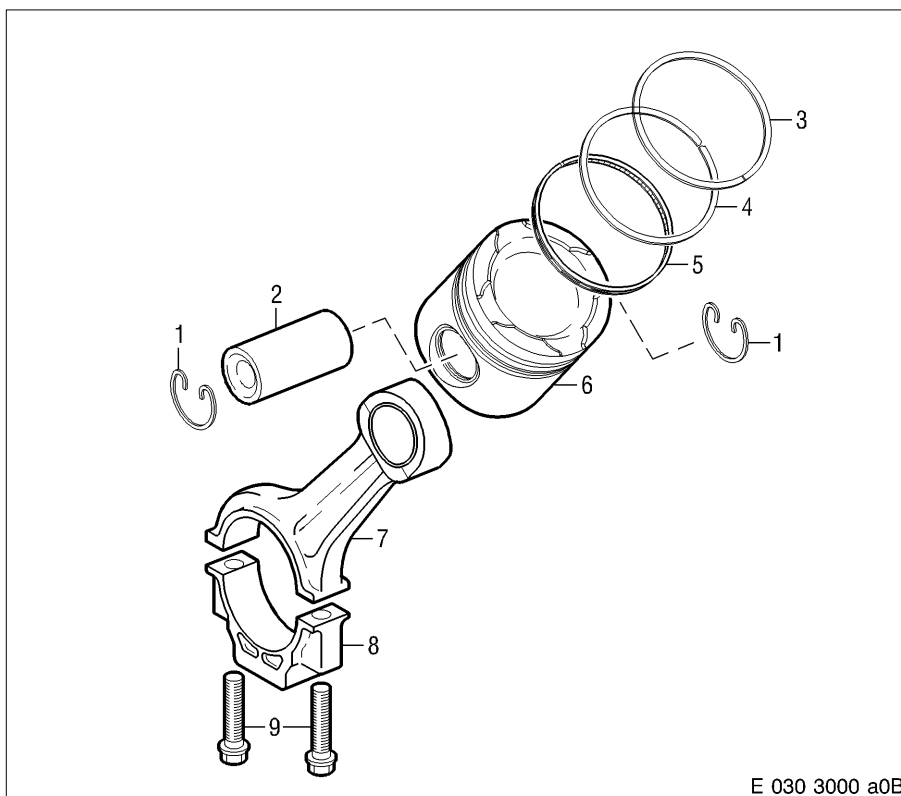

- 1 Snap ring
- 2 Piston pin
- 3 Keystone-type compression ring
- 4 Taper-face compression ring
- 5 Oil scraper ring
- 6 Piston
- 7 Conrod
- 8 Conrod cap
- 9 Conrod bolt*

*** Never screw conrod bearing cap tight without conrod bearing shells.**

C 037.05.02 Special Tool

Designation – Application	Number
Socket for conrod bolts	1
Piston ring pliers	1
Barring tool for flywheel	1
Piston ring band clamp	1
Ring gauge for piston ring end clearance measuring	1
Bridge meter for piston protrusion measuring	1

C 037.05.04 Before-Removal Operations

A distinction must be made as to whether:

- 1 ————— The engine is to be completely disassembled
- 2 ————— The engine is to be removed but not disassembled
- 3 ————— The engine is to remain installed

1	2	3	Operations	See
x	–	–	Remove engine	B 003
x	–	–	Perform operations as per Disassembly Plan	B 004
–	–	x	Disable engine start	Operating Instructions
–	–	x	Drain engine coolant	Operating Instructions
–	–	x	Drain or draw off engine oil	Operating Instructions
–	x	x	Remove air supply system before turbocharger (if necessary)	–
–	x	x	Remove crankcase ventilation (if necessary)	C 018.10
–	x	x	Disconnect or remove electrical cable (if necessary)	–
–	x	x	Release or remove charge air manifold	C 124.05
–	x	x	Remove exhaust turbocharger	C 101.01
–	x	x	Remove exhaust manifold	C 142.05
–	x	x	Remove cylinder head cover	C 055.10
–	x	x	Remove H.P. fuel line	C 073.05
–	x	x	Disconnect leak-off fuel lines	C 086.05
–	x	x	Remove rocker arm assembly	C 055.05
–	x	x	Remove pushrods	C 054.05
–	x	x	Remove cylinder head	C 041.05
–	x	x	Remove oil pan	C 014.05

C 037.05.05 Removal

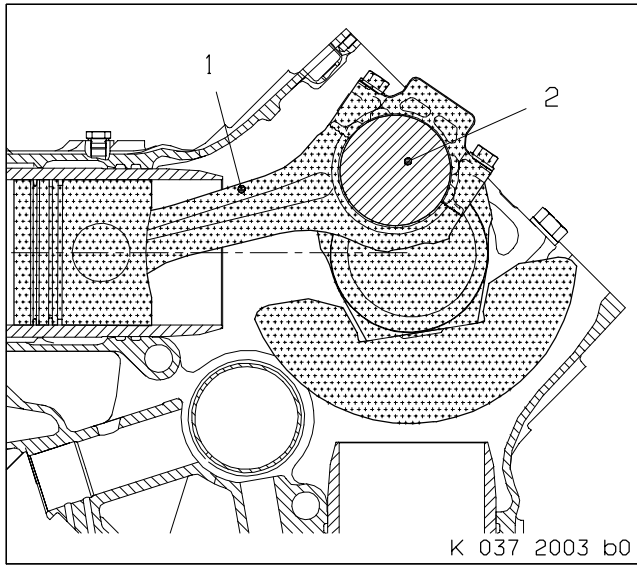

Removing piston with conrod in assembly dolly
Rotate crankcase in assembly dolly until piston to be removed is horizontal.

Turn crankpin (2) of crankshaft of piston and connecting rod (1) to be removed according to sketch in disassembly position.

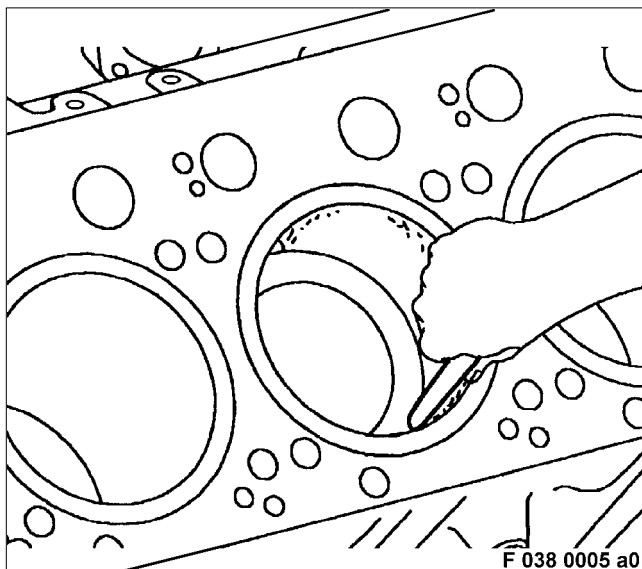

Carefully remove combustion residues over top lands in cylinder liner with a scraper. Take care not to damage running surface!

Note: This ensures that the piston rings are not damaged when the piston is being removed.

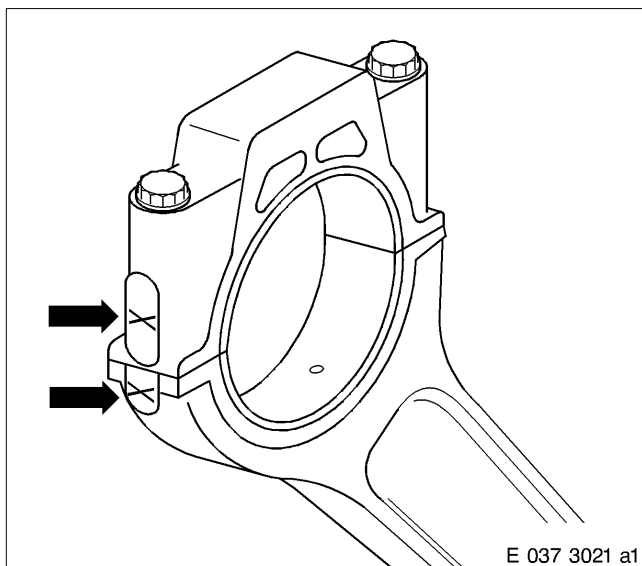

Check marking (arrows) of conrod cap to conrod.
Mark parts as necessary.

Note: Bearing cap and conrod are a single unit and must not be interchanged.

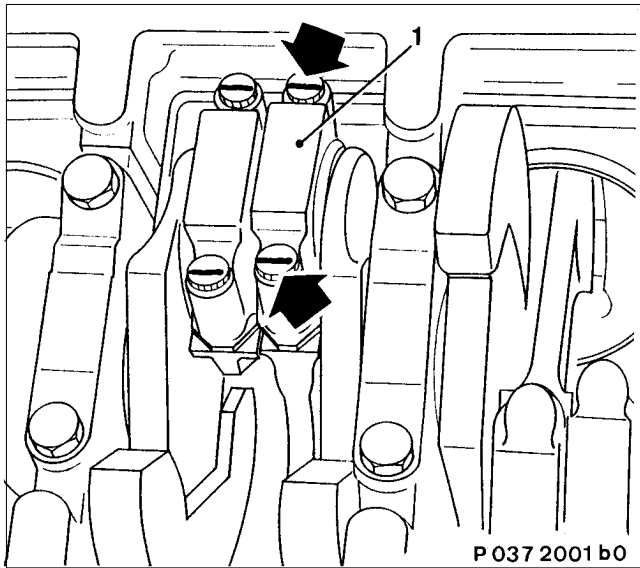

Remove conrod bolts (arrows) with socket and ratchet and remove conrod cap (1).

Remove bearing shell from conrod cap and protect from damage.

Note: Replace conrod bolts on a "cracked conrod" every time the engine is disassembled. The cracked (broken) interfaces must not be damaged; replace conrod as necessary.

Check markings from bearing shell to conrod; reapply markings if necessary.

Note: When removing piston, do not damage or bend oil spray nozzle.

Press piston out of cylinder liner using a wedge of wood at edge of piston skirt.

Remove bearing shell from conrod and protect from damage.

C 037.05.06 Disassembly

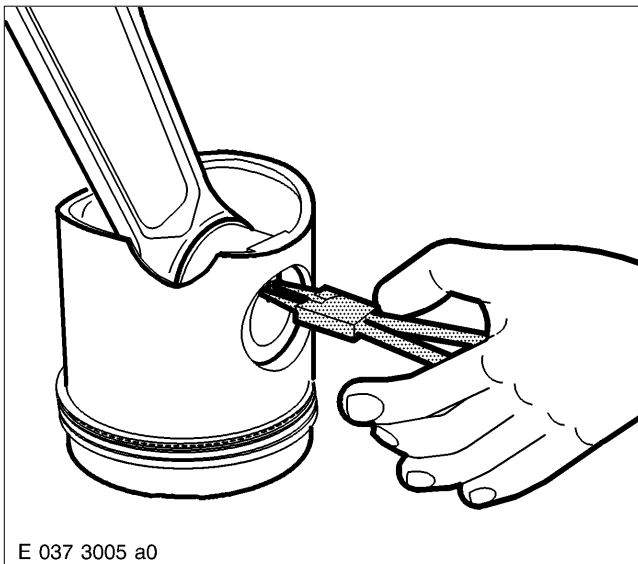

Removing conrod from piston

Place piston and conrod on workbench.

Check marking on conrod, piston and piston pin; correct markings if necessary.

CAUTION

**Snap ring pretension
Risk of injury.
Use suitable circlip pliers. Always wear protective goggles/safety mask.**

Using circlip pliers (1), remove circlips.

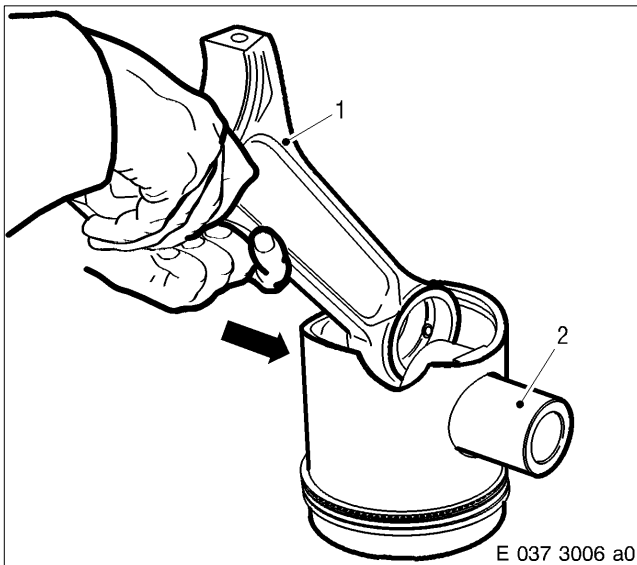

Use wooden rod to press out piston pin (2) (arrow).

Note: Do not use sharp-edged tool to force out piston pin.

Hold conrod (1) and remove piston pin.

Remove conrod from piston.

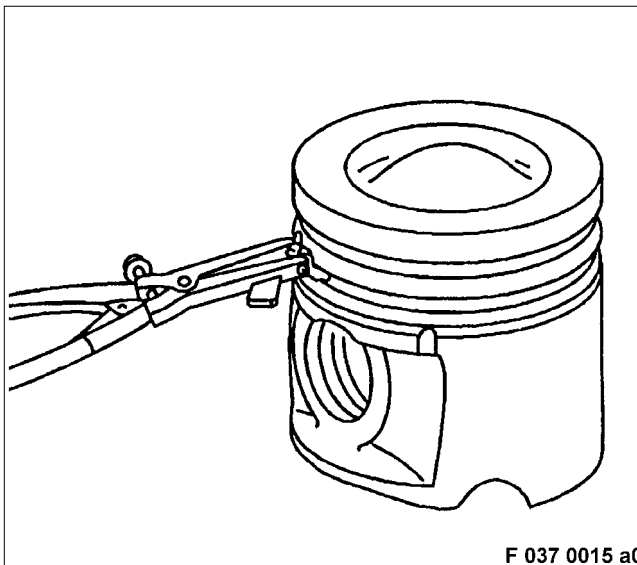

Removing piston rings

Remove piston rings with piston ring pliers in sequence from top to bottom.

Note: Stretch piston rings only until they can be removed from the piston. Do not overstretch piston rings, as they may break.

C 037.05.08 Inspection and Repair

Piston

Note: The graphite layer on the piston skirt must not be mechanically removed or treated with strong cleaners!



CAUTION

When using chemical substances, it is essential to observe the manufacturer's instructions for use, safety instructions and waste disposal specifications.

Treat carbon deposits on piston crown and piston ring grooves with decarbonizer.

Remove remaining residues from piston crown and piston ring grooves by brushing.

Note: Use only a soft brush (e.g. perlon brush) to avoid damaging piston surface.



CAUTION

Compressed air is highly pressurized. Risk of injury!

If compressed air is used for blowing out or blow-drying components, always wear protective goggles or safety mask. Pressure must not exceed 3.0 bar.

After cleaning, blow out oil chamber and oil bores with compressed air and check for particular cleanness.

Using the surface crack-testing method with fluorescent penetrant dye, check piston for cracks; replace if necessary.

Carefully inspect piston ring grooves for cracks.

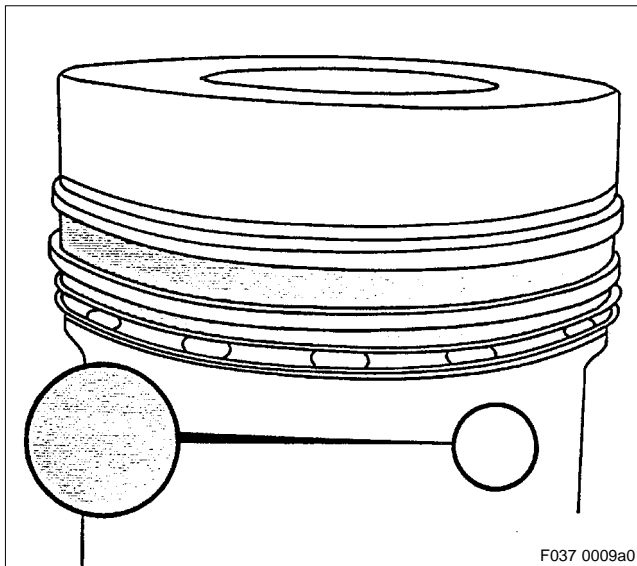

Checking piston skirt and top land

Check piston skirt surface condition for wear, pitting and scoring.

The piston skirt wear pattern must cover most of the surface as the friction scores must be easily identifiable in this area.

Note: The friction scores on the circumference are artificial depressions which are filled with oil and result in improved lubrication.

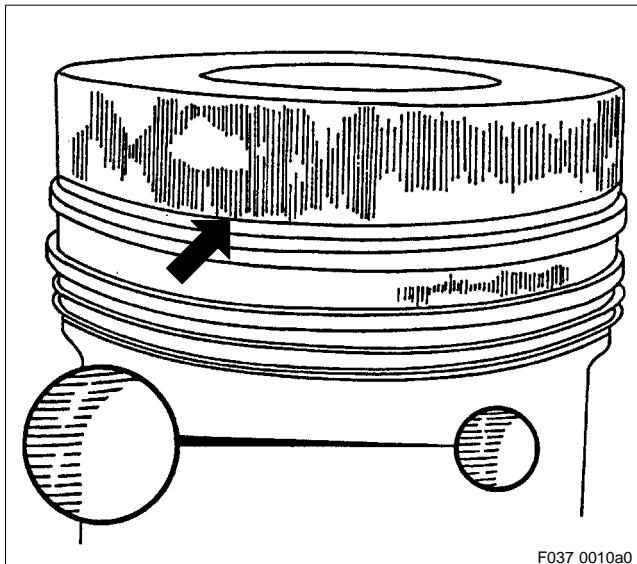

In the event of contact erosion on the piston edge, replace the complete piston.

Remove scoring or scuffing on top land of piston if local and not extending as far as first annular groove.

Replace piston if damage is more extensive, i.e. if scoring or pitting extends as far as the first annular groove (arrow).

In the event of extensive polishing wear on piston skirt (appears dull rather than shiny) and concentrated scoring, replace piston.

Replace pistons exhibiting even minor, localized scuffing on piston skirt.

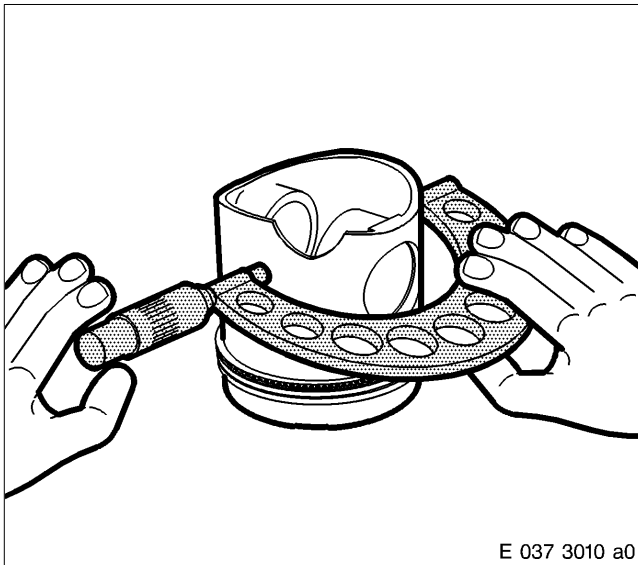

Measuring piston skirt diameter

Use an outside micrometer to measure outside diameter on points free from graphite.

If measurements are below limit values as per Tolerance and Wear Limits List, replace piston.

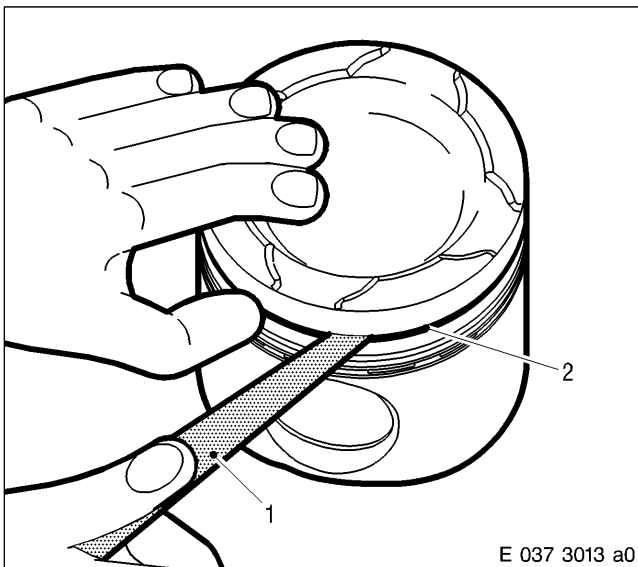

Inspecting piston ring grooves

Check groove width with final measurements.

Alternatively, a new piston ring (2) can be inserted into groove and axial clearance measured with feeler gauge (1).

If the limit values as per Tolerances and Wear Limits List are exceeded, or measurements are below limit values for groove for oil control ring, replace piston.

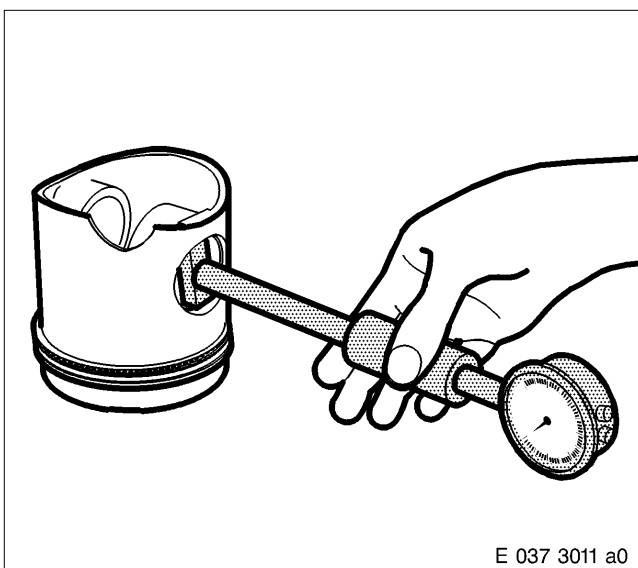

Inspecting piston pin boss

Adjust bore gauge and measure piston pin bore.

If limit values as per Tolerance and Wear Limits List are exceeded, replace pistons.

Check sliding surfaces of bronze bushing for wear and scoring; replace piston as necessary.

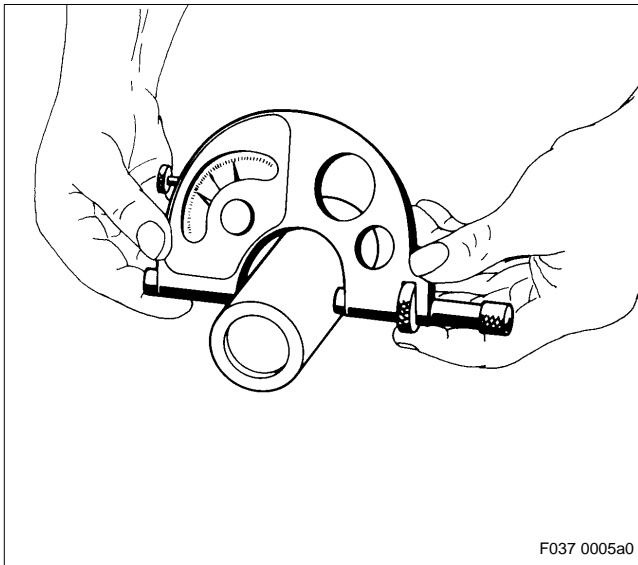

F037 0005a0

Inspecting piston pin

Using magnetic crack-testing method and fluorescent magnetic powder, check piston pin for cracks; if cracks are detected, replace piston pin.

Remove minor traces of wear and scoring by polishing.

Replace piston pins exhibiting scuffing, indentations and severe wear.

Measure outside diameter with outside micrometer and determine pin clearance – see Tolerances and Wear Limits List.

If limit value is exceeded, replace piston pin.

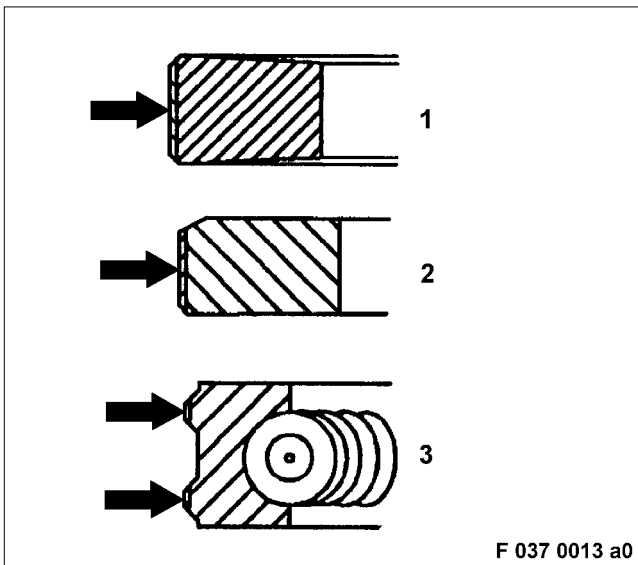

F 037 0013 a0

Inspecting piston rings

Replace piston rings during W6 overhaul.

Clean piston rings of combustion residue and check for damage; replace if necessary.

Condition or wear of chrome layer (arrow) is a deciding factor when reusing or replacing keystone-type compression ring (1), taper face compression ring (2) and oil scraper ring (3).

Chrome layer must not show signs of scoring, cracks or heat discoloration.

Replace sharp-edged piston rings.

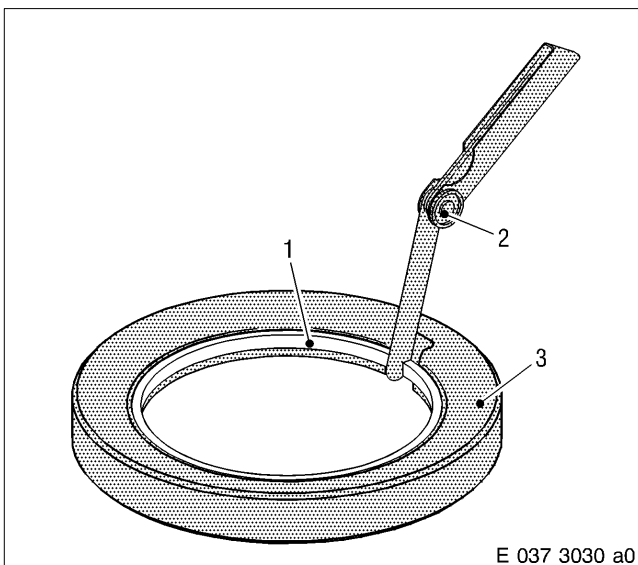

E 037 3030 a0

Place piston ring (1) in ring gauge (3) to measure piston ring end clearance.

Ensure that piston ring is fitted evenly in ring gauge!

Check piston ring gap with feeler gauge (2).

If limit values as per Tolerances and Wear Limits List are exceeded, replace piston rings.

Note: Piston rings must only be replaced in sets. Hone cylinder liners if new piston rings are installed.

Connecting rod

Note: Replace conrod bolts on a "cracked conrod" every time the engine is disassembled.

Using magnetic crack-testing method with fluorescent magnetic powder, check conrod, conrod cap and conrod bolts for cracks.

Replace cracked components.

Check conrod and conrod bolt threads for ease-of-movement.

Polish out all traces of nicks in conrod; replace conrod if necessary.

Check conrod for blue colouring; if blue colouring is detected (due to bearing damage), replace connecting rod.

Check main bore for wear and scoring; if necessary machine bore to repair size or replace conrod.

Check conrod bush for scoring, dirt, wear and hot runs; burnish minor scoring with emery cloth; replace conrod bush if necessary.

Smooth conrod main bore with emery cloth.



CAUTION

Compressed air is air which has been compressed under pressure. If compressed air is used for blowing out or blow-drying components, always wear protective goggles or safety mask. Compressed air must not be directed at the body.

Clean interfaces of conrod and conrod cap and blow dry with compressed air.

The cracked (broken) interfaces must not be damaged; replace connecting rod as necessary.

Check that lube oil bore in connecting rod is perfectly clean; if necessary clean with bristle brush and blow with compressed air.

Note: Never use a wire brush!

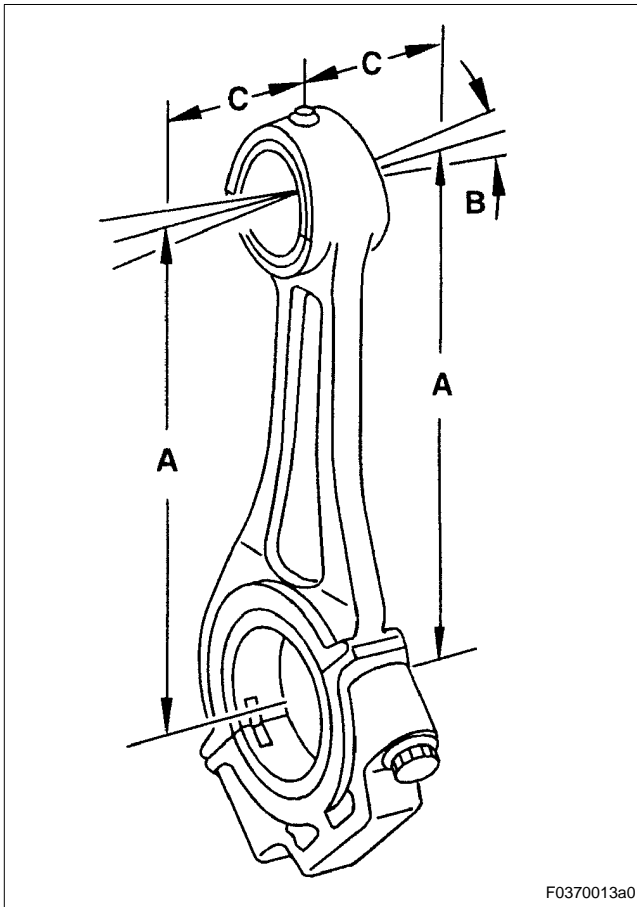

F0370013a0

Checking conrod twist

Measure permitted deviation (B) of bend between conrod bearing and conrod bushing bore to measuring distance (C).

Measure distance (A) from centre conrod bearing bore to centre conrod bushing bore.

For required measurements and limit values – see Tolerances and Wear Limits List.

If limit values are exceeded, replace conrod.

Note: Connecting rod must not be straightened!

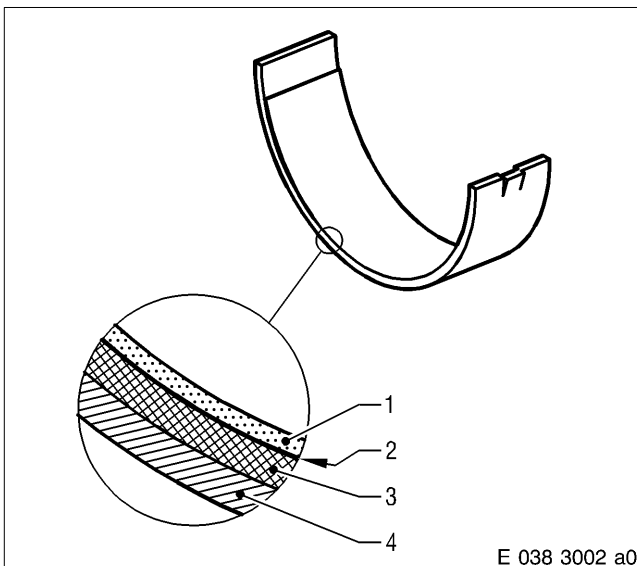

E 038 3002 a0

Checking and assessing conrod bearing shells

Check surface condition of bearing shells and check shells for wear. Replace worn or chipped bearing shells.

Replace bearing shells as part of every W6 overhaul.

Bearing shell has the following material structure:

- 1 Sliding layer (from 12 µm to 20 µm)
- 2 Intermediate layer (nickel barrier)
- 3 Bearing metal
- 4 Steel support shell

An important indicator for assessing extent of wear on bearing shell is the shape and extent of the nickel barrier areas exposed.

Use of bearing shell is reduced to 70 % of sliding layer in friction area!

Note: It is often difficult to differentiate between the hard nickel barrier and softer sliding layer. If in doubt, consult a bearing specialist.

Check condition of bearing shell butt and bearing reverse side and check for friction corrosion (pitting); if there is evidence of friction corrosion, replace bearing shell and determine cause.

Possible causes: Screws not sufficiently pretensioned, assembly fault, bearing shell spread dimension is outside tolerance limit and defective bearing support bore.

Measure bearing shells spread dimension.

If spread dimension is too low (see Tolerances and Wear Limits List), replace bearing shells.

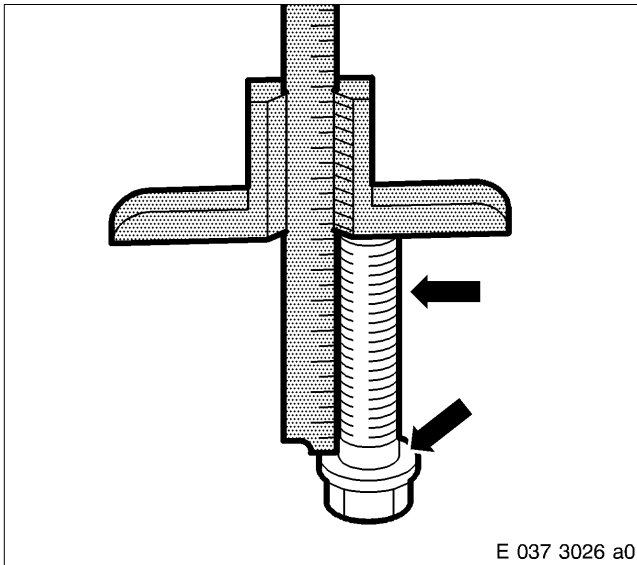

Checking conrod cap bolt

Note: Replace conrod bolts on a "cracked conrod" every time the engine is disassembled.

Check screw head support and thread (arrows) for scoring or damage; replace screw if necessary.

Measure shaft length of conrod bolt with depth gauge.

For max. permissible shaft length, see C 037.05.01.

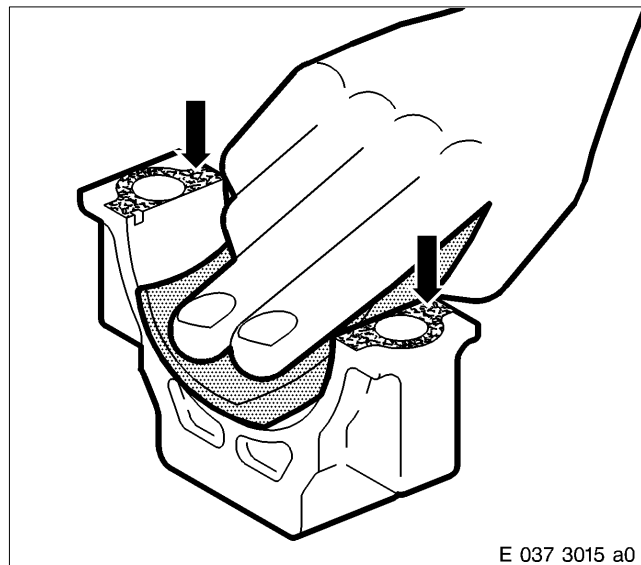

Installing conrod bearing shells

CAUTION

Compressed air is air which has been compressed under pressure. Risk of injury.

If compressed air is used for blowing out or blow-drying components, always wear protective goggles or safety mask.

Compressed air must not be directed at the body. Pressure must not exceed 3.0 bar (40 lb/in²).

Blow out interfaces (arrows) on connecting rod and conrod cap with compressed air and check that they are clean.

The cracked (broken) interfaces must not be damaged; replace connecting rod as necessary.

Wipe bearing shell mating faces on connecting rod and conrod cap.

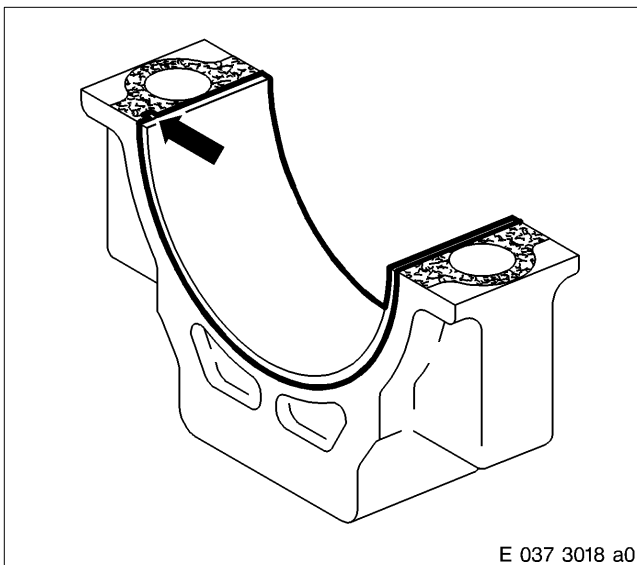

Note: New conrod bearing shells must be installed as part of every W6 overhaul.

Prior to installing conrod bearing shells, compare repair stage marking on connecting rod and in crankshaft data sheet.

Mark conrod bearing shells according to cylinder number on front face.

Wipe conrod bearing shell on both sides and insert into conrod bearing cover.

Securing lug (arrow) of conrod bearing shell must sit in groove in conrod bearing cover.

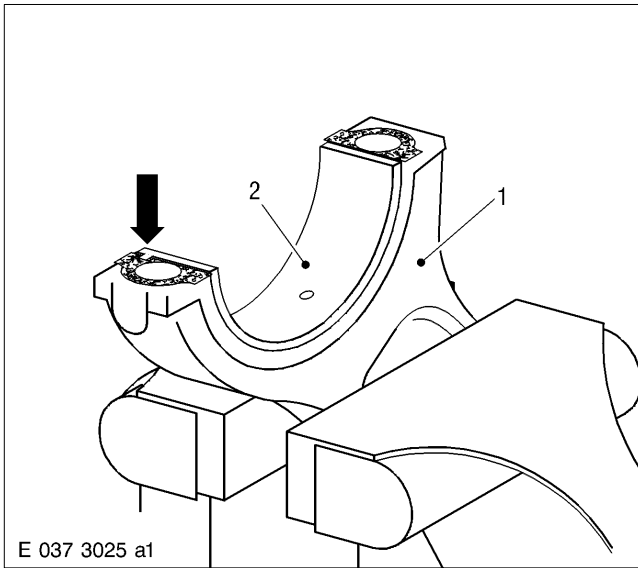

Clamp conrod (1) in vice with aluminium jaws.

Wipe conrod bearing shell (2) on both sides and insert into conrod.

Securing lug (arrow) of conrod bearing shell must sit in the groove of the connecting rod and the bore in the conrod bearing shell and conrod must be aligned.

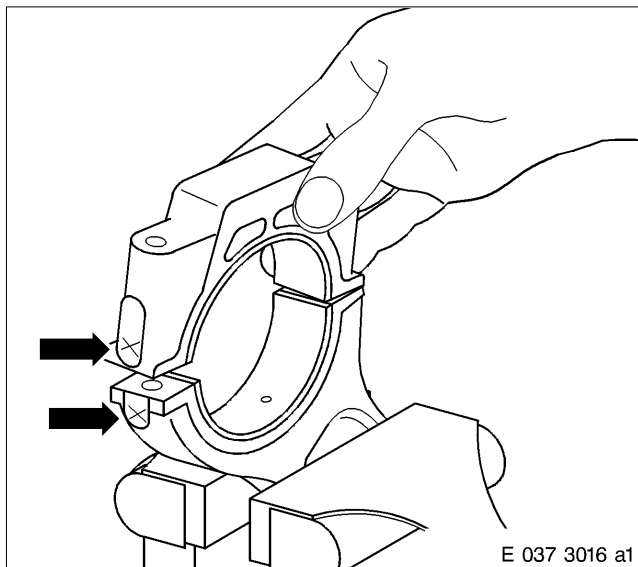

Place conrod cap in position on conrod, making sure that serial numbers (arrows) are aligned.

Coat threads of screw head mating face and bolt head seating surfaces with engine oil.

Fit conrod cap bolts.

Note: Manually press conrod cap into place when installing conrod bolts.

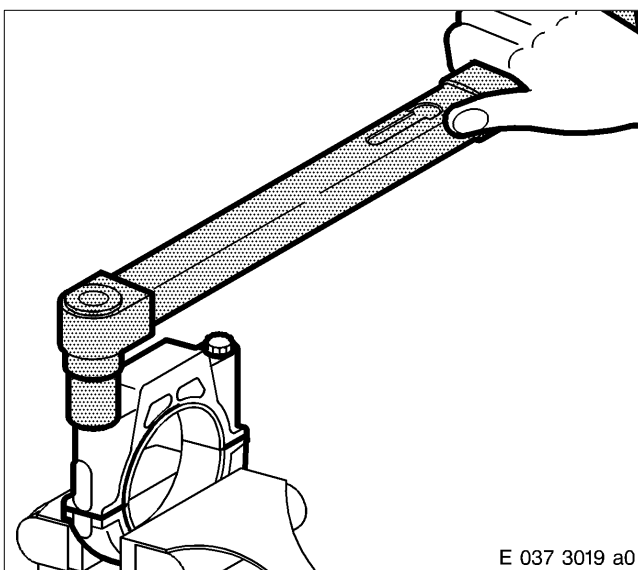

To avoid twisting the conrod, clamp conrod in vice according to diagram.

Pretighten conrod bolts with torque wrench and socket to specified pretightening torque, see C 037.05.01.

Mark screw heads.

Tighten conrod screws through specified angle of further rotation.

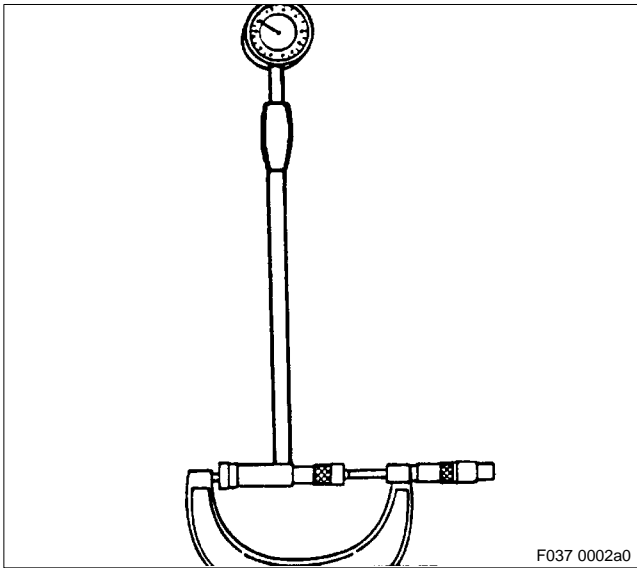

Adjust bore gauge and dial gauge with micrometer to basic size for conrod bearing bore as per Tolerances and Wear Limits List.

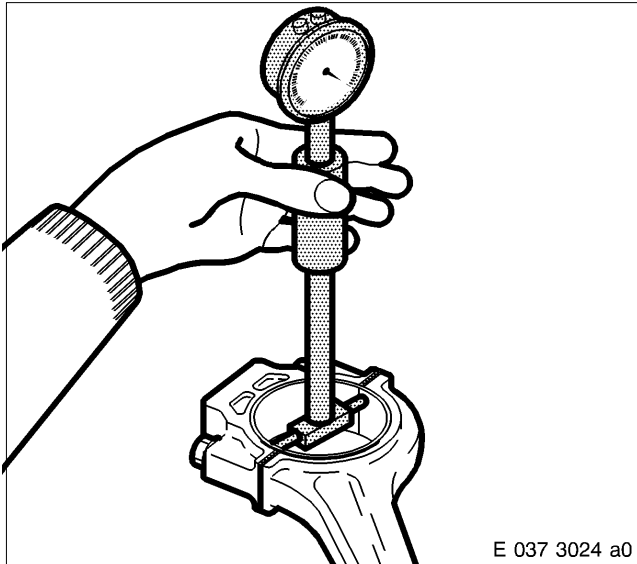

Coat sliding surfaces of bearing shells with engine oil.

Measure conrod bearing bore of conrod.

For limit values and measuring planes – see Tolerances and Wear Limits List.

Enter measurement values in data sheet.

If limits values are exceeded or not achieved, replace bearing shells or machine conrod basic bore to repair size.

Note: Conrod bearing shells are ready for installation when supplied. No reconditioning must be carried out.

Remove conrod bolts, conrod cap and bearing shells.

Protect bearing shells from damage!

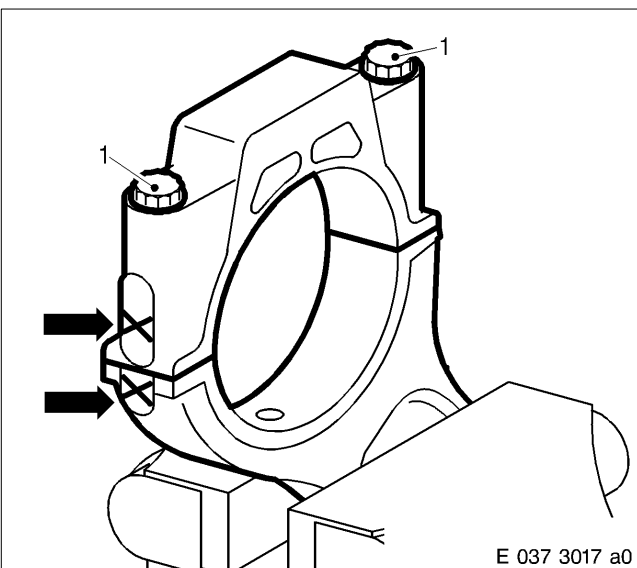

Measuring conrod basic bore

Note: Never screw conrod bearing cap tight without conrod bearing shells.

Correctly fit conrod cap on connecting rod.

Check that markings (arrows) for conrod cap to conrod are aligned.

Manually press conrod cap into place, insert conrod bolt (1) and tighten (10 to 20 Nm).

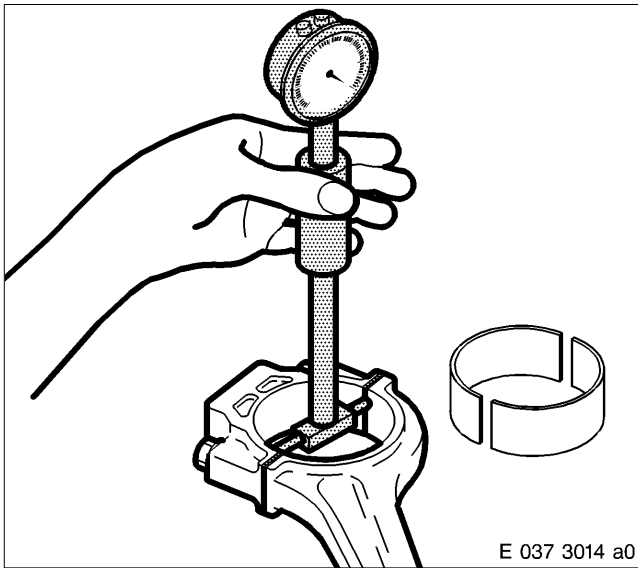

Adjust bore gauge to basic size conrod bearing bore and measure.

For basic size of conrod basic bore, limit values and measuring points – see Tolerances and Wear Limits List.

If limit values are exceeded, machine conrod main bore to repair size or replace conrod.

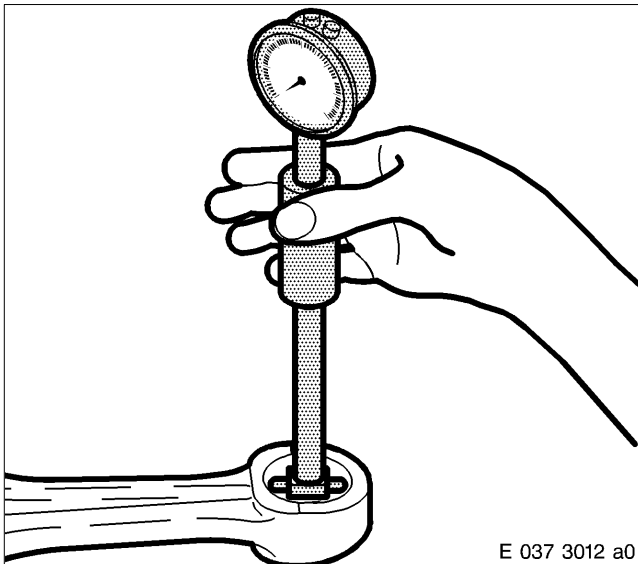

Measuring conrod bushing bore

Adjust bore gauge to zero dimension for conrod bush bore as per Tolerances and Wear Limits List and measure bore of conrod bush.

If limit values are exceeded, replace conrod bush.

It is imperative to contact MTU and/or DDC.

C 037.05.10 Assembly

Note: Always make sure that all components are perfectly clean.

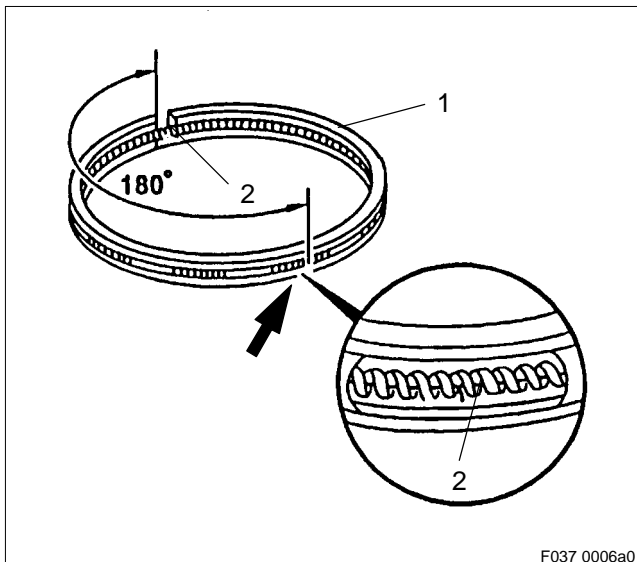

Installing piston rings

Turn coiled spring expander (2) in oil scraper ring (1) to offset ring spring butting face (arrow) to oil scraper ring butt by 180°.

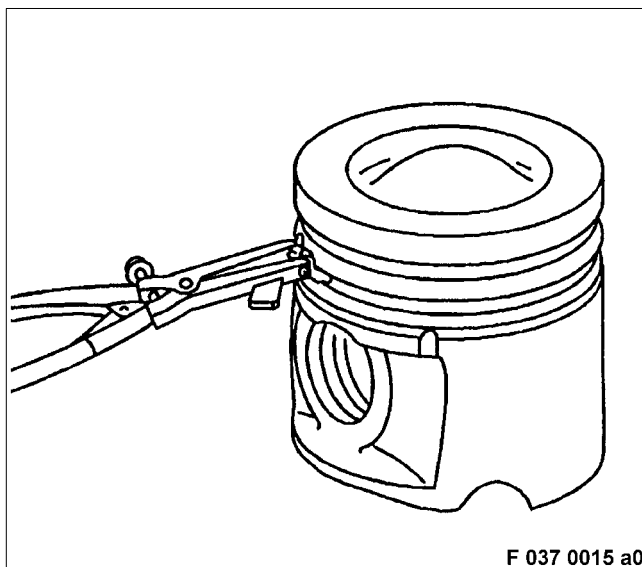

In sequence from bottom to top (oil scraper ring first), insert piston rings with piston ring pliers into annular grooves on piston.

Note: Stretch piston rings (arrows) only until they can be fitted over the piston. Do not overstretch piston rings, as they may break.

Make sure piston rings are installed in correct sequence – see next illustration.

TOP marking on piston rings must point upwards.

Note: Oil scraper ring does not have a TOP marking, installation position as required.

Check that piston rings move freely in their grooves.

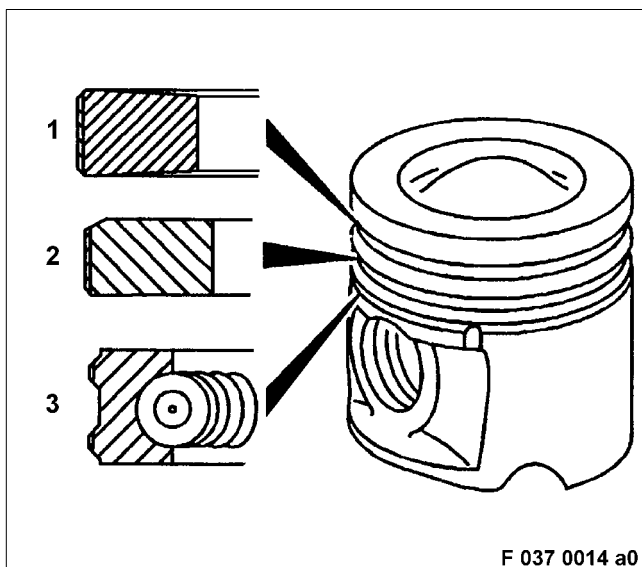

Sequence of piston rings:

1 – Keystone-type compression ring

2 – Taper-face compression ring

3 – Oil scraper ring

Note: Piston rings must only be replaced in sets. Hone cylinder liners if new piston rings are installed.

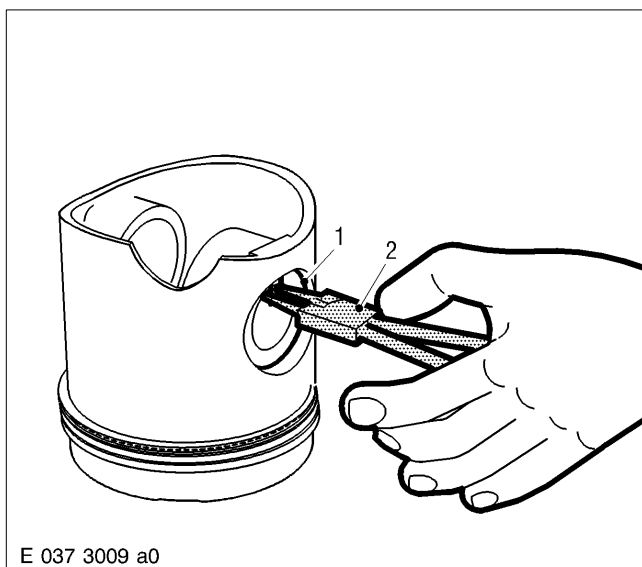

Installing conrod in piston

! CAUTION

Snap ring pretension

Risk of injury.

Use suitable circlip pliers. Always wear protective goggles/safety mask.

Using circlip pliers (2), insert snap ring (1) into piston boss.

Note: Make sure snap ring is perfectly seated in groove. Snap ring must be seated securely in the groove.

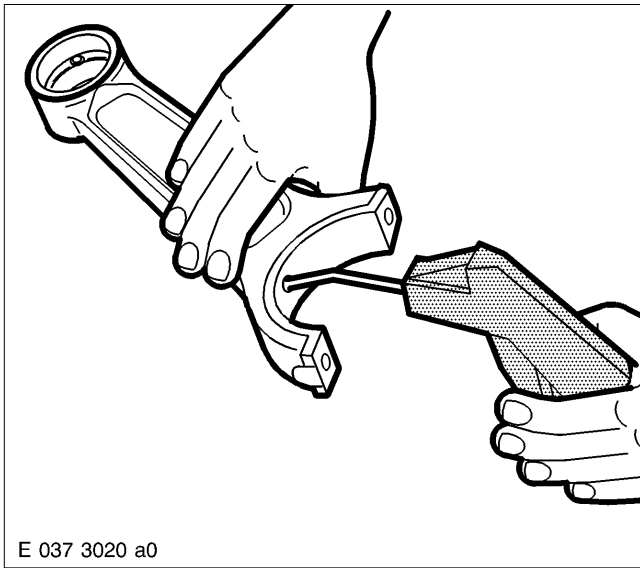

CAUTION

Compressed air is air which has been compressed under pressure. Risk of injury. If compressed air is used for blowing out or blow-drying components, always wear protective goggles or safety mask. Compressed air must not be directed at the body. Pressure must not exceed 3.0 bar (40 lb/in²).

Blow through lube oil bores in conrod with compressed air and ensure that they are perfectly clean.

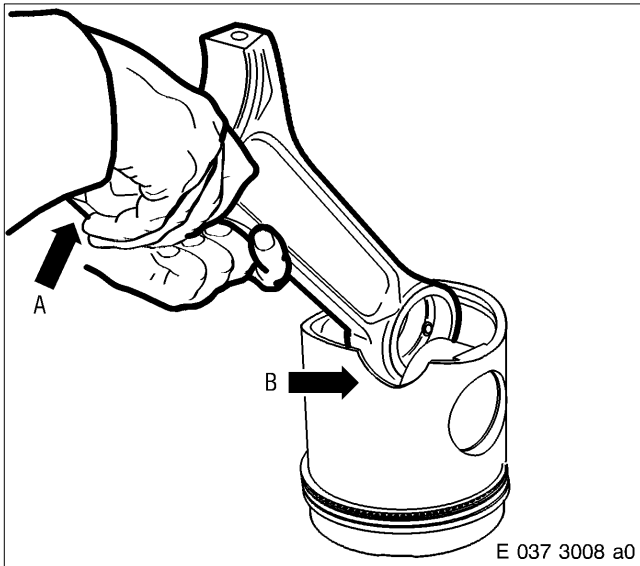

Wipe down piston pin, conrod bushing and piston pin bore with chamois leather and coat with engine oil.

Insert conrod according to markings into relevant piston in such a way that the longer end (A) of the angle-split conrod faces recess (B) for oil spray nozzle.

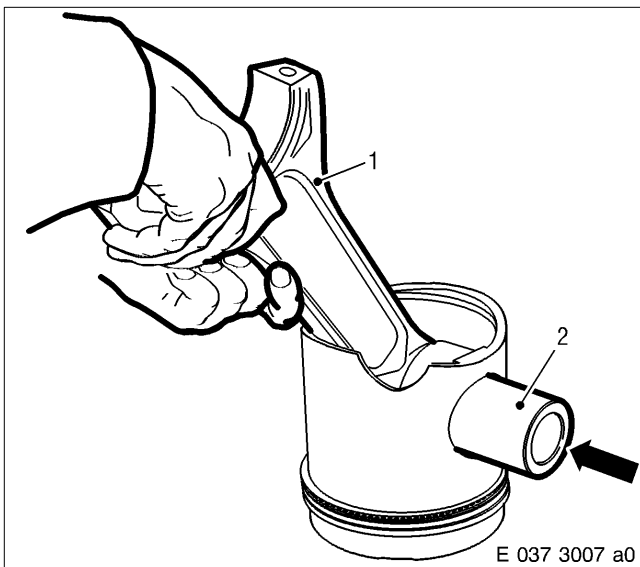

Push associated piston pin (2) into piston and conrod (1) until seated against snap ring installed beforehand (arrow).

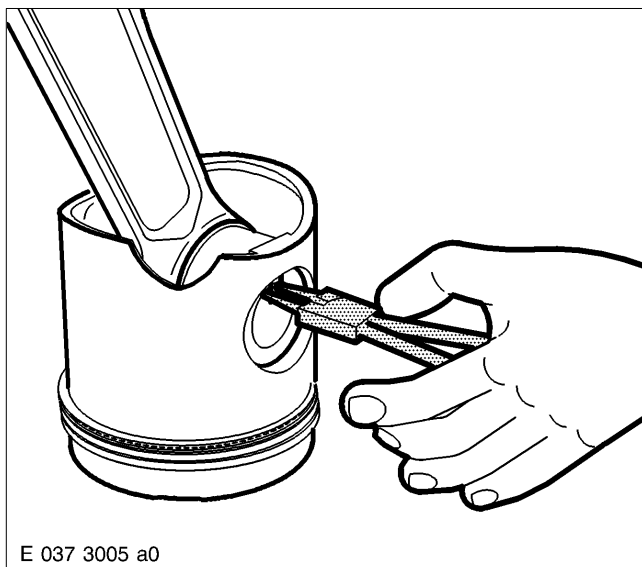

⚠ CAUTION

Snap ring pretension
Risk of injury.
Use suitable circlip pliers. Always wear protective goggles/safety mask.

Insert second snap ring with circlip pliers.

Note: Make sure snap ring is perfectly seated in groove. Snap ring must be seated securely in the groove.

C 037.05.11 Installation

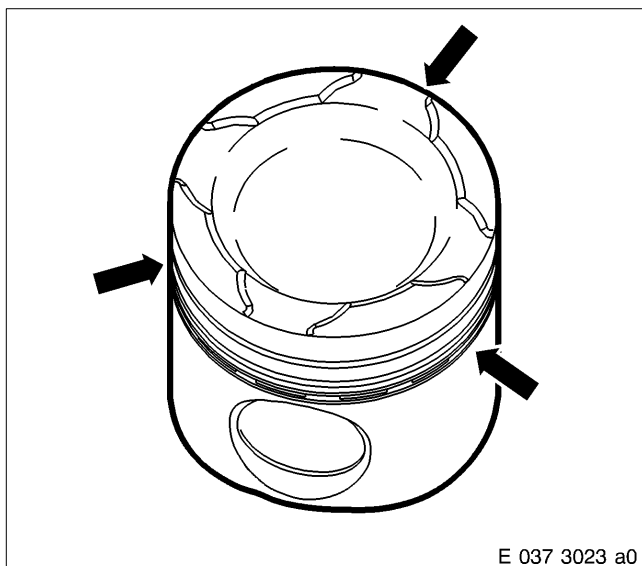

Installing piston with conrod in assembly dolly

Note: Always make sure that all components are perfectly clean.

Spray the piston and piston rings with engine oil.
Position piston ring butts (arrows) consecutively at 120° intervals.

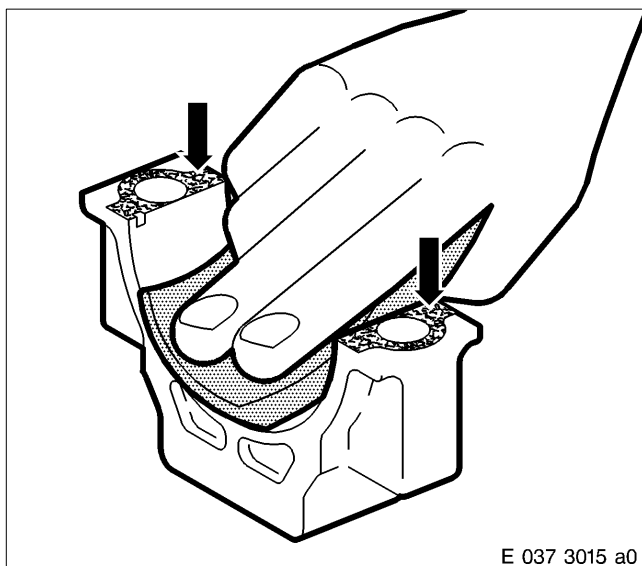

⚠ CAUTION

Compressed air is air which has been compressed under pressure. Risk of injury.
If compressed air is used for blowing out or blow-drying components, always wear protective goggles or safety mask.
Compressed air must not be directed at the body.
Pressure must not exceed 3.0 bar (40 lb/in²).

Blow out interfaces (arrows) on connecting rod and conrod cap with compressed air and check that they are clean.

The cracked (broken) interfaces must not be damaged; replace connecting rod as necessary.

Wipe bearing shell mating faces on connecting rod and conrod cap.

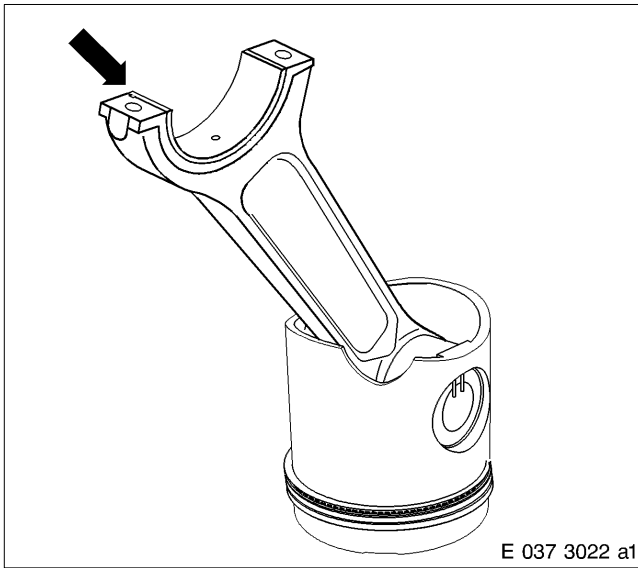

Wipe conrod bearing shell on both sides and install into conrod in accordance with their markings.

Note: Prior to installing bearing shell, note respective stage on connecting rod and crankshaft journal – see data sheets.

Securing lug (arrow) of conrod bearing shell must sit in groove in conrod.

Bore in the conrod bearing shell and conrod must be aligned.

Coat friction face of conrod bearing shell with engine oil.

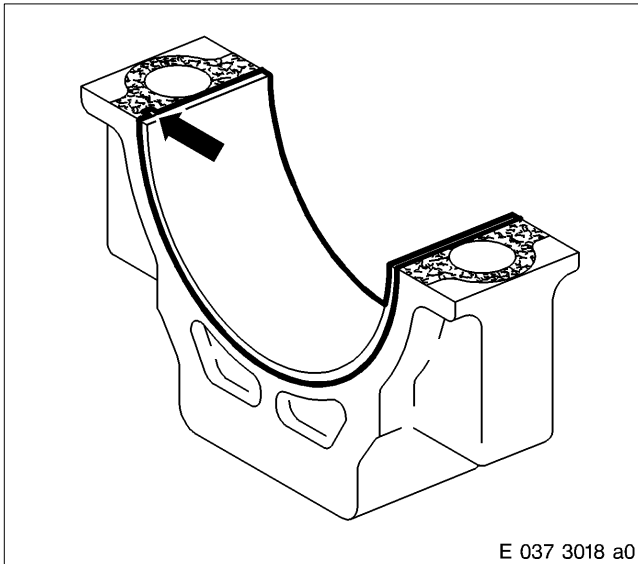

Wipe conrod bearing shell on both sides and install into conrod cover in accordance with their markings.

Securing lug (arrow) of conrod bearing shell must sit in groove in conrod cap.

Coat friction face of conrod bearing shell with engine oil.

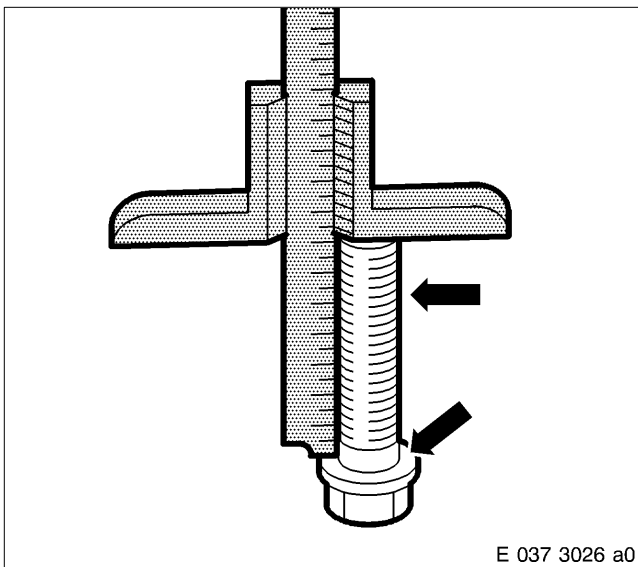

Note: Replace conrod bolts on a "cracked conrod" every time the engine is disassembled.

Measure shaft length of conrod bolts; for max. shaft length – see C 037.05.01.

Coat threads and screw head seating surfaces (arrows) with engine oil.

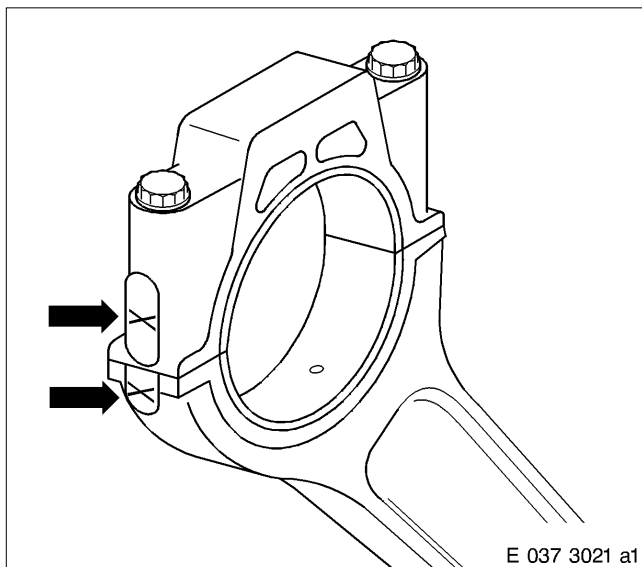

Check that markings (arrows) for conrod cap to conrod are aligned.

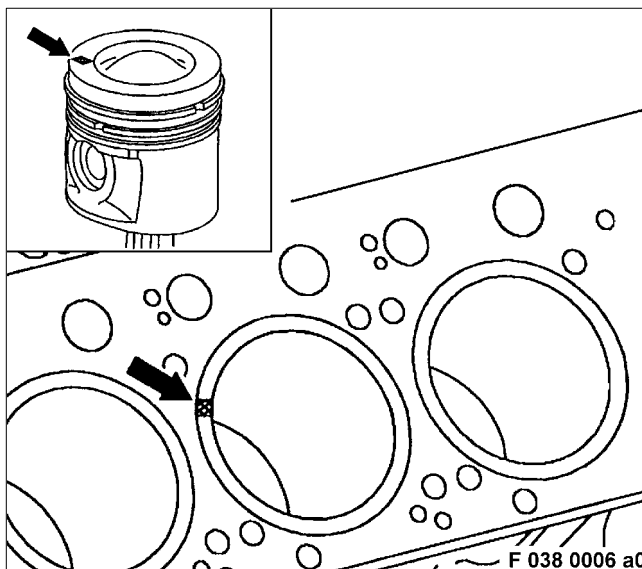

If new pistons are installed, assign each piston to the respective cylinder liner in accordance with the tolerance group designation.

The tolerance group designation (arrows) is stamped on the piston crown and edge of liner.

Designation

- Piston ⇒ Cylinder liner
- BA ⇒ A or B
- BC ⇒ B or C

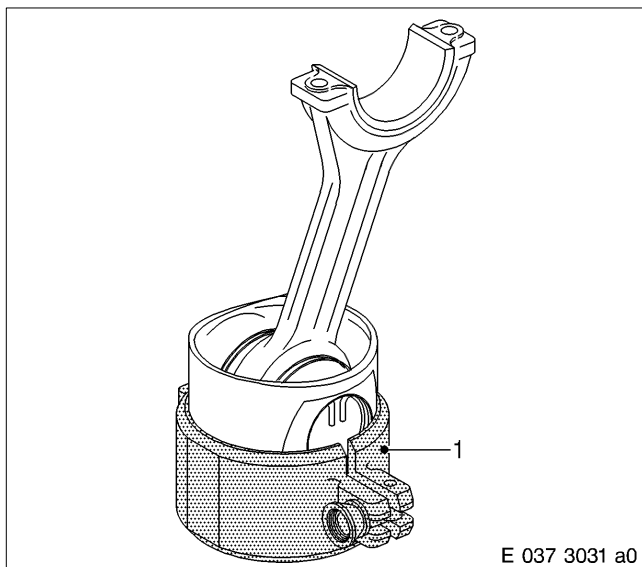

Install piston ring band clamp (1) over the piston rings as shown in the illustration.

Note: Check radial mobility of piston ring band clamp. The band clamp must turn easily; if this is not the case, remove it and check the piston rings.

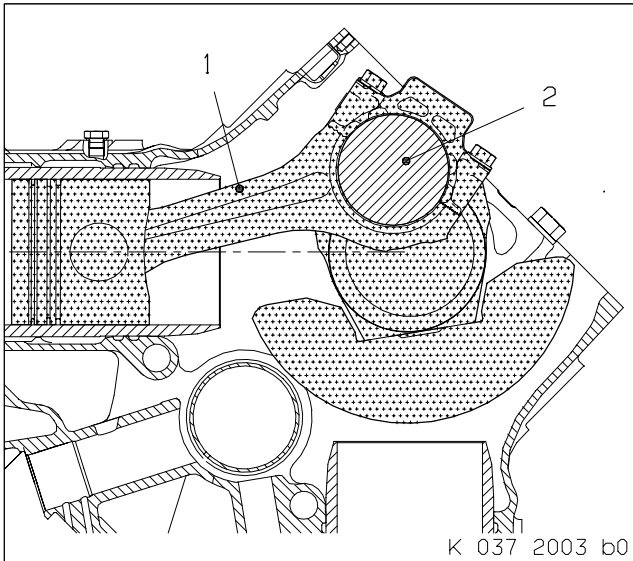

Rotate crankcase in assembly dolly until cylinder liners are horizontal.
Turn crankpin (2) of crankshaft of piston to be installed and connecting rod (1) according to sketch to assembly position.
Wipe crankpin and running surface of cylinder liner and spray with engine oil.
Insert piston according to markings in associated cylinder liner until the piston ring band clamp is in contact with the cylinder liner.

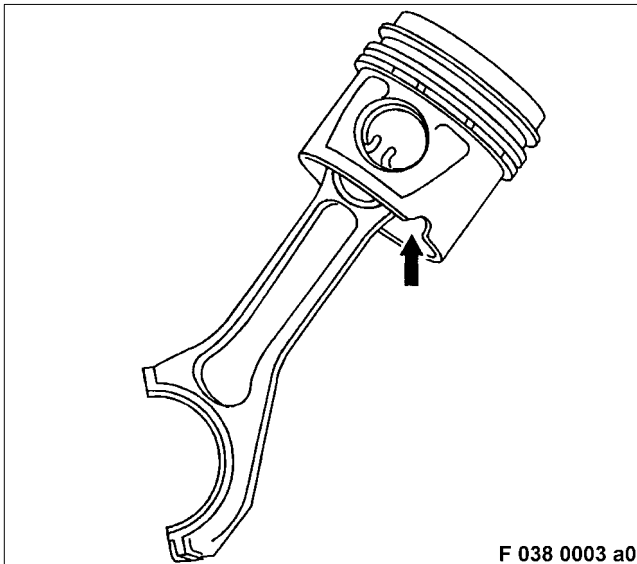

The recess (arrow) for the oil spray nozzle on the piston points inwards to the engine centre.

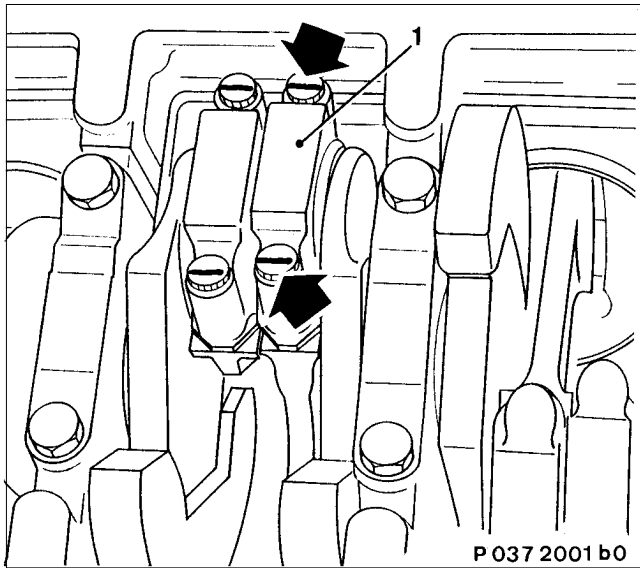

Note: In order to guide the conrod and avoid damage to the oil spray nozzle, piston installation must be carried out by two people.

Gently turn piston when inserting so that the oil spray nozzle is not damaged when the conrod is installed.

If the oil spray nozzle is damaged, remove spray nozzle and replace.

Press in piston until the conrod bearing shell fits exactly on crankpin of crankshaft, turn crankshaft if necessary.

Remove piston ring band clamp.

Fit conrod cap (1) correctly (marking must be on one side) and manually insert conrod bolts.

Note: Manually press conrod cap into place when installing conrod bolts.

Pretighten conrod bolts with torque wrench and socket to specified pretightening torque – see C 037.05.01.

Check that conrod has axial play.

If there is no axial clearance, remove conrod cap and replace damaged bearing shell.

Mark screw heads (arrows).

Tighten conrod screws through specified angle of further rotation.

Check that conrod has axial play.

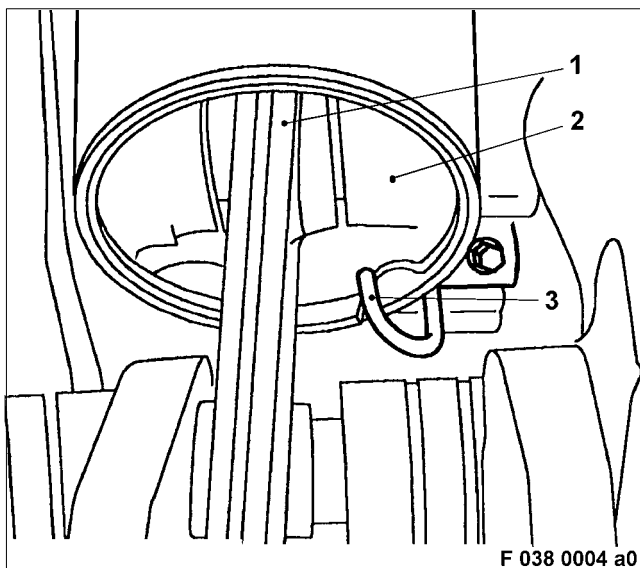

Bar crankshaft and ensure that there is ease of movement between oil spray nozzle (3), piston (2) and conrod (1).

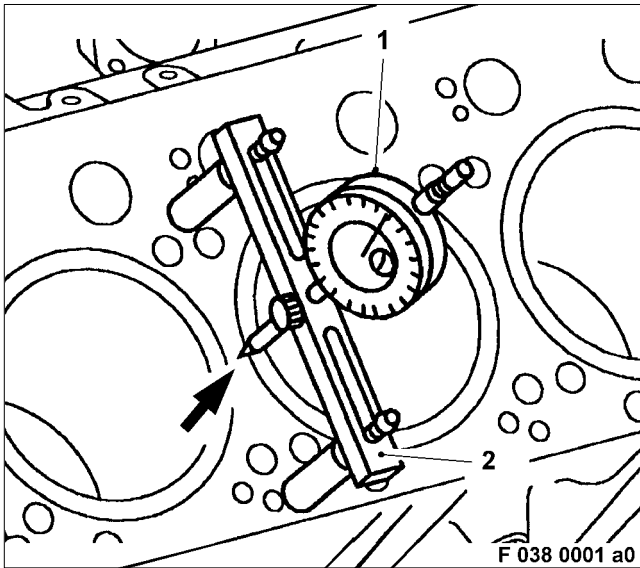

Measuring piston protrusion

Note: Measure protrusion between piston crown and crankcase partition without the cylinder head gasket in position.
To eliminate piston-tilt clearance, perform measurements in direction of piston pin.

Clean residues from piston and crankcase partition.
Turn the crankshaft slowly in engine direction of rotation until the piston being measured is approx. 1 cm before TDC.

Secure dial gauge (1) with pretension in the bridge meter (2).

Position bridge meter and dial gauge stylus (arrow) on crankcase partition and set dial gauge scale to zero.

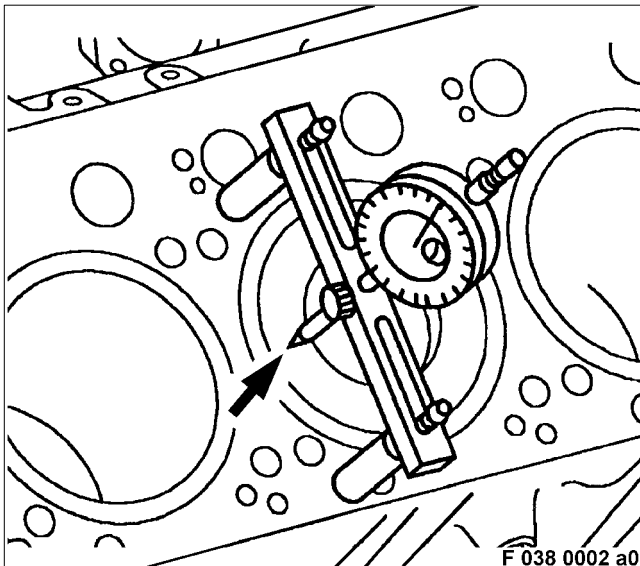

Move bridge meter and feeler from the crankcase partition over the outer piston face (arrow); hold back the dial gauge stylus while doing this.

Turn the crankshaft slowly in engine direction of rotation until the dial gauge pointer no longer moves or the piston is precisely at TDC.

Read off and make a note of piston protrusion at dial gauge.

Measure piston protrusion of all pistons in the same way.

For specified values – see Tolerances and Wear Limits List.

If the tolerance deviation is impermissible, check the affected conrod and replace if necessary.

C 037.05.12 After-Installation Operations

A distinction must be made as to whether:

- 1 ————— The engine is to be completely disassembled
- 2 ————— The engine is to be removed but not disassembled
- 3 ————— The engine is to remain installed

1	2	3	Operations	See
x	-	-	Perform operations as per Assembly Plan	B 005
x	-	-	Install engine	B 007
-	x	x	Install oil pan	C 014.05
-	x	x	Install cylinder head	C 041.05
-	x	x	Install pushrods	C 054.05
-	x	x	Install rocker arm assembly	C 055.05
-	x	x	Adjust valve clearance	C 055.05.11
-	x	x	Connect leak-off fuel lines	C 086.05
-	x	x	Install H.P. fuel line	C 073.05
-	x	x	Install cylinder head cover	C 055.10
-	x	x	Install exhaust manifold	C 142.05
-	x	x	Install turbocharger	C 101.01
-	x	x	Install charge air manifold	C 124.05
-	x	x	Connect electric cables	-
-	x	x	Install crankcase breather	C 018.10
-	x	x	Install air pipework before exhaust turbocharger	-
-	-	x	Fill oil system with engine oil	Operating Instructions
-	-	x	Fill engine coolant system	Operating Instructions
-	-	x	Release engine start	Operating Instructions



Contents

C 040	Cylinder head with fixtures
C 041.05	Cylinder head
C 041.05.01	General view
C 041.05.02	Special tool
C 041.05.04	Before-removal operations
C 041.05.05	Removal
C 041.05.06	Disassembly
C 041.05.08	Inspection and Repair
C 041.05.10	Assembly
C 041.05.11	Installation
C 041.05.12	After-installation operations

C 040 Cylinder Head with fixtures

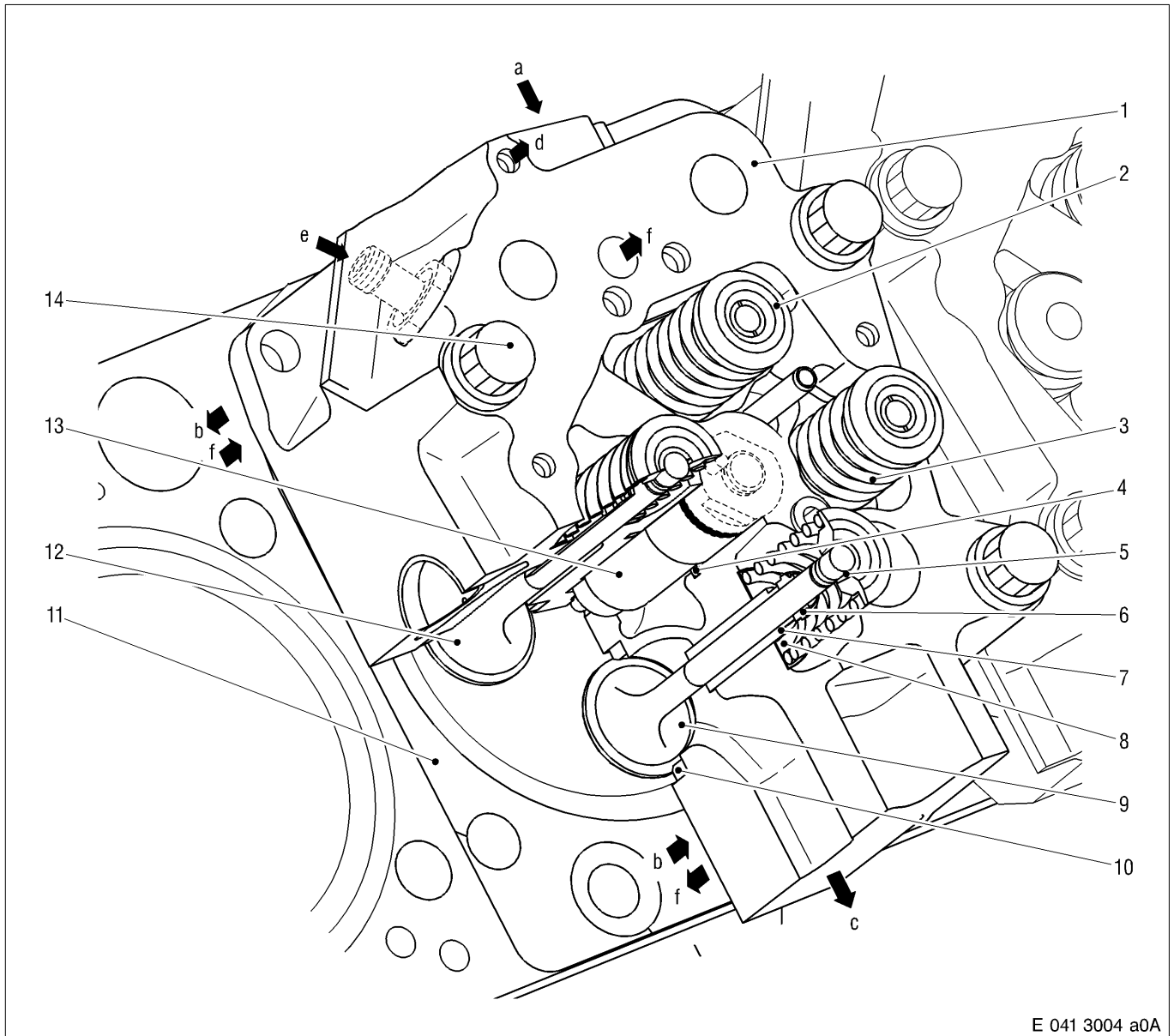

E 041 3004 a0A

- | | | |
|-------------------------|-------------------------------|------------------|
| 1 Cylinder head | 8 Washer | a Charge air |
| 2 Valve spring retainer | 9 Exhaust valve | b Engine coolant |
| 3 Valve spring | 10 Valve seat insert, exhaust | c Exhaust |
| 4 O-ring | 11 Cylinder head gasket | d Leak-off fuel |
| 5 Valve collet | 12 Exhaust valve | e Fuel supply |
| 6 Valve shaft gasket | 13 Protective sleeve | f Engine oil |
| 7 Valve guide | 14 Double-hex screw | |

The following is a list of auxiliary equipment and materials needed for the assembly operations:

	CAUTION
<p>When using these miscellaneous materials, it is essential to observe the Manufacturer's Instructions for use, safety instructions and waste disposal specifications.</p>	

Materials and consumables	Designation	Order No.		Remarks
		MTU	DDC	
Emery cloth				
Rotary wire brush				
Valve guide cleaning brush				
Magnifying glass				
Spray gun				
Inspection lamp				
Liquid nitrogen				
Activator	Loctite No. 7649	50548		
Vaseline	Petroleum jelly, white	40317		
Thread-locking compound	Loctite no. 270	40083		Final strength at 20 °C ≈ 12 h
Engine oil				
Cleaning agent (carbon-deposit remover)	Meister Proper	40377		
Cleaning agent	Solvclean KW	40022		
Corrosion preventive	Caramba Express	40008		
Kerosene or diesel fuel				
Denaturated ethanol		40250		
Multipurpose grease	Shell Retinax A	40333		
Dry compressed air				
Surface crack-testing equipment with red penetrant dye				
Surface crack-testing equipment with fluorescent penetrant dye				



C 041.05 Cylinder Head

C 041.05.01 General View

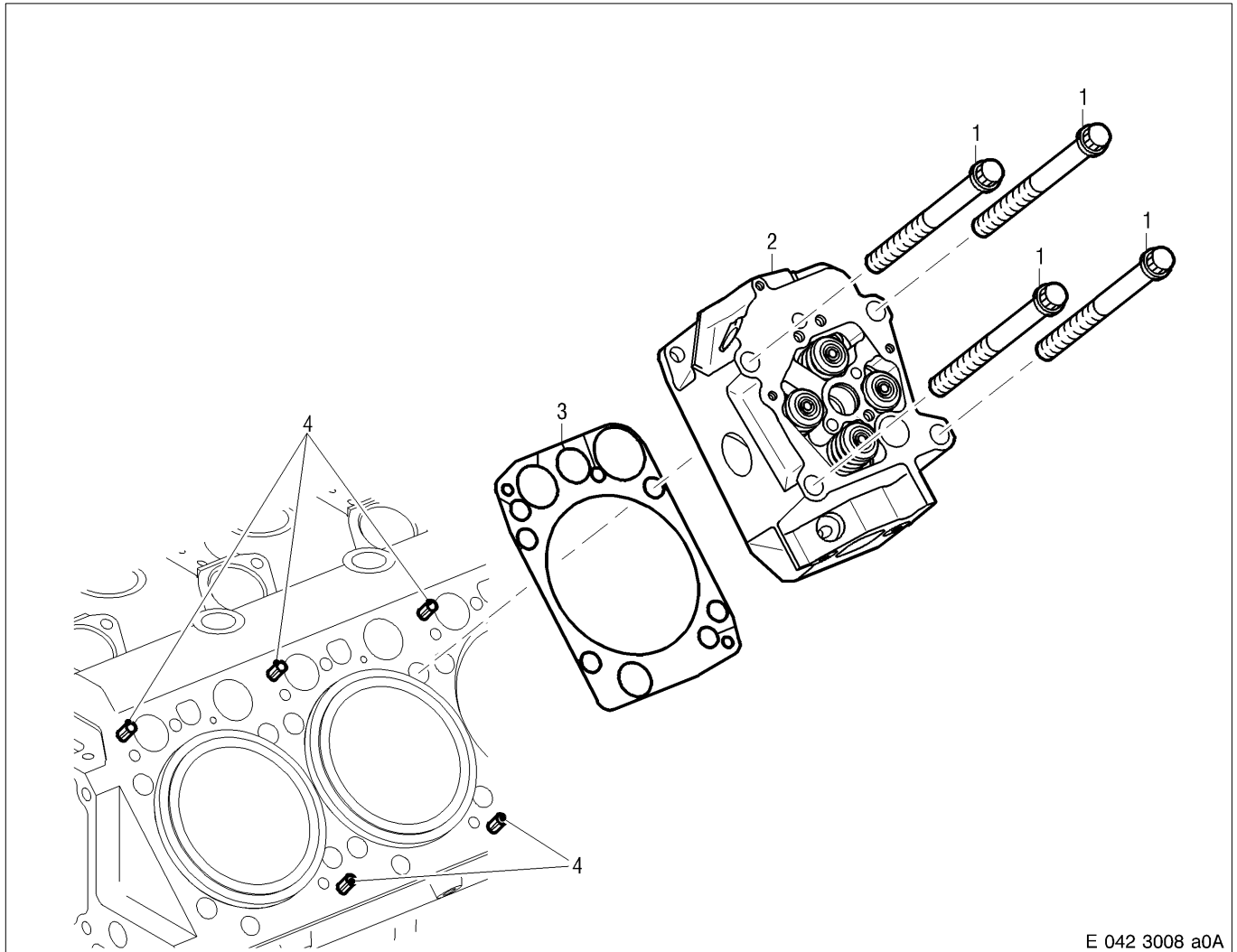

E 042 3008 a0A

- 1 Double-hex screw
For tightening torque – see next illustration
- 2 Cylinder head
- 3 Cylinder head gasket
- 4 Spring pin

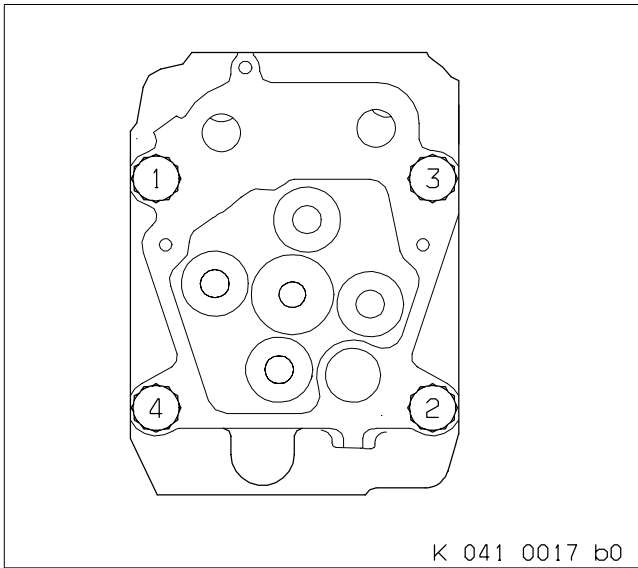

Cylinder head tightening diagram

Max. shaft length: 212 mm

Pretightening torque, in stages:

- 1st stage 10 Nm
- 2nd stage 50 Nm
- 3rd stage 100 Nm
- 4th stage 200 Nm

Angle of further rotation, in stages:

- 1st stage 90° + 10°
- 2nd stage 90° + 10°

Lubricant: Engine oil

K 041 0017 b0

Cylinder head with valves

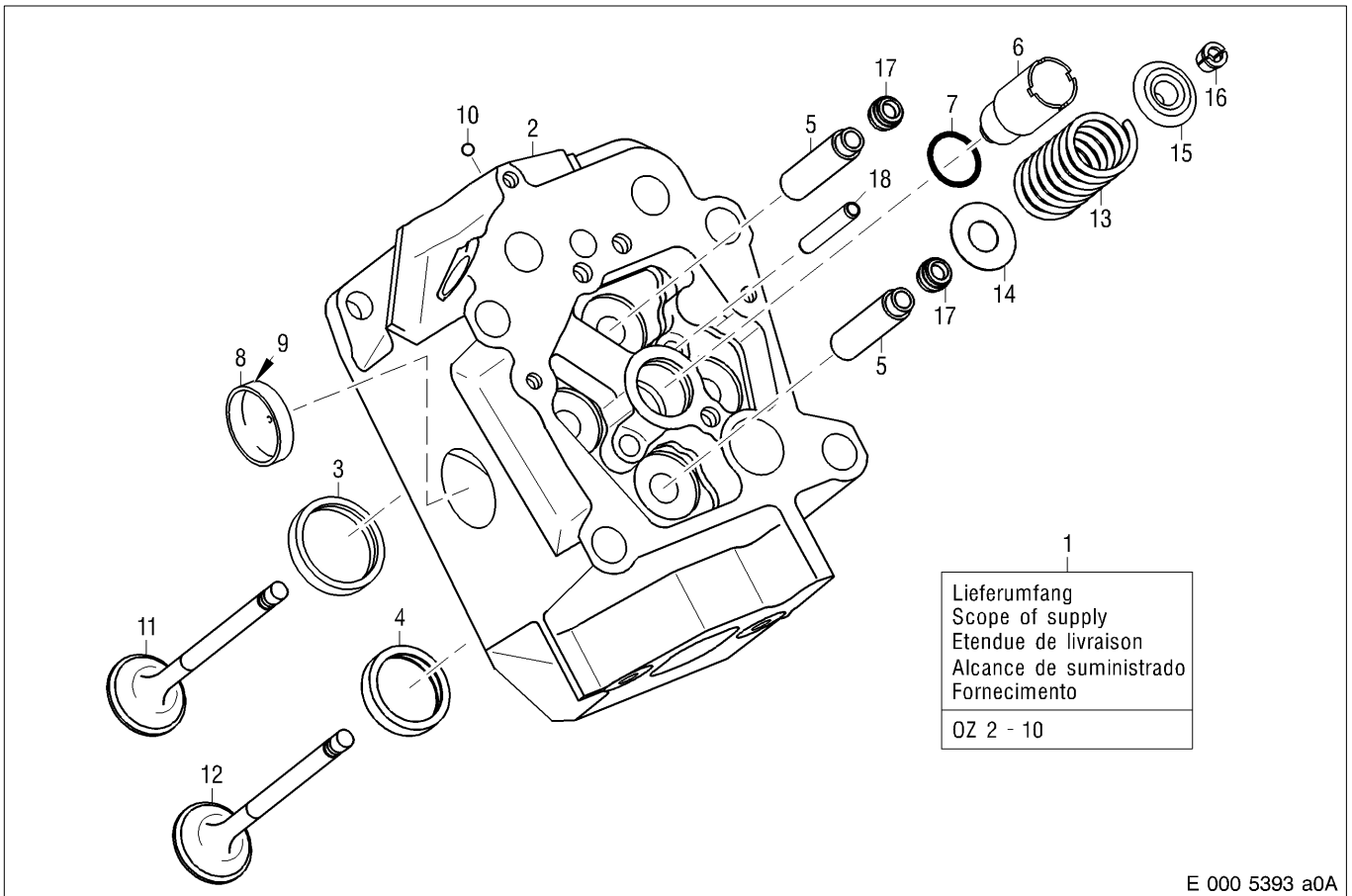

E 000 5393 a0A

- | | | | |
|-----------------------------|------------------------------------|------------------------|--------------------------|
| 1 - | 6 Protective sleeve | 9 Thread-locking agent | 14 Valve spring seat |
| 2 Cylinder head | Tightening torque:
40 Nm + 5 Nm | 10 Ball | 15 Valve spring retainer |
| 3 Valve seat insert, inlet | Lubricant: Engine oil | 11 Valve, inlet | 16 Valve collets |
| 4 Valve seat insert, outlet | 7 O-ring | 12 Valve, outlet | 17 Valve shaft gasket |
| 5 Valve guide | 8 End cover | 13 Valve spring | 18 Pin |

Cylinder head without valves

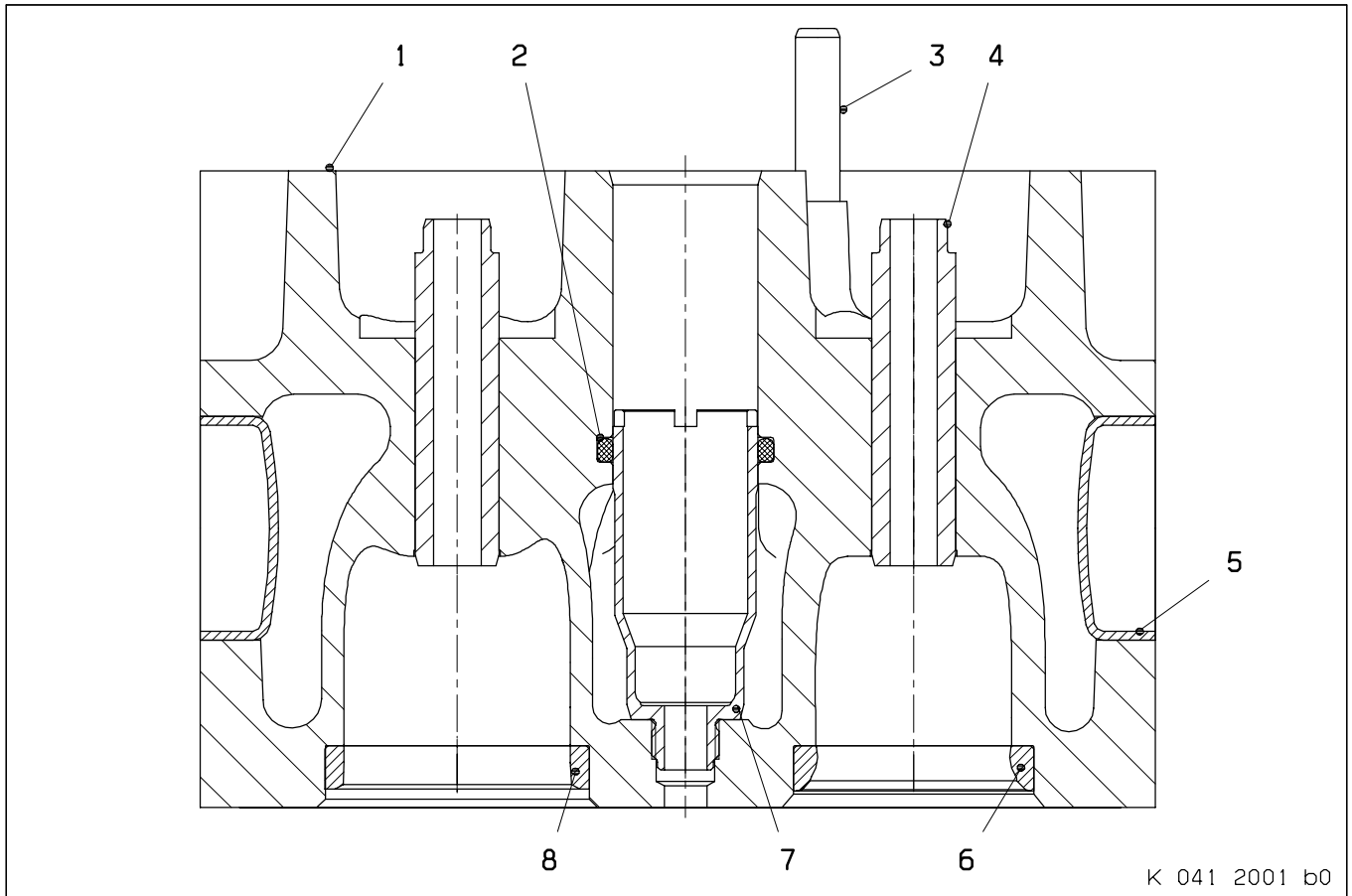

- | | | |
|-----------------|-----------------------------|---------------------------------|
| 1 Cylinder head | 4 Valve guide | 7 Protective sleeve |
| 2 O-ring | 5 End cover | Tightening torque: 40 Nm + 5 Nm |
| 3 Pin | 6 Valve seat insert, outlet | Lubricant: Engine oil |
| | 8 Valve seat insert, inlet | |

Arrangement of valve guides in cylinder head

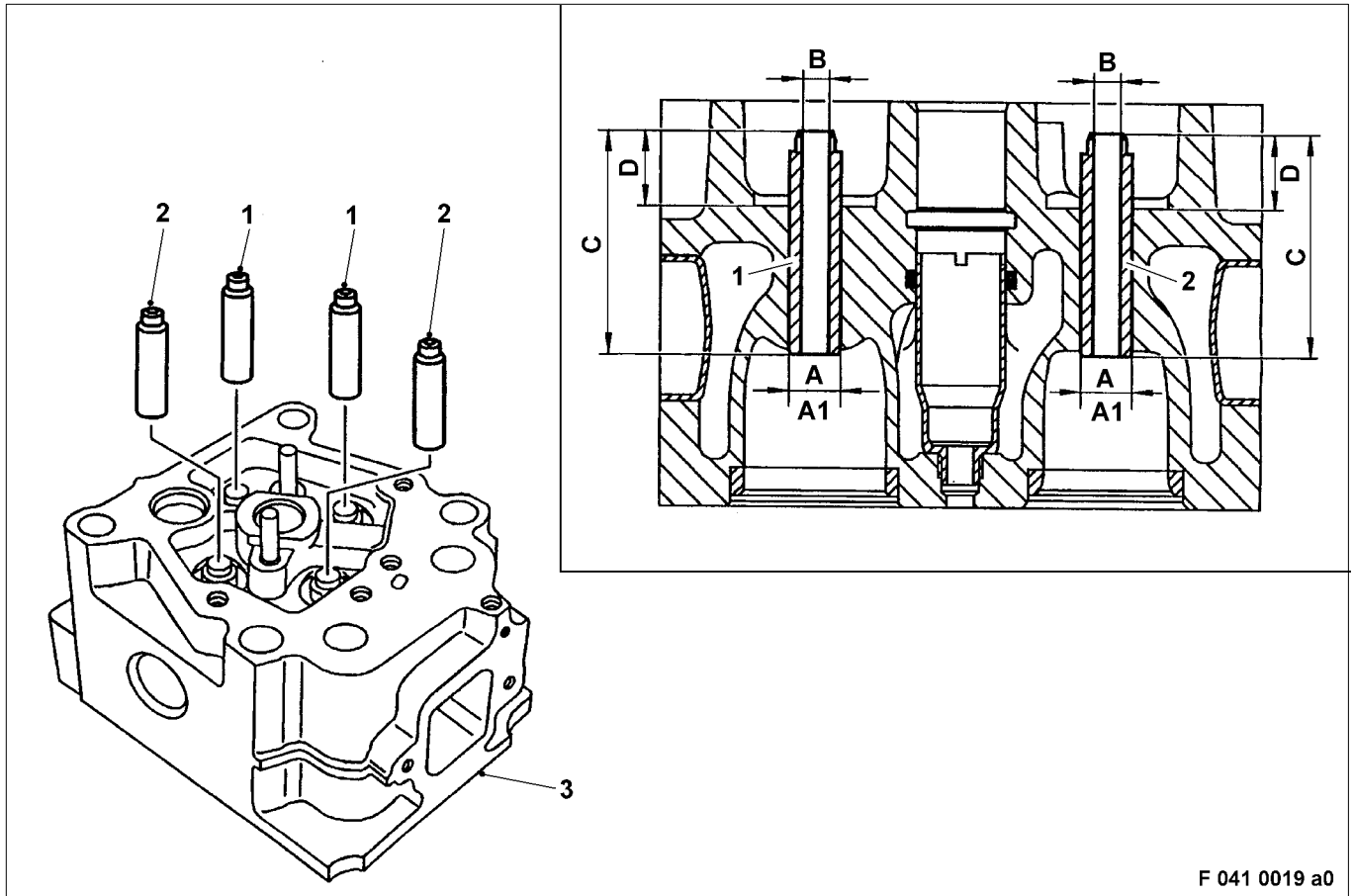

- 1 Valve guide – inlet valve
- 2 Valve guide – exhaust valve
- 3 Cylinder head

- A Valve guide – bore diameter in cylinder head
- A1 Valve guide – outside diameter
- B Valve guide – inside diameter

- C Valve guide – length
- D Distance from valve guide top edge to valve spring mating surface

Arrangement of valve seat inserts in cylinder head

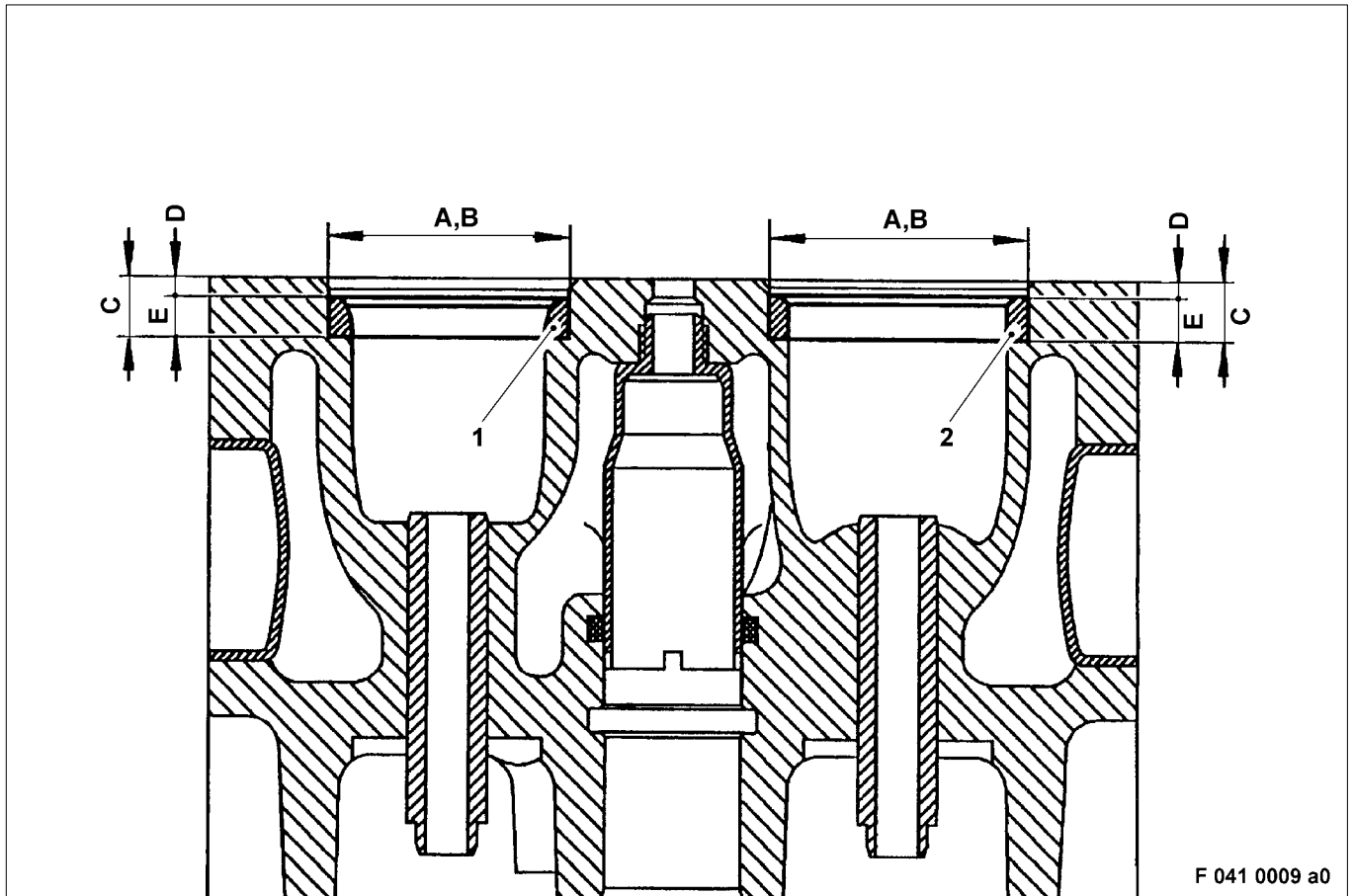

F 041 0009 a0

- | | | |
|-----------------------------|--|---|
| 1 Valve seat insert, outlet | A Valve seat insert, outside diameter | D Distance between cylinder head partition and valve seat insert end face |
| 2 Valve seat insert, inlet | B Bore diameter of valve seat inserts in cylinder head | E Valve seat insert, height |
| | C Bore depth of valve seat inserts in cylinder head | |

C 041.05.02 Special Tool

Designation – Application	Number
Socket for cylinder head screws	1
Socket for protective sleeve	1
Alignment rail for cylinder heads	1
Valve installation and removal tool	1
Valve seat rotating unit VDS 2	1
Test kit for valve seats	1
Mandrel for end cover	1
Internal extractor and counter supports for valve seat	1
Removal mandrel for valve guides	1
Mandrel and spacer bush, valve guide installation	1
Mandrel for valve seat installation	1
Mandrel for valve stem seal	1
Sleeve for valve stem seal	1
Plug gauge for valve guides	1
Reamer for valve guides	1

C 041.05.04 Before-Removal Operations

A distinction must be made as to whether:

- 1 ————— The engine is to be completely disassembled
- 2 ——— The engine is to be removed but not disassembled
- 3 — The engine is to remain installed

1	2	3	Operations	See
x	–	–	Remove engine	B 003
x	–	–	Perform operations as per Disassembly Plan	B 004
–	–	x	Disable engine start	Operating Instructions
–	–	x	Drain engine coolant	Operating Instructions
–	x	x	Remove guide tube and oil dipstick (as required)	C 182.10
–	x	x	Remove filling pipe for engine oil (if necessary)	C 182.10
–	x	x	Remove air supply system before turbocharger (if necessary)	–
–	x	x	Release or remove charge air manifold	C 124.05
–	x	x	Remove exhaust turbocharger	C 101.01
–	x	x	Remove exhaust manifold	C 142.05
–	x	x	Remove crankcase ventilation (if necessary)	C 018.10
–	x	x	Remove cylinder head cover	C 055.10
–	x	x	Remove H.P. fuel line	C 073.05
–	x	x	Disconnect leak-off fuel lines	C 086.05
–	x	x	Remove rocker arm assembly	C 055.05
–	x	x	Remove pushrods	C 054.05

C 041.05.05 Removal

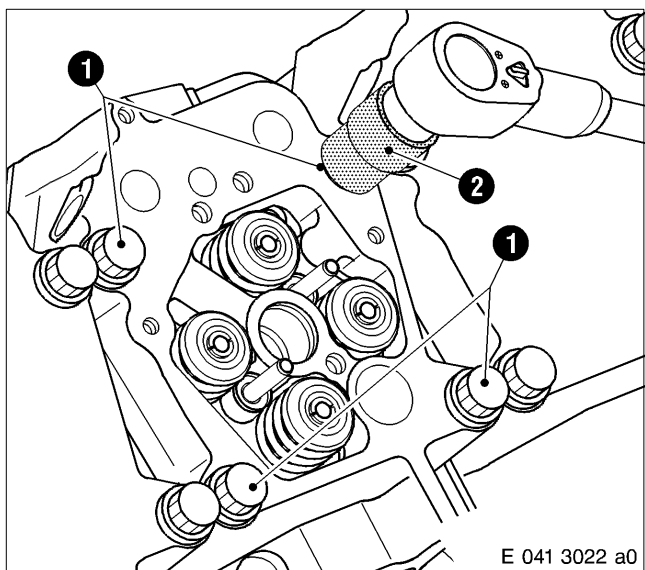

Removing cylinder head

Evenly remove double-hex screws (1) for cylinder head with large ratchet and socket (2).

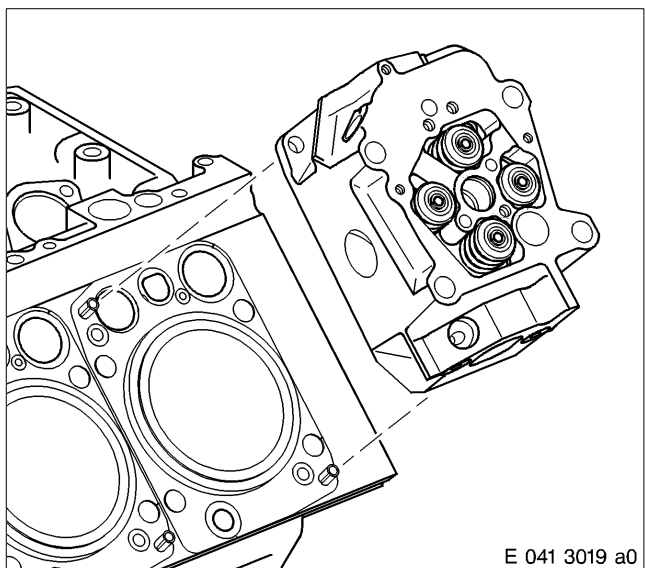

CAUTION

**Components have sharp edges.
Risk of injury.
Touch components only when wearing protective gloves.**

Lift cylinder head from crankcase and lower onto suitable support.

Note: With injector installed, place cylinder head to the side. Injector protrudes at bottom of cylinder head.

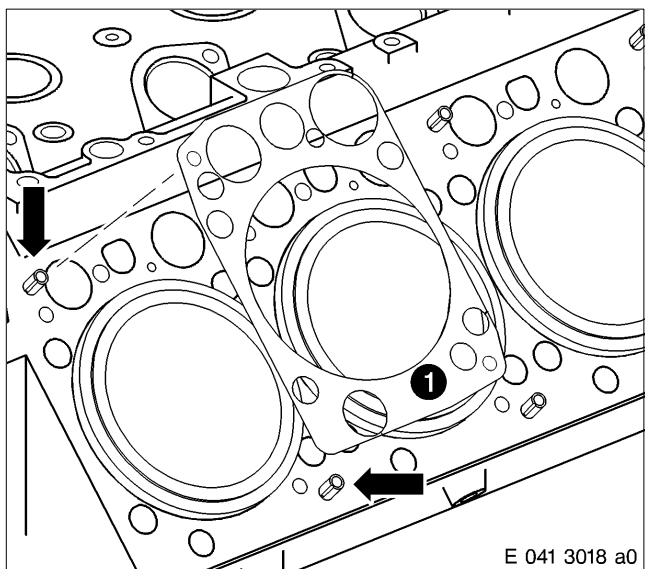

Remove cylinder head (1)

Using a suitable blanking plug, seal oil bores and coolant bores in crankcase.

If necessary (e.g. due to damage), remove spring pins (arrows) from crankcase.

C 041.05.06 Disassembly

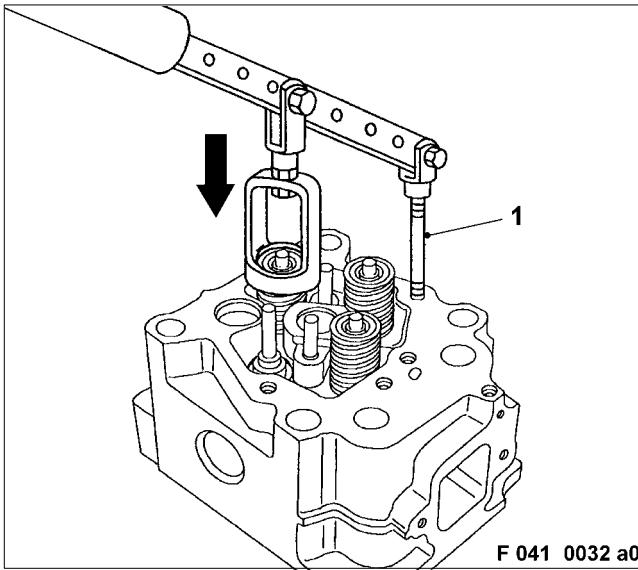

F 041 0032 a0

Removing valves

Fit cylinder head on cylinder head interface and tighten.

Insert stud (1) of valve lift into threaded bore in cylinder head.

CAUTION
<p>Spring pretension. Risk of injury. Only use specified tool.</p>

Press down valve spring retainer with valve lift (arrow).

At the same time, hold the valve firmly in position against the valve head.

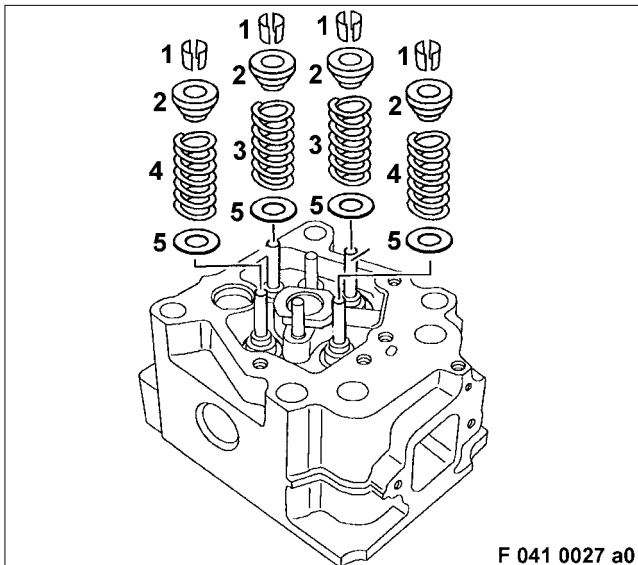

F 041 0027 a0

Using bar magnet, lift out valve collets (1).

Release valve spring.

After removing all valve collets, remove valve lift.

Remove valve spring retainer (2).

Remove valve spring inlet (3) and outlet (4).

Using bar magnet, lift out valve spring seat (5).

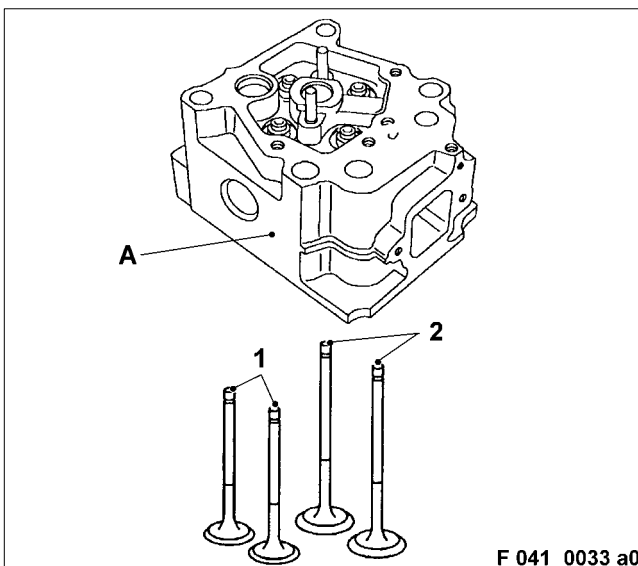

F 041 0033 a0

Lay cylinder head on its side.

Mark exhaust valve (1) and inlet valve (2) according to their installation position.

Remove valves from valve guides.

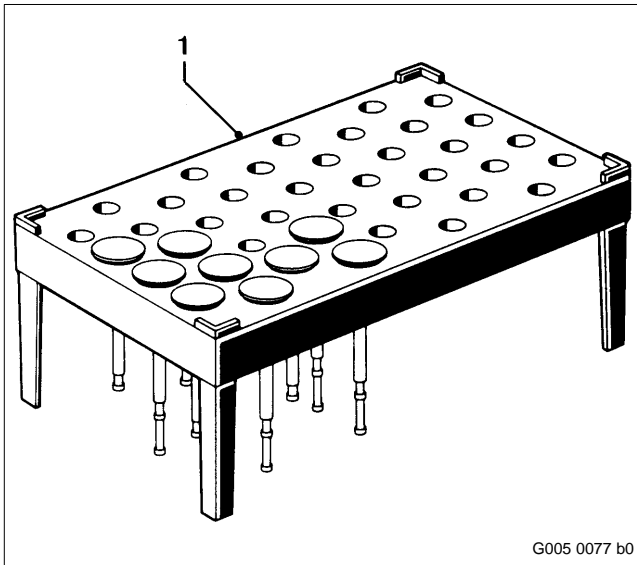

Place valves in storage frame (1) to protect them from damage.

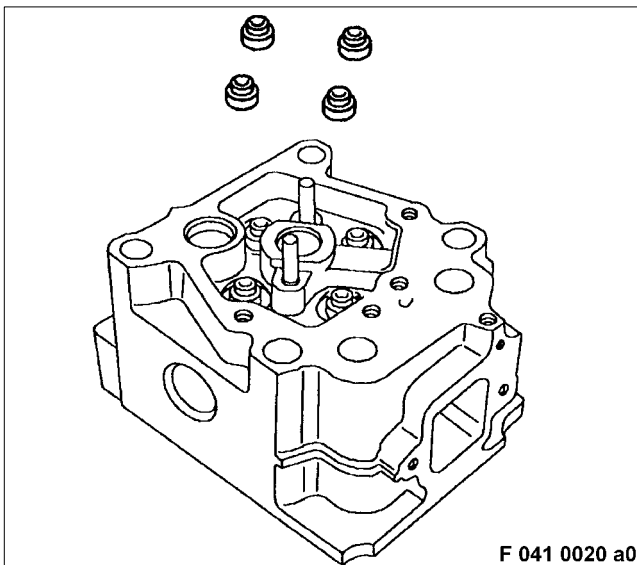

Removing valve shaft gaskets

Fit cylinder head on cylinder head interface.
Press-off valve shaft gaskets with two screwdrivers from valve guides; take care not to damage valve guide.

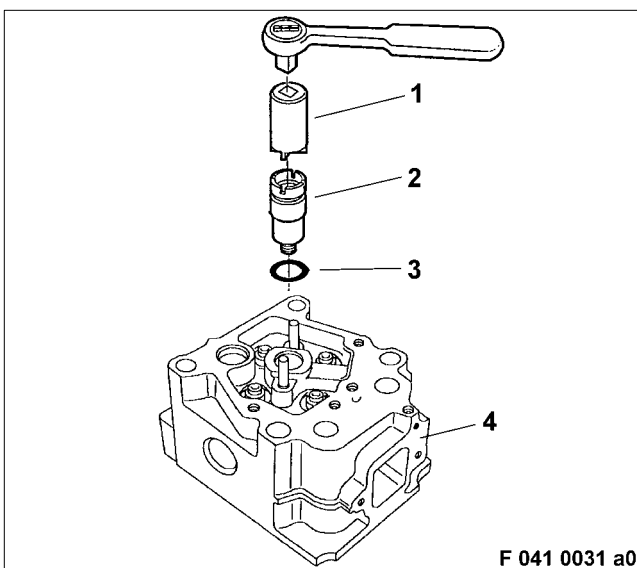

Removing protective sleeve

Secure cylinder head firmly in position.
Use socket wrench (1) to unscrew protective sleeve (2) from cylinder head.

Note: Make sure that socket is correctly engaged in sleeve groove.

Remove O-ring (3) from cylinder head.

C 041.05.08 Inspection and Repair

Clean all components with cold cleaner.



CAUTION

When using these chemical substances, it is essential to observe the Manufacturer's Instructions for use, safety instructions and waste disposal specifications.

If necessary, pretreat oil-carbon deposits on valves and cylinder heads with carbon-deposit remover.

After cleaning with carbon-deposit remover, rinse components in water until no further residues are washed off.

Check cylinder head interfaces (combustion chamber side) for evenness and damage and porous areas; recondition as necessary.

Using red penetrant dye method, crack-test cylinder head mating face and valve seats; replace components as necessary.

If cracks are found in the cylinder head mating face, it can be reconditioned up to the wear limit.

Surface quality (roughness height, shaft height) of cylinder head interfaces must be maintained.

Material removal must not be below minimum permissible height (cylinder head total height).

For instructions on machining and limit values – see Tolerances and Wear Limits List.

After reconditioning, repeat the crack test.

If there is still evidence of cracks, replace cylinder head.

If cracks are found in the valve seat inserts, then they must be replaced.

Check mating face of protective sleeve in cylinder head for scoring and wear; rub down if within tolerance.

See Tolerances and Wear Limits List.

Check thread of protective sleeve in cylinder head for ease of movement and wear, recondition as necessary.

Check valve spring seats and wedges for wear; replace as necessary.

Check all threads in cylinder head for ease of movement; rechase threads as necessary.

Replace cylinder head gaskets and O-rings.

Replace valve shaft gaskets as part of W6 major overhaul.

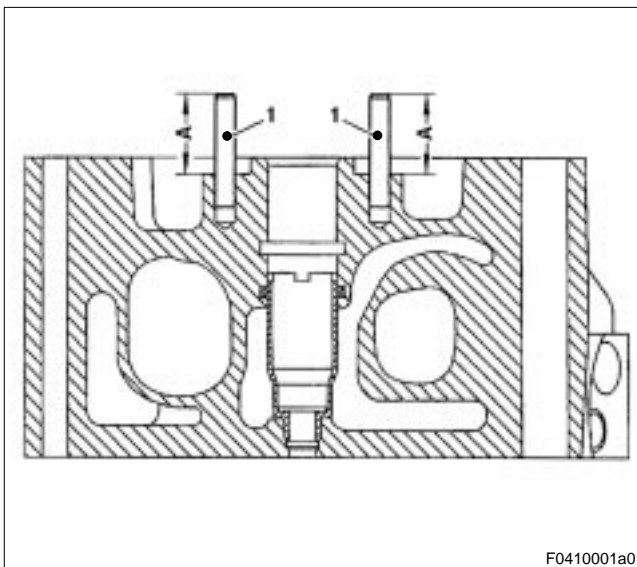

Checking pin

Check pin (1) for damage and wear; replace as necessary.

Measure outside diameter of pin with micrometer.

If limit value is not achieved, (see Tolerances and Wear Limits List), replace pin as necessary.

Measure protrusion A of pin.

A = 36.5 mm

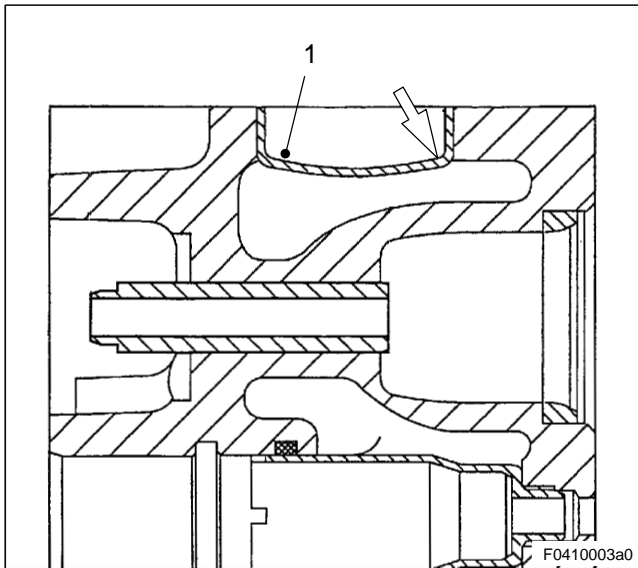

Replacing end cover

Note: Remove end cover only if necessary (e.g. in event of leakages).

Using punch, carefully tap cover (1) into bore at one side (arrow) until it tilts. Use pliers to remove cover from bore. Then withdraw cover with pliers.

When removing, take great care that cover does not fall into bore and that sealing face of bore is not damaged.

Note: Never drill cover as metal chips in coolant jacket of cylinder head can cause localized overheating.

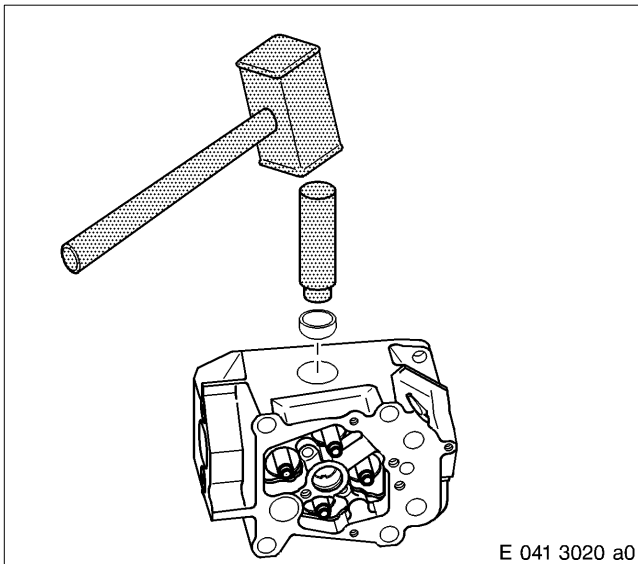

Clean and degrease seating face on new end cover and cylinder head bore.

Coat seating face of cylinder head bore with thread-locking agent.

Using a mandrel, insert end cover flush with bore in cylinder head.

Note: Ensure correct final strength of thread-locking agent – see C 040!

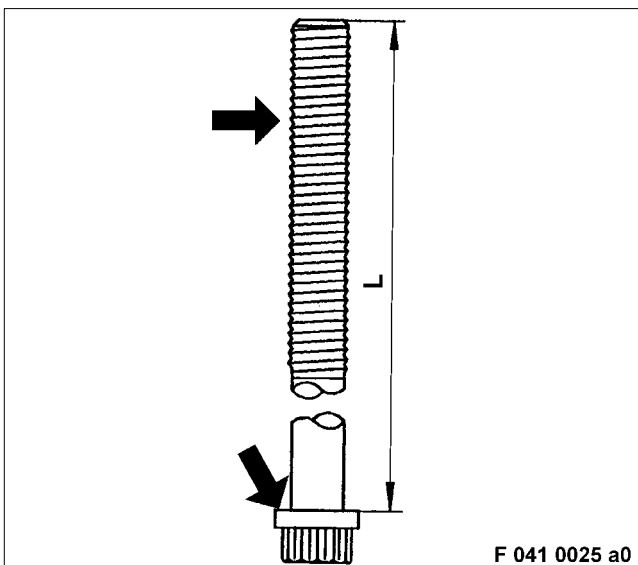

Checking cylinder head bolts

Check screw head support and thread (arrows) for scoring or damage; replace screw if necessary.

Measure shaft length with depth gauge.

For max. permissible shaft length – see C 041.05.01.

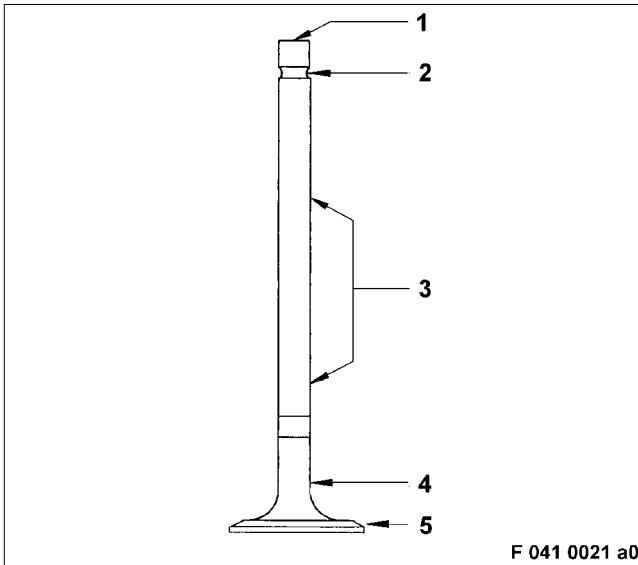

Checking valves

Check valves for damage, pitting, scoring and indentations on pressure surface (1), valve keyway (2), shaft (3) neck (4) and plate (5).

If chrome plating is damaged or worn through, if indentations or scoring is found on valve stem or pitting at transition from valve head to valve stem, replace valves.

Valve keyways must not be damaged and valve seats must not be burnt.

Check valves for concentricity and dimensional accuracy.

Regrind valve seat on a valve grinding machine to compensate minor deviations in the concentricity or replace valve.

Note: Do not straighten valves!

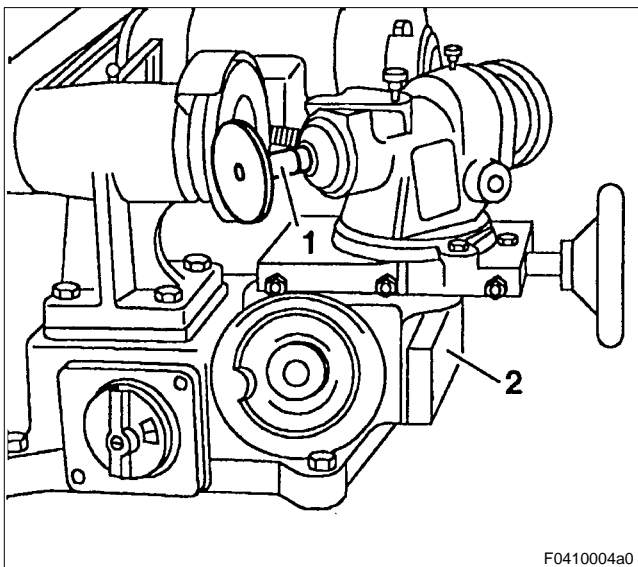

Regrinding valve seats

Note: Do not remove more material than is absolutely necessary to achieve perfect valve seating.

Clamp valve (1) in valve grinding machine (2) as close as possible behind the valve head (to prevent vibrations).

Set valve seat grinding angle on valve seat grinding machine.

Grind valve seat with slight advance until valve seat is smooth and free from chatter marks over the entire circumference.

Measure height of external edge on valve seat and valve seat width.

If limit values as per Tolerances and Wear Limits List are exceeded, replace valve.

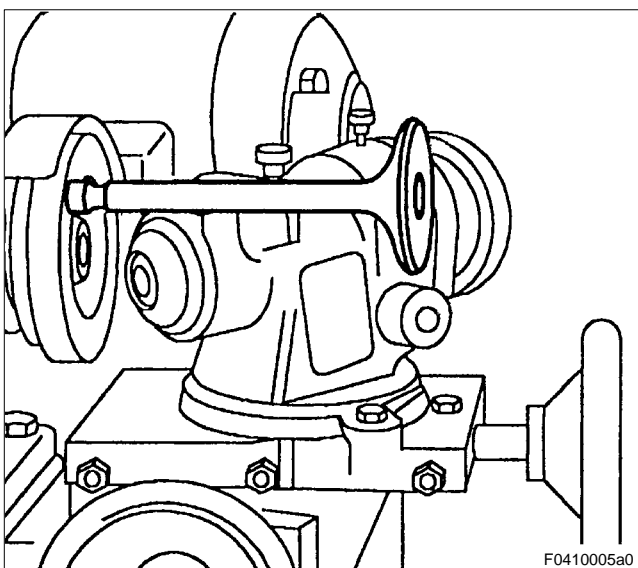

If necessary, recondition valve shaft end on device provided on valve grinding machine.

Measure valve length; if limit value is not achieved, (see Tolerances and Wear Limits List), replace components as necessary.

Using the surface crack-testing method with fluorescent penetrant dye, check valves for cracks; replace if necessary.

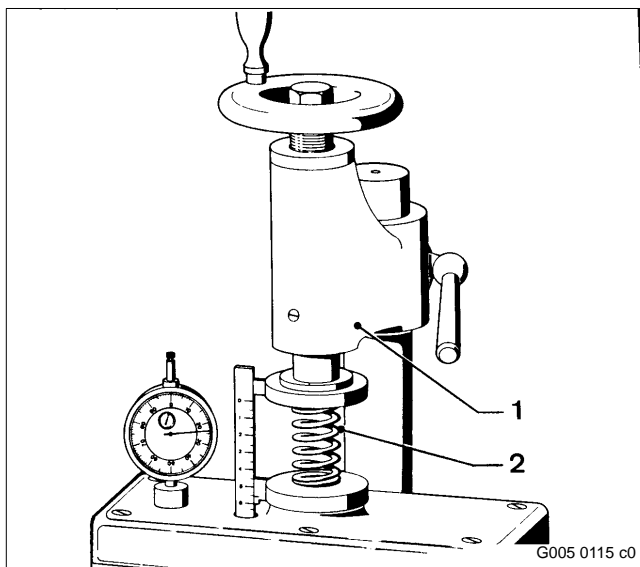

Checking valve springs

Check valve spring (2) with valve spring tester (1).
If limit values as per Tolerances and Wear Limits List are exceeded, replace valve spring.
Check valve springs for indentations, flatness, burring and deformation and replace if necessary.

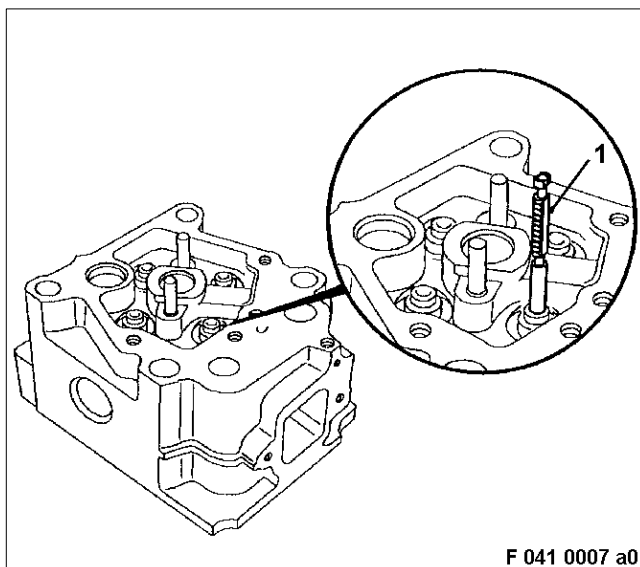

Checking valve guides

Clean bores of valve guides with valve guide cleaning brush.
Check all valve guides for wear and damage; replace components as necessary.
Check valve guides with plug gauge (1) for wear.
If side of plug gauge marked with "+" is able to pass through valve guide, replace valve guide .

Replace valve guides

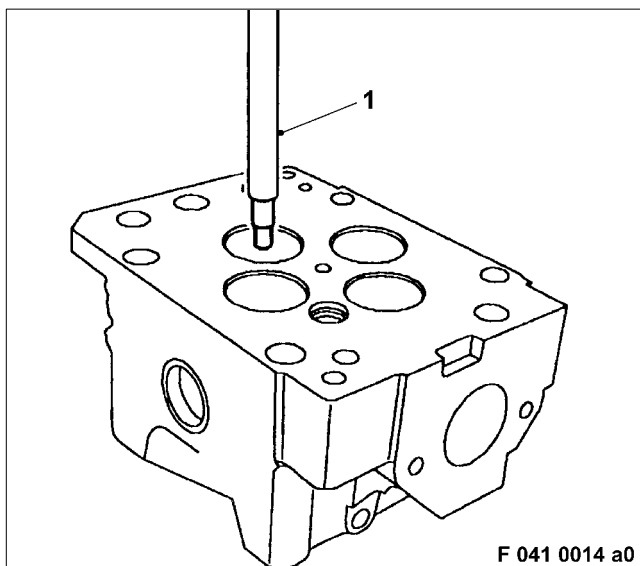

Removing valve guides

Place cylinder head on hydraulic press.
Make sure that mating face for valve gear housing is seated correctly.
From the combustion side, press valve guide out of cylinder head with removal mandrel (1).

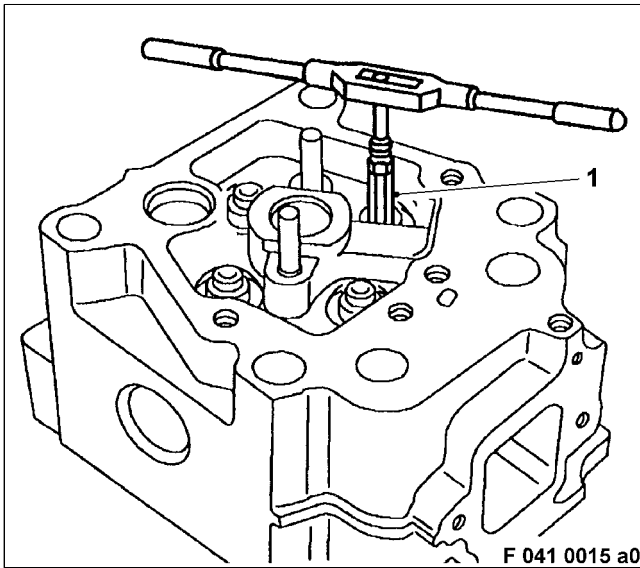

Checking and reconditioning valve guide bore diameter in cylinder head

Using a bore gauge, measure valve guide diameter (A), see C 041.05.01 – Arrangement of valve guides in cylinder head.

For limit values, see Tolerances and Wear Limits List.

If the values deviate from the test values, the main bores must be reconditioned to the next stage.

Using a reamer (1), recondition the valve guide bore in the cylinder head to the next biggest stage.

Turn reamer only in a clockwise direction.

Check alignment of valve guide to cylinder head as per Tolerance and Wear Limits List.

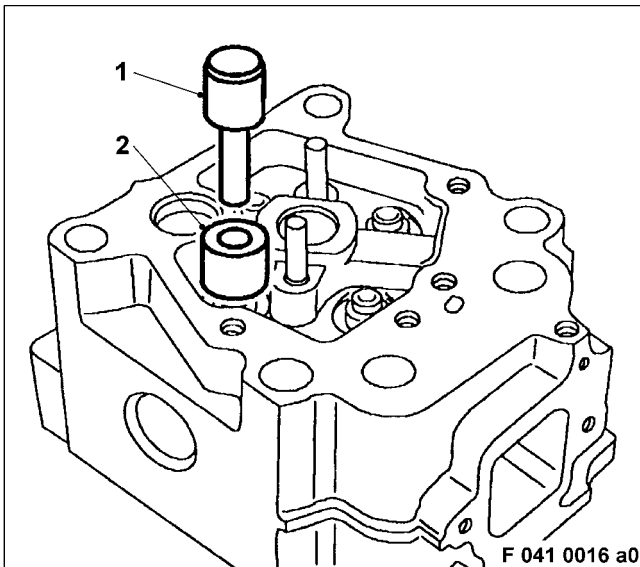

Installing valve guides

Cool the valve guides in liquid nitrogen for approx. 20 to 30 min.

CAUTION

Nitrogen is liquid at $-200\text{ }^{\circ}\text{C}$ ($-328\text{ }^{\circ}\text{F}$) Danger of freezing and suffocation!

Do not allow liquid nitrogen to come into contact with parts of body (eyes, hands).

Wear protective clothing (including gloves and closed shoes) and goggles.

Ventilate working area well.

Using a mandrel (1) and spacer bush (2), press-fit the cooled valve guide in bore in the cylinder head.

Measure distance (D) from the upper edge of the valve guide to the mating face of the valve springs, see C041.05.01 – Arrangement of valve guides in the cylinder head.

For specified distance, see Tolerances and Wear Limits List.

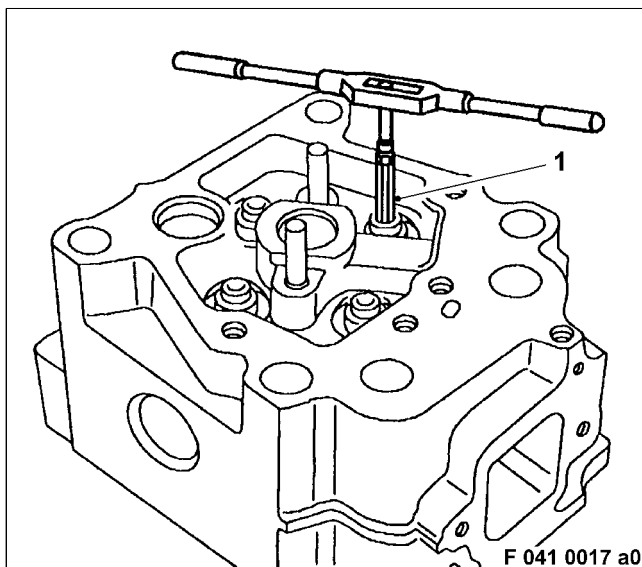

Using a reamer (1), recondition the valve guide bore to a bore diameter of 8.95 mm.
Turn reamer only in a clockwise direction.

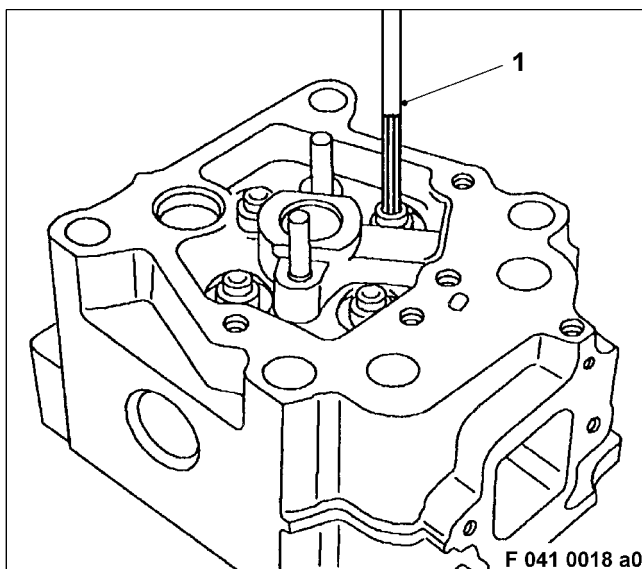

Using a reamer (1), recondition valve guide bore to finished dimension (B), see C 041.05.01 – Arrangement of valve guides in cylinder head.
Turn reamer only in a clockwise direction.
For dimensions and limit values, see Tolerances and Wear Limits List.

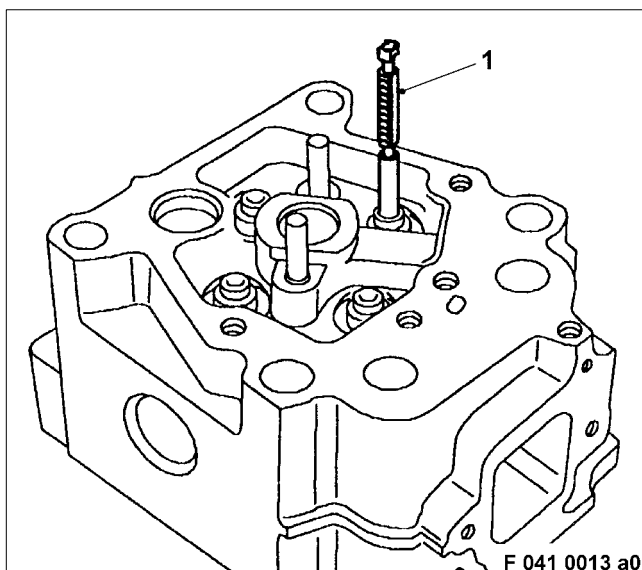

Clean bores of valve guides with valve guide cleaning brush.
Check valve guides with plug gauge (1).
"GO" side of plug gauge must slide through valve guide with only slight resistance.
"NO-GO" side of plug gauge (side marked with "+") must not be in contact; otherwise replace valve guide.

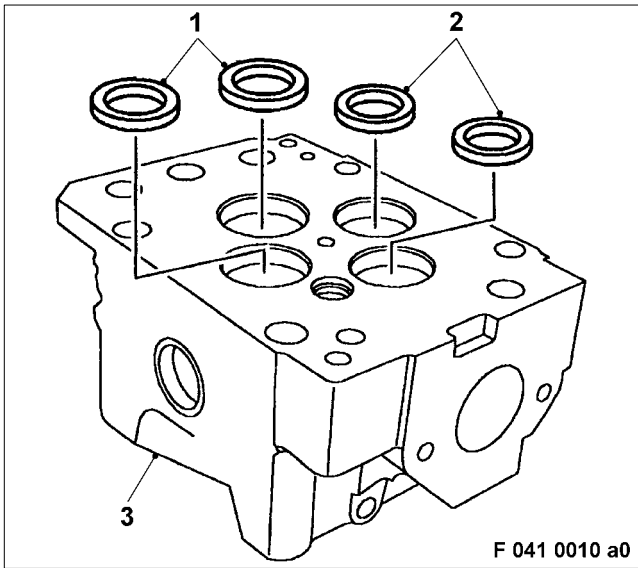

F 041 0010 a0

Checking valve seat inserts

Check valve seat insert - outlet (1) and valve seat insert – inlet (2) for cracks and visually check condition; recondition and replace as required.

Recondition seats

- after extended periods of operation
- if findings are negative, e.g. damaged seat surfaces, deep pitting, uneven valve seat/valve taper bedding pattern.

- after installation of new valve seat inserts

Replace seats if

- there are cracks in the seat surface
- if areas are burnt through
- the reconditioning wear limit has been exceeded

Valve seat insert reconditioning

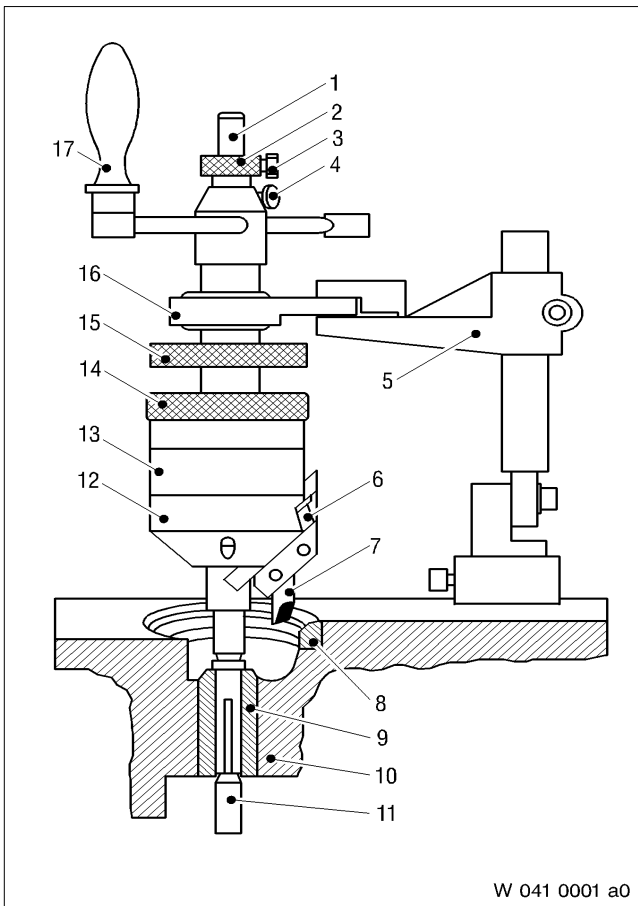

W 041 0001 a0

Valve seat rotator arrangement

- 1 Stop pin
- 2 Knurled-head screw
- 3 Locking screw for stop pin
- 4 Locking screw for knurled-head screw
- 5 Steady rest
- 6 Tool slide
- 7 Lathe tool
- 8 Valve seat insert
- 9 Valve guide
- 10 Cylinder head
- 11 Tap pilot
- 12 Machining head
- 13 Gearbox housing
- 14 Rapid adjuster
- 15 Advance rotator
- 16 Cone pin
- 17 Crank handle

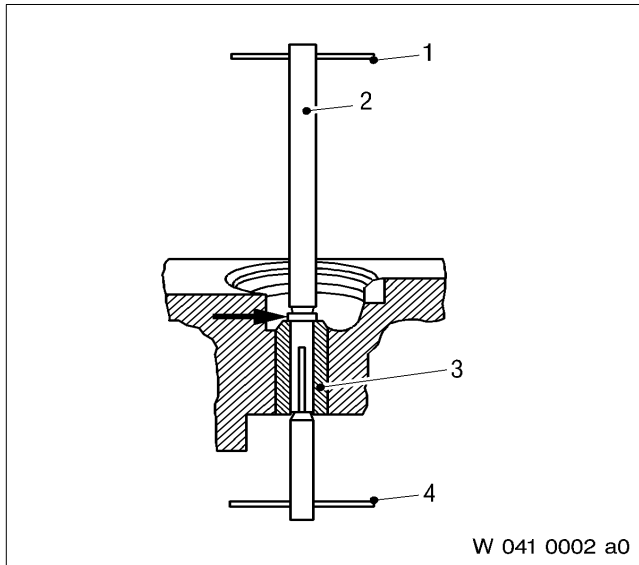

Valve seat insert reconditioning

Note: Valve guides are installed and machined to finished dimension. Machine valve seats at inlet and outlet valve seat insert.

Clamp cylinder head so that valve guide (3) is in vertical position, taking into account tap pilot protrusion (2) to bottom.

Insert suitable tap pilots into clean valve guide.

Clamp collar (arrow) must rest on valve guide at top. Insert rotating pins (1) and (4) and turn in clockwise direction to tighten tap pilots with moderate force until tap pilot is securely seated. Hold at bottom, turn top only.

To remove, hold at bottom and turn top. If pins are stubborn tap pilot lightly and remove pins.

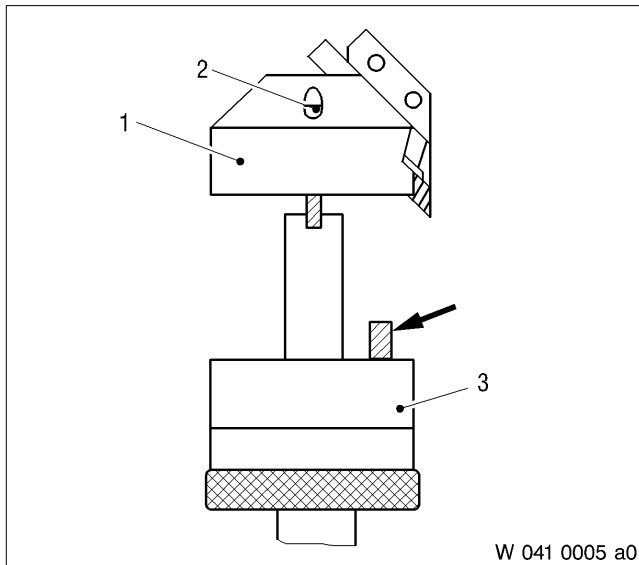

Select required machining head (1):

30° – Machining head for inlet seat

45° – Machining head for outlet seat

Mount machining head on gearbox housing (3) so that the toothed pinion (arrow) engages in orifice provided in machining head.

The machining head must be seated flush with gearbox housing.

Insert screws (2) loosely so that machining head can still be moved to adjust clearance (see next illustration), between rack and toothed pinion.

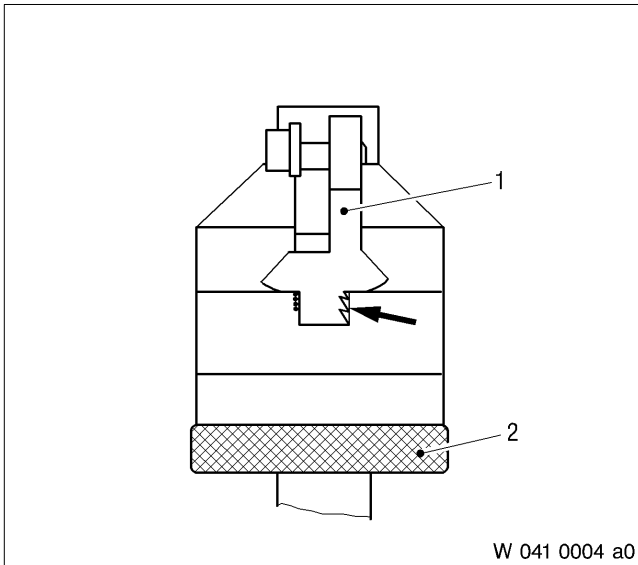

Align machining head so that distance between toothed side (arrow) of the rack and the opposite side of recess in gearbox housing is between 0.5 mm and 0.8 mm.

Then tighten both screws.

Move the tool slide (1) backwards and forwards with the rapid adjuster (2).

If the tool slide does not move relatively easily, release both screws and reset.

W 041 0004 a0

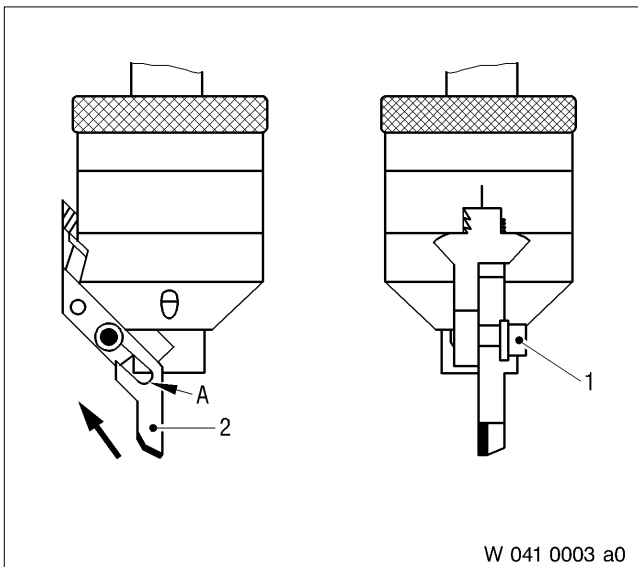

Fit suitable lathe tool (2) on shaft of clamping screw (1) (arrow), until basic surface (A) of lathe tool slit makes contact with screw shaft.

Secure lathe tool by tightening clamping screw.

W 041 0003 a0

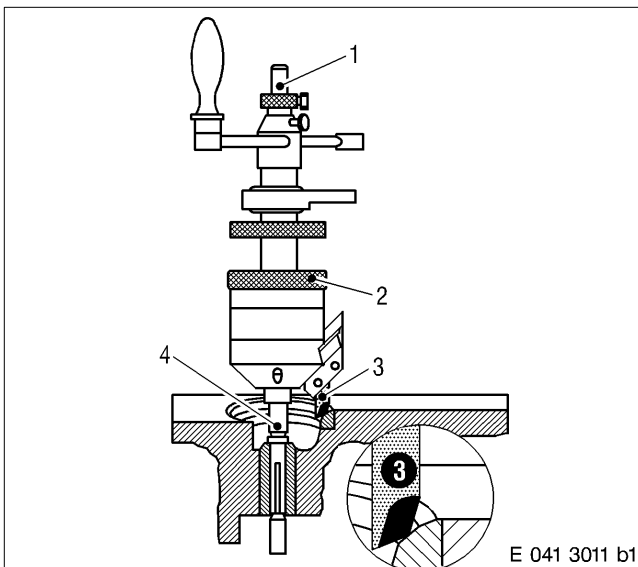

Carefully fit rotator on tap pilots (4) coated with oil until either the stop pin (1) contacts the pilots or the lathe tool (3) contacts the cylinder head.

Note: Avoid hard impact, hard metal chips easily.

Turn rapid adjuster (2) to position cutter at center of valve seat, while slightly raising head of tool.

E 041 3011 b1

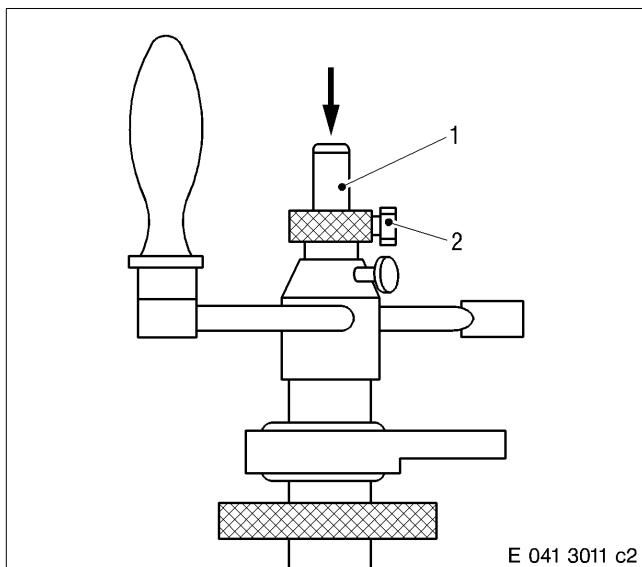

Hold rotator secure with one hand and release locking screw (2) of stop pin (1).
Carefully lower rotator until the top of lathe tool contacts the valve seat.
Gently press stop pin down (arrow) against the tap pilots and tighten locking screw.

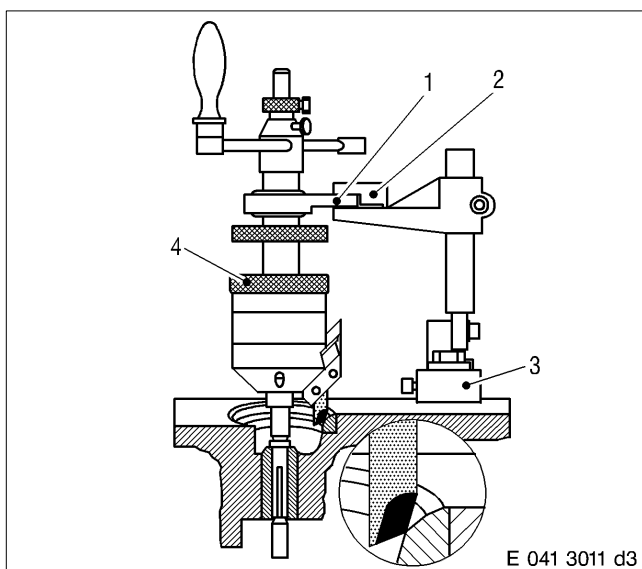

Using a suitable screw, secure base (3) of steady rest to cylinder head sealing surface.
Clamp cone pin (1) horizontally approx. in centre of pin with steady rest pliers (2).
Rotator must now turn just as easily as before.
If this does not occur, release clamp on steady rest and reclamp until the rotator can be easily turned.
Slightly raise rotator and turn rapid-adjuster (4) to bring turning tool (4) into contact with inner edge of valve seat.

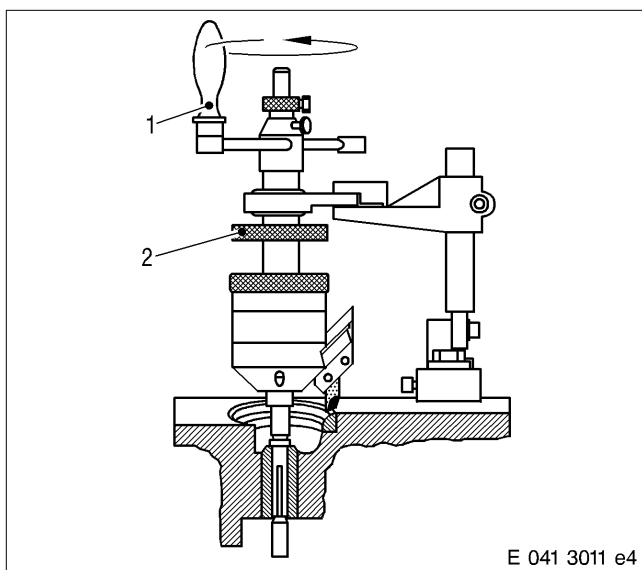

Hold advance actuator (2) and turn crank (1) evenly in clockwise direction (arrow).
Usually irregular material removed is apparent here.
After releasing, slightly raise rotator head and use the rapid adjuster to move the turning tool inwards.

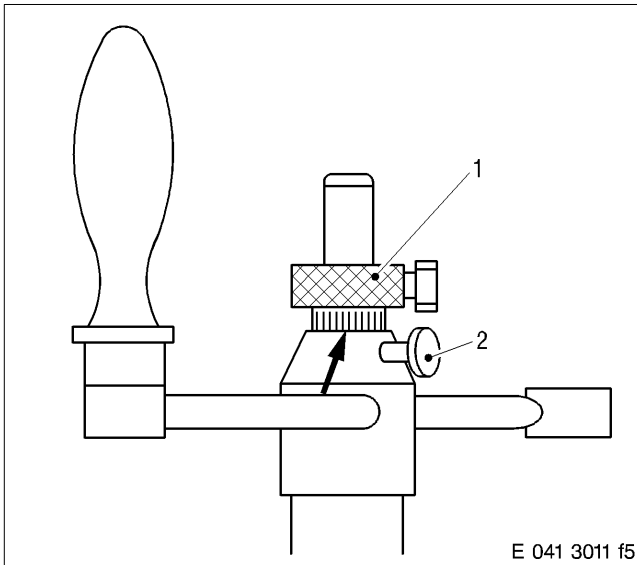

Release locking screw (2) and turn knurled screw (1) approximately 1 gradation = 0.1 mm (see arrow) counterclockwise.

Tighten locking screw.

Repeat machining process.

Repeat adjustment for cutting until valve seat face exhibits uniform surface.

Perform final machining run without readjusting cutters.

Observe machining limits – see Tolerances and Wear Limits List.

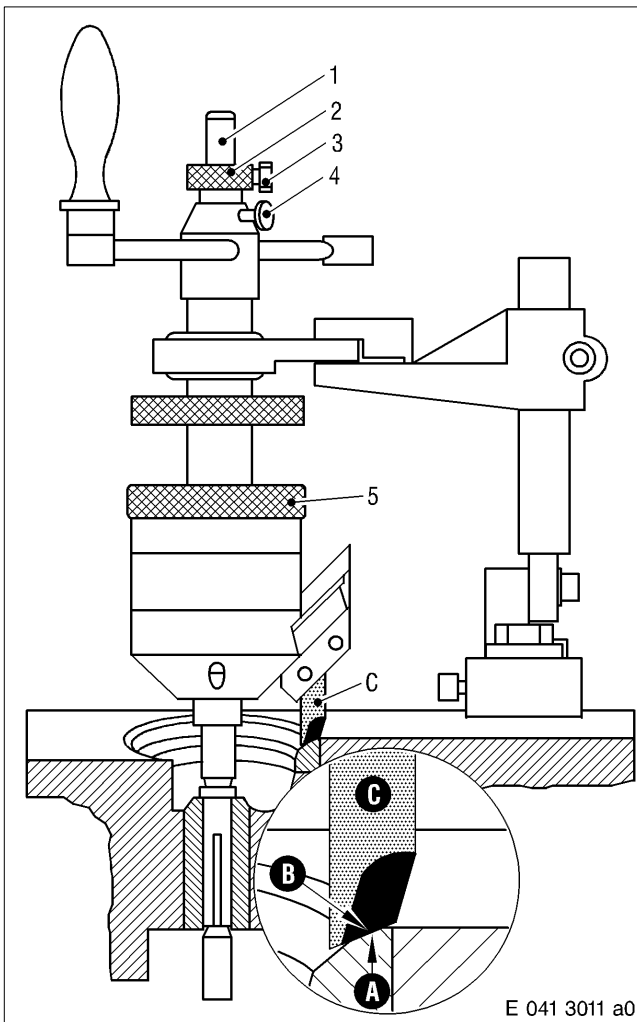

Externally correcting valve seat

Raise rotator and release locking screw (3) of stop pin (1).

Turn rapid adjuster (5) to bring trail edge (B) of turning tool (C) into contact with the outer edge (A) of the valve seat.

Note: Carefully lower rotator onto valve seat edge!

Gently press stop pin down against the tap pilot and tighten locking screw.

Release locking screw (4) and turn knurled screw (2) approximately 1/2 gradation counterclockwise. Retighten locking screw.

Hold rocker arm in one hand and the other rocker arm in the other hand and turn the rotator in stages around the tap pilots. Press the rotator slightly downwards until the outer edge (A) of the valve seat is adjusted to the set depths.

Repeat machining procedure until the required valve seat width is achieved.

For required valve seat width – see Tolerances and Wear Limits List.

Remove rotator

Do not remove tap pilot.

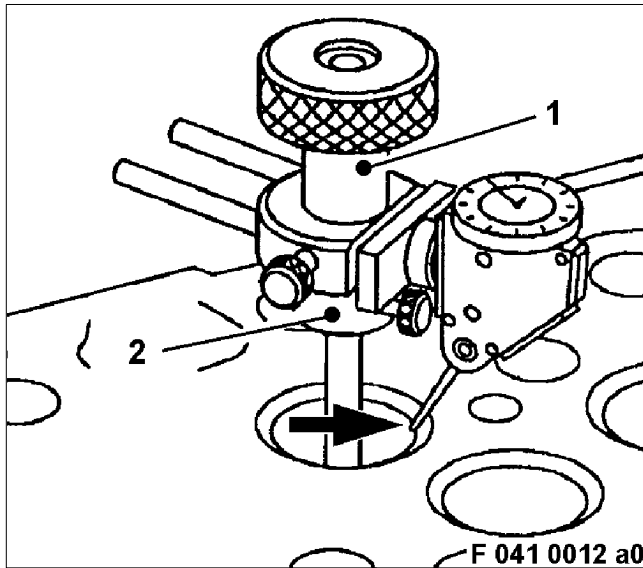

Checking concentricity of valve seat

Mount clamp ring (2) over the installed tap pilot and secure firmly in position.

Mount the testing device (1) on the clamp ring.

Set feeler of testing device with preload on valve seat centre (arrow).

Turn the testing device slowly around the tap pilot.

Check concentricity of valve seat in relation to valve guide.

For limit values – see Tolerances and Wear Limits List.

Recondition valve seat insert once again if there is any deviation from the test values.

Remove testing device, clamp ring and tap pilot.

Carefully clean cylinder head after machining.

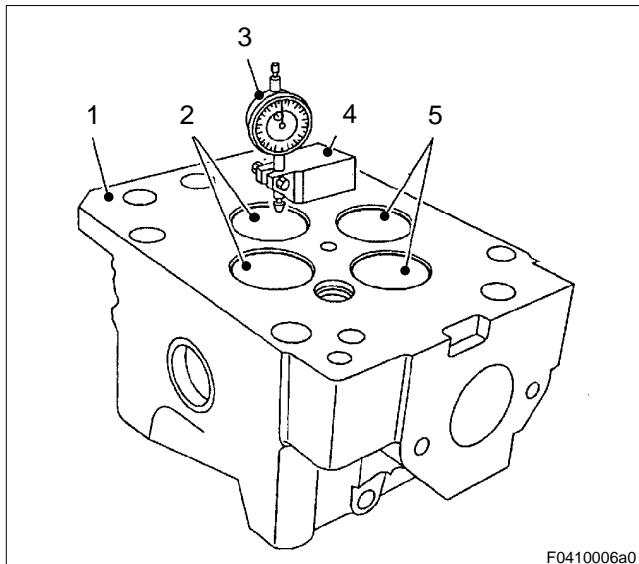

Measuring valve clearance to cylinder head

Note: Use new valves for measuring, or grind run-in valves before installation.

Insert inlet valves (2) and exhaust valves (5) according to marking in cylinder head (1).

Install dial gauge (3) on dial gauge holder (4).

Fit dial gauge with preload on end face of cylinder head.

Set dial gauge scale to "0" .

Set feeler on valve head and measure and take note of valve clearance to end face.

For limit values, see Tolerances and Wear Limits List.

If the recorded values are not within the permitted tolerances, check valve seat insert or valve head.

Replacing valve seat insert

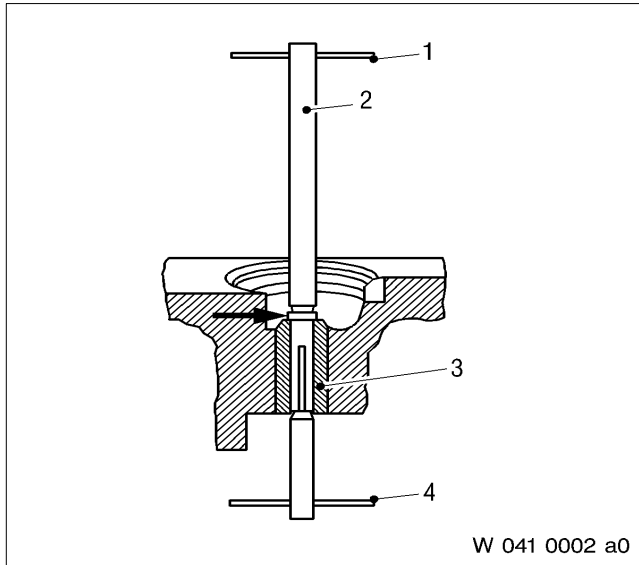

Removing valve seat insert from cylinder head.

Clamp cylinder head so that valve guide (3) is in vertical position, taking into account tap pilot protrusion (2) to bottom.

Insert suitable tap pilots into clean valve guide.

Clamp collar (arrow) must rest on valve guide at top. Insert rotating pins (1) and (4) and turn in clockwise direction to tighten tap pilots with moderate force until tap pilot is securely seated. Hold at bottom, turn top only.

To remove, hold at bottom and turn top. If pins are stubborn tap pilot lightly and remove pins.

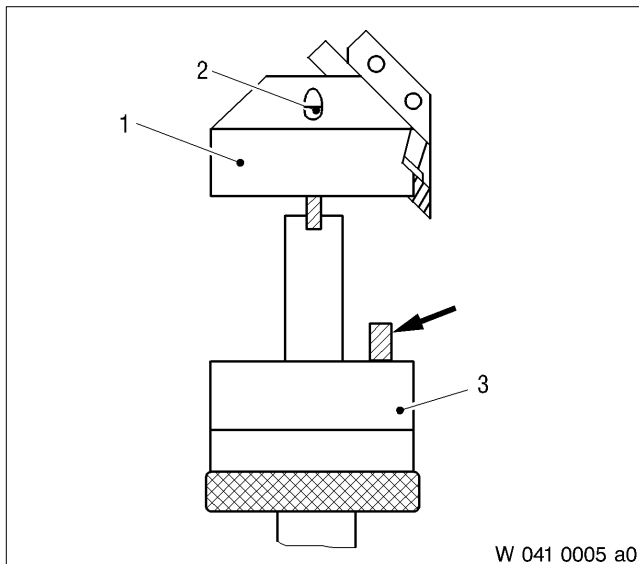

Mount 20° machining head (1) on gearbox housing (3) so that the toothed pinion (arrow) engages in orifice provided in machining head.

The machining head must be seated flush with gearbox housing.

Insert screws (2) loosely so that machining head can still be moved to adjust clearance (see next illustration), between rack and toothed pinion.

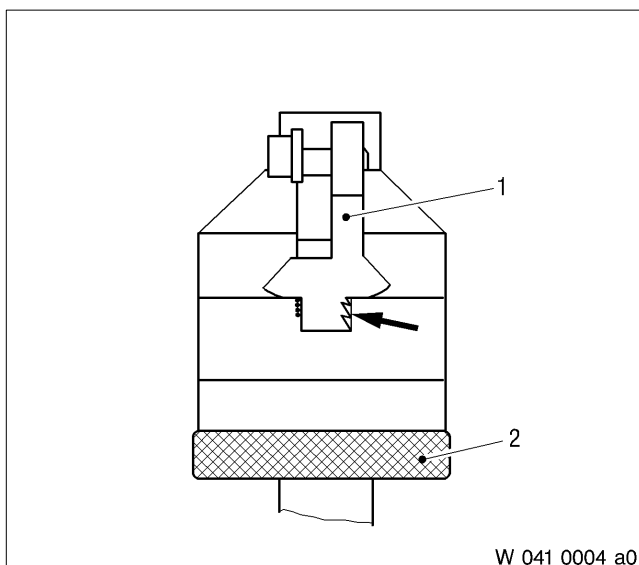

Align machining head so that distance between toothed side (arrow) of the rack and the opposite side of recess in gearbox housing is between 0.5 mm and 0.8 mm.

Then tighten both screws.

Move the tool slide (1) backwards and forwards with the rapid adjuster (2).

If the tool slide does not move relatively easily, release both screws and reset.

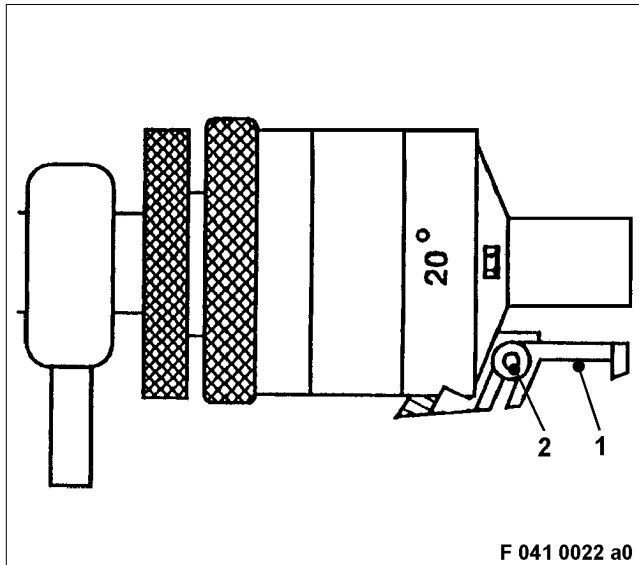

Fit lathe tool C6 (1) on shaft of clamping screw (2), until basic surface of lathe tool slit makes contact with screw shaft.

Secure lathe tool by tightening clamping screw.

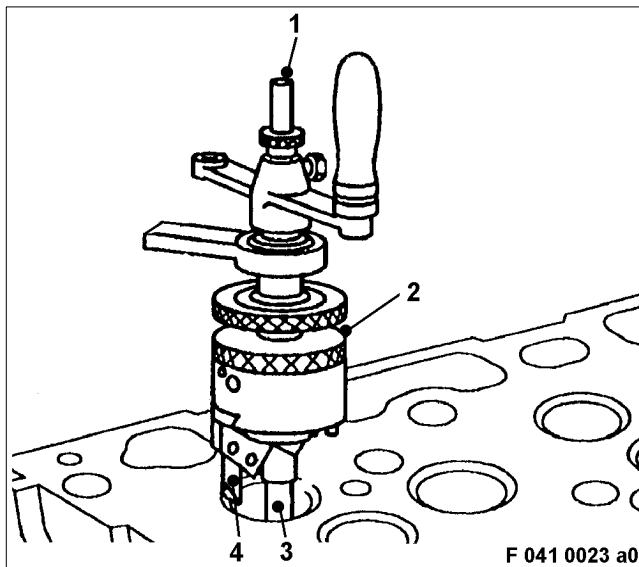

Carefully fit rotator on tap pilots (3) coated with oil until either the stop pin (1) contacts the pilots or the lathe tool (4) contacts the cylinder head.

Note: Avoid hard impact, hard metal chips easily.

Turn rapid adjuster (2) until lathe tool rests against tap pilot or is in front of valve seat insert (but not resting against it). Raise the rotating head slightly while doing this.

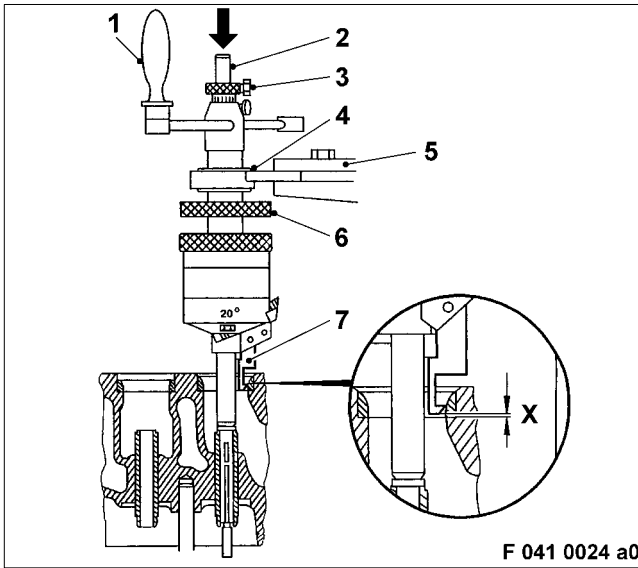

Hold rotator secure with one hand and release locking screw (3) of stop pin (2).
 Carefully lower the rotator until the tip of the lathe tool (7) is approx. 1 mm above the inside edge of the valve seat insert.
 Gently press stop pin down (arrow) against the tap pilots and tighten locking screw.
 Clamp cone pin (4) horizontally approx. in centre of pin with steady rest pliers (5).
 Rotator must now turn just as easily as before.
 If this does not occur, release clamp on steady rest and reclamp until the rotator can be easily turned.
 Hold advance actuator (6) and turn crank (1) evenly in clockwise direction.
 Usually irregular material removed is apparent here. Check dimension (X) approx. 1 mm at valve insert.

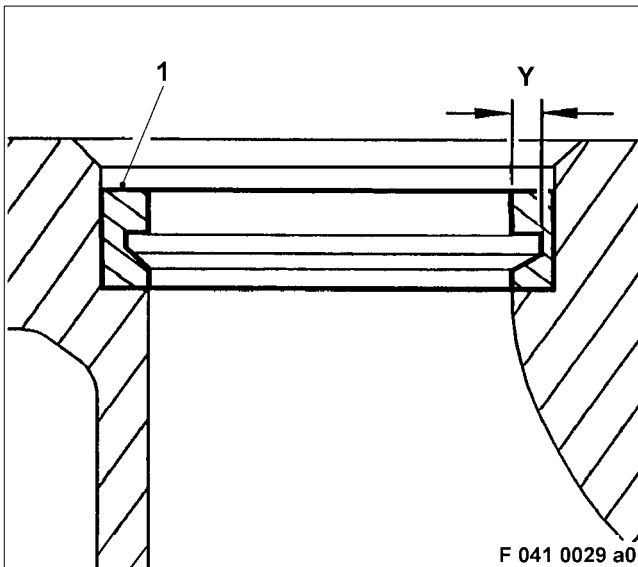

Turn crank evenly in clockwise direction while simultaneously holding advance actuator.
 In event of increasing turning resistance, briefly release advance actuator.
Note: Ensure that too much material is not removed. The rotating tool must turn as easily as before; this is achieved by briefly releasing the advance actuator.

Measure annular groove depth (Y) in valve seat insert (1).
 Required annular groove depth = from 2 mm to 3 mm
 Remove rotator and tap pilot.

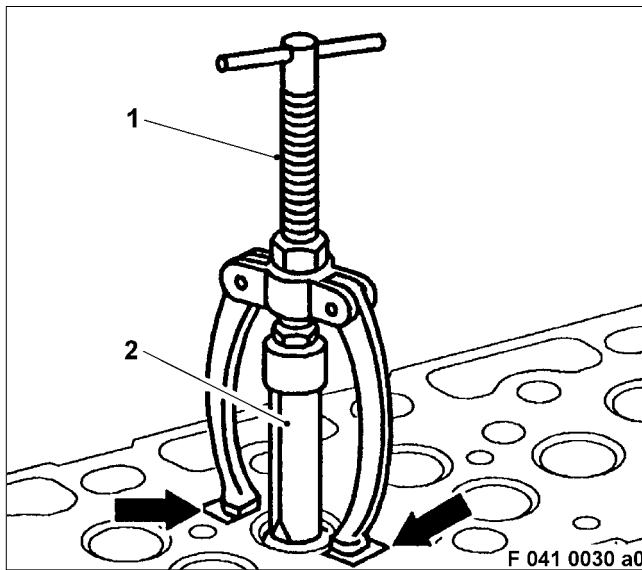

Fit internal extractor (2) for inlet valve seat insert or outlet valve seat insert in annular groove and remove valve seat insert with counter support (1). Place copper sheet under mating faces of counter supports (arrows) so that cylinder head surfaces cannot be damaged.

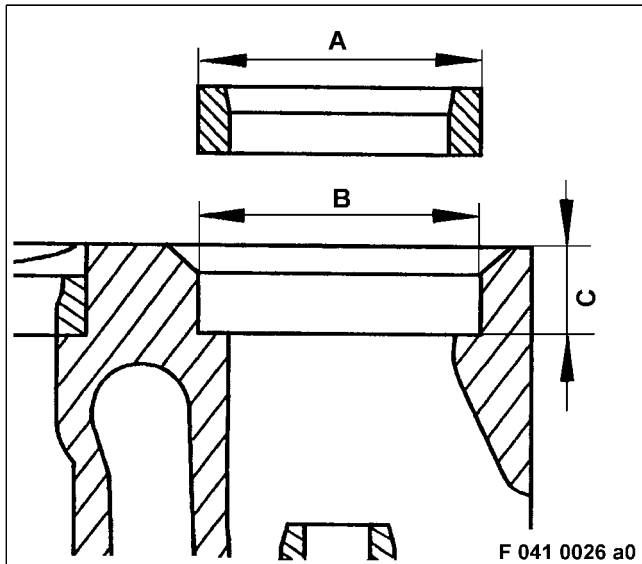

Checking main bore for valve seat insert in cylinder head, reconditioning if necessary

Measure valve seat insert bore diameter (B) with bore gauge.

Measure bore depth (C).

For limit values, see Tolerances and Wear Limits List.

If the values deviate from the test values, recondition the main bores on a boring mill to the next stage of valve seat insert diameter (A).

Check that the alignment between valve seat insert and main bore is in compliance with Tolerance and Wear Limits List.

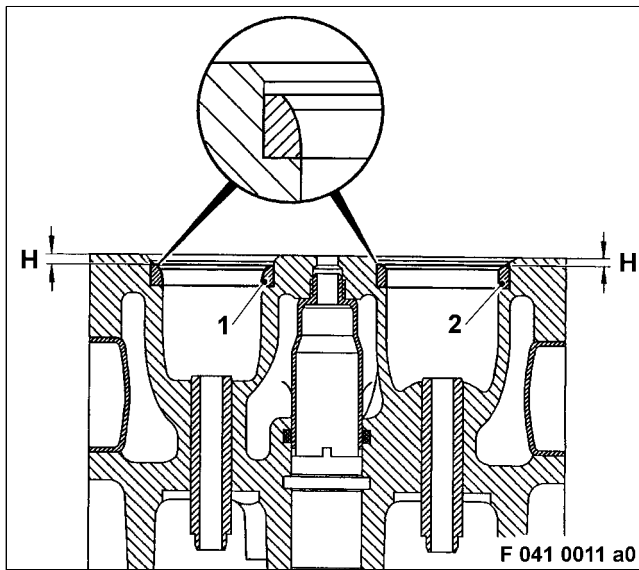

Installing valve seat inserts

Heat cylinder head to approx. 80°C in water bath.

CAUTION

**Component is hot.
Risk of injury!
Touch components only when wearing protective gloves.**

Cool valve seat inserts in liquid nitrogen for approx. 20 to 30 min.

CAUTION

**Nitrogen is liquid at - 200 °C (-328 °F) Danger of freezing and suffocation!
Do not allow liquid nitrogen to come into contact with parts of body (eyes, hands).
Wear protective clothing (including gloves and closed shoes) and goggles.
Ventilate working area well.**

Using a mandrel, press valve seat insert outlet valve (1) and/or valve seat insert inlet valve (2) into corresponding bore in cylinder head.

Note: The valve seat inserts must be press-fitted without delay!

Measure distance (H) between cylinder head partition and valve seat insert end face.

For limit values, see Tolerances and Wear Limits List.

Recondition valve seat inserts, see same Group.

Checking cylinder head for leaks

Carefully clean cylinder head after machining.

Note: The protective sleeve must be installed in order to test the coolant chambers for leaks.



WARNING

Compressed air is air which has been compressed under pressure. Risk of injury. Test pressure must not be exceeded. Always wear protective clothing, protective gloves and protective goggles/safety mask.

Pressure-test cylinder head with air in water bath for leaks.

Note: The water for pressure testing must be treated with anti-corrosive agent.

Coolant chamber: 2 bar air overpressure, permissible leak rate 10 cm³/min.

Fuel chamber: 2 bar air overpressure, permissible leak rate 3 cm³/min.

Air chambers (inlet and outlet ducts) and oil chambers are not inspected.

C 041.05.10 Assembly

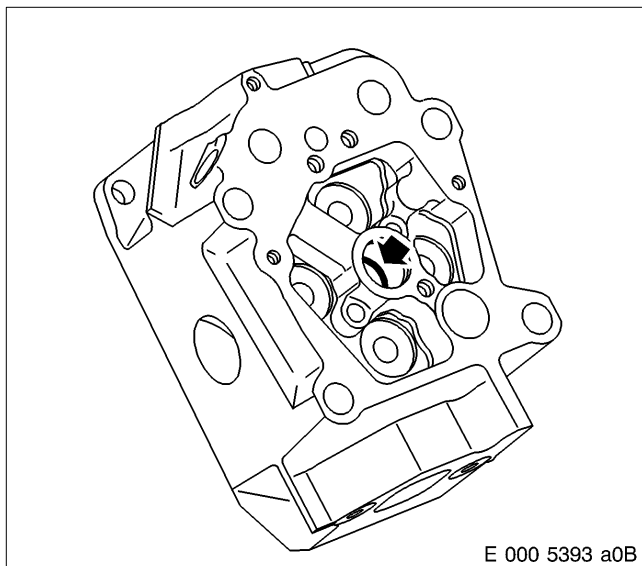

Installing protective sleeves

Clamp cylinder head in jig.

Check sealing face for protective sleeve and groove (arrow) for O-ring, clean if necessary.

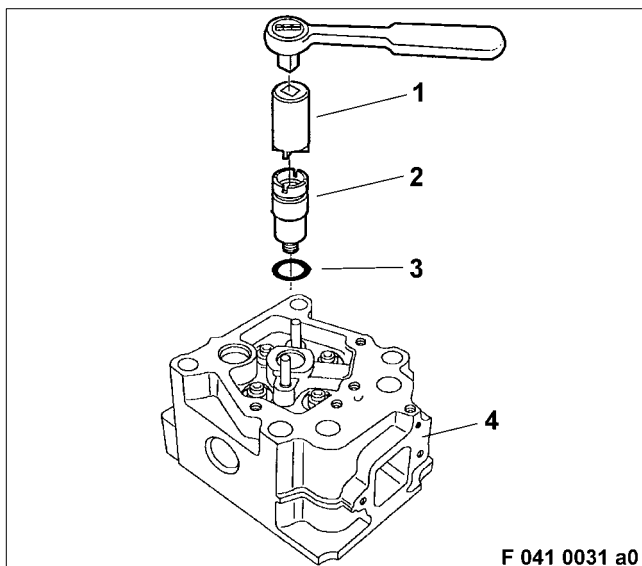

Check sealing surfaces on protective sleeve (2); clean if necessary.

Coat the new O-ring (3) with petroleum jelly and insert into groove in cylinder head (4).

Using socket (1), insert protective sleeve into cylinder head and tighten to specified tightening torque – see C 041.05.01.

Note: Make sure that socket is correctly engaged in sleeve groove.

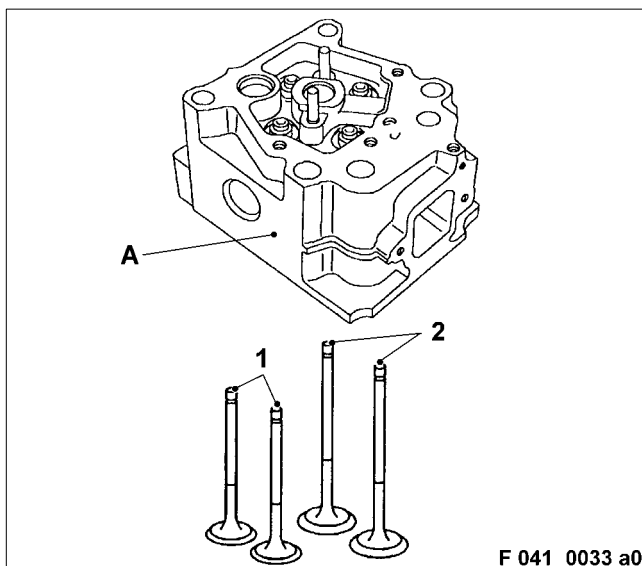

Installing valves, valves shaft gaskets and valve springs

Note: Make sure parts are perfectly clean.

Lay cylinder head on its side (A).

Wipe down exhaust valves (1) and inlet valves (2) with chamois leather and coat valve shafts with engine oil.

Insert valves in the corresponding valve guides in accordance with markings made prior to removal.

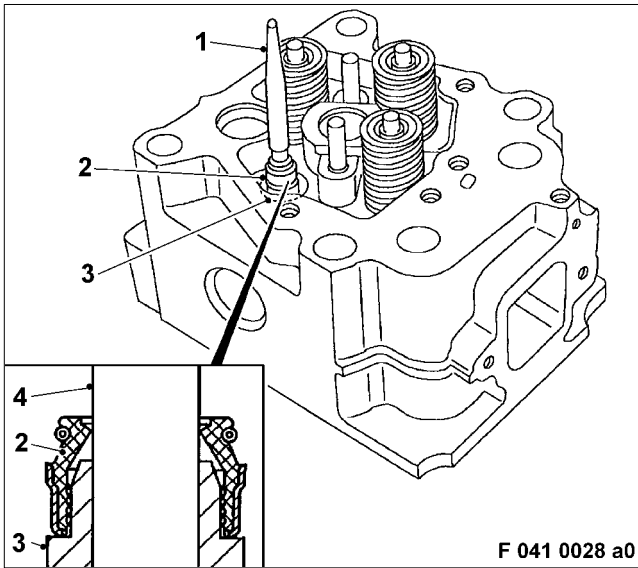

Fit cylinder head on cylinder head interface.
 Fit sleeve (1) over valve stem (4).
 Using a mandrel, manually press new valve stem gasket (2) over the sleeve onto the valve guide (3) to the stop.
 Check that valve stem gasket is fitted securely in valve guide collar.
 Remove sleeve.

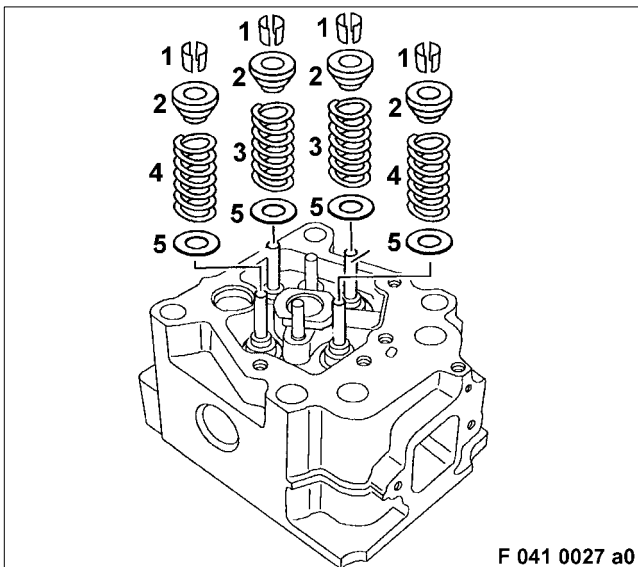

Mount valve spring seat (5) on every valve guide.
 Mount valve spring (inlet)(3) and valve spring (outlet)(4) on valve spring seat with the colour marking facing upwards.
 Place spring retainer (2) on valve spring.
 Install valve collet (1), see next illustration.

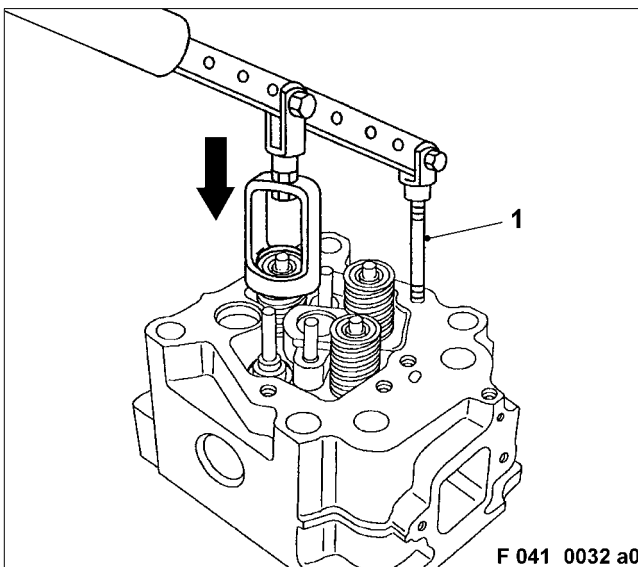

Clamp cylinder head in jig.
 Insert stud (1) of valve lift into threaded bore in cylinder head.

	CAUTION
<p>Spring preload. Risk of injury. Only use specified tool.</p>	

Press down valve spring retainer with valve lift (arrow).
 Insert valve collets into spring retainers and center.
 Make sure that lip of valve collets is securely seated in groove at end of stem.
 Release valve spring.
 Remove valve lift.

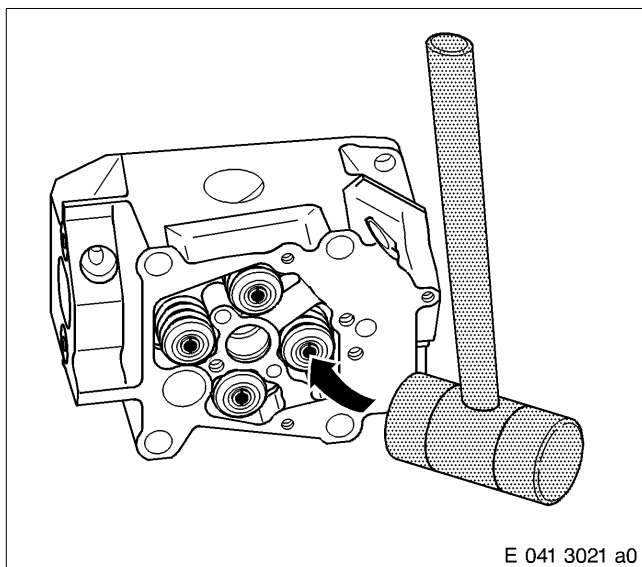

Lay cylinder head on its side.

Using a plastic mallet, lightly tap the valve stem so that valve collets are positioned correctly on the valve neck.

Measure valve clearance to cylinder head – see C 041.05.08.

If the recorded value is not within the permitted tolerances, see Tolerances and Wear Limits List, remove valves and check valve seat inserts and valve heads.

C 041.05.11 Installation

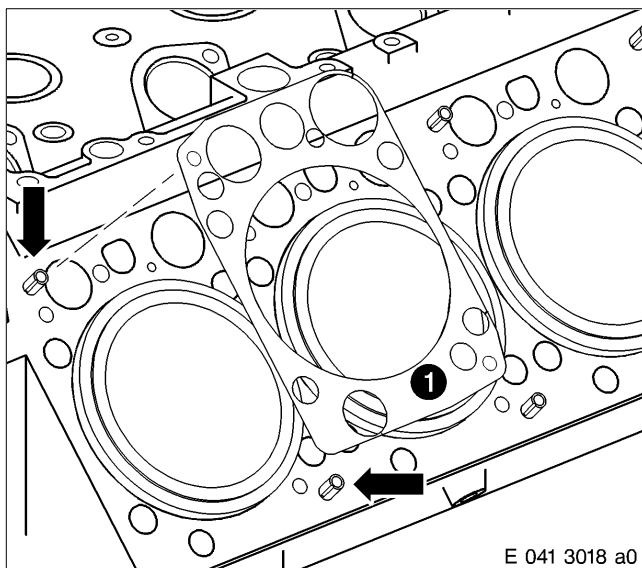

Installing cylinder head

Note: Prior to installation, remove all blanking plugs and check that oil bores are perfectly clean.

Wipe cylinder head and crankcase interface and check.

Insert new spring pins (arrows) into crankcase until they contact the stop.

Mount new cylinder head gasket (1) via spring pins on end face of crankcase as shown in illustration.

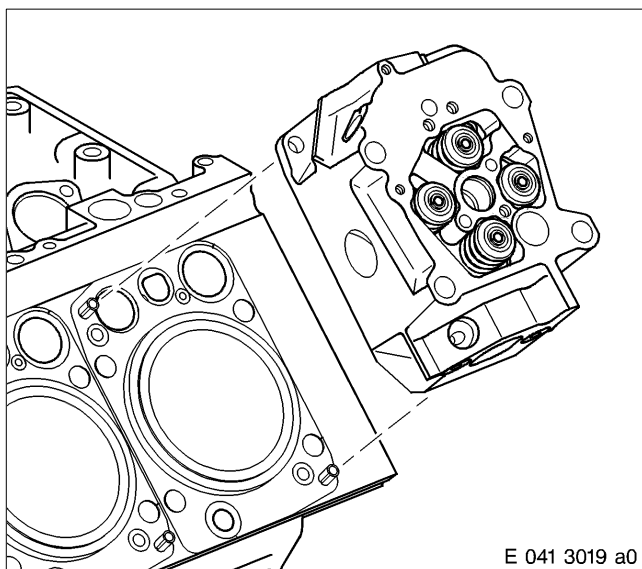

! CAUTION

**Components have sharp edges.
Risk of injury.
Touch components only when wearing protective gloves.**

Mount cylinder head via spring pins on cylinder head gasket.

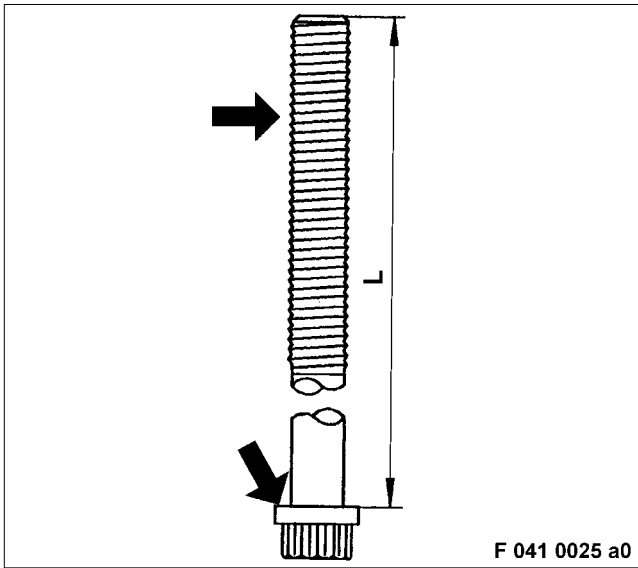

Measure shaft length (L) of double-hex screws with depth gauge.

For max. permissible shaft length – see C 041.05.01.

Coat threads and bolt head seating surfaces (arrows) with engine oil.

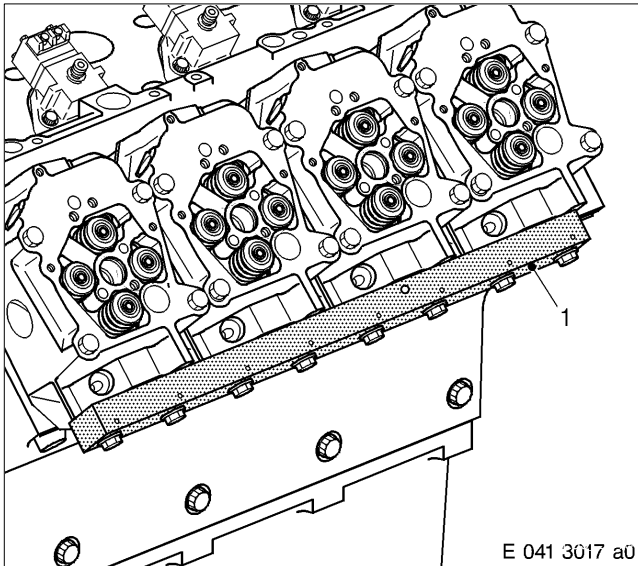

Fit double hex screws but do not tighten.

Mount alignment tool (1) on the outlet channels of the cylinder heads and tighten.

Note: Carefully align the cylinder heads; otherwise this could result in warping and cracks in the exhaust and constant-pressure manifold.

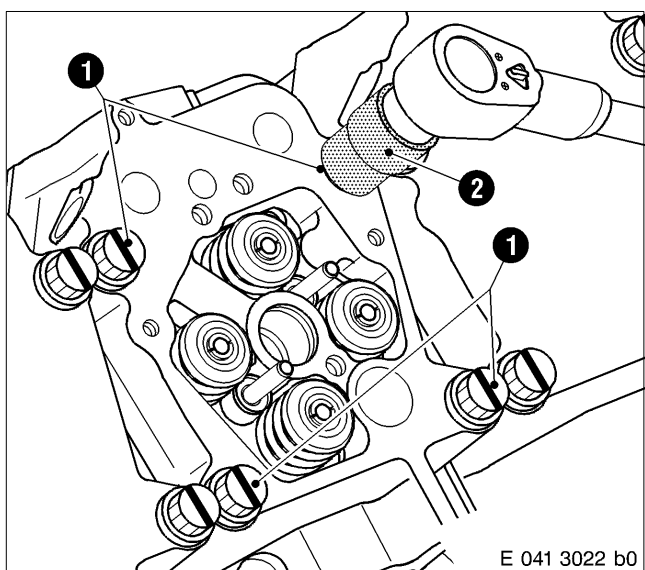

Note: To ensure that the cylinder head remains in correct position, all prescribed tightening torque stages and tightening sequence in accordance with cylinder head tightening diagram, see C 041.05.01, must be observed.

Tighten double-hex screws (1) for cylinder head with socket (2) in stages to specified pretightening torque in prescribed sequence in accordance with cylinder head tightening diagram.

Mark screw heads.

Tighten double-hex screws in specified sequence to angle of rotation in accordance with tightening specifications.

If the tightening torque or angle of rotation is exceeded for a cylinder head screw, remove all cylinder head screws, check shaft (replace cylinder head screw if necessary) and retighten to tightening specification.

Note: Cylinder head screws are not retightened!

C 041.05.12 After-Installation Operations

A distinction must be made as to whether:

- 1 ————— The engine is to be completely disassembled
- 2 ————— The engine is to be removed but not disassembled
- 3 ————— The engine is to remain installed

1	2	3	Operations	See
x	—	—	Perform operations as per Assembly Plan	B 005
x	—	—	Install engine	B 007
—	x	x	Install pushrods	C 054.05
—	x	x	Install rocker arm assembly	C 055.05
—	x	x	Adjust valve clearance	C 055.05.11
—	x	x	Connect leak-off fuel lines	C 086.05
—	x	x	Install H.P. fuel line	C 073.05
—	x	x	Install cylinder head cover	C 055.10
—	x	x	Install crankcase breather	C 018.10
—	x	x	Install exhaust manifold	C 142.05
—	x	x	Install turbocharger	C 101.01
—	x	x	Install charge air manifold	C 124.05
—	x	x	Install air pipework before exhaust turbocharger	—
—	x	x	Install guide tube and oil dipstick	C 182.10
—	x	x	Install filling pipe for engine oil	C 182.10
—	—	x	Fill engine coolant system	Operating Instructions
—	—	x	Release engine start	Operating Instructions



Contents

C 050	Valve Gear
C 051.05	Camshaft
C 051.05.01	General view
C 051.05.02	Special tool
C 051.05.04	Before-removal operations
C 051.05.05	Removal
C 051.05.08	Inspection and repair
C 051.05.11	Installation
C 051.05.12	After-installation operations
C 054.05	Valve roller tappets, pushrods
C 054.05.01	General view
C 054.05.02	Special tool
C 054.05.04	Before-removal operations
C 054.05.05	Removal
C 054.05.08	Inspection and repair
C 054.05.11	Installation
C 054.05.12	After-installation operations
C 055.05	Valve drive
C 055.05.01	General view
C 055.05.02	Special tool
C 055.05.04	Before-removal operations
C 055.05.05	Removal
C 055.05.06	Disassembly
C 055.05.08	Inspection and repair
C 055.05.10	Assembly
C 055.05.11	Installation
C 055.05.12	After-installation operations
C 055.10	Cylinder head cover
C 055.10.01	General view
C 055.10.04	Before-removal operations
C 055.10.05	Removal
C 055.10.08	Inspection and repair
C 055.10.11	Installation
C 055.10.12	After-installation operations

C 050 Valve Gear

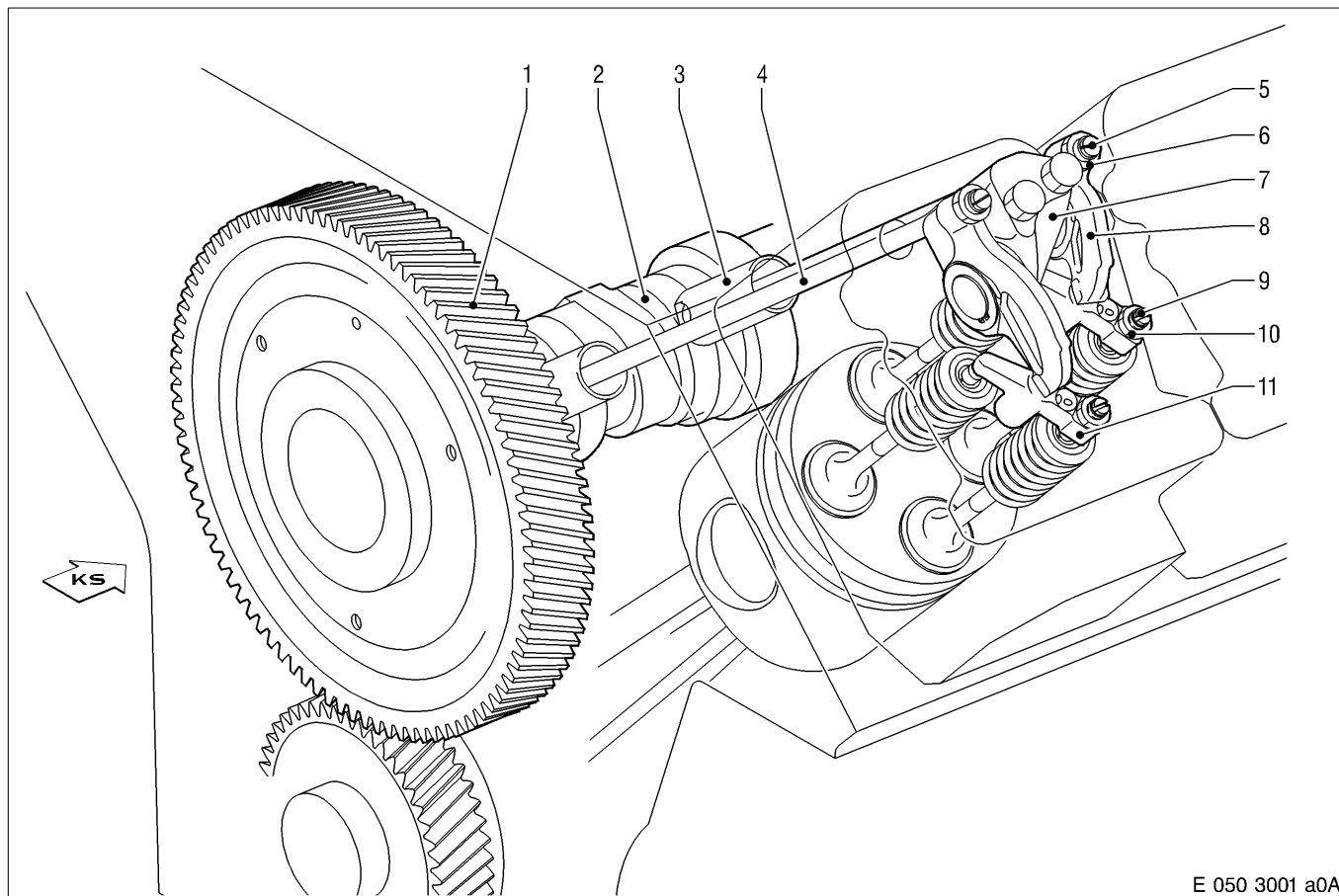

E 050 3001 a0A

- | | |
|-------------------|------------------------|
| 1 Camshaft gear | 7 Rocker shaft support |
| 2 Camshaft | 8 Rocker arm, inlet |
| 3 Roller tappet | 9 Adjusting screw |
| 4 Push rod | 10 Nut |
| 5 Adjusting screw | 11 Valve bridge |
| 6 Nut | |

The following is a list of auxiliary equipment and materials needed for the assembly operations:

	CAUTION
<p>When using these miscellaneous materials, it is essential to observe the Manufacturer's Instructions for use, safety instructions and waste disposal specifications.</p>	

Materials and consumables	Designation	Order No.		Remarks
		MTU	DDC	
Emery cloth				
Magnifying glass				
Spray gun				
Inspection lamp				
Vaseline	Petroleum jelly, white	40317		
Engine oil				
Kerosene or diesel fuel				
Cleaning agent	Solvclean KW	40022		
Corrosion preventive	Caramba Express	40008		
Denaturated ethanol		40250		
Engineer's blue	Blue	40641		
Multipurpose grease	Shell Retinax A	40333		
Dry compressed air				
Magnetic crack-testing equipment with fluorescent magnetic powder				
Surface crack-testing equipment with red penetrant dye				



C 051.05 Camshaft

C 051.05.01 General View

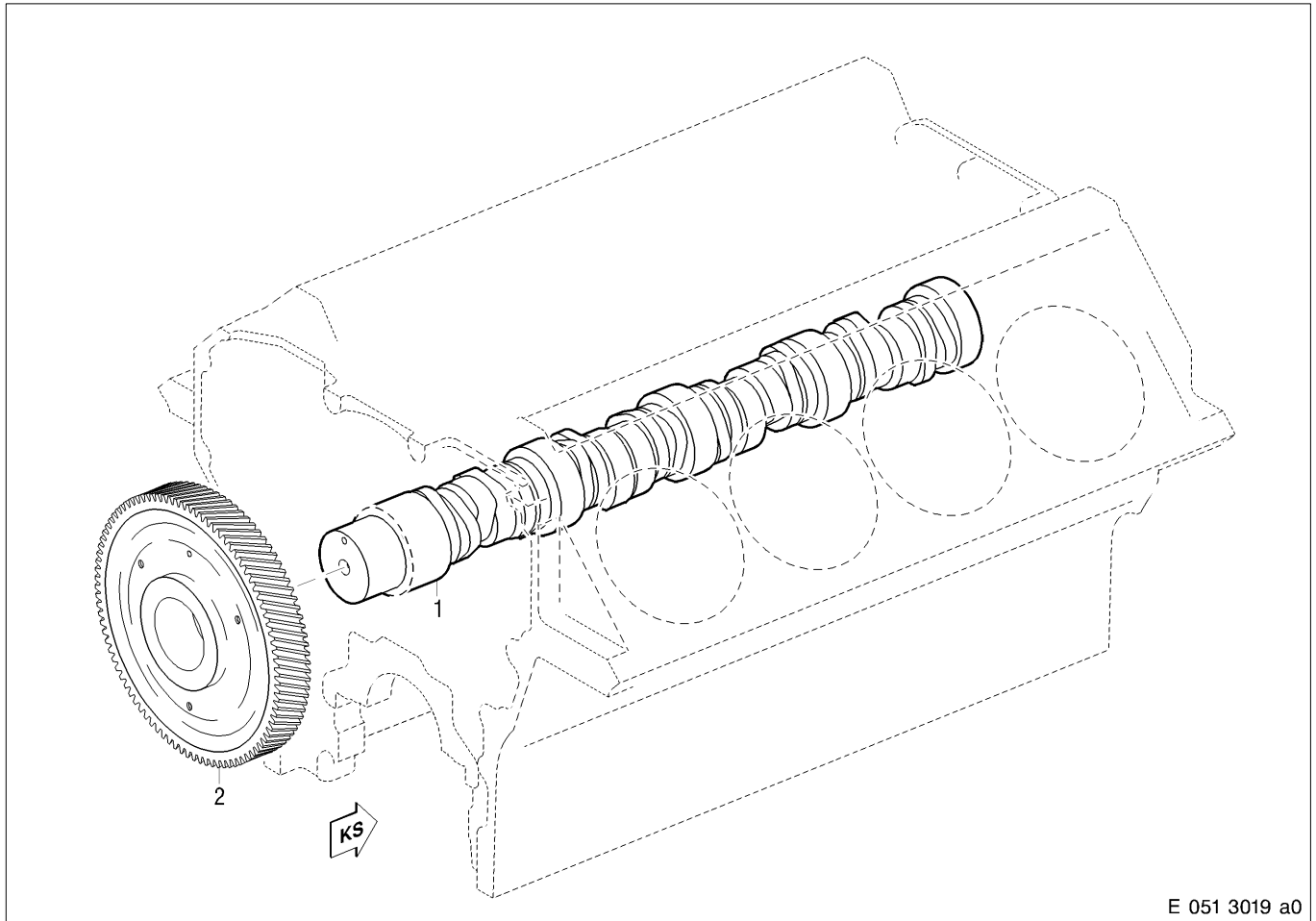

- 1 Camshaft
- 2 Camshaft gear

C 051.05.02 Special Tool

Designation – Application	Number
Insertion sleeve for camshaft	1
Measuring unit (TDC position)	1
Barring tool	1

C 051.05.04 Before-Removal Operations

A distinction must be made as to whether:

- 1 ————— The engine is to be completely disassembled
- 2 ————— The engine is to be removed but not disassembled
- 3 ————— The engine is to remain installed

1	2	3	Operations	See
x	-	-	Remove engine	B 003
x	-	-	Perform operations as per Disassembly Plan	B 004
-	x	x	Removal not scheduled	-

C 051.05.05 Removal

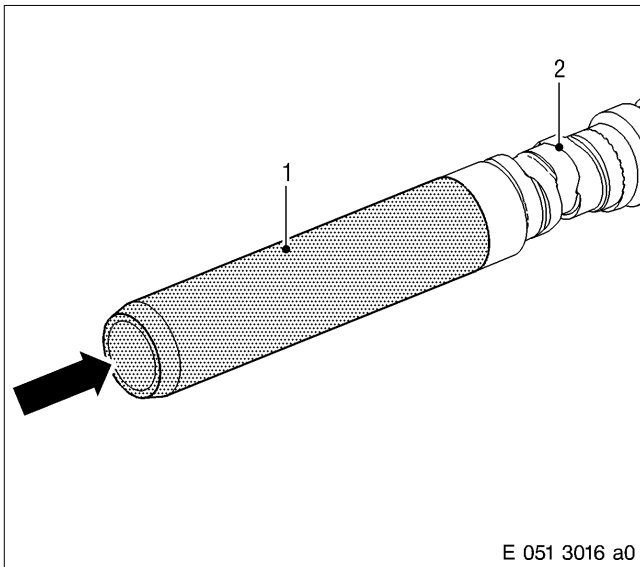

Removing camshaft

Attach (arrow) insertion sleeve (1) to front of the camshaft (2) fitted in the crankcase.

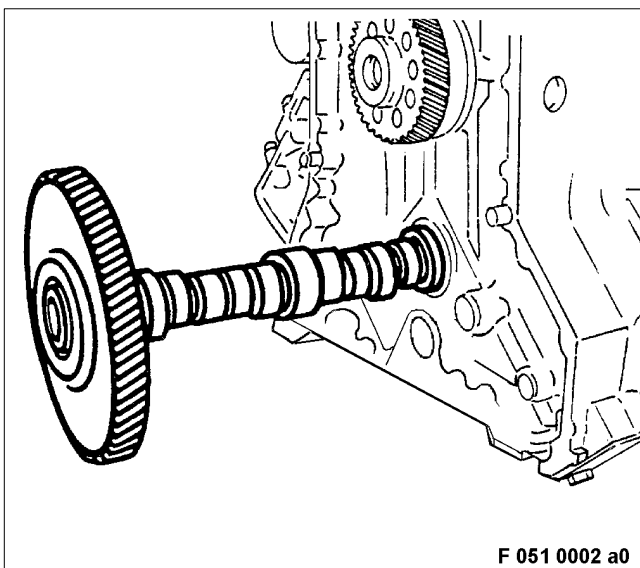

! WARNING

**Heavy object.
 Risk of injury!
 Use suitable tools and lifting equipment.**

Carefully pull camshaft out of crankcase taking care not to damage bearing.
 Remove insertion sleeve.

C 051.05.08 Inspection and Repair

Clean camshaft.

Pre-polish bearing journals and cams with emery cloth.

Using the magnetic crack-testing method with fluorescent magnetic powder, check camshaft for cracks; replace camshaft if necessary.

Check camshaft gear tooth flanks, axial sliding surface, bearing running surfaces and roller running track for scoring, wear and indentations.

Remove minor scoring, wear and indentations by polishing with emery cloth or oilstone; if necessary, machine to MTU and or DDC specifications or replace camshaft.

For limit values, see Tolerances and Wear Limits List.

Check condition of dowel pins for speed transmitter in camshaft gear, replace if necessary.

Measure projection of dowel pins. Specified projection = from 8.6 mm to 8.8 mm.

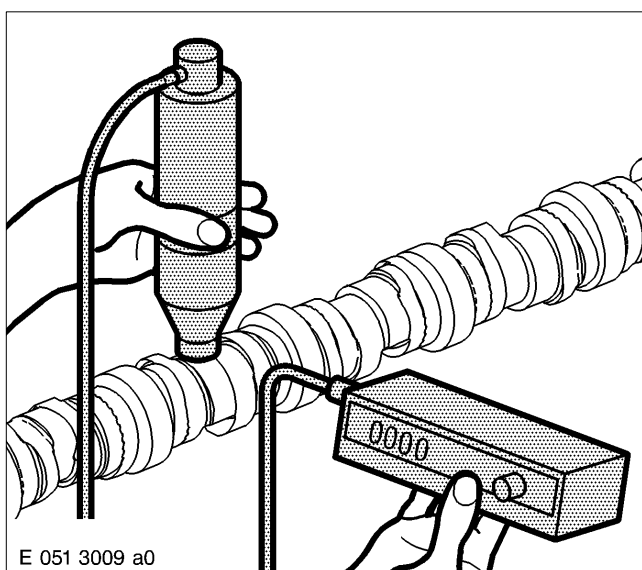

Checking hardness of cam and journal

Check hardness of cam (inlet and exhaust valves, plug-in pump) and journal on camshaft using Microdur testing unit or another suitable hardness testing unit.

Test hardness of each journal at four points at 90° intervals around circumference.

For limit values, see Tolerances and Wear Limits List.

If limit values are not achieved, machine camshaft to MTU or DDC specifications or replace as necessary.

Required hardness = 60 HRC \pm 2 HRC

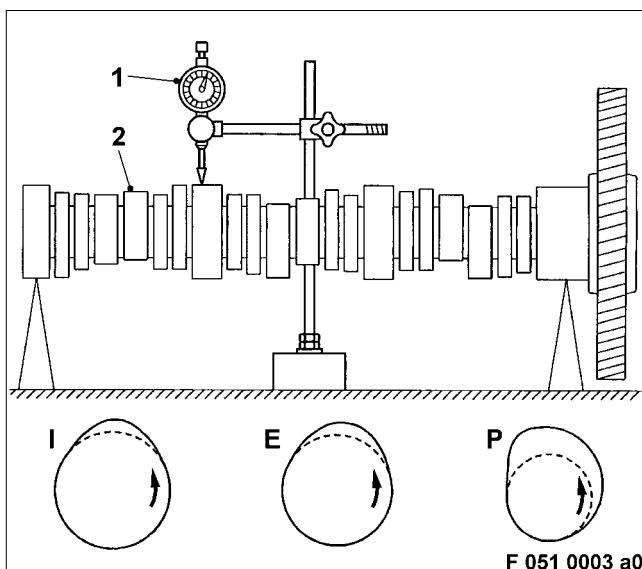

Checking concentricity and cam lift

Set camshaft (2) at outer journals on V-blocks or roller stands.

Measure radial runouts of all cam base circles and bearings with dial gauge (1).

Using a dial gauge, measure cam lift of all valve cams of inlet valves (I) and exhaust valves (E) including plug-in pump (P) cams.

For limit values, see Tolerances and Wear Limits List.

If limit values are not achieved, machine camshaft to MTU or DDC specifications or replace as necessary.

C 051.05.11 Installation

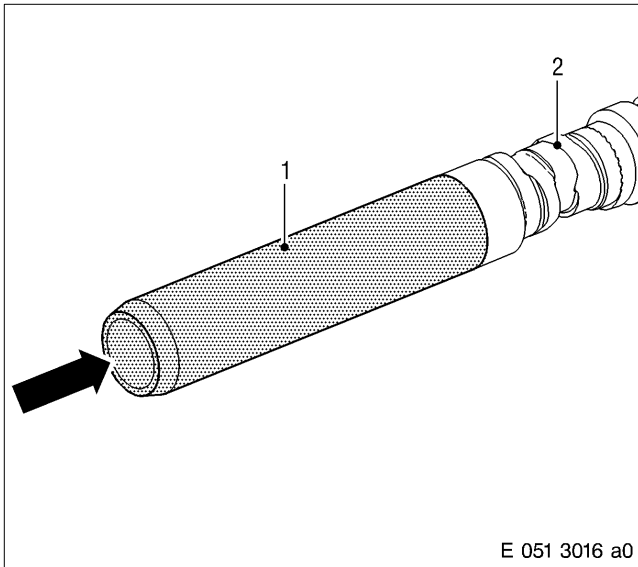

Installing camshaft

Note: Make sure all components are perfectly clean.

Attach (arrow) insertion sleeve (1) to front of the camshaft (2).

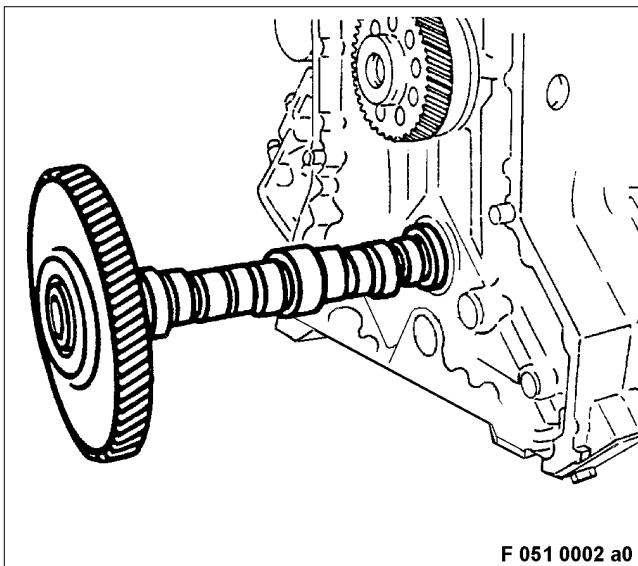

! WARNING

**Heavy object.
Risk of injury!
Use suitable tools and lifting equipment.**

Wipe down camshaft with chamois leather

Spray camshaft, camshaft bearing and insertion sleeve with engine oil.

Taking care not to damage bearings, slowly introduce camshaft into crankcase up to last bearing.

Remove insertion sleeve.

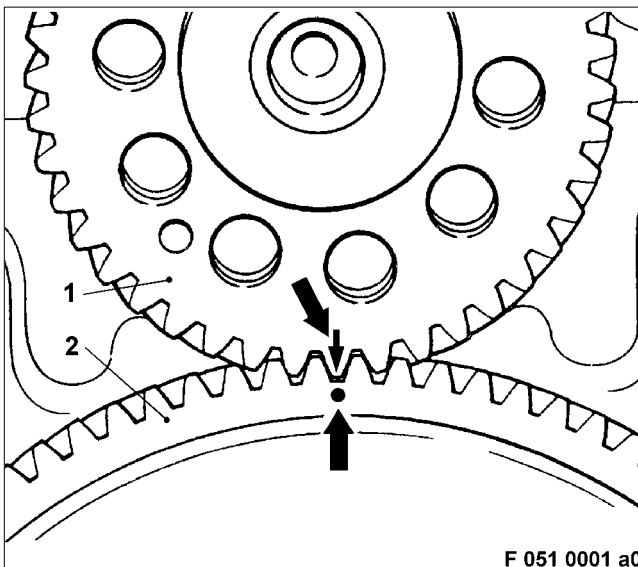

When installing the camshaft with the crankshaft already in position, ensure that the markings (arrows) in crankshaft gear (1) and camshaft gear (2) are aligned.

Note: Axially secure camshaft to ensure that it cannot fall out until flywheel housing is installed.

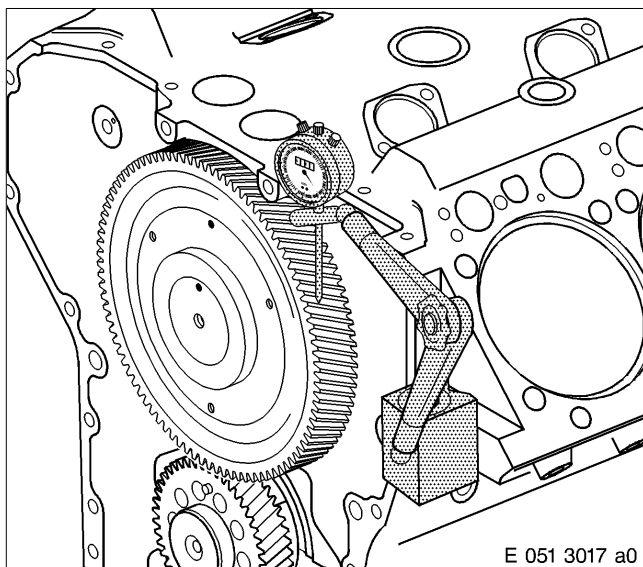

Measuring backlash

Measure backlash of camshaft after crankshaft has been installed, see C 031.05.

Mount magnetic dial gauge holder with dial gauge on crankcase.

Position dial gauge stylus with low preload on one tooth flank of camshaft gear.

Set dial gauge to zero.

Check backlash by moving camshaft gear back and forth.

For backlash, see C 020.

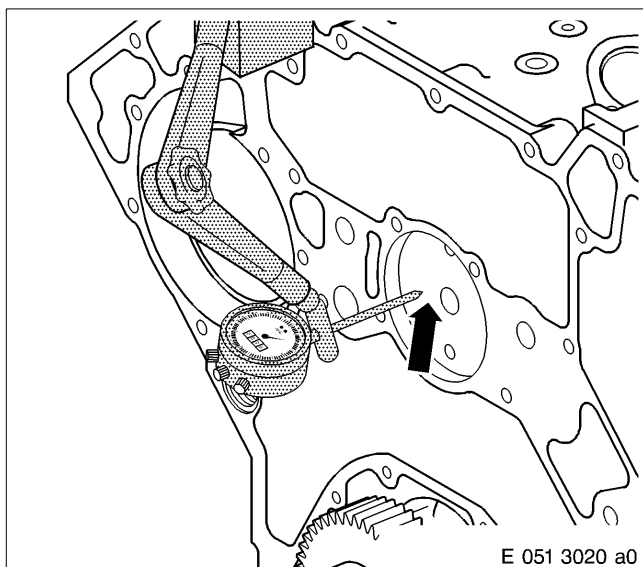

Measuring camshaft axial play

Measure camshaft axial play after flywheel housing has been installed – see C 021.05.

Mount magnetic dial gauge holder with dial gauge on crankcase, free end.

Position dial gauge stylus against front end of camshaft (arrow).

Press camshaft on camshaft gear axially as far as it will go.

Set dial gauge with preload to zero.

Move camshaft from stop to stop and record measured value (axial clearance).

For axial clearance – see C 020.

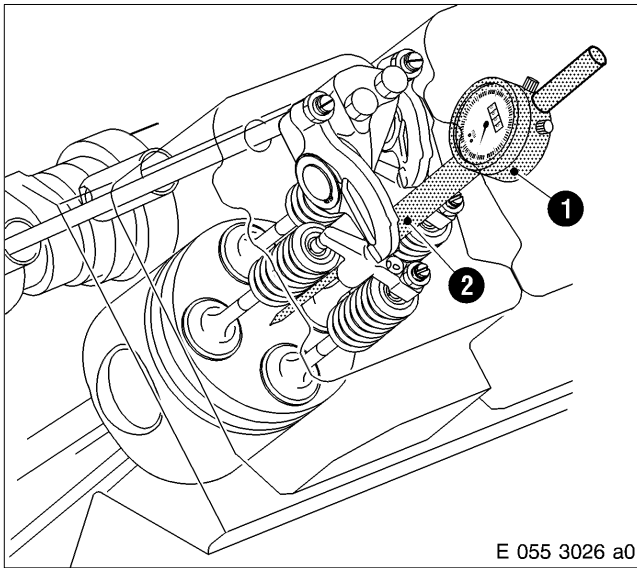

Checking camshaft timing

Note: Check injection timing with cylinder head and valve drive in position.

Fix TDC position of piston in the following way:

Install measuring unit (2) with dial gauge (1) into cylinder head A1.

Mount a suitable TDC indicator to the flywheel housing or on the crankcase (free end) in order to stamp the TDC mark on flywheel or vibration damper.

Using the barring tool, bar the engine until the piston of cylinder A1 is in the firing TDC.

Note: If both rocker arms are relieved, i.e. have clearance, the piston is firing TDC.

Move piston several times up and down through TDC until needle of dial gauge registers its highest reading.

Set dial gauge to zero.

Back off crankshaft approx. 20° against direction of rotation.

Move the crankshaft in direction of rotation to 0.3 mm (dial gauge reading) before TDC and place a precise marking (e.g. with scriber) on flywheel or vibration damper opposite the tip of the TDC indicator.

Bar crankshaft in direction of rotation past TDC to approx. 20° (to take up bearing play).

Bar crankshaft in direction opposite to normal direction of rotation to 0.3 after TDC and make a second mark.

Note: To eliminate bearing clearance, the piston must always move in direction of TDC.

Make the third alignment mark exactly in the middle of the other two marks. This is the TDC position of the piston.

Remove measuring device with dial gauge.

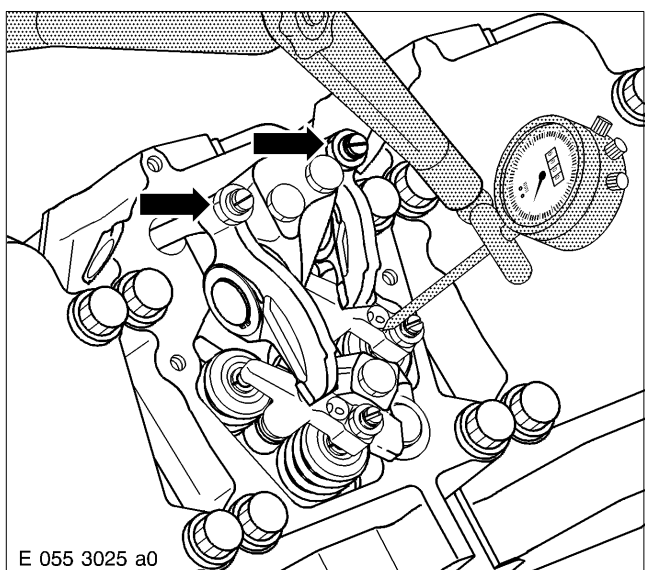

Measure valve stroke as follows:

Release locknuts (arrows) and insert adjusting screws until there is no more play and then slightly tighten locknuts.

Note: Ensure there is no valve play in order to obtain valid measurements!

Mount magnetic-base indicator holder with dial gauge on cylinder A1.

Position dial gauge stylus with low preload on valve bridge of inlet valve and set scale to zero.

Turn the crankshaft slowly in engine direction of rotation 360° and align exactly with the overlap TDC in accordance with existing alignment marks.

Read valve stroke from dial gauge and record readings in Data Sheet.

Position dial gauge stylus on valve bridge of exhaust valve and set scale to zero.

Further rotate crankshaft slowly in engine direction of rotation until pointer of dial gauge no longer moves.

Read valve stroke from dial gauge and record readings in Data Sheet.

For specified values, see A 004.

Check camshaft if tolerance deviation is above permitted level.

Remove magnetic-base indicator holder with dial gauge and TDC indicator.

Set valve clearance on cylinder A1 – see C 055.05.11.

C 051.05.12 After-Installation Operations

A distinction must be made as to whether:

- 1 ————— The engine is to be completely disassembled
- 2 ————— The engine is to be removed but not disassembled
- 3 ————— The engine is to remain installed

1	2	3	Operations	See
x	—	—	Perform operations as per Assembly Plan	B 005
x	—	—	Install engine	B 007



C 054.05 Valve Roller Tappets, Pushrods

C 054.05.01 General View

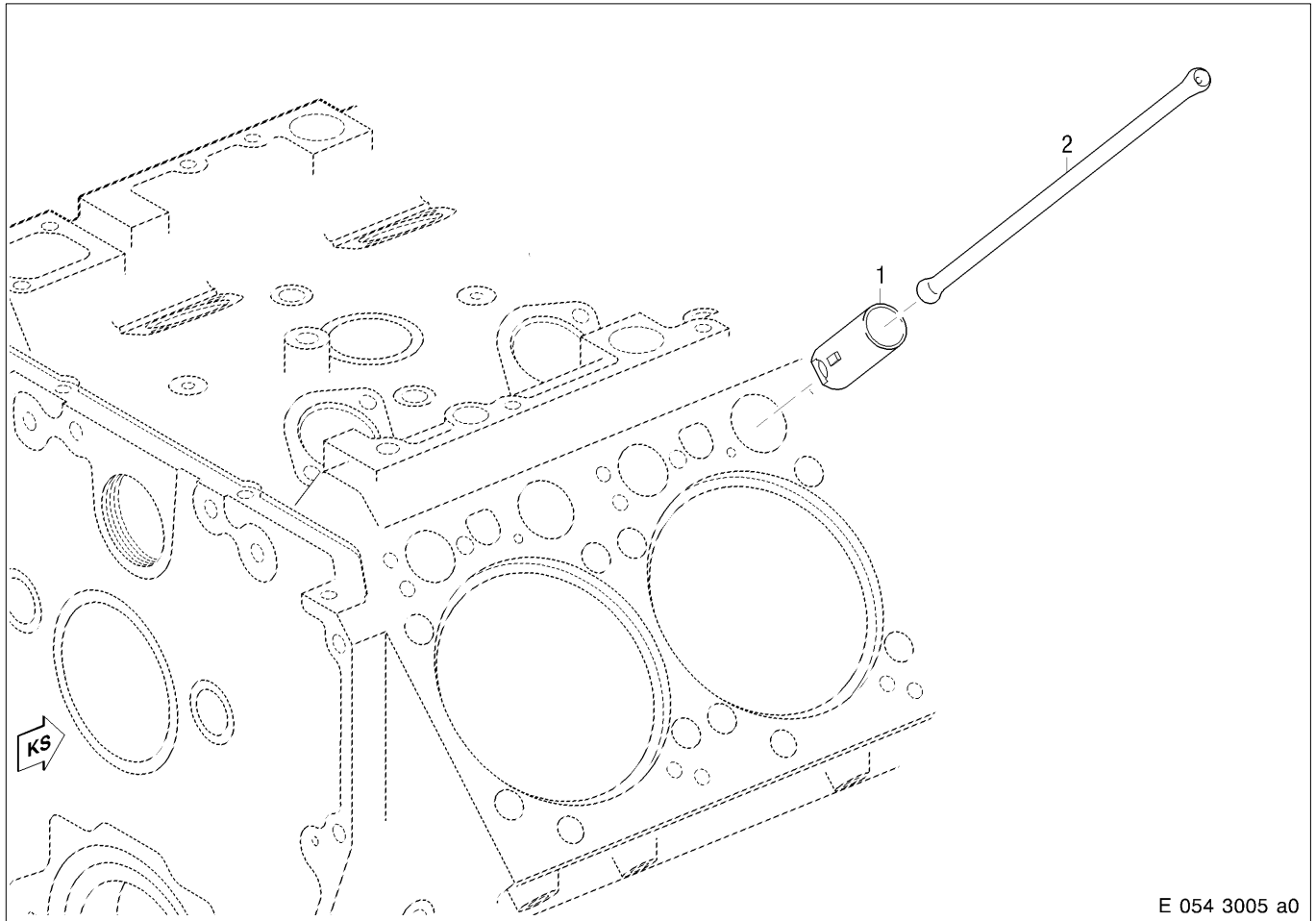

E 054 3005 a0

- 1 Roller tappet
- 2 Push rod

C 054.05.02 Special Tool

Designation – Application	Number
Gripper pliers for roller tappet	1

C 054.05.04 Before-Removal Operations

A distinction must be made as to whether:

- 1 ————— The engine is to be completely disassembled
- 2 ————— The engine is to be removed but not disassembled
- 3 ————— The engine is to remain installed

1	2	3	Operations	See
x	-	-	Remove engine	B 003
x	-	-	Perform operations as per Disassembly Plan	B 004
-	-	x	Disable engine start	Operating Instructions
-	-	x	Drain engine coolant*	Operating Instructions
-	x	x	Remove air supply system before turbocharger (if necessary)	-
-	x	x	Remove crankcase ventilation (if necessary)	C 018.10
-	x	x	Release or remove charge air manifold*	C 124.05
-	x	x	Remove exhaust manifold*	C 142.05
-	x	x	Remove cylinder head cover	C 055.10
-	x	x	Remove H.P. fuel line*	C 073.05
-	x	x	Disconnect leak-off fuel lines*	C 086.05
-	x	x	Remove rocker arm assembly	C 055.05
-	x	x	Remove cylinder head *	C 041.05

* - only when removing valve roller tappets

C 054.05.05 Removal

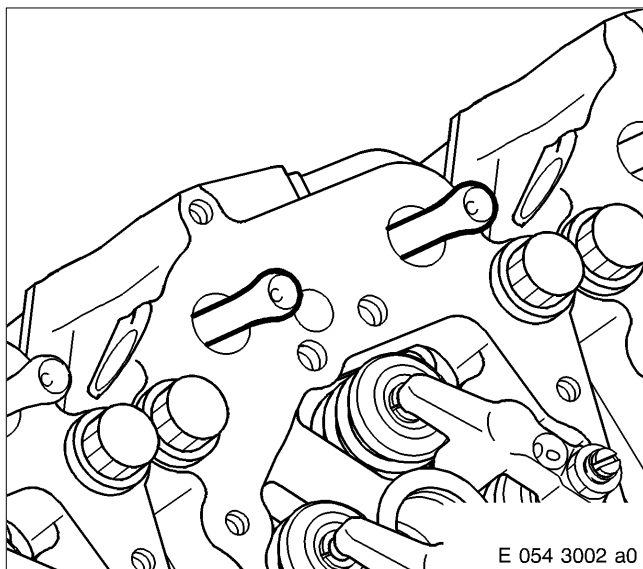

Removing pushrods

Remove push rods from roller tappet.

When withdrawing the push rods, rotate them so that they are released from the roller tappet and the roller tappet is not pulled out of the crankcase.

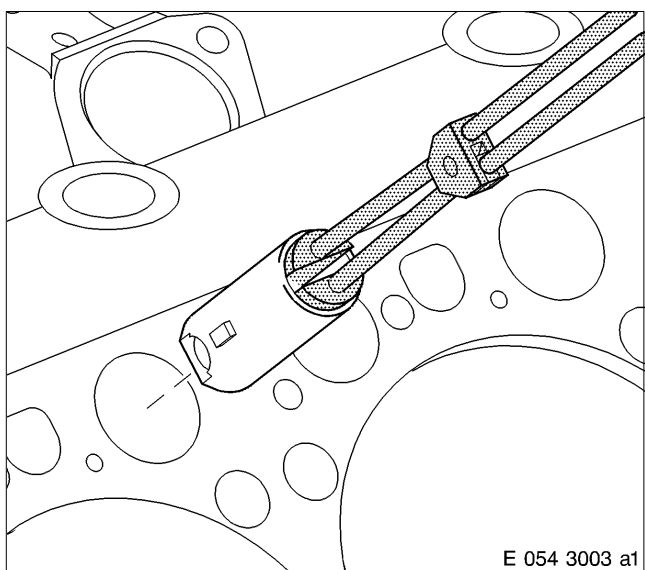

Removing roller tappets

For instructions on removing cylinder head – see C 041.05.

Using gripping pliers, remove roller tappet from crankcase.

Mark roller tappet in relation to crankcase.

C 054.05.08 Inspection and Repair

Clean all components.

Using the magnetic crack-testing method with fluorescent powder, check roller tappet and pushrod for cracks; replace components if cracks are detected.

Check roller tappet for damage and wear.

If there is excess wear or damage, replace roller tappet.

Check tappet roller for ease-of-movement and excessive play.

Replace roller tappet if play is too great or tappet is sluggish.

Measure outside diameter of roller tappet with micrometer.

For limit values – see Tolerances and Wear Limits List.

If measurements are below limit value, replace roller tappet.

Check pushrod seat and ball socket of push rod for wear; replace push rod if necessary.

Check concentricity of push rod; replace push rod if necessary.

C 054.05.11 Installation

Note: Make sure all components are perfectly clean.

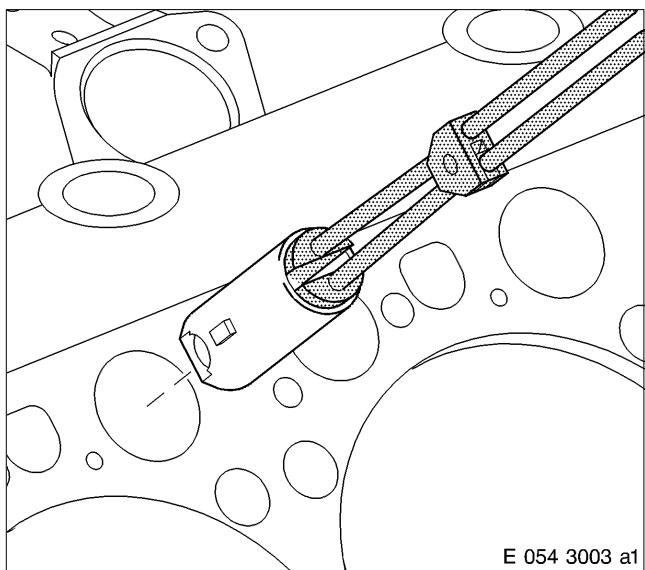

Installing roller tappets

Coat roller tappet and bore in crankcase with engine oil.

Observe the roller tappet marking (installation point).

Using pliers, insert tappet into guide bore in crankcase, making sure that slot is correctly positioned.

Note: Do not drop roller tappet onto camshaft.

Check that roller tappet moves freely in guide bore.

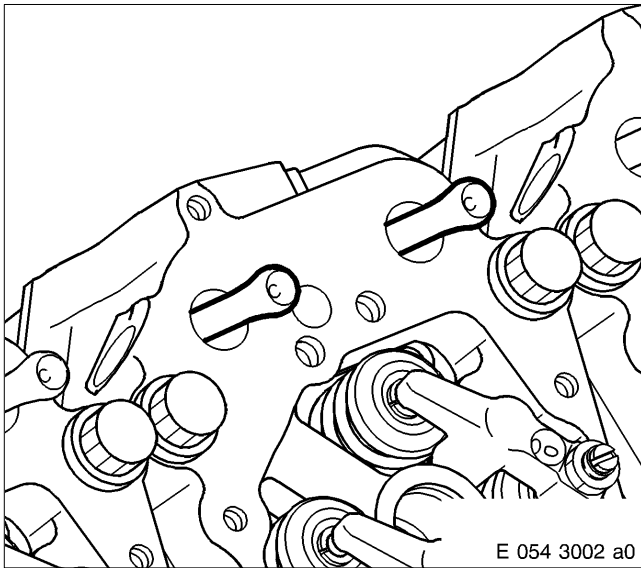

Installing pushrods

For instructions on installing cylinder head, see C 041.05.

Coat pushrod seats and ball sockets of push rods with engine oil.

Insert the push rod with the ball-head side through the cylinder head into the roller tappet making sure that it sits securely in the roller tappet.

C 054.05.12 After-Installation Operations

A distinction must be made as to whether:

- 1 ————— The engine is to be completely disassembled
- 2 ————— The engine is to be removed but not disassembled
- 3 ————— The engine is to remain installed

1	2	3	Operations	See
x	—	—	Perform operations as per Assembly Plan	B 005
x	—	—	Install engine	B 007
—	x	x	Install rocker arm assembly	C 055.05
—	x	x	Adjust valve clearance	C 055.05.11
—	x	x	Connect leak-off fuel lines	C 086.05
—	x	x	Install H.P. fuel line	C 073.05
—	x	x	Install cylinder head cover	C 055.10
—	x	x	Install exhaust manifold	C 142.05
—	x	x	Install charge air manifold	C 124.05
—	x	x	Install crankcase breather	C 018.10
—	x	x	Install air pipework before exhaust turbocharger	—
—	—	x	Fill engine coolant system	Operating Instructions
—	—	x	Release engine start	Operating Instructions

C 055.05 Valve Drive

C 055.05.01 General View

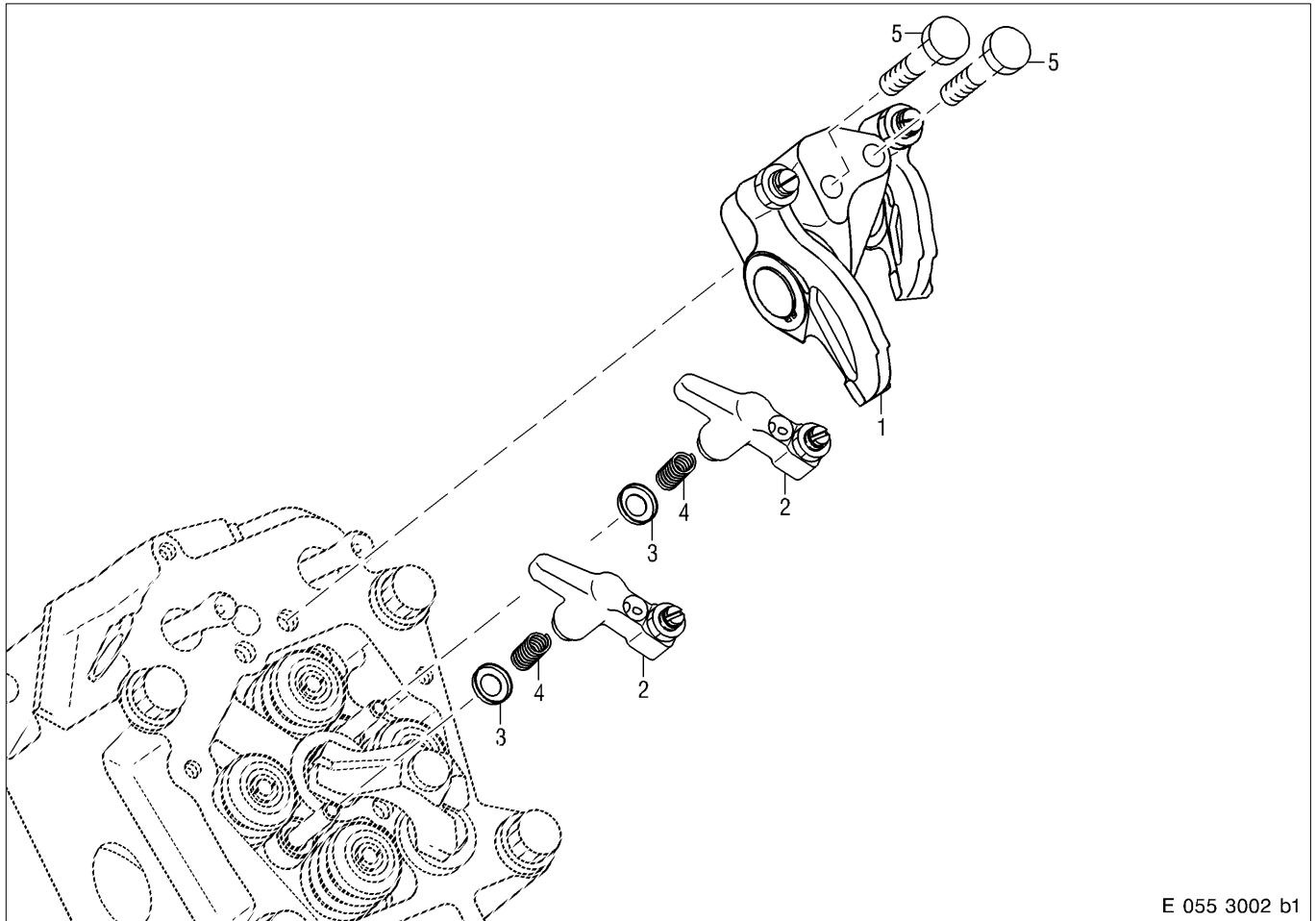

E 055 3002 b1

- 1 Rocker shaft support
 - 2 Valve bridge
 - 3 Spring guide
 - 4 Compression spring
 - 5 Hex screw
- | | |
|----------------------------|------------|
| Max. shaft length: | 91 mm |
| Pretightening torque: | 60 Nm |
| Angle of further rotation: | 90° |
| Lubricant: | Engine oil |

Rocker shaft support

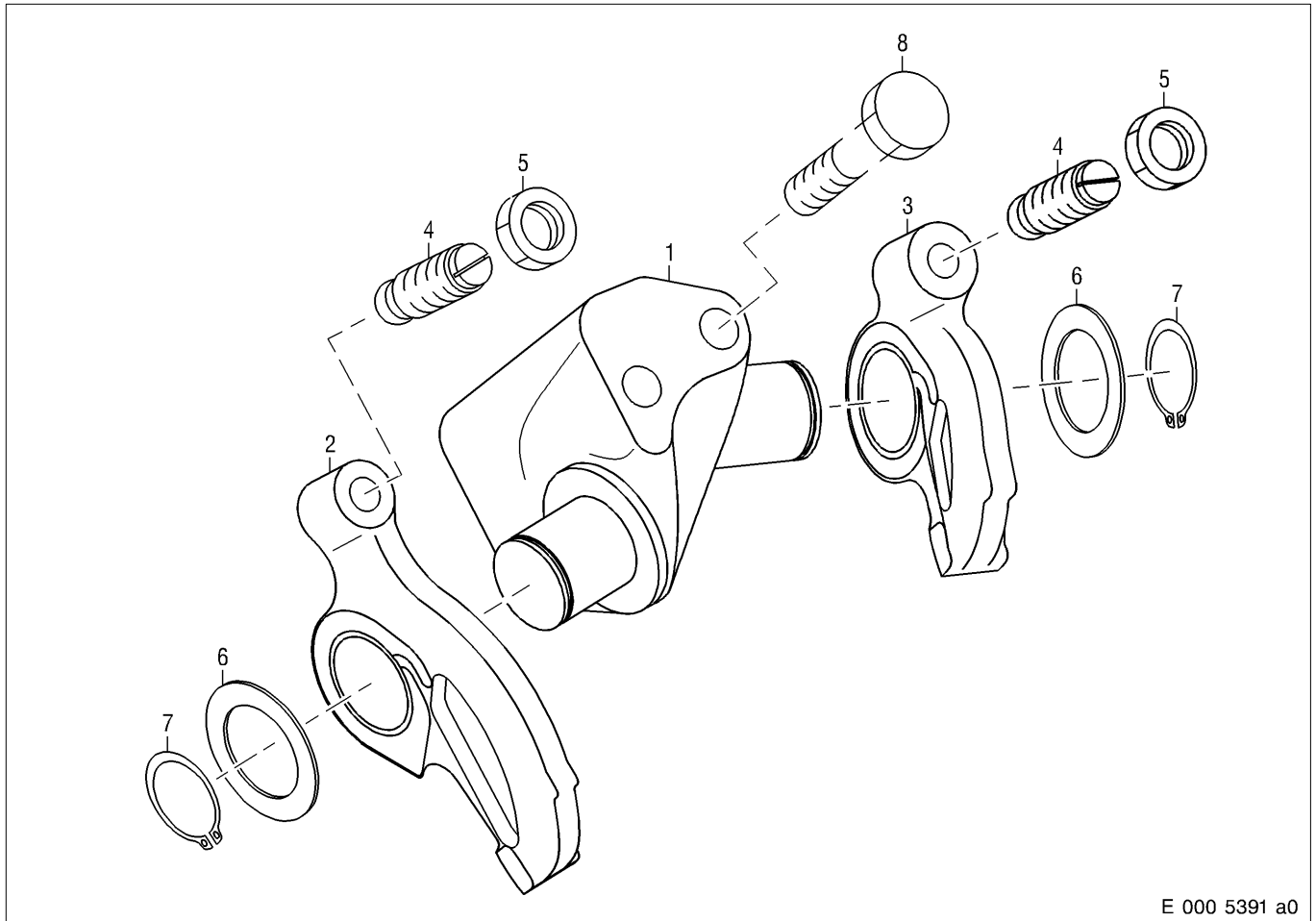

E 000 5391 a0

- 1 Rocker shaft support
- 2 Rocker arm, exhaust
- 3 Rocker arm, inlet
- 4 Adjusting screw
- 5 Nut
- Tightening torque: 50 Nm
- Lubricant: Engine oil

- 6 Washer
- 7 Snap ring
- 8 Hex screw
- Max. shaft length: 91mm
- Pretightening torque: 60 Nm
- Angle of further rotation: 90°
- Lubricant: Engine oil

Valve bridge

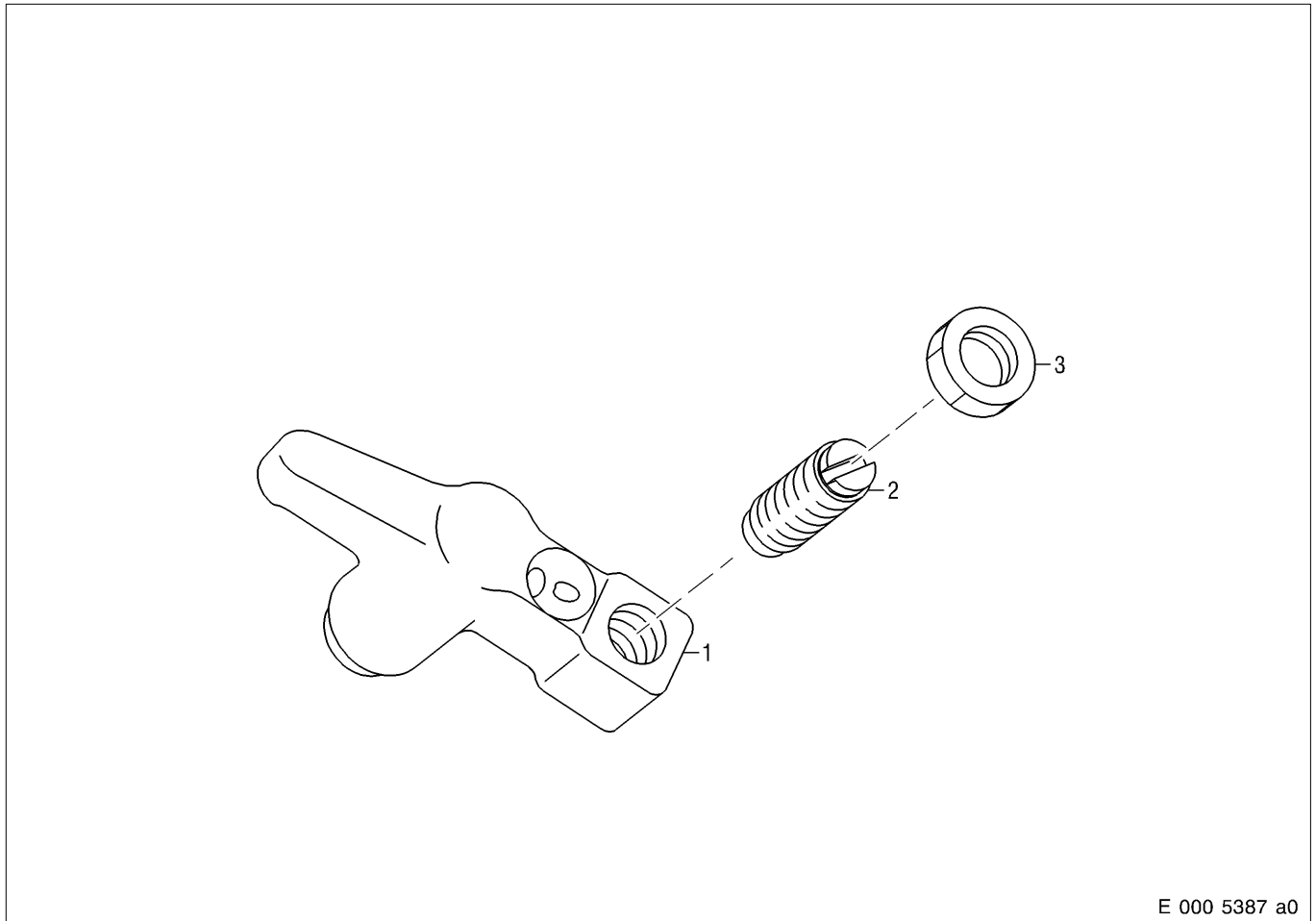

- 1 Valve bridge
 - 2 Adjusting screw
 - 3 Nut
- Tightening torque: 25 Nm + 5 Nm
Lubricant: Engine oil

C 055.05.02 Special Tool

Designation – Application	Number
Gauge 0.4 mm/0.6 mm, for setting valve clearance	1
Screwdriver, short, for setting valve clearance	1
Barring tool	1
Measuring unit (TDC position)	1

C 055.05.04 Before-Removal Operations

A distinction must be made as to whether:

- 1 — The engine is to be completely disassembled
- 2 — The engine is to be removed but not disassembled
- 3 — The engine is to remain installed

1	2	3	Operations	See
x	-	-	Remove engine	B 003
x	-	-	Perform operations as per Disassembly Plan	B 004
-	-	x	Disable engine start	Operating Instructions
-	x	x	Cylinder head cover removal	C 055.10

C 055.05.05 Removal

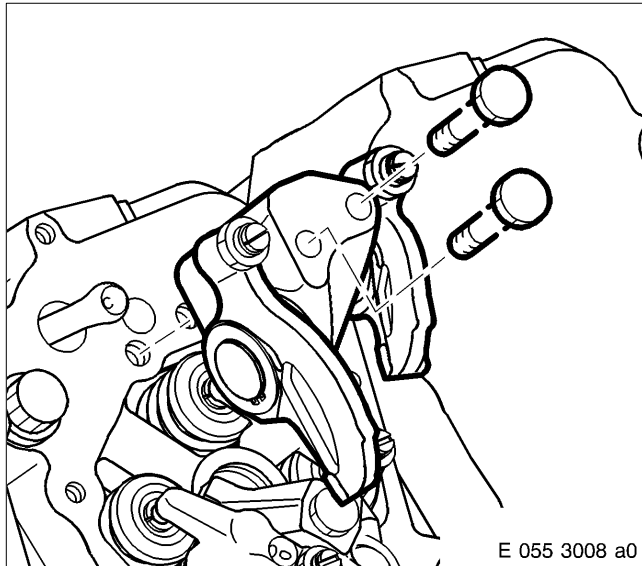

Removing rocker arm assembly

Remove hex bolts and remove rocker shaft support from cylinder head.

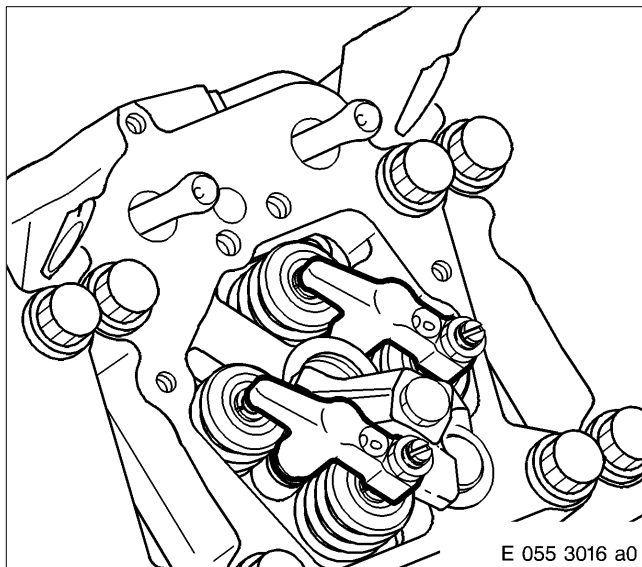

Mark valve bridges in relation to valves.
 Remove valve bridges, compression springs and spring guides from pins in cylinder head.

C 055.05.06 Disassembly

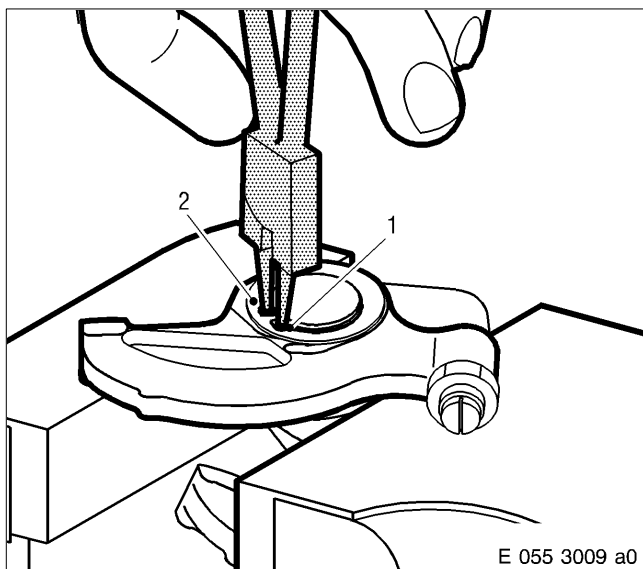

Disassembling rocker arm assembly

Clamp rocker shaft support in vice with aluminium jaws.

Release nuts of adjusting screws.

CAUTION

Snap ring pretension

Risk of injury.

Use suitable circlip pliers. Always wear protective goggles/safety mask.

Using snap ring pliers, remove snap ring (1) from shaft.

Remove washer (2).

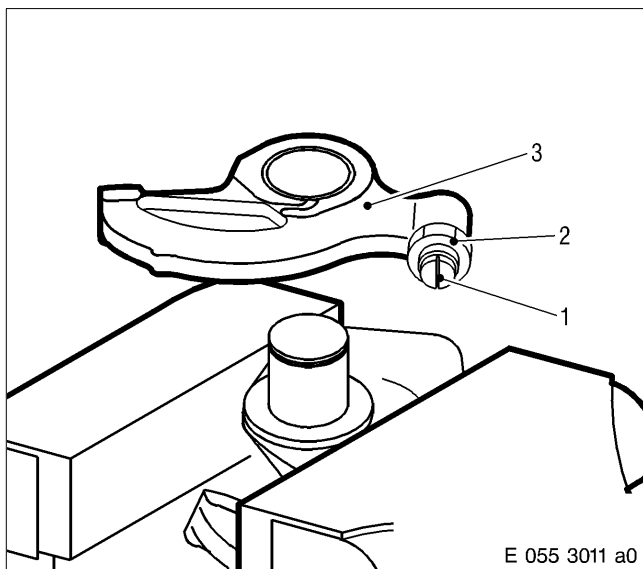

Remove rocker arm (3) from axle.

Remove nut (2) and adjusting screw (1).

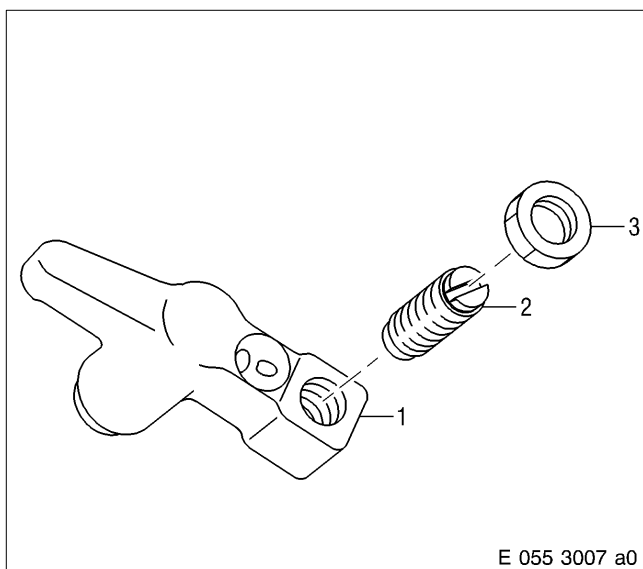

Clamp valve bridge (1) in vice with aluminium jaws.

Release nut (3) and remove adjusting screw (2).

C 055.05.08 Inspection and Repair

Clean all components.

Using the magnetic crack-testing method with fluorescent magnetic powder, check rocker shaft support and axles, rocker arms and valve bridges for cracks.

Replace cracked components.

Check running surfaces of axles, valve bridges and rocker arms for wear, indentations and scoring.

Remove scoring and indentations by polishing with emery cloth; replace components as necessary.

Check snap rings and washers for damage and wear; replace components as necessary.

Check condition of mating faces on rocker shaft support; burnish with oilstone if necessary.

Check condition of axle snap ring grooves; replace rocker shaft support as necessary.

Check tapers and slot of adjusting screws for wear and damage; replace component if necessary.

Check heads and seating faces of nuts for damage; replace adjusting screw as necessary.

Check threads of nuts and adjusting screws for ease of movement; replace component as necessary.

Check threaded bores in rocker arms and valve bridges for ease of movement; remachine if necessary.

Measure register bores in valve bridges with bore gauge.

For limit values – see Tolerances and Wear Limits List.

Check guide pins in cylinder head for wear and protrusion (A) – see C 041.05.08.

Replace snap rings during W6 overhaul.

Make sure that all components are perfectly clean and that flow through lube oil bores is unobstructed.

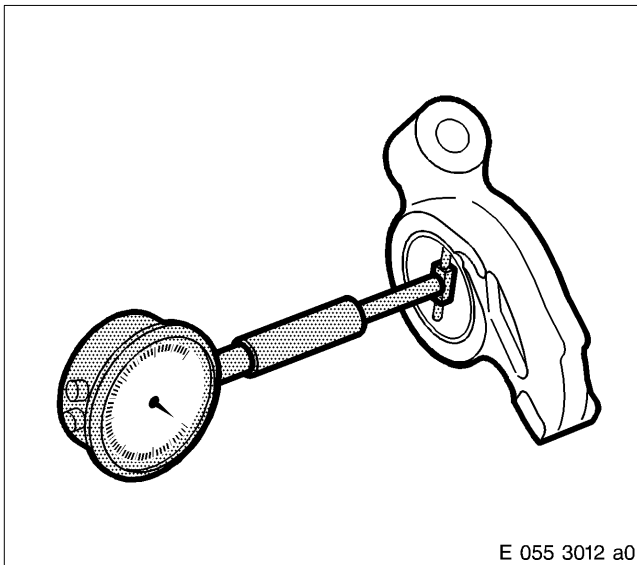

Measuring diameter of bush bore in rocker arm

Adjust bore gauge to basic size of bush bore and measure diameter of bore.

If limit values are exceeded, replace rocker arm.

For limit values, see Tolerances and Wear Limits List.

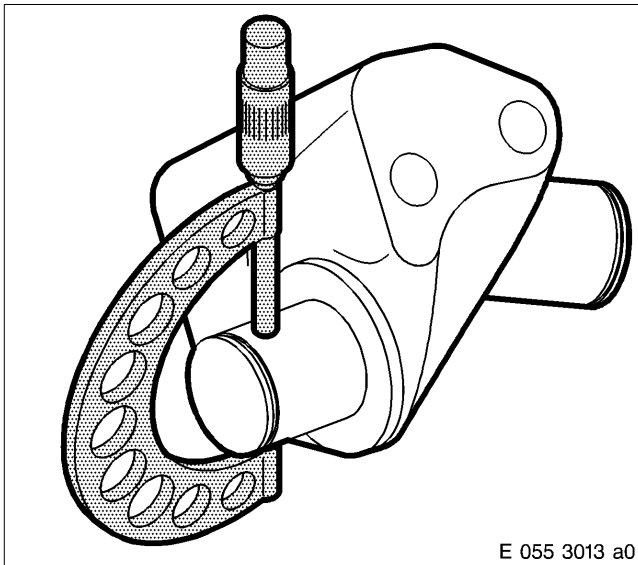

Measuring diameter of bearing pedestal axles

Using micrometer, measure outside diameters of bearings.

If measurements are below limit values, replace rocker shaft support.

For limit values, see Tolerances and Wear Limits List.

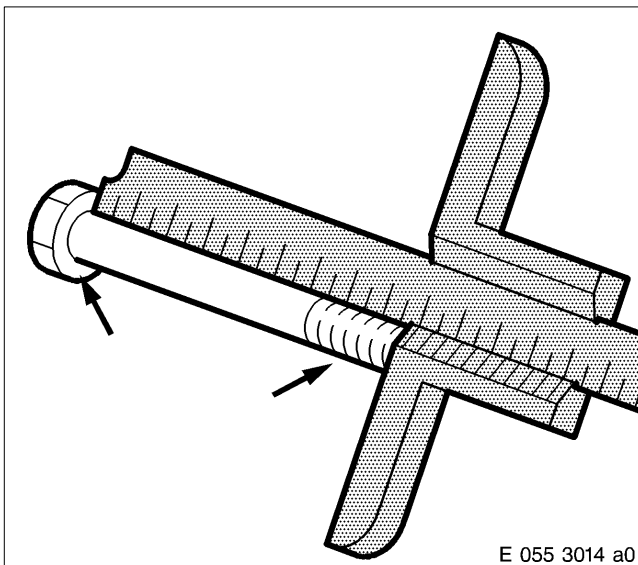

Checking hex bolts for rocker shaft support

Measure shaft length of hex bolt; for max. shaft length – see C 055.05.01.

Check that thread and screw head mating face (arrows) are in perfect condition; replace screw if necessary.

Check hexagon for damage; replace screw if necessary.

C 055.05.10 Assembly

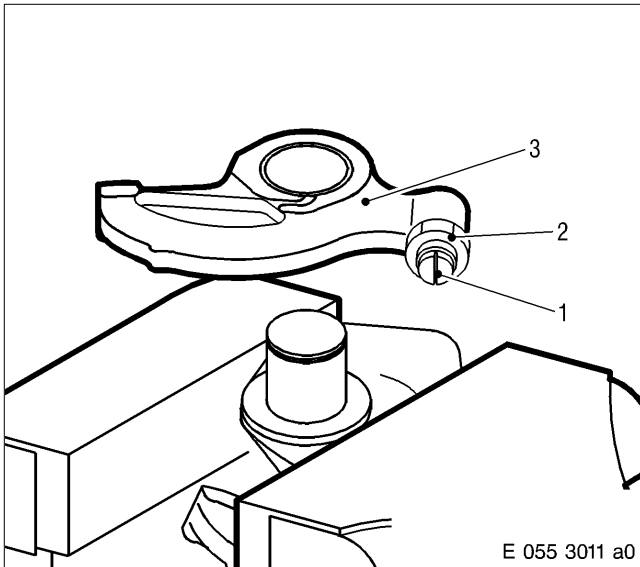

Assembling rocker arm assembly

Note: Make sure parts are perfectly clean.

Insert adjusting screw (1) into rocker arm (3).

Attach nut (2) to adjusting screw; do not tighten!

Coat axles on rocker shaft support and bushes of rocker arm with engine oil.

Clamp rocker shaft support in vice with aluminium jaws.

Fit rocker arm on axle.

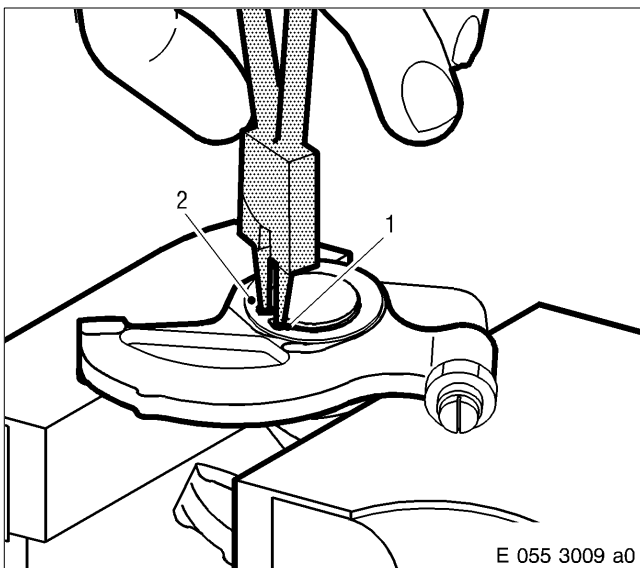

CAUTION

Snap ring pretension

Risk of injury.

Use suitable circlip pliers. Always wear protective goggles/safety mask.

Fit washer (2) and secure with snap ring (1).

Make sure that snap ring is correctly seated.

Check minimum axial clearance of rocker arm.

Install second rocker arm similarly.

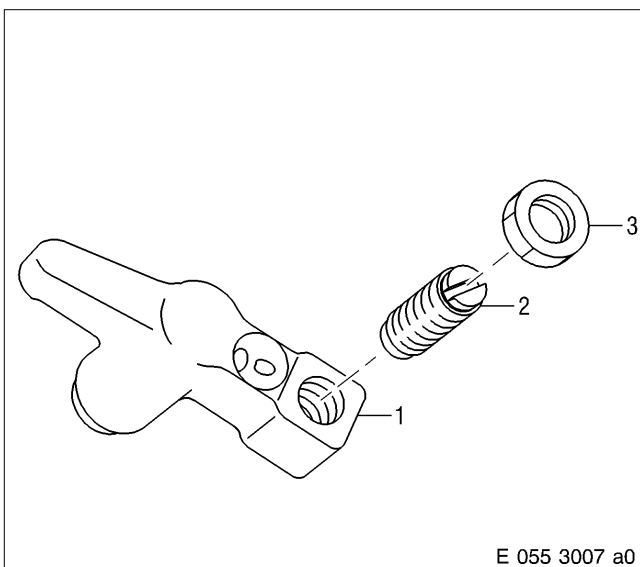

Insert adjusting screw (2) into valve bridge (1).

Attach nut (3) to adjusting screw; do not tighten!

C 055.05.11 Installation

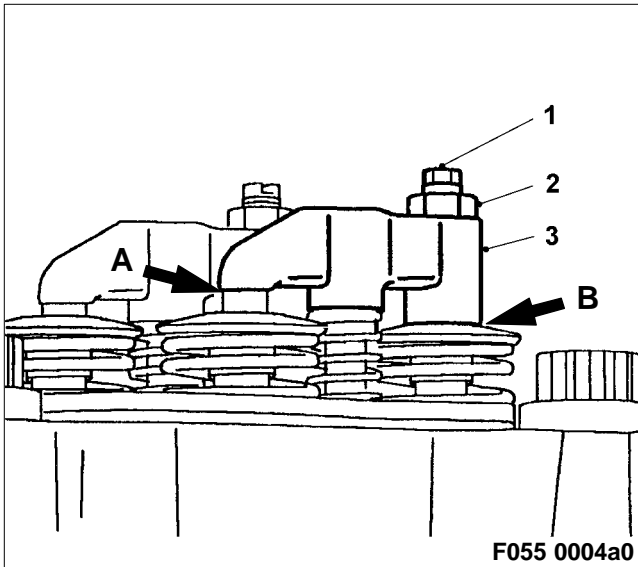

Adjusting and installing valve bridges

Note: Make sure parts are perfectly clean. Perform setting only with engine either cold or at operating temperature. Allow at least 30 minutes after engine shutdown before starting.

Measure protrusion of guide pins in cylinder head, see C 041.05.08.

Fit spring guides and compression springs on pins in cylinder head – see C 055.05.01.

Note: If the valve seat inserts in cylinder head or valves have been machined, the valve bridges must be adjusted.

Clamp the valve bridges (3) in the vice with aluminium jaws, release locknut (2) and back off adjusting screw (1) approx. 3 revolutions.

Fit valve bridge on pin in cylinder head in accordance with the markings (installation location).

Adjusting screws point to exhaust pipe.

Press and hold valve bridge down against the spring power. Valve bridge must make contact with valve stem (A), back off adjusting screw if necessary.

Manually insert adjusting screw with valve bridge pressed until adjusting screw just contacts valve stem (B); valve bridge must not move upwards.

Tighten locknut by hand.

Note: Valve bridges are set and must not be interchanged during installation!

Remove valve bridges from cylinder head.

Clamp valve bridges in the vice and tighten locknut to specified tightening torque – see C 055.05.01.

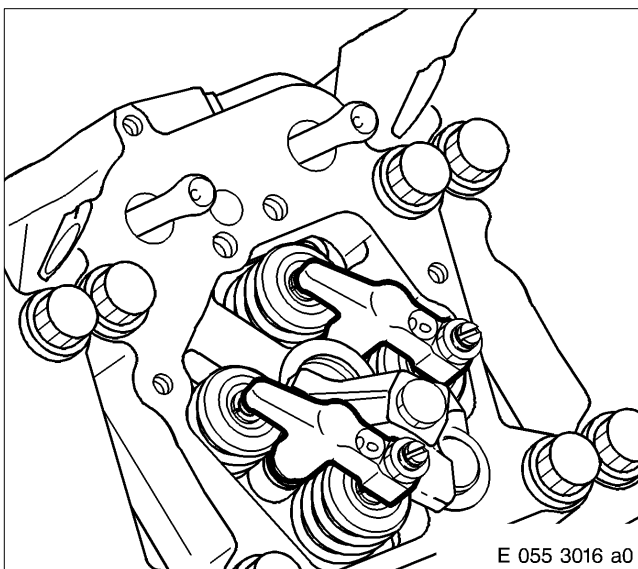

CAUTION

Compressed air is air which has been compressed under pressure. Risk of injury. If compressed air is used for blowing out or blow-drying components, always wear protective goggles or safety mask. Compressed air must not be directed at the body. Pressure must not exceed 3.0 bar (40 lb/in²).

Blow lube-oil bores of valve bridges clear with compressed air to check for obstructions.

Coat register bore of valve bridge with engine oil.

Fit valve bridges on pins in cylinder head in accordance with the markings (installation location).

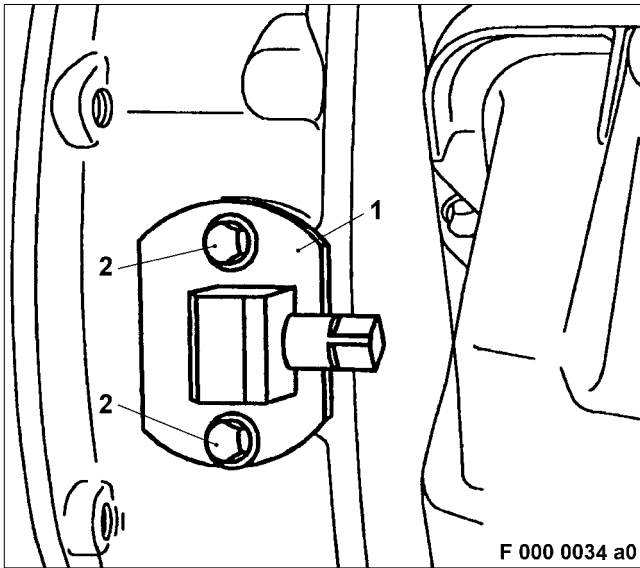

Installing rocker arm assembly

Remove end cover from flywheel housing.

Engage barring tool (1) with starter ring and mount on flywheel housing with screws (2).

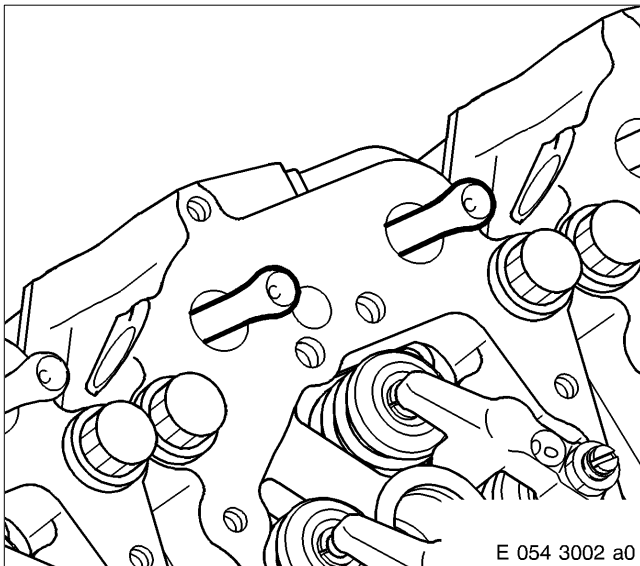

Using the barring tool, set piston of cylinder to be checked to firing TDC.

Note: In firing TDC, both roller tappets of the cylinder to be checked are in the camshaft basic circle.

Coat pushrod seats of push rods with engine oil.

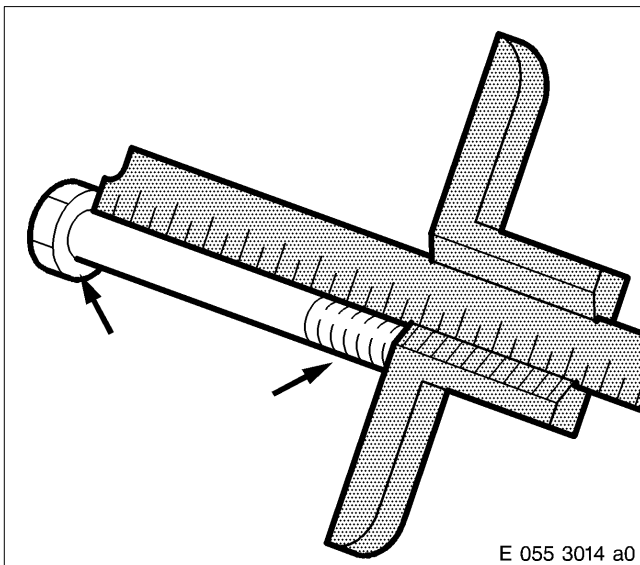

Measure shaft length of hex bolt; for max. shaft length – see C 055.05.01.

Coat thread and mating face (arrows) of hex screws with engine oil.

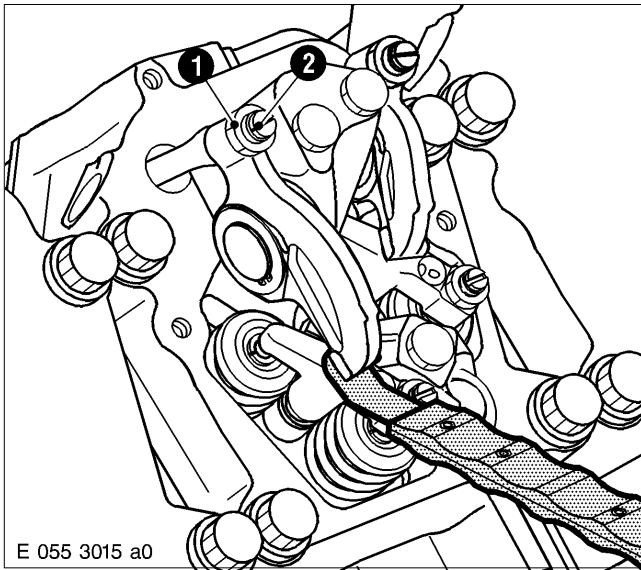

Release locknut (1) and slightly unscrew adjusting screw (2).
 Insert feeler gauge between valve bridge and rocker arm.
 For specified valve clearance – see A 004.
 Set adjusting screw so that the feeler gauge can just be pulled through when locknut is tightened.
 Tighten locknut to specified tightening torque – see C 055.05.01; when doing this, hold adjusting screw in position with a screwdriver.
 Recheck valve clearance after locking nut.

Note: Remove barring tool before starting the engine and mount end cover.

C 055.05.12 After-Installation Operations

A distinction must be made as to whether:

- 1 ————— The engine is to be completely disassembled
- 2 ————— The engine is to be removed but not disassembled
- 3 ————— The engine is to remain installed

1	2	3	Operations	See
x	–	–	Perform operations as per Assembly Plan	B 005
x	–	–	Install engine	B 007
–	x	x	Install cylinder head cover	C 055.10
–	–	x	Release engine start	Operating Instructions

C 055.10 Cylinder Head Cover

C 055.10.01 General View

Cylinder head cover arrangement

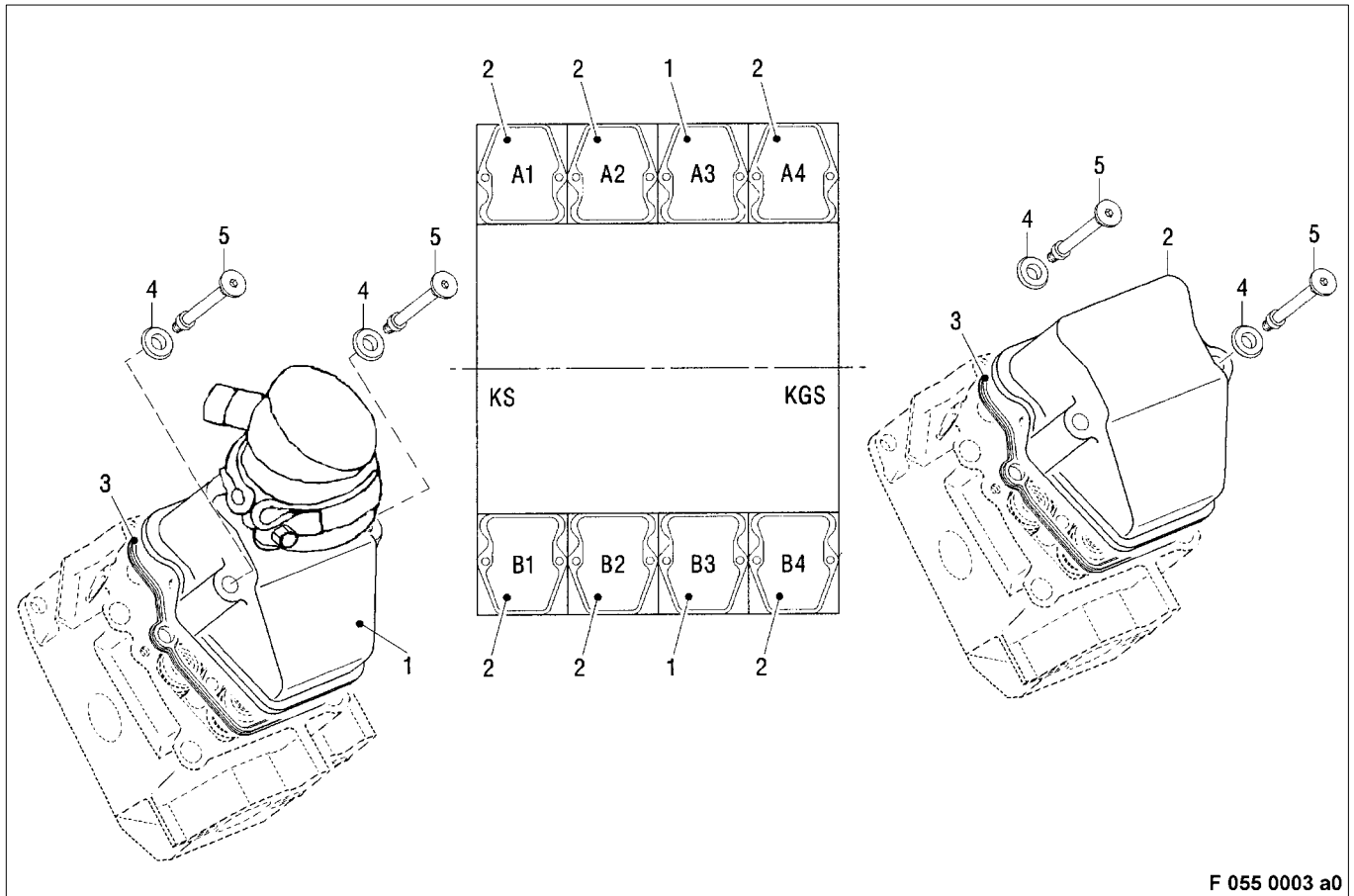

F 055 0003 a0

- 1 Cylinder head cover with oil separator
- 2 Cylinder head cover
- 3 Gasket

- 4 Sealing washer
 - 5 Collar screw
- Tightening torque: 20 Nm
Lubricant: Engine oil

C 055.10.04 Before-Removal Operations

A distinction must be made as to whether:

- 1 — The engine is to be completely disassembled
- 2 — The engine is to be removed but not disassembled
- 3 — The engine is to remain installed

1	2	3	Operations	See
x	—	—	Remove engine	B 003
x	—	—	Perform operations as per Disassembly Plan	B 004
—	—	x	Disable engine start	Operating Instructions
—	x	x	Remove intake hose from oil separator (if necessary)	—
—	x	x	Remove air supply system before turbocharger (if necessary)	—

C 055.10.05 Removal

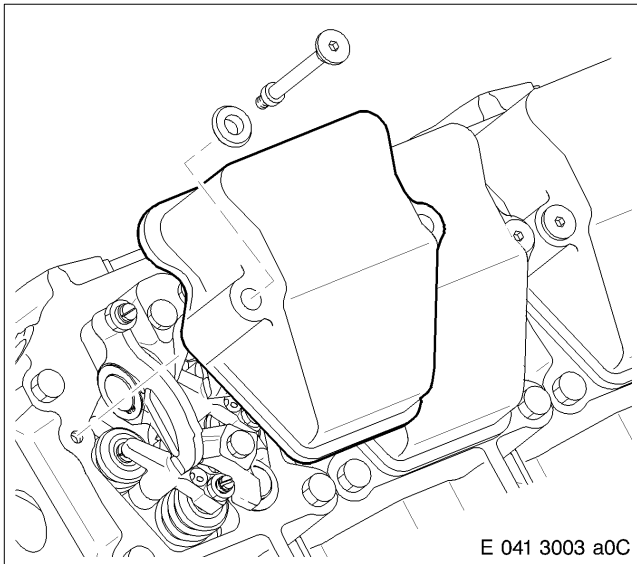

Removing cylinder head cover
 Remove both collar screws.
 Remove cylinder head cover and gasket.

C 055.10.08 Inspection and Repair

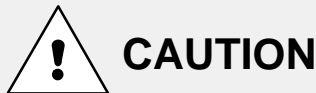

Compressed air is air which has been compressed under pressure. If compressed air is used for blowing out or blow-drying components, always wear protective goggles or safety mask. Compressed air must not be directed at the body. Pressure must not exceed 3.0 bar (40 lb/in²).

Clean cylinder head cover with cleaner, blow out with compressed air and make sure it is perfectly clean.
 Make visible inspection of cylinder head cover for wear and damage paying particular attention to the mating and sealing surfaces; rub down with emery cloth or an oilstone or replace cylinder head cover as necessary.
 Clean collar screws and check for wear and damage; replace if necessary.
 Check thread of collar screws for ease of movement; replace collar screw if necessary.
 Replace gaskets and sealing washers during W6 overhaul.

C 055.10.11 Installation

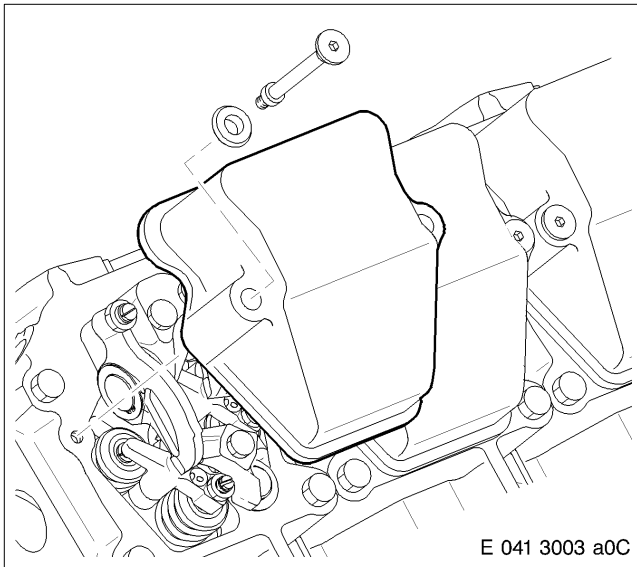

Installing cylinder head cover

Note: Make sure parts are perfectly clean.

Check mounting surface, clean if necessary.

Insert gasket into cylinder head cover.

Fit cylinder head cover on cylinder head.

Install screws with new sealing washers and tighten to specified tightening torque – see C 055.10.01.

C 055.10.12 After-Installation Operations

A distinction must be made as to whether:

- 1 — The engine is to be completely disassembled
- 2 — The engine is to be removed but not disassembled
- 3 — The engine is to remain installed

1	2	3	Operations	See
x	–	–	Perform operations as per Assembly Plan	B 005
x	–	–	Install engine	B 007
–	x	x	Fit intake hose to oil separator	–
–	x	x	Install air pipework before exhaust turbocharger	–
–	–	x	Release engine start	Operating Instructions



Contents

C 070 Fuel System – High-Pressure

C 073.05 Fuel injection pump

- C 073.05.01 General view
- C 073.05.02 Special tool
- C 073.05.04 Before-removal operations
- C 073.05.05 Removal
- C 073.05.06 Disassembly
- C 073.05.08 Inspection and repair
- C 073.05.11 Installation
- C 073.05.12 After-installation operations

C 075.05 Fuel injector and injection line

- C 075.05.01 General view
- C 075.05.02 Special tool
- C 075.05.04 Before-removal operations
- C 075.05.05 Removal
- C 075.05.06 Disassembly
- C 075.05.08 Inspection and repair
- C 075.05.10 Assembly
- C 075.05.11 Installation
- C 075.05.12 After-installation operations

C 070 Fuel System – High-Pressure

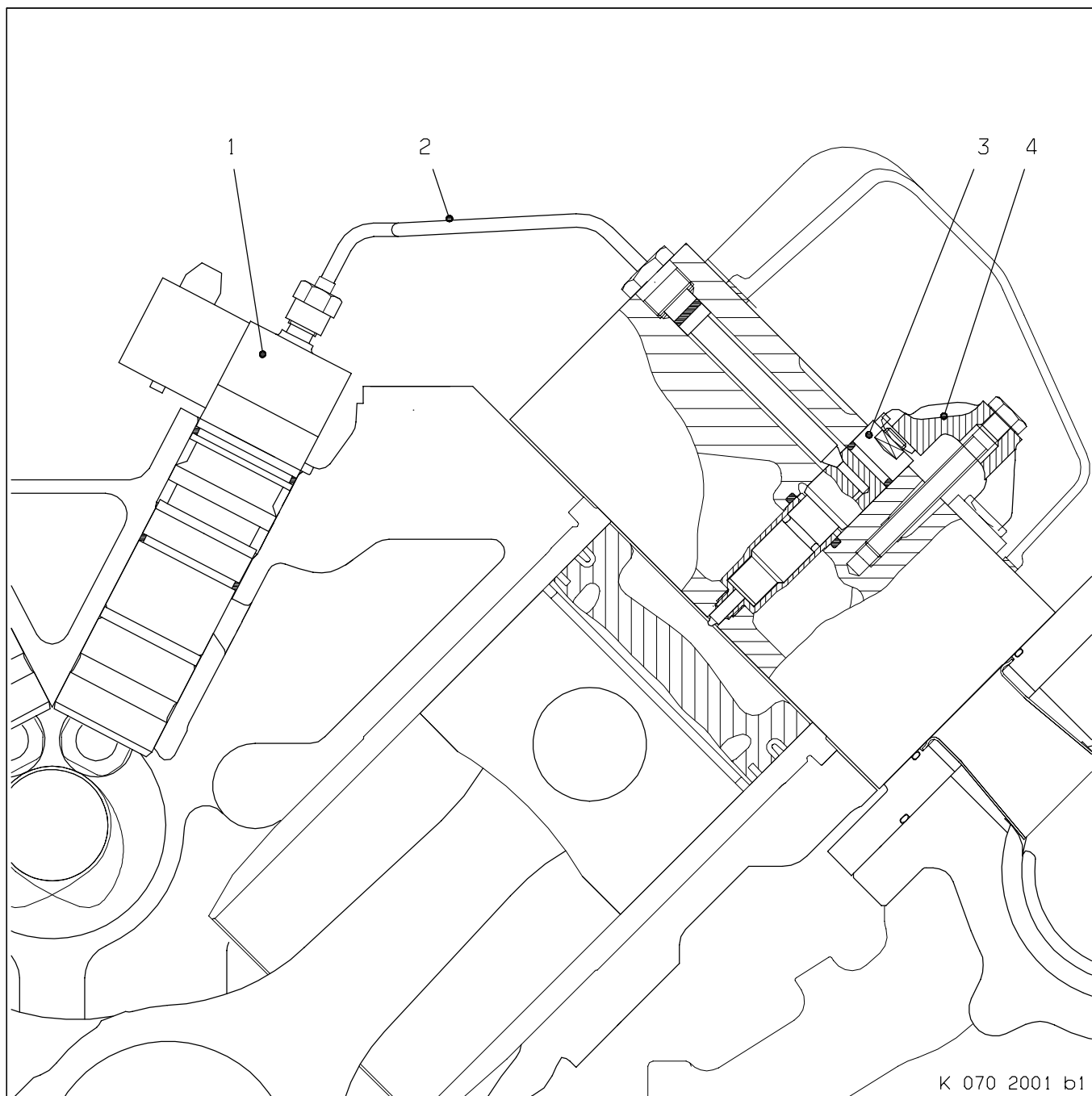

- 1 Plug-in pump
- 2 H.P. line
- 3 Injector
- 4 Clamping element

The following is a list of auxiliary equipment and materials needed for the assembly operations:

CAUTION

When using these miscellaneous materials, it is essential to observe the Manufacturer's Instructions for use, safety instructions and waste disposal specifications.

Materials and consumables	Designation	Order No.		Remarks
		MTU	DDC	
Bottle brush				
Magnifying glass				
Vaseline	Petroleum jelly, white	40317		
Engine oil				
Multipurpose grease	Shell Retinax A	40333		
Kerosene or diesel fuel				
Cleaning agent	Solvclean KW	40022		
Corrosion preventive	Caramba Express	40008		
Engineer's blue	blue	40641		
Dry compressed air				
Magnetic crack-testing equipment with fluorescent magnetic powder				



C 073.05 Fuel Injection Pump

C 073.05.01 General View

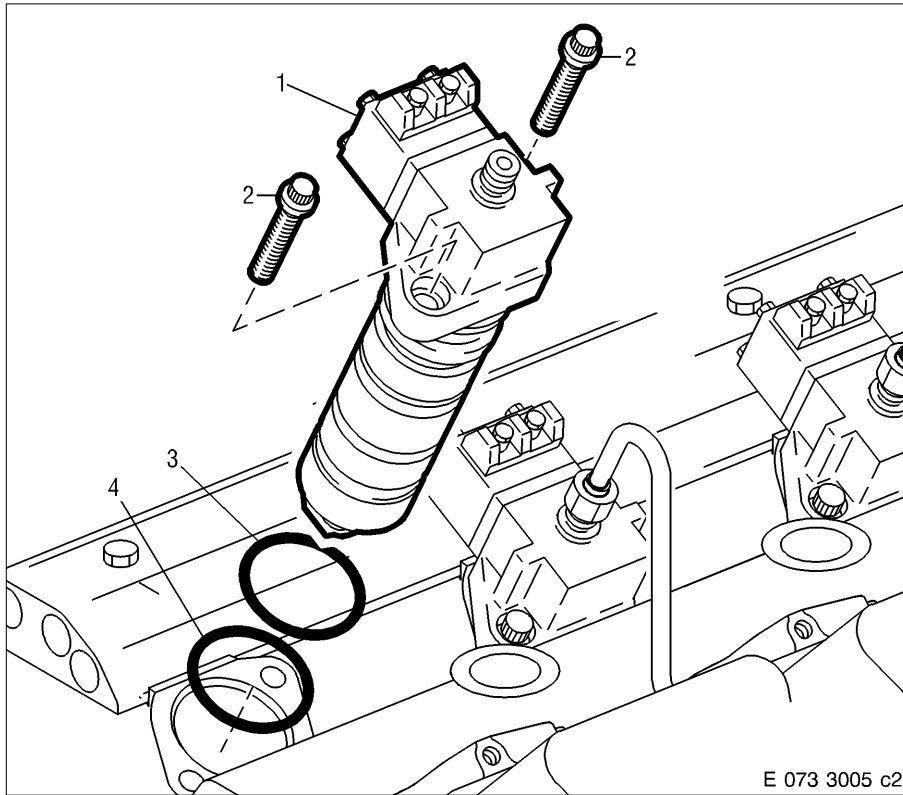

- 1 Plug-in pump
- 2 Double-hex screw
Tightening torque: 60 Nm + 12 Nm
Lubricant: Engine oil
- 3 O-ring
- 4 O-ring

C 073.05.02 Special Tool

Designation – Application	Number
Socket for double-hex screw	1
Barring tool	1

C 073.05.04 Before-Removal Operations

A distinction must be made as to whether:

- 1 — The engine is to be completely disassembled
- 2 — The engine is to be removed but not disassembled
- 3 — The engine is to remain installed

1	2	3	Operations	See
x	—	—	Remove engine	B 003
x	—	—	Perform operations as per Disassembly Plan	B 004
—	—	x	Disable engine start	Operating Instructions
—	x	x	Remove crankcase breather	C 018.10
—	x	x	Disconnect electric wiring	—
—	x	x	Remove ECU housing and bracket	Special Publication
—	x	x	Remove charge air manifold	C 124.05
—	x	x	Remove H.P. line	C 075.05
—	x	x	Release screws for plug-in clips on solenoid valve and separate plug-in clips.	—

C 073.05.05 Removal

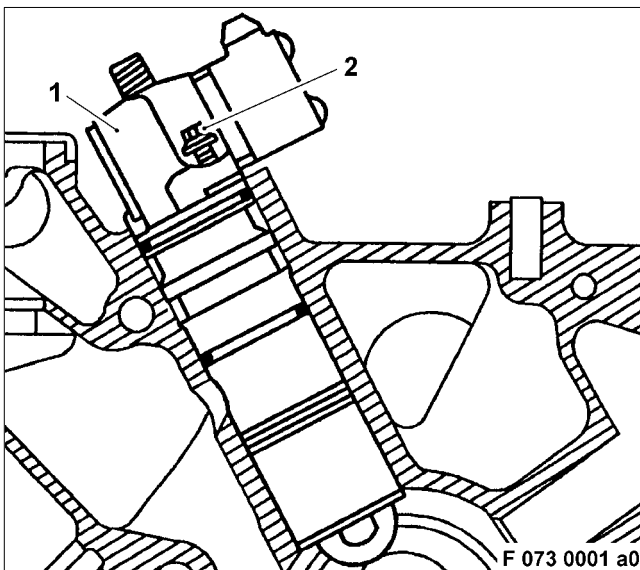

Remove fuel injection pump

WARNING

Fuels and fuel vapours are inflammable and poisonous. Risk of fire, explosion and poisoning!
When handling fuel:
 – do not use naked flame, – no electric sparks,
 – do not smoke, – do not spill fuel. Do not inhale.
Always wear protective gloves and protective goggles/safety mask. Ventilate working area well.

Mark injection pump (1) in accordance with installation location.

Using socket and extension, remove double-hex screws (2) of injection pump approx. 6 mm.

If the injection pump is not already pressed out of the crankcase by means of the preloaded compression spring, bar the engine with the engine barring tool until the injection pump is lifted by the pump cams.

Note: A firmly-seated injection pump must not be pressed out at the solenoid valve or intermediate plate!

If necessary, carefully press out injection pump at recess in injection pump head.

Remove double-hex screws and injection pump.

Remove O-rings from injection pump.

Seal installation bore if necessary.

C 073.05.06 Disassembly

Injection pump must not be disassembled.

C 073.05.08 Inspection and Repair

Check injection pump in a specialist workshop or at Manufacturer's; have repaired if necessary.



CAUTION

Compressed air is air which has been compressed under pressure. If compressed air is used for blowing out or blow-drying components, always wear protective goggles or safety mask. Compressed air must not be directed at the body. Pressure must not exceed 3.0 bar (40 lb/in²).

Clean injection pump with cleaner, blow out with compressed air and make sure it is perfectly clean.

Make visible inspection of injection pump for wear and damage paying particular attention to the running surface of the roller; replace injection pump if it is worn or damaged.

Clean double-hex screws and check condition of screws.

Make sure threads are in perfect condition; replace double hex screws as necessary.

Check condition of wiring; replace if necessary.

Replace O-rings every time pump is assembled.

C 073.05.11 Installation

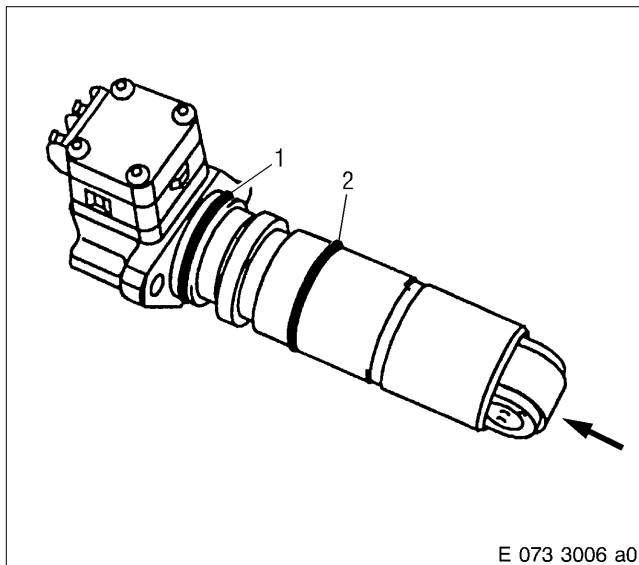

Installing injection pump

Note: Make sure parts are perfectly clean.

Coat both O-rings (1) and (2) with petroleum jelly and fit on injection pump.

Note: O-rings have different item numbers. Make sure that installation position is correct.

Coat roller (arrow) of injection pump with engine oil.

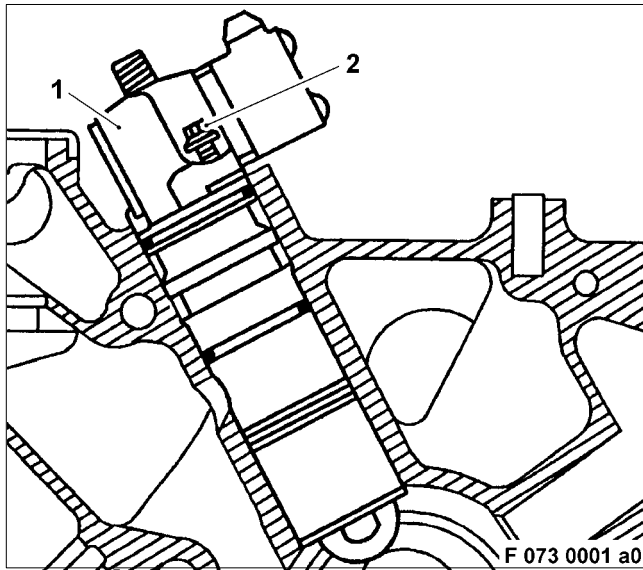

Note: Before installing, remove all blanking plugs and covers.

Check that sealing surfaces and fuel bores in the crankcase are perfectly clean; clean if necessary.

Using the engine barring tool, set pump cams of camshaft to base circle.

Arrange injection pump (1) with respect to installation location and manually press into crankcase against spring power (distance approx. 4 mm).

Note: If a new injection pump is installed, coding must be entered into the engine control system – see DCC or MTU Elektronik Documentation.

Insert both double-hex screws (2) with socket and extension uniformly and tighten to specified tightening torque – see C 073.05.01.

Attach plug-in clip of wiring to solenoid valve and tighten screws to specified tightening torque – see A 003.

C 073.05.12 After-Installation Operations

A distinction must be made as to whether:

- 1 ————— The engine is to be completely disassembled
- 2 ————— The engine is to be removed but not disassembled
- 3 ————— The engine is to remain installed

1	2	3	Operations	See
x	–	–	Perform operations as per Assembly Plan	B 005
x	–	–	Install engine	B 007
–	x	x	Install H.P. line	C 075.05
–	x	x	Install charge air manifold	C 124.05
–	x	x	Install crankcase breather	C 018.10
–	x	x	Install bracket and ECU housing	Special Publication
–	x	x	Connect electric cables	–
–	–	x	Release engine start	Operating Instructions

C 075.05 Fuel Injector, Injection Line

C 075.05.01 General View

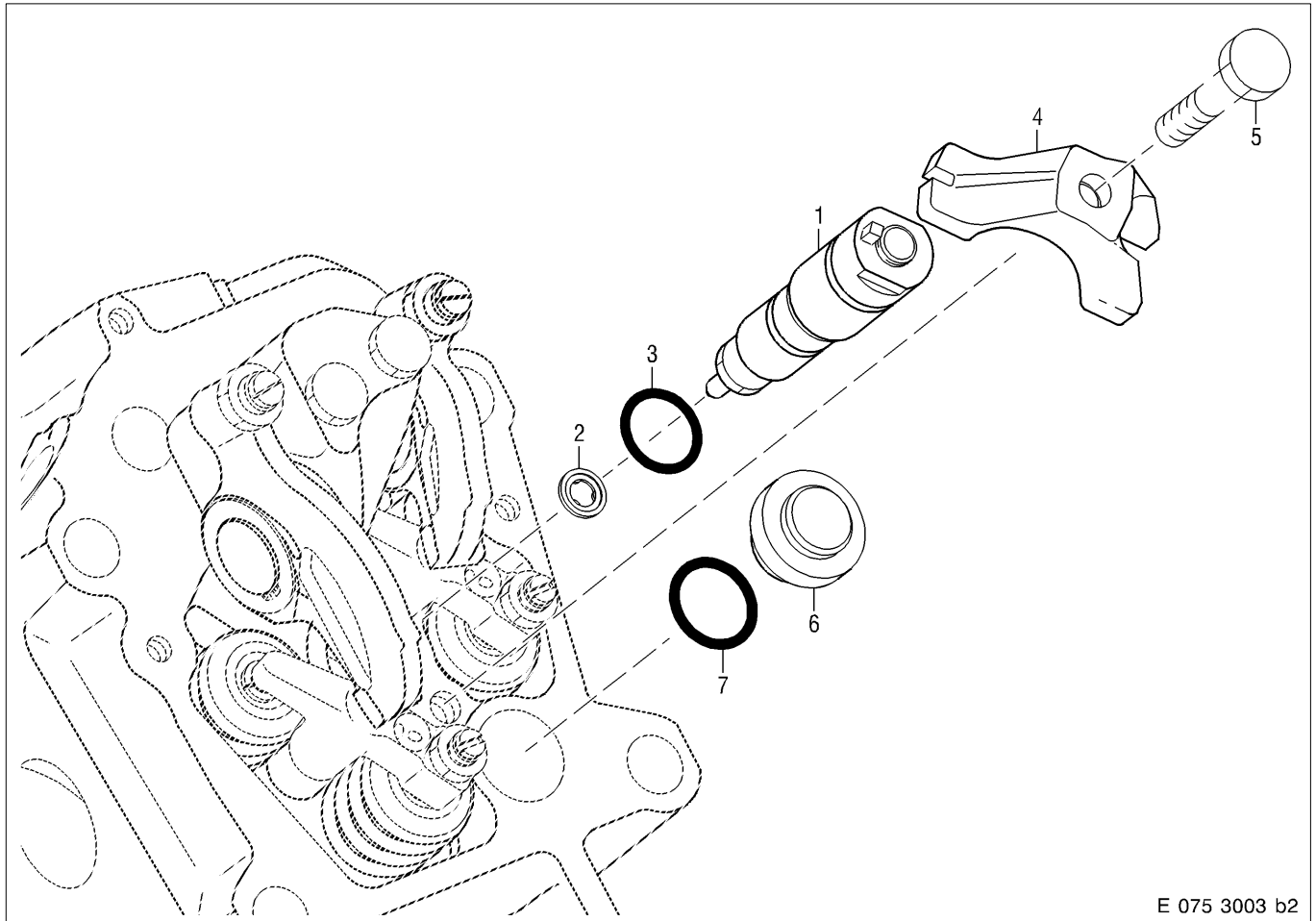

E 075 3003 b2

- 1 Injector
- 2 Sealing ring
- 3 O-ring
- 4 Clamping element

- 5 Hex screw
Tightening torque: 50 Nm
Lubricant: Engine oil
- 6 End cover
- 7 Sealing ring

Injection line

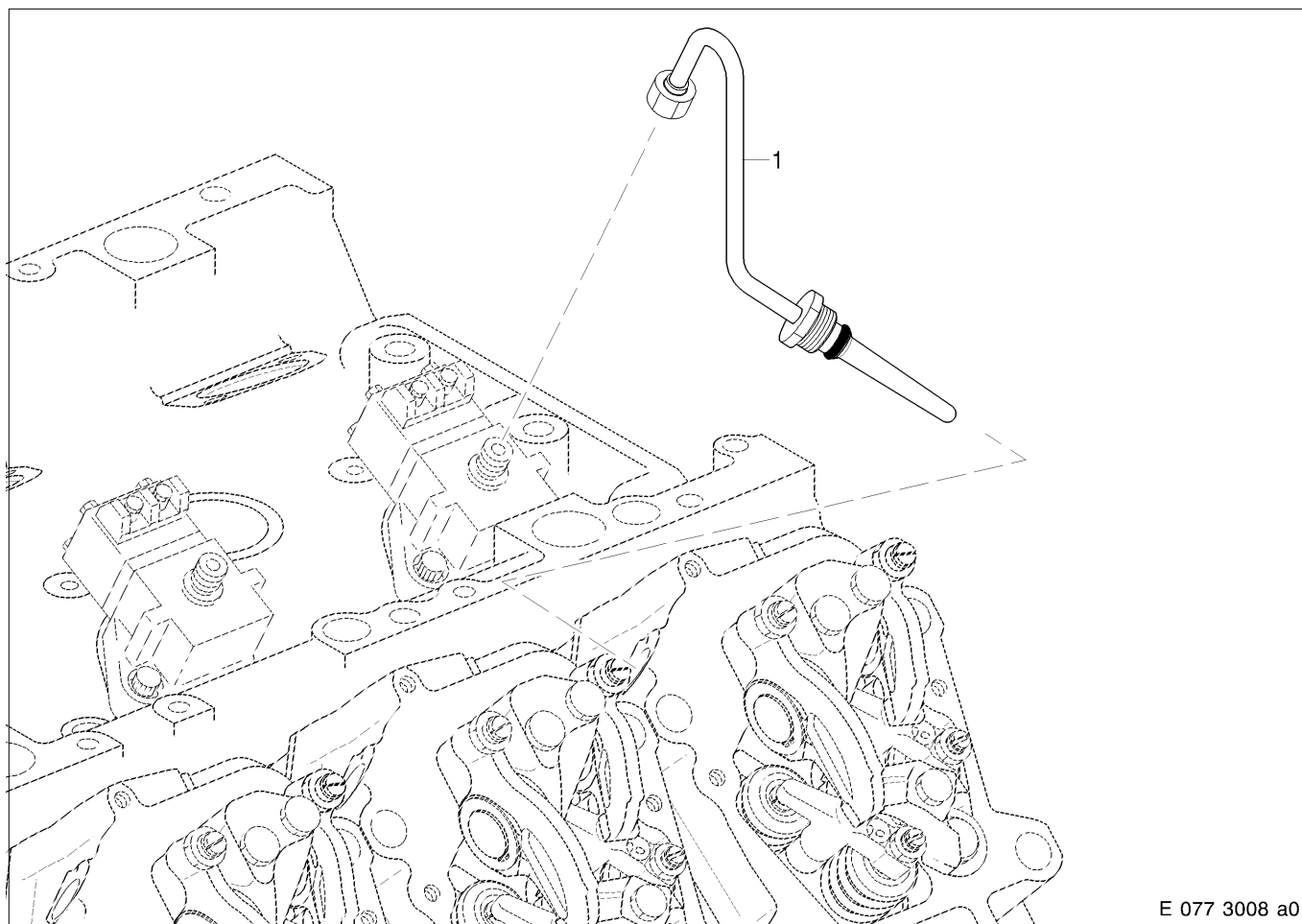

E 077 3008 a0

- 1 H.P. line
- Union nut on injection pump:
Tightening torque: 25 Nm + 2 Nm
- Adapter in cylinder head:
Tightening torque: 40 Nm
- Lubricant: Engine oil

C 075.05.02 Special Tool

Designation – Application	Number
Ring wrench insert for union nuts	1
Ring wrench insert for thrust screw	1
Fuel suction lift	1
Removal tool for injector	1

C 075.05.04 Before-Removal Operations

A distinction must be made as to whether:

- 1 ————— The engine is to be completely disassembled
- 2 ————— The engine is to be removed but not disassembled
- 3 ————— The engine is to remain installed

1	2	3	Operations	See
x	–	–	Remove engine	B 003
x	–	–	Perform operations as per Disassembly Plan	B 004
–	–	x	Disable engine start	Operating Instructions
–	x	x	Remove oil separator (if necessary)	C 018.10
–	x	x	Remove cylinder head cover	C 055.10

C 075.05.05 Removal

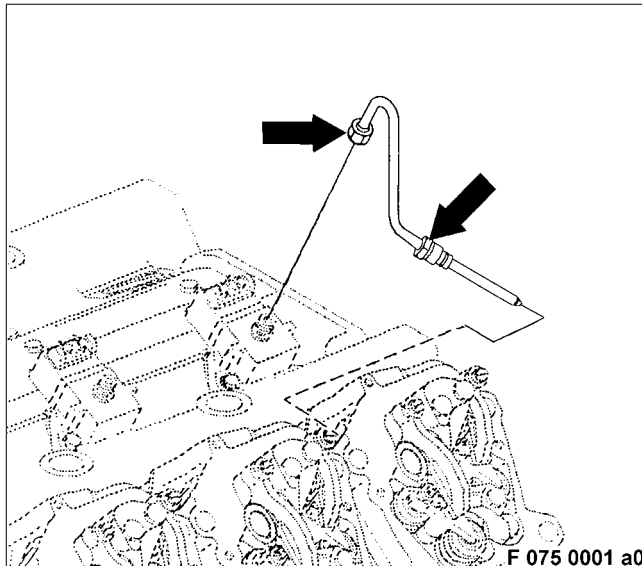

Removing H.P. fuel lines and fuel injectors

! WARNING

Fuels and fuel vapours are inflammable and poisonous. Risk of fire, explosion and poisoning!

When handling fuel:

- do not use naked flame, – no electric sparks,
- do not smoke, – do not spill fuel. Do not inhale.

Always wear protective gloves and protective goggles/safety mask. Ventilate working area well.

Remove union nut and adapter (arrow).
 Withdraw H.P. line from cylinder head.
 Using a sprayer and rubber hose, drain fuel in the two free bores.

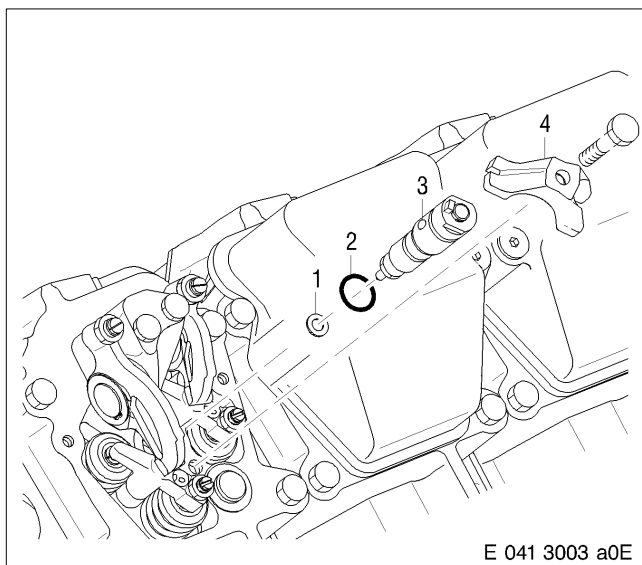

Withdraw hex screw and remove clamping element (4).
 Install removal tool for injector on female thread of injector (3) and remove injector.
 Remove copper ring (1) with a wire hook.
 Remove O-ring (2) from injector.
 Cover all connections and installation bores or seal with suitable plugs.

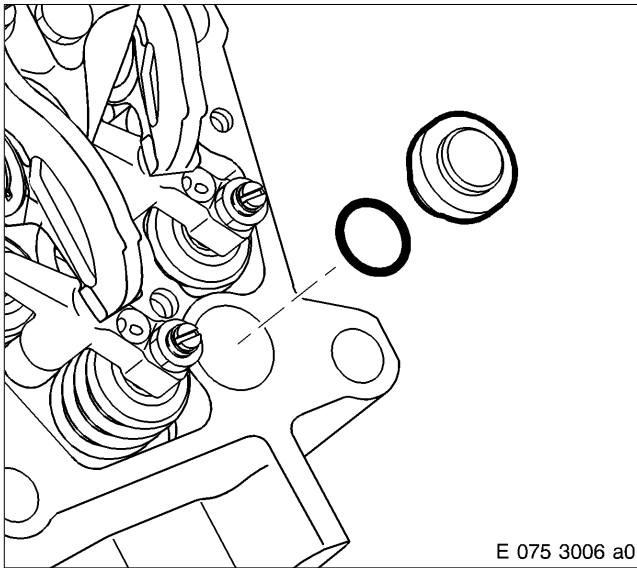

Removing end cover for clamping element in cylinder head

Using a screw driver, carefully remove end cover from cylinder head.

Remove sealing ring.

C 075.05.06 Disassembly

For injector disassembly, see Operating Instructions

C 075.05.07 Inspection and Repair

Note: Make sure fuel-carrying components are perfectly clean.

For instructions on inspecting and repairing fuel injector, see Engine Operation Manual.

Clean all components with cleaner and visually inspect for condition and damage; replace component as necessary.



CAUTION

Compressed air is air which has been compressed under pressure. If compressed air is used for blowing out or blow-drying components, always wear protective goggles or safety mask. Compressed air must not be directed at the body. Pressure must not exceed 3.0 bar (40 lb/in²).

Blow out H.P. line with compressed air and make sure it is perfectly clean.

Using the magnetic crack-testing method with fluorescent magnetic powder, check hex screw and clamping element for cracks; replace components as necessary.

Check seating faces of clamping element and end cover; if necessary rub down with an oilstone or emery cloth. Replace components as necessary.

Check hex screws for damage and check threads for ease of movement; replace hex screw if necessary.

Check sealing cones and threads on H.P. fuel line for damage and wear; replace H.P. fuel line if necessary.

Note: Do not bend the H.P. line!

Replace sealing rings and O-rings at every assembly.

C 075.05.10 Assembly

For injector assembly, see Operating Instructions.

C 075.05.11 Installation

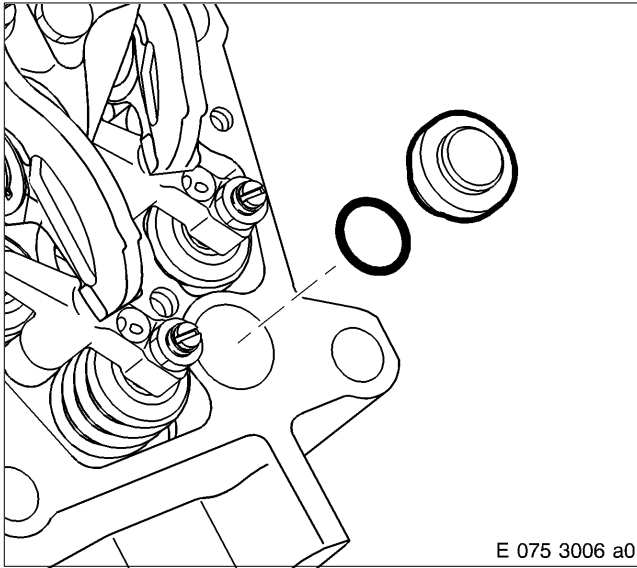

Installing end cover for clamping element in cylinder head

Coat sealing ring with petroleum jelly and insert in groove on end cover.

Insert end cover into bore in cylinder head.

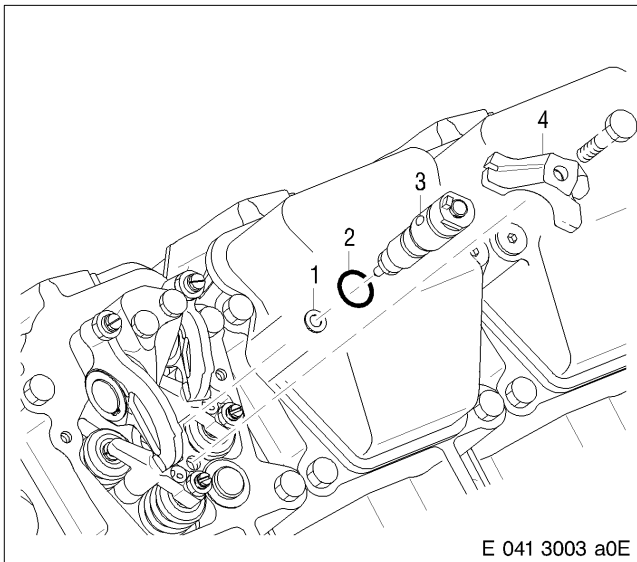

Installing fuel injectors and injection lines

Note: Make sure fuel-carrying components are perfectly clean. Before installing, remove all blanking plugs and covers.

! WARNING

Fuels and fuel vapours are inflammable and poisonous. Risk of fire, explosion and poisoning!
When handling fuel:
– do not use naked flame, – no electric sparks,
– do not smoke, – do not spill fuel. Do not inhale.
Always wear protective gloves and protective goggles/safety mask. Ventilate working area well.

Bar engine several times to blow out any remaining fuel.

Check sealing surface on cylinder head and nozzle holder; clean if necessary.

Coat new O-ring (2) with petroleum jelly and fit on injector (3).

Attach sealing ring (1) with grease to injector.

Insert injector into cylinder head, ensuring that direction of installation is correct, see next illustration.

Positioning correctly, install clamping element (4) with hex screw.

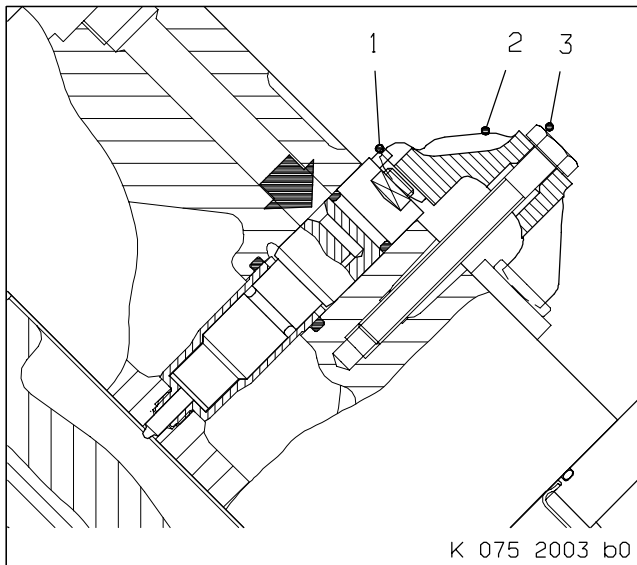

The injector supply bore must point in the installation direction (arrow) of the H.P. fuel line.
 Pin (1) in injector must be located in clamping element (2) recess.
 Tighten hex screw (3) hand tight and then slacken by one revolution.

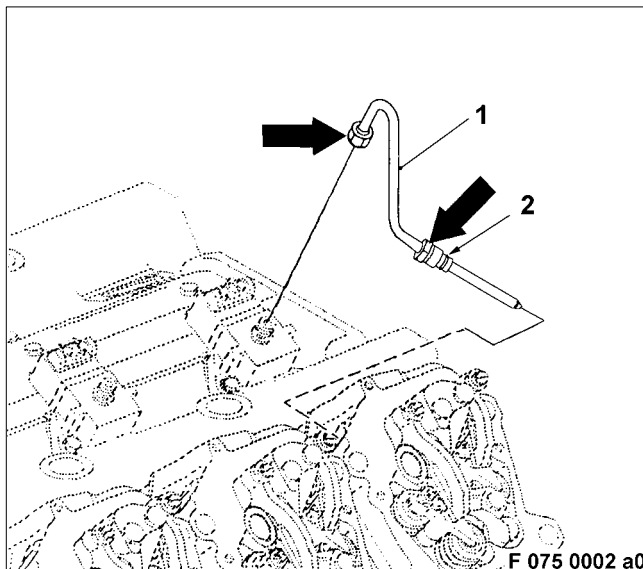

Coat O-ring (2) in H.P. fuel line with petroleum jelly.
 Insert H.P. line into cylinder head, screw union nut and adapter (arrow) into position but do not tighten!
 Align injector in such a way that the H.P. line is correctly positioned in connecting taper.
 Tighten hex bolt for clamping element to specified tightening torque – see C 075.05.01.
 Tighten union nut and adapter in the H.P. line to specified tightening torque – see C 075.05.01.
Note: After engine start, visually inspect fuel system for leaks.

C 075.05.12 After-Installation Operations

A distinction must be made as to whether:

- 1 ————— The engine is to be completely disassembled
- 2 ————— The engine is to be removed but not disassembled
- 3 ————— The engine is to remain installed

1	2	3	Operations	See
x	–	–	Perform operations as per Assembly Plan	B 005
x	–	–	Install engine	B 007
–	x	x	Install cylinder head cover	C 055.10
–	x	x	Install oil separator	C 018.10
–	–	x	Release engine start	Operating Instructions

Contents

C 080	Fuel System – Low Pressure
C 080.08	Pressure testing fuel system
C 081.05	Fuel lines before fuel pump, fuel pump
C 081.05.01	General view
C 081.05.02	Special tool
C 081.05.04	Before-removal operations
C 081.05.05	Removal
C 081.05.06	Disassembly
C 081.05.08	Inspection and repair
C 081.05.11	Installation
C 081.05.12	After-installation operations
C 082.05	Fuel line from pump to filter
C 082.05.01	General view
C 082.05.04	Before-removal operations
C 082.05.05	Removal
C 082.05.08	Inspection and repair
C 082.05.11	Installation
C 082.05.12	After-installation operations
C 083.05	Fuel filter
C 083.05.01	General view
C 083.05.02	Special tool
C 083.05.04	Before-removal operations
C 083.05.05	Removal
C 083.05.08	Inspection and repair
C 083.05.11	Installation
C 083.05.12	After-installation operations
C 084.05	Fuel line from filter to injection pump
C 084.05.01	General view
C 084.05.04	Before-removal operations
C 084.05.05	Removal
C 084.05.06	Disassembly
C 084.05.08	Inspection and repair
C 084.05.10	Assembly
C 084.05.11	Installation
C 084.05.12	After-installation operations

C 086.05 Leak-off fuel line

- C 086.05.01 General view
- C 086.05.04 Before-removal operations
- C 086.05.05 Removal
- C 086.05.08 Inspection and repair
- C 086.05.11 Installation
- C 086.05.12 After-installation operations

C 080 Fuel System – Low Pressure

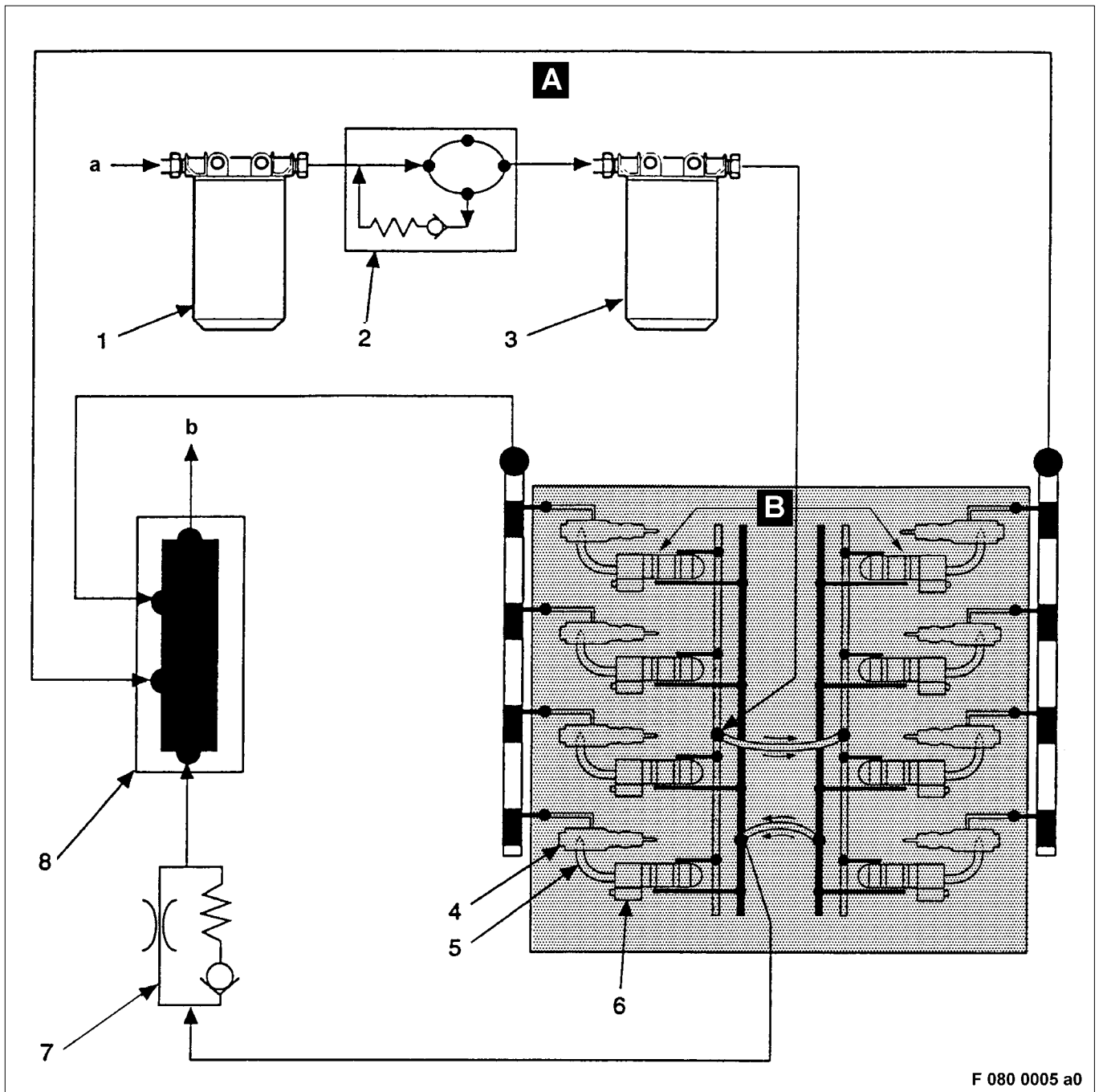

F 080 0005 a0

- | | | |
|---------------|-----------------------------|-------------------------------|
| 1 Fuel filter | 5 H.P. line | A Fuel system (low pressure) |
| 2 Fuel pump | 6 Injection pump | B Fuel system (high pressure) |
| 3 Fuel filter | 7 Pressure regulating valve | a from fuel tank |
| 4 Injector | 8 Junction box | b to fuel tank |

The following is a list of auxiliary equipment and materials needed for the assembly operations:

!	CAUTION
When using these chemical substances, it is essential to observe the Manufacturer's Instructions for use, safety instructions and waste disposal specifications.	

Materials and consumables	Designation	Order No.		Remarks
		MTU	DDC	
Emery cloth				
Wire brush				
Magnifying glass				
Vaseline	Petroleum jelly, white	40317		
Engine oil				
Multipurpose grease	Shell Retinax A	40333		
Cleaning agent	Solvclean KW	40022		
Kerosene or diesel fuel				
Thread-sealing compound	Loctite No. 586	40033		Final strength at 20 °C – 12 h
Activator	Loctite No. 7649	50548		
Ethanol, denaturated		40250		
Corrosion preventive	Caramba Express	40008		
Dry compressed air				
Surface crack-testing equipment with red penetrant dye				

C080.08 Pressure Testing Fuel System

Note: After the engine has been assembled, the fuel system is pressure tested with compressed air, or checked for leakages.



WARNING

**Only use hydraulic pressure testing device specified by the manufacturer.
Observe specified safety and accident prevention regulations!**

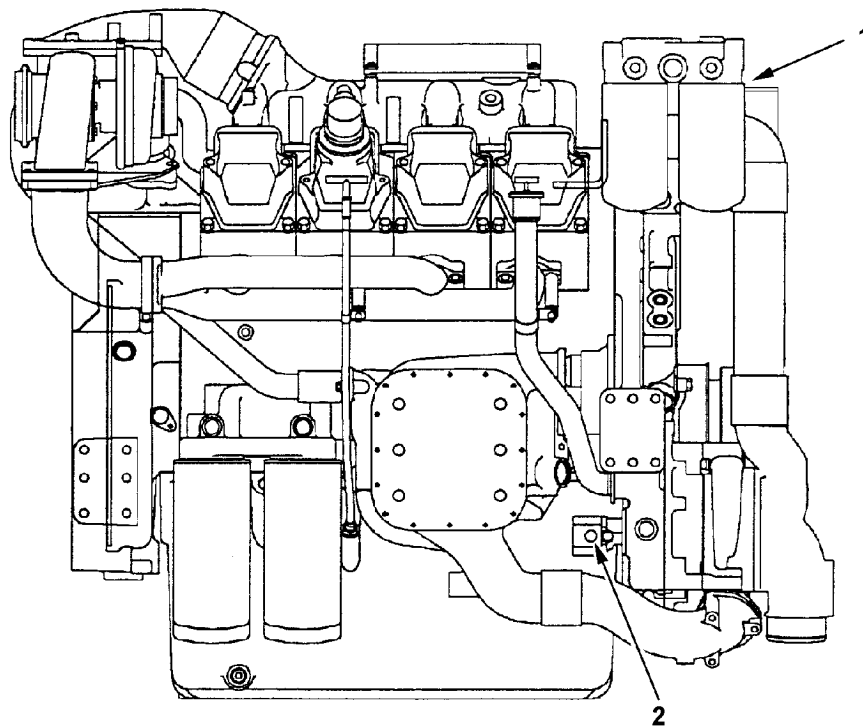

F 080 0007 a0

Seal adapter on distributor housing (1), see C 084.05.

Connect compressed air supply line of the hydraulic testing device to the fuel supply delivery pump (2).



WARNING

**Compressed air is air which has been compressed under pressure. Risk of injury. Test pressure must not be exceeded.
Always wear protective clothing, protective gloves and protective goggles/safety mask.**

Hydraulically pressure test fuel system with compressed air and check for leakages.

Filling pressure = 0.6895 bar (10 psi)

Filling time = 75 s

Max. leak-off rate = 20 cm³/min

Test time = 75 s

If the max. leak-off rate is exceeded, determine cause and rectify.

C081.05 Fuel Lines before Fuel Pump, Fuel Pump

C 081.05.01 General View

Fuel lines before fuel delivery pump

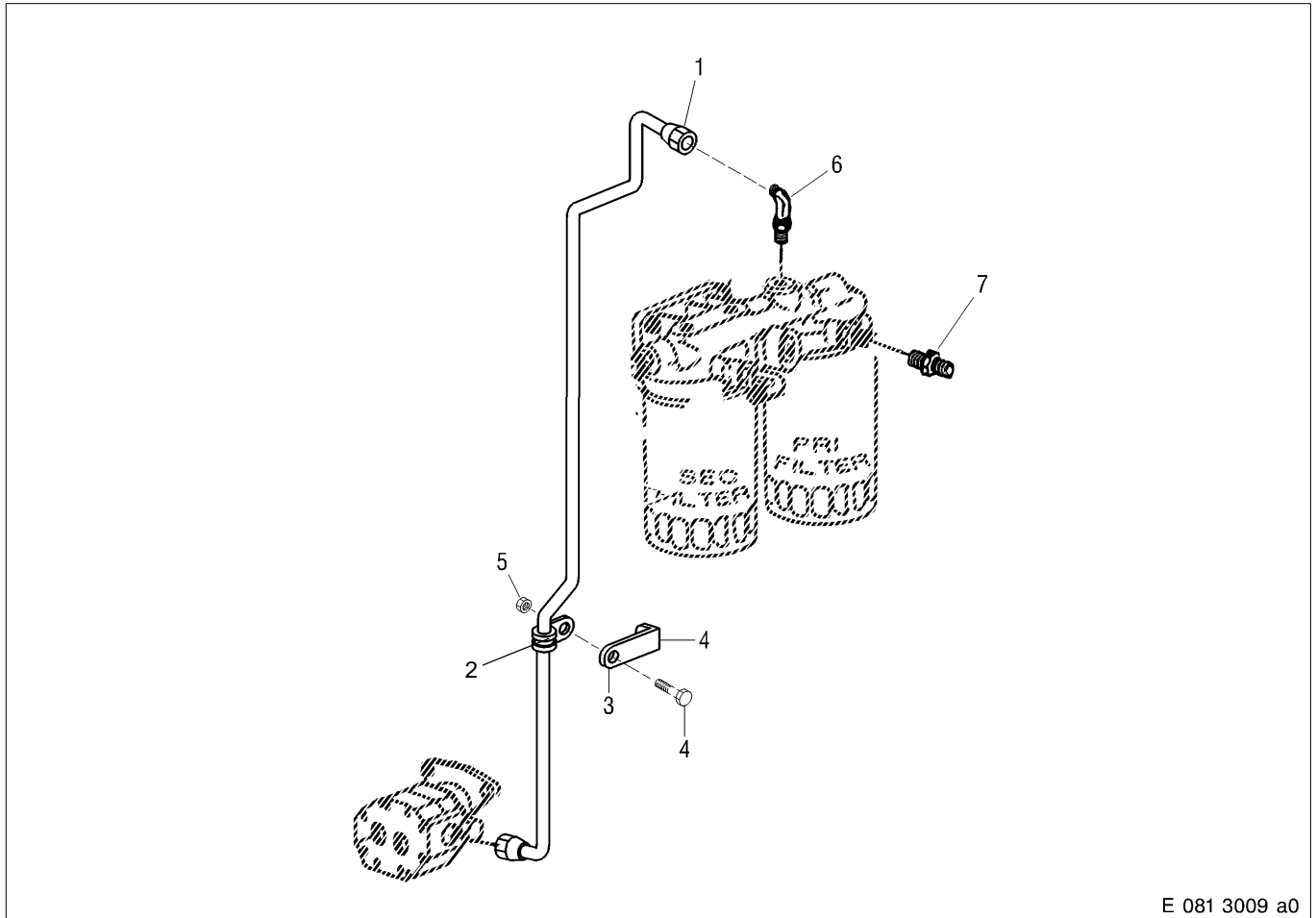

E 081 3009 a0

- | | |
|-------------|---------|
| 1 Fuel line | 5 Nut |
| 2 Clamp | 6 Union |
| 3 Retainer | 7 Union |
| 4 Hex bolt | |

Fuel delivery pump

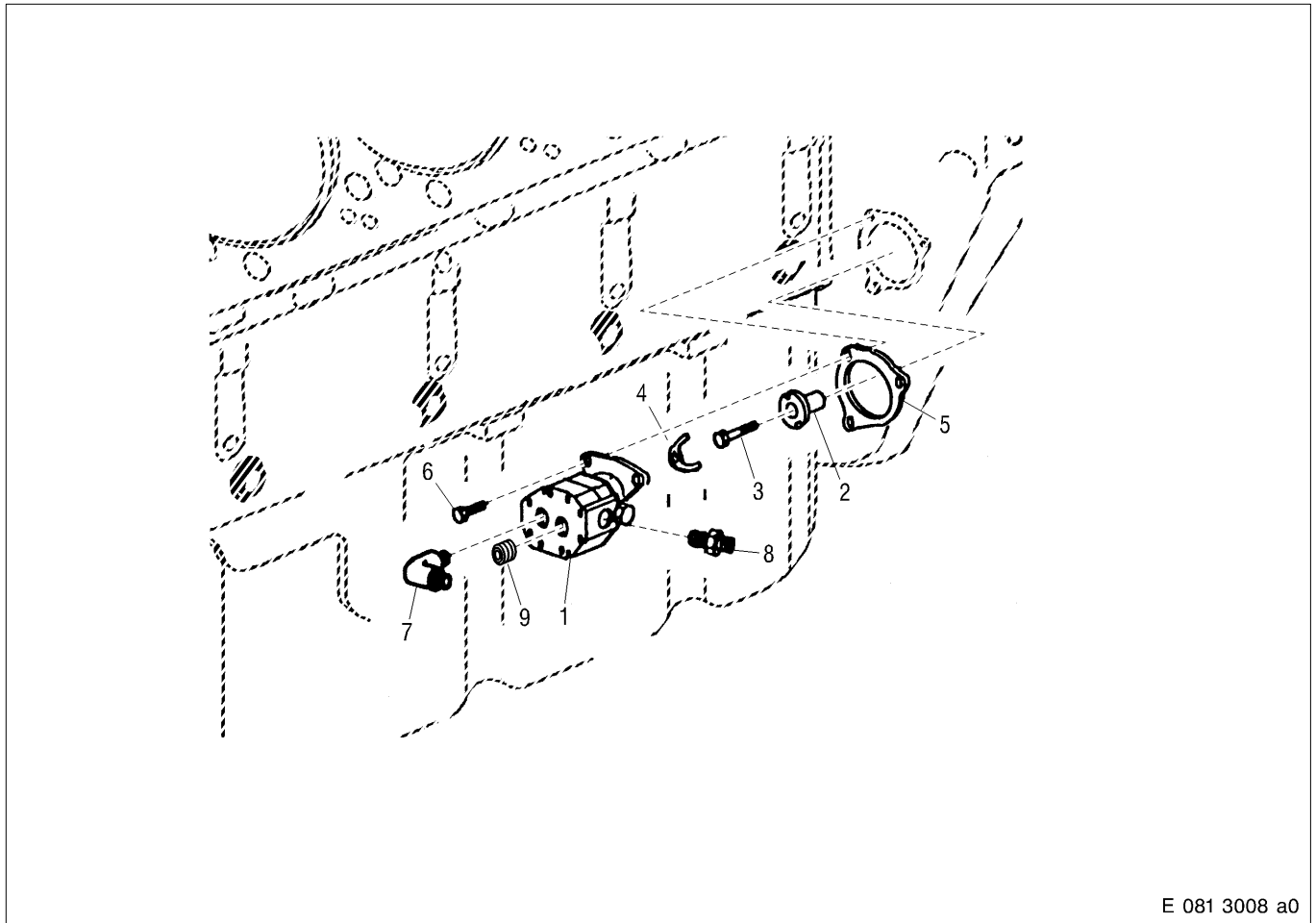

E 081 3008 a0

- | | |
|--------------------------|-------------------|
| 1 Fuel delivery pump | 4 Driver |
| 2 Driver | 5 Gasket |
| 3 Screw | 6 Hex bolt |
| Tightening torque: 55 Nm | 7 Bracket |
| Lubricant: Engine oil | 8 Reduction union |

C 081.05.02 Special Tool

Designation – Application	Number
Starter key, 13x17, for fuel pump	1
Crowfoot wrench 3/8" A/F	1
Extension, bent, 3/8", 150 mm	1

C 081.05.04 Before-Removal Operations

A distinction must be made as to whether:

- 1 ————— The engine is to be completely disassembled
- 2 ————— The engine is to be removed but not disassembled
- 3 ————— The engine is to remain installed

1	2	3	Operations	See
x	-	-	Remove engine	B 003
x	-	-	Perform operations as per Disassembly Plan	B 004
-	-	x	Disable engine start	Operating Instructions

C 081.05.05 Removal

Removing fuel lines before fuel delivery pump

Note: Before removing fuel lines, it is advisable to take photographs of the lines on the engine or to mark the fuel lines with metal tabs to facilitate reinstallation.



WARNING

Fuels and fuel vapours are inflammable and poisonous. Risk of fire, explosion and poisoning! When handling fuel: – do not use naked flame, – no electric sparks, – do not smoke, – do not spill fuel. Do not inhale. Always wear protective gloves and protective goggles/safety mask. Ventilate working area well.

Release fuel line threaded connection and catch fuel emerging in a suitable container.

Remove fuel line and fixtures in accordance with General View, see C 081.05.01.

After removing the fuel line, cover all connections with suitable plugs.

Removing fuel delivery pump

Remove fuel delivery pump from equipment carrier in accordance with General View, see C 081.05.01.

Remove driver from drive shaft of fuel delivery pump.

Remove gasket.

Remove screw from coolant pump shaft and remove driver.

C 081.05.06 Disassembly

Disassembling fuel delivery pump.

Fuel delivery pump must not be disassembled.

C 081.05.08 Inspection and Repair

Note: Make sure fuel-carrying components are perfectly clean.

Fuel delivery pump

Check fuel delivery pump in a specialist workshop or at Manufacturer's; have repaired if necessary.



CAUTION

Compressed air is air which has been compressed under pressure. If compressed air is used for blowing out or blow-drying components, always wear protective goggles or safety mask. Compressed air must not be directed at the body. Pressure must not exceed 3.0 bar (40 lb/in²).

Clean fuel delivery pump with cleaner, blow out with compressed air and make sure it is perfectly clean. Perform external visual inspection of fuel delivery pump for damage and wear; replace as necessary. Check securing screws for damage and check threads for ease of movement; replace screws if necessary. Replace gasket.

Fuel line and securing elements

Clean fuel line with cleaner and visually inspect for condition and damage; replace if necessary.



CAUTION

Compressed air is air which has been compressed under pressure. If compressed air is used for blowing out or blow-drying components, always wear protective goggles or safety mask. Compressed air must not be directed at the body. Pressure must not exceed 3.0 bar (40 lb/in²).

Blow out fuel line with compressed air and make sure it is perfectly clean. Check fuel line with air under water for leakages; replace if it is leaking.



WARNING

Compressed air is air which has been compressed under pressure. Risk of injury. Pressure must not exceed 0.5 bar (7.25 lb/in²). Always wear protective clothing, protective gloves and protective goggles/safety mask.

Coolant temperature: at least 30 °C, whereby the component must also be at this temperature, 40 °C at the most, if the component must sometimes be held in hands.

Test pressure: 0.5 bar

Check threads of union nuts and single-ended unions for ease of movement; recondition or replace part as required.

Check securing elements of fuel line for damage and wear; replace components as necessary.

C 081.05.11 Installation

Note: Make sure fuel-carrying components are perfectly clean.

Installing fuel delivery pump

Install driver with screw to the coolant pump shaft, see C 081.05.01 and tighten to specified tightening torque, see C 202.05.11.

Mount gasket on equipment carrier.

Mount driver on drive shaft of fuel delivery pump in accordance with General View.

Insert fuel delivery pump in equipment carrier and ensure that the driver is securely fitted.

Using hex bolts, tighten fuel delivery pump.

Installing fuel lines before fuel delivery pump

Note: Remove all blanking plug before installation.

CAUTION

Compressed air is air which has been compressed under pressure. If compressed air is used for blowing out or blow-drying components, always wear protective goggles or safety mask. Compressed air must not be directed at the body. Pressure must not exceed 3.0 bar (40 lb/in²).

Blow out fuel line with compressed air and make sure it is perfectly clean.

Install fuel line with securing elements in accordance with General View, see C 081.05.01, or install tension-free as shown in the photo or as per markings.

Note: After engine start, visually inspect fuel system for leaks.

C 081.05.12 After-Installation Operations

A distinction must be made as to whether:

- 1 ————— The engine is to be completely disassembled
- 2 ————— The engine is to be removed but not disassembled
- 3 ————— The engine is to remain installed

1	2	3	Operations	See
x	–	–	Perform operations as per Assembly Plan	B 005
x	–	–	Install engine	B 007
–	–	x	Release engine start	Operating Instructions



C 082.05 Fuel Line from Pump to Filter

C 082.05.01 General View

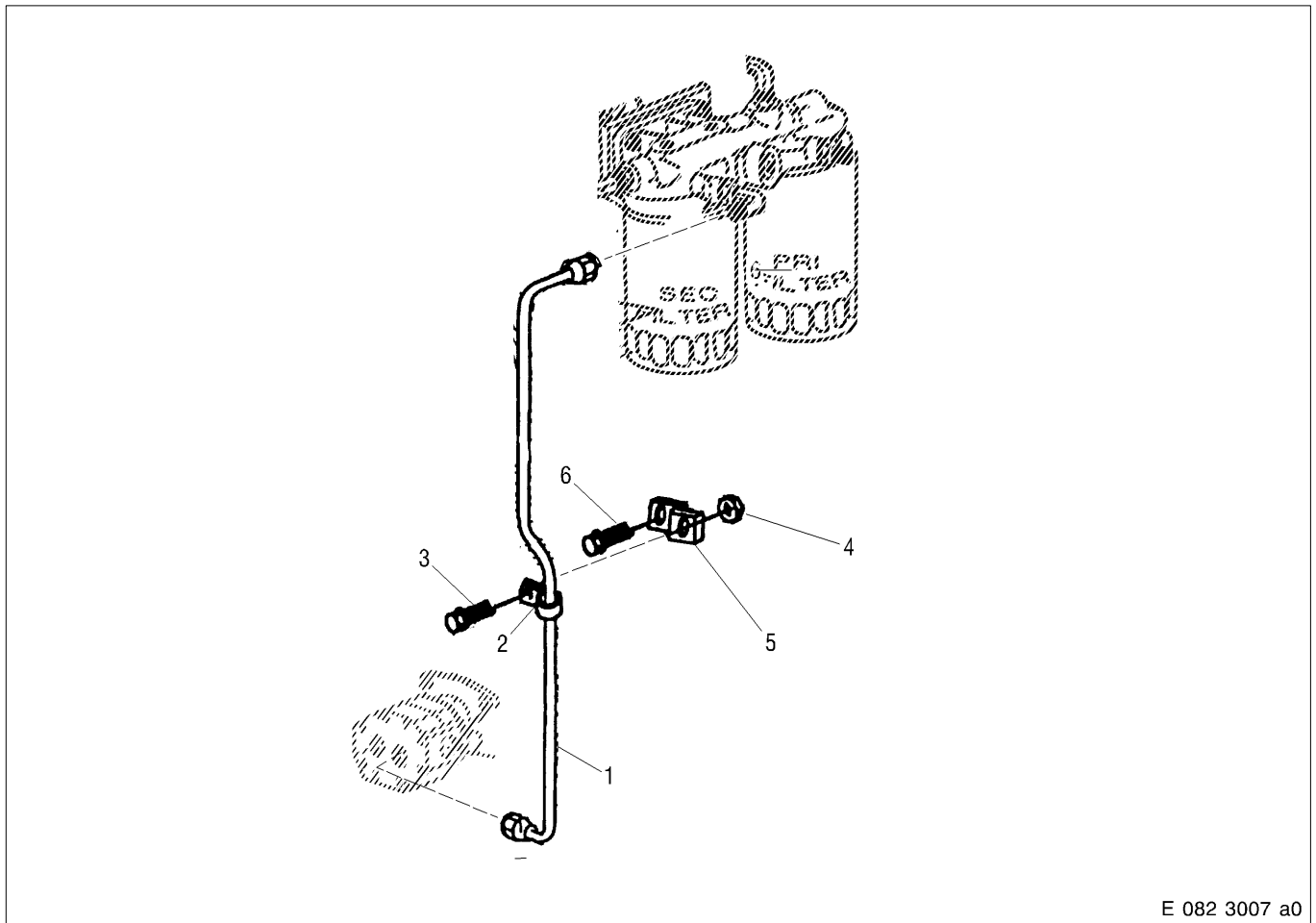

- | | |
|-------------|------------|
| 1 Fuel line | 4 Nut |
| 2 Clamp | 5 Bracket |
| 3 Hex bolt | 6 Hex bolt |

C 082.05.04 Before-Removal Operations

A distinction must be made as to whether:

- 1 ————— The engine is to be completely disassembled
- 2 ————— The engine is to be removed but not disassembled
- 3 ————— The engine is to remain installed

1	2	3	Operations	See
x	-	-	Remove engine	B 003
x	-	-	Perform operations as per Disassembly Plan	B 004
-	-	x	Disable engine start	Operating Instructions

C 082.05.05 Removal

Removing fuel line from pump to filter



WARNING

Fuels and fuel vapours are inflammable and poisonous. Risk of fire, explosion and poisoning! When handling fuel: – do not use naked flame, – no electric sparks, – do not smoke, – do not spill fuel. Do not inhale. Always wear protective gloves and protective goggles/safety mask. Ventilate working area well.

Release fuel line threaded connection and catch fuel emerging in a suitable container.

Remove fuel line and fixtures in accordance with General View, see C 082.05.01.

After removing the fuel line, cover all connections with suitable plugs.

C 082.05.08 Inspection and Repair

Note: Make sure fuel-carrying components are perfectly clean.

Clean fuel line with cleaner and visually inspect for condition and damage; replace if necessary.



CAUTION

Compressed air is air which has been compressed under pressure. If compressed air is used for blowing out or blow-drying components, always wear protective goggles or safety mask. Compressed air must not be directed at the body. Pressure must not exceed 3.0 bar (40 lb/in²).

Blow out fuel line with compressed air and make sure it is perfectly clean.

Check fuel line with air under water for leakages; replace if it is leaking.



WARNING

Compressed air is air which has been compressed under pressure. Risk of injury. Pressure must not exceed 0.5 bar (7.25 lb/in²). Always wear protective clothing, protective gloves and protective goggles/safety mask.

Coolant temperature: at least 30 °C, whereby the component must also be at this temperature, 40 °C at the most, if the component must sometimes be held in hands.

Test pressure: 0.5 bar

Check securing elements of fuel line for damage and wear; replace components as necessary.

Check threads of union nuts and single-ended unions for ease of movement; recondition or replace part as required.

C 082.05.11 Installation

Installing fuel line from pump to filter

Note: Remove all blanking plugs before installation.

CAUTION
<p><small>Compressed air is air which has been compressed under pressure. If compressed air is used for blowing out or blow-drying components, always wear protective goggles or safety mask. Compressed air must not be directed at the body. Pressure must not exceed 3.0 bar (40 lb/in²).</small></p>

Blow out fuel line with compressed air and make sure it is perfectly clean.

Install fuel line with connecting and securing elements in accordance with General View, see C 082.05.01, or install tension-free as shown in the photo or as per markings.

Note: After engine start, visually inspect fuel system for leaks.

C 082.05.12 After-Installation Operations

A distinction must be made as to whether:

- 1 ————— The engine is to be completely disassembled
- | 2 ————— The engine is to be removed but not disassembled
- | | 3 — The engine is to remain installed

1	2	3	Operations	See
x	–	–	Perform operations as per Assembly Plan	B 005
x	–	–	Install engine	B 007
–	–	x	Release engine start	Operating Instructions



C 083.05 Fuel Filter

C 083.05.01 General View

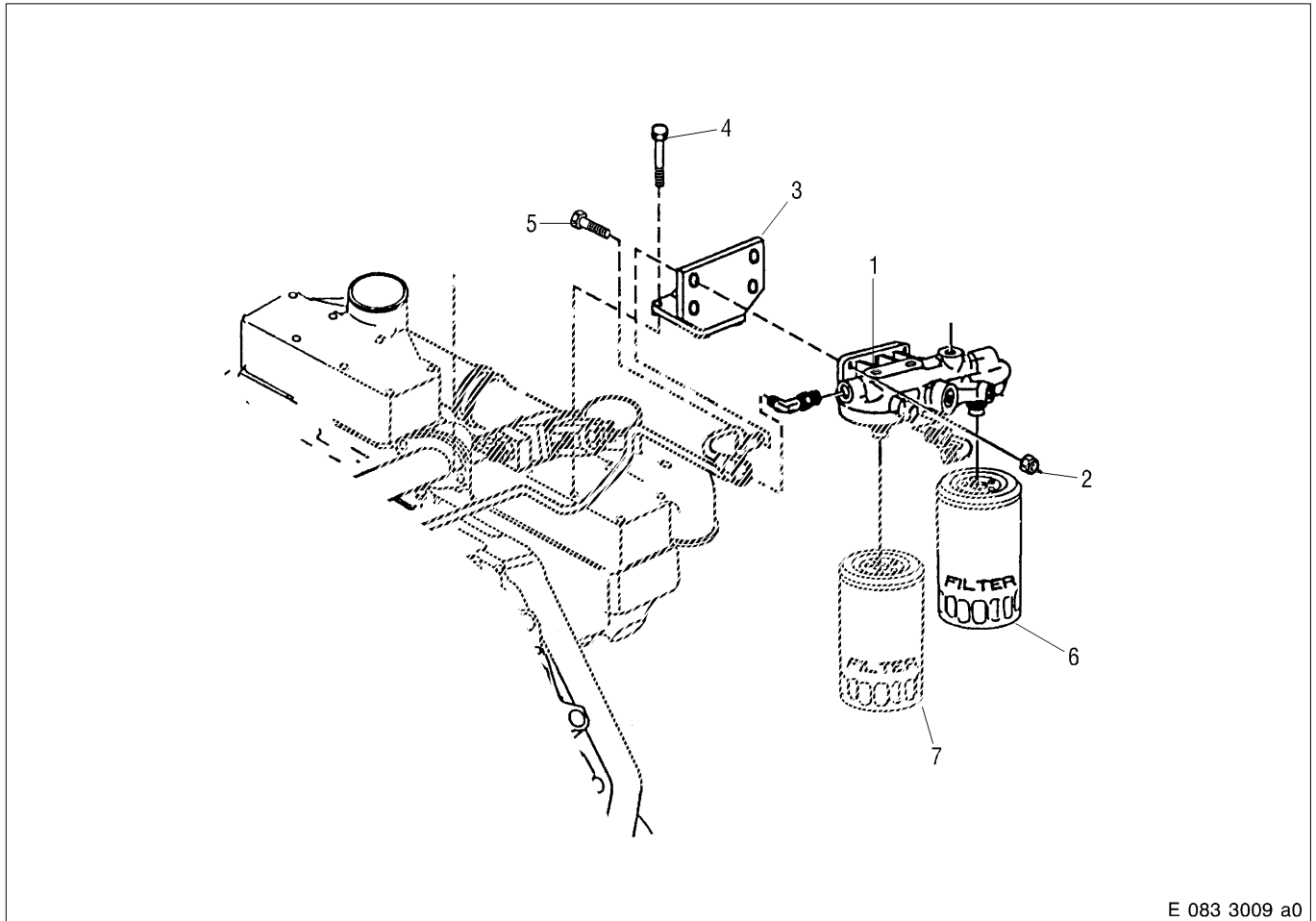

E 083 3009 a0

- 1 Fuel duplex filter
- 2 Nut
- 3 Carrier
- 4 Hex screw
- 5 Hex screw
- 6 Filter cartridge
- 7 Filter cartridge

C 083.05.02 Special Tool

Designation – Application

Number

Strap wrench for fuel filter

1

C 083.05.04 Before-Removal Operations

A distinction must be made as to whether:

- 1 — The engine is to be completely disassembled
- 2 — The engine is to be removed but not disassembled
- 3 — The engine is to remain installed

1	2	3	Operations	See
x	-	-	Remove engine	B 003
x	-	-	Perform operations as per Disassembly Plan	B 004
-	-	x	Disable engine start	Operating Instructions
-	x	x	Disconnect electric cables	-
-	x	x	Disconnect fuel lines	C 082.05/C 084.05

C 083.05.05 Removal

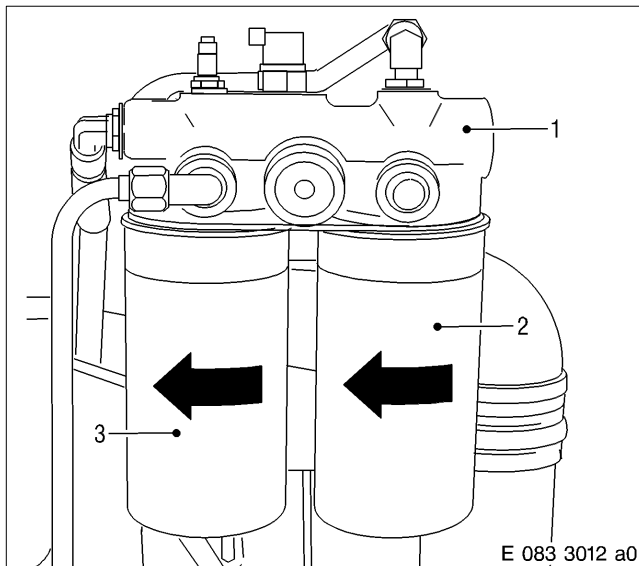

Removing fuel duplex filter

! WARNING

Fuels and fuel mists are flammable and poisonous. Risk of fire, explosions and poisoning!

When using fuel:

- do not use naked flame
- no electric sparks
- do not smoke
- do not spill fuel Do not inhale.

Always wear protective gloves and protective goggles/safety mask. Ventilate working area well.

Remove filter cartridges (2) and (3) with strap wrench (arrows) and dispose of in accordance with local regulations.

Note: Collect run-off fuel!

Remove fuel duplex filter (1) and carrier as shown in General View – see C 083.05.01.

Remove fuel temperature transmitter and fuel pressure transmitter from fuel duplex filter.

C 083.05.08 Inspection and Repair

Note: Make sure fuel-carrying components are perfectly clean.

Replace filter cartridges.

Check fuel temperature transmitter and fuel pressure transmitter in accordance with Special Publication.

Clean all components with "cleaner"; visually inspect for damage and check condition; replace component as necessary.

Brush off corrosion stains or water stains in fuel duplex filter.



CAUTION

Compressed air is air pressurised by overpressure. If compressed air is used for blowing out or blow-drying components, always wear protective goggles or safety mask. Compressed air must not be directed at the body. The pressure must not exceed 3.0 bar (40 lb/in²).

Blow fuel duplex filter through with compressed air and make sure they are perfectly clean.

If necessary, pressure-test fuel duplex filter with air in water bath for leaks.

Note: Mount filter cartridges for leak test.

Coolant temperature min. 30 °C – components must also be at this temperature; max. 40 °C, if component must be held in hands.



WARNING

Compressed air is air pressurised by overpressure. Risk of injury. Pressure must not exceed 0.5 bar (7.25 lb/in²). Always wear protective clothing, protective gloves and protective goggles/safety mask.

Test pressure: 0.5 bar

In event of leaks, replace blanking plug or replace fuel duplex filter.

Check sealing and mating faces for damage and defects; rub down with an oilstone or replace parts if necessary.

Check condition of threads; machine or replace components as necessary.

C 083.05.11 Installation

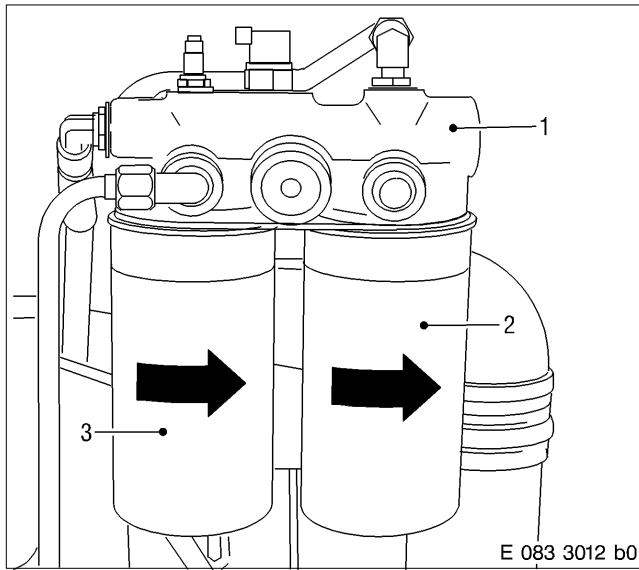

Installing fuel duplex filter

Note: Make sure all fuel-carrying components are perfectly clean.

Install fuel duplex filter (1) and carrier as shown in General View – see C 083.05.01.

Install fuel temperature transmitter and fuel pressure transmitter in accordance with Special Publication.

WARNING	
<p>Fuels and fuel mists are flammable and poisonous. Risk of fire, explosions and poisoning!</p> <p>When using fuel:</p> <ul style="list-style-type: none"> – do not use naked flame – no electric sparks – do not smoke – do not spill fuel Do not inhale. <p>Always wear protective gloves and protective goggles/safety mask. Ventilate working area well.</p>	

Fill filter cartridges (2) and (3) with clean fuel.

Coat sealing ring of filter cartridges with fuel.

Note: Do not use any tool to attach filter cartridges!

Install filter cartridges (arrows) and tighten manually.

Note: After engine start, visually inspect fuel system for leaks.

C 083.05.12 After-Installation Operations

A distinction must be made as to whether:

- 1** ————— The engine is to be completely disassembled
- 2** ————— The engine is to be removed but not disassembled
- 3** ————— The engine is to remain installed

1	2	3	Operations	See
x	–	–	Perform operations as per Assembly Plan	B 005
x	–	–	Install engine	B 007
–	x	x	Install fuel lines	C 082.05/C 084.05
–	x	x	Connect electric cables	–
–	–	x	Release engine start	Operating Instructions

C 084.05 Fuel Line from Filter to Injection Pump

C 084.05.01 General View

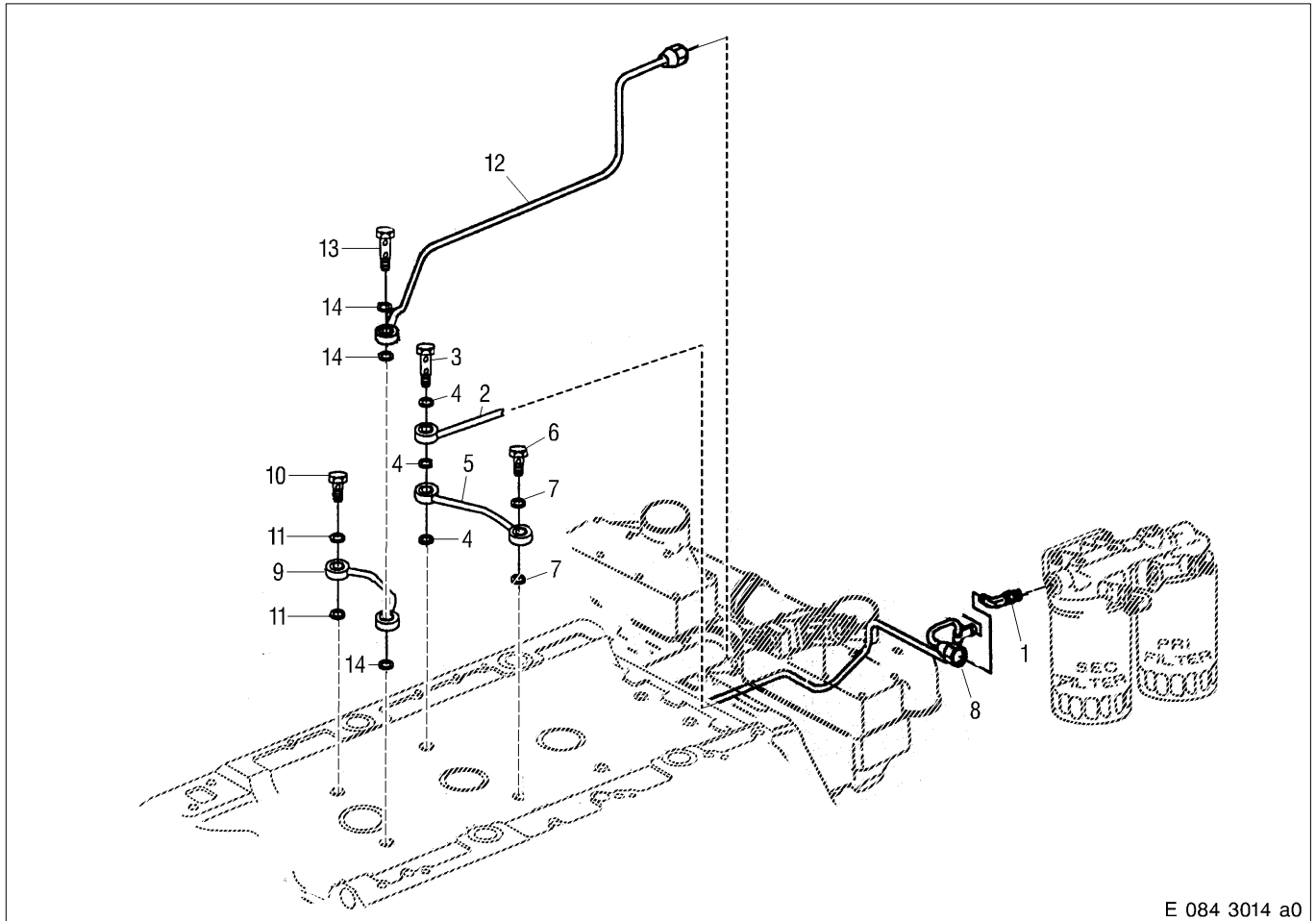

E 084 3014 a0

- | | | |
|----------------|----------------|-----------------|
| 1 Bracket | 6 Banjo screw | 11 Sealing ring |
| 2 Fuel line | 7 Sealing ring | 12 Fuel line |
| 3 Banjo screw | 8 Clamp | 13 Banjo screw |
| 4 Sealing ring | 9 Fuel line | 14 Sealing ring |
| 5 Fuel line | 10 Banjo screw | |

Fuel distributor housing

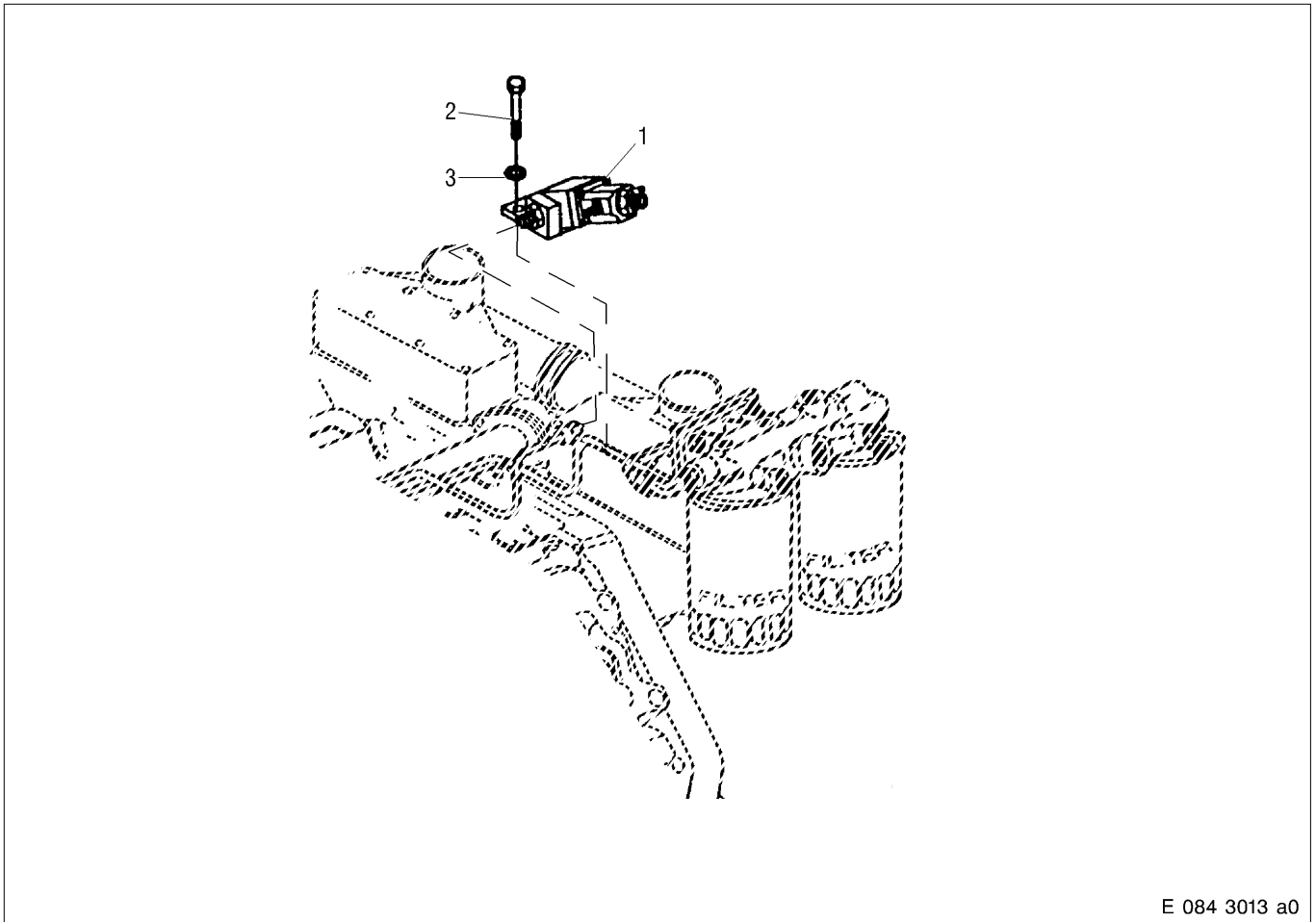

- 1 Distributor housing
- 2 Washer
- 3 Hex bolt

Fuel distributor housing

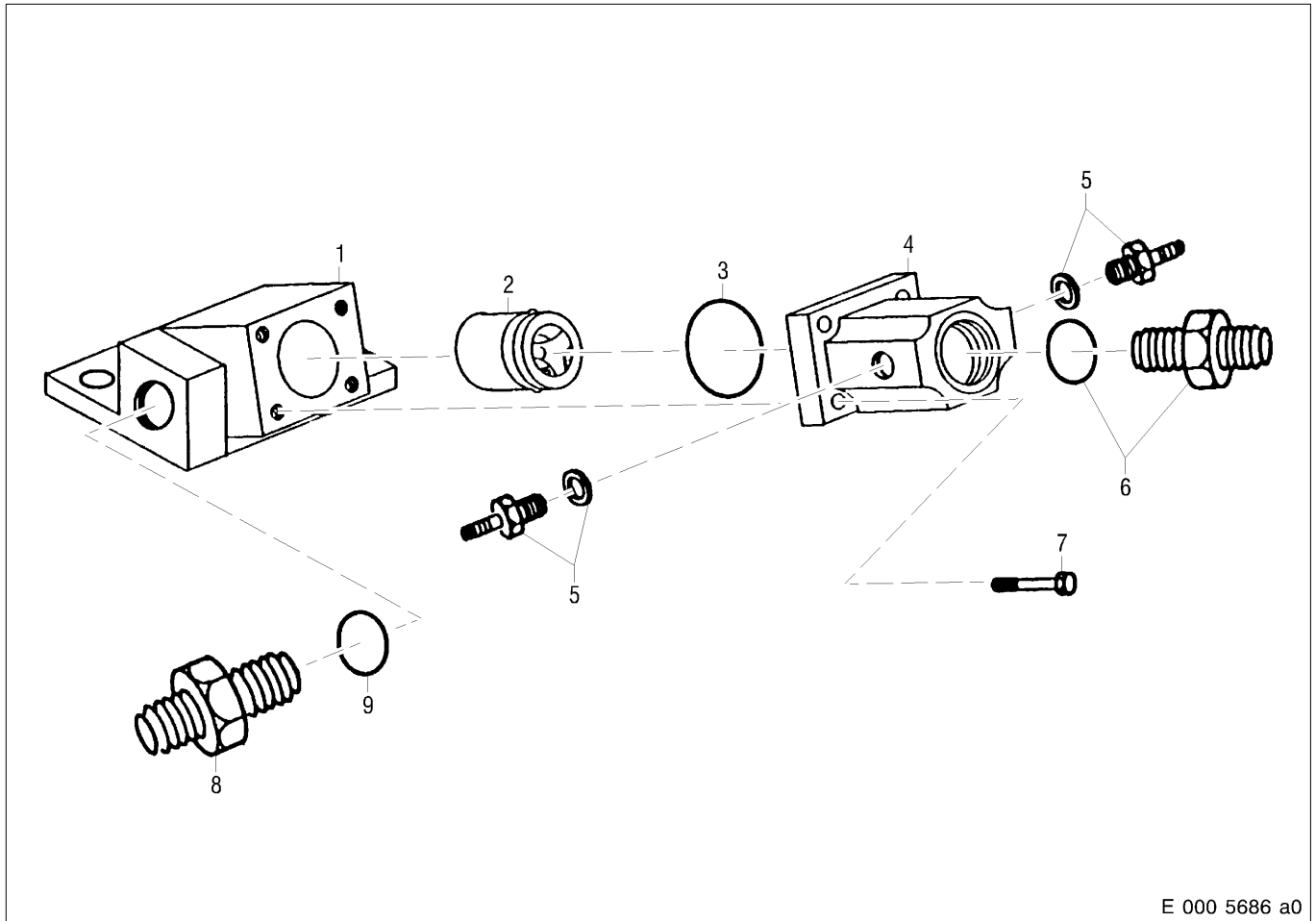

E 000 5686 a0

- | | | |
|---------------------------------|---------------------------------|---------------------------------|
| 1 Housing | 6 Union | 8 Union |
| 2 Pressure relief valve | Tightening torque: 54 Nm + 2 Nm | Tightening torque: 39 Nm + 2 Nm |
| 3 O-ring | Lubricant: Engine oil | Lubricant: Engine oil |
| 4 Cover | 7 Hex bolt | 9 O-ring |
| 5 Union | Tightening torque: 9 Nm + 1 Nm | |
| Tightening torque: 11 Nm + 1 Nm | Lubricant: Engine oil | |
| Lubricant: Engine oil | | |

C 084.05.04 Before-Removal Operations

A distinction must be made as to whether:

- 1 ————— The engine is to be completely disassembled
- 2 ————— The engine is to be removed but not disassembled
- 3 ————— The engine is to remain installed

1	2	3	Operations	See
x	-	-	Remove engine	B 003
x	-	-	Perform operations as per Disassembly Plan	B 004
-	-	x	Disable engine start	Operating Instructions

C 084.05.05 Removal

Removing fuel lines, distributor housing with pressure relief valve

Note: Before removing fuel lines, it is advisable to take photographs of the lines on the engine or to mark the fuel lines with metal tabs to facilitate reinstallation.



WARNING

Fuels and fuel vapours are inflammable and poisonous. Danger of fire, explosion and poisoning! When handling fuel: – do not use naked flame, – no electric sparks, – do not smoke, – do not spill fuel. Do not inhale. Always wear protective gloves and protective goggles/safety mask. Ventilate working area well.

Release fuel line threaded connection and catch fuel emerging in a suitable container.

Remove fuel lines, distributor housing with pressure relief valve and securing elements in accordance with General View, see C 084.05.01.

After removal, cover all connections with suitable plugs.

C 084.05.06 Disassembly

Disassembling distributor housing

Disassemble distributor housing as shown in C 084.05.01.

Unscrew unions, remove O-rings and sealing rings.

C 084.05.08 Inspection and Repair

Note: Make sure fuel-carrying components are perfectly clean.

Clean all components with cleaner and visually inspect for condition and damage; replace component as necessary.



CAUTION

Compressed air is air which has been compressed under pressure. If compressed air is used for blowing out or blow-drying components, always wear protective goggles or safety mask. Compressed air must not be directed at the body. Pressure must not exceed 3.0 bar (40 lb/in²).

Blow out fuel lines with compressed air and make sure they are perfectly clean.

Check fuel lines with air under water for leakages; replace if leaks are found.



WARNING

Compressed air is air which has been compressed under pressure. Risk of injury. Pressure must not exceed 0.5 bar (7.25 lb/in²). Always wear protective clothing, protective gloves and protective goggles/safety mask.

Coolant temperature: at least 30 °C, whereby the component must also be at this temperature, 40 °C at the most, if the component must sometimes be held in hands.

Test pressure: 0.5 bar

Check all threads for ease of movement; recondition or replace part as required.

Check sealing and bolt-on faces for wear and damage; smooth with oilstone or emery cloth.

Replace sealing rings and O-rings at every disassembly.

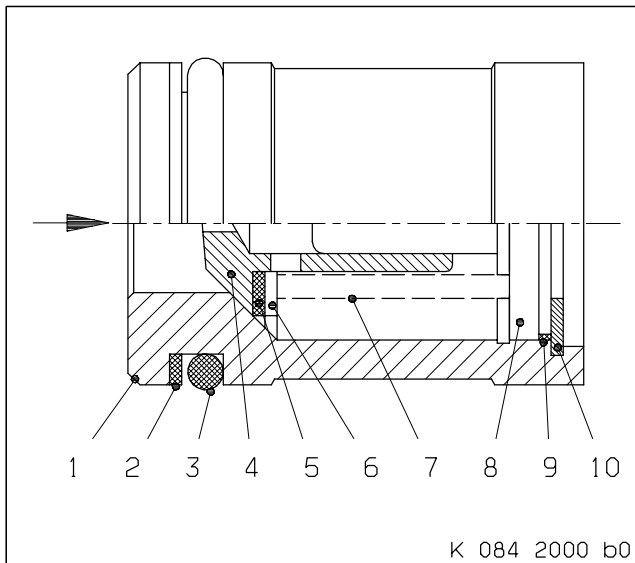

Checking pressure relief valve

- 1 Housing
- 2 Support ring
- 3 O-ring
- 4 Valve
- 5 Sealing washer
- 6 Washer
- 7 Compression spring
- 8 Valve guide
- 9 Ring
- 10 Snap ring

Make visible inspection of pressure relief valve for wear and damage; replace if necessary.

Check opening pressure of pressure relief valve , observe flow direction (arrow).

WARNING

**Test fluid is pressurised.
Risk of injury.
Liquids emerging under high-pressure can lead to serious injury!
Always wear protective clothing, protective gloves and protective goggles/safety mask.**

Opening pressure: 8.5 bar \pm 1 bar

If opening pressure cannot be reached, replace pressure relief valve.

C 084.05.10 Assembly

Assembling distributor housing

Note: Make sure parts are perfectly clean.

Assemble distributor housing with new O-rings and sealing rings in accordance with General View, see C 084.05.01; observe specified torques.

Ensure that pressure relief valve is positioned correctly in accordance with General View.

Coat O-rings with petroleum jelly before installation.

C 084.05.11 Installation

Installing distributor housing with pressure relief valve and fuel lines

Note: Remove all blanking plugs before installation.

CAUTION

Compressed air is air which has been compressed under pressure. If compressed air is used for blowing out or blow-drying components, always wear protective goggles or safety mask. Compressed air must not be directed at the body. Pressure must not exceed 3.0 bar (40 lb/in²).

Blow out fuel lines with compressed air and make sure they are perfectly clean.

Check that sealing surfaces and fuel bores in the crankcase are perfectly clean; clean if necessary

Install fuel lines and distributor housing tension-free with new sealing rings, with connecting and securing elements in accordance with General View, see C 084.05.01.

Note: After engine start, visually inspect fuel system for leaks.



C 084.05.12 After-Installation Operations

A distinction must be made as to whether:

- 1 ————— The engine is to be completely disassembled
- | 2 ————— The engine is to be removed but not disassembled
- | | 3 — The engine is to remain installed
- | | |

1	2	3	Operations	See
x	-	-	Perform operations as per Assembly Plan	B 005
x	-	-	Install engine	B 007
-	-	x	Release engine start	Operating Instructions

C 086.05 Leak-off Fuel Line

C 086.05.01 General View

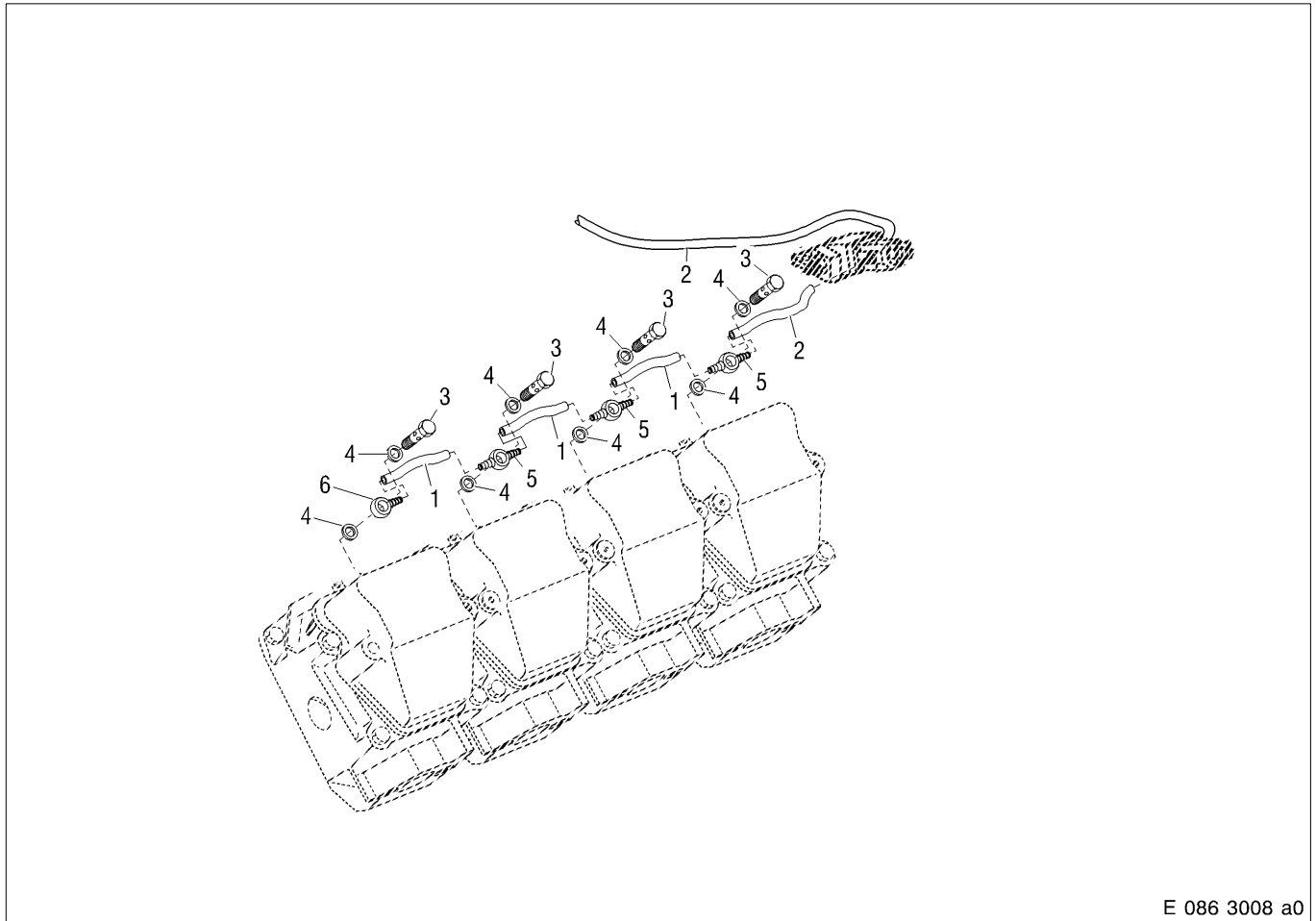

- | | |
|---------------|----------------|
| 1 Fuel line | 4 Sealing ring |
| 2 Fuel line | 5 Connector |
| 3 Banjo screw | 6 Connector |

C 086.05.04 Before-Removal Operations

A distinction must be made as to whether:

- | | | |
|---|-------|--|
| 1 | ————— | The engine is to be completely disassembled |
| 2 | ——— | The engine is to be removed but not disassembled |
| 3 | — | The engine is to remain installed |

1	2	3	Operations	See
x	—	—	Remove engine	B 003
x	—	—	Perform operations as per Disassembly Plan	B 004
—	—	x	Disable engine start	Operating Instructions

C 086.05.05 Removal

Disconnecting leak-off fuel lines



WARNING

Fuels and fuel mists are flammable and poisonous. Risk of fire, explosions and poisoning! When using fuel: – do not use naked flame – no electric sparks – do not smoke – do not spill fuel Do not inhale. Always wear protective gloves and protective goggles/safety mask. Ventilate working area well.

Release banjo screws on fuel lines and catch fuel emerging.

Remove fuel line in accordance with General View – see C 086.05.01.

Remove sealing rings.

After removing lines, seal all open connections by installing suitable plugs.

C 086.05.08 Inspection and Repair

Note: Make sure fuel-carrying components are perfectly clean.

Clean all components with "cleaner"; visually inspect for damage and check condition; replace component as necessary.

Check condition of sealing surfaces of connecting elements and of banjo screws; check thread for ease of movement; replace components as necessary.

Replace sealing rings as part of every assembly.

Replace hoses of fuel line as part of every W6 overhaul.

C 086.05.11 Installation

Connecting leak-off fuel lines

Note: Prior to installation, remove all blanking plugs.



CAUTION

Compressed air is air which has been compressed under pressure. If compressed air is used for blowing out or blow-drying components, always wear protective goggles or safety mask. Compressed air must not be directed at the body. The pressure must not exceed 3.0 bar (40 lb/in²).

Blow lines through with compressed air and make sure they are perfectly clean.

Ensure fuel bores and sealing surfaces on cylinder heads are perfectly clean; clean if necessary.

Install lines with banjo screws and new sealing rings as shown in General View – see C 086.05.01, making sure lines are free of tension.

Note: After engine start, visually inspect fuel system for leaks.

C 086.05.12 After-Installation Operations

A distinction must be made as to whether:

- 1 ————— The engine is to be completely disassembled
- 2 ————— The engine is to be removed but not disassembled
- 3 ————— The engine is to remain installed

1	2	3	Operations	see
x	-	-	Perform operations as per Assembly Plan	B 005
x	x	-	Install engine	B 007
-	-	x	Release engine start	Operating Instructions



Contents

C 100	Exhaust Turbocharger
C 101.01	Exhaust turbocharger
C 101.01.01	General view
C 101.01.04	Before-removal operations
C 101.01.05	Removal
C 101.01.06	Disassembly
C 101.01.08	Inspection and repair
C 101.01.10	Assembly
C 101.01.11	Installation
C 101.01.12	After-installation operations

C 100 Exhaust Turbocharger

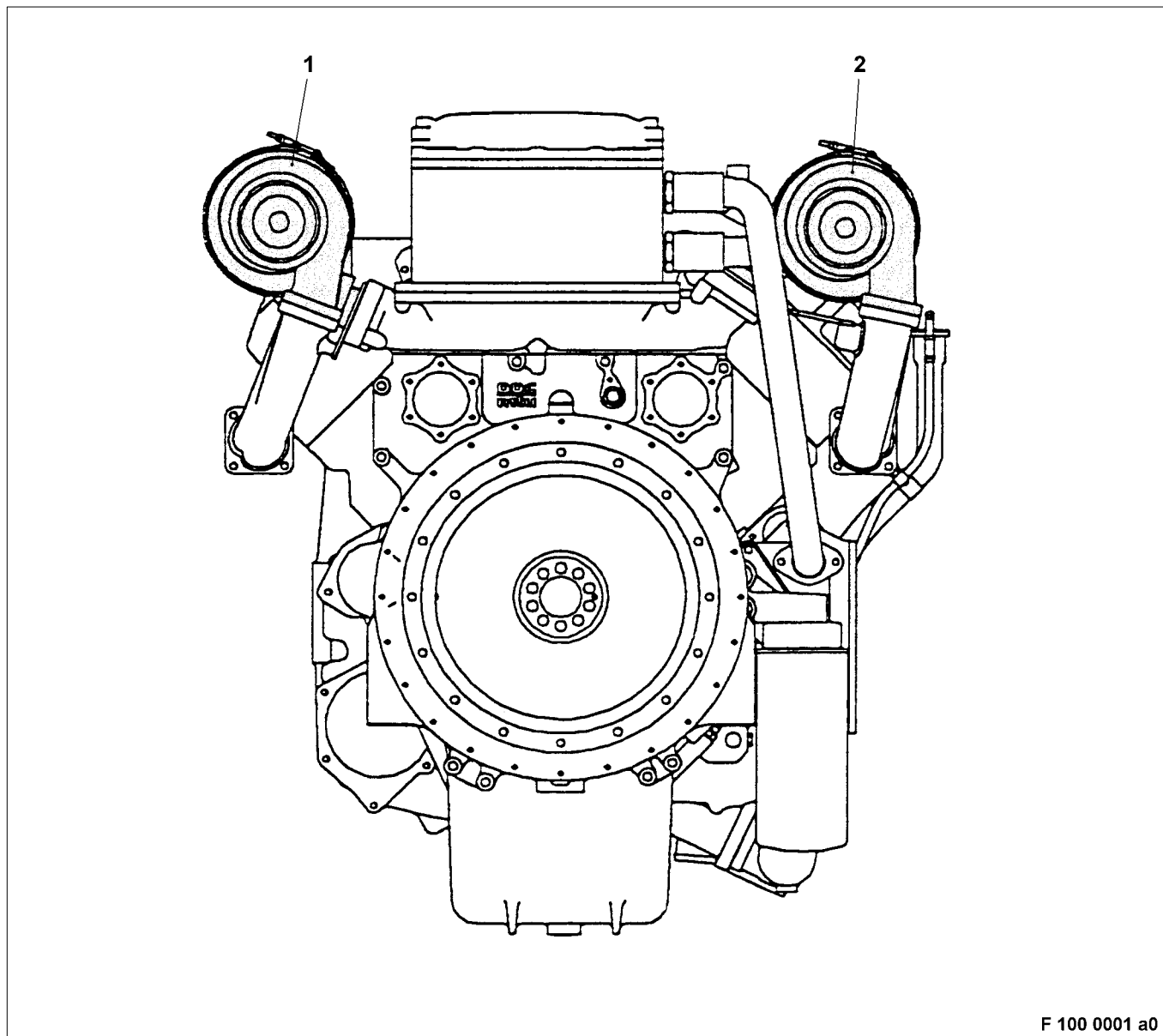

F 100 0001 a0

- 1 Exhaust turbocharger, left
- 2 Exhaust turbocharger, right

The following is a list of auxiliary equipment and materials needed for the assembly operations:

CAUTION

When using these chemical substances, it is essential to observe the Manufacturer's Instructions for use, safety instructions and waste disposal specifications.

Materials and consumables	Designation	Order No.		Remarks
		MTU	DDC	
Emery cloth				
Magnifying glass				
Vaseline	Petroleum jelly, white	40317		
Assembly paste	Ultra Therm MTU	50547		
Corrosion preventive	Caramba Express	40008		
Engine oil				
Cleaning agent	Solvclean KW	40022		
Kerosene or diesel fuel				
Dry compressed air				
Denaturated ethanol		40250		



C 101.01 Exhaust Turbocharger

C 101.01.01 General View

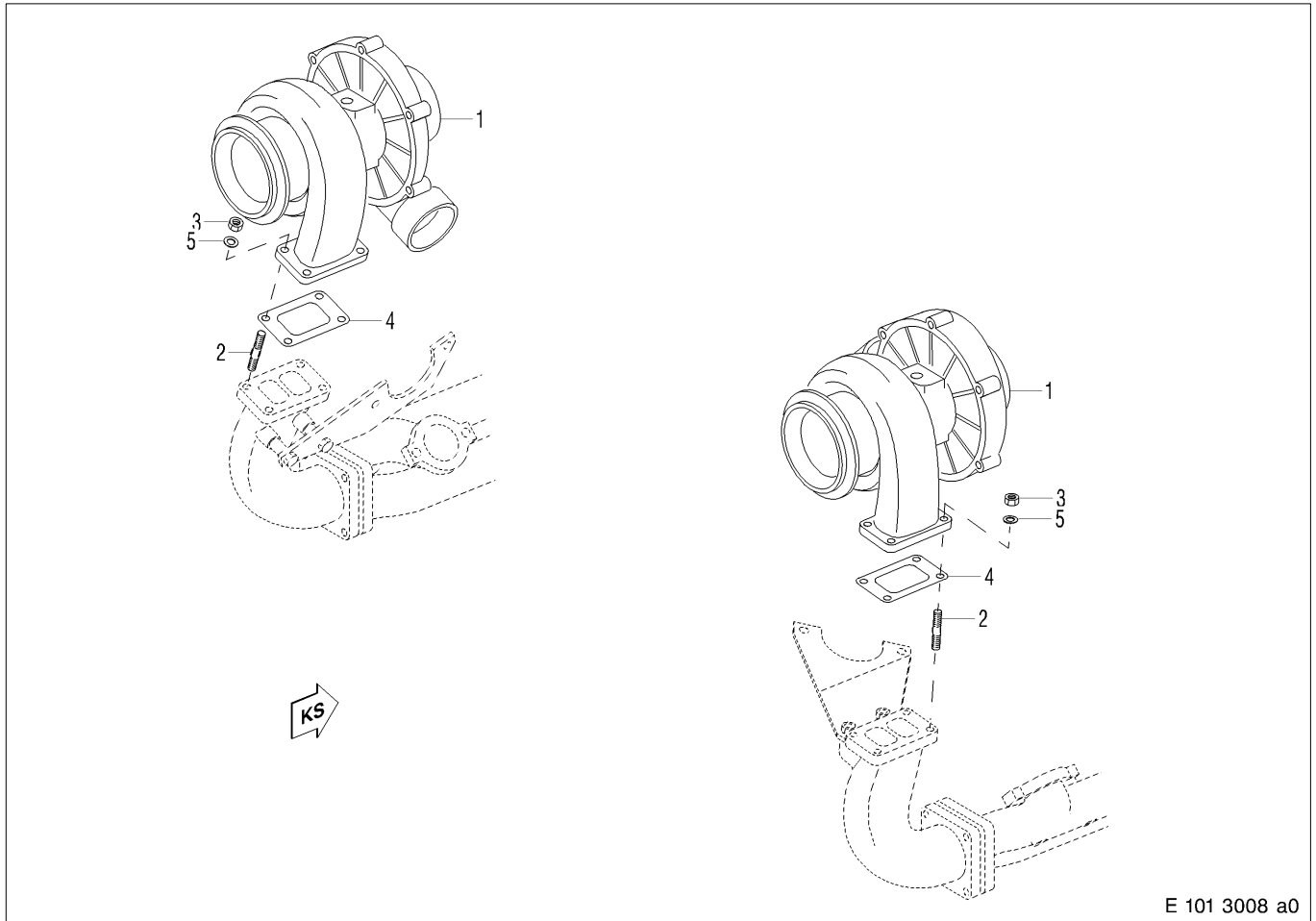

- 1 Exhaust turbocharger
- 2 Stud
- 3 Nut

- 4 Gasket
- 5 Washer

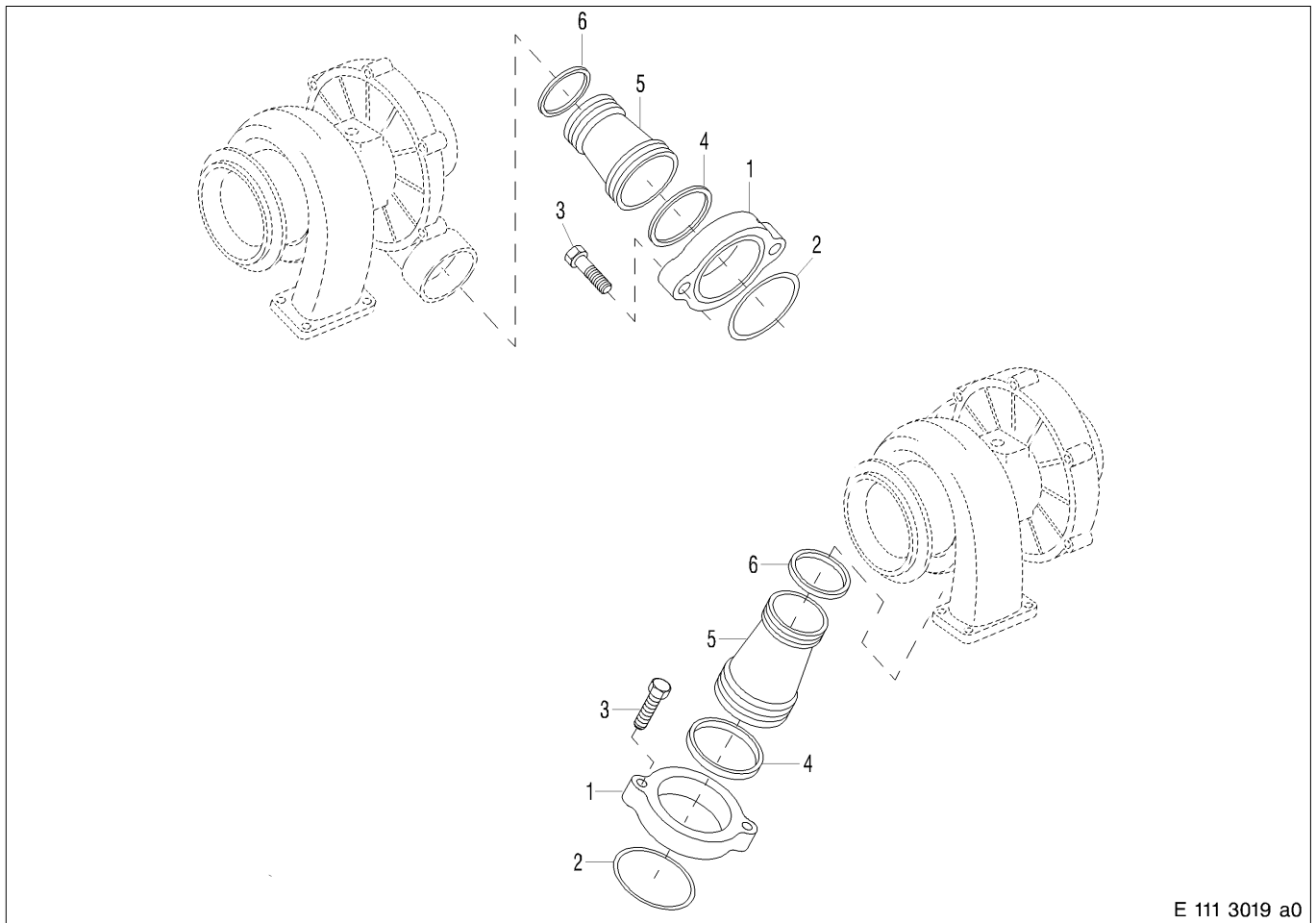

E 111 3019 a0

- 1 Sealing flange
- 2 Sealing ring
- 3 Hex screw
- 4 Sealing ring
- 5 Spacer tube
- 6 Sealing ring

C 101.01.04 Before-Removal Operations

A distinction must be made as to whether:

- 1 ————— The engine is to be completely disassembled
- 2 ————— The engine is to be removed but not disassembled
- 3 ————— The engine is to remain installed

1	2	3	Operations	See
x	-	-	Remove engine	B 003
x	-	-	Perform operations as per Disassembly Plan	B 004
-	-	x	Disable engine start	Operating Instructions
-	x	x	Remove air system before exhaust turbocharger	-
-	x	x	Remove exhaust system after exhaust turbocharger	-
-	x	x	Remove oil supply lines for turbochargers	C 185.10
-	x	x	Remove oil return lines for turbochargers	C 185.25

C 101.01.05 Removal

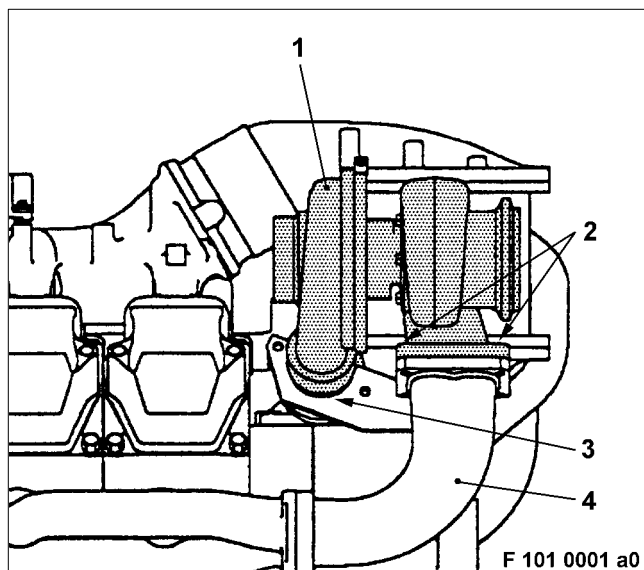

Removing exhaust turbocharger

Remove hex bolts for sealing flange from intercooler as shown in General View – see C 101.01.01.

Remove bracket – see C 142.05.01.

Remove nuts (2) and washers for exhaust turbocharger (1) from exhaust elbow (4).

Remove exhaust turbocharger from exhaust elbow.

Remove gasket.

Remove spacer tube (3) and sealing flange.

Remove sealing rings.

C 101.01.06 Disassembly

Disassembling exhaust turbocharger

See Special Publication

C 101.01.08 Inspection and Repair

Overhaul exhaust turbocharger as shown in special publication .

Clean all components and visually inspect for damage and defects; replace as necessary.

Check all sealing and seating faces for damage and surface irregularities; rub down with an oilstone or emery cloth as necessary.

Check thread of studs for ease of movement; replace studs as necessary

Replace nuts, washers, sealing rings and gaskets.

C 101.01.10 Assembly

Assembling exhaust turbocharger

See Special Publication

C 101.01.11 Installation

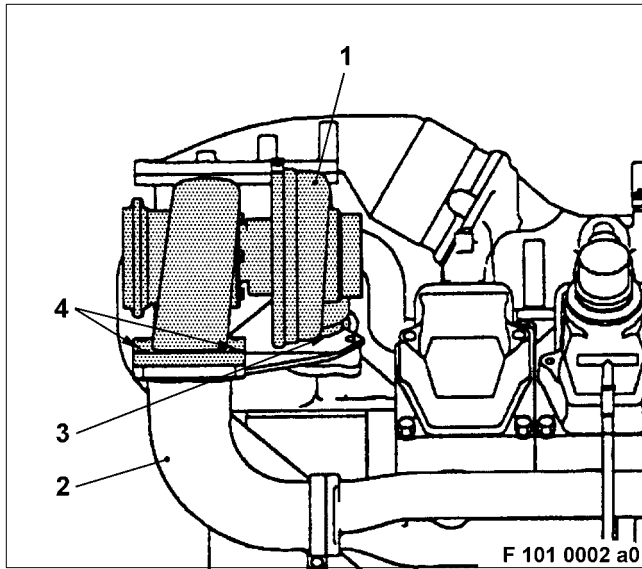

Installing turbocharger

Coat sealing rings with assembly paste and fit on spacer tube and in sealing flange – see C 101.01.01. Insert spacer tube (3) into compressor housing (1) of exhaust turbocharger.

Fit sealing flange on spacer tube.

Check mating face on exhaust turbocharger, on exhaust elbow (4) and on intercooler; clean as necessary.

Fit new gasket via studs on exhaust elbow.

By means of studs, lower exhaust turbocharger onto exhaust elbow.

Mount retainer – see C 142.05.01 and tighten screws for flange.

Install nuts (2) and washers on studs and tighten diagonally and evenly.

C 101.01.12 After-Installation Operations

A distinction must be made as to whether:

- 1 ——— The engine is to be completely disassembled
- 2 ——— The engine is to be removed but not disassembled
- 3 ——— The engine is to remain installed

1	2	3	Operations	See
x	–	–	Perform operations as per Assembly Plan	B 005
x	–	–	Install engine	B 007
–	x	x	Install oil supply lines for turbochargers	C 185.10
–	x	x	Install oil return lines for turbochargers	C 185.25
–	x	x	Install exhaust system after exhaust turbocharger	–
–	x	x	Install air system before exhaust turbocharger	–
–	–	x	Release engine start	Operating Instructions

Contents

C 110	Charge Air Cooling
C 111.05	Intercooler
C 111.05.01	General view
C 111.05.04	Before-removal operations
C 111.05.05	Removal
C 111.05.08	Inspection and repair
C 111.05.11	Installation
C 111.05.12	After-installation operations

C 110 Charge Air Cooling

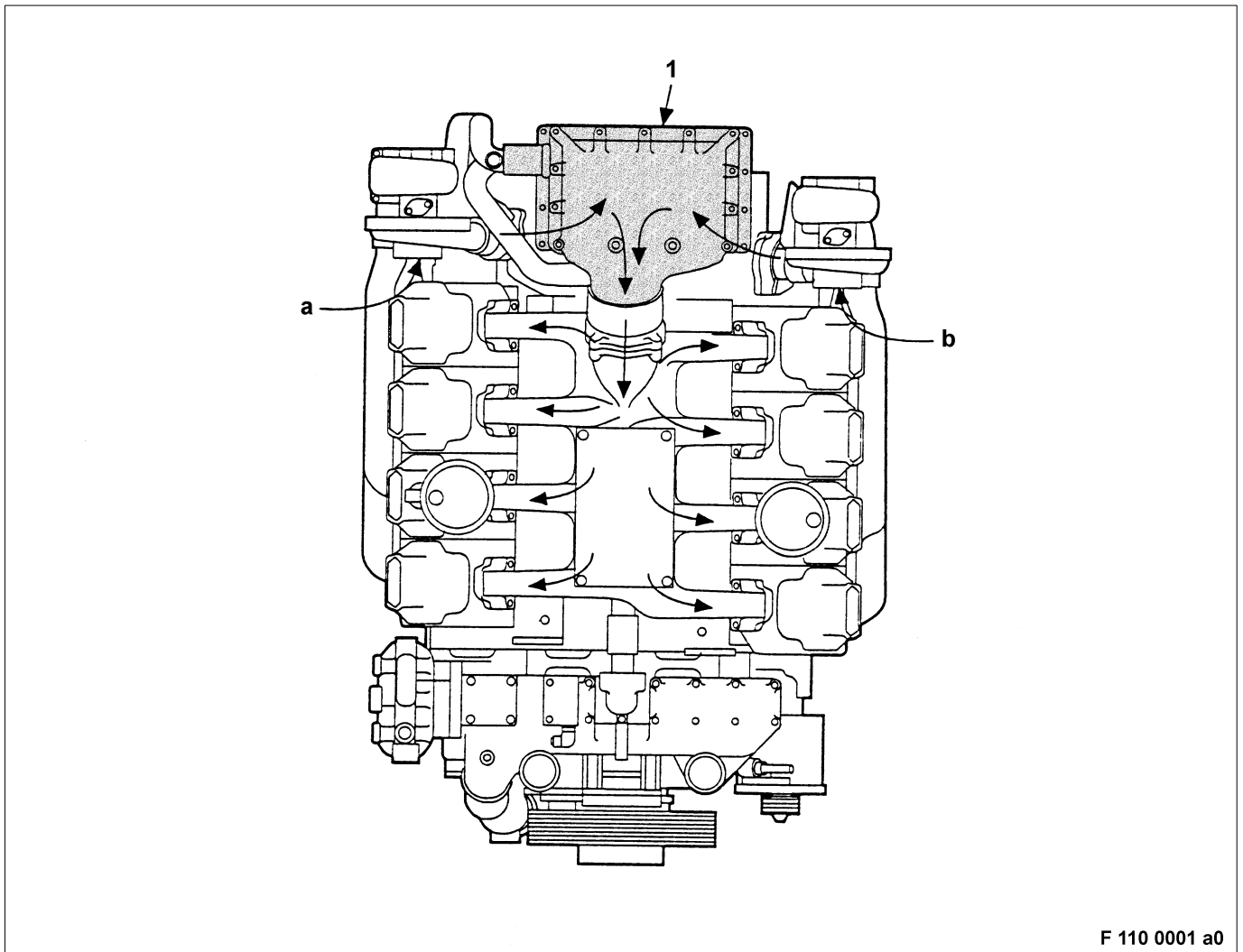

F 110 0001 a0

- 1 Intercooler
- a Air inlet, right
- b Air inlet, left

The following is a list of auxiliary equipment and materials needed for the assembly operations:

!	CAUTION
<p>When using these chemical substances, it is essential to observe the Manufacturer's Instructions for use, safety instructions and waste disposal specifications.</p>	

Materials and consumables	Designation	Order No.		Remarks
		MTU	DDC	
Emery cloth				
Magnifying glass				
Spray gun				
Inspection lamp				
Vaseline	Petroleum jelly, white	40317		
Cleansing agent	Solvclean KW	40022		
Cleansing agent (carbon-deposit remover)	Meister Proper	40377		
Decalcifying agent	Porodox or Porozink			
Preservation agent	Branol 32/10			
Engine oil				
Kerosene or diesel fuel				
Assembly paste	Ultra Therm MTU	50547		
Sealing paste	Elastosil N 189	50545		
Multipurpose grease	Shell Retinax A	40333		
Denaturated ethanol		40250		
Corrosion preventive	Caramba Express	40008		
Engineer's blue	blue	40641		
Dry compressed air				
Surface crack-testing equipment with red penetrant dye				



C 111.05 Intercooler

C 111.05.01 General View

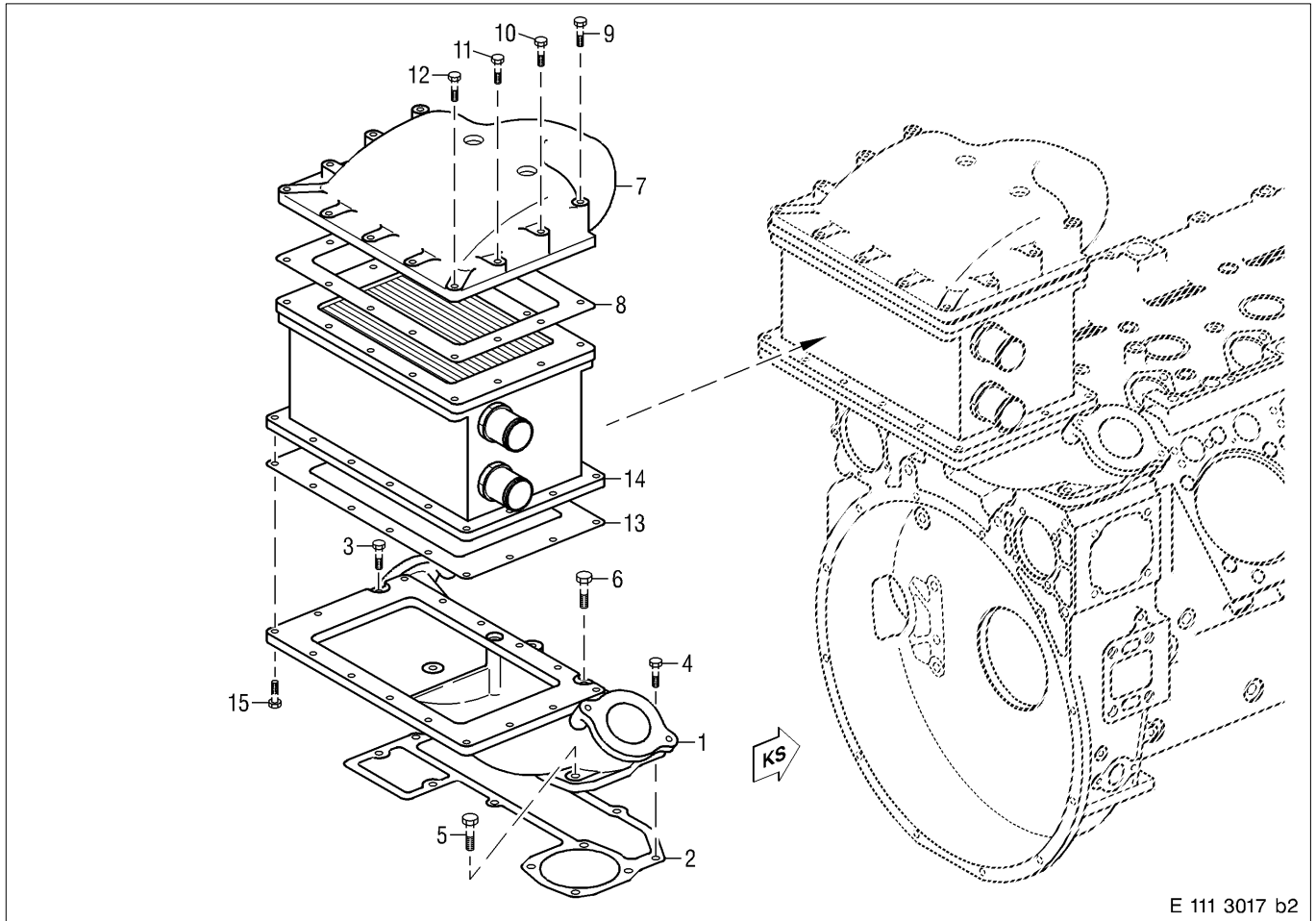

E 111 3017 b2

- | | | |
|----------------------|----------------------|----------------|
| 1 Connecting housing | 6 Hex screw | 11 Hex screw |
| 2 Gasket | 7 Connecting housing | 12 Hex screw |
| 3 Hex screw | 8 Gasket | 13 Gasket |
| 4 Hex screw | 9 Hex screw | 14 Intercooler |
| 5 Hex screw | 10 Hex screw | 15 Hex screw |

C 111.05.04 Before-Removal Operations

A distinction must be made as to whether:

- 1 ————— The engine is to be completely disassembled
- 2 ————— The engine is to be removed but not disassembled
- 3 ————— The engine is to remain installed

1	2	3	Operations	See
x	–	–	Remove engine	B 003
x	–	–	Perform operations as per Disassembly Plan	B 004
–	–	x	Disable engine start	Operating Instructions
–	–	x	Drain engine coolant	Operating Instructions
–	x	x	Remove coolant lines	C 202.15

C 111.05.05 Removal

Removing intercooler

Remove intercooler and connecting housing as shown in General View – see C 111.05.01.

Remove gaskets.

After removal, seal all connections with suitable plugs.

Protect intercooler (especially cooling fins) against mechanical damage (impacts etc.).

Seal cooler networks with cardboard for example.

C 111.05.08 Inspection and Repair

Clean all components and visually inspect for damage and defects; replace as necessary.

Check connecting housing for cracks using surface crack–testing method with red penetrant dye.

If cracks are detected, replace part.

Check all sealing, mating and seating faces for damage and surface irregularities; rub down with an oilstone or emery cloth as necessary.

Check thread in connecting housing for ease of movement; recondition as necessary.

Replace sealing rings and gaskets.

Clean air and coolant sides of intercoolers.

Cleaning air side:

CAUTION

Compressed air is air which has been compressed under pressure. If compressed air is used for blowing out or blow-drying components, always wear protective goggles or safety mask. Compressed air must not be directed at the body. The pressure must not exceed 3.0 bar (40 lb/in²).

a) Blow through cooler with a compressed air jet or spray a powerful water jet in the opposite direction to the cooling air flow. The jet must be directed parallel to the cooling fins in order to prevent the fins being deformed.

Important! It is imperative to avoid damaging the cooler, especially the cooling fins!



CAUTION

Take special care when using high-pressure jet. Risk of injury!
Never direct water jet at humans, animals, equipment or electric components.
Always wear protective clothing, protective gloves and protective goggles/safety mask.

b) If greasy or oily deposits have formed, cooler must be cleaned with a steam cleaner.

Use nozzle for multi-point water jet. Operating pressure of H.P. cleaning unit should be at approx. 80 bar. Use clear water at a temperature of approx. 70 °C (to prevent steam).

Direct cleaning jet as in a) above.

After cleaning, blow through cooling air ducts with compressed air in vertical direction.

Cleaning coolant side:

It is essential to examine extent of contamination of water side prior to cleaning.

The water side must be cleaned if there is visible encrustation on the water side (inlet area) due to crustations, contamination and oil deposits.

Fill cooler with descaling agent.



CAUTION

When using these chemical substances, it is essential to observe the Manufacturer's Instructions for use, safety instructions and waste disposal specifications.

An agent which is not aggressive to metal surfaces (e.g. Porodox from Henkel or Porozink from Parobe-Chemie, Basel) must be used to remove deposited material.

Follow the manufacturer's instructions to the letter when preparing the descaling solution.

Dwell time depends on the condition and temperature of the solution and the nature and stubbornness of the deposits.

After cleaning, flush the cooler with water until pH values of clean water and rinsing water are approximately the same (difference 1 pH).

Normal coolant can be used for flushing purposes.

If the required level of cleanness is not achieved, repeat the above procedure.

If the cooler is not put into operation immediately afterwards, after this cleaning the water side must be dried and then preserved.

Dry in a drying oven between 110 °C and 120 °C. Oven drying time: approx. 3 hours.

Spray preservation agent (Branol 32/10 from Brangs and Heinrich) into cooler. The preservation agent condenses and falls to form a protective layer over the inner surfaces.

Make sure dosages are correct! 2 ml Branorol 32/10 per litre of coolant.

After preservation, seal all openings with suitable end covers air-tight.

Checking intercooler for leaks

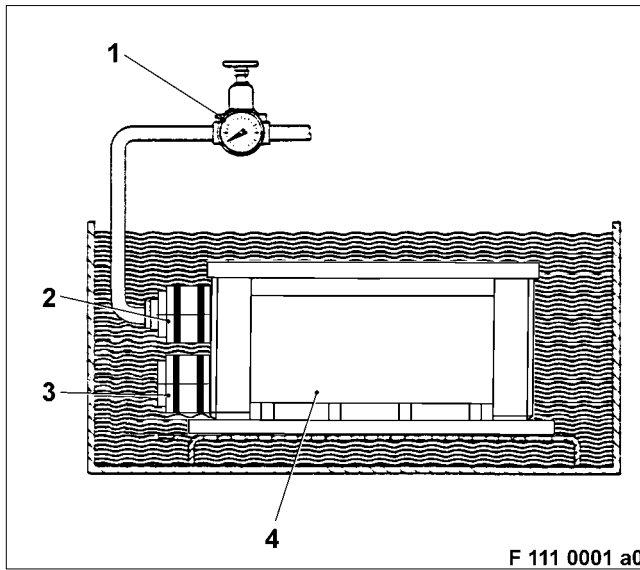

Seal coolant chamber connections on intercooler (4) with suitable sleeves, blank plugs (3), plug with connection (2) and clamps.

At plug with connection, seal compressed air line.

! WARNING

Compressed air is air which has been compressed under pressure. Test fluid is hot 80 °C (180°F). Risk of injury! Pressure must not exceed 0.5 bar (7.25 lb/in²). Always wear protective clothing, protective gloves and protective goggles/safety mask.

Soak intercooler in test basin filled with water heated to 80 °C.

Open compressed air supply and set pressure reducer (1) to 0.5 bar.

Pressure test intercooler for leaks with air in water bath; no bubbles should emerge.

Replace intercooler if leaks are found.

! CAUTION

Compressed air is air which has been compressed under pressure. If compressed air is used for blowing out or blow-drying components, always wear protective goggles or safety mask. Compressed air must not be directed at the body. The pressure must not exceed 3.0 bar (40 lb/in²).

After checking, blow through cooling air ducts with compressed air in vertical direction.

C 111.05.11 Installation

Installing intercooler

Note: Prior to installation, remove all blanking plugs and seals and ensure air-carrying lines are perfectly clean.

Mount intercooler and connecting housing with new gaskets as shown in General View – see C 111.05.01.

C 111.05.12 After-Installation Operations

A distinction must be made as to whether:

- 1 — The engine is to be completely disassembled
- 2 — The engine is to be removed but not disassembled
- 3 — The engine is to remain installed

1	2	3	Operations	See
x	–	–	Perform operations as per Assembly Plan	B 005
x	–	–	Install engine	B 007
–	x	x	Connect coolant lines	C 202.15
–	–	x	Fill engine coolant system	Operating Instructions
–	–	x	Release engine start	Operating Instructions

Contents

C 120	Air Intake/Air Supply
C 124.05	Air supply to cylinders
C 124.05.01	General view
C 124.05.04	Before-removal operations
C 124.05.05	Removal
C 124.05.08	Inspection and repair
C 124.05.11	Installation
C 124.05.12	After-installation operations

C 120 Air Intake/Air Supply

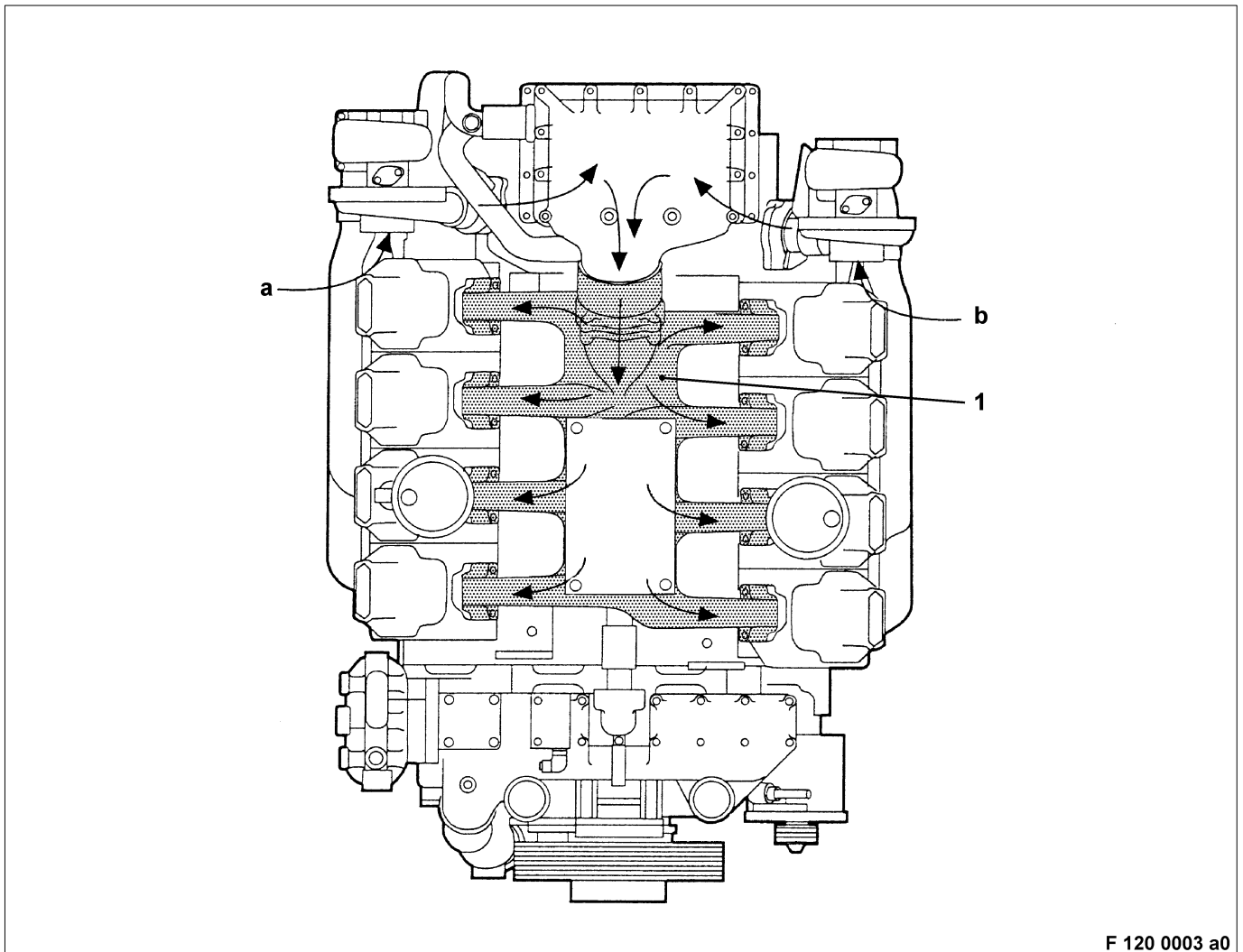

F 120 0003 a0

- 1 Charge air manifold
- a Air inlet, right
- b Air inlet, left

The following is a list of auxiliary equipment and materials needed for the assembly operations:

CAUTION

When using these chemical substances, it is essential to observe the Manufacturer's Instructions for use, safety instructions and waste disposal specifications.

Materials and consumables	Designation	Order No.		Remarks
		MTU	DDC	
Emery cloth				
Spray gun				
Inspection lamp				
Vaseline	Petroleum jelly, white	40317		
Surface sealant	Loctite No. 573	40031		Final strength ≈ 48 hrs
Corrosion preventive	Pfinder AP 11 F	40355		
Engine oil				
Assembly paste	Ultra Therm MTU	50547		
Cleaning agent	Solvclean KW	40022		
Cleaning agent (carbon-deposit remover)	Meister Proper	40377		
Engineer's blue	blue	40641		
Kerosene or diesel fuel				
Denaturated ethanol		40250		
Corrosion preventive	Caramba Express	40008		
Dry compressed air				
Surface crack-testing equipment with red penetrant dye				



C 124.05 Air Supply to Cylinders

C 124.05.01 General View

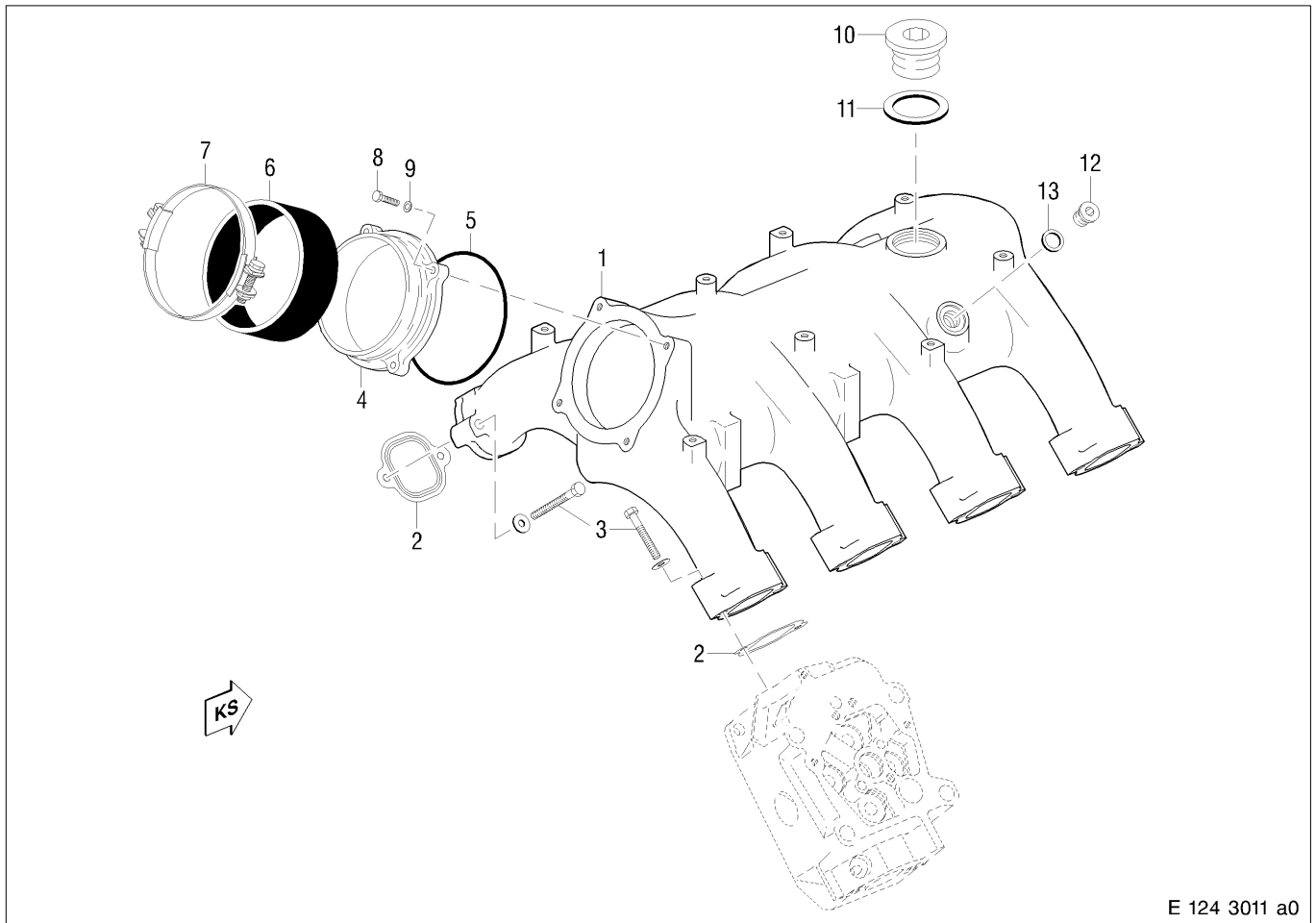

- | | | |
|--------------------------|-----------------|-----------------|
| 1 Charge air manifold | 4 Flange | 9 Washer |
| 2 Gasket | 5 Sealing ring | 10 Plug |
| 3 Hex screw | 6 Rubber sleeve | 11 Sealing ring |
| Tightening torque: 25 Nm | 7 Clamp | 12 Plug |
| Lubricant: Engine oil | 8 Hex screw | 13 Sealing ring |

C 124.05.04 Before-Removal Operations

- 1 ——— The engine is to be completely disassembled
 2 ——— The engine is to be removed but not disassembled
 3 ——— The engine is to remain installed

1	2	3	Operations	See
x	—	—	Remove engine	B 003
x	—	—	Perform operations as per Disassembly Plan	B 004
—	—	x	Disable engine start	Operating Instructions
—	x	x	Disconnect electric wiring	—
—	x	x	Remove ECU housing and bracket	Special Publication

C 124.05.05 Removal

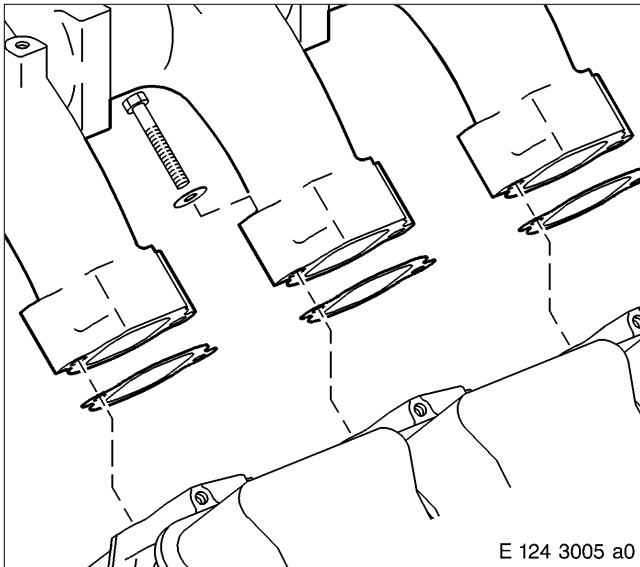

Removing charge air manifold

Release clamps as shown in General View – see C 124.05.01.

Remove hex bolts and washers for charge air manifold.

Remove charge air manifold and gaskets.

Remove charge air temperature transmitter and charge air pressure transmitter.

After removal, seal all apertures with suitable plugs or covers.

C 124.05.08 Inspection and Repair

Check charge air temperature transmitter and charge air pressure transmitter in accordance with special publication.

Clean all air-carrying components with cleaning agent.

Pressure-test charge air manifold for leaks with air in water bath.



WARNING

Compressed air is air which has been compressed under pressure. Risk of injury. Pressure must not exceed 0.5 bar (7.25 lb/in²). Always wear protective clothing, protective gloves and protective goggles/safety mask.

Air pressure = 0.5 bar

Check charge air manifold for cracks using surface crack-testing method with red penetrant dye as necessary.

Replace charge air manifold in event of leaks or cracks.

Check sealing and mating faces for surface irregularities and damage; rub down with an oilstone if necessary.

Check condition of threads; re chase threads if necessary or replace threaded inserts if necessary.

Check clamps for condition and screws for ease of movement; replace if necessary.

Check hex bolts for damage and wear; replace as necessary.

Replace sealing ring, O-ring and gaskets.

Replace rubber sleeve as part of every W6 overhaul.

C 124.05.11 Installation

Installing charge air manifold

Note: Prior to installation, remove all blanking plugs and seals and ensure air-carrying lines are perfectly clean.

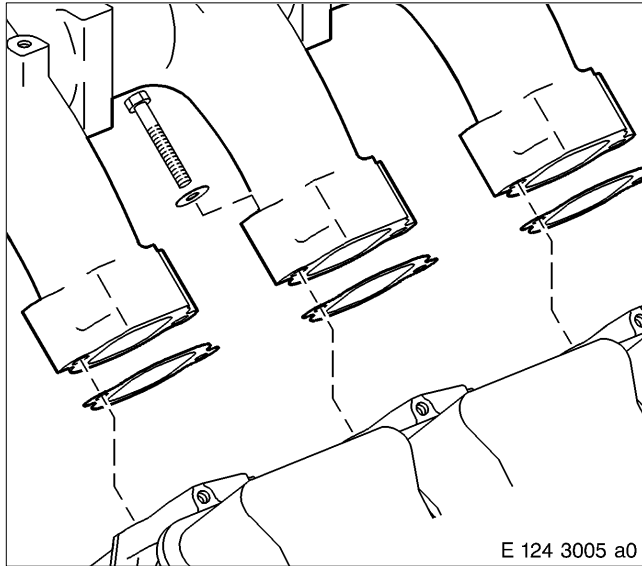

Install charge air temperature transmitter and charge air pressure transmitter – see Special Publication.
Check sealing surfaces on cylinder heads and on charge air manifold; clean as necessary.
Fit gaskets on cylinder heads.
Mount charge air manifold as shown in General View, see C 124.05.01, and tighten securing screws to specified tightening torque.
Before installation, coat O-ring with assembly paste.

C 124.05.12 After-Installation Operations

A distinction must be made as to whether:

- 1 ————— The engine is to be completely disassembled
- 2 ————— The engine is to be removed but not disassembled
- 3 ————— The engine is to remain installed

1	2	3	Operations	See
x	–	–	Perform operations as per Assembly Plan	B 005
x	–	–	Install engine	B 007
–	x	x	Install ECU housing and bracket	Special Publication
–	x	x	Connect electric cables	–
–	–	x	Release engine start	Operating Instructions



Contents

C 140	Exhaust System
C 142.05	Exhaust manifold
C 142.05.01	General view
C 142.05.04	Before-removal operations
C 142.05.05	Removal
C 142.05.08	Inspection and repair
C 142.05.11	Installation
C 142.05.12	After-installation operations

C 140 Exhaust System

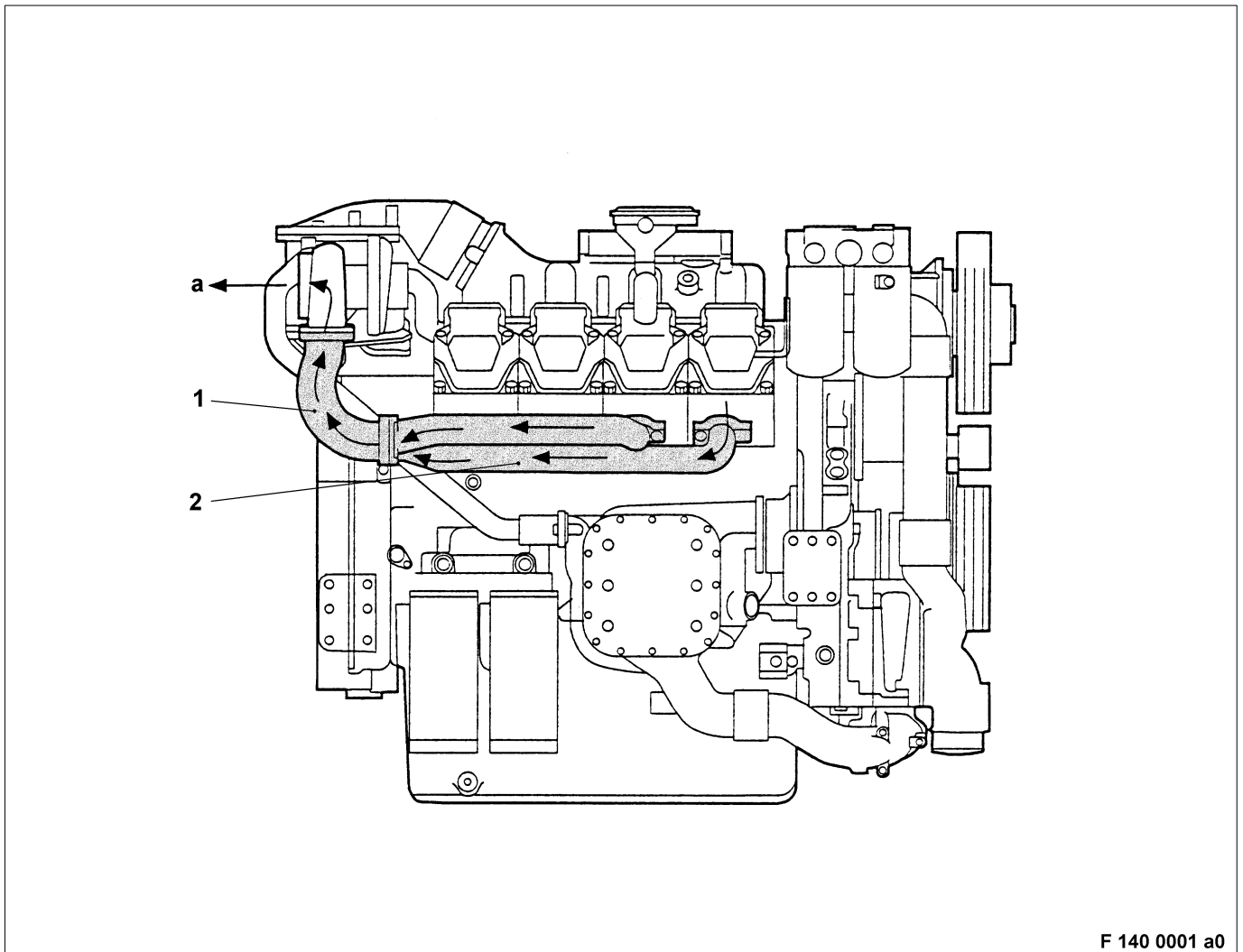

F 140 0001 a0

- 1 Exhaust elbow
- 2 Exhaust manifold
- a Exhaust outlet

The following is a list of auxiliary equipment and materials needed for the assembly operations:

CAUTION

When using these chemical substances, it is essential to observe the Manufacturer's Instructions for use, safety instructions and waste disposal specifications.

Materials and consumables	Designation	Order No.		Remarks
		MTU	DDC	
Emery cloth				
Magnifying glass				
Corrosion preventive	Pfinder AP 11 F	40355		
Vaseline	Petroleum jelly, white	40317		
Assembly paste	Ultra-Therm	50547		
Cleaning agent (carbon-deposit remover)	Meister Proper	40377		
Engine oil				
Cleaning agent	Solvclean KW	40022		
Engineer's blue	blue	40641		
Synthetic shot-blasting pellets	Dry Strip Type 216/20	20098		
Kerosene or diesel fuel				
Corrosion preventive	Caramba Express	40008		
Dry compressed air				
Surface crack-testing equipment with red penetrant dye				



C 142.05 Exhaust Manifold

C 142.05.01 General View

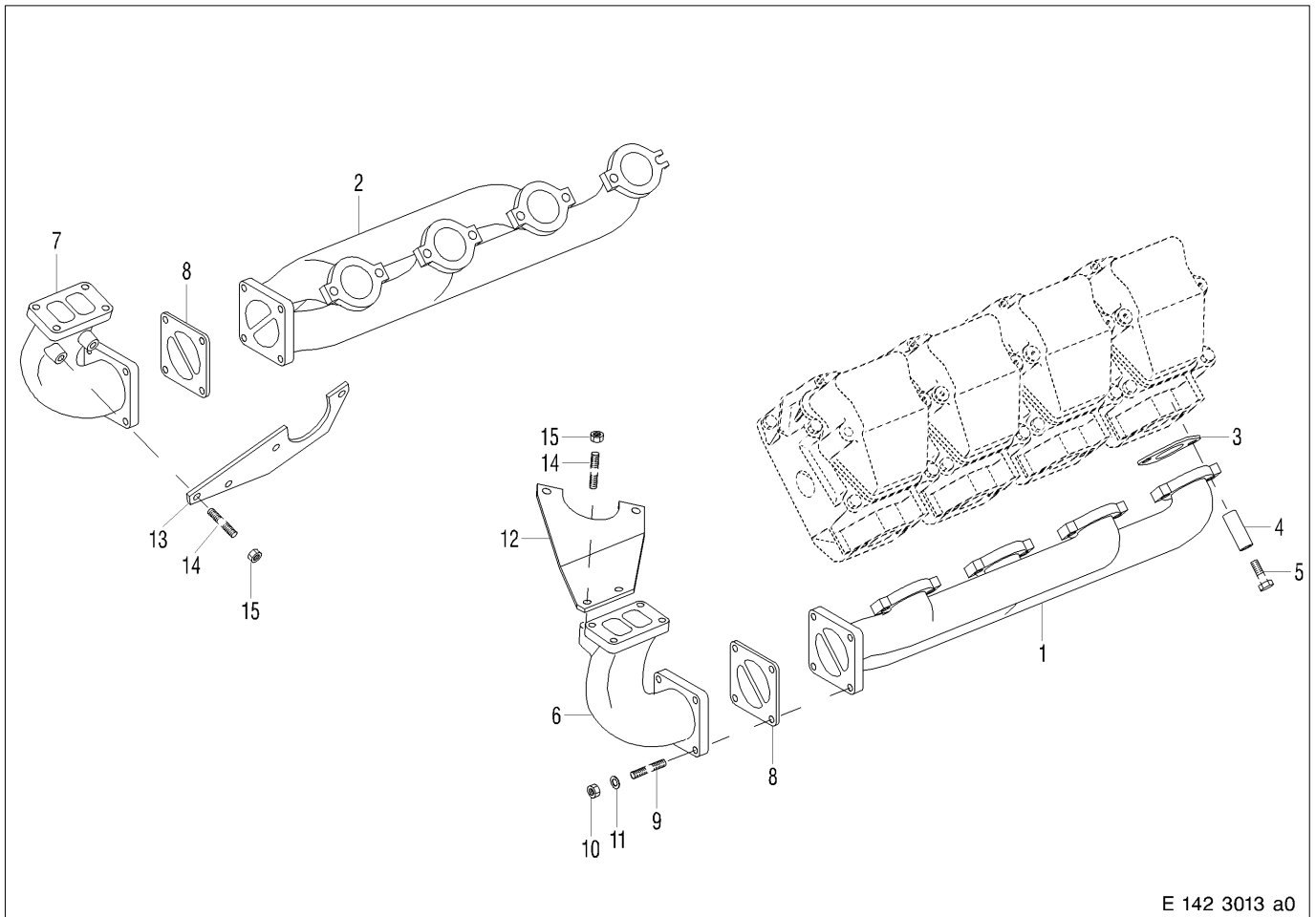

- | | | |
|----------------|-----------------|------------|
| 1 Exhaust line | 6 Exhaust elbow | 11 Washer |
| 2 Exhaust line | 7 Exhaust elbow | 12 Bracket |
| 3 Gasket | 8 Gasket | 13 Bracket |
| 4 Spacer | 9 Stud | 14 Stud |
| 5 Hex screw | 10 Nut | 15 Nut |
- Tightening torque: 60 Nm
Lubricant: Assembly paste

C 142.05.04 Before-Removal Operations

A distinction must be made as to whether:

- 1 ————— The engine is to be completely disassembled
- 2 ————— The engine is to be removed but not disassembled
- 3 ————— The engine is to remain installed

1	2	3	Operations	See
x	–	–	Remove engine	B 003
x	–	–	Perform operations as per Disassembly Plan	B 004
–	–	x	Disable engine start	Operating Instructions
–	x	x	Remove exhaust turbocharger	C 101.01
–	x	x	Remove oil filler pipe (as necessary)	C 182.10
–	x	x	Remove oil dipstick and guide tube (as necessary)	C 182.10

C 142.05.05 Removal

Removing exhaust manifold

Remove bracket for exhaust elbow, exhaust elbow and exhaust manifolds as shown in General View – see C 142.05.01.

Remove gaskets.

C 142.05.08 Inspection and Repair

Clean all components and visually inspect for damage and defects; replace as necessary.



CAUTION

When using these chemical substances, it is essential to observe the Manufacturer’s Instructions for use, safety instructions and waste disposal specifications.

Place exhaust elbow and exhaust pipes in a container containing decarbonizer.

Dwell time depends on thickness of deposits.

After cleaning with carbon-deposit remover, rinse components in water until no further residues are washed off.

If deposits are stubborn, use synthetic shot-blasting pellets (nominal size 16 to 20) to help cleaning.

Using the surface crack-testing method with red penetrant dye, check exhaust elbow and exhaust lines for cracks; replace component if cracks are found.

Check exhaust lines for warping; replace line in event of warping.

Check sealing and mating faces; rub down with emery cloth or an oilstone or replace components as necessary.

Check thread in exhaust manifold and in exhaust elbow for ease of movement; rechase as necessary.

Replace gaskets, hex bolts, studs and nuts.

C 142.05.11 Installation

Installing exhaust manifold

Prior to installing exhaust manifold, use a steel straightedge to check all cylinder heads on one engine for alignment; realign cylinder heads as necessary.

Check sealing surfaces on exhaust manifold, exhaust elbow and cylinder heads; clean as necessary.

Mount exhaust lines, exhaust elbow and bracket for exhaust elbow with spacers, with new gaskets, hex bolts, nuts and stud free of tension as shown in General View – see C 142.05.01.

Tighten hex bolts to specified tightening torque – see C 142.05.01.

C 142.05.12 After-Installation Operations

A distinction must be made as to whether:

- 1 ————— The engine is to be completely disassembled
- 2 ————— The engine is to be removed but not disassembled
- 3 ————— The engine is to remain installed

1	2	3	Operations	See
x	-	-	Perform operations as per Assembly Plan	B 005
x	-	-	Install engine	B 007
-	x	x	Install turbocharger	C 101.01
-	x	x	Install oil filler pipe	C 182.10
-	x	x	Install guide tube and oil dipstick	C 182.10
-	-	x	Release engine start	Operating Instructions



Contents

C 170	Starting System
C 172.05	Starter
C 172.05.01	General view
C 172.05.04	Before-removal operations
C 172.05.05	Removal
C 172.05.06	Disassembly
C 172.05.08	Inspection and repair
C 172.05.10	Assembly
C 172.05.11	Installation
C 172.05.12	After-installation operations

C 170 Starting System

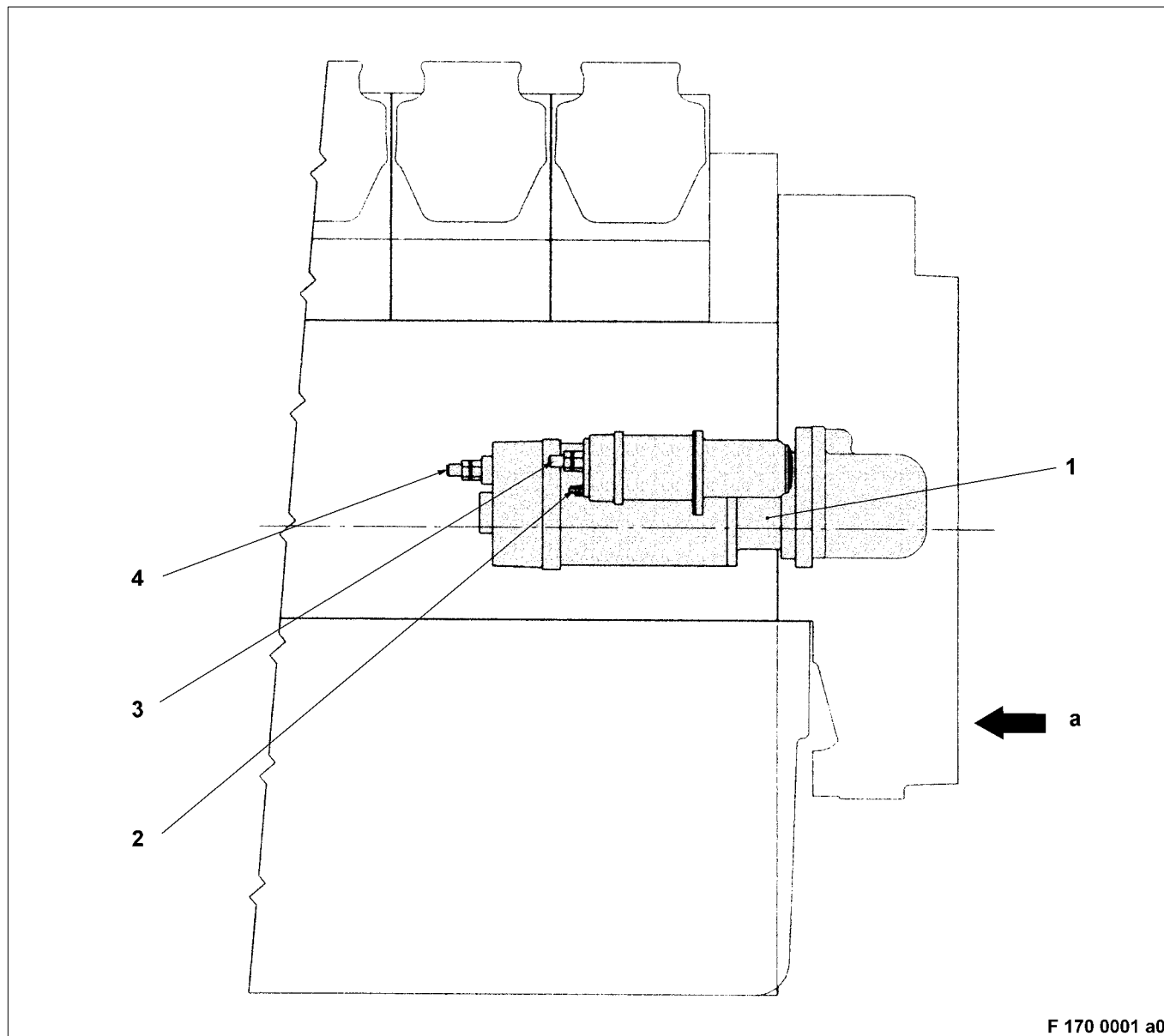

F 170 0001 a0

- 1 Starter
- 2 Switching terminal
- 3 Battery terminal
- 4 Battery terminal
- a Driving end

The following is a list of auxiliary equipment and materials needed for the assembly operations:



CAUTION

When using these chemical substances, it is essential to observe the Manufacturer's Instructions for use, safety instructions and waste disposal specifications.

Materials and consumables	Designation	Order No.		Remarks
		MTU	DDC	
Emery cloth				
Magnifying glass				
Vaseline	Vaseline grease, white	40317		
Longlife grease	Longterm 2 Plus	40337		
Engine oil				
Cleaning agent	Solvclean KW	40022		
Corrosion preventive	Caramba Express	40008		
Dry compressed air				
Kerosene or diesel fuel				



C 172.05 Starter

C 172.05.01 General View

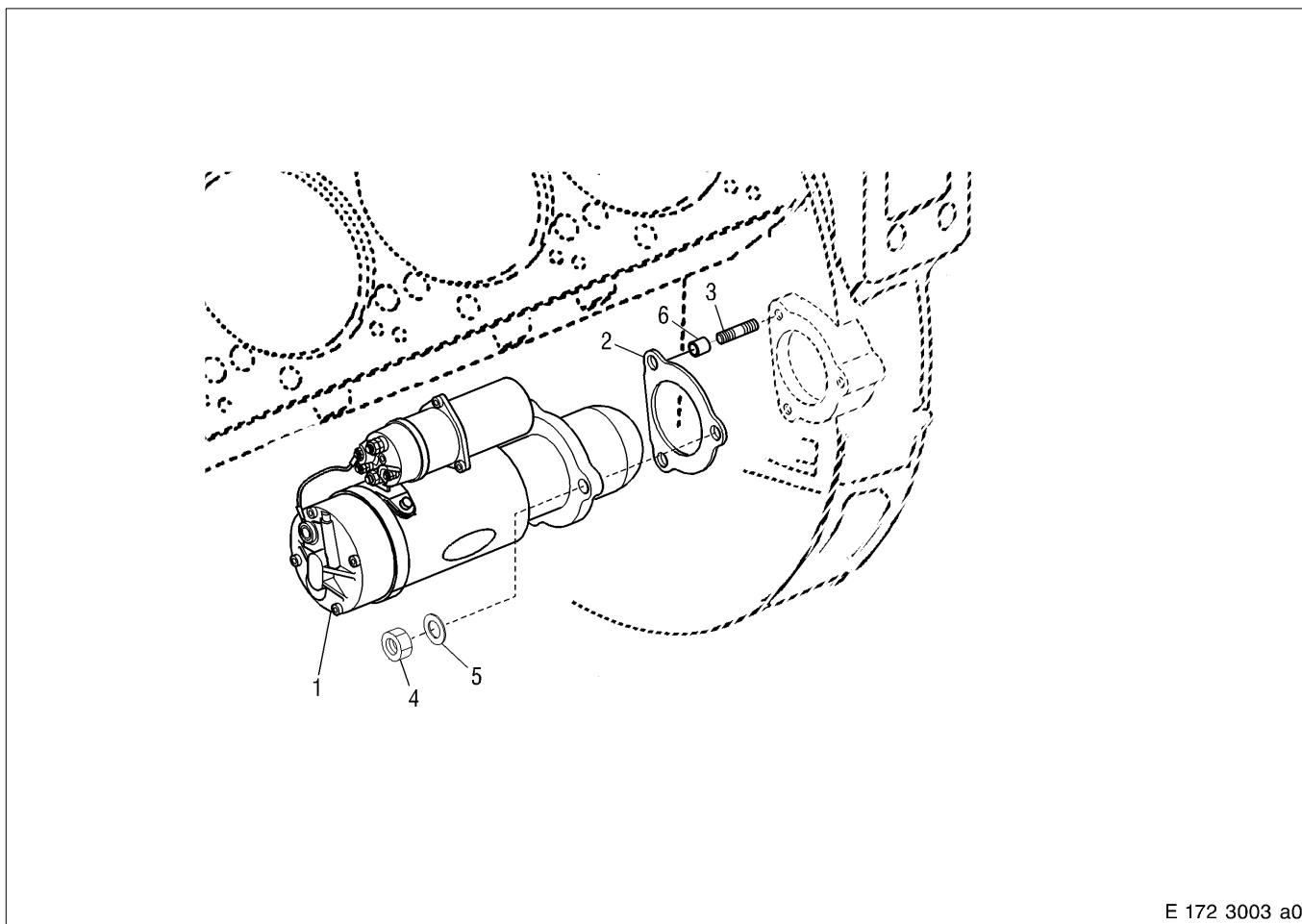

E 172 3003 a0

- | | |
|--------------------------|----------|
| 1 Starter | 5 Washer |
| 2 Gasket | 6 Bush |
| 3 Stud | |
| 4 Nut | |
| Tightening torque: 80 Nm | |
| Lubricant: Engine oil | |

C 172.05.04 Before-Removal Operations

A distinction must be made as to whether:

- 1 ————— The engine is to be completely disassembled
 | 2 ————— The engine is to be removed but not disassembled
 | | 3 — The engine is to remain installed

1	2	3	Operations	See
x	—	—	Remove engine	B 003
x	—	—	Perform operations as per Disassembly Plan	B 004
—	—	x	Disable engine start	Operating Instructions



C 172.05.05 Removal

Removing starter

Note: Before removal, ensure that the negative battery pole is disconnected!

Mark cable at starter if necessary and remove.

Remove nuts and washers for starter as shown in General View – see C 172.05.01.

Pull starter from its seat and remove.

C 172.05.06 Disassembly

See Manufacturer’s Documentation.

C 172.05.08 Inspection and Repair

Inspect and repair individual parts of starter in accordance with Manufacturer’s documentation.

Clean starter externally and check for damage and check condition.

Note: During cleaning operations, ensure that no moisture can penetrate inner parts of solenoid switch. If moisture penetrates solenoid switch it results in corrosion and circuit breaks.

Check tooth flanks of pinion for wear, indentations and chipping; if necessary recondition or replace starter.

Check condition of nuts and studs and check thread for ease-of-movement; replace as necessary.

Replace gasket.

C 172.05.10 Assembly

See Manufacturer’s Documentation.

C 172.05.11 Installation

Installing starter

Prior to installing starter, coat starter pinion with long-lasting lubricant grease.

Mount starter with hex nuts and washers as shown in General View – see C 172.05.01 and tighten hex nuts to specified tightening torque.

Connect lines to starter, ensuring that lines to starter are correctly laid!

Connect battery ground strap.

C 172.05.12 After-Installation Operations

A distinction must be made as to whether:

- 1 ————— The engine is to be completely disassembled
- 2 ————— The engine is to be removed but not disassembled
- 3 ————— The engine is to remain installed

1	2	3	Operations	See
x	–	–	Perform operations as per Assembly Plan	B 005
x	–	–	Install engine	B 007
–	–	x	Release engine start	Operating Instructions

Contents

C 180	Lube Oil System
C 181.05	Lube oil pump with drive
C 181.05.01	General view
C 181.05.04	Before-removal operations
C 181.05.05	Removal
C 181.05.06	Disassembly
C 181.05.08	Inspection and repair
C 181.05.10	Assembly
C 181.05.11	Installation
C 181.05.12	After-installation operations
C 182.10	Oil filler pipe, oil dipstick
C 181.10.01	General view
C 181.10.04	Before-removal operations
C 181.10.05	Removal
C 181.10.08	Inspection and repair
C 181.10.11	Installation
C 181.10.12	After-installation operations
C 183.05	Oil filter, oil heat exchanger
C 183.05.01	General view
C 183.05.02	Special tool
C 183.05.04	Before-removal operations
C 183.05.05	Removal
C 183.05.08	Inspection and repair
C 183.05.11	Installation
C 183.05.12	After-installation operations
C 184.10	Oil System in crankcase
C 184.10.01	General view
C 184.10.02	Special tool
C 184.10.04	Before-removal operations
C 184.10.05	Removal
C 184.10.08	Inspection and repair
C 184.10.11	Installation
C 184.10.12	After-installation operations

C 185.10 Oil supply lines for turbocharger

- C 185.10.01 General view
- C 185.10.04 Before-removal operations
- C 185.10.05 Removal
- C 185.10.08 Inspection and repair
- C 185.10.11 Installation
- C 185.10.12 After-installation operations

C 185.25 Oil return lines for exhaust turbocharger

- C 185.25.01 General view
- C 185.25.04 Before-removal operations
- C 185.25.05 Removal
- C 185.25.08 Inspection and repair
- C 185.25.11 Installation
- C 185.25.12 After-installation operations

C 180 Lube Oil System

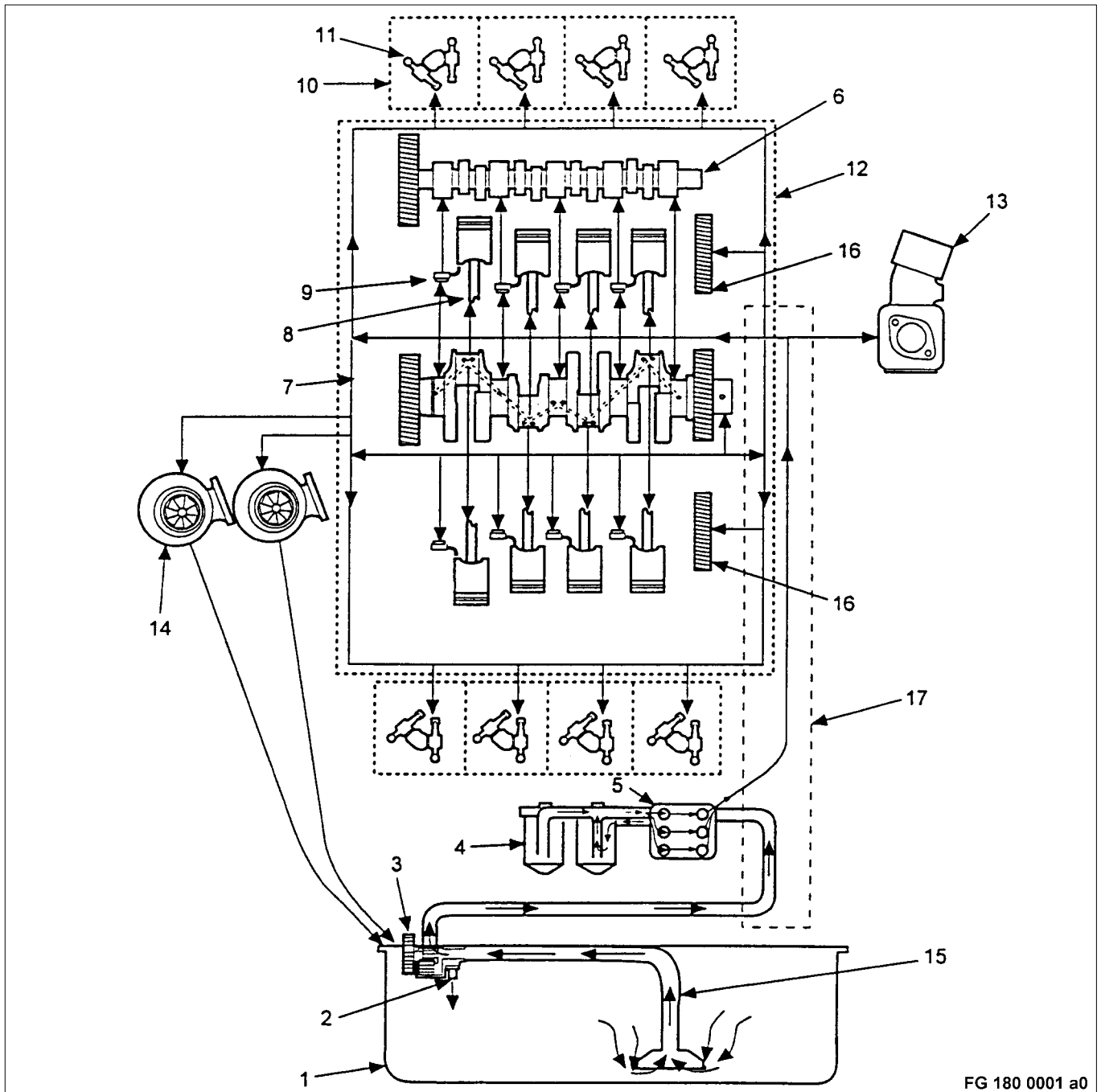

FG 180 0001 a0

- | | | |
|-----------------------------|------------------------------|-------------------------|
| 1 Oil pan | 7 Crankshaft | 13 Air compressor |
| 2 Oil pressure relief valve | 8 Connecting rod with piston | 14 Exhaust turbocharger |
| 3 Oil pump | 9 Oil spray nozzle | 15 Oil suction line |
| 4 Oil filter | 10 Cylinder head | 16 Idler gears |
| 5 Oil heat exchanger | 11 Rocker arm | 17 Gear case |
| 6 Camshaft | 12 Crankcase | |

The following is a list of auxiliary equipment and materials needed for the assembly operations:

	CAUTION
<p>When using these chemical substances, it is essential to observe the Manufacturer's Instructions for use, safety instructions and waste disposal specifications.</p>	

Materials and consumables	Designation	Order No.		Remarks
		MTU	DDC	
Emery cloth				
Magnifying glass				
Spray gun				
Inspection lamp				
Vaseline	Petroleum jelly, white	40317		
Engine oil				
Activator	Loctite No. 7649	50548		
Thread-sealing compound	Loctite No. 586	40033		Final strength at 20 °C - 12 hrs
Kerosene or diesel fuel				
Decalcifying agent	Porodox or Porozink			
Cooler cleaning agent (oil side)	P3 FD solution			
Corrosion preventive	Pfinder AP 11 F	40355		
Preservation agent	Branol 32/10			
Cleaning agent	Solvclean KW	40022		
Engineer's blue	blue	40641		
Antifriction bearing grease	Texando F020	50107		
Denaturated ethanol		40250		
Sealing paste	Elastosil	50545		
Multipurpose grease	Shell Retinax A	40333		
Corrosion preventive	Caramba Express	40008		
Dry compressed air				
Surface crack-testing equipment with red penetrant dye				
Magnetic crack-testing equipment with fluorescent magnetic powder				

C 181.05 Lube Oil Pump with Drive

C 181.05.01 General View

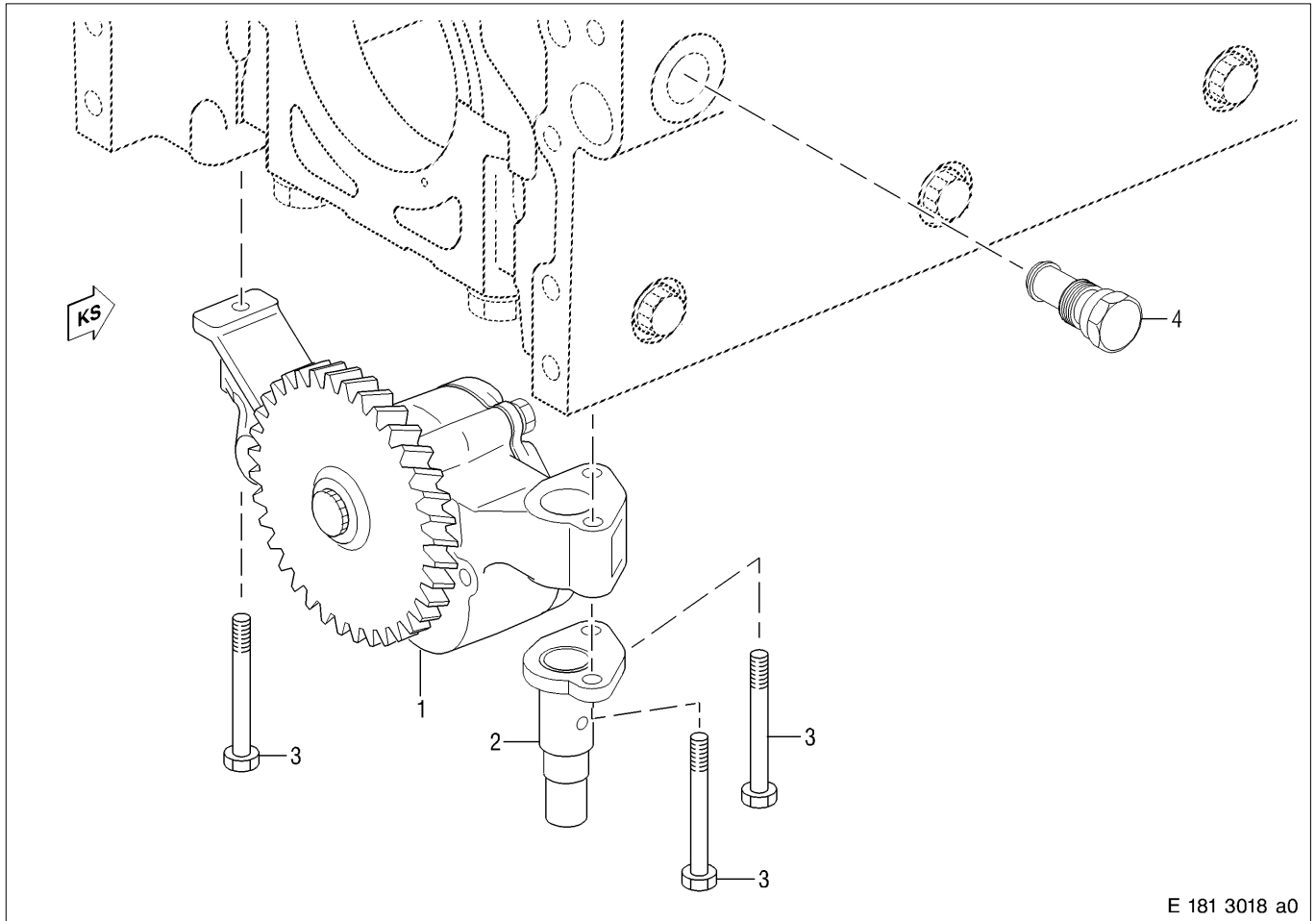

- 1 Oil pump
- 2 Pressure limiting valve
- 3 Hex screw
Tightening torque: 32 Nm
Lubricant: Engine oil

- 4 Non-return valve with sealing ring
Tightening torque: 100 Nm
Lubricant: Engine oil

Suction line

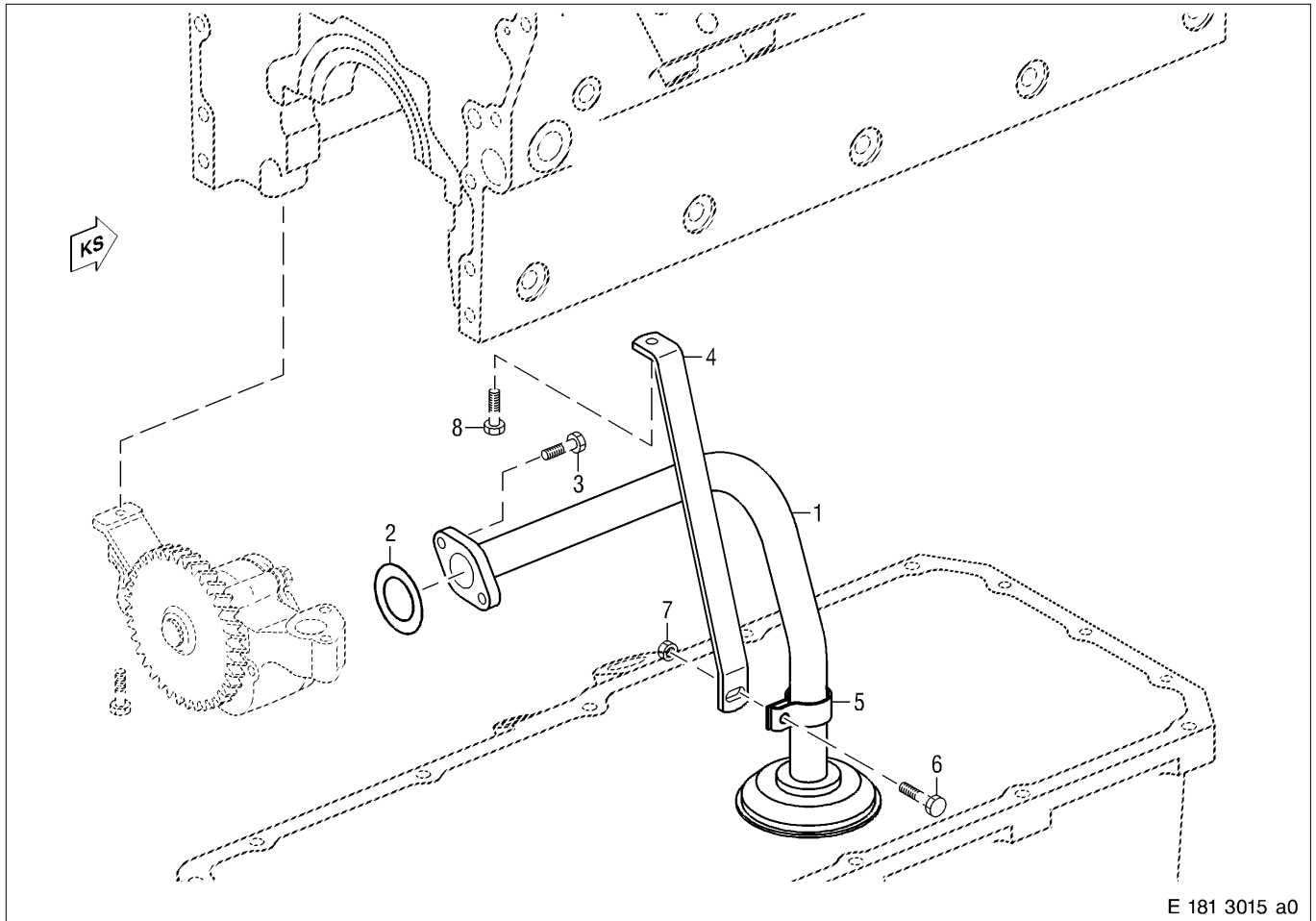

- | | |
|--------------------------|-------------|
| 1 Oil suction line | 5 Clamp |
| 2 Gasket | 6 Hex screw |
| 3 Hex screw | 7 Nut |
| Tightening torque: 35 Nm | 8 Hex screw |
| Lubricant: Engine oil | |
| 4 Bracket | |

Oil pump

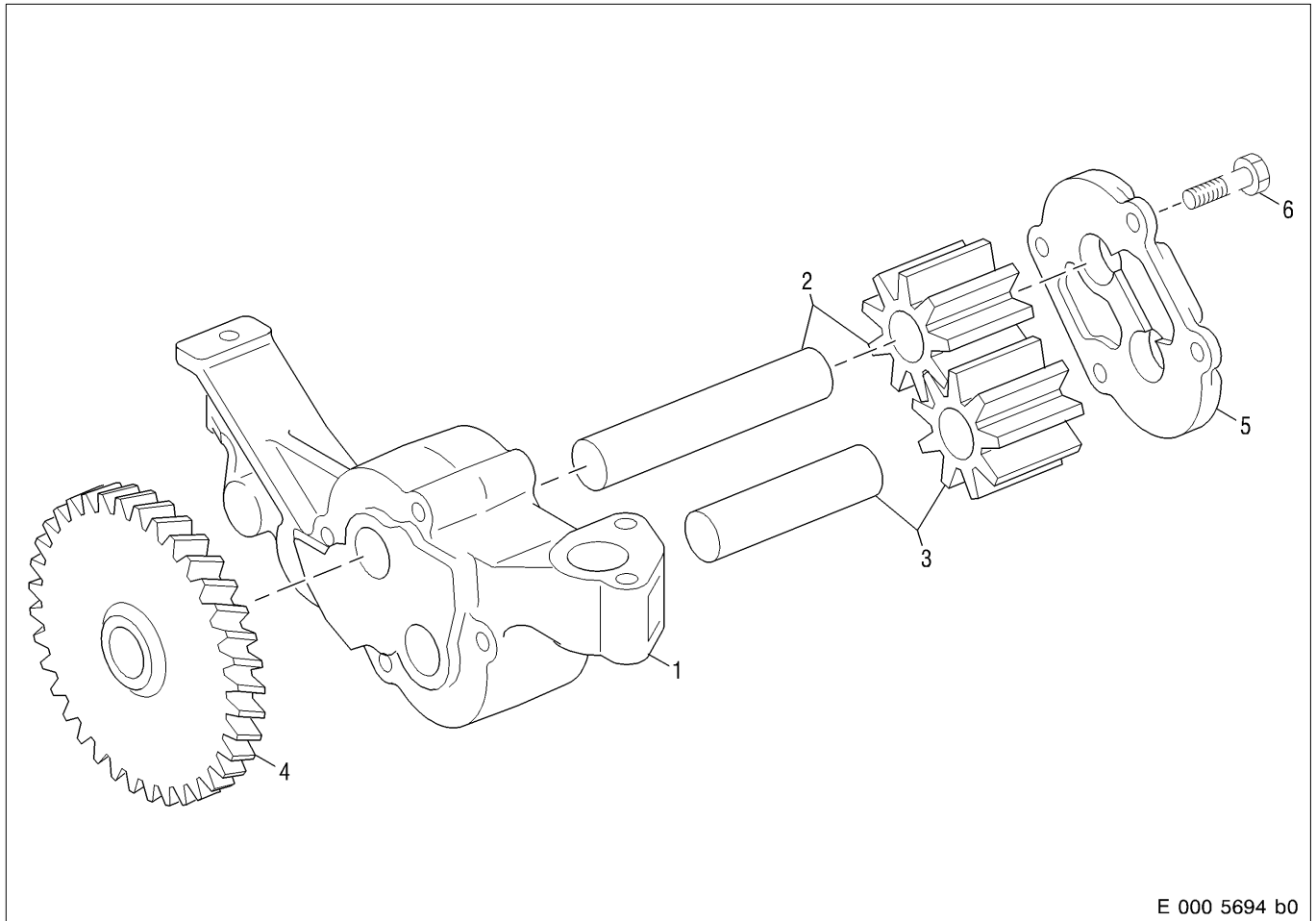

E 000 5694 b0

- | | |
|--------------------------|--------------------------|
| 1 Oil pump housing | 5 Cover |
| 2 Oil pump gear, driving | 6 Hex screw |
| 3 Oil pump gear, driven | Tightening torque: 25 Nm |
| 4 Drive gear | Lubricant: Engine oil |

C 181.05.04 Before-Removal Operations

A distinction must be made as to whether:

- 1 ————— The engine is to be completely disassembled
- 2 ————— The engine is to be removed but not disassembled
- 3 ————— The engine is to remain installed

1	2	3	Operations	See
x	-	-	Remove engine	B 003
x	-	-	Perform operations as per Disassembly Plan	B 004
-	-	x	Disable engine start	Operating Instructions
-	-	x	Drain or draw off engine oil	Operating Instructions
-	x	x	Removing oil pan	C 014.05

C 181.05.05 Removal

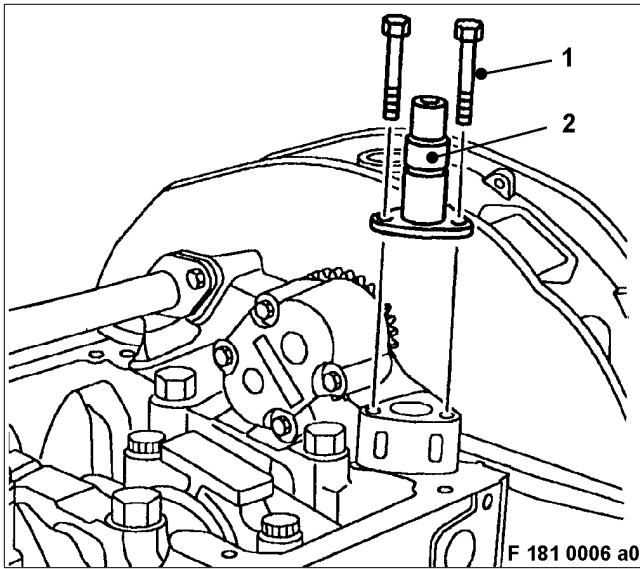

Removing oil pressure relief valve

Remove hex bolts (1) for oil pressure relief valve (2) and remove oil pressure relief valve.

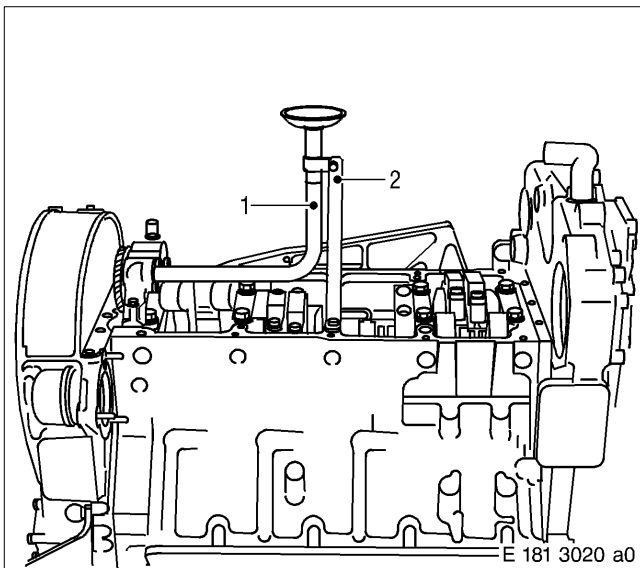

Removing oil suction line

Remove bracket (2) and clamp.
Remove hex bolts for oil suction line (1) from oil pump and disconnect oil suction line.
Remove gasket.

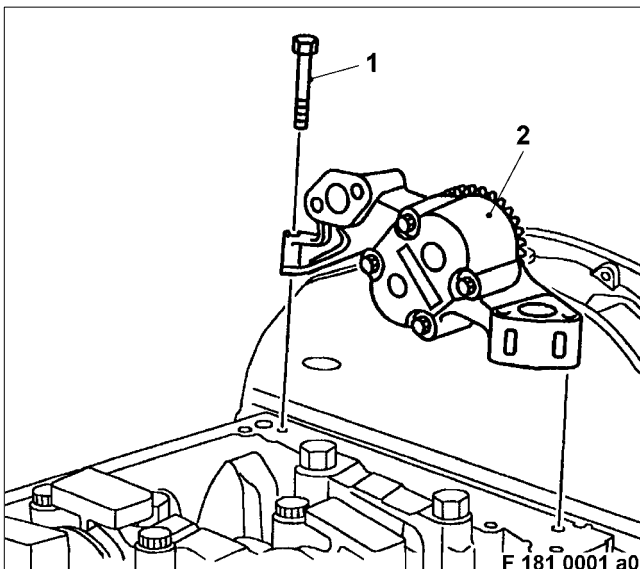

Removing oil pump

Remove hex bolt (1) for oil pump (2) and remove oil pump from crankcase.

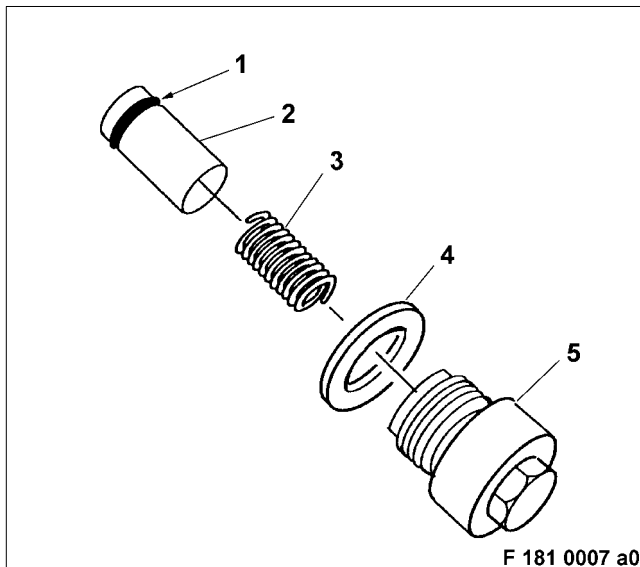

Removing non-return valve

Remove non-return valve from crankcase as shown in General View – see C 181.05.01.

Remove piston (2) and O-ring (1), spring (3) and sealing ring (4) from plug (5).

If necessary, cover installation bore or seal with a suitable plug.

C 181.05.06 Disassembly

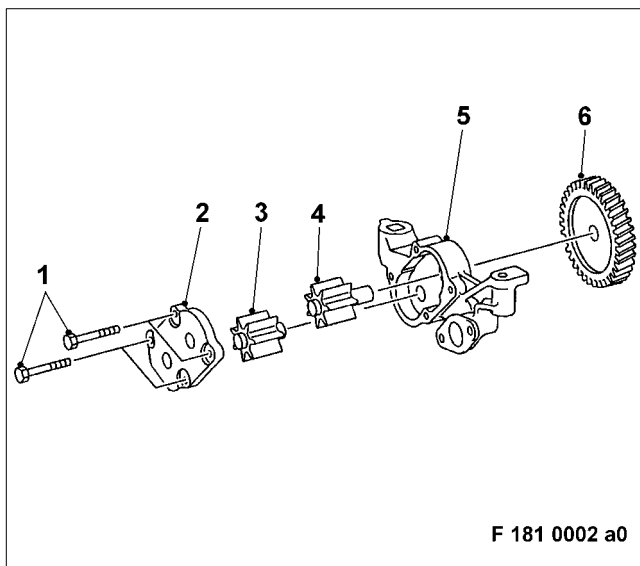

Disassembling oil pump

Remove hex screws (1) and remove cover (2).

Remove driven gear (3) from oil pump housing (5).

Press driving gear (4) out of drive gear (6) – see next illustration.

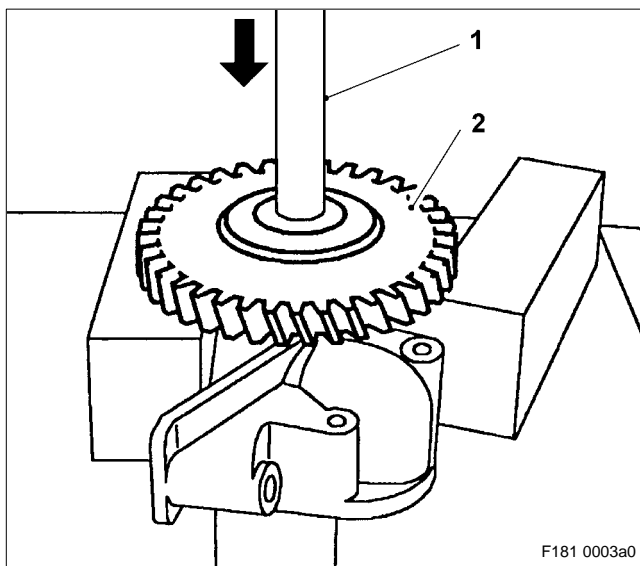

Using manual press and suitable mandrel (1), press driving gear out of drive gear (2) (arrow).

Use soft supports!

C 181.05.08 Inspection and Repair

Oil suction line

Clean all components.



CAUTION

Compressed air is air which has been compressed under pressure. If compressed air is used for blowing out or blow-drying components, always wear protective goggles or safety mask. Compressed air must not be directed at the body. The pressure must not exceed 3.0 bar (40 lb/in²).

Clean oil suction lines with cold cleaner and blow clear with compressed air.

Visually inspect components for condition and damage; recondition as necessary or replace.

Machine defective sealing face and check for surface irregularities with ink-check plate.

Check securing screws and nut for condition and thread for ease of movement; replace components as necessary.

Replace gasket.

Note: Make sure parts are perfectly clean.

Oil pump

Clean all components.

Using the magnetic crack-testing method with fluorescent magnetic powder, check oil pump gears and drive gear for cracks.

Using the surface crack-testing method, check oil pump housing and cover for cracks.

Replace cracked components.

Check teeth of drive gear and oil pump gears for wear, indentations and chipping.

Remove minor wear, scoring and indentations by rubbing down with oilstone or emery paper or replace components.

Check all sealing, mating and sliding surfaces for wear, scoring and indentations; recondition or replace components as necessary.

Check oil pump housing for wear, remove slight scoring.

If scoring is deeper than 0.3 mm in oil chamber of oil pump housing, replace oil pump housing.

Check mating face of cover for surface irregularities; replace cover if necessary.

Check condition of threads in oil pump housing; rechase threads as necessary.

Measure bearing bush bore in cover and in oil pump housing with bore gauge.

Measure bearings on gears with micrometer

If limit values are exceeded, replace component.

For limit values, see Tolerances and Wear Limits List.

Check securing screws for condition and thread for ease of movement; replace screw if necessary.

Note: Ensure that all components are perfectly clean.

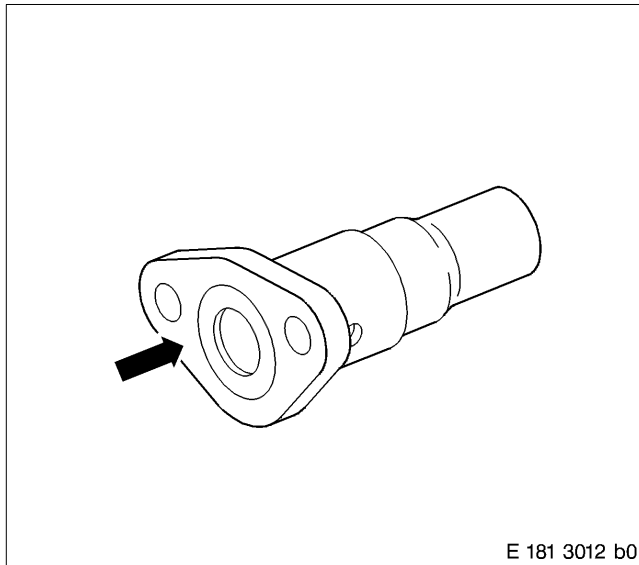

Oil pressure relief valve

Note: Do not disassemble oil pressure relief valve!

Visually inspect oil pressure relief valve for damage and defects; replace if necessary.

Check sealing surface (arrow) for evenness; smooth with oilstone if necessary.

Max. permissible irregularity = 0.2 mm

WARNING
<p>Test fluid is highly pressurised. Risk of injury. Liquids emerging under high-pressure can lead to serious injury! Always wear protective clothing, protective gloves and protective goggles/safety mask.</p>

Check pressure relief valve for opening pressure of 8.5 bar \pm 0.7 bar. If values are above or below opening pressure, replace pressure relief valve.

Non-return valve

Clean individual components of non-return valve.

Visually inspect components for condition and damage; replace non-return valve if damaged.

Especially check piston, O-ring and spring for wear; in event of wear, replace non-return valve.

Check thread of plug for ease of movement; recondition as necessary or replace non-return valve.

Note: Ensure that all components are perfectly clean.

C 181.05.10 Assembly

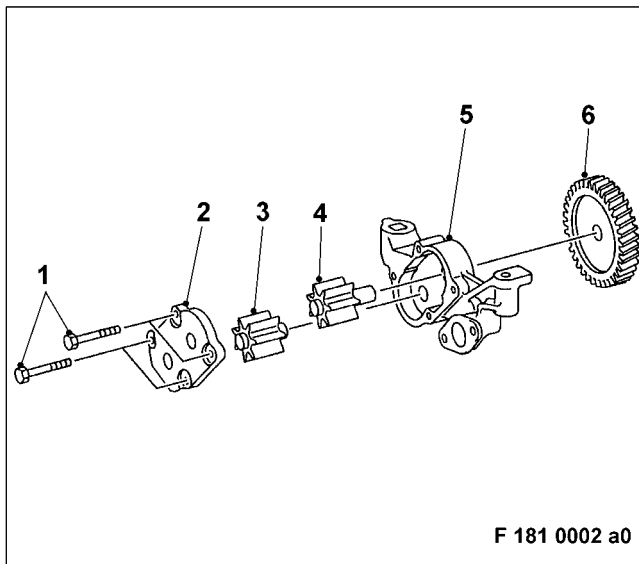

Assembling oil pump

Note: Make sure parts are perfectly clean.

Check sealing surfaces on cover (2) and on oil pump housing (5) and clean as necessary.

Coat all moving parts and friction faces with oil.

Insert driven gear (3) and driving gear (4) in oil pump housing.

Using feeler gauge, check backlash of oil pump gears.

Required backlash = from 0.312 mm to 0.476 mm

If backlash exceeds or drops below specified values, check oil pump housing and oil pump gears in accordance with Tolerances and Wear Limits List.

Mount cover (2) with hex bolts (1).

Tighten hex screws in diagonally opposite sequence to specified torque – see C 181.05.01.

Mount drive gear (6) – see next illustration.

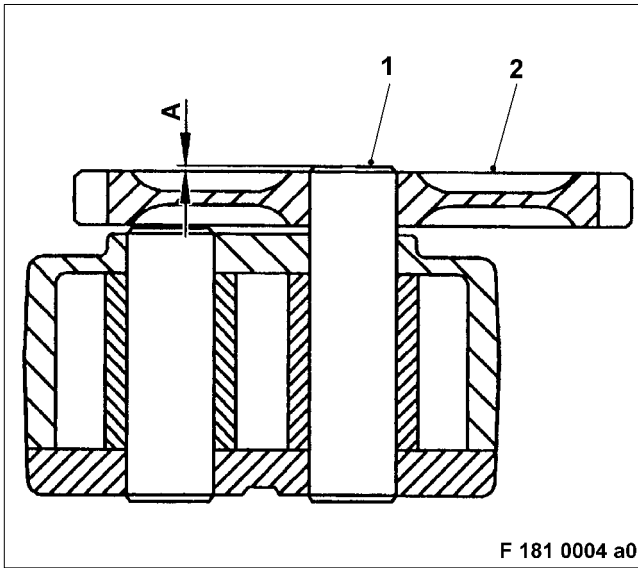

Measure diameter of bore in drive gear (2) with bore gauge.

Using micrometer, measure outside diameter of drive shaft (1).

Ensure that contact between both components is in accordance with Tolerances and Wear Limits List.

CAUTION
Component is hot. Risk of injury! Touch components only when wearing protective gloves.

Heat drive gear to approx. 80 °C.

Fit drive gear on drive shaft, maintaining clearance (A) of 0.5 mm .

Then turn drive gear to check ease of movement; drive gear must be easily turned.

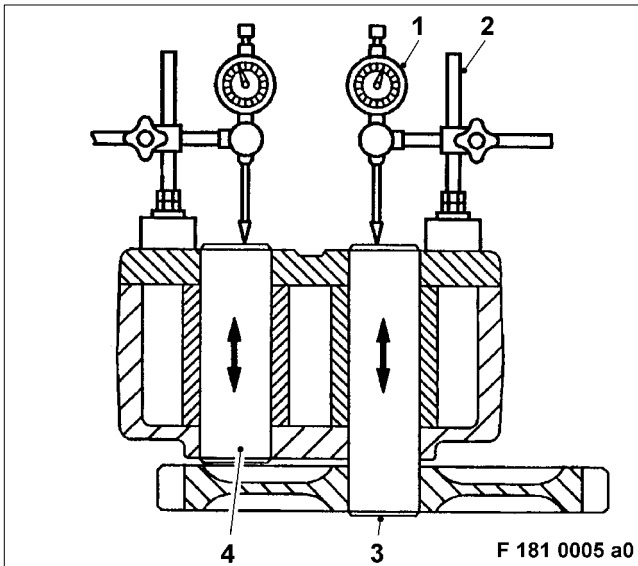

Measuring axial play of oil pump gears

Mount magnetic-base indicator holder (2) with dial gauge (1) on oil pump housing.

Mount dial gauge stylus with preload on front of shaft (3) and (4) of oil pump gear and set dial gauge to zero.

Measure axial clearance by axially moving oil pump gear (arrows).

If setpoint axial clearance drops below or exceeds specified value – see Tolerances and Wear Limits List – replace or repair oil pump.

C 181.05.11 Installation

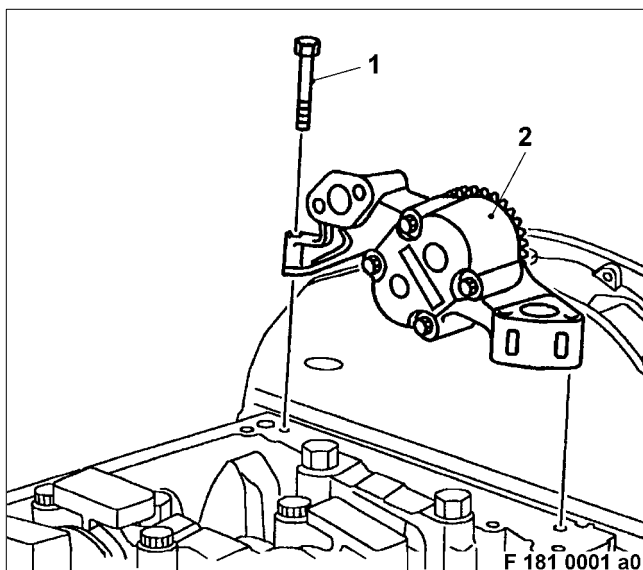

Mounting oil pump

Note: When performing any tasks ensure that components are perfectly clean!

Clean sealing surfaces on oil pump (1) and on crankcase.

Mount oil pump on crankcase, ensuring gear engages.

Insert hex bolt (2) for oil pump; fit but do not tighten.

Note: Tighten hex bolts for oil pump diagonally and evenly only once oil pressure relief valve has been installed – see following sections.

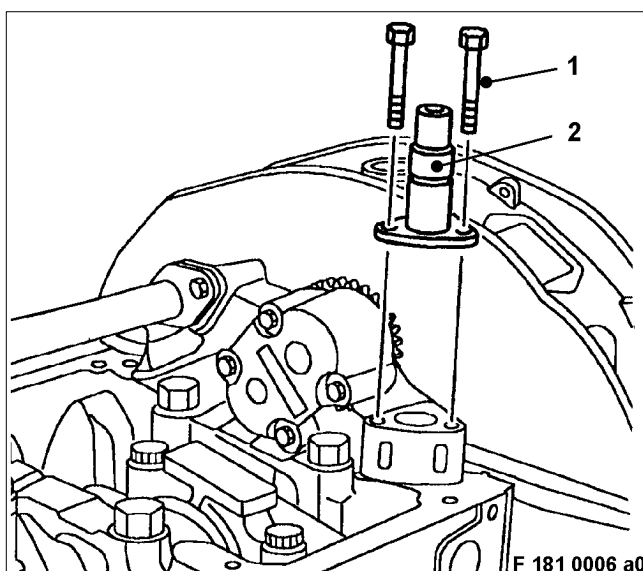

Installing oil pressure relief valve

Clean sealing surfaces.

Mount oil pressure relief valve (2) with hex bolts (1) on oil pump.

Tighten hex bolts for oil pump and for oil pressure relief valve diagonally and evenly to specified tightening torque – see C 181.05.01.

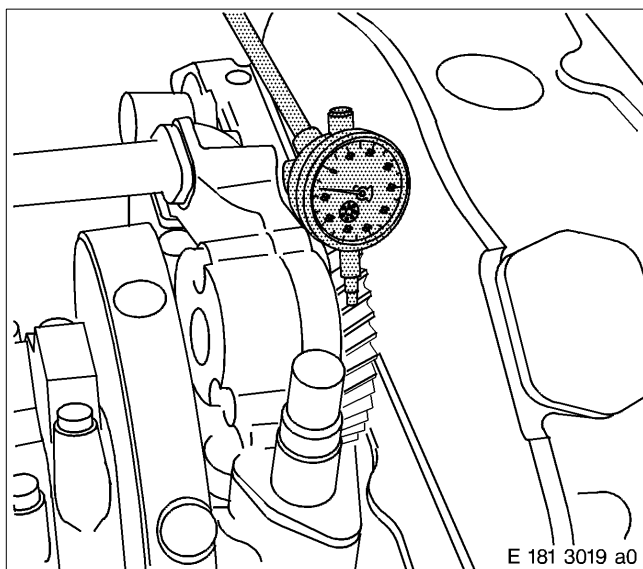

Measuring backlash

Mount magnetic dial gauge holder with dial gauge on crankcase.

Vertically fit dial gauge stylus with small preload on a tooth flank of oil pump gear.

Set dial gauge to zero.

Check backlash by moving oil pump gear back and forth.

For backlash, see C 020.

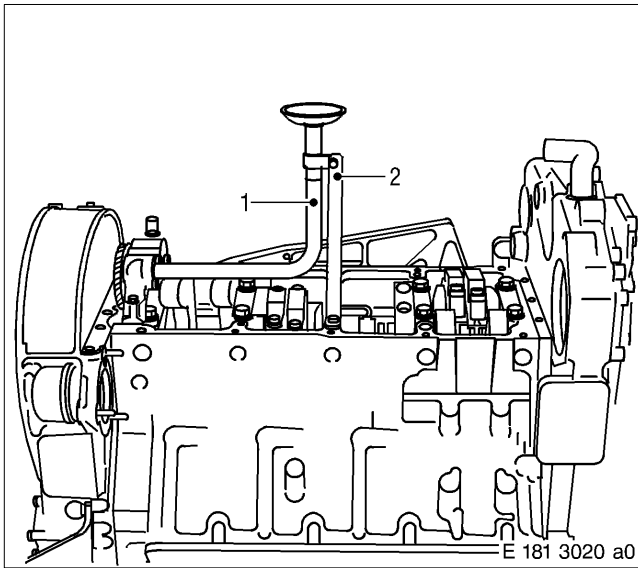

Installing oil suction line

CAUTION

Compressed air is air which has been compressed under pressure. Risk of injury. If compressed air is used for blowing out or blow-drying components, always wear protective goggles or safety mask. Compressed air must not be directed at the body. The pressure must not exceed 3.0 bar (40 lb/in²).

Blow oil suction line (1) through with compressed air and make sure they are perfectly clean.

Fit new gasket and install oil suction line with hex bolts on oil pump.

Tighten hex bolts as shown in General View – see C 181.05.01 – to specified tightening torque.

Mount bracket (2) free of tension as shown in General View.

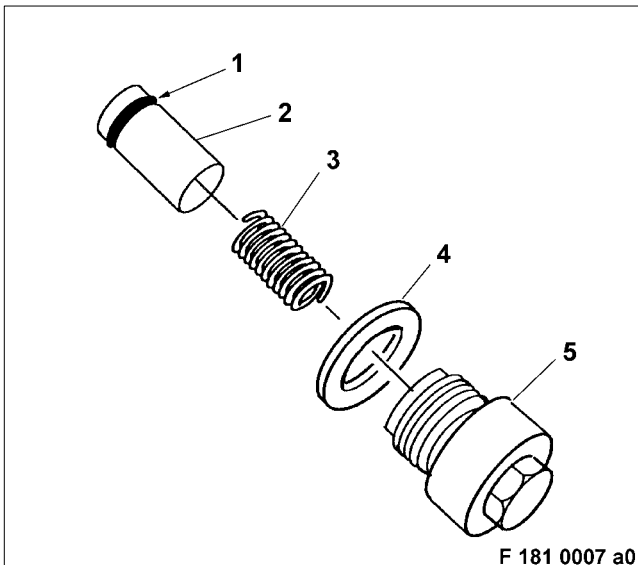

Installing non-return valve

Note: Prior to installation, remove blanking plug and/or cover.

Ensure sealing surface and oil bore in crankcase are perfectly clean; clean as necessary.

Coat O-ring (1) with petroleum jelly and fit on piston (2).

Fit sealing ring (4) on plug (5).

Coat piston (2) and compression spring (3) with engine oil and insert into plug.

Insert non-return valve into crankcase – see C 181.05.01 – and tighten to specified tightening torque.

Note: After starting engine, visually inspect non-return valve in crankcase for leaks.

C 181.05.12 After-Installation Operations

A distinction must be made as to whether:

- 1 ————— The engine was completely disassembled
- | 2 ————— The engine is removed but was not disassembled
- | | 3 — The engine is installed
- | | |

1	2	3	Operations	See
x	-	-	Perform operations as per Assembly Plan	B 005
x	-	-	Install engine	B 007
-	x	x	Install oil pan	C 014.05
-	-	x	Fill oil system with engine oil	Operating Instructions
-	-	x	Release engine start	Operating Instructions



C 182.10 Oil Filler Pipe, Oil Dipstick

C 182.10.01 General View

Oil filler pipe

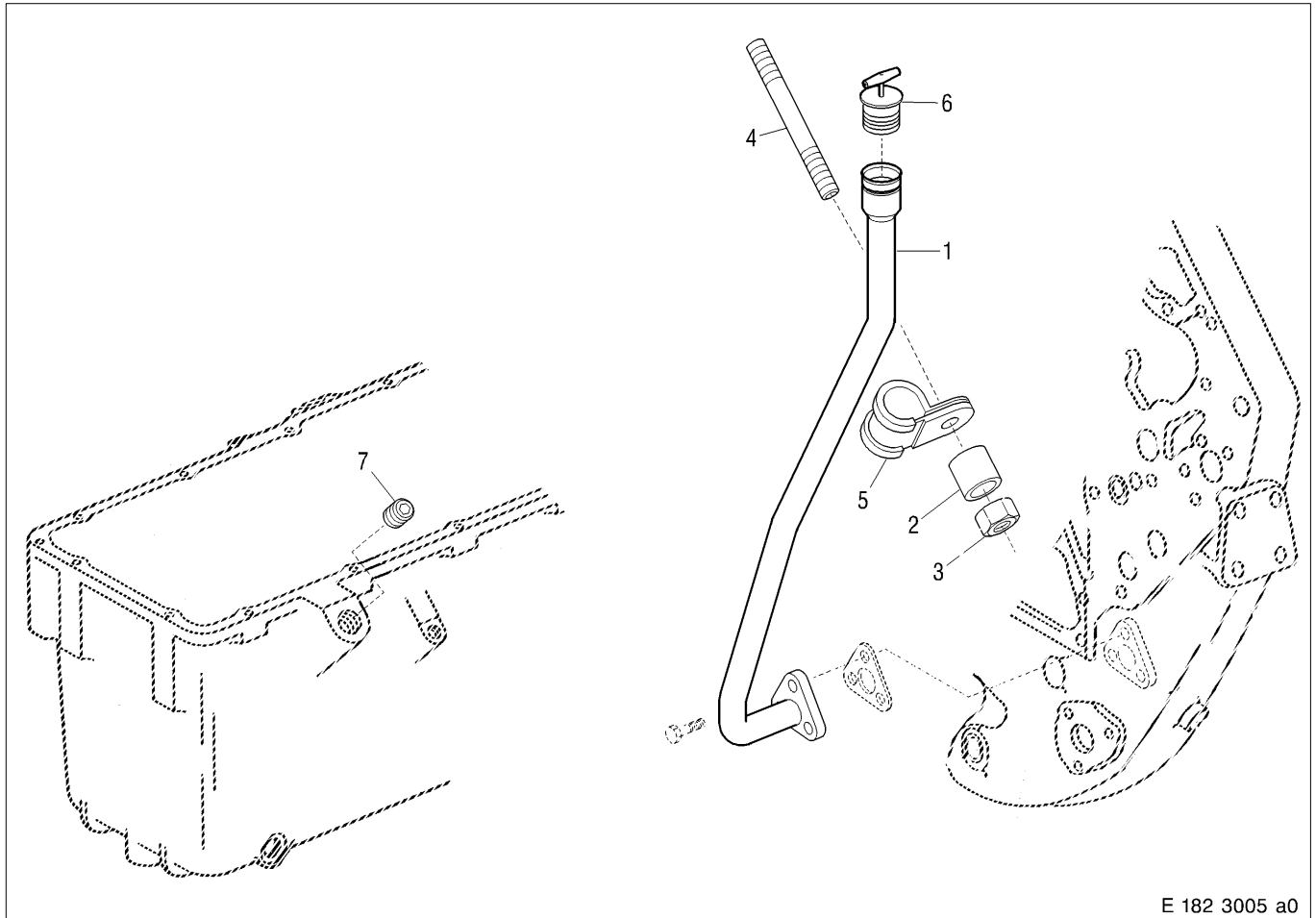

- 1 Oil filler pipe
- 2 Spacer
- 3 Nut
- 4 Stud

- 5 Clamp
- 6 End cover
- 7 Plug

Oil dipstick

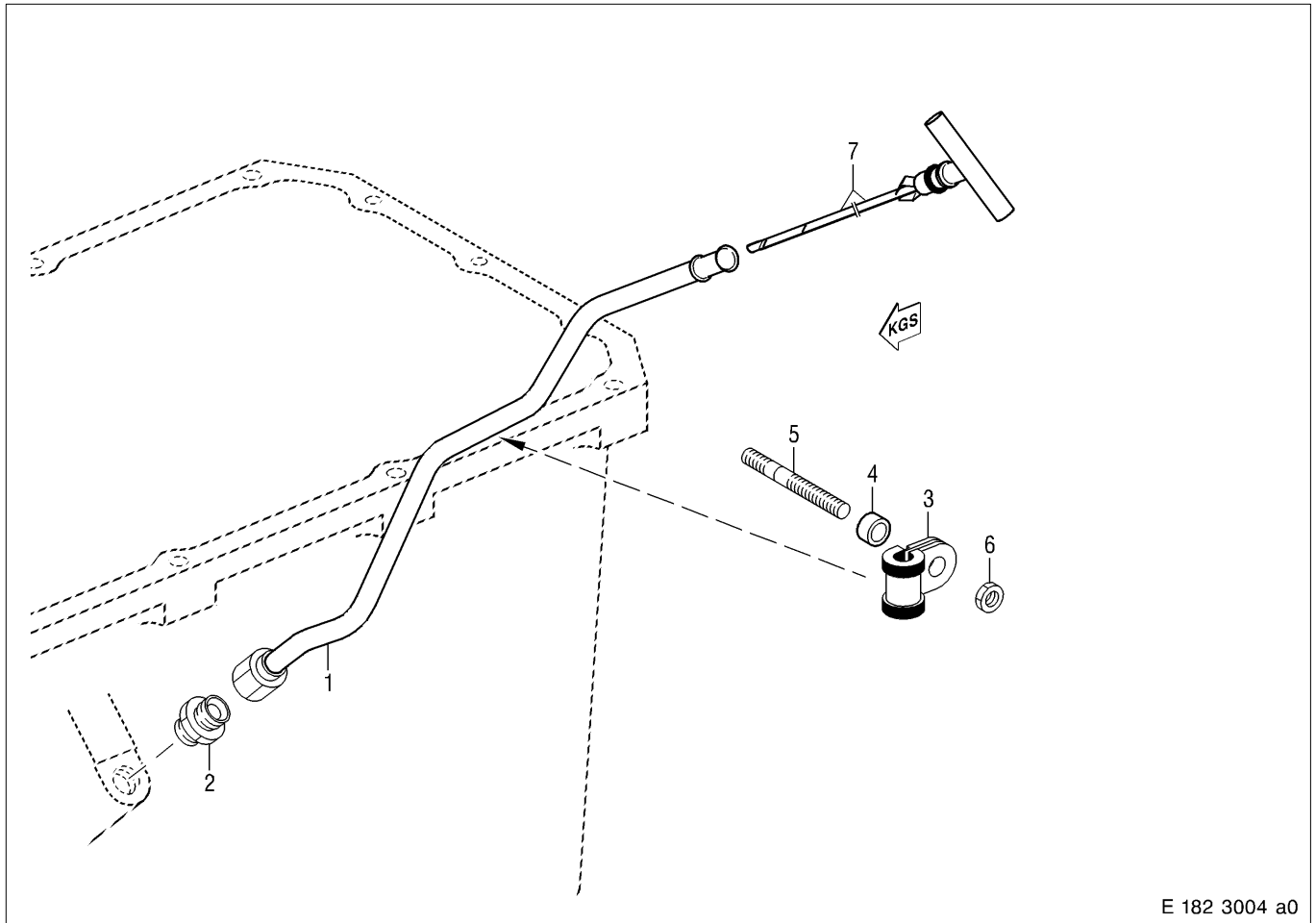

- | | | | |
|---|------------|---|--------------|
| 1 | Guide tube | 5 | Stud |
| 2 | Connector | 6 | Nut |
| 3 | Clamp | 7 | Oil dipstick |
| 4 | Spacer | | |

C 182.10.04 Before-Removal Operations

A distinction must be made as to whether:

- | | | |
|----------|-------|--|
| 1 | ————— | The engine is to be completely disassembled |
| 2 | ————— | The engine is to be removed but not disassembled |
| 3 | ————— | The engine is to remain installed |

1	2	3	Operations	See
x	—	—	Remove engine	B 003
x	—	—	Perform operations as per Disassembly Plan	B 004
—	—	x	Disable engine start	Operating Instructions

C 182.10.05 Removal

Removing oil filler pipe, oil dipstick

Remove oil dipstick, guide tube, oil filler pipe and attachments as shown in General View – see C 182.10.01.
After removal, cover installation bores as necessary or seal with suitable plug.

C 182.10.08 Inspection and Repair

Clean all components.



CAUTION

Compressed air is air which has been compressed under pressure. If compressed air is used for blowing out or blow-drying components, always wear protective goggles or safety mask. Compressed air must not be directed at the body.

Clean oil filler pipe and guide pipe with cold cleaner and blow clear with compressed air.

Visually inspect all components for damage and defects; replace if necessary.

Replace end cover, connector and plug only if necessary (e.g. due to leaks, damage).

Check condition of threads; machine or replace components as necessary.

Note: Make sure that oil-retaining parts are perfectly clean.

C 182.10.11 Installation

Installing oil filler pipe, oil dipstick

Note: Prior to installation, remove all blanking plug and/or covers. Make sure that oil-retaining components are perfectly clean.

Ensure sealing surfaces and oil bores of oil pan and in gear case, free end, are perfectly clean; clean if necessary.
Mount guide tube and oil filler pipe with attachments free of tension as shown in General View – see C 182.10.01 – and tighten.

Insert oil dipstick into guide tube.

C 182.10.12 After-Installation Operations

A distinction must be made as to whether:

- 1 — The engine was completely disassembled
- 2 — The engine is removed but was not disassembled
- 3 — The engine is installed

1	2	3	Operations	See
x	–	–	Perform operations as per Assembly Plan	B 005
x	–	–	Install engine	B 007
–	–	x	Release engine start	Operating Instructions



C 183.05 Oil Filter, Oil Heat Exchanger

C 183.05.01 General View

Oil filter (mounted on engine)

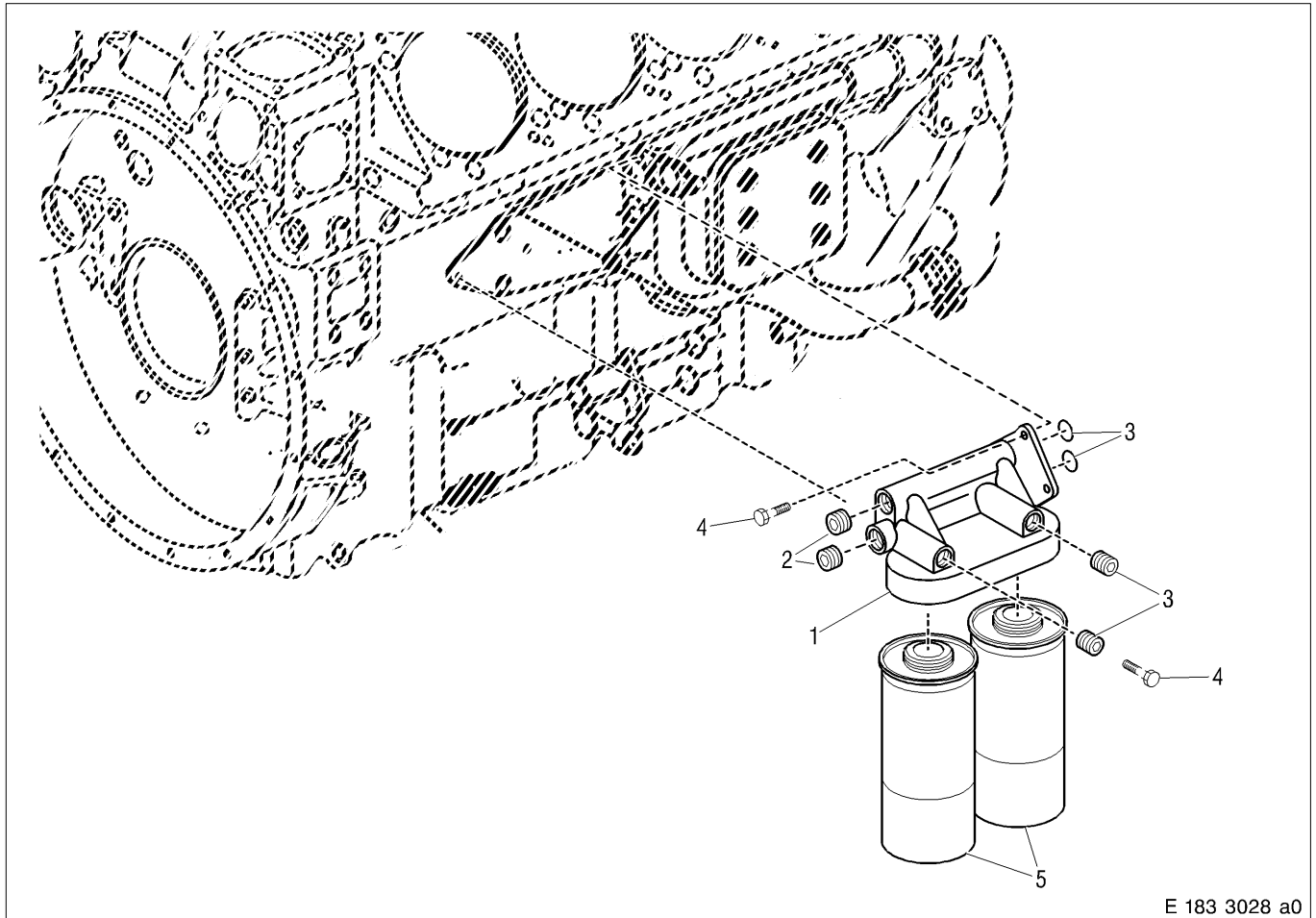

E 183 3028 a0

- | | |
|----------------------|--------------|
| 1 Oil filter housing | 4 Screw |
| 2 Plug | 5 Oil filter |
| 3 Sealing ring | |

Oil filter (not mounted on engine)

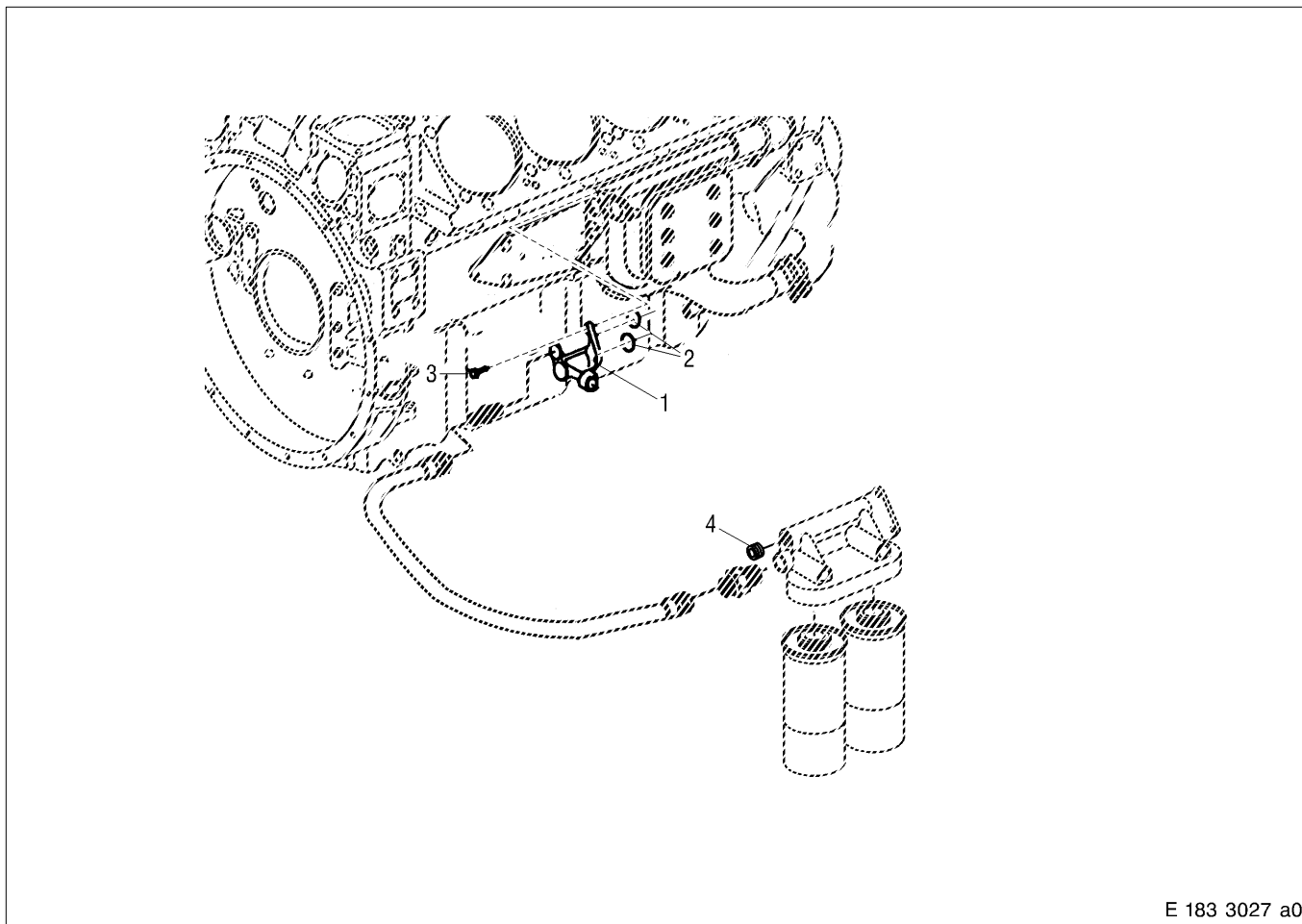

E 183 3027 a0

- 1 Intermediate element
- 2 Sealing ring

- 3 Screw
- 4 Plug

Oil heat exchanger

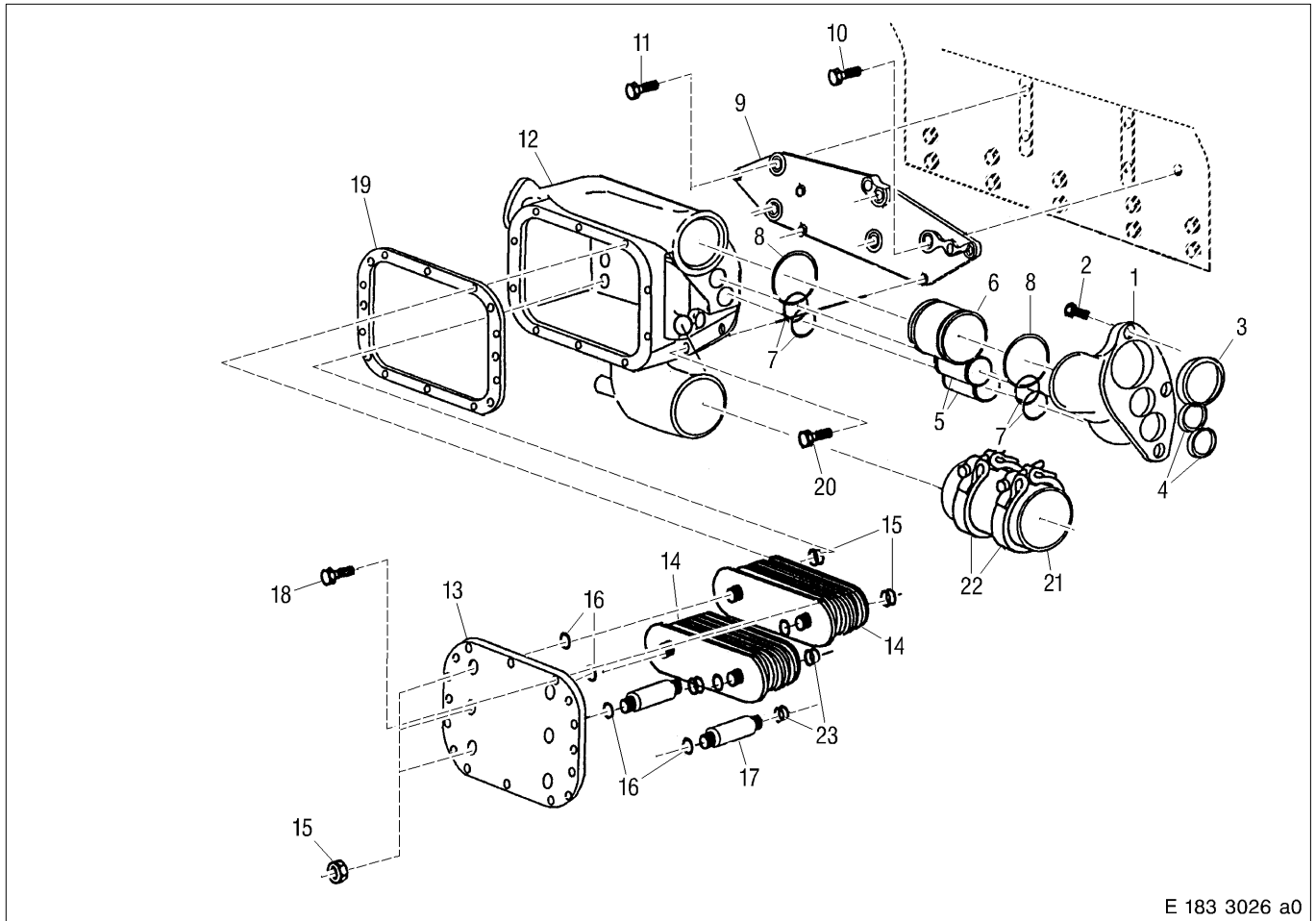

E 183 3026 a0

- | | | |
|----------------|---------------------------|--------------------------|
| 1 Housing | 10 Hex screw | 17 Stud |
| 2 Screw | 11 Screw | 18 Screw |
| 3 Sealing ring | 12 Oil cooler housing | Tightening torque: 35 Nm |
| 4 Sealing ring | 13 Cover | Lubricant: Engine oil |
| 5 Pipe | 14 Cooler insert | 19 Gasket |
| 6 Pipe | 15 Nut | 20 Screw |
| 7 Sealing ring | Tightening torque: 108 Nm | 21 Hose line |
| 8 Sealing ring | Lubricant: Engine oil | 22 Hose clamp |
| 9 Bracket | 16 Gasket | 23 O-ring |

Oil cooler housing

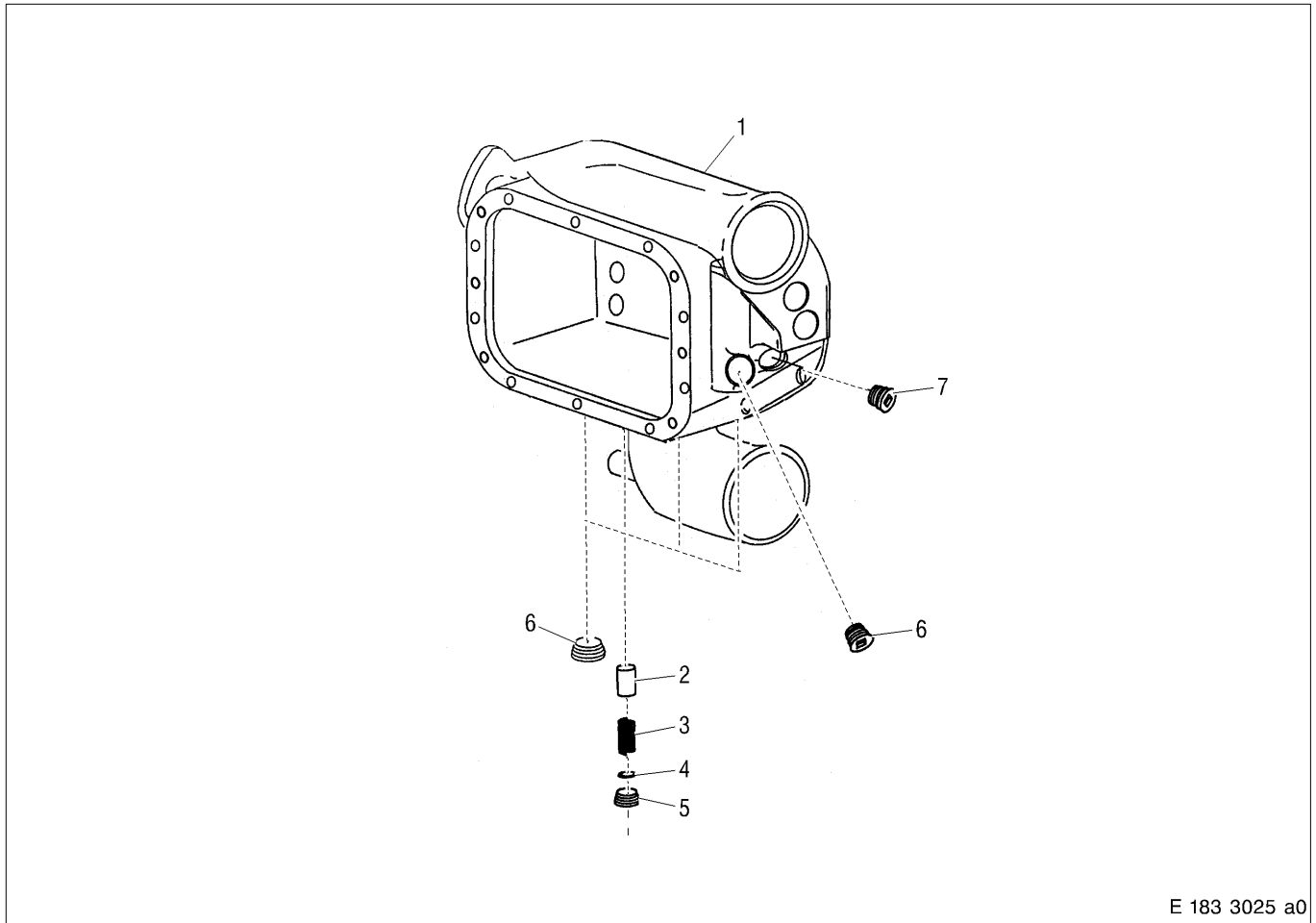

- 1 Housing
- 2 Bypass valve
- 3 Spring
- 4 Sealing ring
- 5 Blanking plug
- 6 Blanking plug
- 7 Blanking plug

C 183.05.02 Special Tool

Designation – Application	Number
Strap wrench for oil filter	1

C 183.05.04 Before-Removal Operations

A distinction must be made as to whether:

- 1 ————— The engine is to be completely disassembled
- 2 ————— The engine is to be removed but not disassembled
- 3 ————— The engine is to remain installed

1	2	3	Operations	See
x	–	–	Remove engine	B 003
x	–	–	Perform operations as per Disassembly Plan	B 004
–	–	x	Disable engine start	Operating Instructions
–	–	x	Drain engine coolant*	Operating Instructions
–	x	x	Drain engine oil from oil heat exchanger*	–
–	x	x	Remove coolant lines from oil heat exchanger*	C 202.15

*–only when removing oil heat exchanger –

C 183.05.05 Removal

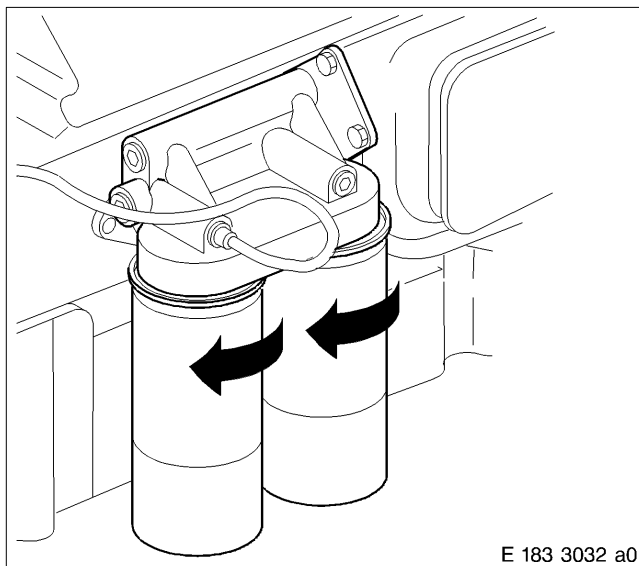

Removing oil filter

Remove oil filter cartridges with strap wrench (arrows) and dispose of in accordance with local regulations.

Use a cloth to collect or wipe up remaining oil from oil collecting bowl.

Remove oil filter housing as shown in General View – see C 183.05.01.

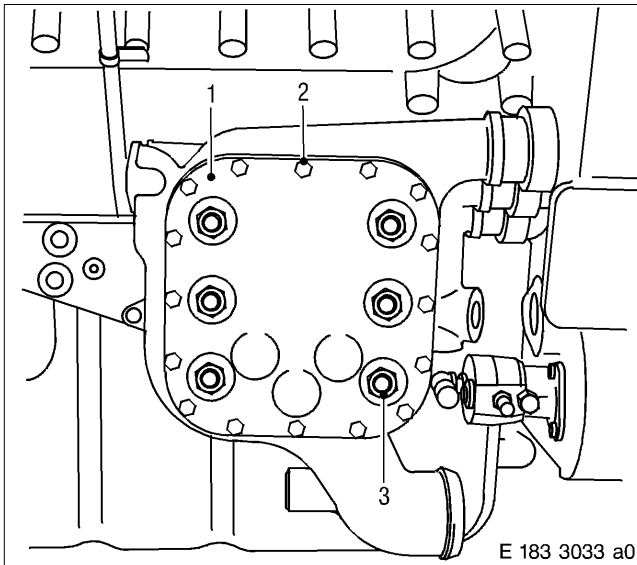

Removing oil heat exchanger

Remove all screws (2) and nuts (3) from cover (1).
Remove cover and gasket.

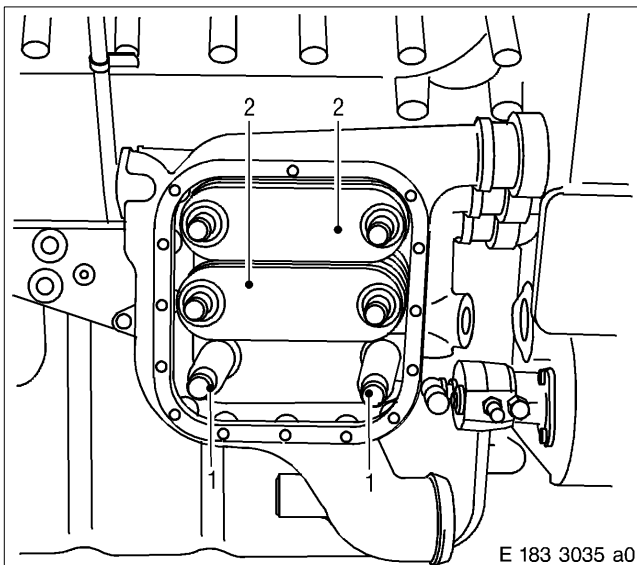

Remove stud (1) and cooler element (2) from oil cooler housing.

Remove O-rings and gaskets from stud and cooler inserts.

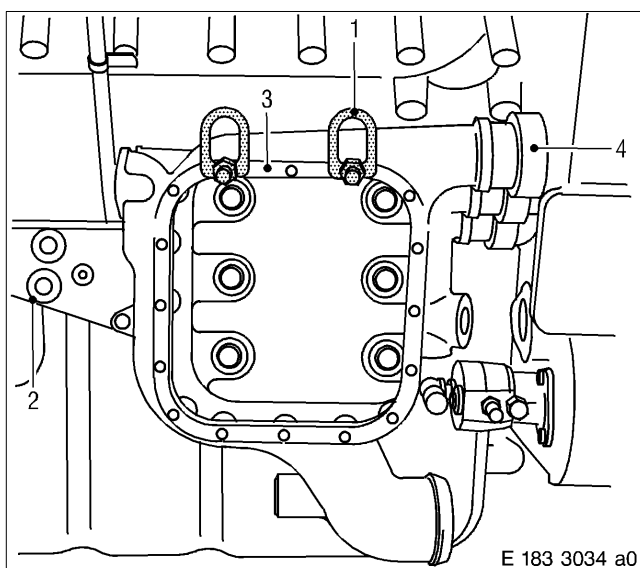

! WARNING

**Heavy object.
Risk of injury!
Use suitable tools and lifting equipment.**

Attach oil cooler housing (3) to lifting eyes (1), rope and crane, ensuring that ropes are all equally tensioned.

Remove all screws for oil cooler housing.

Remove oil cooler housing with rope and crane from crankcase, paying special attention to fit of plug-in pipes.

Remove housing (4) and bracket (2) as shown in General View – see C 183.05.01.

If necessary, seal oil bores in crankcase with suitable blanking plugs.

Remove blanking plug for bypass valve in oil cooler housing – see General View C 183.05.01 – and remove sealing ring, spring and valve.

C 183.05.08 Inspection and Repair

Replace oil filter cartridges.

Clean all components.

Check components for damage; machine or replace as necessary.

Replace cooler insert in event of damage.

Using the surface crack-testing method with red penetrant dye, check retainer for oil cooler housing, oil cooler housing and oil filter housing for cracks. If cracks are detected, replace part.

Check all sealing, mating and sliding surfaces for wear, scoring and indentations.

Remove minor wear, scoring and indentations by rubbing down with oilstone or emery paper; replace components as necessary.

Check condition of threads; rechase threads or replace component if necessary.

Replace blanking plugs and plugs if necessary (e.g. if leaking) .

Replace hose line as part of every W6 overhaul.

Replace gaskets, sealing rings, gasket and O-rings.

Make sure that oil chambers and oilways are perfectly clean.

Clean cooler inserts on coolant and oil side.

Note: The oil heat exchanger must be replaced if chippings have penetrated the engine oil system e.g. in event of piston scuffing or damage to bearings.

Cleaning coolant side:

It is essential to examine extent of contamination of coolant side prior to cleaning.

The coolant side must be cleaned if there is visible encrustation on the coolant side due to crustations, contamination and oil deposits.

Soak cooler element in a cleaning bath containing dissolved cleaning agent.



CAUTION

When using these chemical substances, it is essential to observe the Manufacturer's Instructions for use, safety instructions and waste disposal specifications.

An agent which is not aggressive to metal surfaces (e.g. Porodox from Henkel or Porozink from Parobe-Chemie, Basel) must be used to remove deposited material.

Follow the manufacturer's instructions to the letter when preparing the descaling solution.

Dwell time depends on the condition and temperature of the solution and the nature and stubbornness of the deposits.

Cleaning process is completed when loosened contaminants can be flushed away with a powerful water jet.

After cleaning, flush the cooler with water until pH values of clean water and rinsing water are approximately the same (difference 1 pH).

Normal coolant can be used for flushing purposes.

Cleaning/flushing oil side:

Connect oil side to sealed, forced-circulation flushing system.

Forced-circulation flushing system must be equipped with a filter (0.05 mm mesh).

Flush with cleaning agent in opposite direction of oil flow in normal operation.



CAUTION

When using these chemical substances, it is essential to observe the Manufacturer's Instructions for use, safety instructions and waste disposal specifications.

Suitable descaling agents are buffered alkaline agents such as a 3 to 5% solution of P3 FD from Henkel.

Cleaning can be improved by using ultrasonic equipment.

After cleaning, oil side must be flushed with water until pH values of fresh water and flushing water are roughly equal (permissible difference 1pH).

This releases contaminants, particularly particles from wear parts, from swirl plates, so that they are flushed out with water.

Continue cleaning process until flushing medium leaving cooler is same as that entering.



WARNING

Test fluid is highly pressurized. Risk of injury.

Liquids emerging under high-pressure can lead to serious injury!

Always wear protective clothing, protective gloves and protective goggles/safety mask.

Flushing pressure 3 to 4 bar at 150 to 300 litres/minute.

Note: If the cooler is not put into operation immediately, dry oil side, preserve and seal the openings air-tight with suitable end covers.

Dry in a drying oven between 110 °C and 120 °C. Oven drying time: approx. 3 hours.

Spray preservation agent (Branol 32/10 from Brangs and Heinrich) into cooler. The preservation agent condenses and falls to form a protective layer over the inner surfaces.

Make sure dosages are correct! 2 ml Branorol 32/10 per litre of coolant.

Cooler insert leak check

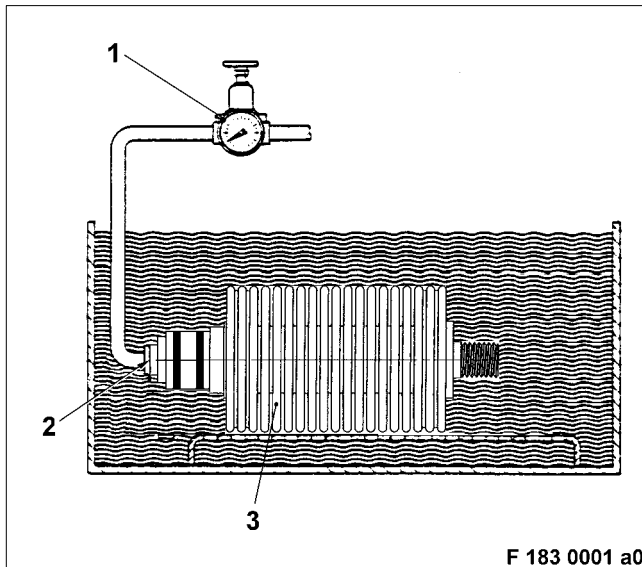

Seal oil chamber connections of cooler insert (3) with suitable sleeves, blank plugs, plugs with connection (2) and clamps.

At plug with connection, seal compressed air line.

WARNING

**Compressed air is air which has been compressed under pressure.
Test fluid is hot 80 °C (180°F).
Risk of injury!
Pressure must not exceed 0.5 bar (7.25 lb/in²).
Always wear protective clothing, protective gloves and protective goggles/safety mask.**

Soak cooler insert in test basin filled with water heated to 80 °C.

Open compressed air supply and set pressure reducer (1) to 0.5 bar.

Pressure-test intercooler for leaks with air in water bath; no bubbles should emerge.

If leaks are found, replace cooler insert.

After testing, remove compressed air line, sleeves and plugs.

CAUTION

**Compressed air is air which has been compressed under pressure. Risk of injury.
If compressed air is used for blowing out or blow-drying components, always wear protective goggles or safety mask.
Compressed air must not be directed at the body.
The pressure must not exceed 3.0 bar (40 lb/in²).**

Blow out cooling fins of cooler insert with compressed air in vertical direction.

C 183.05.11 Installation

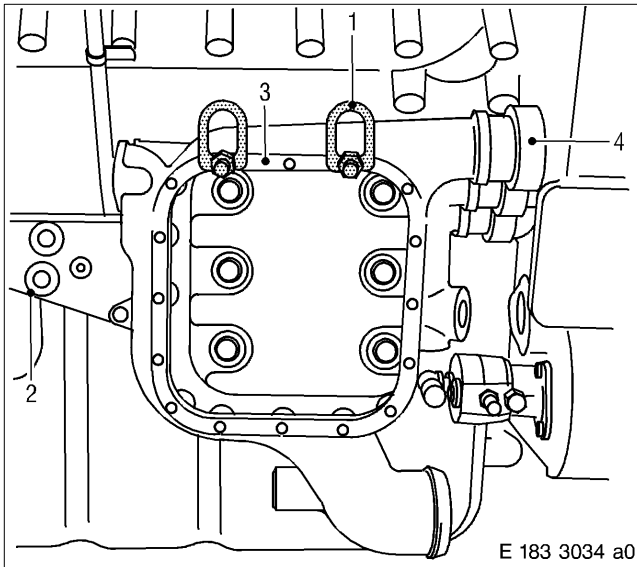

Installing oil heat exchanger

Note: Prior to installation, remove all blanking plug and/or covers.

Make sure that oil chambers and oilways are perfectly clean.

Prior to assembly, coat sealing rings and O-rings with petroleum jelly.

Mount bracket (2), housing (4) and plug-in pipes on crankcase as shown in General View – see C 183.05.01.

Install bypass valve, springs, blanking plugs and sealing ring into oil cooler housing as shown in General View – see C 183.05.01.

Prior to installation, coat sliding surfaces with engine oil and check bypass valve for ease of movement in bore of oil cooler housing.

WARNING

**Heavy object.
Risk of injury!
Use suitable tools and lifting equipment.**

Attach oil cooler housing to lifting eyes (1), rope and crane and mount with screws on retainer, paying special attention to fit of plug-in pipes.

Remove lifting eyes.

If necessary, remove blanking plug and/or covers in cooler insert.

Coat O-rings (1) with petroleum jelly and insert into grooves on cooler insert.

Note: Pay special attention to installation position marking (arrow) on cooler insert.

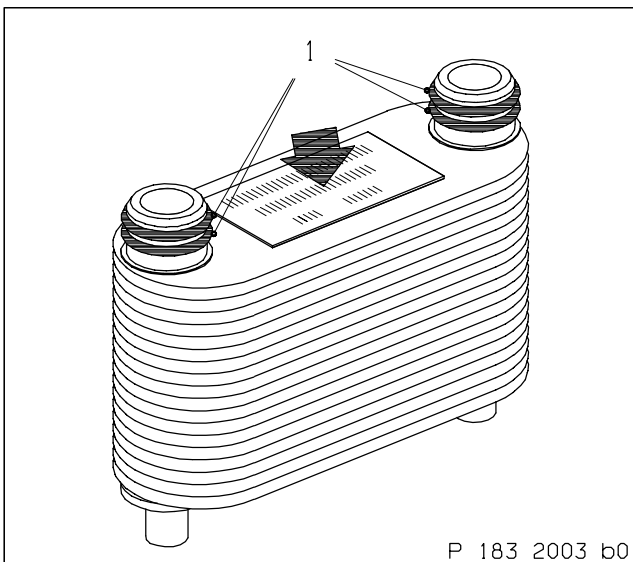

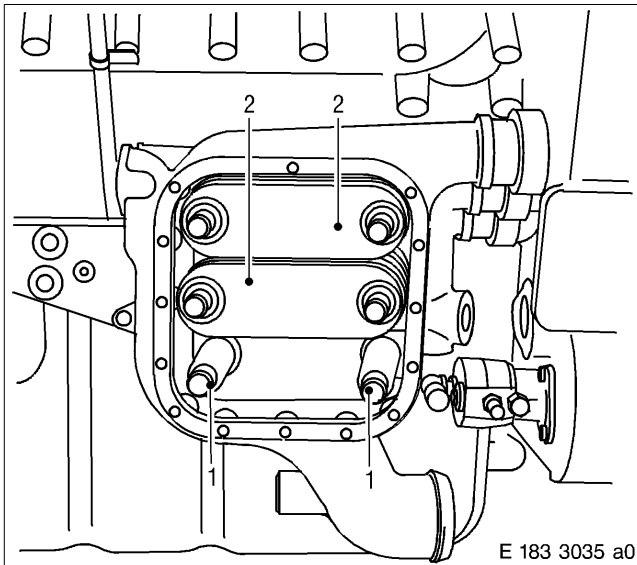

Insert cooler elements (2) into oil cooler housing in accordance with installation position marking.
Coat O-rings with petroleum jelly and insert into grooves on stud (1).
Insert stud into oil cooler housing.
Fit gaskets on stud and cooler inserts via thread – see General View.

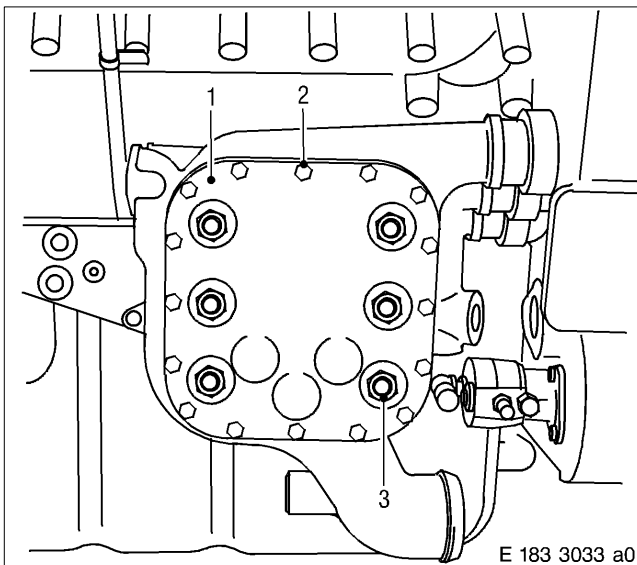

Install cover (1) with gasket and tighten screws (2) to specified tightening torque – see General View C 183.05.01.
Fit nuts (3) and tighten to specified tightening torque.

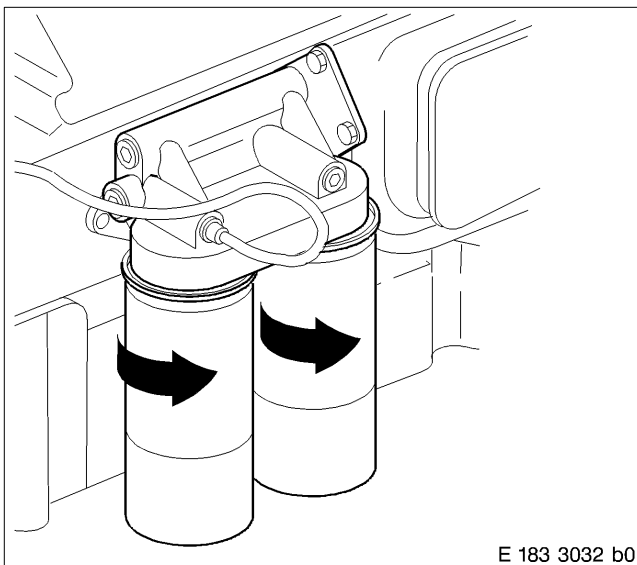

Installing oil filter

Note: Coat O-rings with petroleum jelly before installing.

Mount oil filter housing as shown in General View – see C 183.05.01.

Check sealing ring of new oil filter cartridges, clean as necessary and coat with oil.

Install new oil filter cartridges (arrows) and tighten manually.

Note: Do not use any tool to attach oil filter cartridges!

After test run, check oil filter for leaks; re-tighten as necessary.



C 183.05.12 After-Installation Operations

A distinction must be made as to whether:

- 1 — The engine was completely disassembled
- 2 — The engine is removed but was not disassembled
- 3 — The engine is installed

1	2	3	Operations	See
x	—	—	Perform operations as per Assembly Plan	B 005
x	—	—	Install engine	B 007
—	x	x	Connect coolant lines	C 202.15
—	x	x	Fill engine oil as necessary	—
—	—	x	Fill engine coolant system	Operating Instructions
—	—	x	Release engine start	Operating Instructions

C 184.10 Oil System in Crankcase

C 184.10.01 General View

Oil spray nozzle

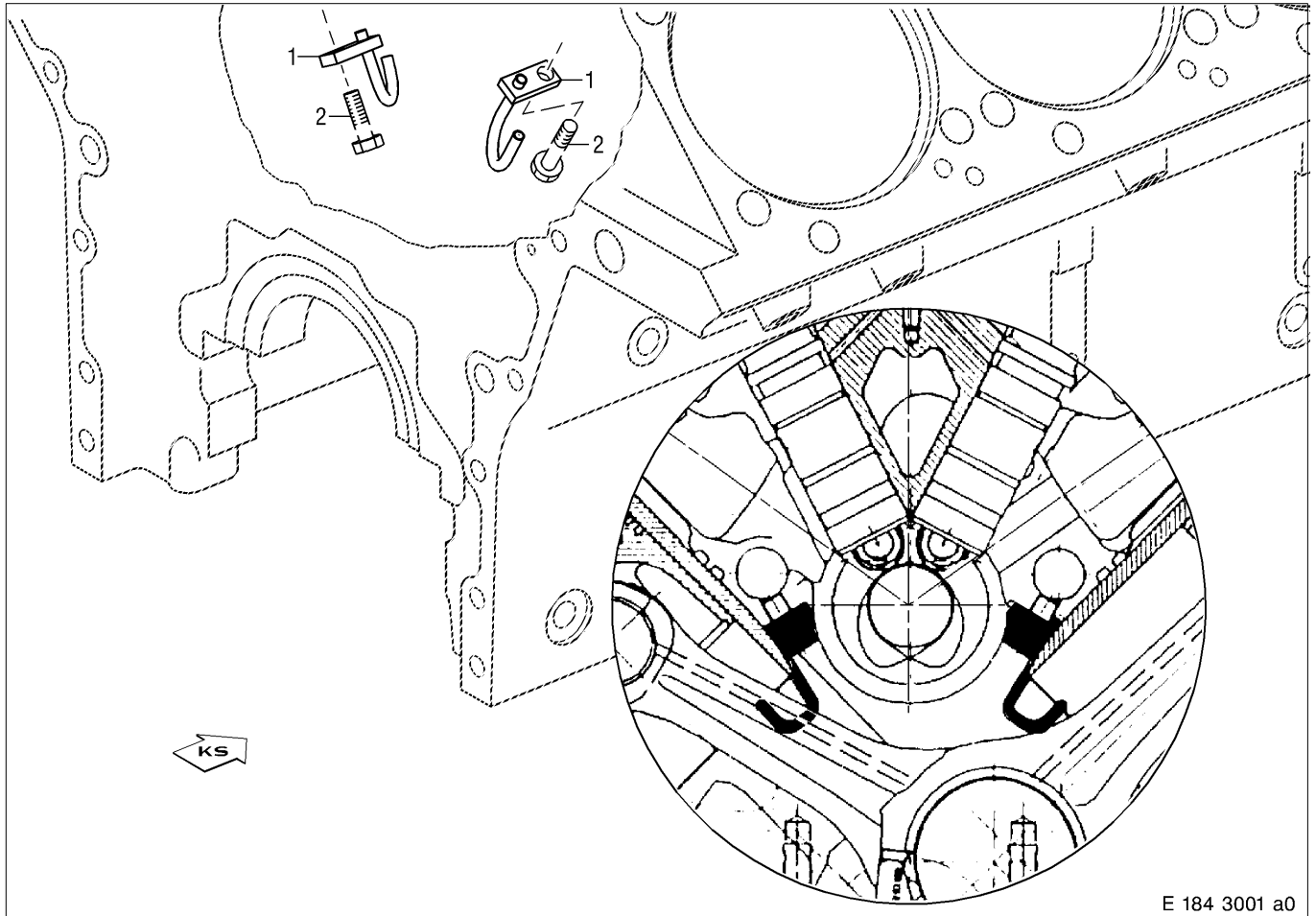

- 1 Oil spray nozzle
 - 2 Screw
- Tightening torque: 25 Nm
Lubricant: Engine oil

Oil supply to idler gears and crankshaft support bearings, free end

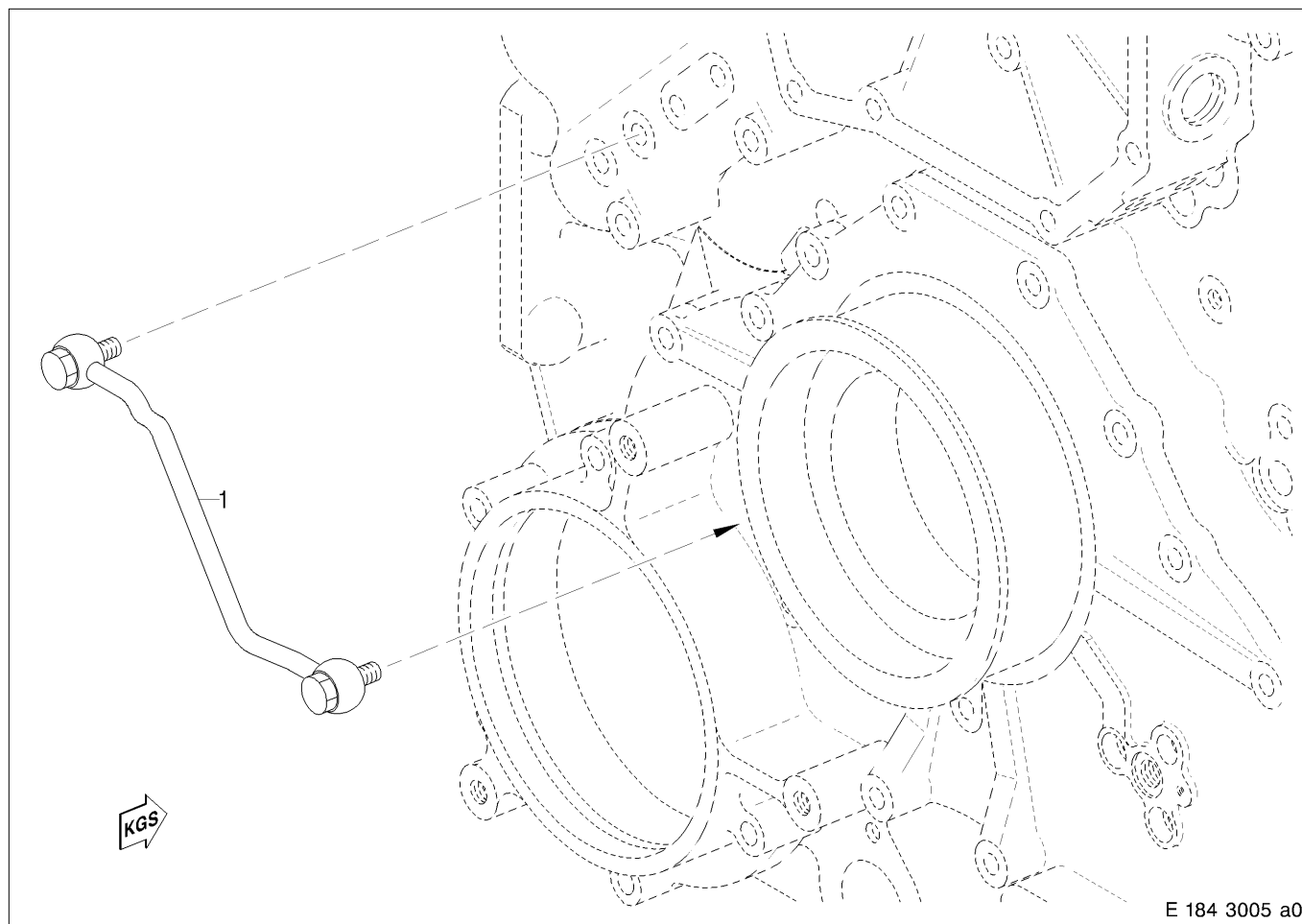

1 Pipe

C 184.10.02 Special Tool

Designation – Application	Number
Gauge for oil spray nozzle	1

C 184.10.04 Before-Removal Operations

A distinction must be made as to whether:

- 1 ————— The engine is to be completely disassembled
- 2 ————— The engine is to be removed but not disassembled
- 3 ————— The engine is to remain installed

1	2	3	Operations	See
x	-	-	Remove engine	B 003
x	-	-	Perform operations as per Disassembly Plan	B 004
-	-	x	Disable engine start	Operating Instructions
-	-	x	Drain or draw off engine oil*	Operating Instructions
-	x	x	Remove oil pan*	C 014.05

* – only when removing oil spray nozzle

C 184.10.05 Removal

Removing oil line

Remove oil line from engine as shown in General View – see C 184.10.01.

Remove sealing rings.

After removal, seal connections with suitable plugs.

Protect oil line from damage.

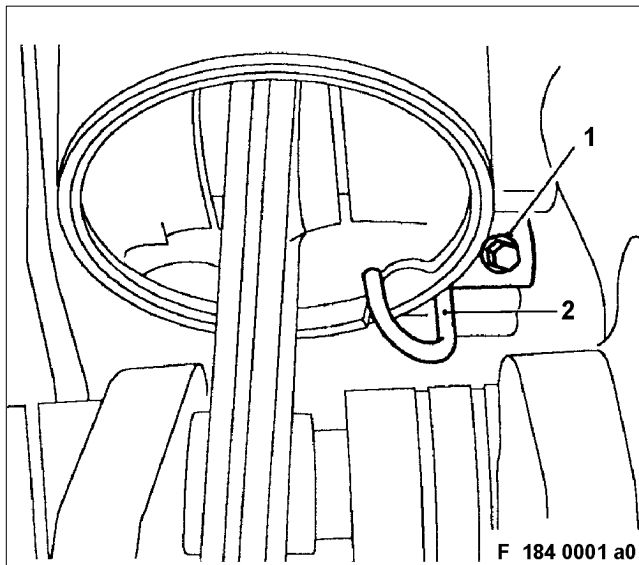

Removing piston cooling oil spray nozzle

Turn crankshaft until oil spray nozzle (2) to be removed is accessible.

Remove screw (1) and remove oil spray nozzle (2) from crankcase.

C 184.10.08 Inspection and Repair

Note: Make sure parts are perfectly clean.



CAUTION

Compressed air is air which has been compressed under pressure. If compressed air is used for blowing out or blow-drying components, always wear protective goggles or safety mask. Compressed air must not be directed at the body. The pressure must not exceed 3.0 bar (40 lb/in²).

Clean oil spray nozzle and oil line with "cleaner" and carefully blow clear with dry air.

Visually inspect component for damage and defects; replace if necessary.

Use red penetrant dye to surface crack-test oil spray nozzle. If cracks are found, replace oil spray nozzle.

Pressure-test oil line for leaks with air in water bath as necessary.



WARNING

Compressed air is air which has been compressed under pressure. Risk of injury. Pressure must not exceed 0.5 bar (7.25 lb/in²). Always wear protective clothing, protective gloves and protective goggles/safety mask.

Coolant temperature min. 30 °C (86 °F) – components must also be at this temperature; max. 40 °C, if component must be held in hands.

Test pressure: 0.5 bar

If leaks are found, replace oil line.

Then blow dry line with compressed air.

Check condition of threads; machine or replace components as necessary.

Check sealing and mating faces of oil spray nozzle; rub down with emery cloth or oilstone as necessary.

Check oil bores of oil spray nozzle (especially secondary bore 1 mm dia.) for obstructions and ensure they are perfectly clean!

Replace sealing rings as part of every disassembly.

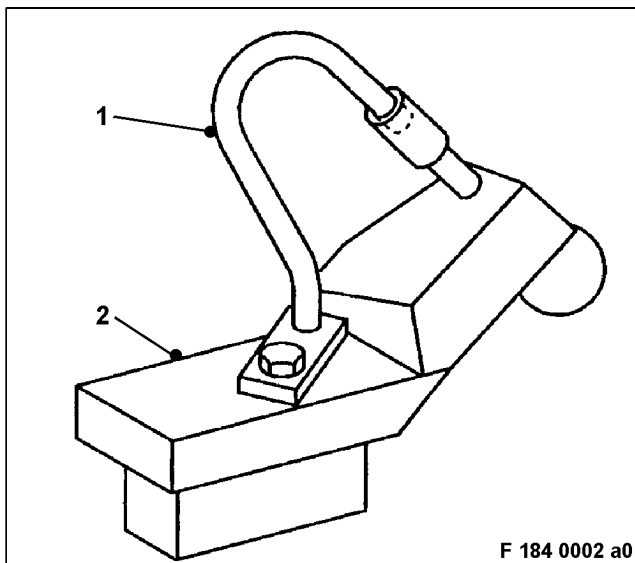

Checking spraying direction of oil spray nozzle

Attach oil spray nozzle (1) to gauge (2).

Use gauge to check oil injection pipe for plastic deformation.

In event of plastic deformation, correct oil spray pipe or replace oil spray nozzle.

F 184 0002 a0

C 184.10.11 Installation

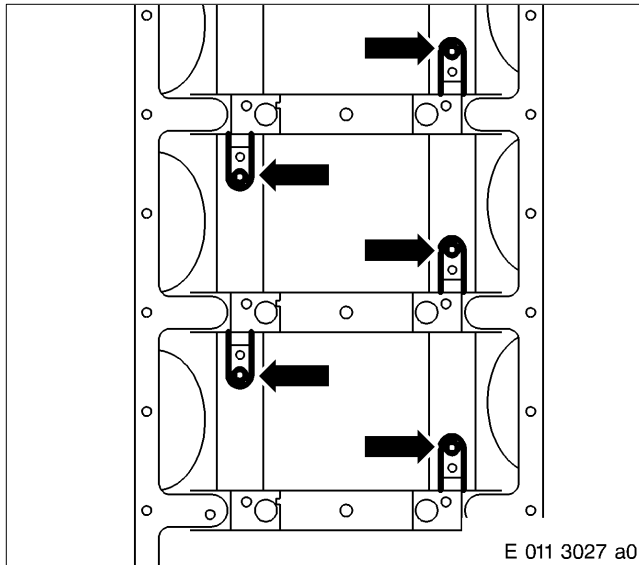

Installing piston cooling oil spray nozzle

Ensure oil bores (arrows) for oil spray nozzles in crankcase are perfectly clean and not obstructed.

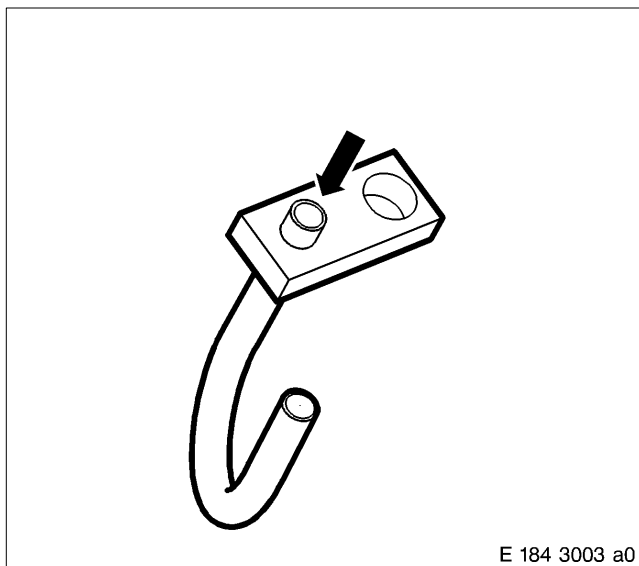

CAUTION

Compressed air is air which has been compressed under pressure. Risk of injury. If compressed air is used for blowing out or blow-drying components, always wear protective goggles or safety mask. Compressed air must not be directed at the body. The pressure must not exceed 3.0 bar (40 lb/in²).

Blow out oil bore (arrow) of oil spray nozzle with compressed air and ensure it is perfectly clean and not obstructed (especially secondary bore 1 mm dia.).

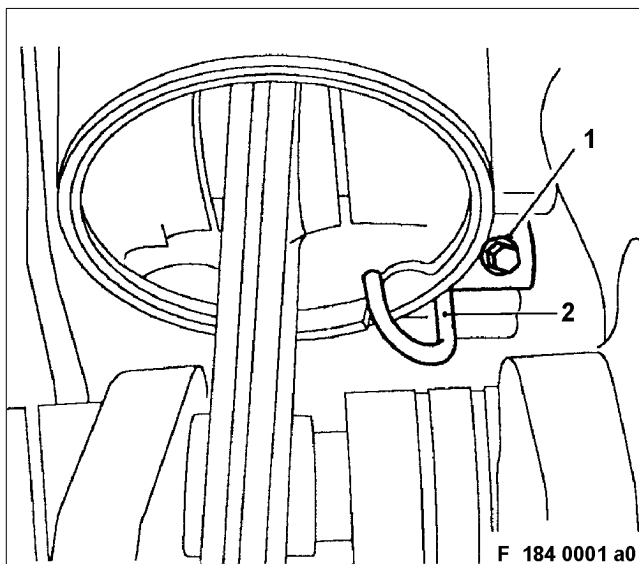

Fit oil spray nozzle (2) on crankcase; when doing so, guide on oil spray nozzle must engage in bore in crankcase.

Note: There are two securing screw lengths (16 mm and 20 mm) depending on crankcase version.

When using 20 mm screws, check that threaded bore is deep enough.

Tighten screw (1) to specified tightening torque – see C 184.01.01.

After installing piston, bar engine and ensure there is clearance between oil spray nozzle and piston.

Installing oil line

Note: Prior to installation, remove all blanking plugs.

CAUTION

Compressed air is air which has been compressed under pressure. If compressed air is used for blowing out or blow-drying components, always wear protective goggles or safety mask. Compressed air must not be directed at the body. The pressure must not exceed 3.0 bar (40 lb/in²).

Blow out oil line with compressed air and ensure that it is perfectly clean.

Mount oil line with new sealing rings free of tension as shown in General View – see C 185.10.01.

Note: After engine start, visually inspect oil line for leaks.

C 184.10.12 After-Installation Operations

A distinction must be made as to whether:

- 1 ————— The engine was completely disassembled
- 2 ————— The engine is removed but was not disassembled
- 3 — The engine is installed

1	2	3	Operations	See
x	–	–	Perform operations as per Assembly Plan	B 005
x	–	–	Install engine	B 007
–	x	x	Install oil pan	C 014.05
–	–	x	Fill oil system with engine oil	Operating Instructions
–	–	x	Release engine start	Operating Instructions

C 185.10 Oil Supply Lines for Exhaust Turbocharger

C 185.10.01 General View

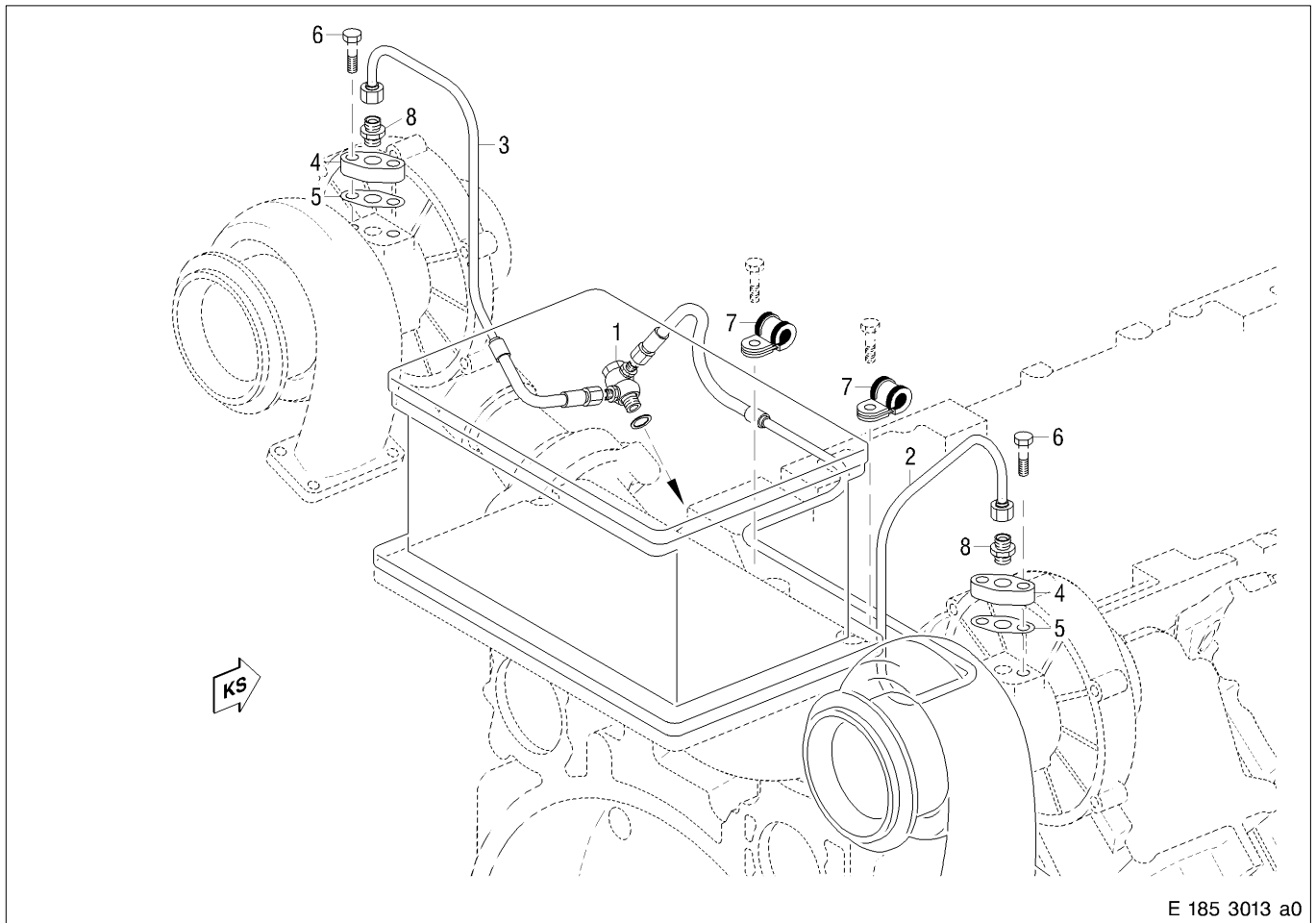

E 185 3013 a0

- | | |
|------------|-------------|
| 1 Union | 5 Gasket |
| 2 Oil line | 6 Screw |
| 3 Oil line | 7 Clamp |
| 4 Flange | 8 Connector |

C 185.10.04 Before-Removal Operations

A distinction must be made as to whether:

- 1 ————— The engine is to be completely disassembled
- 2 ————— The engine is to be removed but not disassembled
- 3 ————— The engine is to remain installed

1	2	3	Operations	See
x	-	-	Remove engine	B 003
x	-	-	Perform operations as per Disassembly Plan	B 004
-	-	x	Disable engine start	Operating Instructions

C 185.10.05 Removal

Removing oil supply lines

Remove oil lines, connection components and securing attachments from engine as shown in General View – see C 185.10.01.

Remove sealing rings and gaskets.

After removal, seal all connections with suitable plugs.

Protect oil lines from damage.

C 185.10.08 Inspection and Repair

Note: Make sure parts are perfectly clean.

Clean oil lines with cleaner. Check condition of lines and inspect for damage; replace lines if necessary.

Pressure-test oil lines for leaks with air in water bath as necessary.



WARNING

Compressed air is air which has been compressed under pressure. Risk of injury. Pressure must not exceed 0.5 bar (7.25 lb/in²). Always wear protective clothing, protective gloves and protective goggles/safety mask.

Coolant temperature min. 30 °C – components must also be at this temperature; max. 40 °C, if component must be held in hands.

Test pressure: 0.5 bar

If leaks are found, replace oil line.



CAUTION

Compressed air is air which has been compressed under pressure. If compressed air is used for blowing out or blow-drying components, always wear protective goggles or safety mask. Compressed air must not be directed at the body. The pressure must not exceed 3.0 bar (40 lb/in²).

Then blow dry lines with compressed air.

Check connecting components and fixtures of oil lines for damage and wear; replace components as necessary.

Check sealing and mating faces, smooth with oilstone or emery cloth if necessary.

Check condition of threads; machine or replace components as necessary.

Replace sealing rings and gaskets.

C 185.10.11 Installation

Installing oil supply lines

Note: Prior to installation, remove all blanking plugs.



CAUTION

Compressed air is air which has been compressed under pressure. If compressed air is used for blowing out or blow-drying components, always wear protective goggles or safety mask. Compressed air must not be directed at the body. The pressure must not exceed 3.0 bar (40 lb/in²).

Blow out oil lines with compressed air and ensure that it is perfectly clean.

Install oil lines with new sealing rings, gaskets with connecting components and fixtures as shown in General View – see C 185.10.01 – making sure lines are free from tension.

Note: After engine start, visually inspect oil lines for leaks.



C 185.10.12 After-Installation Operations

A distinction must be made as to whether:

- 1 — The engine was completely disassembled
- 2 — The engine is removed but was not disassembled
- 3 — The engine is installed

1	2	3	Operations	See
x	-	-	Perform operations as per Assembly Plan	B 005
x	-	-	Install engine	B 007
-	-	x	Release engine start	Operating Instructions



C 185.25 Oil Return Lines for Exhaust Turbocharger

C 185.25.01 General View

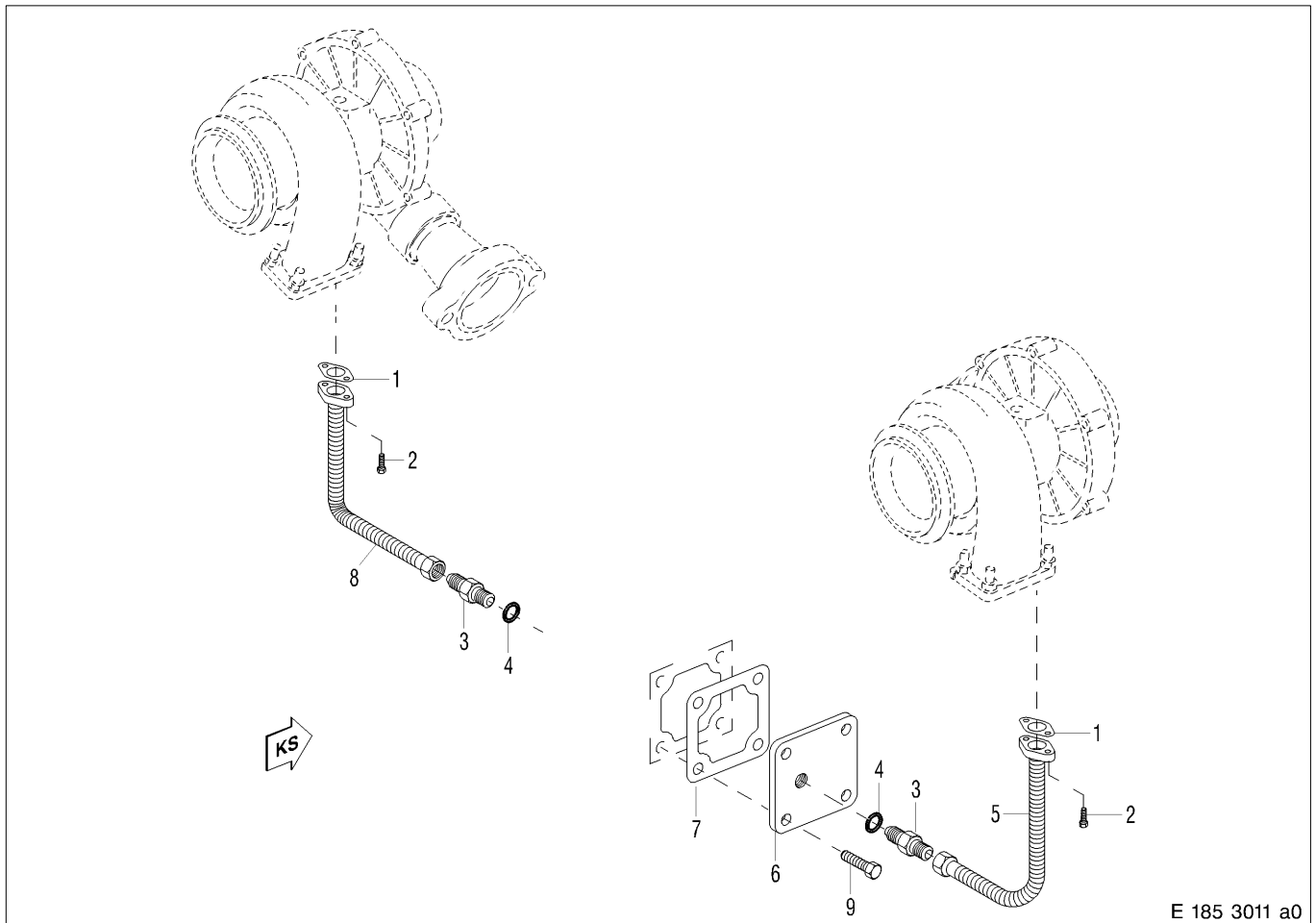

- | | |
|----------------|------------|
| 1 Gasket | 6 Cover |
| 2 Screw | 7 Gasket |
| 3 Union | 8 Oil line |
| 4 Sealing ring | 9 Screw |
| 5 Oil line | |

C 185.25.04 Before-Removal Operations

A distinction must be made as to whether:

- | | | |
|---|-------|--|
| 1 | _____ | The engine is to be completely disassembled |
| 2 | _____ | The engine is to be removed but not disassembled |
| 3 | _____ | The engine is to remain installed |

1	2	3	Operations	See
x	-	-	Remove engine	B 003
x	-	-	Perform operations as per Disassembly Plan	B 004
-	-	x	Disable engine start	Operating Instructions

C 185.25.05 Removal

Removing oil return lines

Remove oil lines, connection components and securing attachments from engine as shown in General View – see C 185.25.01.

Remove gaskets, sealing rings and gaskets.

After removal, seal all connections with suitable plugs.

C 185.25.08 Inspection and Repair

Note: Make sure parts are perfectly clean.

Clean oil lines with cleaner. Check condition of lines and inspect for damage; replace lines if necessary.

Pressure-test oil lines for leaks with air in water bath as necessary.



WARNING

Compressed air is air which has been compressed under pressure. Risk of injury. Pressure must not exceed 0.5 bar (7.25 lb/in²). Always wear protective clothing, protective gloves and protective goggles/safety mask.

Coolant temperature min. 30 °C – components must also be at this temperature; max. 40 °C, if component must be held in hands.

Test pressure: 0.5 bar

If leaks are found, replace oil line.

Check connecting components and fixtures of oil lines for damage and wear; replace components as necessary.

Check sealing and mating faces, smooth with oilstone or emery cloth if necessary.

Replace gaskets, sealing rings and gaskets.

C 185.25.11 Installation

Mounting oil return lines

Note: Prior to installation, remove all blanking plugs.



CAUTION

Compressed air is air which has been compressed under pressure. If compressed air is used for blowing out or blow-drying components, always wear protective goggles or safety mask. Compressed air must not be directed at the body. The pressure must not exceed 3.0 bar (40 lb/in²).

Blow out oil lines with compressed air and ensure that it is perfectly clean.

Install oil lines with new gaskets, sealing rings and gaskets free of tension as shown in General View – see C 185.25.01.

Note: After engine start, visually inspect oil lines for leaks.



C 185.25.12 After-Installation Operations

A distinction must be made as to whether:

- 1 — The engine was completely disassembled
- 2 — The engine is removed but was not disassembled
- 3 — The engine is installed

1	2	3	Operations	See
x	-	-	Perform operations as per Assembly Plan	B 005
x	-	-	Install engine	B 007
-	-	x	Release engine start	Operating Instructions



Contents

C 200 Cooling System

C 200.08 Pressure testing coolant chamber

C 202.05 Engine coolant pump

C 202.05.01 General view

C 202.05.02 Special tool

C 202.05.04 Before-removal operations

C 202.05.05 Removal

C 202.05.06 Disassembly

C 202.05.08 Inspection and repair

C 202.05.10 Assembly

C 202.05.11 Installation

C 202.05.12 After-installation operations

C 202.10 Engine coolant lines

C 202.10.01 General view

C 202.10.04 Before-removal operations

C 202.10.05 Removal

C 202.10.08 Inspection and repair

C 202.10.11 Installation

C 202.10.12 After-installation operations

C 206.05 Coolant distribution housing and thermostat

C 206.05.01 General view

C 206.05.02 Special tool

C 206.05.04 Before-removal operations

C 206.05.05 Removal

C 206.05.08 Inspection and repair

C 206.05.11 Installation

C 206.05.12 After-installation operations

C 200 Cooling System

(TC version)

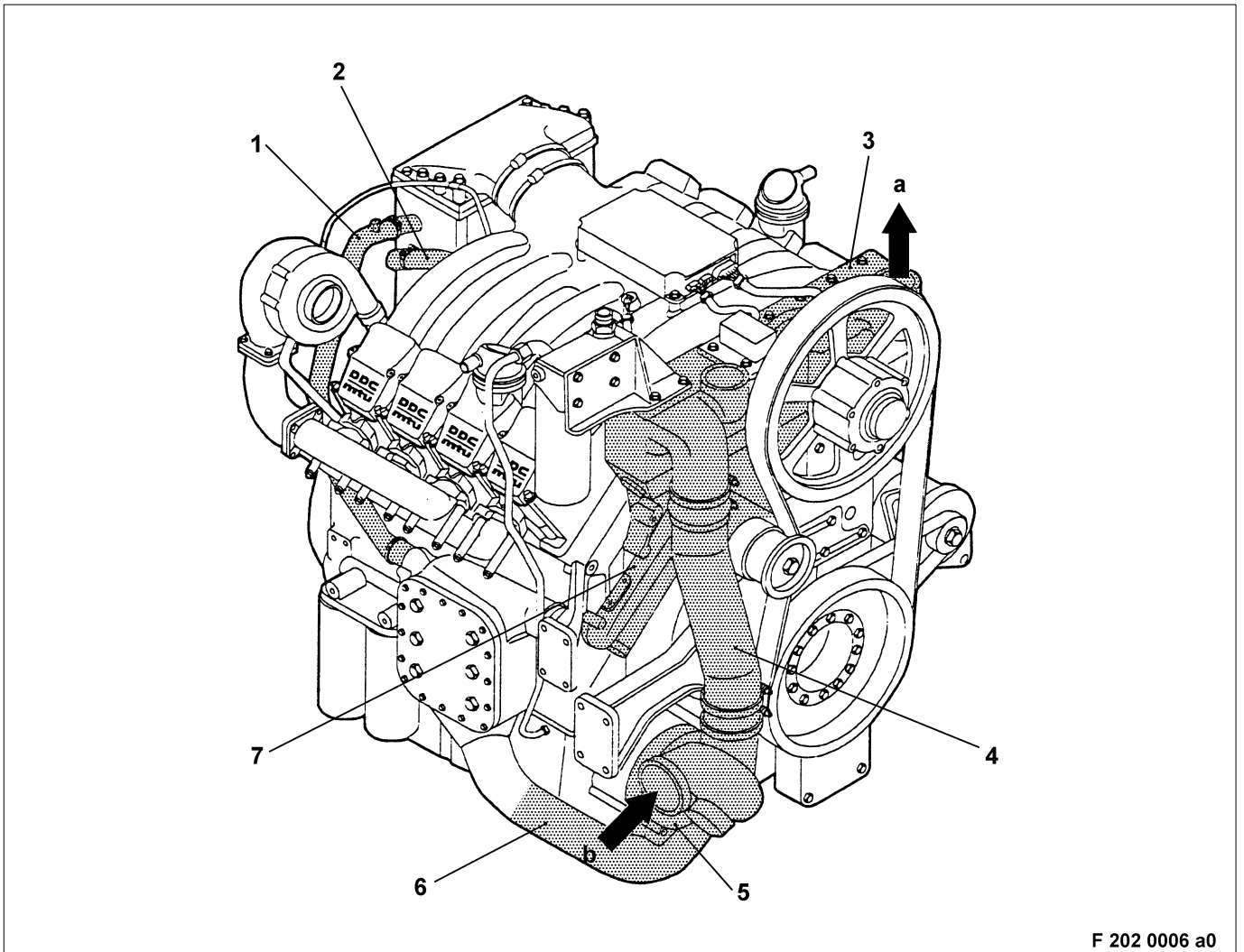

F 202 0006 a0

- 1 Engine coolant line
- 2 Engine coolant line
- 3 Thermostat housing
- 4 Engine coolant line

- 5 Engine coolant pump
- 6 Engine coolant line
- 7 Coolant distribution housing

a to cooler

b from cooler

The following is a list of auxiliary equipment and materials needed for the assembly operations:

CAUTION
<p>When using these chemical substances, it is essential to observe the Manufacturer's Instructions for use, safety instructions and waste disposal specifications.</p>

Materials and consumables	Designation	Order No.		Remarks
		MTU	DDC	
Emery cloth				
Magnifying glass				
Inspection lamp				
Vaseline	Petroleum jelly, white	40317		
Surface sealant	Loctite No. 573	40031		Final strength ≈ 48 h
Special lubricating paste	International Compound No. 2		DDC 7Y2	
Thread-locking agent, high-strength	Loctite No. 290		9S-250	Final strength at 20 °C ≈ 12 h
Engine oil				
Cleaning agent	Solvclean KW	40022		
Decalcifying agent	Porodox or Euron 1308			
Corrosion preventive	Pfinder AP 11 F	40355		
Denaturated ethanol		40250		
Thin-film lubricant	Molycote g-N plus	40041		
Multipurpose grease	Shell Retinax A	40333		
Kerosene or diesel fuel				
Sealing paste	Elastosil N 189	50545		
Engineer's blue	blue	40641		
Antifriction bearing grease	Texando F020	50107		
Corrosion preventive	Caramba Express	40008		
Dry compressed air				
Surface crack-testing equipment with red penetrant dye				



C 200.08 Pressure-Testing Coolant Chambers

Note: After assembling engine, pressure-test coolant jackets with compressed air and check for leaks.



WARNING

**Only use hydraulic pressure testing device specified by Manufacturer.
Observe specified safety and accident prevention regulations!**

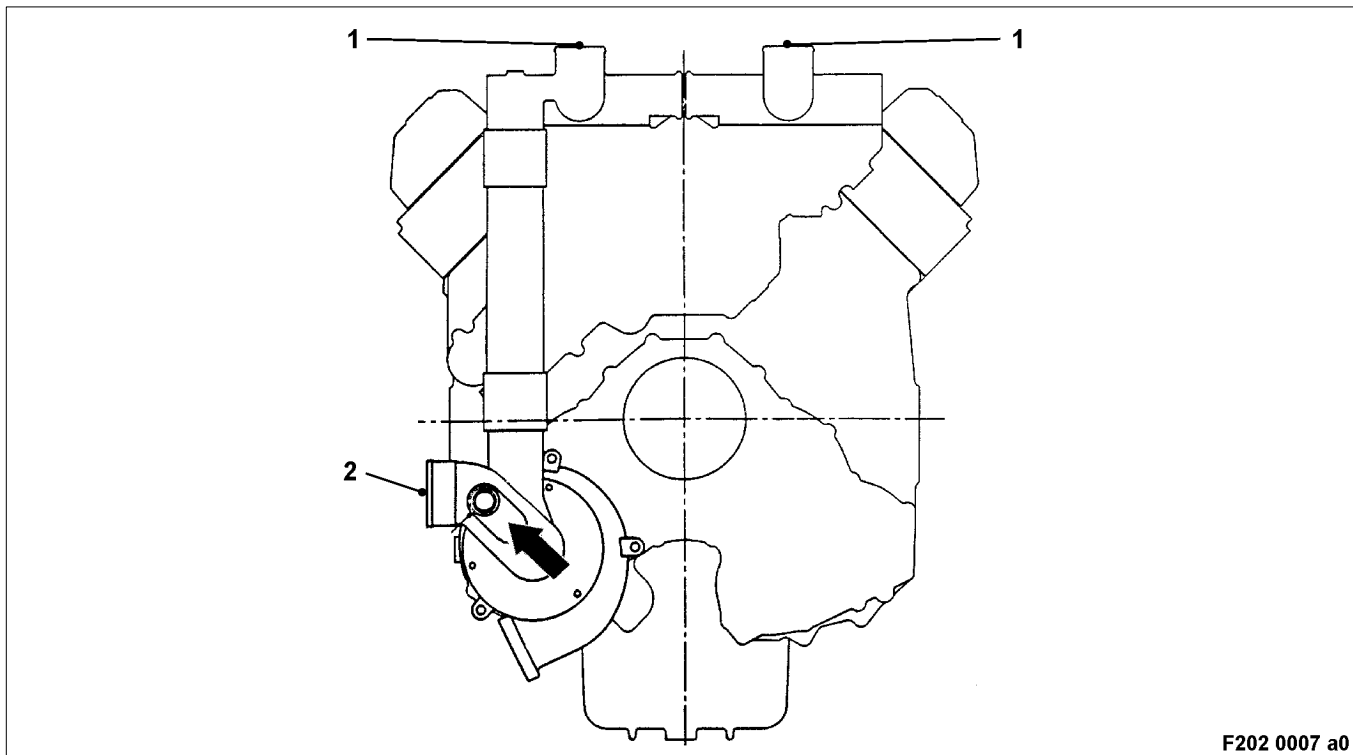

F202 0007 a0

Seal openings in thermostat housing (1) and in inlet adapter (2) with press-off end covers.
Connect compressed air supply line of hydraulic pressure testing device to inlet adapter (arrow).



WARNING

Compressed air is air which has been compressed under pressure. Risk of injury. Test pressure must not be exceeded. Always wear protective clothing, protective gloves and protective goggles/safety mask.

Pressure-test engine coolant chambers with compressed air and test for leaks.

Filling pressure = 1.38 bar (20 psi)

Filling time = 120 s

Max. leak rate = 250 cm³/min

Measuring time = 35 s

If the max. leak rate is exceeded, determine cause and rectify.

C 202.05 Engine Coolant Pump

C 202.05.01 General View

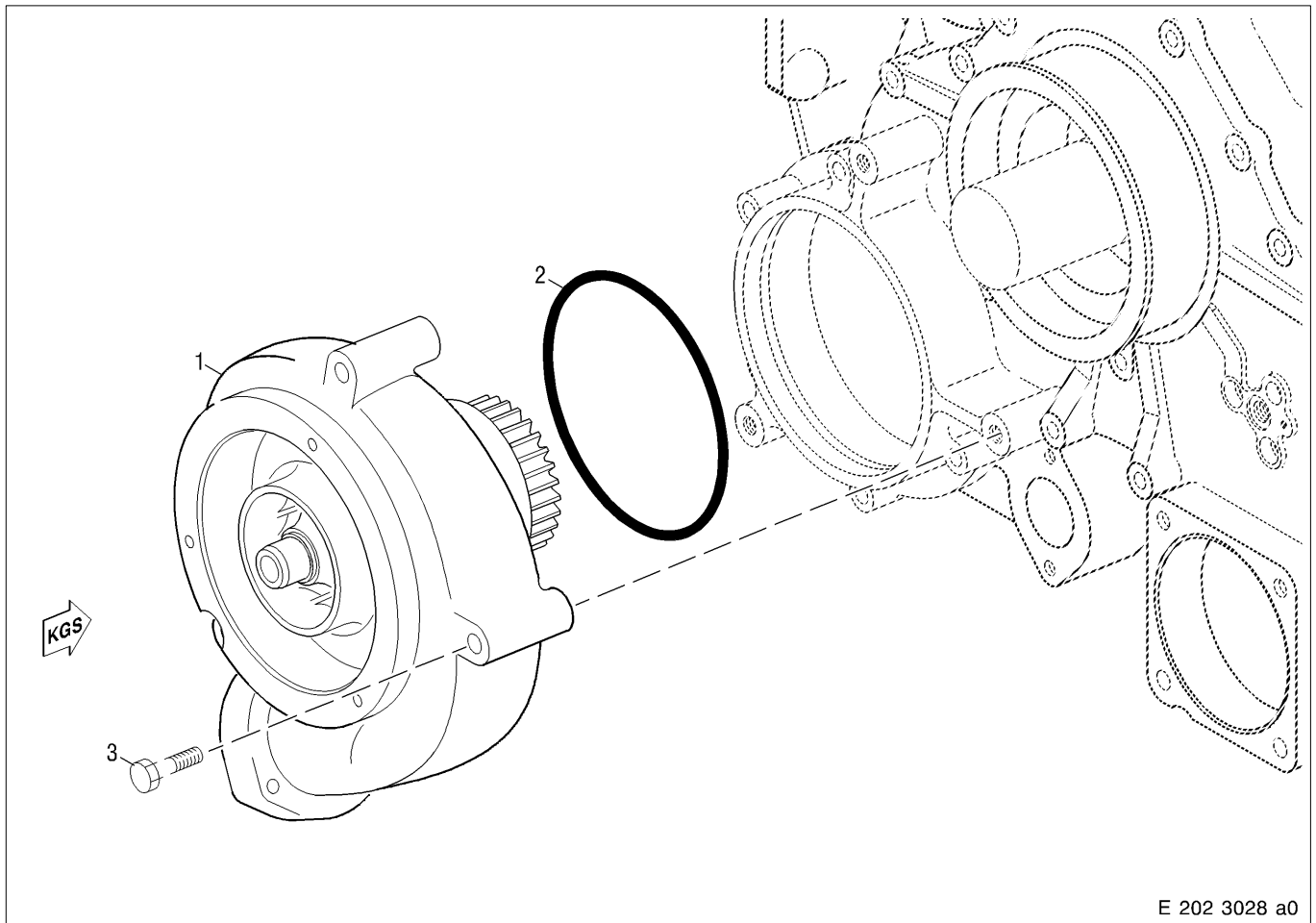

- 1 Coolant pump
- 2 O-ring
- 3 Screw

Engine coolant pump

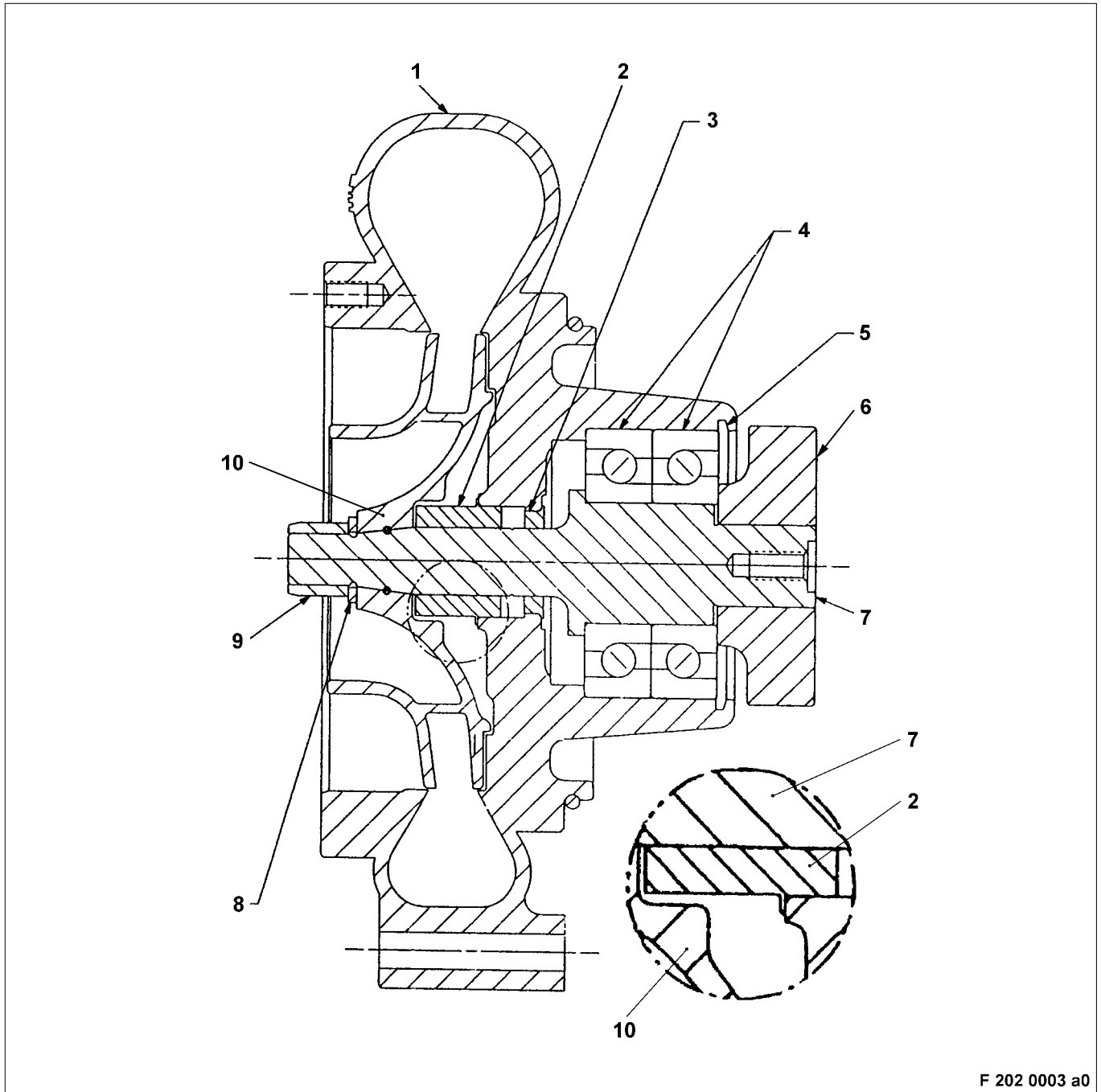

F 202 0003 a0

- | | |
|----------------|--|
| 1 Housing | 8 Washer |
| 2 Gasket | 9 Nut |
| 3 Axial gasket | Tightening torque: 300 Nm + 25 Nm |
| 4 Bearing | Lubricant: Special lubricating paste DDC 7Y2 |
| 5 Circlip | Secure seat of impeller: |
| 6 Drive gear | Checking torque: 340 Nm |
| 7 Shaft | 10 Impeller |

C 202.05.02 Special Tool

Designation – Application	Number
Retaining device for coolant pump	1
Removal tool for impeller	1
Removal tool for gear	1
Press-in sleeve for ball bearing	1
Press-in mandrel for radial-lip shaft seal	1
Press-in sleeve for shaft	1
Press-in sleeve for rotary seal	1
Testing unit for secure seat of impeller	1

C 202.05.04 Before-Removal Operations

A distinction must be made as to whether:

- 1 ————— The engine is to be completely disassembled
- 2 ————— The engine is to be removed but not disassembled
- 3 ————— The engine is to remain installed

1	2	3	Operations	See
x	–	–	Remove engine	B 003
x	–	–	Perform operations as per Disassembly Plan	B 004
–	–	x	Disable engine start	Operating Instructions
–	–	x	Drain engine coolant	Operating Instructions
	x	x	Disconnect engine coolant lines	C 202.10
	x	x	Remove fuel pump	C 081.05

C 202.05.05 Removal

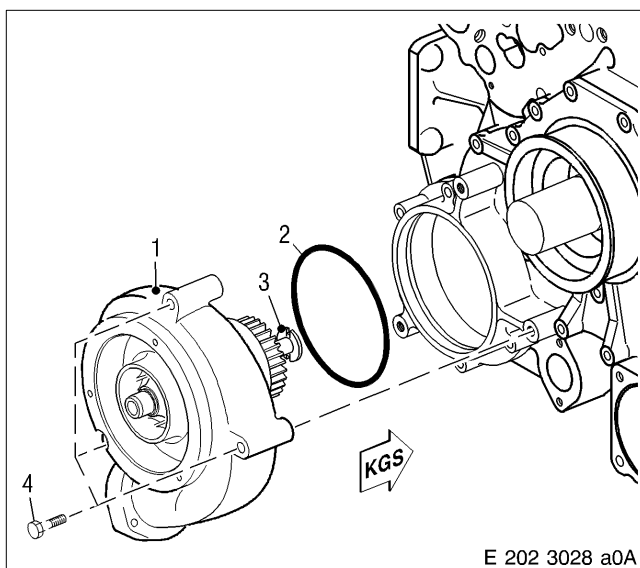

Removing coolant pump

Remove securing screws (4) for engine coolant pump (1).

Release engine coolant pump with lifting iron from gear case cover and remove.

If necessary, cover installation bore of engine coolant pump.

Remove O-ring (2) from engine coolant pump.

If necessary, remove driver (3) for fuel pump mounted on front of coolant pump shaft – also see C 081.05.

C 202.05.06 Disassembly

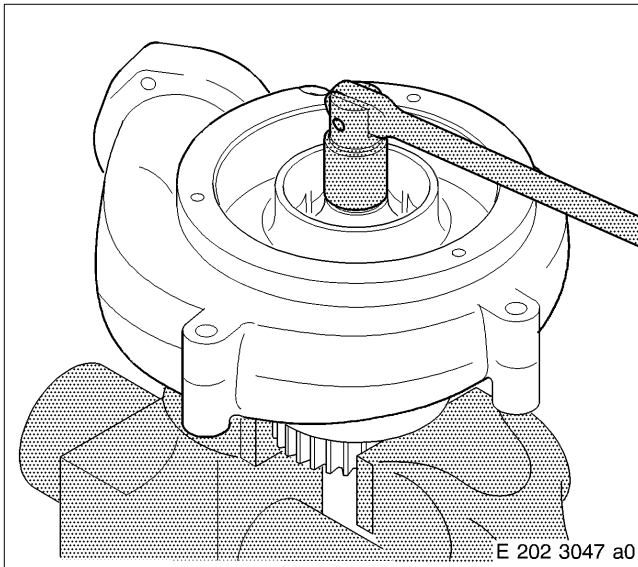

Disassembling coolant pump

Secure coolant pump in retainer or vice with aluminum jaws on gear.

Remove nut and washer for impeller.

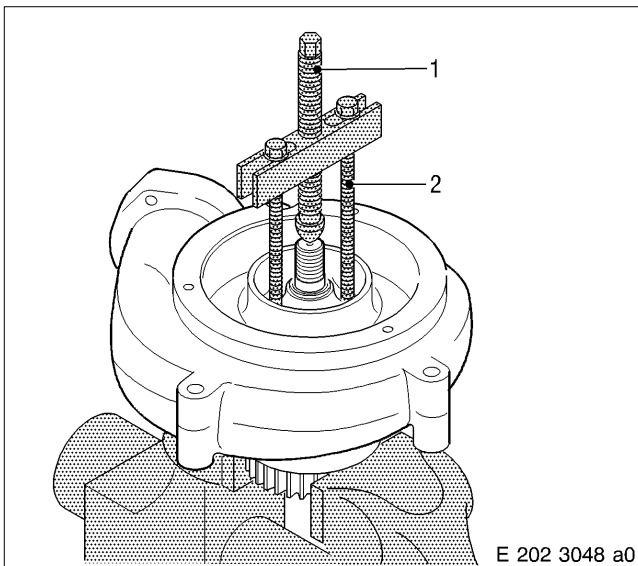

Install removal tool by inserting both screws (2) into impeller.

Turn jackscrew (1) to remove impeller from shaft.

Remove removal tool and impeller.

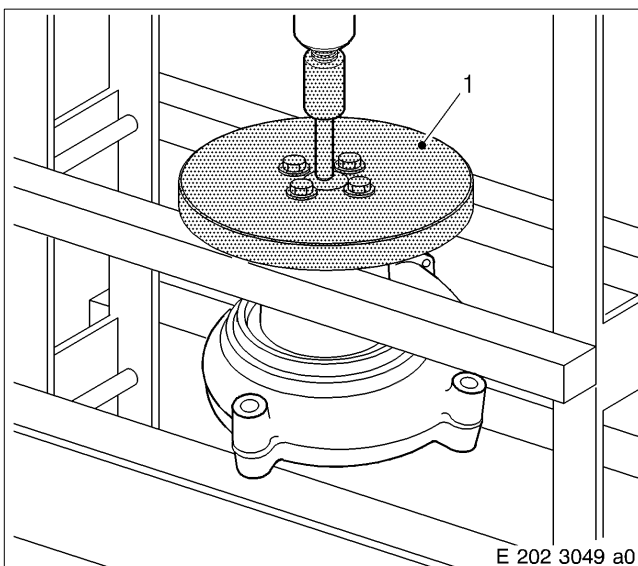

Mount removal tool (1) on gear.

Using hydraulic press, press gear off shaft.

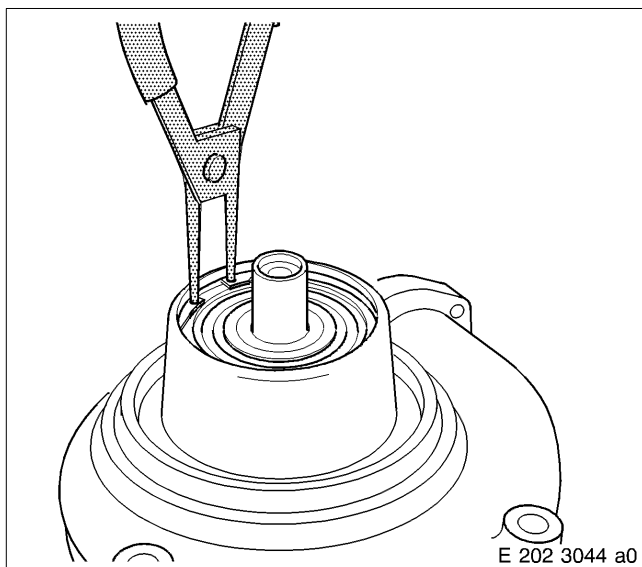

⚠ CAUTION

**Snap ring pretension.
Risk of injury.
Use suitable circlip pliers. Always wear protective goggles/safety mask.**

Remove snap ring with circlip pliers from coolant pump housing.

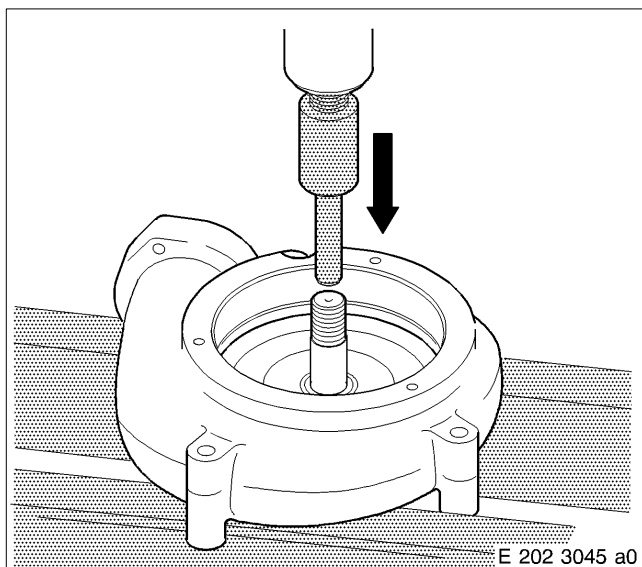

Using manual press, press shaft and bearing out of coolant pump housing (arrow).

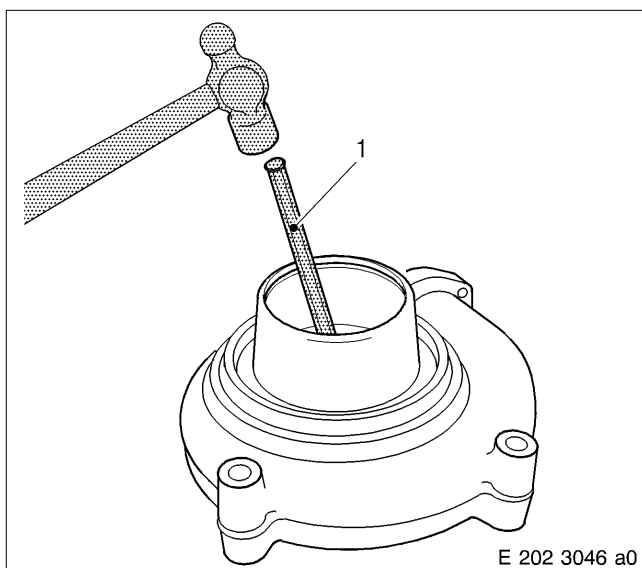

Using brass mandrel (1) and hammer, drive radial-lip shaft seal and rotary seal out of coolant pump housing; hammer evenly around the entire circumference.

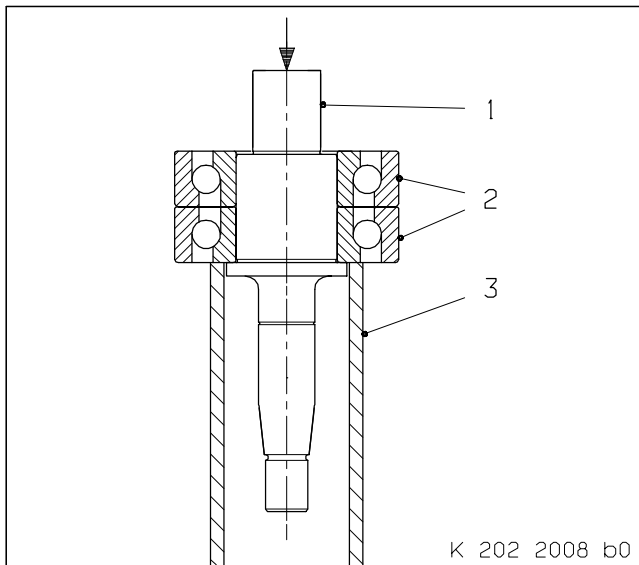

Note: When reusing bearings, take extra special care during removal operations. Only apply removal pressure to ball bearing inner rings, not to rolling elements!
Bearing inner race and bearing outer race are seen as a single unit and must not be interchanged.

Using manual press, press shaft (1) out of bearings (2) (arrow); for this purpose, support at ball bearing inner ring with a suitable sleeve (3).

C 202.05.08 Inspection and Repair

Clean all components, visually inspect for damage, wear and cracks.



WARNING

Fuels and fuel vapours are flammable and poisonous. Risk of fire, explosions and poisoning! When using fuel: – do not use naked flame – no electric sparks – do not smoke – do not spill fuel Do not inhale. Always wear protective gloves and protective goggles/safety mask. Ventilate working area well.

Use petroleum spirit or acid-free kerosene to clean the antifriction bearings.

After cleaning, relubricate the bearings with engine oil.

In event of damage, wear or cracks, replace the respective component.

Visually inspect sealing surfaces on coolant pump housing, impeller and inlet adapter for wear, pitting and cavitation; rub down with emery cloth or an oilstone or replace component.

Check coolant pump housing and impeller for cavitation. In event of pitting, replace component.

Check shaft for wear. Smooth out slight wear with a polishing cloth or replace shaft.

Check gear for indentations and wear; rub down with an oilstone and emery cloth or replace gear as necessary.

Check condition of threads; rechase threads if necessary.

Adjust bore gauge and measure bearing bores in coolant pump housing.

Using micrometer measure bearing seat on shaft.

If limit values are exceeded (see Tolerances and Wear Limits List) replace components.

Replace bearing as part of every W6 overhaul.

Replace O-ring, radial-lip oil seal, slip-ring seal and nut as part of every disassembly.

C 202.05.10 Assembly

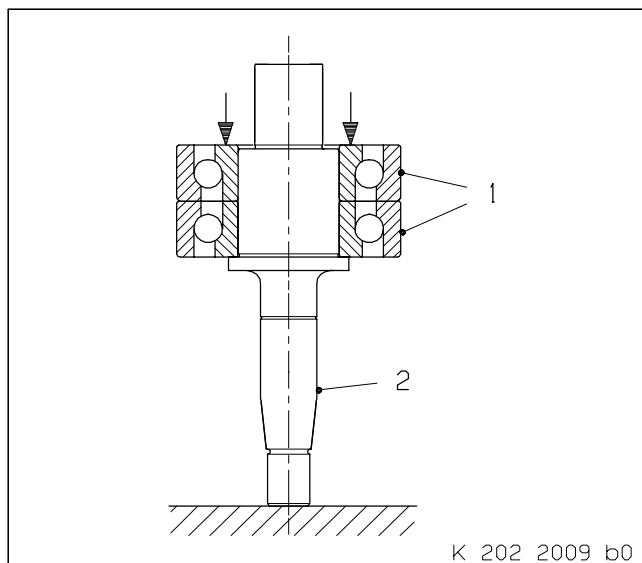

Assembling coolant pump

Note: Make sure that oil-retaining parts are perfectly clean.
Bearing inner race and bearing outer race are seen as a single unit and must not be interchanged.

Using manual press and press-in sleeve, press lubricated bearing (1) onto shaft (2), positioning correctly, in accordance with illustration; for this purpose, apply installation pressure to bearing inner races (arrows).

Note: Position of bearing must be as shown in illustration!

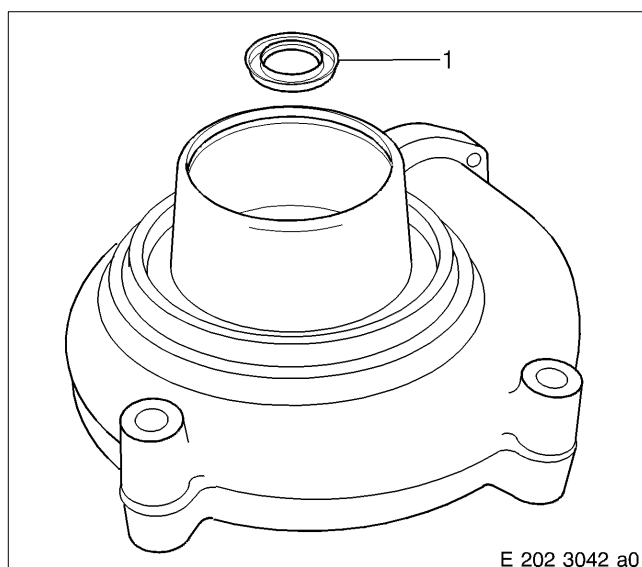

Coat seating faces of radial lip shaft seal (1) and in housing with engine oil.

Using manual press and press-in mandrel, fit press radial-lip shaft seal (with sealing lip facing press-in mandrel) into coolant pump housing.

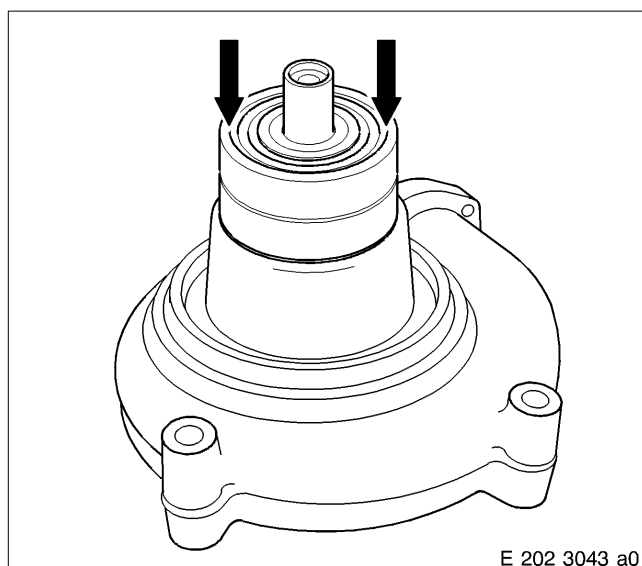

Coat sealing lip of radial-lip shaft seal with petroleum jelly and coat running surface of radial lip shaft seal on shaft with thin-film lubricant.

Insert shaft and bearing into coolant pump housing; ensure that sealing lip of radial-lip shaft seal is not damaged.

Using manual press and press-in sleeve, insert shaft and bearing into coolant pump housing.

Note: Only apply installation pressure to bearing outer race (arrows)! Never exceed press-on pressure of 450 kp.

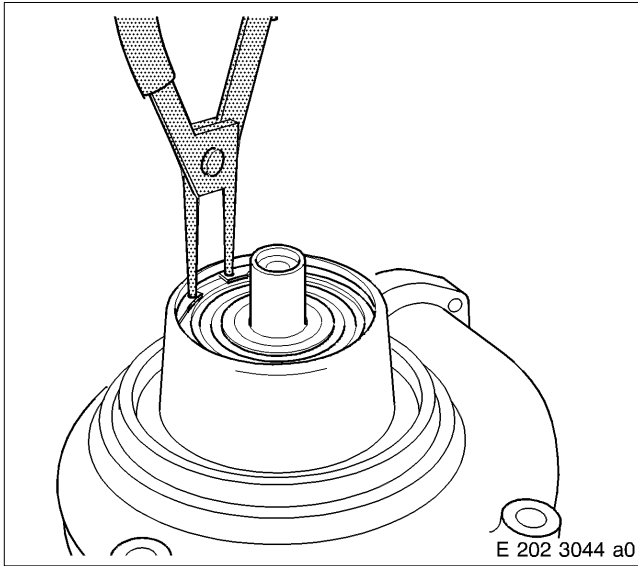

! CAUTION

**Snap ring pretension.
Risk of injury.
Use suitable circlip pliers. Always wear protective goggles/safety mask.**

Secure bearing in coolant pump housing with snap ring.

Note: Basil on snap ring faces outwards. Make sure that snap ring is correctly seated.

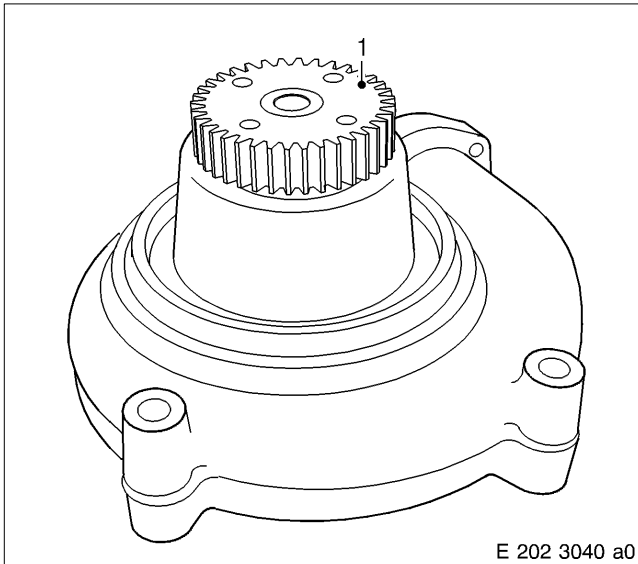

Using manual press, press drive gear (1) onto bearing inner race on shaft until it contacts the stop.

Note: Only support on shaft, not on coolant pump housing!

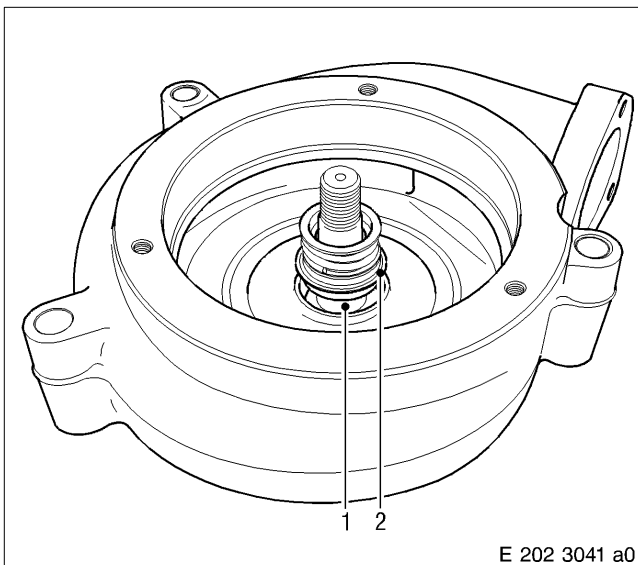

Dry-clean and degrease bore of rotary seal (2) and mating face on shaft (1) and coat with high-strength thread-locking agent.

Fit rotary seal on shaft as shown in illustration.

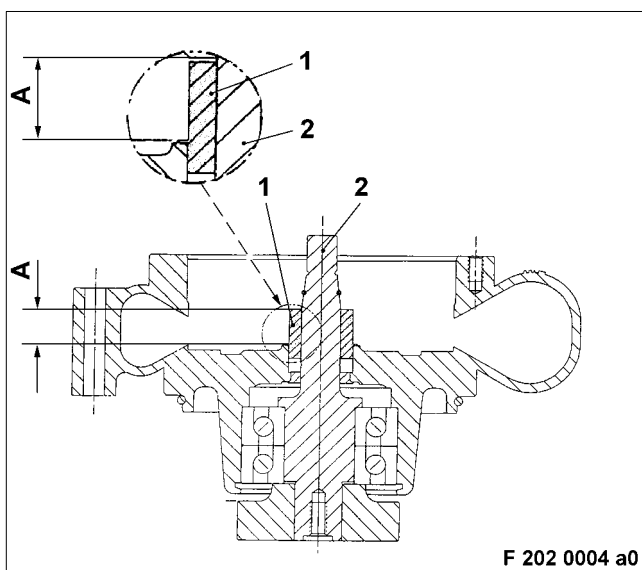

Note: Never apply installation pressure to bearings!
Support at shaft and at coolant pump housing!

Insert rotary seal (1) with manual press and press-in sleeve into coolant pump housing until contact is made.

Check projection A.

A = from 22.61 mm to 23.11 mm

Note: Dimension A must be maintained to ensure that rotary seal seals correctly.

Apply a drop of high-strength thread-locking agent to contact line between rotary seal and shaft. Thread-locking agent is distributed in rings in the joint; wipe off excess thread-locking agent.

Note: In order to obtain final strength of high-strength thread-locking agent, place coolant pump in vertical position for approx. 15 – 30 min. and do not turn coolant pump shaft during this period.

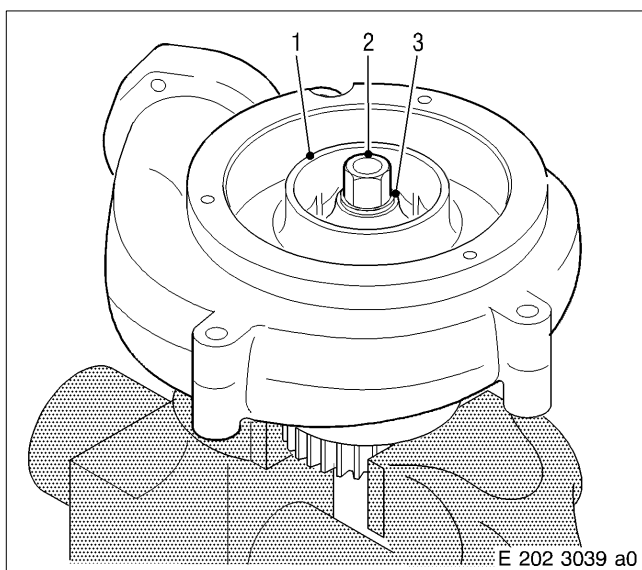

Hold coolant pump in retaining device or in vice with aluminium jaws on gear.

Clean taper on shaft and impeller.

Mount impeller (1) on shaft.

Coat thread of shaft with special lubricating paste DDC 7Y2 .

Fit washer (3), screw on new nut (2) and tighten to specified tightening torque – see C 202.05.01.

Hold gear in place in retainer or in vice.

Note: When tightening, neither drive gear nor impeller should turn!

Secure testing unit for secure seat of impeller in threads in impeller.

Using torque wrench, check secure seat of impeller on shaft with check torque – see C 202.05.01.

It must not be possible to turn impeller or gear; if it is possible, remove impeller and determine cause.

Remove testing unit and remove coolant pump from retaining device or vice.

Turn pump shaft to check for ease of movement; impeller must turn without obstruction.

C 202.05.11 Installation

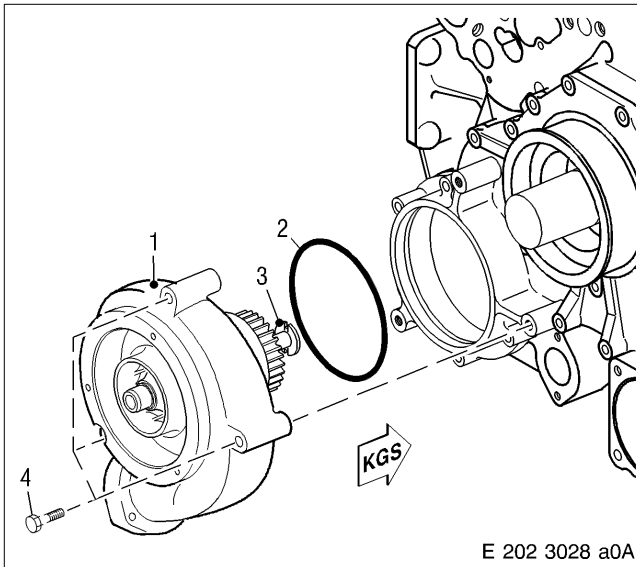

Installing coolant pump

Note: Prior to installation, remove cover.

Install driver (3) for fuel pump on front of pump shaft and tighten to specified tightening torque – see C 081.05.

Coat O-ring (2) with petroleum jelly on coolant pump housing.

Check sealing surface fit in gear case cover and clean as necessary.

Positioning correctly, insert engine coolant pump (1) into bore in gear case cover, ensuring that gear engages.

Insert securing screws (4) and tighten evenly.

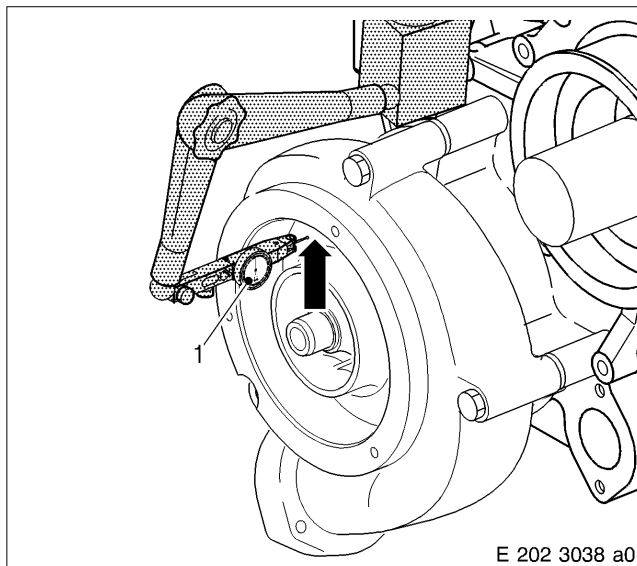

Measuring tooth backlash

Note: Measure backlash on impeller as it cannot be measured on drive gear (inaccessible).

Attach magnetic-base indicator holder with Puppi dial gauge unit (1) on gear case cover.

Insert screw into impeller (arrow).

Fit Puppi dial gauge unit on screw.

Set dial gauge to zero.

Block idler gear.

Move coolant pump drive gear back and forth to check backlash.

Read dial gauge and make a note of backlash.

For backlash, see C 020.

If max. backlash is exceeded, remove coolant pump and determine cause.

Remove screw from impeller!



C 202.05.12 After-Installation Operations

A distinction must be made as to whether:

- 1 — The engine was completely disassembled
- 2 — The engine is removed but was not disassembled
- 3 — The engine is installed

1	2	3	Operations	See
x	—	—	Perform operations as per Assembly Plan	B 005
x	—	—	Install engine	B 007
—	x	x	Install fuel pump	C 081.05
—	x	x	Connect engine coolant lines	C 202.10
—	—	x	Fill engine coolant system	Operating Instructions
—	—	x	Release engine start	Operating Instructions



C 202.10 Engine Coolant Lines

C 202.10.01 General View

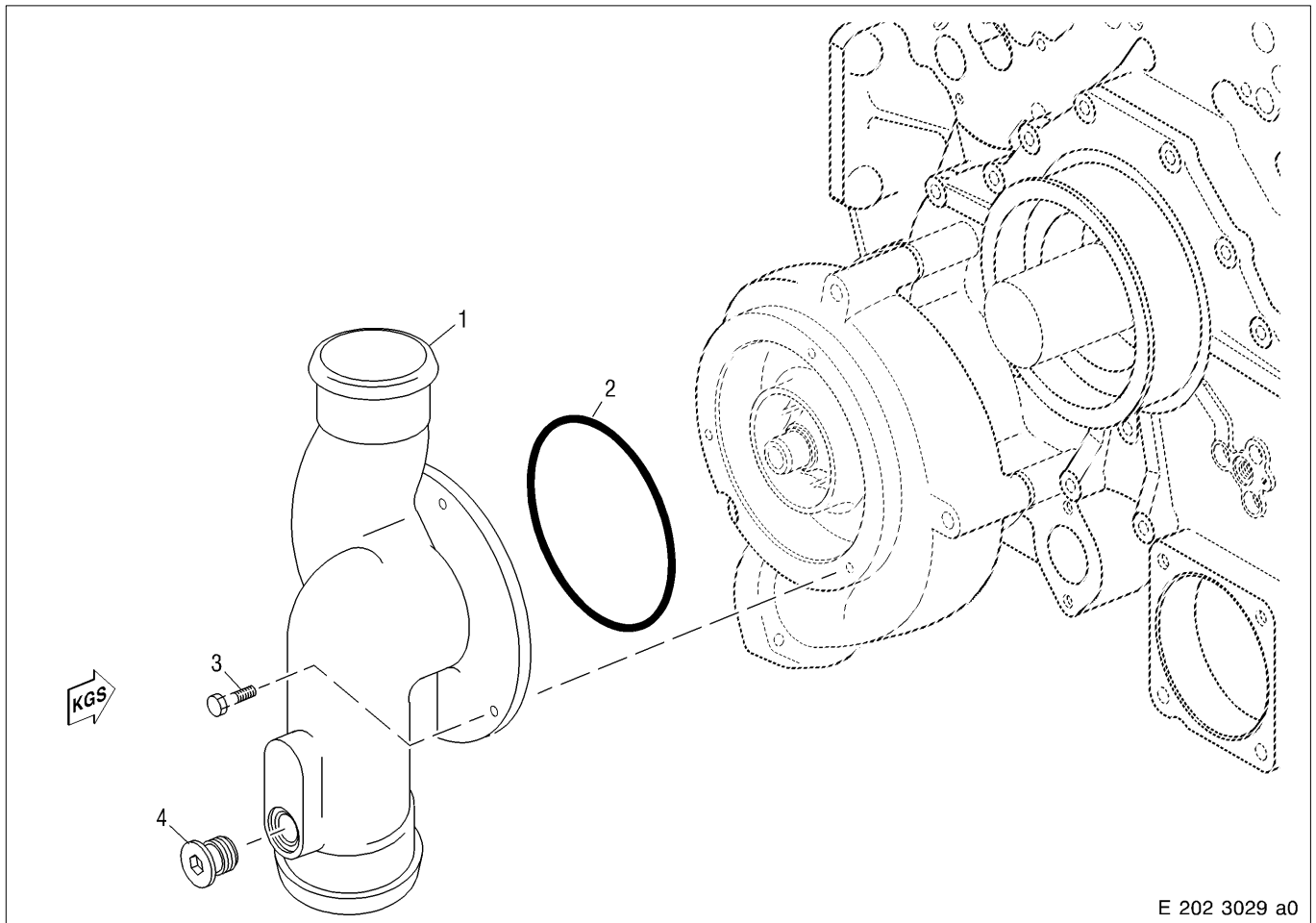

E 202 3029 a0

- 1 Inlet adapter
- 2 O-ring
- 3 Screw
- 4 Plug

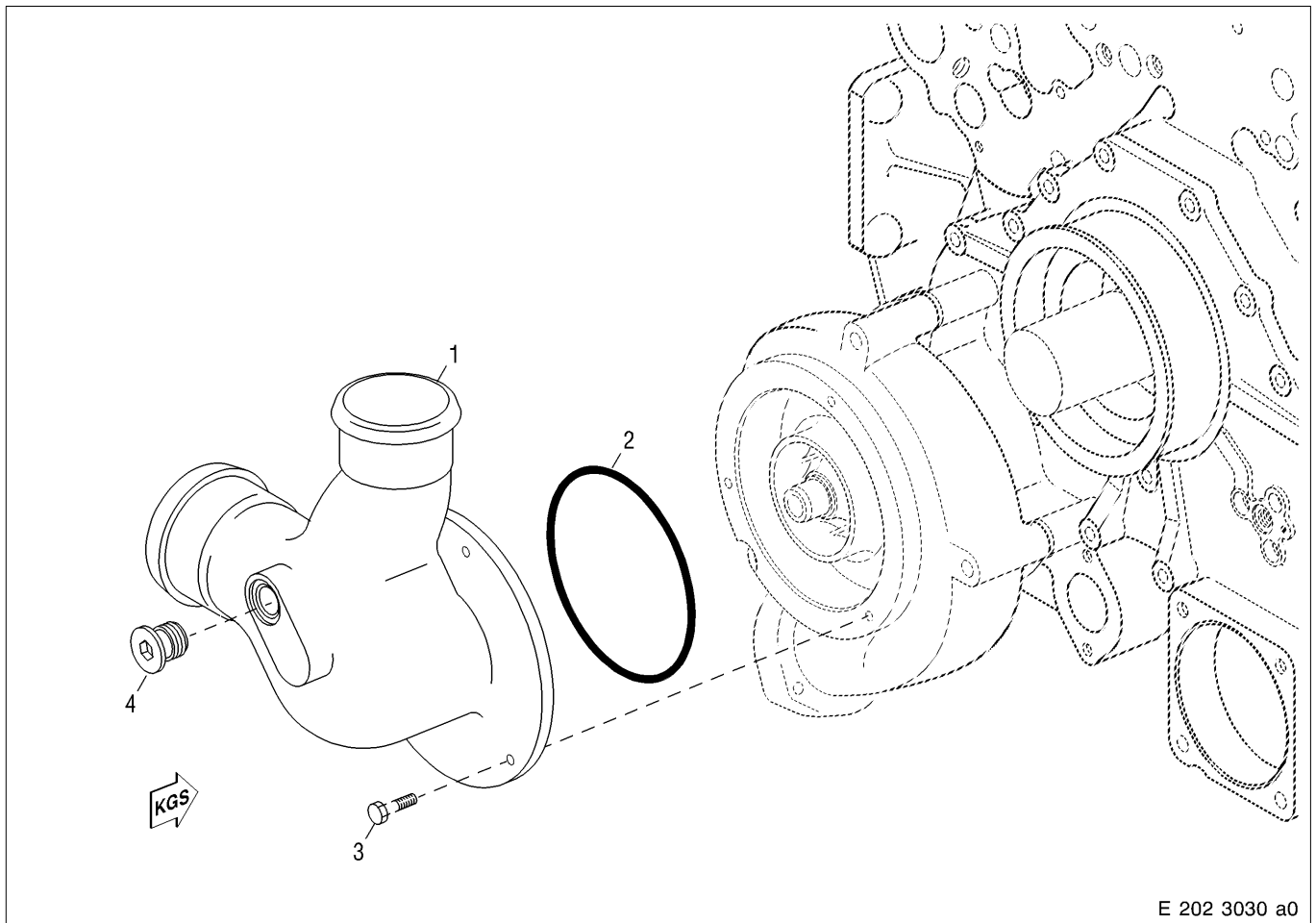

- 1 Inlet adapter
- 2 O-ring
- 3 Screw
- 4 Plug

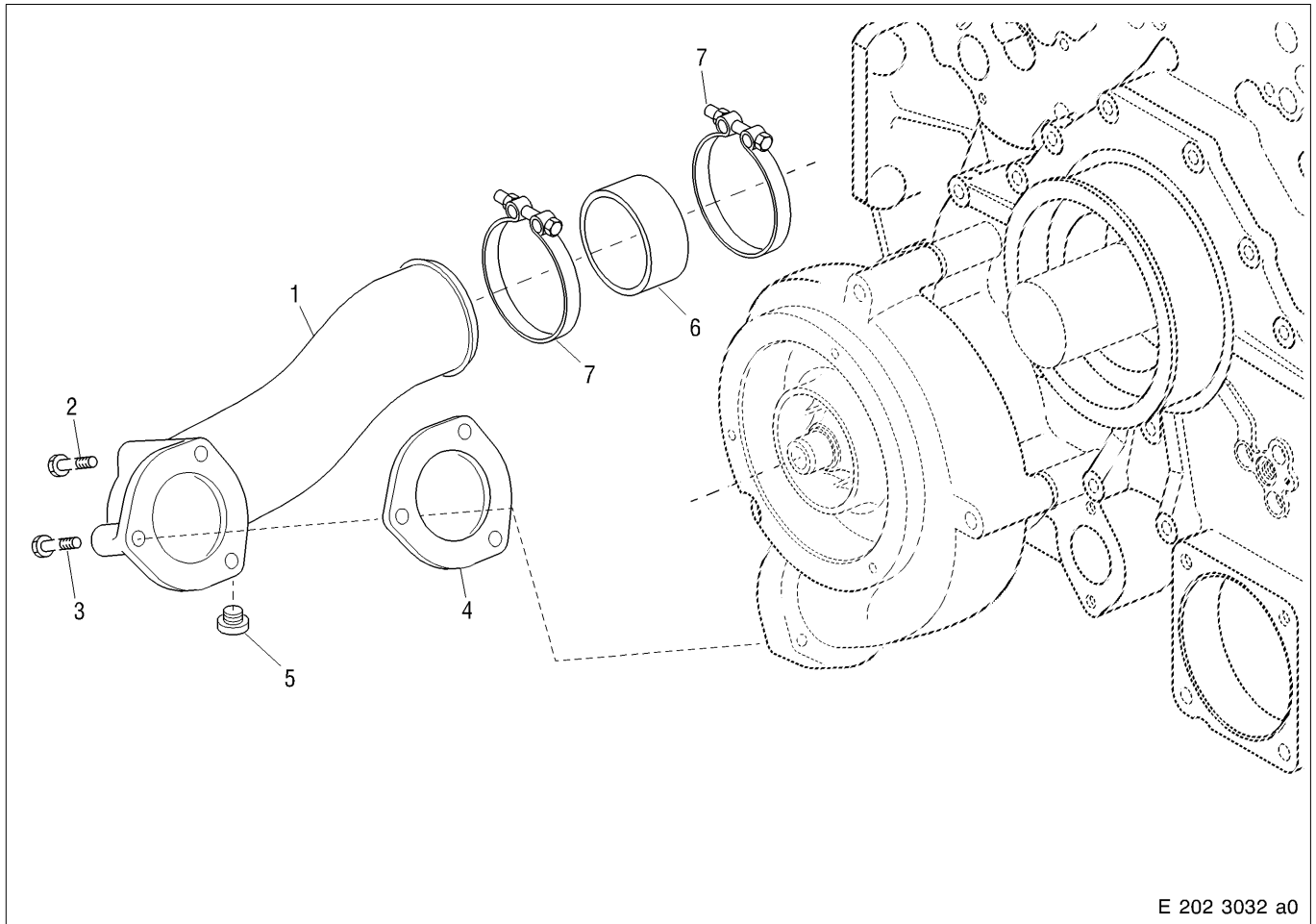

- 1 Outlet connection
- 2 Screw
- 3 Screw
- 4 Gasket

- 5 Plug
- 6 Hose line
- 7 Hose clamp

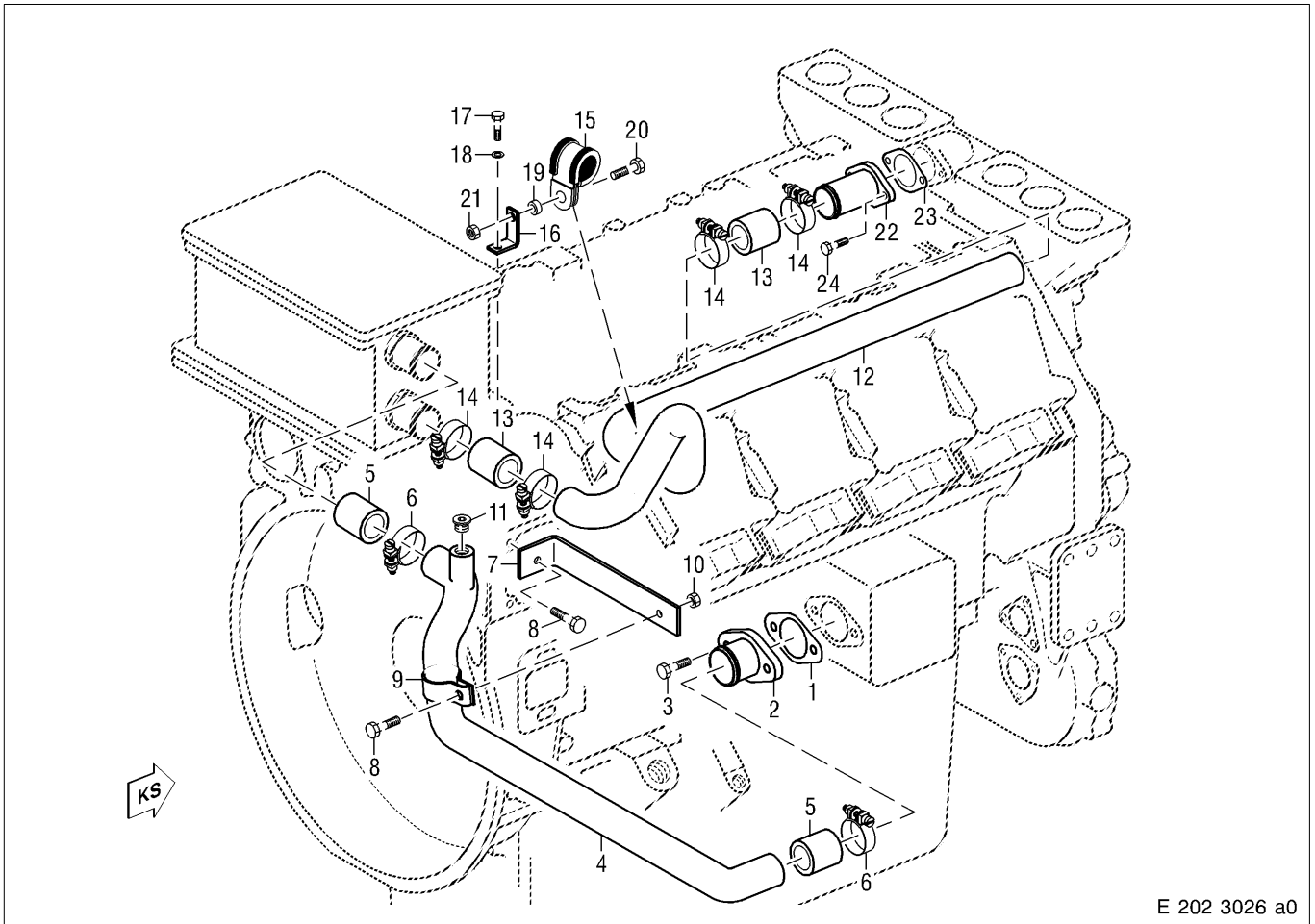

E 202 3026 a0

- | | |
|-----------------|------------------|
| 1 Gasket | 13 Hose line |
| 2 Flange | 14 Clamp |
| 3 Screw | 15 Clamp |
| 4 Pipe | 16 Bracket |
| 5 Hose line | 17 Hex screw |
| 6 Clamp | 18 Washer |
| 7 Bracket | 19 Spacer |
| 8 Screw | 20 Screw |
| 9 Clamp | 21 Nut |
| 10 Nut | 22 Inlet adapter |
| 11 Plug-in pipe | 23 Gasket |
| 12 Pipe | 24 Screw |

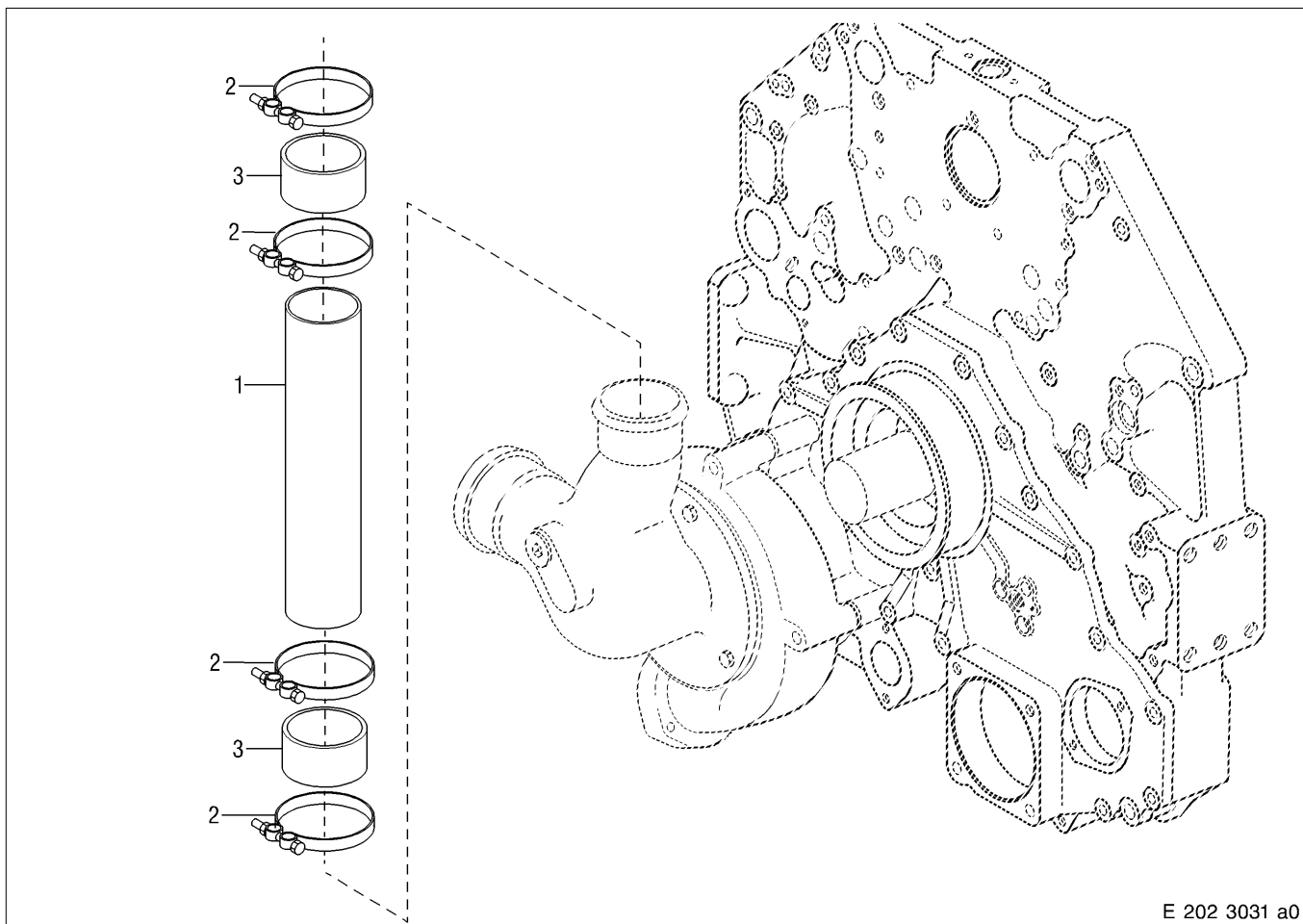

- 1 Coolant line
- 2 Hose clamp
- 3 Hose line

C 202.10.04 Before-Removal Operations

A distinction must be made as to whether:

- 1 ————— The engine is to be completely disassembled
- 2 ————— The engine is to be removed but not disassembled
- 3 ————— The engine is to remain installed

1	2	3	Operations	See
x	-	-	Remove engine	B 003
x	-	-	Perform operations as per Disassembly Plan	B 004
-	-	x	Disable engine start	Operating Instructions
-	-	x	Drain engine coolant	Operating Instructions
-	x	x	Disconnect monitoring units and remove	-

C 202.10.05 Removal

Disconnecting engine coolant lines

Note: Before removing lines, it is advisable to photograph the engine from all sides or attach metal tags to the lines and fixtures so that they can be reinstalled in their original positions.

Remove lines in accordance with General View – see C 202.10.01.

After removing lines, seal all open connections by installing suitable plugs.

C 202.10.08 Inspection and Repair

Clean lines with cold cleaner and brush.

Visually inspect all components, especially sealing and mating faces, for wear, pitting and cavitation; rub down with emery cloth or an oilstone or replace component.

If necessary, repair pipelines. If necessary, check for leaks with corrosion inhibitor with air in water bath .



WARNING

Compressed air is air which has been compressed under pressure. Risk of injury. Pressure must not exceed 0.5 bar (7.25 lb/in²). Always wear protective clothing, protective gloves and protective goggles/safety mask.

Coolant temperature min. 30 °C – components must also be at this temperature; max. 40 °C, if component must be held in hands.

Test pressure: 0.5 bar

Replace hose lines as part of every W6 overhaul.

Replace gaskets as part of every disassembly.

C 202.10.11 Installation

Connecting engine coolant lines



CAUTION

Compressed air is air which has been compressed under pressure. If compressed air is used for blowing out or blow-drying components, always wear protective goggles or safety mask. Compressed air must not be directed at the body. The pressure must not exceed 3.0 bar (40 lb/in²).

Prior to installing, remove all blanking plugs and blow lines clear with compressed air.

Install lines with new gaskets, hose lines and attachments free of tension as shown in General View – see C 202.10.01.

Note: After engine start, visually inspect lines for leaks.

C 202.10.12 After-Installation Operations

A distinction must be made as to whether:

- 1 — The engine was completely disassembled
- 2 — The engine is removed but was not disassembled
- 3 — The engine is installed

1	2	3	Operations	See
x	—	—	Perform operations as per Assembly Plan	B 005
x	—	—	Install engine	B 007
—	x	x	Install monitoring units and connect	—
—	—	x	Fill engine coolant system	Operating Instructions
—	—	x	Release engine start	Operating Instructions



C 206.05 Coolant Distribution Housing and Thermostat

C 206.05.01 General View

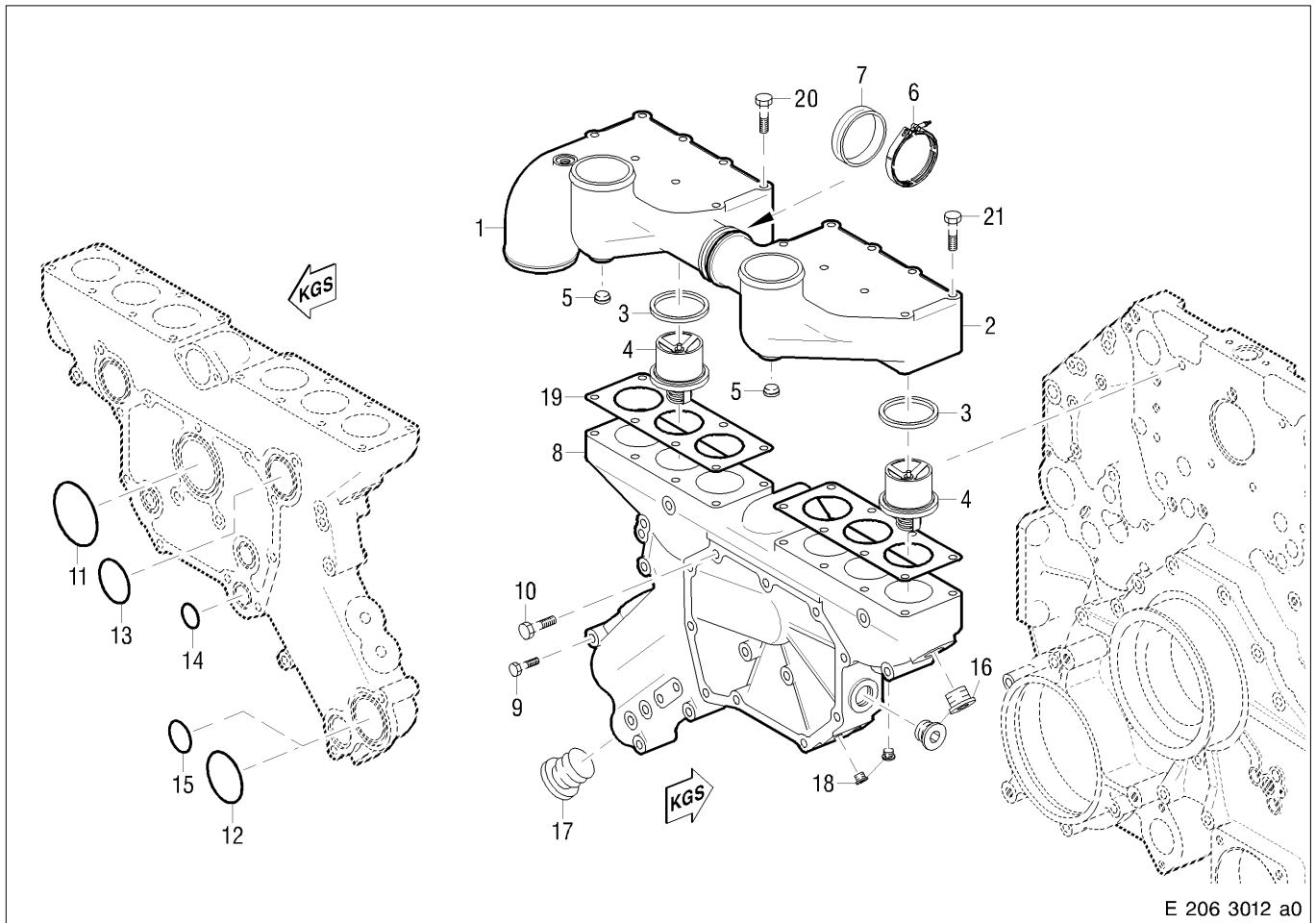

E 206 3012 a0

- | | | |
|-------------------------|--------------------------------|-----------------|
| 1 Thermostat housing | 8 Coolant distribution housing | 15 Sealing ring |
| 2 Thermostat housing | 9 Screw | 16 Plug |
| 3 Sealing ring (Teflon) | 10 Screw | 17 Plug |
| 4 Thermostat insert | 11 Sealing ring | 18 Plug |
| 5 Ventilation nipple | 12 Sealing ring | 19 Gasket |
| 6 Band clamp | 13 Sealing ring | 20 Screw |
| 7 Sleeve | 14 Sealing ring | |

C 206.05.02 Special Tool

Designation – Application

Number

Press-in mandrel for sealing ring (Teflon)

1

C 206.05.04 Before-Removal Operations

A distinction must be made as to whether:

- 1 ————— The engine is to be completely disassembled
- 2 ————— The engine is to be removed but not disassembled
- 3 ————— The engine is to remain installed

1	2	3	Operations	See
x	—	—	Remove engine	B 003
x	—	—	Perform operations as per Disassembly Plan	B 004
—	—	x	Disable engine start	Operating Instructions
—	—	x	Drain engine coolant	Operating Instructions
—	x	x	Disconnect electric cables	—
—	x	x	Disconnect fuel lines	C 082.05/C 084.05
—	x	x	Remove coolant lines	C 202.15
—	x	x	Remove oil lines	C 181.20
—	x	x	Remove fan drive*	C 221.05
—	x	x	Remove V-ribbed belt	C 028.05
—	x	x	Remove generator tensioner	C 028.05

* – not always applicable (order-specific) –

C 206.05.05 Removal

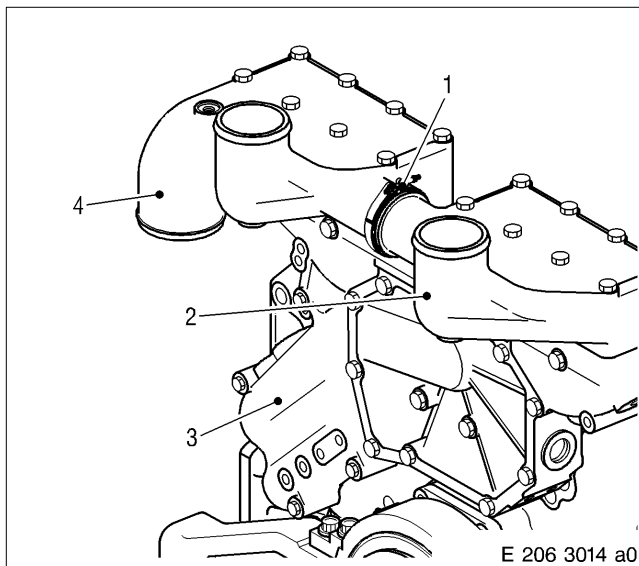

Removing thermostat housing and thermostat inserts

Remove securing screws for thermostat housing (2) and (4) and remove thermostat housing from coolant distribution housing (3).

Remove band clamp (1) and sleeve.

Remove thermostat inserts and loose slit pin from thermostat housing.

Remove sealing rings (Teflon) – see General View – C 206.05.01 with suitable extractor from thermostat housing.

Remove gaskets.

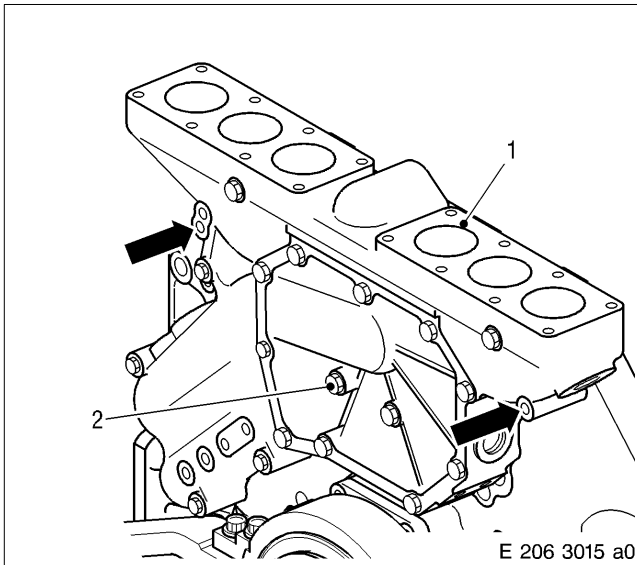

Removing coolant pipework housing

Insert two suitable guide pins in two opposing threaded bores (arrows) in crankcase.

Remove securing screws (2) and remove coolant distribution housing (1) via guide pin.

Remove sealing rings.

After removal, seal all connections with suitable plugs.

Remove guide pins.

C 206.05.08 Inspection and Repair

Clean all parts with cold cleaner.

Check components for damage and defects; replace components as necessary.

Pressure-test coolant distribution housing and thermostat housing with air in water bath (with corrosion inhibitor).



WARNING

Compressed air is air which has been compressed under pressure. Risk of injury. Pressure must not exceed 0.5 bar (7.25 lb/in²). Always wear protective clothing, protective gloves and protective goggles/safety mask.

Coolant temperature min. 30 °C – components must also be at this temperature; max. 40 °C, if component must be held in hands.

Test pressure: 0.5 bar

If leaks are found, replace component.

Replace blanking plugs if necessary (e.g. if leaking) .

Check all mating and sealing faces for wear and damage; rub down with emery cloth or an oilstone as necessary.

Check condition of thread in coolant distribution housing; replace thread insert if necessary.

Replace sealing rings (Teflon) and sleeve as part of every W6.

Replace gaskets and sealing rings as part of every disassembly.

Make sure that oil chambers are perfectly clean.

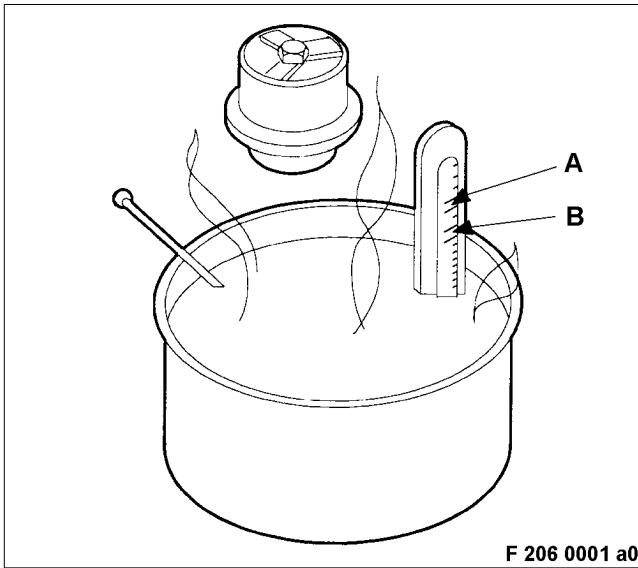

Checking thermostat insert

Hang thermostat insert on a wire in a container filled with water; thermostat insert must not contact container.

Heat water with suitable heat source.

As of approx. 10 °C under start-of-opening temperature (B), the heating speed must not exceed 1 °C per minute.

Start-of-opening temperature is stamped on thermostat insert.

Note: Never use welding torch or blow torch to heat thermostat insert!

CAUTION

**Component is hot.
Risk of injury!
Touch components only when wearing protective gloves.**

Check thermostat insert for start of opening with heat supply uniform and water constantly circulated.

Replace thermostat insert if results of check are negative.

Continue to heat coolant to full-opening temperature (A).

Full-opening temperature = 87 °C

Thermostat insert must be completely open after 6 to 8 minutes.

Measure stroke travel of thermostat insert.

Stroke must be 9.5 mm; if not, replace thermostat insert.

C 206.05.11 Installation

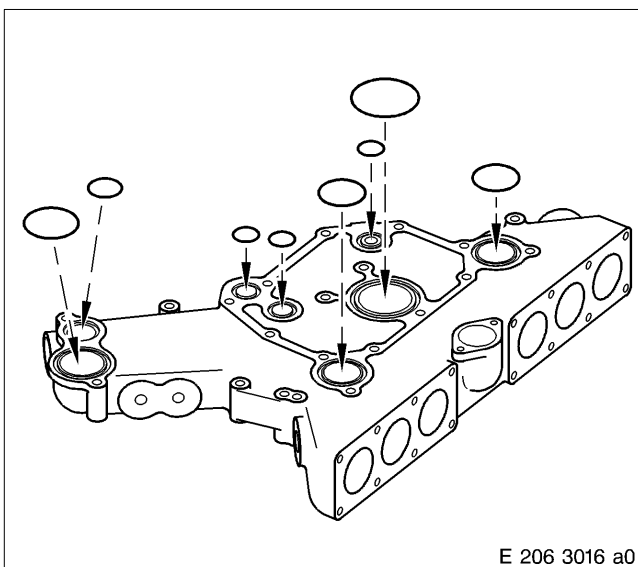

Installing coolant control housing

Ensure that oil bores and oil chambers in coolant distribution housing and in gear case are perfectly clean.

Check sealing and mating faces and clean if necessary.

Complete coolant distribution housing as shown in General View – see C 206.05.01.

Coat sealing rings with petroleum jelly before installing.

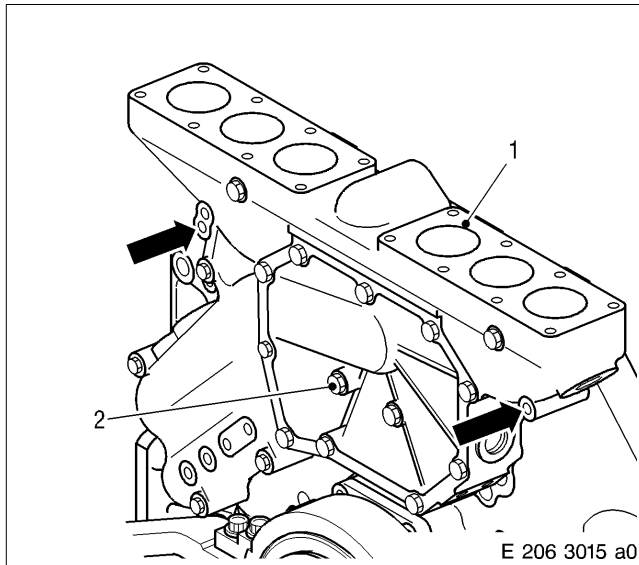

Insert two suitable guide pins in two opposing threaded bores (arrows) in crankcase.

Mount coolant distribution housing (1) on gear case via guide pins as shown in General View – see C 206.05.01 and tighten with screws (2).

Remove guide pins.

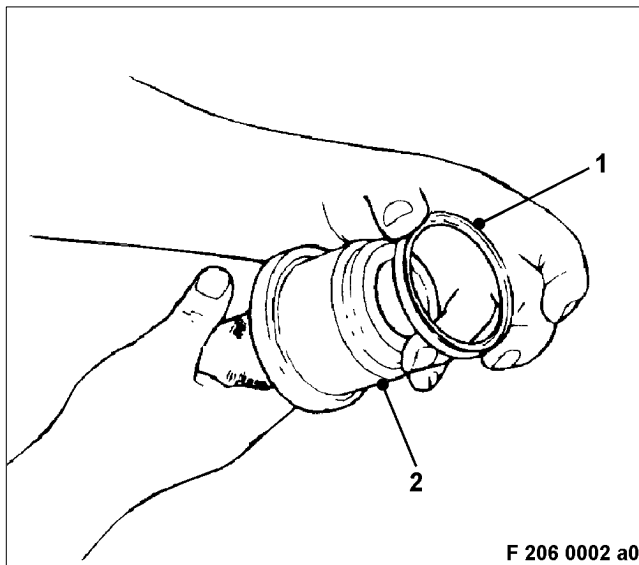

Installing sealing ring (Teflon) into thermostat housing

Fit sealing ring (1) on press-in mandrel, with flat end facing press-in mandrel (2).

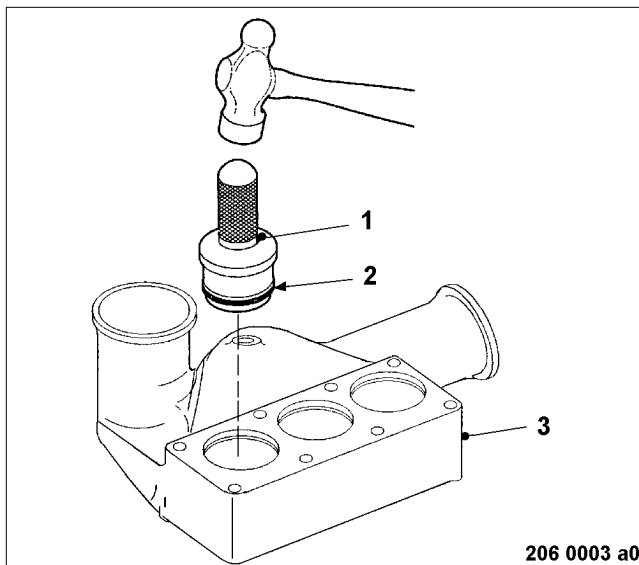

Check sealing and mating faces in thermostat housing (3), clean as necessary.

Using press-in mandrel (1), drive sealing rings (2) into thermostat housing until press-in mandrel contacts thermostat housing as shown in General View – see C 206.05.01.

Note: When driving in sealing rings, turn press-in mandrel so that sealing rings in thermostat housing are at same height.

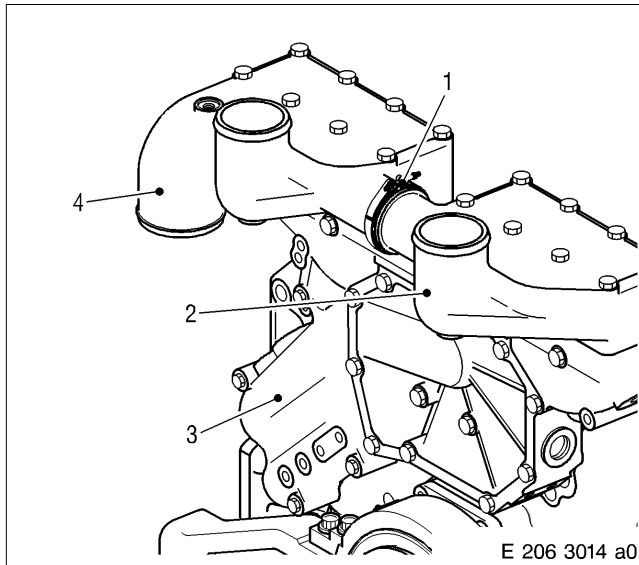

Install thermostat housing and thermostat inserts

Check sealing and mating faces and clean if necessary.

Insert loose split pin into vent bore in both thermostat housings (2) and (4).

Press thermostat inserts (6x) manually into thermostat housing as shown in General View – see C 206.05.01.

Preinstall sleeve and band clamp (1) on thermostat housing; do not tighten band clamp.

Fit gaskets on sealing surfaces on coolant distribution housing (3).

Mount thermostat housing with screws and then tighten band clamp.

C 206.05.12 After-Installation Operations

A distinction must be made as to whether:

- 1 ————— The engine is to be completely disassembled
- 2 ————— The engine is to be removed but not disassembled
- 3 ————— The engine is to remain installed

1	2	3	Operations	See
x	–	–	Perform operations as per Assembly Plan	B 005
x	–	–	Install engine	B 007
–	x	x	Install fan drive	C 221.05
–	x	x	Connect coolant lines	C 202.15
–	x	x	Install fuel lines	C 082.05/C 084.05
–	x	x	Install oil lines	C 181.20
–	x	x	Install generator tensioner	C028.05
–	x	x	Install V-belt	C 028.05
–	x	x	Connect electric cables	–
–	–	x	Fill engine coolant system	Operating Instructions
–	–	x	Release engine start	Operating Instructions

Contents

C 210 Power Supply, Engine Side

C 213.05 Generator

C 213.05.01 General view

C 213.05.04 Before-removal operations

C 213.05.05 Removal

C 213.05.06 Disassembly

C 213.05.08 Inspection and repair

C 213.05.10 Assembly

C 213.05.11 Installation

C 213.05.12 After-installation operations

C 210 Power Supply, Engine Side

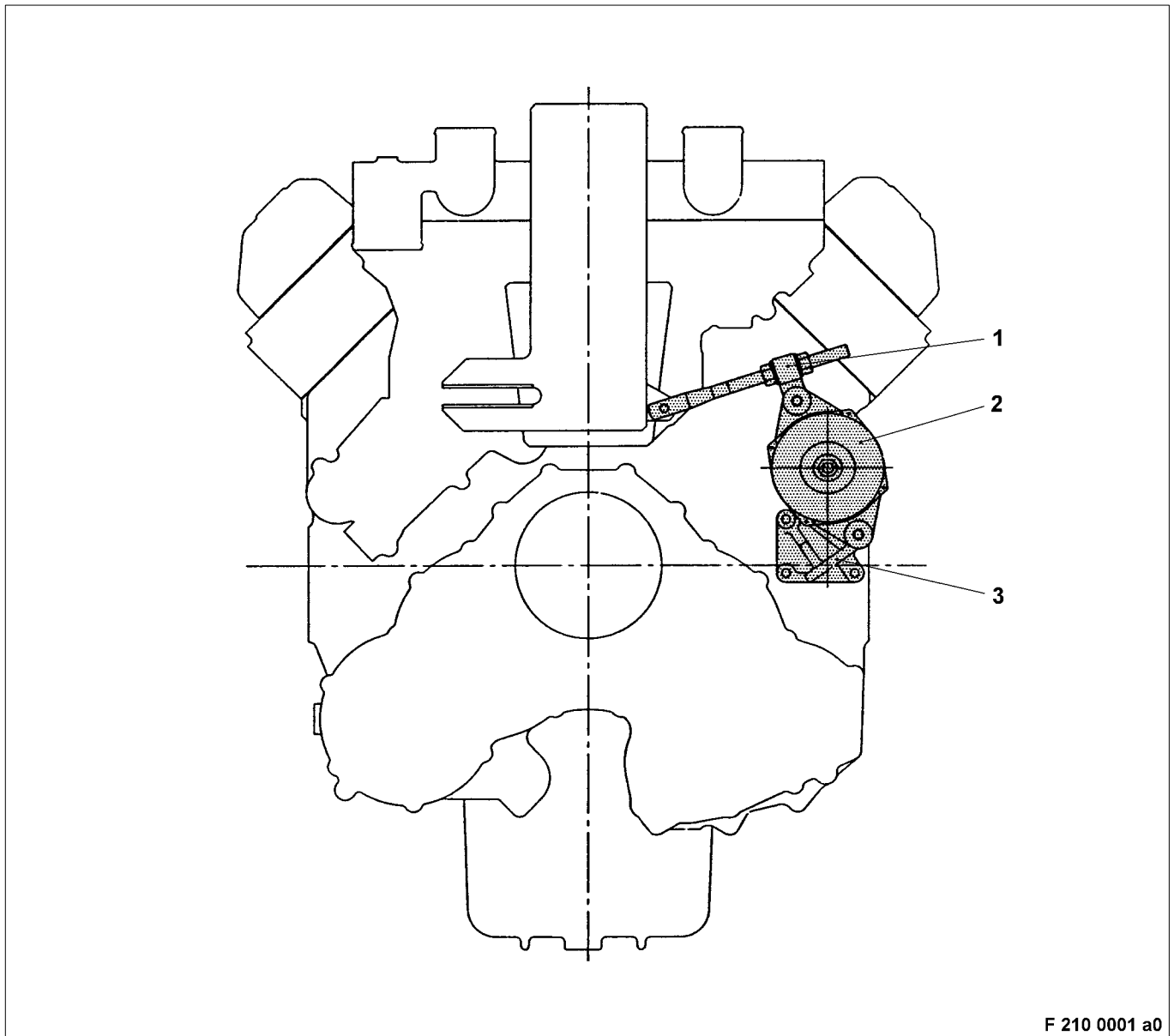

- 1 Clamping element
- 2 Generator
- 3 Carrier

The following is a list of auxiliary equipment and materials needed for the assembly operations:

 CAUTION
When using these chemical substances, it is essential to observe the Manufacturer's Instructions for use, safety instructions and waste disposal specifications.

Materials and consumables	Designation	Order No.		Remarks
		MTU	DDC	
Emery cloth				
Magnifying glass				
Engine oil				
Cleaning agent	Solvclean KW	40022		
Corrosion preventive	Caramba Express	40008		
Kerosene or diesel fuel				
Dry compressed air				



C 213.05 Generator

C 213.05.01 General View

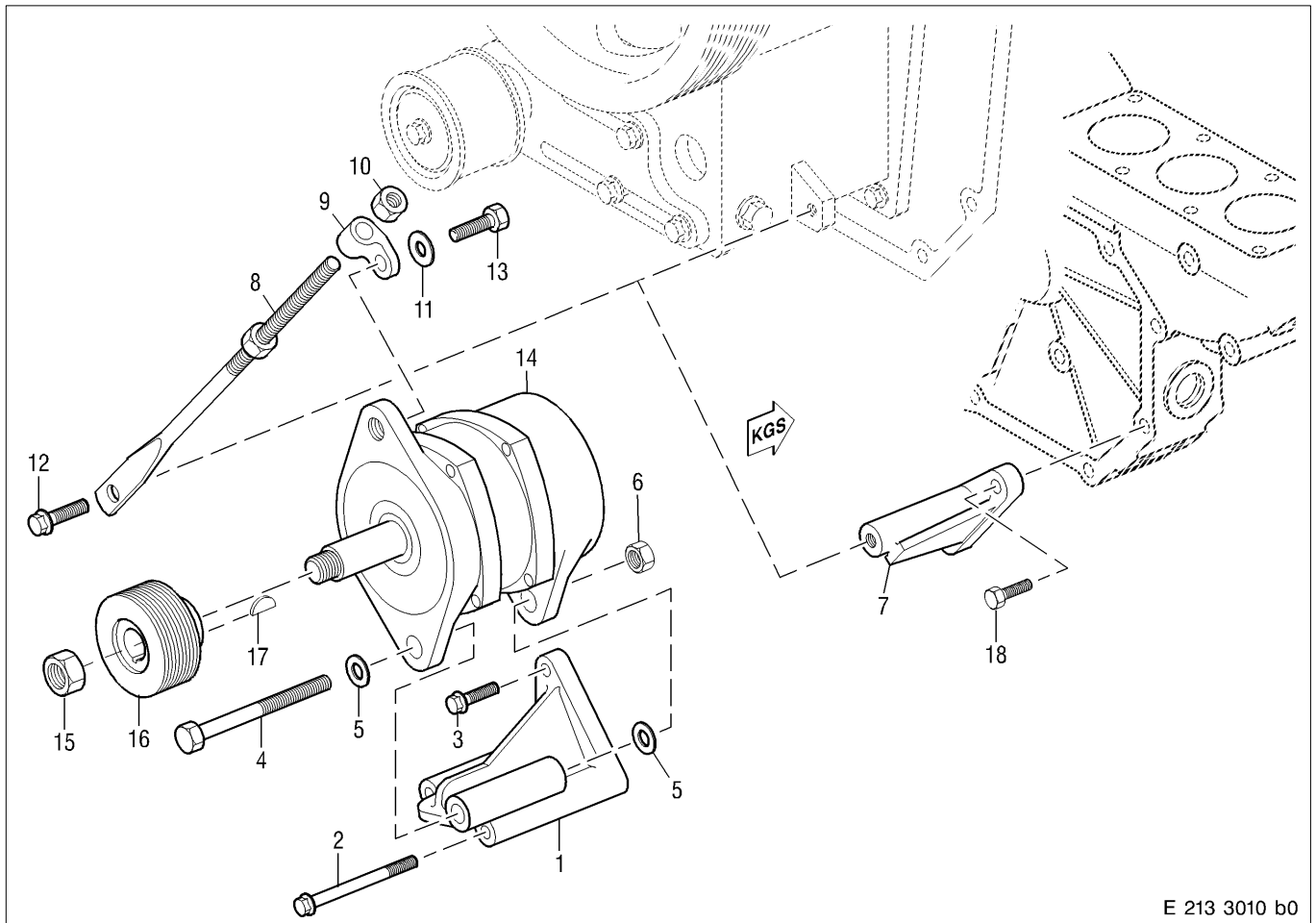

E 213 3010 b0

- | | | |
|----------------------------------|-----------------------|----------------------------------|
| 1 Bracket | 12 Screw | Tightening torque: 82 Nm + 12 Nm |
| 2 Hex screw | Lubricant: Engine oil | |
| 3 Screw | 13 Hex screw | Tightening torque: 82 Nm + 12 Nm |
| 4 Hex screw | Lubricant: Engine oil | |
| Tightening torque: 82 Nm + 12 Nm | 14 Generator | |
| Lubricant: Engine oil | 15 Nut | Tightening torque: 95 Nm + 13 Nm |
| 5 Washer | Lubricant: Engine oil | |
| 6 Nut | 16 Belt pulley | |
| 7 Bracket | 17 Woodruff key | |
| 8 Stress bolt | 18 Screw | |
| 9 Link | | |
| 10 Nut | | |
| 11 Washer | | |

C 213.05.04 Before-Removal Operations

A distinction must be made as to whether:

- 1 — The engine is to be completely disassembled
- 2 — The engine is to be removed but not disassembled
- 3 — The engine is to remain installed

1	2	3	Operations	See
x	-	-	Remove engine	B 003
x	-	-	Perform operations as per Disassembly Plan	B 004
-	-	x	Disable engine start	Operating Instructions
-	x	x	Mark and disconnect electric cables	-
-	x	x	Remove protective guard	-

C 213.05.05 Removal

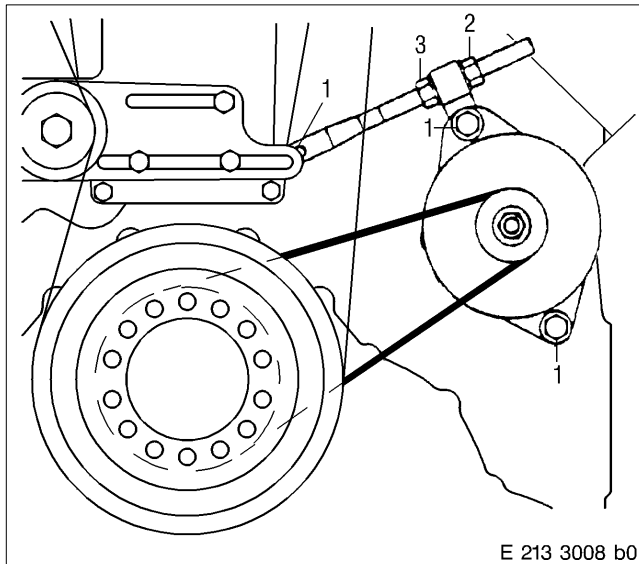

Removing generator

Note: Before removal, ensure that the negative battery pole is disconnected!

Remove V-belt – see C 028.05.

Remove securing screws (1) (thereby ensuring generator cannot fall out of position), remove stress bolt and generator.

Remove locknut (2) and clamping nut (3) and remove link from stress bolt.

Remove bracket for generator from crankcase as shown in General View – see C 213.05.01.

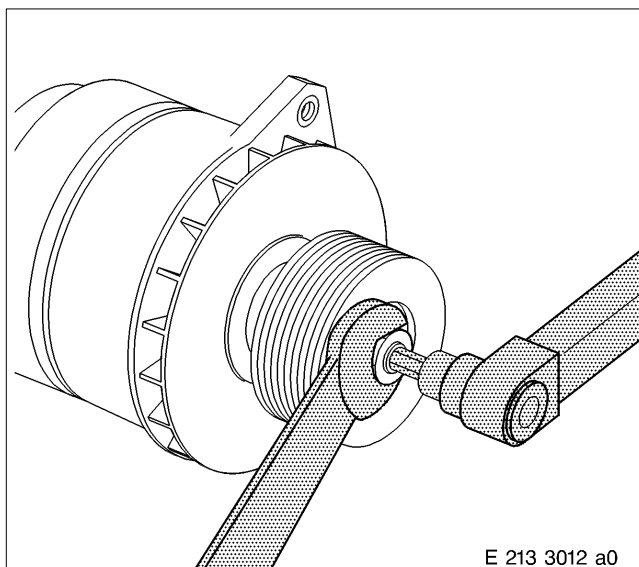

Removing belt pulley from generator

Remove nut while holding generator shaft in position with Allen key.

Remove belt pulley from shaft.

Remove woodruff key from shaft.

C 213.05.06 Disassembly

Disassemble generator – see Manufacturer’s Documentation.

C 213.05.08 Inspection and Repair

Visually inspect outside of generator for damage and defects.

Inspect and repair individual parts of generator in accordance with Manufacturer’s Documentation.

Clean all components and visually inspect condition and check for damage; replace component as necessary.

Check all mating faces and fits. Rub down with oilstone or emery cloth as necessary.

Check condition of threads; machine or replace components as necessary.

C 213.05.10 Assembly

Assemble generator – see Manufacturer’s Documentation.

C 213.05.11 Installation

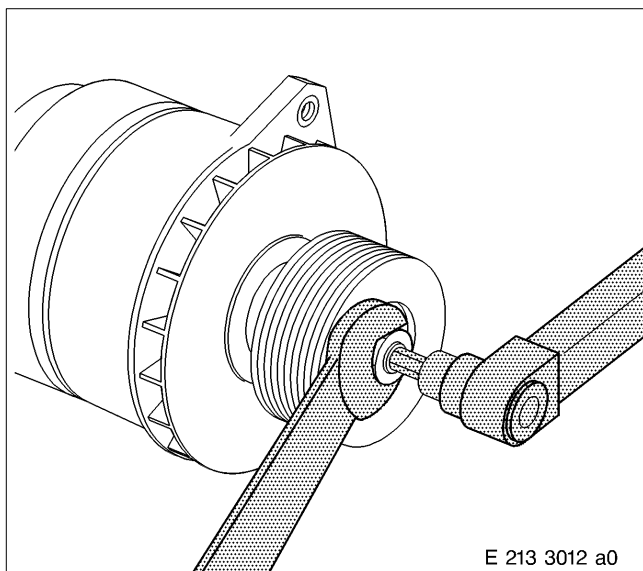

Mounting belt pulley on generator

Positioning correctly, position belt pulley on shaft as shown in General View – see C 213. 05.01; pay special attention to fit of woodruff key.

Fit nut and tighten to specified tightening torque – see C 213.05.01 – for this purpose, hold generator shaft in position with Allen key.

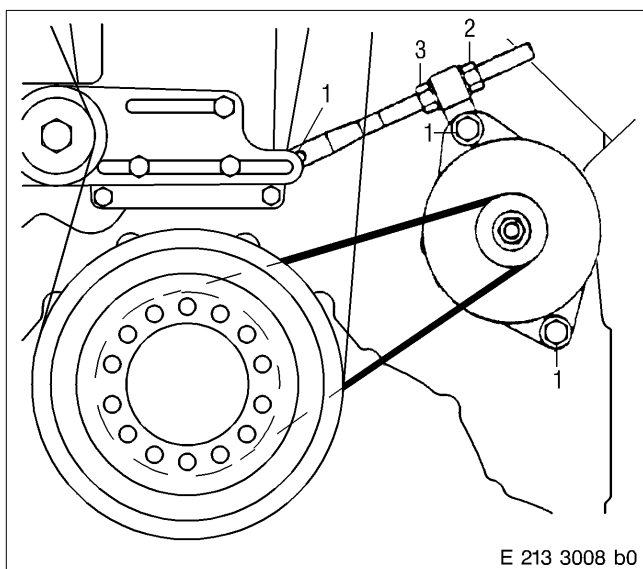

Installing generator

Install bracket on crankcase with hex bolts as shown in General View – see C 213.05.01.

Preinstall link with locknut (2) and clamping nut (3) on stress bolt.

Mount stress bolt and generator with securing screws (1); do not tighten.

Install V-belt and set V-belt tension – see C 028.05.11.

Tighten securing screws to specified tightening torque – see C 213.05.01.



C 213.05.12 After-Installation Operations

A distinction must be made as to whether:

- 1 — The engine is to be completely disassembled
- 2 — The engine is to be removed but not disassembled
- 3 — The engine is to remain installed

1	2	3	Operations	See
x	–	–	Perform operations as per Assembly Plan	B 005
x	–	–	Install engine	B 007
–	x	x	Connect electrical cable in accordance with markings	–
–	x	x	Mount protective guard	–
–	–	x	Release engine start	Operating Instructions

Contents

C 220	Cooling Air System
C 221.05	Mechanical fan drive
C 221.05.01	General view
C 221.05.02	Special tool
C 221.05.04	Before-removal operations
C 221.05.05	Removal
C 221.05.06	Disassembly
C 221.05.08	Inspection and repair
C 221.05.10	Assembly
C 221.05.11	Installation
C 221.05.12	After-installation operations

C 220 Cooling Air System

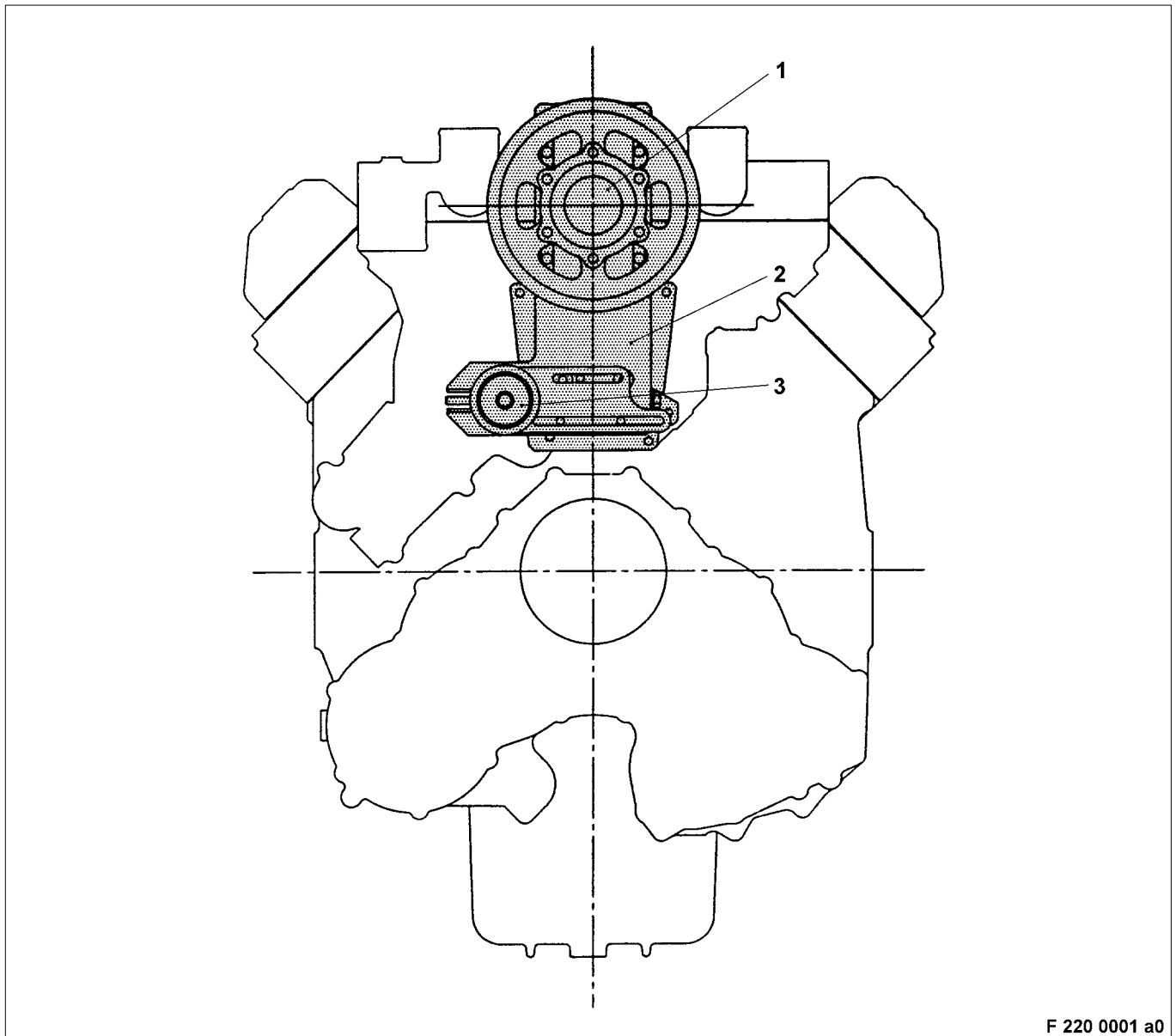

F 220 0001 a0

- 1 Bearing unit
- 2 Carrier
- 3 Belt tensioner

The following is a list of auxiliary equipment and materials needed for the assembly operations:

	CAUTION
<p>When using these chemical substances, it is essential to observe the Manufacturer's Instructions for use, safety instructions and waste disposal specifications.</p>	

Materials and consumables	Designation	Order No.		Remarks
		MTU	DDC	
Emery cloth				
Magnifying glass				
Engine oil				
Cleaning agent	Solvclean KW	40022		
Multipurpose grease	Texaco Premium RB			
Corrosion preventive	Caramba Express	40008		
Kerosene or diesel fuel				
Dry compressed air				
Surface crack-testing equipment with red penetrant dye				



C 221.05 Mechanical Fan Drive

C 221.05.01 General View

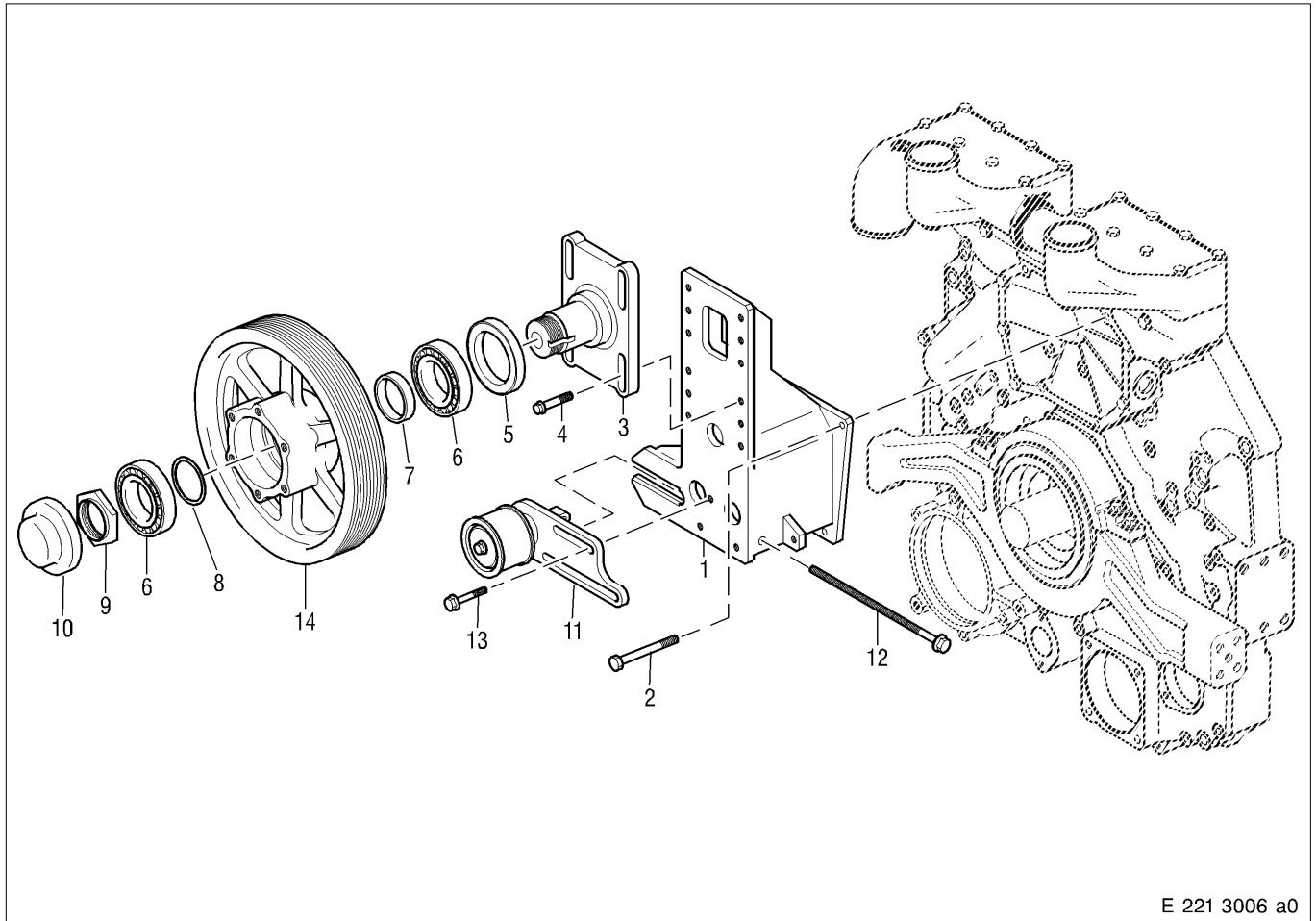

E 221 3006 a0

- | | |
|---------------------------|-----------------------------------|
| 1 Bracket | 8 Shim |
| 2 Screw | 9 Nut |
| 3 Bracket | Tightening torque: 339 Nm + 13 Nm |
| 4 Screw | Lubricant: Engine oil |
| Tightening torque: 100 Nm | 10 Protective cap |
| Lubricant: Engine oil | 11 Belt tensioner |
| 5 Gasket | 12 Screw |
| 6 Bearing | 13 Screw |
| 7 Spacer | 14 Belt pulley |

Belt tensioner

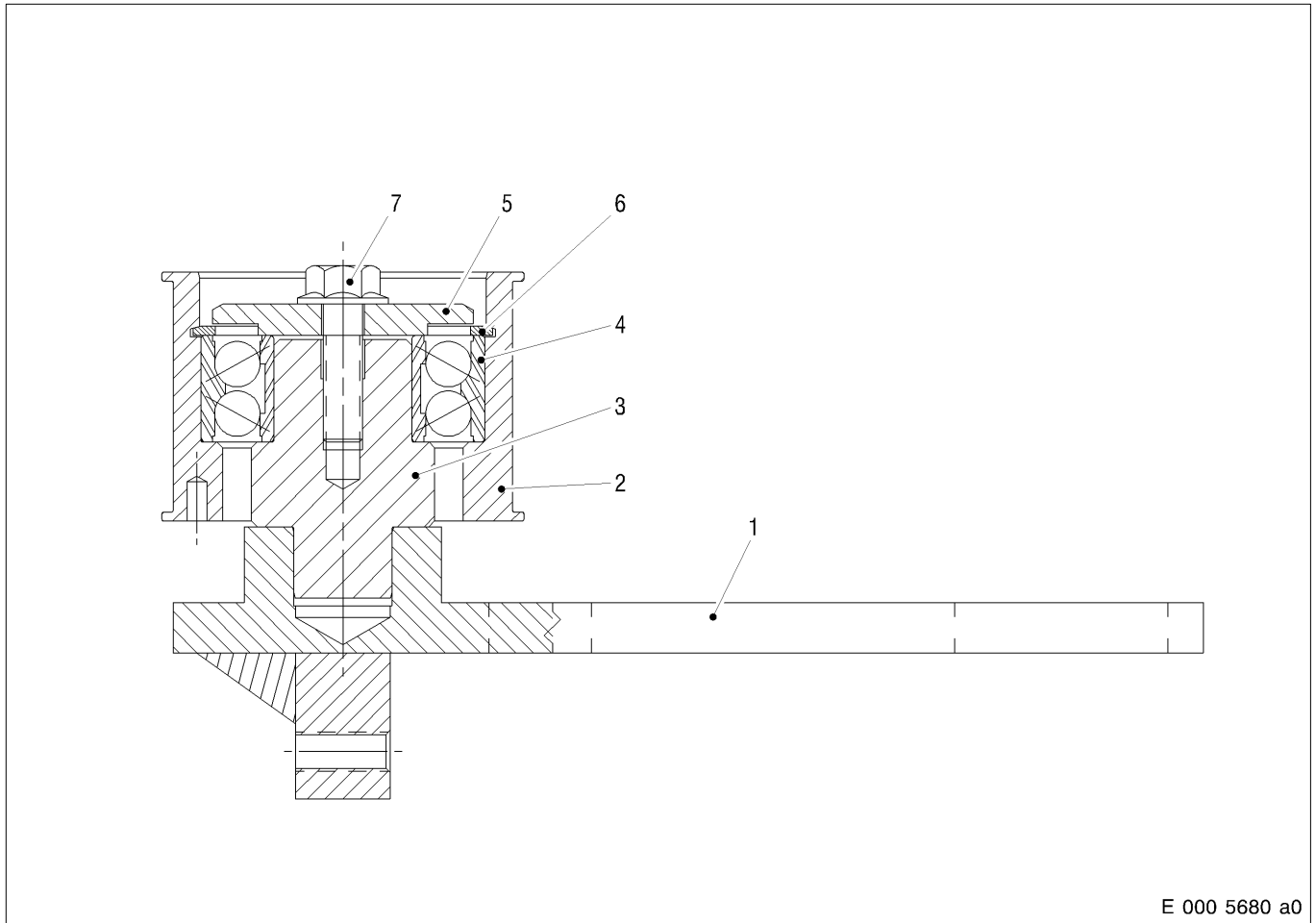

E 000 5680 a0

- | | |
|----------------|----------------------------------|
| 1 Spindle | 5 Washer |
| 2 Belt pulley | 6 Circlip |
| 3 Shaft | 7 Screw |
| 4 Ball bearing | Tightening torque: 58 Nm + 15 Nm |
| | Lubricant: Engine oil |

C 221.05.02 Special Tool

Designation – Application	Number
Press-in sleeve for bearing outer race in belt pulley	1
Press-in sleeve for end cover	1
Removal mandrel for ball bearing (belt tensioner)	1
Press-in sleeve for ball bearing (belt tensioner)	1

C 221.05.04 Before-Removal Operations

A distinction must be made as to whether:

- 1 ————— The engine is to be completely disassembled
- 2 ————— The engine is to be removed but not disassembled
- 3 ————— The engine is to remain installed

1	2	3	Operations	See
x	-	-	Remove engine	B 003
x	-	-	Perform operations as per Disassembly Plan	B 004
-	-	x	Disable engine start	Operating Instructions
-	x	x	Remove protective guard	-
-	x	x	Remove fan wheel	-
-	x	x	Remove V-belt	C 028.05

C 221.05.05 Removal

Removing bearing unit, belt tensioner and carrier for fan drive

Remove bearing unit, belt tensioner and carrier for fan drive as shown in General View – see C 221.05.01.

Set bearing unit and belt tensioner on suitable rest.

C 221.05.06 Disassembly

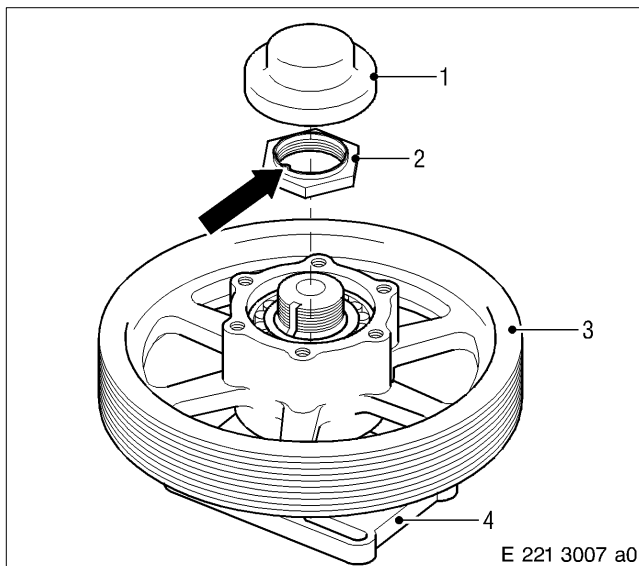

Disassembling bearing unit

Clamp bracket (4) in vice.

Pierce protective cap (1) with suitable tool and remove.

Note: Protective cap is damaged when removed and must not be reused!

Release nut (2) on lip (arrow) and remove.

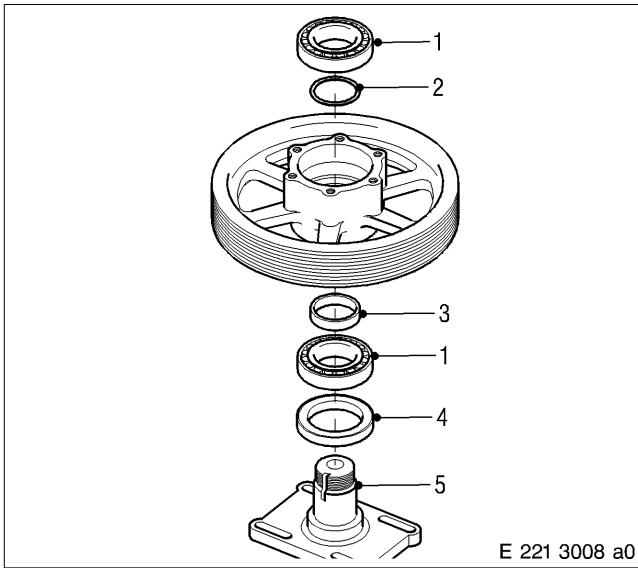

E 221 3008 a0

Note: When reusing bearings, take extra special care when carrying out removal operations; above all, do not apply removal force to rolling elements as there is risk of denting running surfaces of bearing.
 Bearing inner race and bearing outer race are seen as a single unit and must not be interchanged.

Using manual press and suitable mandrel, press bracket out of belt pulley.

Remove gasket (4) from belt pulley.

Remove bearing (1), spacer (3) and shims (2).

Note: To ensure that same washers are reinstalled during assembly, record number and thickness of shims removed.

Using brass mandrel and hammer, drive bearing outer races out of belt pulley; hammer evenly around the entire circumference.

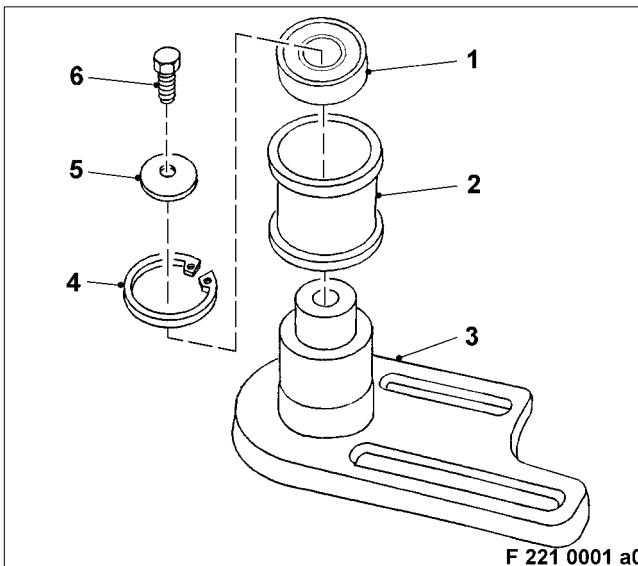

F 221 0001 a0

Disassembling belt tensioner

Clamp spindle (3) in vice.

Remove screw (6).

Remove washer (5).

	CAUTION
<p>Snap ring pretension. Risk of injury. Use suitable circlip pliers. Always wear protective goggles/safety mask.</p>	

Remove snap ring (4) with circlip pliers from belt pulley (2).

Remove belt pulley and ball bearing (1) from shaft.

Using manual press and suitable mandrel, press ball bearing out of belt pulley.

Note: When reusing bearings, take extra special care when carrying out removal operations; apply removal pressure only to ball bearing outer ring; never apply pressure to rolling elements!

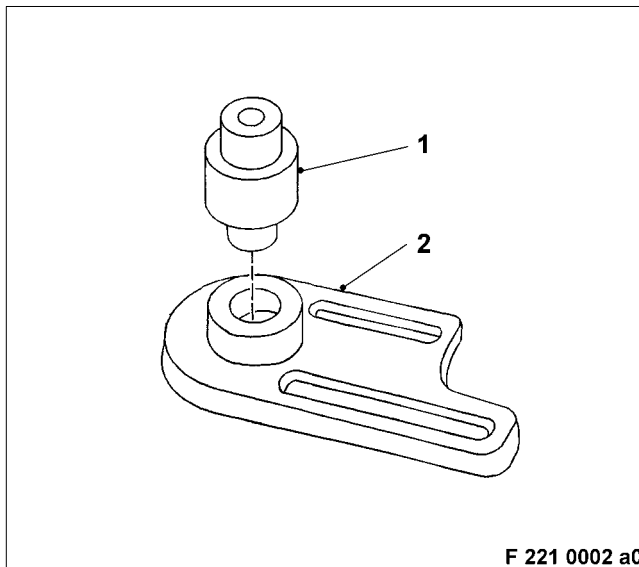

Note: Only remove shaft (1) if necessary (e.g. if damaged).

Use suitable extractor to remove shaft from spindle (2).

C 221.05.08 Inspection and Repair

Clean all components.



WARNING

Fuels and vapours mists are flammable and poisonous. Risk of fire, explosions and poisoning! When using fuel: – do not use naked flame – no electric sparks – do not smoke – do not spill fuel Do not inhale. Always wear protective gloves and protective goggles/safety mask. Ventilate working area well.

Clean bearings with fuel.

Visually inspect components, especially bearing roller element, for damage, wear and cracks.

Check bracket for cracks using surface crack-testing method.

In event of damage, wear or cracks, replace component.

Note: Bearing inner race and bearing outer race are seen as a single unit and must be replaced in pairs.

Check all mating faces and fits. Rub down with oilstone or emery cloth as necessary.

Adjust bore gauge and measure bearing bores in belt pulleys.

If limit values are exceeded (see Tolerances and Wear Limits List) replace components.

Check condition of threads; rechase threads if necessary.

Replace protective cap and gasket as part of every disassembly.

Replace bearing as part of every W6 overhaul.

C 221.05.10 Assembly

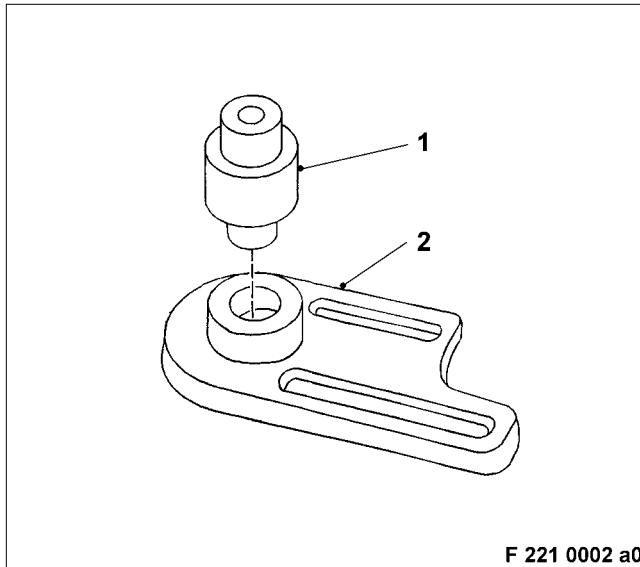

Assembling belt tensioner

Measure register bore in spindle (2) and journal outer diameter of shaft (1).

Check contact dimension of journal outer diameter with regard to spindle bore; see Tolerances and Wear Limits List.

Use manual press to press shaft into spindle until the stop.

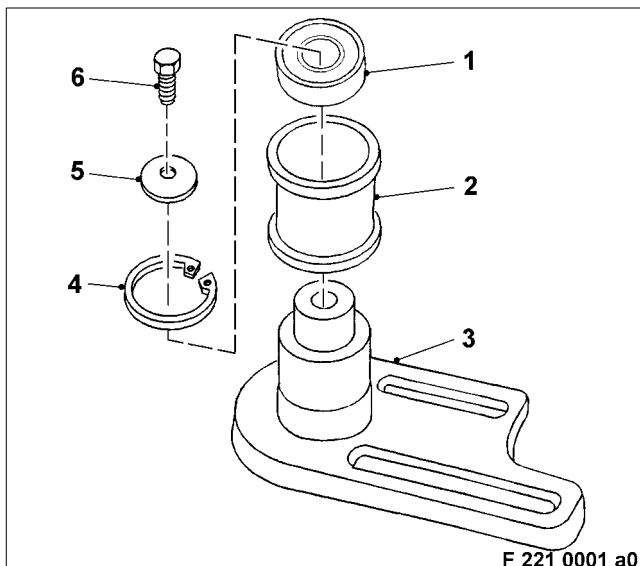

Note: Make sure parts are perfectly clean.

Using manual press and suitable press-in sleeve, press ball bearing (1) into belt pulley (2) until it contacts the stop – also see General View.

Note: Only apply installation pressure to ball bearing outer ring, not to rolling elements!

Fit belt pulley and ball bearing on shaft.

Clamp spindle (3) in vice.

CAUTION

**Snap ring pretension.
Risk of injury.
Use suitable circlip pliers. Always wear protective goggles/safety mask.**

Using circlip pliers, insert snap ring (4) into belt pulley

Note: Basil on snap ring faces outwards. Make sure that snap ring is correctly seated.

Positioning correctly, fit washer (5) (basil facing outwards) and tighten screw (6) to specified tightening torque – see C 221.05.01.

Turn belt pulley to check it for ease of movement; pulley must turn easily without obstruction.

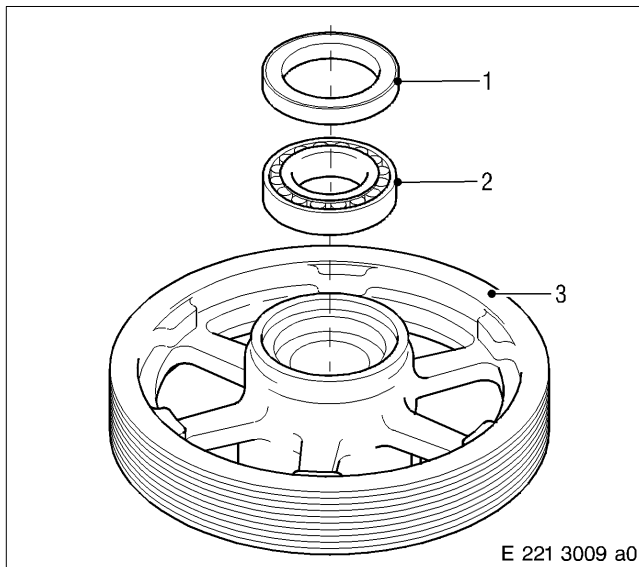

Assembling bearing unit

Note: Make sure parts are perfectly clean.

Check register bore in belt pulley (3); clean as necessary and apply a thin film of lubricant to bearing seat points.

Lubricate both bearing inner races well. Press multi-purpose grease also between cage, inner race and rollers.

Note: Bearing inner race and bearing outer race are seen as a single unit and must not be interchanged.

Using manual press and press-in sleeve, press bearing outer race of bearing (2) into belt pulley until the stop.

Note: Marked bearing ring end must point outwards.

Insert inner race into bearing outer race.

Using press-in sleeve and manual press, press new gasket (1) (with marking outwards), into belt pulley until the stop.

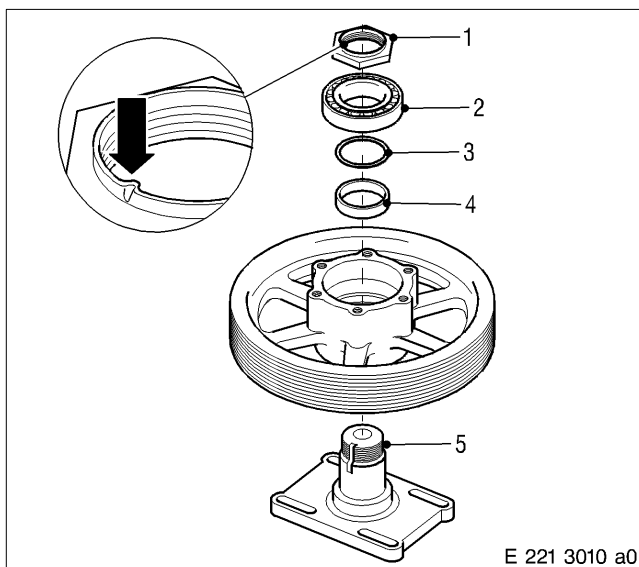

Using manual press and press-in sleeve, press bearing outer race of bearing (2) into belt pulley until the stop.

Note: Marked bearing ring end must point outwards.

Clamp bracket (5) in vice.

Fit belt pulley over axle of bracket; ensure that gasket is not damaged.

Fit spacer (4) and shims (3) over axle of bracket.

Note: Number and thickness of shims to be installed must be identical to washers removed.

Fill hollow chamber between bearings in belt pulley to 20 to 30% with multi-purpose grease.

Fit bearing inner race over axle of bracket.

Fit nut (1) and, turning belt pulley simultaneously, tighten to specified tightening torque – see C 221.05.01.

Turn belt pulley to check it for ease of movement; pulley must turn easily without obstruction.

After measuring axial clearance, see following Section, secure nut by pressing in lip (arrow) into groove of axle.

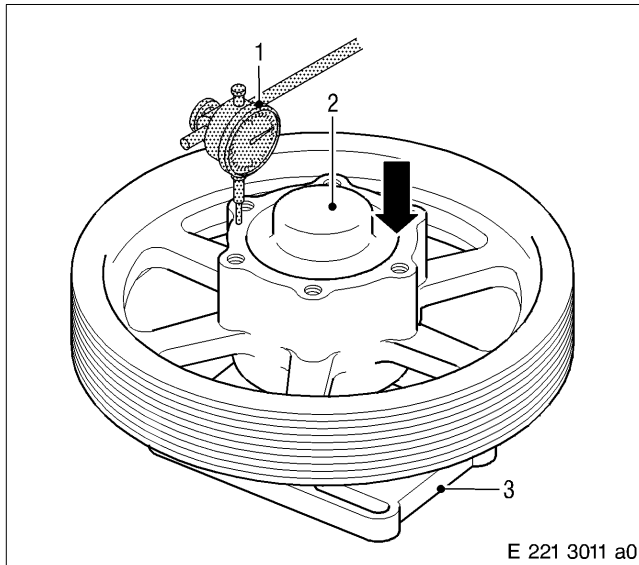

E 221 3011 a0

Mount magnetic dial gauge holder with dial gauge (1) on bracket.

Set dial gauge stylus with preload on end face of belt pulley and set dial gauge to zero.

Check axial play by moving belt pulley back and forth in axial direction.

If setpoint axial clearance drops below or exceeds specified value – see Tolerances and Wear Limits List – make setting with shims.

Note: Three shims of varying thickness are available.

Fill protective cap (2) 70 to 80% with multi-purpose grease.

Using manual press and press-in sleeve, press protective cap flush (arrow) into belt pulley.

Turn belt pulley to check it for ease of movement; pulley must turn easily without obstruction.

C 221.05.11 Installation

Installing fan drive carrier, bearing unit and belt tensioner

Install carrier for fan drive, bearing unit and belt tensioner as shown in General View – see C 221.05.01.

Tighten screws for bearing unit diagonally and evenly to specified tightening torque – see C 055.05.01.

C 221.05.12 After-Installation Operations

A distinction must be made as to whether:

- 1 ————— The engine is to be completely disassembled
- 2 ————— The engine is to be removed but not disassembled
- 3 ————— The engine is to remain installed

1	2	3	Operations	See
x	–	–	Perform operations as per Assembly Plan	B 005
x	–	–	Install engine	B 007
–	x	x	Install V-belt and setting V-belt tension	C 028.05
–	x	x	Install fan wheel	–
–	x	x	Mount protective guard	–
–	–	x	Release engine start	Operating Instructions

Contents

C 230	Mounting/Support
C 231.05	Engine mount
C 231.05.01	General view
C 231.05.02	Special tool
C 231.05.04	Before-removal operations
C 231.05.05	Removal
C 231.05.08	Inspection and repair
C 231.05.11	Installation
C 231.05.12	After-installation operations

C 230 Mounting/Support

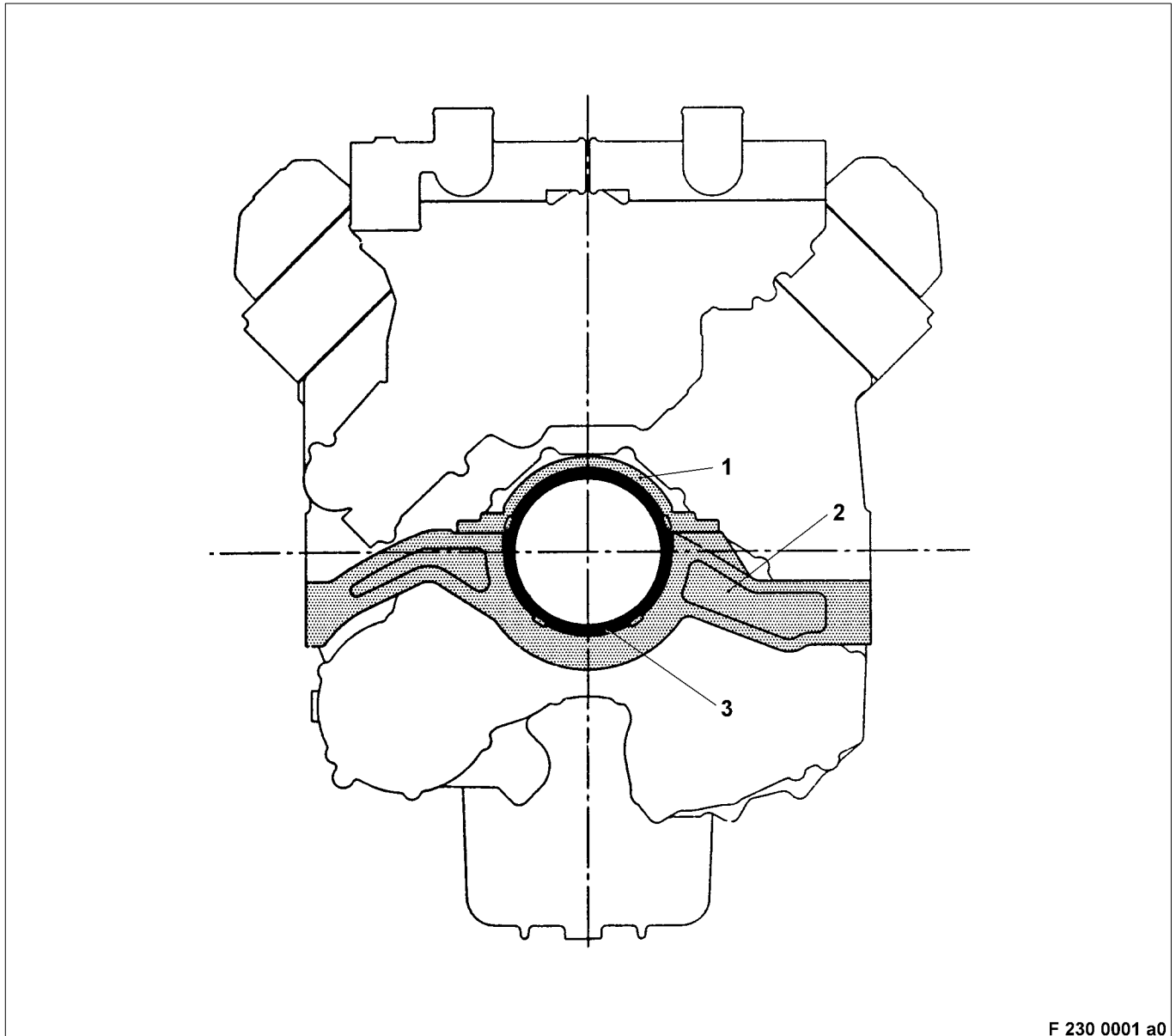

F 230 0001 a0

- 1 Cover
- 2 Carrier
- 3 Shock absorber

The following is a list of auxiliary equipment and materials needed for the assembly operations:



CAUTION

When using these chemical substances, it is essential to observe the Manufacturer's Instructions for use, safety instructions and waste disposal specifications.

Materials and consumables	Designation	Order No.		Remarks
		MTU	DDC	
Emery cloth				
Cleaning agent	Solvclean KW	40022		
Corrosion preventive	Caramba Express	40008		
Engine oil				
Dry compressed air				
Surface crack-testing equipment with red penetrant dye				



C 231.05 Engine Mount

C 231.05.01 General View

Engine mount, free end

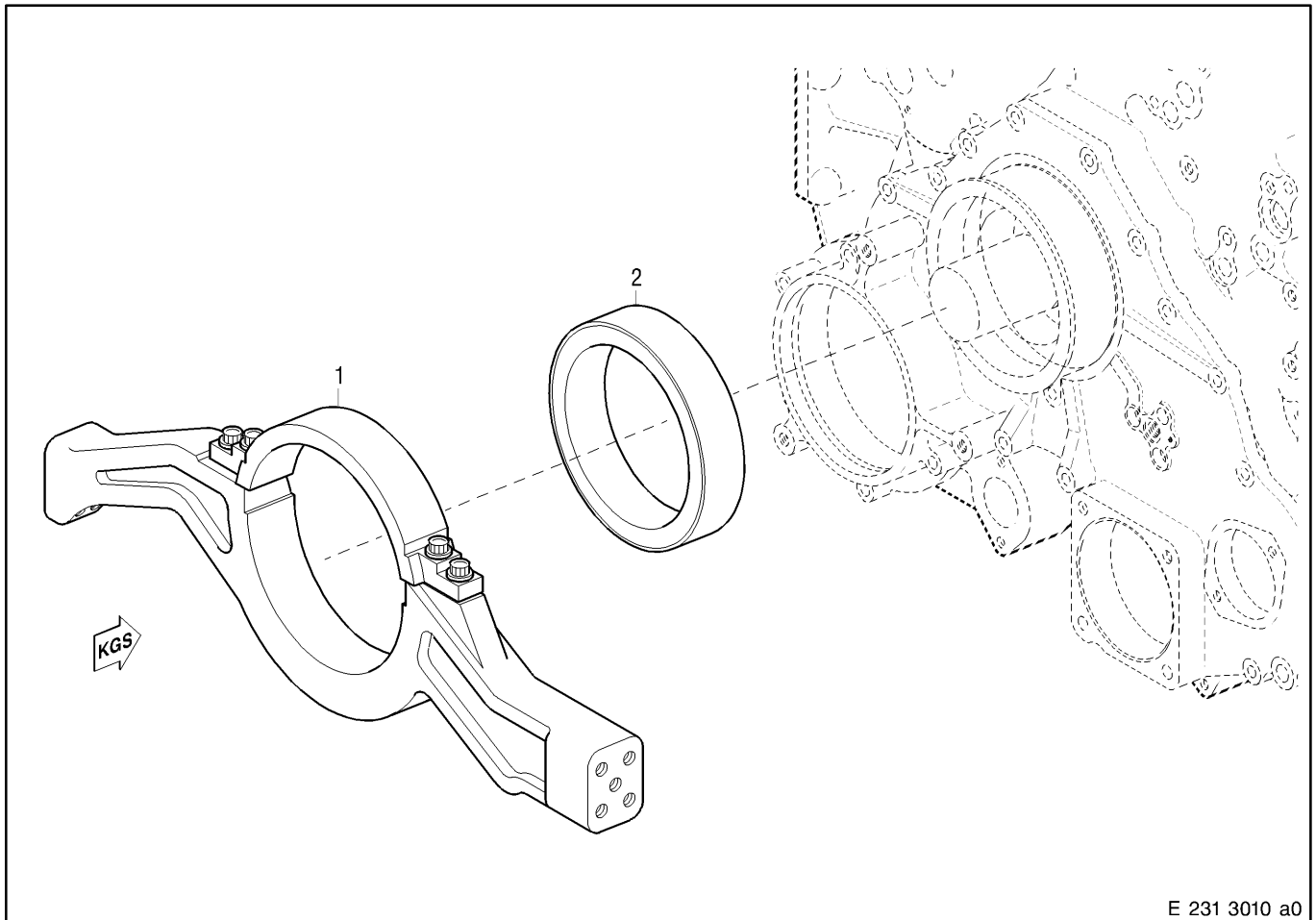

- 1 Engine carrier
- 2 Shock absorber

Engine mount, free end

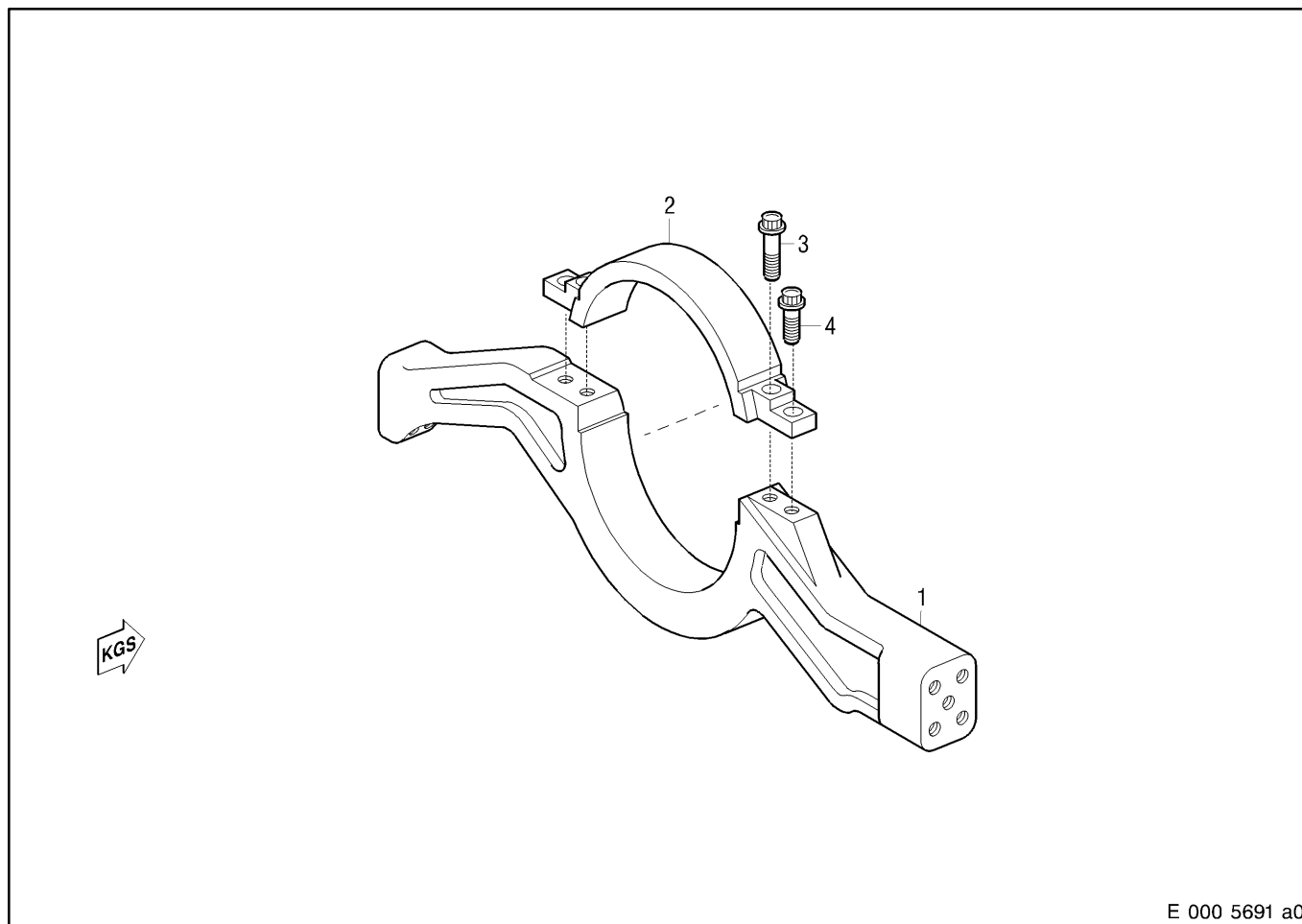

- 1 Carrier
- 2 Cover
- 3 Double-hex screw
Tightening torque: 260 Nm + 10 Nm
Lubricant: Engine oil
- 4 Double-hex screw
Tightening torque: 260 Nm + 10 Nm
Lubricant: Engine oil

C 231.05.02 Special Tool

Designation – Application	Number
Press-in mandrel for shock absorption	1

C 231.05.04 Before-Removal Operations

A distinction must be made as to whether:

- 1 ————— The engine is to be completely disassembled
- 2 ————— The engine is to be removed but not disassembled
- 3 ————— The engine is to remain installed

1	2	3	Operations	See
x	–	–	Remove engine	B 003
x	–	–	Perform operations as per Disassembly Plan	B 004
–	–	x	Disable engine start	Operating Instructions
–	–	x	Release foundation screw	–
–	x	x	Attach engine to lifting device.	–
–	–	x	Drain engine coolant*	Operating Instructions
–	–	x	Drain or draw off engine oil*	Operating Instructions
–	x	x	Disconnect fuel lines	C 082.05/C 084.05
–	x	x	Remove or disconnect electric wiring	–
–	x	x	Remove fuel delivery pump*	C 081.05
–	x	x	Remove V-belt*	C 028.05
–	x	x	Remove coolant lines*	C 202.15
–	x	x	Remove engine coolant pump*	C 202.05
–	x	x	Remove vibration damper*	C 035.05
–	x	x	Remove flange, free end*	C 035.05
–	x	x	Remove oil lines*	C 181.20
–	x	x	Remove generator*	C 213.05
–	x	x	Remove gear case cover*	C 024.05

* – only when replacing shock absorber –

C 231.05.05 Removal



WARNING

Engine can tilt. Risk of injury! Prior to removing engine mount, support or attach engine. Only use lifting device provided by manufacturer and observe lifting instructions.

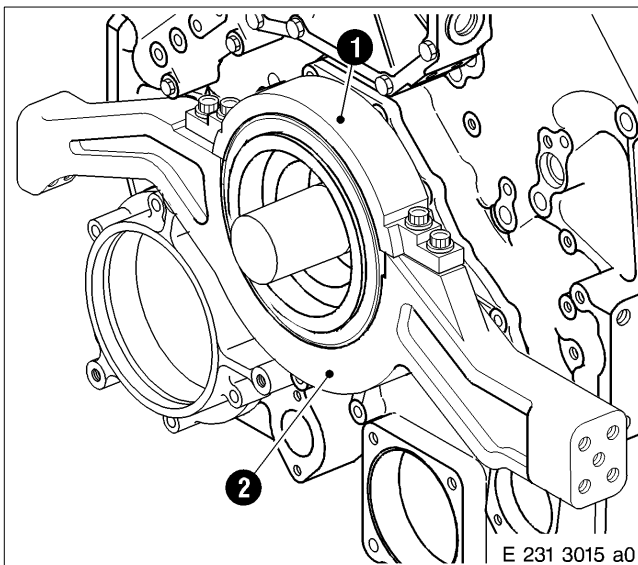

Removing engine mount, free end

Note: Protect shock absorber from exposure to oil and fuel!



WARNING

**Heavy object.
Risk of injury!
Use suitable tools and lifting equipment.**

Remove double-hex screws for cover (1) on carrier (2) (in doing so, hold carrier firmly in position) and remove cover and carrier

Removing shock absorber

Note: Only remove shock absorber if necessary (e.g. if damaged). Component is completely damaged during removal.

Cut shock absorber axially and remove from gear case cover.

C 231.05.08 Inspection and Repair

Note: Protect shock absorber from exposure to oil and fuel!

Clean all components.

Rub down shock absorber with dry cloth only, never use organic cleaning agents.

Using surface crack-testing method and red penetrant dye, check carrier and cover for cracks.

If cracks are detected, replace part.

Visually inspect shock absorber for damage, cracking and deformation; replace components as necessary.

Check all seating and mating faces for evenness; rub down with an oilstone or emery cloth as necessary.

Check thread in carrier for ease of movement; rechase threads as necessary.

Check double-hex screws for condition and thread for ease of movement; replace screw if necessary.

Replace shock absorber as part of every W6 overhaul.

C 231.05.11 Installation

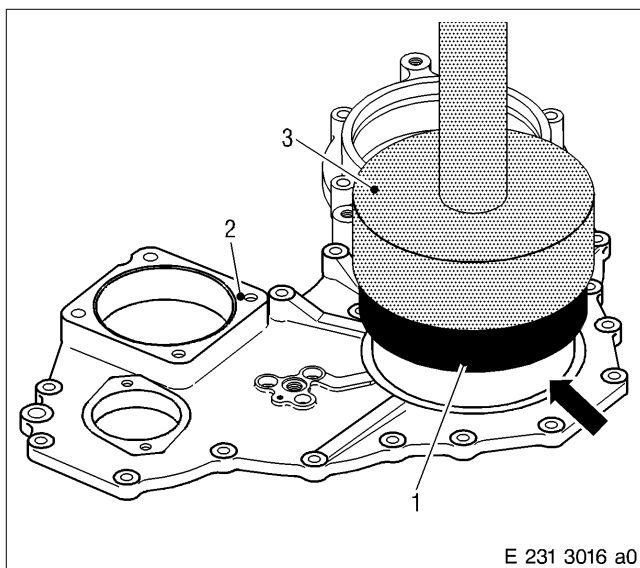

Installing shock absorber

Note: Before installing shock absorber, make sure all mating faces are metallically clean, i.e. remove all traces of oil and grease. Protect shock absorber from exposure to oil and fuel!

Coat mating face (arrow) on gear case cover (2) and in shock absorber (1) with soap-water solution.

Using manual press and press-in mandrel (3), press shock absorber onto gear case cover until the stop.

Install gear case cover, See C 024.05.

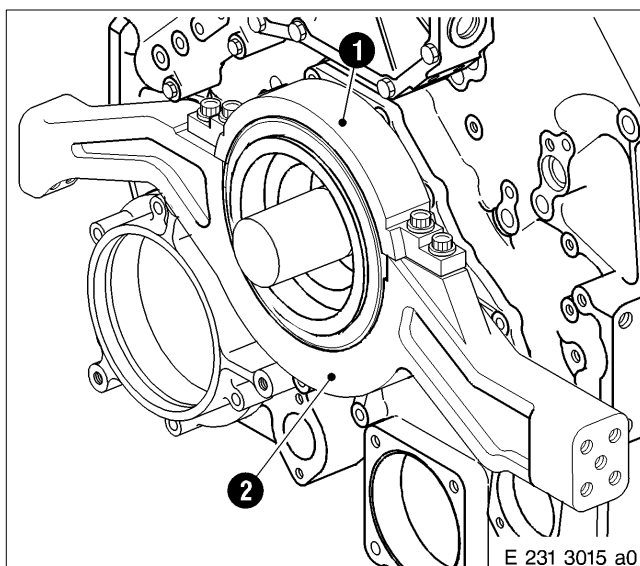

Installing engine mount, free end

Note: Protect shock absorber from exposure to oil and fuel!

! WARNING

**Heavy object.
Risk of injury!
Use suitable tools and lifting equipment.**

Check mating faces on carrier (2), cover (1) and on shock absorber; clean as necessary.

Install carrier and cover with double-hex screws on shock absorber.

Tighten double-hex bolts to specified tightening torque – see C 231.05.01.



C 231.05.12 After-Installation Operations

A distinction must be made as to whether:

- 1 ————— The engine is to be completely disassembled
- 2 ————— The engine is to be removed but not disassembled
- 3 ————— The engine is to remain installed

1	2	3	Operations	See
x	—	—	Perform operations as per Assembly Plan	B 005
x	—	—	Install engine	B 007
—	—	x	Secure engine mount to foundation.	—
—	x	x	Press on flange, free end*	C 035.05
—	x	x	Install vibration damper	C 035
—	x	x	Install engine coolant pump	C 202.05
—	x	x	Install fuel delivery pump	C 081.05
—	x	x	Install generator	C 213.05
—	x	x	Connect coolant lines	C 202.15
—	x	x	Install fuel lines	C 082.05/C 084.05
—	x	x	Install oil lines	C 181.20
—	x	x	Install V-belt and setting V-belt tension	C 028.05
—	x	x	Connect electric cables	—
—	—	x	Fill oil system with engine oil	Operating Instructions
—	—	x	Fill engine coolant system	Operating Instructions
—	—	x	Check engine alignment; realign if necessary	Special Publication
—	—	x	Release engine start	Operating Instructions

C 250 PTO Systems, Driving End and Free End (Coupling)

See Special Publication



Contents

C 360 Auxiliary Systems, Supplementary Units

C 362.40 Air compressor

- C 362.40.01 General view
- C 362.40.04 Before-removal operations
- C 362.40.05 Removal
- C 362.40.06 Disassembly
- C 362.40.08 Inspection and repair
- C 362.40.10 Assembly
- C 362.40.11 Installation
- C 362.40.12 After-installation operations

C 360 Auxiliary Systems, Supplementary Units

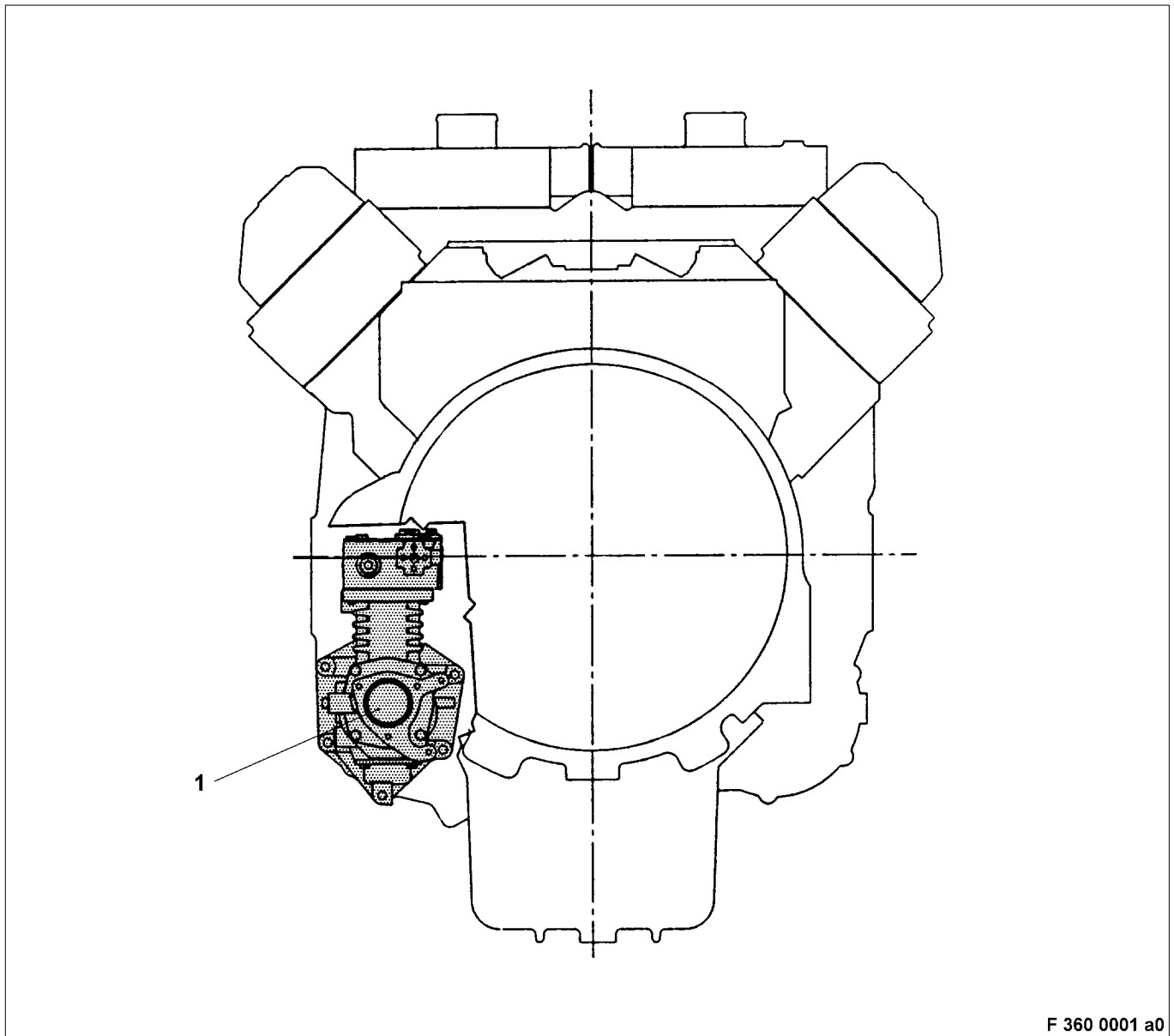

F 360 0001 a0

1 Air compressor

The following is a list of auxiliary equipment and materials needed for the assembly operations:

 CAUTION
When using these chemical substances, it is essential to observe the Manufacturer's Instructions for use, safety instructions and waste disposal specifications.

Materials and consumables	Designation	Order No.		Remarks
		MTU	DDC	
Emery cloth				
Magnifying glass				
Engine oil				
Cleaning agent	Solvclean KW	40022		
Corrosion preventive	Caramba Express	40008		
Kerosene or diesel fuel				
Dry compressed air				



C 362.40 Air Compressor

C 362.40.01 General View

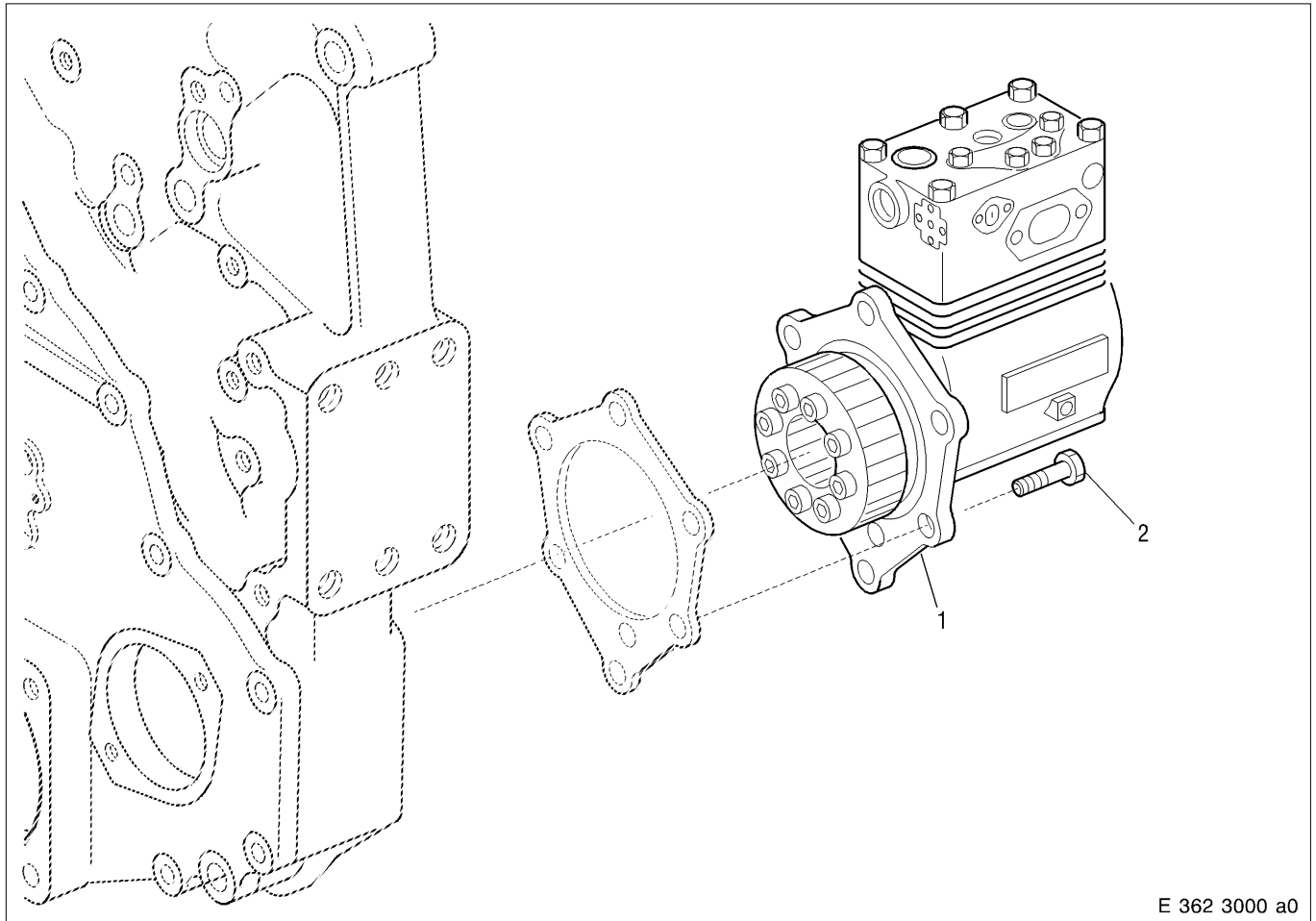

E 362 3000 a0

- 1 Air compressor
- 2 Screw

C 362.40.04 Before-Removal Operations

A distinction must be made as to whether:

- 1 ————— The engine is to be completely disassembled
- 2 ————— The engine is to be removed but not disassembled
- 3 ————— The engine is to remain installed

1	2	3	Operations	See
x	-	-	Remove engine	B 003
x	-	-	Perform operations as per Disassembly Plan	B 004
-	-	x	Disable engine start	Operating Instructions
-	-	x	Drain engine coolant	Operating Instructions
-	x	x	Remove compressed air lines	-

C 362.40.05 Removal

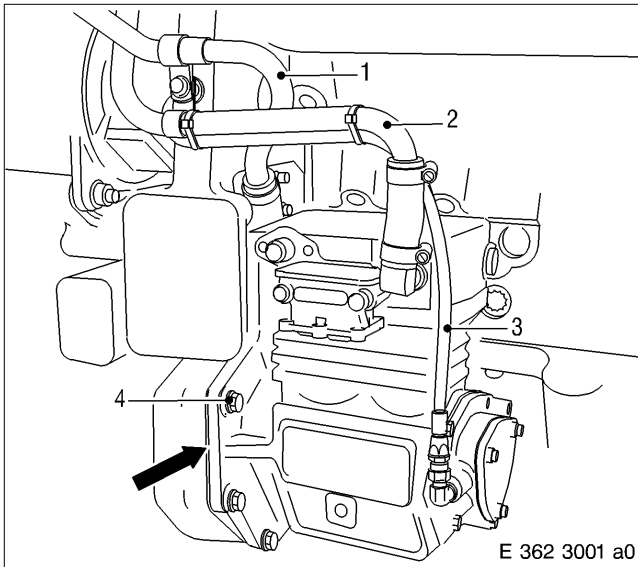

Removing air compressor

Remove coolant lines (1), (2) and oil line (3).

Unscrew securing screws (4) and nut on air compressor.

WARNING

**Heavy object.
Risk of injury!
Use suitable tools and lifting equipment.**

Withdraw air compressor from fit on gear case and remove.

Remove gasket (arrow).

If necessary, cover installation bore of air compressor.

C 362.40.06 Disassembly

See Manufacturer's Documentation.

C 362.40.08 Inspection and Repair

Inspect and repair air compressor in accordance with Manufacturer's Documentation.

Visually inspect outside of air compressor for damage and defects.

Check drive gear of air compressor for indentations and wear; rub down with an oilstone or emery cloth; replace drive gear as necessary.

Check all mating faces and fits. Rub down with oilstone or emery cloth as necessary.

Clean attachments and connecting parts and visually inspect condition and check for damage; replace components as necessary.

Check hose clamps and rubber sleeves for damage; replace as necessary.

Replace rubber sleeves as part of every W6 overhaul.

Replace gasket as part of every disassembly.

C 362.40.10 Assembly

See Manufacturer's Documentation.

C 362.40.11 Installation

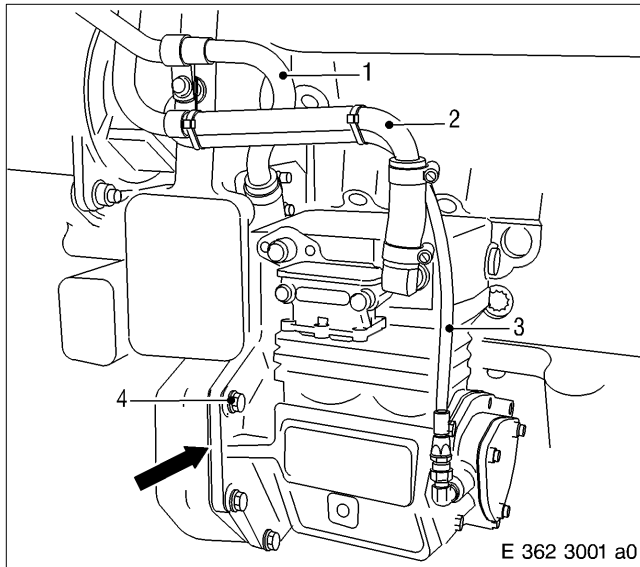

Installing air compressor

Note: Prior to installation, remove cover.
Make sure that oil-retaining parts are perfectly clean.

Check sealing surface fit in gear case and clean as necessary.

Fit gasket (arrow) via stud on gear case.

! WARNING

**Heavy object.
Risk of injury!
Use suitable tools and lifting equipment.**

Insert air compressor into register bore in gear case, ensuring that gear engages.

Insert securing screws (4) and nut and tighten diagonally and evenly.

Install coolant lines (1), (2) and oil line (3).

Note: After engine start, visually inspect coolant lines, compressed air lines and oil line for leaks; tighten as necessary.

C 362.40.12 After-Installation Operations

A distinction must be made as to whether:

- 1 ————— The engine is to be completely disassembled
- 2 ————— The engine is to be removed but not disassembled
- 3 ————— The engine is to remain installed

1	2	3	Operations	See
x	—	—	Perform operations as per Assembly Plan	B 005
x	—	—	Install engine	B 007
—	x	x	Install compressed air line	—
—	—	x	Fill engine coolant system	Operating Instructions
—	—	x	Release engine start	Operating Instructions



C 500 Monitoring, Control and Regulation Devices

See Special Publication

