

Technical Publication

mit / with

***REPAIR-Werkzeugen /
Tools***

Dieselmotor / Diesel Engine

Baureihe 2000

Series 2000

Werkzeugkatalog / Tool Catalogue

M004028/34DE

Ausgabe / Edition

19. Jan. 06 / 19 January 2006



Vorbemerkung / Preface

Dieser Werkzeugkatalog beinhaltet Werkzeuge und Vorrichtungen die zur Durchführung von Wartungs- und Montagearbeiten benötigt werden.

Aufbau des Werkzeugkataloges

Der Inhalt ist in folgende Rubriken gegliedert:

- allgemeines Werkzeug
- Qualifizierungslevelabhängiges Werkzeug
- Werkstatteinrichtung
- Messwerkzeuge

Innerhalb dieser Rubriken erfolgt die Sortierung der Werkzeuge nach Konstruktionsgruppen.

Eine Übersicht der Konstruktionsgruppen finden Sie auf den nachfolgenden Seiten.

- Werkzeuge für deren richtigen Gebrauch weiteres Werkzeug benötigt wird, haben den Vermerk "dazu" oder "zusätzlich zu besteht aus" und vor den nachfolgenden Sach-Nummern ein Plus-Zeichen (+).
- Werkzeugsätze die aus mehreren Sach-Nummern bestehen haben den Vermerk "besteht aus" und vor den nachfolgenden Sach-Nummern einen Pfeil ► oder zwei Pfeile ►►
- Ersatzteile für bestimmte Werkzeuge sind grau markiert und in der Spalte OZ zusätzlich mit entsprechenden Ortskennzahlen gekennzeichnet.

Hinweis: die bildliche Darstellung der Werkzeuge kann geringfügig abweichen.

Bei einer Werkzeugbestellung sind unbedingt anzugeben:

Motortyp Benennung Sach-Nr.

Motor Nr. Auftrags-Nr.

Werkzeugkatalog-Nr. Anzahl

Um Übermittlungsfehler zu vermeiden, bitten wir, telefonische Bestellungen schriftlich zu bestätigen.

This tool catalog contains the tools, jigs and fixtures required for engine maintenance and (dis)assembly work.

Tool catalog layout:

The contents are subdivided as follows:

- General tools
- Tools for specific qualification levels
- Workshop equipment
- Measuring equipment

Within these subdivisions, the tool-list sequence follows the engine design groups.

The design-group summary is on the following pages.

- Tools requiring supplementary tools for their correct use have the remarks "plus" or "in addition to/consists of", and are marked with a plus sign (+) before the following Part No.
- Tool kits consisting of several parts numbers have the remark "consists of" and are marked with either one (►) or two (►►) arrows before the following Part No.
- Spares for certain tools are indicated on a gray background and identified by callout numbers in the OZ column.

NOTE: the actual tools can differ slightly from those illustrated.

Please provide the following information when ordering:

Engine Modell Designation Part Number

Engine No MTU works order No.

Tool Catalogue No Quantity

To prevent errors, we request that phone orders be confirmed in writing.

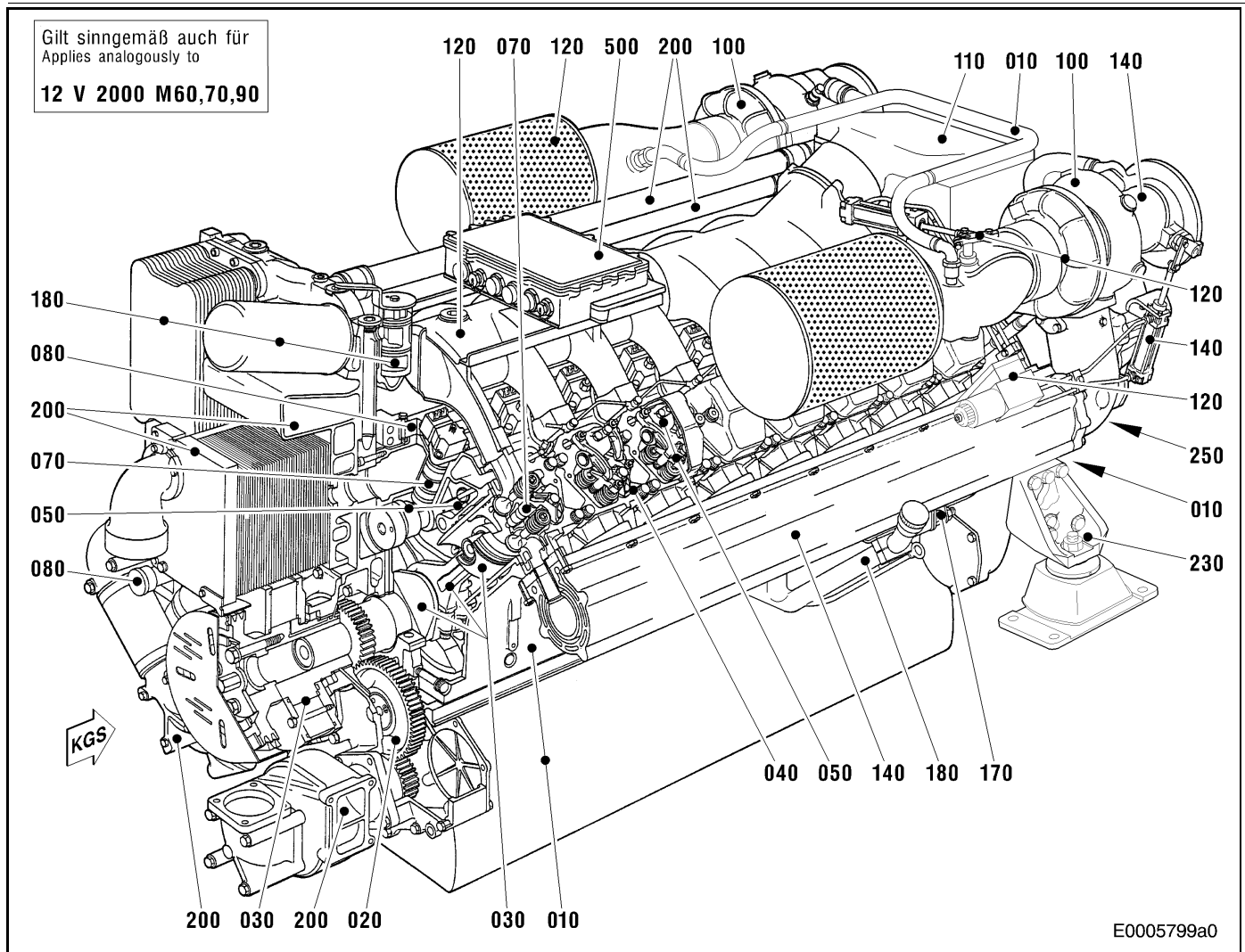



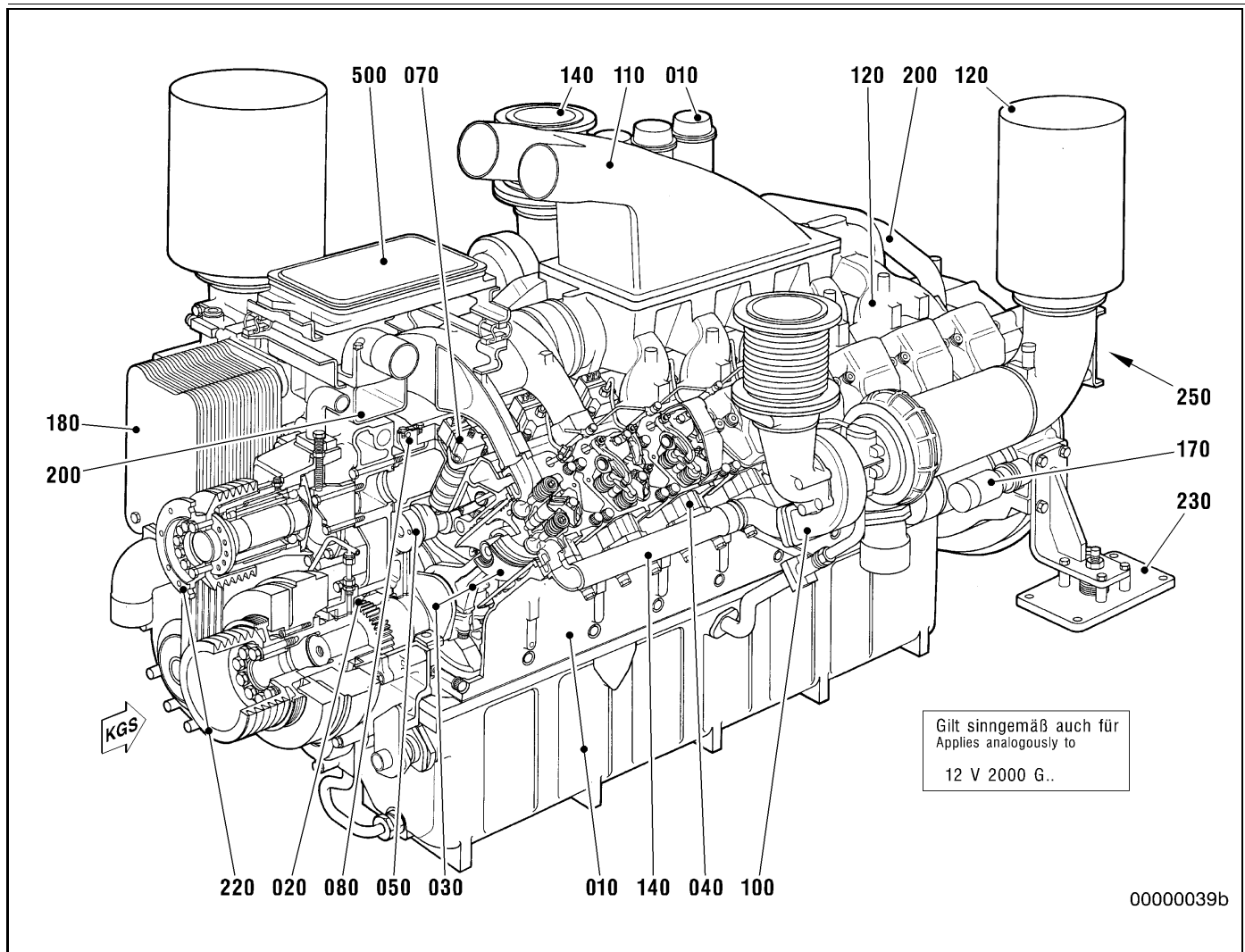





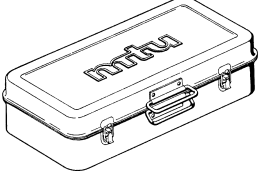



- | | |
|---|---|
| 010 Motorgehäuse und Anbauteile
Crankcase and attachments | 200 Kühlwassersystem
Coolant system |
| 020 Rädertrieb
Gear train, belt drive | 210 Stromversorgung (motorseitig)
Electric power supply, engine-related |
| 030 Triebwerk
Running gear | 220 Kühlluftsystem
Cooling air-system |
| 040 Zylinderkopf
Cylinder head | 230 Lagerung
Mounting system |
| 050 Steuerung
Valve gear | 250 Abtriebssysteme KS und KGS
Main and auxiliary PTO systems (couplings) |
| 070 Kraftstoffsystem (Hochdruck)
HP fuel system | 365 Abgassystem*
Exhaust system |
| 080 Kraftstoffsystem (Niederdruck)
LP fuel system | 368 Fremdwasser- Ver- und Entsorgungssystem*
Raw-water supply system |
| 100 Abgasturbolader
Turbochargers | 500 Überwachungs-, Steuerungs- und Regeleinrichtung
Monitoring and control system |
| 110 Ladeluftkühlung
Charge-air cooling | |
| 120 Luftansaugung/Luftzuführung
Air induction / air ducting | |
| 140 Abgasführung
Exhaust system | |
| 170 Anlasseinrichtung
Starting equipment | |
| 180 Motorenölkreislauf
Lubricating oil system | |















- | | |
|---|---|
| 010 Motorgehäuse und Anbauteile
Crankcase and attachments | 200 Kühlwassersystem
Coolant system |
| 020 Rädertrieb
Gear train, belt drive | 210 Stromversorgung (motorseitig)
Electric power supply, engine-related |
| 030 Triebwerk
Running gear | 220 Kühlluftsystem
Cooling air-system |
| 040 Zylinderkopf
Cylinder head | 230 Lagerung
Mounting system |
| 050 Steuerung
Valve gear | 250 Abtriebssysteme KS und KGS
Main and auxiliary PTO systems (couplings) |
| 070 Kraftstoffsystem (Hochdruck)
HP fuel system | 365 Abgassystem*
Exhaust system |
| 080 Kraftstoffsystem (Niederdruck)
LP fuel system | 368 Fremdwasser- Ver- und Entsorgungssystem*
Raw-water supply system |
| 100 Abgasturbolader
Turbochargers | 500 Überwachungs-, Steuerungs- und Regeleinrichtung
Monitoring and control system |
| 110 Ladeluftkühlung
Charge-air cooling | |
| 120 Luftansaugung/Luftzuführung
Air induction / air ducting | |
| 140 Abgasführung
Exhaust system | |
| 170 Anlasseinrichtung
Starting equipment | |
| 180 Motorenölkreislauf
Lubricating oil system | |







Oz	Sach-Nr. Part Number	Benennung Designation	Stück Qty	Verwendung / Used for Abmessung / Size	Seite/Page 5 von/of 109
	560 589 20 99/00	PRUEFKOFFER TEST KIT	1	zum Überprüfen von Kühlwasser und Motorenöl To check coolant and engine oil.	







Oz	Sach-Nr. Part Number	Benennung Designation	Stück Qty	Verwendung / Used for Abmessung / Size	Seite/Page 6 von/of 109
	820 589 11 59/00	WERKZEUGSATZ ALLGEM. GENERAL TOOL SET <i>besteht aus / consists of</i> ▶	1		
	▶ 000 589 38 37/00	WASSERPUMPENZANGE WATER PUMP PLIERS 24	1	240 mm 240 mm	
	▶ 000837 020000	SCHLUESSEL DOUBLE BOX SPANNER	1	SW 20 X 22 20 X 22mm A/F	
	▶ 001041 500001	HAMMER HAMMER	1	500 g 500 g	
	▶ 003110 006001	SCHLUESSEL OPEN END SPANNER	1	SW 6 X 7 6X7mm A/F	
	▶ 003110 008002	SCHLUESSEL OPEN END SPANNER	1	SW 8 X 10 8X10 A/F	

Oz	Sach-Nr. Part Number	Benennung Designation	Stück Qty	Verwendung / Used for Abmessung / Size	Seite/Page 7 von/of 109
	► 003110 017000	SCHLUESSEL OPEN END SPANNER	1	SW 17 X 19 17X19 A/F	
	► 003110 020000	SCHLUESSEL OPEN END SPANNER	1	SW 20 X 22 20X22 A/F	
	► 003110 024001	SCHLUESSEL OPEN END SPANNER	1	SW 24 X 27 24X27 A/F	
	► 003110 030001	SCHLUESSEL OPEN END SPANNER	1	SW 30 X 32 30X32 A/F	
	► 003110 036000	SCHLUESSEL WRENCH	1	SW 36 X 41 36X41 A/F	
	► 005238 160200	SEITENSCHNEIDER DIAGO CUTTING PLIERS	1	160 mm 160 mm	



Oz	Sach-Nr. Part Number	Benennung Designation	Stück Qty	Verwendung / Used for Abmessung / Size	Seite/Page 8 von/of 109
	► 005248 160100	ZANGE FLAT-NOSE PLIERS	1	160 mm 160 mm	
	► 005265 000151	SCHRAUBENDREHER SCREWDRIVER	1	0,5 X 3 X 75 mm 0.5x3x75mm	
	► 005265 000180	SCHRAUBENDREHER SCREWDRIVER	1	0,8 X 5,5 X 125 mm 0.8x5.5x125mm	
	► 005265 001100	SCHRAUBENDREHER SCREWDRIVER	1	1,0 X 7 X 150 mm 1.0x7x150mm	
	► 006450 003300	SPLINTTREIBER SPLIT PIN DRIVER 3MM	1	3 mm 3 mm	
	► 006458 005200	DURCHTREIBER DRIFT PUNCH	1	5 mm 5 mm	





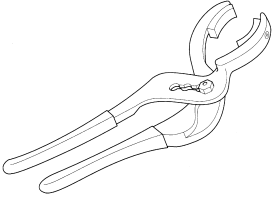

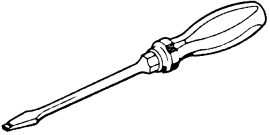
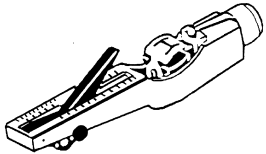
Oz	Sach-Nr. Part Number	Benennung Designation	Stück Qty	Verwendung / Used for Abmessung / Size	Seite/Page 9 von/of 109
	► 007250 005000	KOERNER CENTRE PUNCH	1	120 mm 120 mm	
	► 008350 160100	FLACHSCHABER FLAT SCRAPER	1	160 mm 160 mm	
	► 008350 160300	DREIKANT HOHLSCHABER TRIANGULAR SCRAPER	1	160 mm 160 mm	
	► 561 589 01 23/00	SCHILD LABEL	1	200 mm Deutsch / Englisch 200 mm German / Englisch	
	► 820 589 31 61/00	PLASTIKHAMMER PLASTIC MALLET	1	35 mm 35 mm	
	► 820 589 32 61/00	ABZIEHSTEIN OIL STONE	1	125 X 50 X 20 mm 125 X 50 X 20 mm	

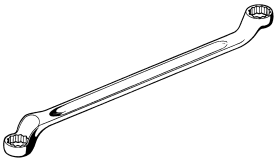

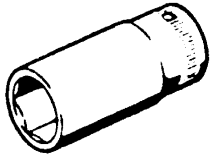

Oz	Sach-Nr. Part Number	Benennung Designation	Stück Qty	Verwendung / Used for Abmessung / Size	Seite/Page 10 von/of 109
	► F3 0002 770	DOPPELMAULSCHLUESSEL DBL OPEN END SPANN 1	1	SW 10 X 11 10x11mm A/F	
	► F3 0002 778	DOPPELMAULSCHLUESSEL DBL OPEN END SPANN 2	1	SW 22 X 24 22x24mm A/F	
	► F3 0004 451	DOPPELMAULSCHLUESSEL DBL OPEN END SPANN 1	1	SW 13 X 15 13x15mm A/F	
	► F3 0004 459	DOPPELRINGSCHLUESSEL DOUBLE BOX SPANNER	1	SW 8 X 9 8x9mm A/F	
	► F3 0004 461	DOPPELRINGSCHLUESSEL DOUBLE BOX SPANNER	1	SW 10 X 11 10x11mm A/F	
	► F3 0004 462	DOPPELRINGSCHLUESSEL BOX WRENCH	1	SW 12 X 13 12x13mm A/F	





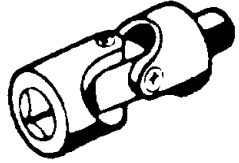

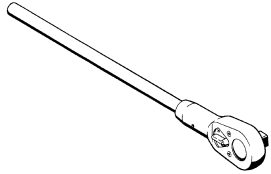
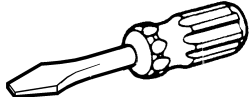
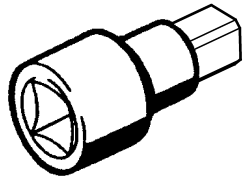
Oz	Sach-Nr. Part Number	Benennung Designation	Stück Qty	Verwendung / Used for Abmessung / Size	Seite/Page 11 von/of 109
	► F3 0004 463	DOPPELRINGSCHLUESSEL BOX WRENCH	1	SW 13 X 15 13x15mm A/F	
	► F3 0004 469	DOPPELRINGSCHLUESSEL BOX WRENCH	1	SW 24 X 27 24x27mm A/F	
	► F3 0004 471	DOPPELRINGSCHLUESSEL WRENCH, RING	1	SW 30 X 32 30x32mm A/F	
	► F3 0005 995	DOPPELMAULSCHLUESSEL OPEN-END WRENCH	1	SW 13 X 14 13x14mm A/F	
	► F3 0017 007	DOPPELRINGSCHLUESSEL DOUBLE BOX SPANNER	1	SW 16 X 17 16x17mm A/F	
	► F3 0017 009	DOPPELRINGSCHLUESSEL DOUBLE BOX SPANNER	1	SW 18 X 19 18x19mm A/F	







Oz	Sach-Nr. Part Number	Benennung Designation	Stück Qty	Verwendung / Used for Abmessung / Size	Seite/Page 12 von/of 109
	013 531 54 83	ZANGE PLIERS	1 E	für Bajonettsteckverbinder wie Sensoren, Magnetventile, Stellglieder etc. for bayonet connectors such as sensors, solenoid valves, actuators etc.	



Oz	Sach-Nr. Part Number	Benennung Designation	Stück Qty	Verwendung / Used for Abmessung / Size	Seite/Page 13 von/of 109
	F3 0378 864	WERKZEUGSATZ TOOL SET <i>besteht aus / consists of</i> ▶	1		
	▶ 005265 001420	SCHRAUBENDREHER SCREWDRIVER	1	1,2x6,5x150mm 1.2x6.5x150mm	
	▶ 550 589 01 19/00	RIEMENSPIANN.PRUEFER V-BELT TENSION GAUGE	1	Meßgerät für Keilriemenspannung 150 - 700 N measuring unit for testing vee-belt tension; 150-700 N	
	▶ 820 589 28 61/08	DORN MANDREL	1	zum lösen der Haltestifte to release extension segments	
	▶ 820 589 29 61/00	MAGNETSUCHER MAGNET LIFTER	1	biegsam with flexible shaft	
	▶ F3 0002 799	DOPPELRINGSCHLUESSEL DOUBLE BOX SPANNER 1	1	gekröpft, SW 14x17mm 14x17mm A/F	

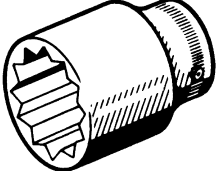



Oz	Sach-Nr. Part Number	Benennung Designation	Stück Qty	Verwendung / Used for Abmessung / Size	Seite/Page 14 von/of 109
	► F3 0004 939	STECKSCHLUESSELEINS. WRENCH SOCKET	1	SW 13, 1/2" 13 A/F, 1/2" sq.	
	► F3 0004 976	STECKSCHLUESSELEINS. WRENCH SOCKET	1	SW 27, 3/4" Vierk. 27 A/F, 3/4" sq.	
	► F3 0004 977	STECKSCHLUESSELEINS. SOCKET ADAPTER	1	SW 30, 3/4", lang 30 A/F, 3/4" sq., long	
	► F3 0005 655	DOPPELRINGSCHLUESSEL BOX WRENCH	1	gerade, SW 32x36mm straight, 32x36mm A/F	
	► F3 0006 125	STECKSCHLUESSELEINS. SOCKET 32 MM A F	1	SW 32, 3/4" 32 A/F, 3/4" sq.	
	► F3 0006 193	STARTERSCHLUESSEL STARTER KEY	1	SW 19x22mm 19x22mm A/F	

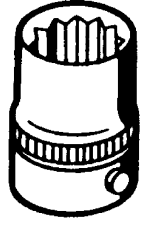

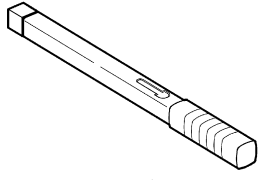
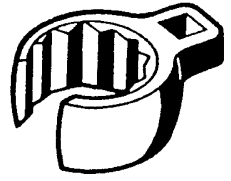
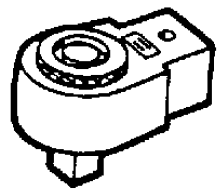
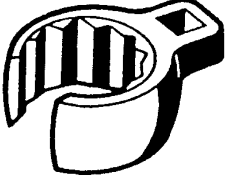
Oz	Sach-Nr. Part Number	Benennung Designation	Stück Qty	Verwendung / Used for Abmessung / Size	Seite/Page 15 von/of 109
	► F3 0006 202	KARDANGELENK UNIVERSAL JOINT	1	1/2" 1/2" sq.	
	► F3 0006 211	KNARRE RATCHET	1	1/2" 1/2" sq.	
	► F3 0006 212	KNARRENKOPF MIT VERL RATCHETWITH HANDLE	1	3/4" mit Verlängerung 3/4" sq., with extension	
	► F3 0006 227	SCHRAUBENDREHER SCREWDRIVER, SHORT	1	kurz short	
	► F3 0006 234	UEBERGANGSTEIL ADAPTER J1/2XA3/8	1	3/8" AVKT, 1/2" IVKT, 3/8"x1/2"	
	► F3 0006 235	UEBERGANGSTEIL ADAPTOR	1	innen 1/2", aussen 3/4" 1/2" inside 3/4" outside	

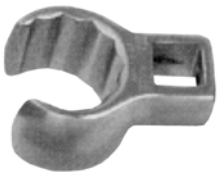
Oz	Sach-Nr. Part Number	Benennung Designation	Stück Qty	Verwendung / Used for Abmessung / Size	Seite/Page 16 von/of 109
	► F3 0011 450	OFF.DOPPELRINGSCHL. WRENCH, RING DE O/SE	1	SW17x19 offen für Einspritzleitung 17x19mm A/F Open, for injection lines	
	► F3 0011 580	SCHRAUBENDREHEREINS. INHEX INSERT SW-6	1	1/2" SW6 f. Innensechskant 1/2", 6 A/F	
	► F3 0011 584	SCHRAUBENDREHEREINS. INHEX INSERT SW-8	1	1/2" SW8 f. Innensechskant 1/2", 8 A/F	
	► F3 0011 587	SCHRAUBENDREHEREINS. INHEX INSERT 10 AF	1	1/2" SW10 f. Innensechskant 1/2", 10 A/F	
	► F3 0011 589	SCHRAUBENDREHEREINS. SCREWDRIVER BIT	1	1/2" SW12 f. Innensechskant 1/2", 12 A/F	
	► F3 0011 604	STECKSCHLUESSELEINS. SOCKET 10MM AF	1	1/2" SW 10 10 A/F, 1/2" sq.	

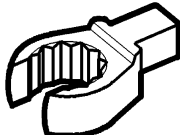
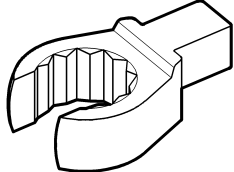

Oz	Sach-Nr. Part Number	Benennung Designation	Stück Qty	Verwendung / Used for Abmessung / Size	Seite/Page 17 von/of 109
	► F3 0011 607	STECKSCHLUESSELEINS. SOCKET 12MM AF	1	½" SW 12 12 A/F, ½" sq.	
	► F3 0011 616	STECKSCHLUESSELEINS. SOCKET 14 MM AF	1	½" SW 14 14 A/F, ½" sq.	
	► F3 0011 619	STECKSCHLUESSELEINS. SOCKET ADAPTER	1	SW 16 A/F 16mm	
	► F3 0011 621	STECKSCHLUESSELEINS. SOCKET 17 MM A F	1	½" SW 17 17 A/F, ½" sq.	
	► F3 0011 628	STECKSCHLUESSELEINS. SOCKET 19 MM AF	1	½" SW 19 19 A/F, ½" sq.	
	► F3 0011 636	STECKSCHLUESSELEINS. SOCKET	1	1/2" SW 22 22 A/F, ½" sq.	

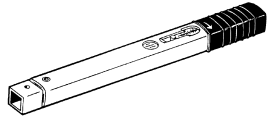
Oz	Sach-Nr. Part Number	Benennung Designation	Stück Qty	Verwendung / Used for Abmessung / Size	Seite/Page 18 von/of 109
	► F3 0011 639	STECKSCHLUESSELEINS. SOCKET 24 MM AF	1	½" SW 24 24 A/F, ½" sq.	
	► F3 0025 897	EINSTECKGABELSCHLUES OJ ADAPTER	1	Einsteck-Maulschlüssel SW19 zum Anziehen der Einspritzleitung am Zylinderkopf Plug in open end wrench (19 A/F) for tightening injection line on cylinder head	
	► F3 0026 582	DREHMOMENTSCHLUESSEL TORQUE METER	1	20 - 100 Nm, 9 x12 zum Anziehen der Einspritzleitungen 20-100 Nm, 9x12 for tightening injection lines	
	► F3 0026 816	HAHNENFUSS-RINGSCHL. SPIDER PATCH SPANNER	1	½", SW 32mm, offen ½", 32mm A/F, open	
	► F3 0027 340	EINSTECKKNARRE RATCHET ADAPTER	1	1/2" 9X12 Vierkant 1/2" sq., 9x12	
	► F3 0027 424	HAHNENFUSS-RINGSCHL. SPIDER PATCH SPANNER	1	SW 19, 3/8" Vierk. 19 A/F, 3/8" sq.	

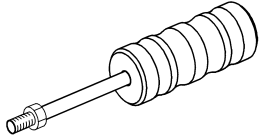
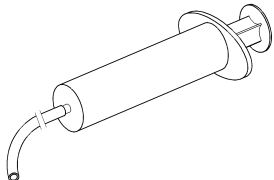
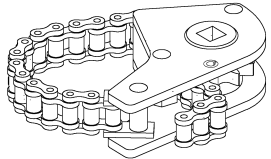
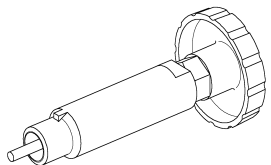
Oz	Sach-Nr. Part Number	Benennung Designation	Stück Qty	Verwendung / Used for Abmessung / Size	Seite/Page 19 von/of 109
	► F3 0027 425	HAHNENFUSS-RINGSCHL. SPIDER PATCH SPANNER	1	SW 22, 3/8" Vierkant für Kraftstoffleitung 22 A/F, 3/8" sq. for fuel line	
	► F3 0030 450	EINSTECKRINGSCHLUES. BOX WRENCH INSERT	1	SW 17 für Ventilkipphebel 17mm for valve rocker arm	
	► F3 0033 099	SCHRAUBENDREHER SCREW DRIVER	1	TORX 30 f. Gehäuseentlüftung TORX 30 for crankcase ventilation	
	► F3 0038 493	EINSTECKRINGSCHLUES. BOX WRENCH	1	SW 19, 9x12 Vierkant Einsteck-Ringschlüssel für Drehmomentschlüssel Box-end wrench socket fir torque wrench, 19x12 mm sq	
	► F3 0038 494	EINSTECKRINGSCHLUES. BOX WRENCH	1	SW 22mm, 9x12 Vierk. 22mm A/F, 9x12 sq.	
	► F3 0039 534	EINSTECKRINGSCHLUES. BOX WRENCH INSERT	1	SW 14 für Ventilbrücke 14mm for valve bridge	

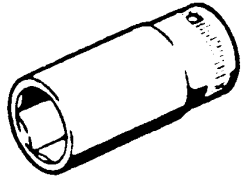
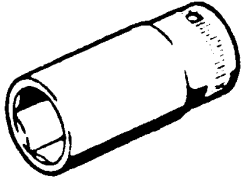
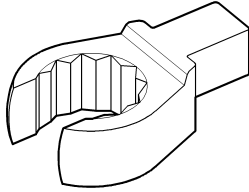
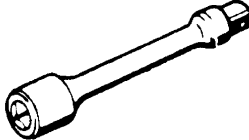
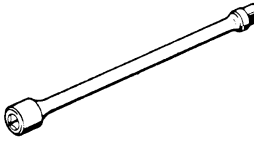
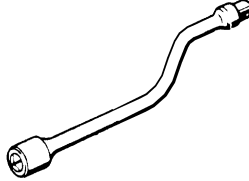
Oz	Sach-Nr. Part Number	Benennung Designation	Stück Qty	Verwendung / Used for Abmessung / Size	Seite/Page 20 von/of 109
	► F3 0043 446	DREHMOMENTSCHLUESSEL TORQUE WRENCH	1	8-40 Nm, 9x12 8-40 Nm, 9x12	
	► F3 0048 716	RINGMAULSCHLUESSEL COMBINATION WRENCH	1	SW 16, extra schmal für Ventilbrücke 16 A/f 16mm, extra thin for valve-bridge	
	► F3 0377 999	SCHLAG-AUSZIEHGERAET EXTRACTOR	1	M 8 für Düsenhalter und Druckrohrstutzen Percussion puller for injector, M8	
	► F3 0378 207	KRAFTSTOFFSAUGHEBER FUEL SUCTION DEVICE	1	für Kraftstoff Suction unit for fuel	
	► F3 0379 104	OELFILTERSCHLUESSEL OIL FILTER KEY	1	(auch f. Kraftstofffilter) Oil filter wrench, chain for oil and fuel filters	
	► F3 0379 151	SCHLITZMUTTERDREHER SLOTTED NUT DRIVER	1	für Kraftst.- Hochdruckleitung for H.P. fuel line	

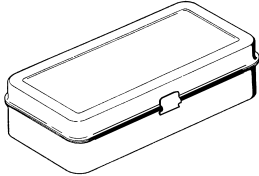

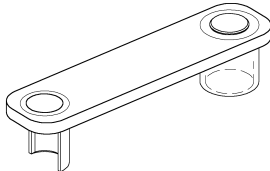
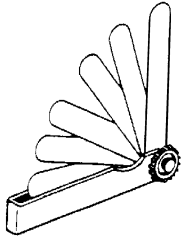
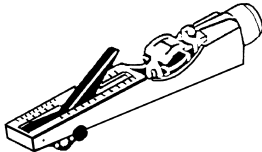
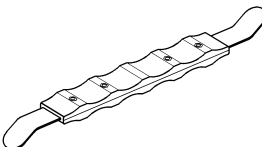
Oz	Sach-Nr. Part Number	Benennung Designation	Stück Qty	Verwendung / Used for Abmessung / Size	Seite/Page 21 von/of 109
	► F3 0500 943	STECKSCHLUESSELEINS. SOCKET	1	SW 10, ½" Vierk. 10 A/F, ½" sq.	
	► F3 0501 119	STECKSCHLUESSELEINS. SOCKET	1	SW 15, ½" Vierk. 15 A/F, ½" sq.	
	► F3 0501 562	EINSTECKRINGSCHLUES. BOX WRENCH	1	SW 24mm, 9x12 Vierk. 24mm A/F, 9x12 sq.	
	► F3 0501 567	VERLAENGER.SCHWENKB. EXTENSION, ROTATABLE	1	½" 125mm, kippbar ½", 125mm, swivel-type	
	► F3 0501 568	VERLAENGER.SCHWENKB. EXTENSION, ROTATABLE	1	½" 250mm, kippbar ½", 250mm, swivel-type	
	► F3 0501 569	VERLAENGER.GEKROEPFT EXTENSION, OFFSET	1	3/8" gebogen, f. Hahnenfussringschlüssel 3/8" sq. drive, bent, for crow-foot box-end wrench socket	

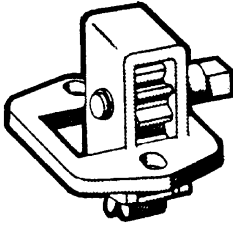
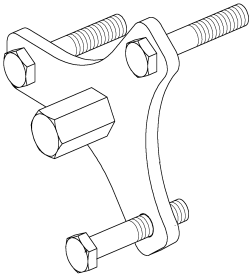
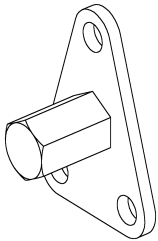
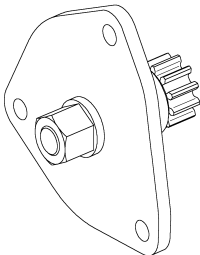
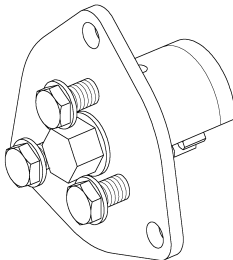

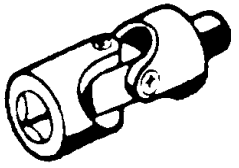
Oz	Sach-Nr. Part Number	Benennung Designation	Stück Qty	Verwendung / Used for Abmessung / Size	Seite/Page 22 von/of 109
	► F3 0501 919	STECKSCHLUESSELSATZ SOCKET WRENCH SET	1	1/4" 1/4" sq.	
	► F3 0508 223	RINGSCHLUESSEL BOX SPANNER	1	SW 30mm, kurz 30mm A/F, short	
	► F6 559 691	MONTAGEVORRICHTUNG ASSEMBLY FIXTURE	1	Montagevorr. f. Lima- Spannelement M00- Motoren Mounting jig for battery- generator securing element; M00 engines	
	► Y2 0010 128	BLATTSPION FEELER GAUGE	2	0,05-1,00 mm 0.05-1.00mm	
	► Y2 0097 429	VORSPANNMESSGERAET PRELOAD GAUGE	1	f. Rippenriemen Generator for generator ribbed belt	
	► Y4 342 013	ZB.LEHRE 0.4/0.6 GAUGE	1	für Ventilspieleinstellung for valve clearance 0.4/0.6 mm	

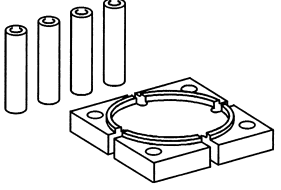
Oz	Sach-Nr. Part Number	Benennung Designation	Stück Qty	Verwendung / Used for Abmessung / Size	Seite/Page 23 von/of 109
	407 589 00 63/00	DREHVORRICHTUNG JIG	1	f. 8 V G00 Aggregatmotor for 8 V G00 genset engine	
	F6 557 971	DURCHDREHVORRICHTUNG BARRING TOOL	1	f. 12V-C&I Motor Dazu: Steckschl.-Einsatz SW 27 F3 0004 976 u. Knarre 3/4" F3 0006 212 for 12V C&I Engine plus: Wrench Socket 27 A/F F3 0004 976 and Ratchet 3/4" F3 0006 212	
	F6 558 531	DURCHDREHVORRICHTUNG BARRING TOOL	1	f. 16V-C&I-Motor Dazu Steckschl.-Einsatz SW 32 F3 0006 125 u. Knarre 3/4" F3 0006 212 for 16V C&I engine plus: Wrench Socket 32 A/F F3 0006 125 and Ratchet 3/4" F3 0006 212	
	F6 558 556	DURCHDREHVORRICHTUNG BARRING TOOL	1	f. 12 V G02 Aggregatmotor Dazu: Steckschl.-Einsatz SW 30 F3 0004 977 u. Knarre 3/4" F3 0006 212 for 12 V G02 genset engine plus: Wrench Socket 30 A/F F3 0004 977 and Ratchet 3/4" F3 0006 212	
	F6 558 557	DURCHDREHVORRICHTUNG BARRING TOOL	1	f. 16/18 V G02 Aggregatmotor Dazu: Steckschl.-Einsatz SW 30 F3 0004 977 u. Knarre 3/4" F3 0006 212 for 16/18 V G02 genset engine plus: Wrench Socket 30 A/F F3 0004 977 and Ratchet 3/4" F3 0006 212	

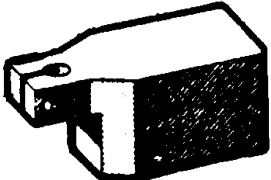
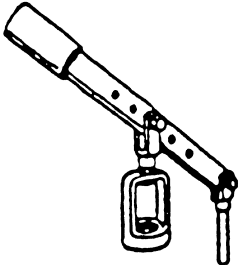

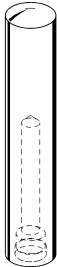
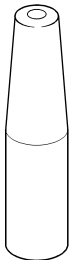
Oz	Sach-Nr. Part Number	Benennung Designation	Stück Qty	Verwendung / Used for Abmessung / Size	Seite/Page 24 von/of 109
	F3 0006 203	KARDANGELENK UNIVERSAL JOINT	1	3/4" 3/4"	

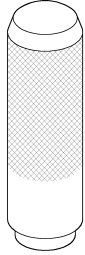

Oz	Sach-Nr. Part Number	Benennung Designation	Stück Qty	Verwendung / Used for Abmessung / Size	Seite/Page 25 von/of 109
	541 589 00 21/00	MESSPLATTE SURFACE PLATE	1	Messplatte für Laufbuchsenüberstand Measuring plate for cylinder line protrusion	

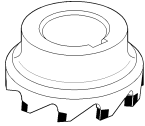
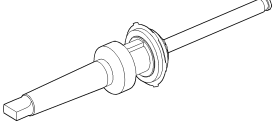
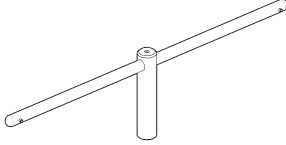
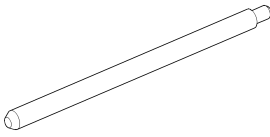

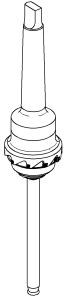
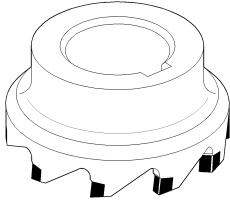
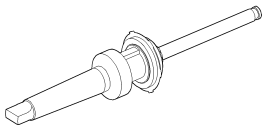
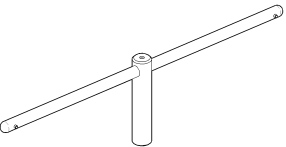

Oz	Sach-Nr. Part Number	Benennung Designation	Stück Qty	Verwendung / Used for Abmessung / Size	Seite/Page 26 von/of 109
	000 589 18 53/00	REIBAHLE REAMER	1 R	Ventilführungsbohrung im Zylinderkopf nachreiben, ø 13,5 - 15,5mm to re-ream valve-guide bore in cylinder head ø 13.5 - 15.5mm	
	343 589 00 40/00	HALTER BRACKET	1 R	Meßuhrhalter Dial gauge holder	
	442 589 00 31/00	VENTILHEBER VALVE COMPRESSOR	1		
	F3 0377 657	STECKSCHLUESSELEINS. SOCKET	1	für Schutzhülse Zylinderkopf for cylinder head protective sleeve	
	F3 0377 883	EINSCHLAGDORN DRIFT	1	für Ventilschaftabdichtung for valve stem seal	
	F3 0377 930	EINSPREIZWERKZEUG EXPANDER	1	für Ventilschaftabdichtung Spreader for valve stem seal	

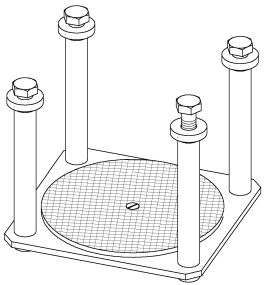

Oz	Sach-Nr. Part Number	Benennung Designation	Stück Qty	Verwendung / Used for Abmessung / Size	Seite/Page 27 von/of 109
	F3 0378 878	EINSCHLAGDORN DRIFT	1 R	für Verschußdeckel 326 997 10 20 im Zyl.-Kopf for end cover 326 997 10 20 in cyl. Head	
	F3 0378 880	EINSETZDORN INSTALLATION MANDREL	1 R	f. Ventilsitzring 541 053 16 31 Einlass for valve seat insert 541 053 16 31 inlet	
	F3 0378 881	EINSETZDORN INSTALLATION MANDREL	1 R	f. Ventilsitzring 541 053 04 32 Auslass for valve seat insert 541 053 04 32 exhaust	

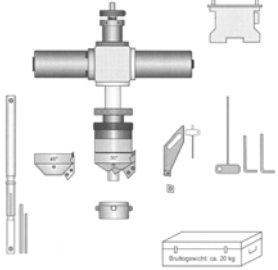
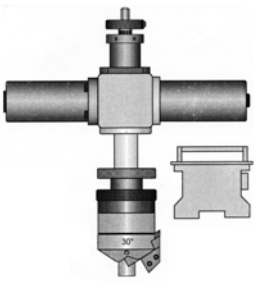

Oz	Sach-Nr. Part Number	Benennung Designation	Stück Qty	Verwendung / Used for Abmessung / Size	Seite/Page 28 von/of 109
	F3 0378 896	VENTILSITZFREISENKER VALVE SEAT GRINDER <i>besteht aus / consists of</i> ▶	1 R	für Auslassventil for exhaust valve	
	▶ F3 0378 897	VENTILSITZFREISENKER VALVE-SEAT CONTOUR REST	1	Auslassventil Ventilsitzring nacharbeiten for reworking outlet valve- seat ring	
	▶ F7 0270 439	AUFSTECKHALTER DETACHABLE HOLDER	1	für Freisenker mit Führung 9mm ø und Kegelschaft MK-B2 for contour restoring tool with guide 9 mm ø and MK-B2 taper shank	
	+ 820 589 04 51/00	DREHGRIFF TURNING HANDLE <i>zusätzlich zu besteht aus / plus consists of</i>	1	MK2 MK2	 <small>8205890451a</small>
	F3 0450 454	AUSSCHLAGWERKZEUG PUNCH	1 R	für Ventilfehrung, auch zum Eineisen for valve guide, also for chilling	

Oz	Sach-Nr. Part Number	Benennung Designation	Stück Qty	Verwendung / Used for Abmessung / Size	Seite/Page 29 von/of 109
	F3 0450 549	VENT-SITZFREISENKWKZ VALVE ST.CTRSK TOOL <i>besteht aus / consists of</i> ▶	1 R	Einlassventilsitz oberer Freigang nacharbeiten for reconditioning inlet valve seat, upper clearance	
	▶ F3 0450 550	VENTILSITZFREISENKER VALVE SEAT CTRSINK	1	Einlassventil Ventilsitzring nacharbeiten to rework inlet valve-seat insert	
	▶ F7 0271 788	AUFSTECKHALTER DETACHABLE HOLDER	1	für Freisenker mit Führung 9mm ø und Kegelschaft MK-B2 for contour restoring tool with guide 9 mm ø and MK-B2 taper shank	
	+ 820 589 04 51/00	DREHGRIFF TURNING HANDLE <i>zusätzlich zu besteht aus / plus consists of</i>	1	MK2 MK2	 8205890451a
	F3 0450 845	ZANGE PLIERS	1	zum Abziehen der Ventilschaftabdichtung for removal of valve stem seal	
	F3 0543 150	MASCHINENREIBAHLE MACHINE REAMER	1	ø 9,0 mm Ventilführung 5410531130 auf Fertigmass reiben ø 9.0 mm for reaming of valve guide 5410531130 to finished dimension	

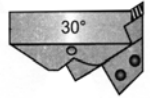
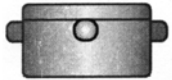
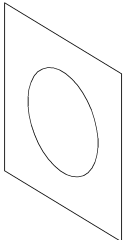
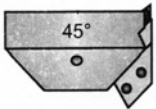
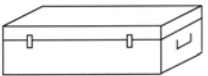



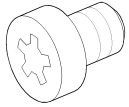

Oz	Sach-Nr. Part Number	Benennung Designation	Stück Qty	Verwendung / Used for Abmessung / Size	Seite/Page 30 von/of 109
	F3 0543 151	MASCHINENREIBAHLE MACHINE REAMER	1	<p>ø 8,8 mm Ventilführung 5410531130 vorreiben</p> <p>ø 8.8 mm for pre-reaming of valve guide 5410531130</p>	
	F3 0907 150	STECKSCHLUESSELEINS. SOCKET 19 MM AF	1	<p>SW 19, 3/4" Vierkt. für Zylinderkopfschrauben</p> <p>19mm, 3/4" square drive, for cylinder-head screws</p>	
	F6 554 686	ANHALTEVORRICHTUNG RETAINING FIXTURE	1	<p>Zylinderkopf, Ventile ausbauen</p> <p>to remove valves from cylinder head</p>	

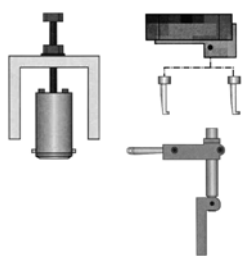
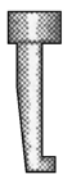
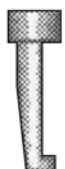
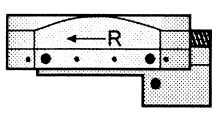
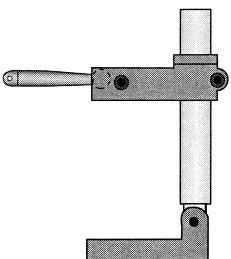
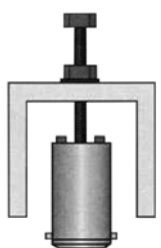

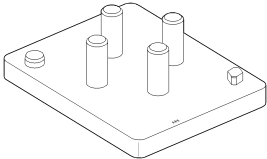



Oz	Sach-Nr. Part Number	Benennung Designation	Stück Qty	Verwendung / Used for Abmessung / Size	Seite/Page 31 von/of 109
	F6 783 844	ZB WERKZEUGSATZ TOOL KIT <i>besteht aus / consists of</i> ▶	1 R	Ventilsitz nacharbeiten for reworking valve seat	
	▶ F2 0005 101	VENTILSITZ-DREHMASCH VALVE SEAT GRINDING TOOL	1	VDS 2E VDS 2E	
	▶ F3 0002 814	WINKELSCHRAUBENDREH. SOCK HD SCREW SPANN	1	SW 4mm AF 4mm	
	▶ F3 0002 815	WINKELSCHRAUBENDREH. SOCK HD SCREW SPANN	1	Innensechskant, SW 5 Allen key, 5 A/F	
	▶ F3 0022 029	SCHRAUBENDREHER SCREW DRIVER	1	SW 3mm AF 3mm	
	▶ F3 0028 069	SCHRAUBENDREHER SCREWDRIVER	1	SW TX8 AF TX8	

Oz	Sach-Nr. Part Number	Benennung Designation	Stück Qty	Verwendung / Used for Abmessung / Size	Seite/Page 32 von/of 109
	► F3 0450 355	AUSDREHKOPF BORING HEAD	1	D2, 30° D2, 30°	
	► F3 0450 356	STUETZKREUZ SUPPORT	1	ø 32 - 42mm ø 32-42mm	
	► F3 0450 433	WENDESCHNEIDPLATTE INDEXABLE INSERT	5	für Drehgerät VDS2E zum Ventilsitze nacharbeiten for VDS2E turning device to recondition valve seats	
	► F3 0450 907	AUSDREHKOPF BORING HEAD	1	D2, 45° D2, 45°	
	► F6 783 737	WERKZEUGKASTEN TOOL BOX	1		
	► F6 783 846	SATZ ZUBEHOER SET OF ACCESSORIES	1	ø 9mm ø 9 mm	

Oz	Sach-Nr. Part Number	Benennung Designation	Stück Qty	Verwendung / Used for Abmessung / Size	Seite/Page 33 von/of 109
	► F7 0014 018	SCHRAUBE FUER WSP SCREW FOR INDEXABLE INS	1	für Wendeschneidplatte, M2,5X7mm, SW TX8 for indexable insert, M2.5X7mm, AF TX8	 <small>F70014018a</small>
	► F7 0272 180	KLEMMHALTER CLAMP	1	SD00 SD00	

Oz	Sach-Nr. Part Number	Benennung Designation	Stück Qty	Verwendung / Used for Abmessung / Size	Seite/Page 34 von/of 109
	F6 784 110	WERKZEUGSATZ TOOL KIT <i>besteht aus / consists of</i> ▶	1 R	zum Demontieren der Ventilsitzringe to remove valve-seat inserts	
	▶ F3 0450 557	DREHMEISSEL TURNING TOOL	5	für Auslass for exhaust	
	▶ F3 0450 558	DREHMEISSEL TURNING TOOL	5	für Einlass for inlet	
	▶ F3 0450 909	AUSDREHKOPF ADAPTER HEAD	1	D2/0° D2/0°	
	▶ F3 0450 910	LUENETTENHALTER STEADY HOLDER	1		
	▶ F3 0450 917	SITZRINGAUSZIEHER VALVE SEAT RING EXTRACT	1		

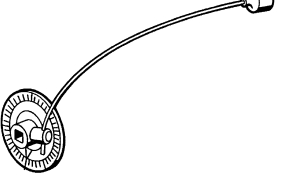



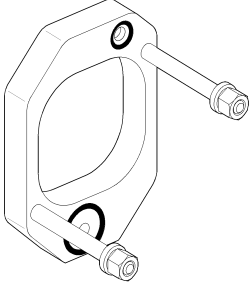
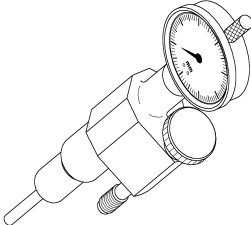
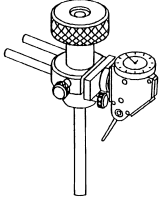
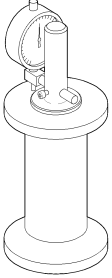
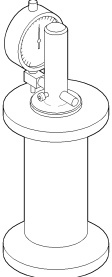

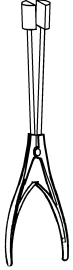
Oz	Sach-Nr. Part Number	Benennung Designation	Stück Qty	Verwendung / Used for Abmessung / Size	Seite/Page 35 von/of 109
	F6 784 237	MONTAGEPLATTE MOUNTING PLATE	1	für Ventilfehrungen eineisen for chilling of valve guides	
	F7 0000 073	REDUZIERHUELSE ADAPTOR SLEEVE	1	MK3/MK2 zum Aufnehmen des Pendelfutter in der Bohrmaschine MK3/MK2 for chuck in drilling machine	
	F7 0000 146	REDUZIERHUELSE REDUCTION SLEEVE	1	MK4/MK3 zum Aufnehmen der Verlängerungshülsen in der Bohrmaschine MK4/MK3 for extension sleeves in drilling machine	
	F7 0000 199	AUSTREIBER MANDREL	1	MK1/MK2 zum Ausbauen der Werkzeuge aus der Bohrmaschine MK1/MK2 for tool removal from drilling machine	
	F7 0000 200	AUSTREIBER MANDREL	1	MK3, zum Ausbauen der Werkzeuge aus der Bohrmaschine MK3, for tool removal from drilling machine	
	F7 0000 417	VERLAENGERUNGSHUELSE EXTENSION SLEEVE	1	MK3/MK3, für Zentrierspitze zum Ausrichten des Zylinderkopfes auf der Bohrmaschine MK3/MK3, for centering tip to align cylinder head with drilling machine	

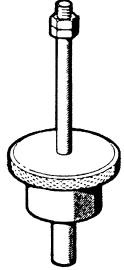
Oz	Sach-Nr. Part Number	Benennung Designation	Stück Qty	Verwendung / Used for Abmessung / Size	Seite/Page 36 von/of 109
	F7 0000 637	AUSTREIBER MANDREL	1	MK4, zum Ausbauen der Werkzeuge aus der Bohrmaschine MK4 for tool removal from drilling machine	
	F7 0000 966	ZENTRIERSPITZE CENTERING TIP	1	MK3, zum Ausrichten des Zylinderkopfes auf der Bohrmaschine MK3, for tool removal from drilling machine	
	F7 0001 021	REDUZIERHUELSE REDUCTION SLEEVE	1	MK4/MK2, zum Aufnehmen des Pendelfutter in der Bohrmaschine MK4/MK2 for chuck in drilling machine	
	F7 0007 011	PENDELHALTER FLYWEIGHT RETAINER	1	MK2 zum Einspannen der Reibahlen und Ausgleichen von Maschinentoleranzen MK2 for chucking reamers and machine tolerance compensation zum Einspannen der	
	Y2 0044 010	DREHWINKELMESSGERAET ANGULAR TORQUE JIG	1	für Zylinderkopfschrauben, 1/2" u. Wellenmutter KKK-Lader und AGL 175 / 195 For cyl.-head screws: 1/2" sq. drive with shaft nut, for KKK turbochargers	
	Y2 0098 136	GRENZLEHRDORN PLUG GAUGE	1 R	ø 9mm H8 für Ventilführung ø 9mm H8 for valve guide	

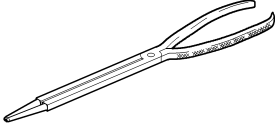

Oz	Sach-Nr. Part Number	Benennung Designation	Stück Qty	Verwendung / Used for Abmessung / Size	Seite/Page 37 von/of 109
	Y4 341 042	ABPRESSVORRICHTUNG PRESS TESTING DEVICE	1	für Zylinderkopf for cylinder head	
	Y4 341 106	MESSVORRICHTUNG MEASURING JIG	1	OT einstellen über Zylinderk. f. Aggregatmot. TDC adjustment over cylinder head for genset engines	
	Y4 341 935	PRUEFVORRICHTUNG TESTING DEVICE	1 R	für Rundlauf der Ventilsitze for runout of valve seats	
	Y4 346 861	LEHRE GAUGE	1	für Auslassventil und- Ventilsitz for exhaust valve and valve seat	
	Y4 346 862	LEHRE GAUGE	1	für Einlassventil und- Ventilsitz for inlet valve and valve seat	

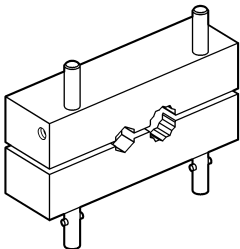
Oz	Sach-Nr. Part Number	Benennung Designation	Stück Qty	Verwendung / Used for Abmessung / Size	Seite/Page 38 von/of 109
	F3 0378 037	GREIFZANGE GRIPPING PLIERS	1	für Rollenstößel for roller tappet	

Oz	Sach-Nr. Part Number	Benennung Designation	Stück Qty	Verwendung / Used for Abmessung / Size	Seite/Page 39 von/of 109
	355 589 01 63/00	ABZIEHER PULLER	1	Schlagauszieher für E- Pumpe Ausbau Impact extractor for injection pump removal	

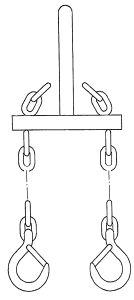
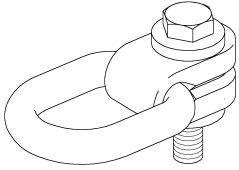
Oz	Sach-Nr. Part Number	Benennung Designation	Stück Qty	Verwendung / Used for Abmessung / Size	Seite/Page 40 von/of 109
	F3 0011 640	STECKSCHLUESSELEINS. SOCKET ADAPTER	1 R	Überholungs-WZ für KKK-Lader K42 und K44 SW 24, lang Overhaul tools for chargers K42 and K44, 24 A/F, long	
	F3 0028 341	MAULEINSTECKSCHLUESS OPEN-END WRENCH	1 R	Überholungs-WZ für KKK-Lader K42 und K44 SW 17, 9x12 Vierkant Overhaul tools for chargers K42 and K44, 17 A/F, 9x12 sq. Drive	
	F3 0376 601	ZANGEN F. SICH.RINGE CIRCLIPS PLIERS	1 R	Überholungs-WZ für KKK-Lader K36 bis K44 für S.-Ring der Lagerbuchse Overhaul tools for chargers K36 to K44, for bearing bush snap ring	
	F3 0520 703	DREHMOMENTSCHLUESSEL TORQUE METER	1 R	Überholungs-WZ für KKK-Lader K36 bis K44 und ZR 175 / ZR 195, doppelarmig. 10-90 NM Overhaul tools for chargers K36 to K44, and ZR 175 / ZR 195 two-armed. 10-90 NM	
	F7 0144 375	MONTAGEBACKEN VISE JAW	1 R	Überholungs-WZ für KKK-Lader K36 bis K44 für Schraubstock Overhaul tools for chargers K36 to K44, for vise	
	Y2 0504 961	DYNAMOMETER CALIBRATION UNIT	1 R	Überholungs-WZ für KKK-Lader K36 bis K44 (Federwaage) bis 100 N (spring balance) to 100 N	

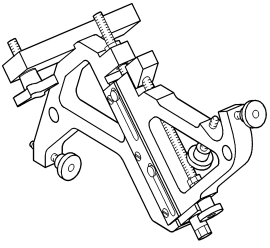

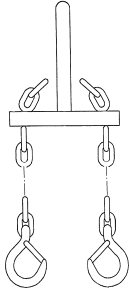
Oz	Sach-Nr. Part Number	Benennung Designation	Stück Qty	Verwendung / Used for Abmessung / Size	Seite/Page 41 von/of 109
	T8 0090 943	HAKENKETTE HOOK CHAIN <i>dazu / plus</i> +	1	f. Lufthutze mit L.- Luftrohre kompl. G02 Mot. for airscoop with air manifold, compl. G02 engine.	
	+ ► B80144961	LASTBOCK TRESTLE	2	M8 zur Hakenkette M8 load pedestal for hook- ended sling	

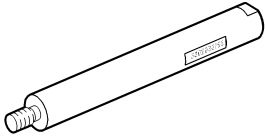
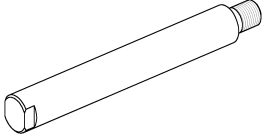
Oz	Sach-Nr. Part Number	Benennung Designation	Stück Qty	Verwendung / Used for Abmessung / Size	Seite/Page 42 von/of 109
	F6 554 717	ABSENKVERRICHTUNG JACKSCREW	2	Nur für gekühlte Abgasrohre only for coolant-cooled exhaust pipe	
	T8 0091 769	AUFHAENGEHAKEN LIFTING HOOK <i>dazu / plus</i> +	2	gekühltes Abgasführungsrohr an/abbauen for removal/installation of cooled exhaust pipe	
	+ T8 0090 943	HAKENKETTE HOOK CHAIN	1	f. Lufthutze mit L.- Luftrohre kompl. G02 Mot. for airscoop with air manifold, compl. G02 engine.	

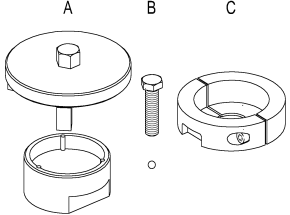
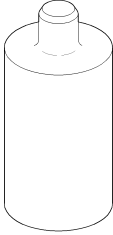
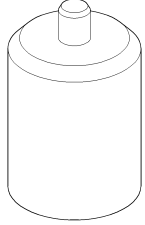
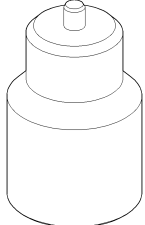
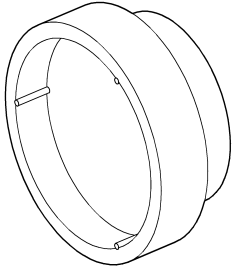
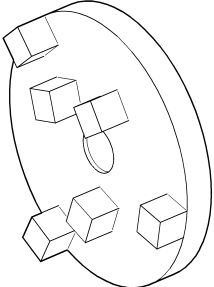
Oz	Sach-Nr. Part Number	Benennung Designation	Stück Qty	Verwendung / Used for Abmessung / Size	Seite/Page 43 von/of 109
	536 203 01 62	GEWINDEBOLZEN THREADED PIN	2	M16 f. Plattenkühler SEED-u.SILA-Mot. M16 guide pin for plate- type cooler, SEED + SILA engines	
	536 203 04 62	GEWINDEBOLZEN THREADED PIN	2	M20 f. Plattenkühler Serien-Mot. M20 guide pin for plate- type cooler, series engines	

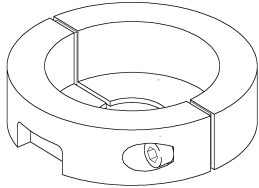
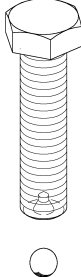
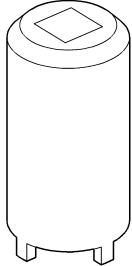
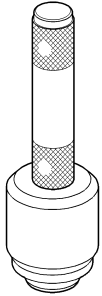
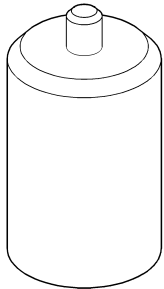
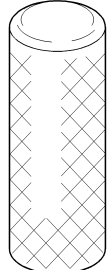
Oz	Sach-Nr. Part Number	Benennung Designation	Stück Qty	Verwendung / Used for Abmessung / Size	Seite/Page 44 von/of 109
	F0 140 601	WARTUNGSSATZ MAINTENANCE KIT <i>besteht aus / consists of</i> ▶	1	Für Seewasserpumpe 000 200 05 01 Tools for seawater pump 000 200 05 01	
	▶ F3 0450 464	AUSPRESSDORN EXTRACTION MANDREL	1	Gleitringdichtung aus-und einpressen for rotary seal removal/installation	
	▶ F3 0450 565	AUSPRESSDORN REMOVAL MANDEL	1	für Radialwellendichtring for radial-lip shaft seal	
	▶ F3 0450 566	AUSPRESSDORN REMOVAL MANDEL	1	für Zylinderrollenlager for cylindrical roller bearing	
	▶ F6 559 664	ADAPTER ADAPTER	1	für Zahnrad A für Prüfen des Haftmomentes for Gear A To check torque of impeller nut.	
	▶ F6 559 666	ADAPTER ADAPTER	1	für Laufrad B für Demontage des Laufrades for Impeller B for removal of impeller	

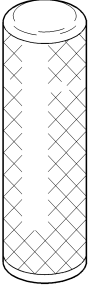
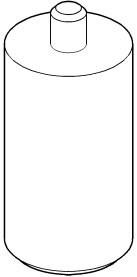
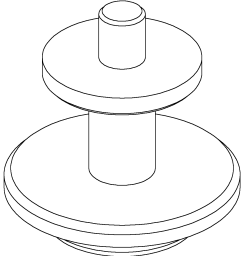
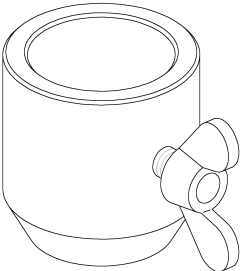

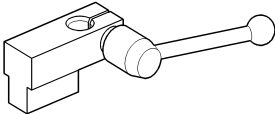

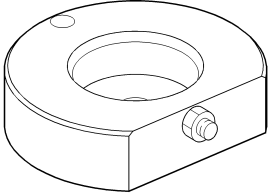
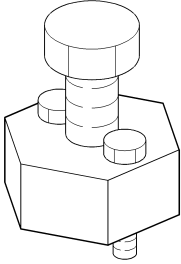
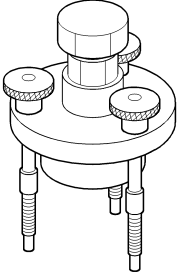
Oz	Sach-Nr. Part Number	Benennung Designation	Stück Qty	Verwendung / Used for Abmessung / Size	Seite/Page 45 von/of 109
	► F6 559 669	ABZIEHVORRICHTUNG WITHDRAWAL DEVICE	1	für Zahnrad C für Demontage des Zahnrades for Gear C for removal of gear	
	► F6 559 671	DRUCKSCHRAUBE THRUST SCREW	1	für Laufrad B für Demontage des Laufrades for impeller B for removal of impeller	
	F3 0378 028	SCHR.DREHER-EINSATZ ALLEN-TYPE ADAPTER	1 R	WZ für Wasserpumpe 536 200 07 01 (nur SILA u. SEED-Mot.) für Nutmutter Tools for coolant pump 536 200 07 01 (SILA + SEED engines only) for groove nut	
	F3 0378 069	EINDRUECKWERKZEUG FORCE-IN TOOL	1 R	WZ für Wasserpumpe 536 200 07 01 (nur SILA u. SEED-Mot.) f. Wellendichtring Tools for coolant pump 536 200 07 01 (SILA + SEED engines only) for shaft seal	
	F3 0378 070	EINDRUECKWERKZEUG FORCE-IN TOOL	1 R	WZ für Wasserpumpe 536 200 07 01 (nur SILA u. SEED-Mot.) Montage Welle u. Lager in Gehäuse Tools for coolant pump 536 200 07 01 (SILA + SEED engines only)installing shaft + bearing in housing	
	F3 0378 071	EINDRUECKWERKZEUG FORCE-IN TOOL	1 R	WZ für Wasserpumpe 536 200 07 01 (nur SILA u. SEED-Mot.) f. Gleitdichtring Tools for coolant pump 536 200 07 01 (SILA + SEED engines only) for slip ring seal	

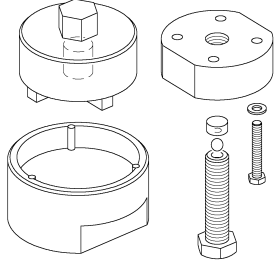
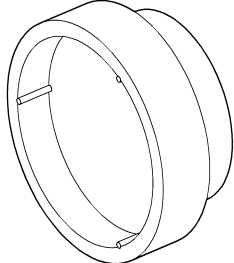
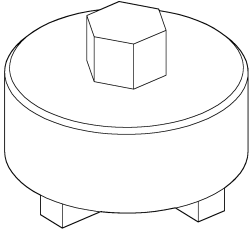
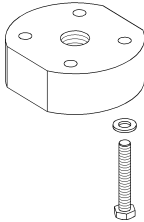
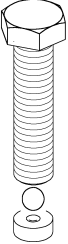
Oz	Sach-Nr. Part Number	Benennung Designation	Stück Qty	Verwendung / Used for Abmessung / Size	Seite/Page 46 von/of 109
	F3 0378 113	EINDRUECKWERKZEUG FORCE-IN TOOL	1 R	f. Anlaufring Wasserp. SEED-SILA-Motor for thrust ring water p. SEED-SILA engine	
	F3 0378 146	EINDRUECKWERKZEUG FORCE-IN TOOL	1 R	WZ für Wasserpumpe 536 200 07 01 (nur SILA u. SEED-Mot.) für Schrägkugellager u. Innenr. Zvl.-Rollenl. Tools for coolant pump 536 200 07 01 (SILA + SEED engines only) for angular-contact ball bearing + cvl. roller	
	F3 0378 550	EINPRESSWERKZEUG INSTALLATION TOOL <i>dazu / plus</i> +	1 R	für Wellendichtring, Frisch- Seewasserpumpe for shaft seal, coolant and seawater pump	
	+ F3 0275 611	AUFNAHME MOUNT	1	für Dornpresse for mandrel press	
	F3 0378 883	EINDRUECKWERKZEUG FORCE-IN TOOL	1 R	WZ für Wasserpumpe 536 200 13 01/ 536 200 14 01 für Serien-Motor f. Anlaufring von Tools for coolant pump 536 200 13 01/ 536 200 14 01 for series engine for thrust ring of slip ring seal	
	F6 554 722	ANHALTEVORRICHTUNG RETAINING FIXTURE	1 R	WZ für Wasserpumpe 536 200 07 01 (nur SILA u. SEED-Mot.) f. Welle z. Anziehen der Nutmutter Tools for coolant pump 536 200 07 01 (SILA + SEED engines only) for shaft for tightening grooved nut	

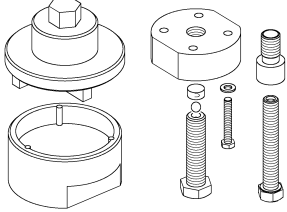
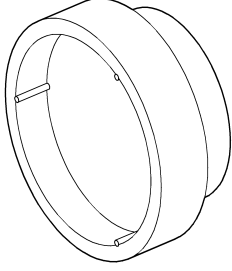
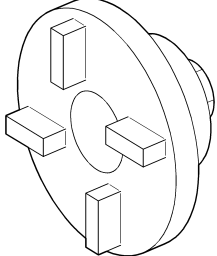
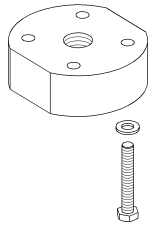
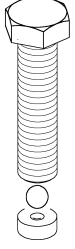
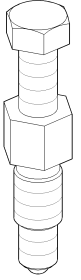
Oz	Sach-Nr. Part Number	Benennung Designation	Stück Qty	Verwendung / Used for Abmessung / Size	Seite/Page 47 von/of 109
	F6 554 724	ANHALTEVORRICHTUNG RETAINING FIXTURE	1 R	WZ für Wasserpumpe 536 200 07 01 (nur SILA u. SEED-Mot.) z. Anziehen der Laufmutter Tools for coolant pump 536 200 07 01 (SILA + SEED engines only) for tightening impeller nut	
	F6 555 702	MONTAGE-/ABZIEHVORR. INSTAL/REMOV JIG	1 R	WZ für Wasserpumpe 536 200 07 01 (nur SILA u. SEED-Mot.) f. Zahnrad Tools for coolant pump 536 200 07 01 (SILA + SEED engines only) for gear	
	F6 555 703	ABZIEHVORRICHTUNG EXTRACTING FIXTURE	1 R	WZ für Wasserpumpe 536 200 07 01 (nur SILA u. SEED-Mot.) f. Laufmutter Tools for coolant pump 536 200 07 01 (SILA + SEED engines only) for impeller	

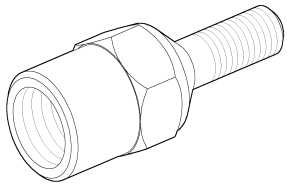
Oz	Sach-Nr. Part Number	Benennung Designation	Stück Qty	Verwendung / Used for Abmessung / Size	Seite/Page 48 von/of 109
	F6 559 661	WERKZEUGSATZ TOOL SET <i>besteht aus / consists of</i> ▶	1 R	WZ f. Wasserpumpe 531 200 03 01 f. 8V-Motor Tools for water pump 531 200 03 01 for 8V- engine	
	▶ F6 559 664	ADAPTER ADAPTER	1	für Zahnrad A für Prüfen des Haftmomentes for Gear A To check torque of impeller nut.	
	▶ F6 559 667	ADAPTER ADAPTER	1	für Laufrad for Impeller	
	▶ F6 559 668	ABZIEHVORRICHTUNG EXTRACTING FIXTURE	1	für Zahnrad for Gear	
	▶ F6 559 670	DRUCKSCHRAUBE THRUST SCREW	1	M20X1,5 für Zahnrad abziehen M20X1.5, for gear removal	

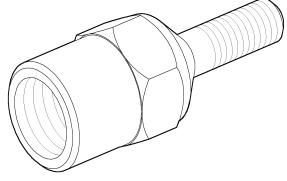
Oz	Sach-Nr. Part Number	Benennung Designation	Stück Qty	Verwendung / Used for Abmessung / Size	Seite/Page 49 von/of 109
	F6 559 662	WERKZEUGSATZ TOOL SET <i>besteht aus / consists of</i> ▶	1 R	WZ für Wasserpumpe 536 200 13 01 f. Serien- Motor Tools for coolant pump 536 200 13 01 for series engine	
	▶ F6 559 664	ADAPTER ADAPTER	1	für Zahnrad A für Prüfen des Haftmomentes for Gear A To check torque of impeller nut.	
	▶ F6 559 665	ADAPTER ADAPTER	1	für Laufrad for Impeller	
	▶ F6 559 668	ABZIEHVORRICHTUNG EXTRACTING FIXTURE	1	für Zahnrad for Gear	
	▶ F6 559 670	DRUCKSCHRAUBE THRUST SCREW	1	M20X1,5 für Zahnrad abziehen M20X1.5, for gear removal	
	▶ F6 785 365	ABZIEHVORRICHTUNG PULLER	1	M16 für Laufrad M16 for impeller	

Oz	Sach-Nr. Part Number	Benennung Designation	Stück Qty	Verwendung / Used for Abmessung / Size	Seite/Page 50 von/of 109
	F6 780 562	ABZIEHVORRICHTUNG EXTRACTING FIXTURE <i>dazu / plus</i> +	1 R	Laufрад von Frischwasserpumpe mit Gewinde M 20 x 1,5 abziehen Pull impeller from coolant pump with M20 x 1.5 thread.	
	+ F6 781 539	HYDR. DRUCKSPINDEL HYDR. PRESS. SPINDLE	1	zu den Werkzeugen F6 780 561 F6 781 600 for tools F6 780 561 F6 781 600	
	F6 781 600	ABZIEHVORRICHTUNG EXTRACTING FIXTURE <i>dazu / plus</i> +	1 R	Laufрад von Seewasserpumpe mit Gewinde M18 x 1,5 abziehen Pull impeller from coolant pump with M18 x 1.5 thread.	
	+ F6 781 539	HYDR. DRUCKSPINDEL HYDR. PRESS. SPINDLE	1	zu den Werkzeugen F6 780 561 F6 781 600 for tools F6 780 561 F6 781 600	

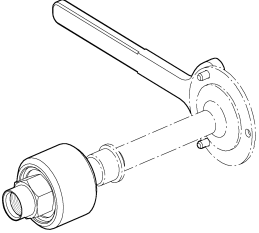

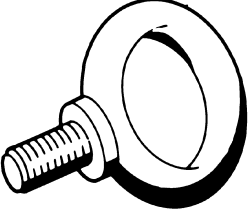
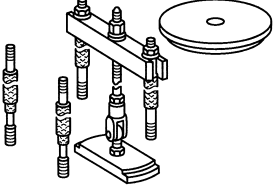
Oz	Sach-Nr. Part Number	Benennung Designation	Stück Qty	Verwendung / Used for Abmessung / Size	Seite/Page 51 von/of 109
	F6 781 674	EINZIEHVORRICHTUNG INSTALLATION FIXTURE	1	Generator-Antriebswelle 531 155 01 03 in Motorträger 531 230 02 77 einbauen Install battery-chrging- generator drive shaft 531 155 01 03 in mounting bracket	 <small>F6781674a</small>

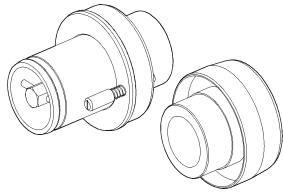
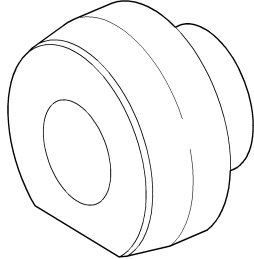
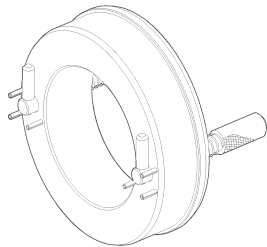
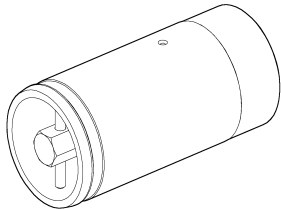
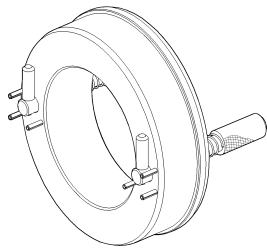
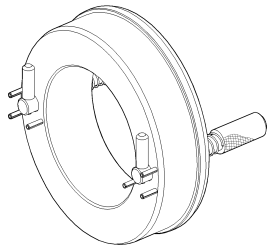
Oz	Sach-Nr. Part Number	Benennung Designation	Stück Qty	Verwendung / Used for Abmessung / Size	Seite/Page 52 von/of 109
	000580 016002	RINGSCHRAUBE SCREW	4	M16 für Schwungradgehäuse M16, for flywheel housing	
	541 589 01 33/00	EIN-U.AUSZIEHVORR. PULLER/EXTRACTOR	1	für Laufbuchse Installer + puller for liner	

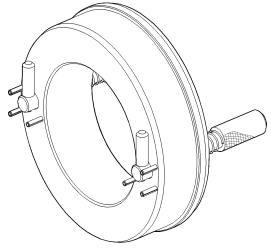
Oz	Sach-Nr. Part Number	Benennung Designation	Stück Qty	Verwendung / Used for Abmessung / Size	Seite/Page 53 von/of 109
	F0 140 549	ZB FUEHRUNGSDORN GUIDE BUSHING <i>besteht aus / consists of</i> ▶	1	12V / 16V Schwungradgehäuse zur KW ausrichten M24 X 2 KW-Gewinde 12V/16V: to align flywheel housing to crankshaft M24 X 2 thread	
	▶ F6 557 981	FUEHRUNGSBUCHSE GUIDE BUSH	1	f. Ausrichtvorr. Schwungradge. flywheel housing	
	▶ F6 559 615	FUEHRUNGSRING GUIDE RING	1	Schwungradgehäuse ausrichten Align flywheel housing	 <small>F6559615a</small>
	▶ F6 780 595	FUEHRUNGSBUCHSE GUIDE BUSHING	1	Schwungradgehäuse 536 013 00 10 zur KW ausrichten M24 X 2 KW-Gewinde Align flywheel housing 536 013 00 10 to crankshaft M24 X 2	 <small>F6780595a</small>
	+ F6 783 891	FUEHRUNGSRING GUIDE RING <i>zusätzlich zu besteht aus / plus consists of</i>	1	für Reparaturstufe 1 = ø 179,642mm KW- Lagerbuchsenbohrung for repair stage 1 = ø 179.642mm crankshaft bearing bore	
	+ F6 783 892	FUEHRUNGSRING GUIDE RING <i>zusätzlich zu besteht aus / plus consists of</i>	1	für Reparaturstufe 2 = ø 179,142mm KW- Lagerbuchsenbohrung for repair stage 2 = ø 179.142mm crankshaft bearing bore	

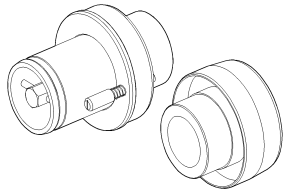
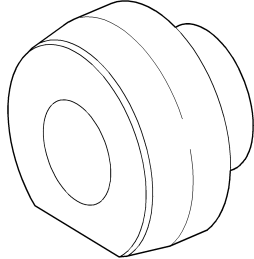
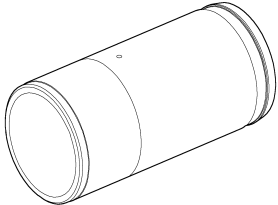
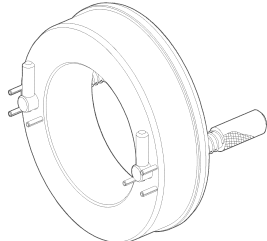
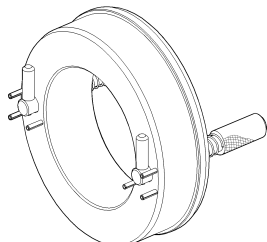
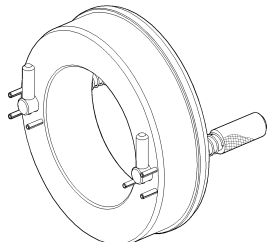
Oz	Sach-Nr. Part Number	Benennung Designation	Stück Qty	Verwendung / Used for Abmessung / Size	Seite/Page 54 von/of 109
	+ F6 783 893	FUEHRUNGSRING GUIDE RING <i>zusätzlich zu besteht aus / plus consists of</i>	1	für Reparaturstufe 3 = \emptyset 178,642mm KW- Lagerbuchsenbohrung for repair stage 3 = \emptyset 178.642mm crankshaft bearing bore	

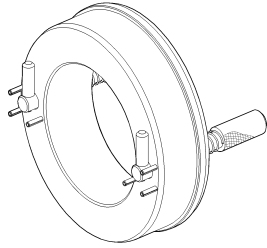
Oz	Sach-Nr. Part Number	Benennung Designation	Stück Qty	Verwendung / Used for Abmessung / Size	Seite/Page 55 von/of 109
	F0 140 550	ZB FUEHRUNGSDORN GUIDE MANDREL <i>besteht aus / consists of</i> ▶	1	18 V 2000, Schwungradgehäuse 522 013 04 10 zu KW ausrichten 18V 2000: to align flywheel housing 522 013 04 10 to crankshaft	
	▶ F6 557 981	FUEHRUNGSBUCHSE GUIDE BUSH	1	f. Ausrichtvorr. Schwungradge. flywheel housing	
	▶ F6 559 614	FUEHRUNGSBUCHSE GUIDE BUSHING	1	Schwungradgehäuse zu KW ausrichten to align flywheel housing to crankshaft	 <small>F6559614a</small>
	▶ F6 559 615	FUEHRUNGSRING GUIDE RING	1	Schwungradgehäuse ausrichten Align flywheel housing	 <small>F6559615a</small>
	+ F6 783 891	FUEHRUNGSRING GUIDE RING <i>zusätzlich zu besteht aus / plus consists of</i>	1	für Reparaturstufe 1 = ø 179,642mm KW- Lagerbuchsenbohrung for repair stage 1 = ø 179.642mm crankshaft bearing bore	
	+ F6 783 892	FUEHRUNGSRING GUIDE RING <i>zusätzlich zu besteht aus / plus consists of</i>	1	für Reparaturstufe 2 = ø 179,142mm KW- Lagerbuchsenbohrung for repair stage 2 = ø 179.142mm crankshaft bearing bore	

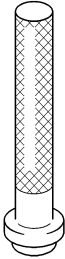
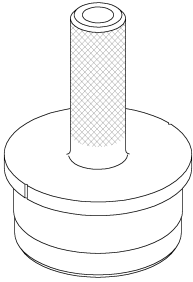
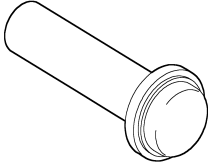
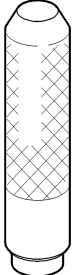
Oz	Sach-Nr. Part Number	Benennung Designation	Stück Qty	Verwendung / Used for Abmessung / Size	Seite/Page 56 von/of 109
	+ F6 783 893	FUEHRUNGSRING GUIDE RING <i>zusätzlich zu besteht aus / plus consists of</i>	1	für Reparaturstufe 3 = \emptyset 178,642mm KW- Lagerbuchsenbohrung for repair stage 3 = \emptyset 178.642mm crankshaft bearing bore	
	F3 0004 455	EINMAULSCHLUESSEL OPEN-END WRENCH	1	SW 65 für Auf- und Abpressvorrichtungen 65 A/F for installation/removal jigs	
	F3 0096 497	EINSCHLAGDORN PUNCH 28 MM	1	Verschlussd. \emptyset 28, 5370160133 KG SEED end cover dia. 28, 5370160133 crkcs. SEED	
	F3 0377 289	SCHRUMPFWERKZEUG SHRINKAGE TOOL	1	8V - 18V Motor f. NW-Bund-Lager 8V - 18V Engine for camshaft bearing	
	F3 0378 754	MONTAGEDORN ASSEMBLY MANDREL	1	für Verschlussdeckel 50 \emptyset im Motor-V for plug 50 \emptyset in engine Vee	
	F3 0378 876	EINSCHLAGDORN DRIFT	1	Verschlussd. \emptyset 32, 5550160233 KG Serie end cover dia.32, 5550160233 crkcs. Series	

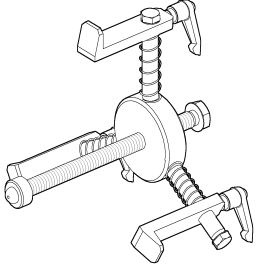
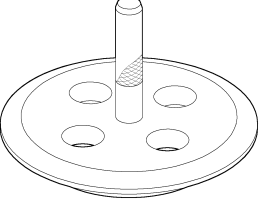
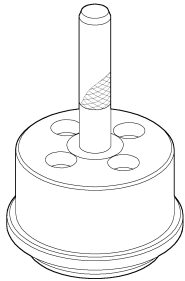
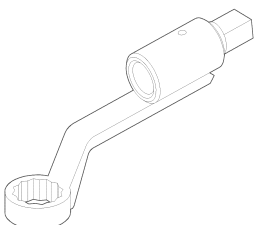
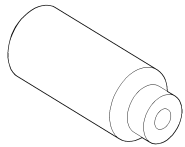
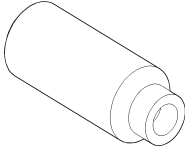

Oz	Sach-Nr. Part Number	Benennung Designation	Stück Qty	Verwendung / Used for Abmessung / Size	Seite/Page 57 von/of 109
	F3 0379 303	AUSZIEHWERKZEUG EXTRACTING TOOL	1	12V/18V, Wellendichtring aus Räderk.-Deckel u. Schwungradgehäuse ausziehen 12V/18V, pull shaft seal out of gearcase cover and flywheel housing	 F30379303a
	F3 0379 791	EINSCHLAGWERKZEUG INSTALLATION TOOL	1	für 12v-18V 2000G und 16V M, Wellendichtring 0249975047 in Schwungradgehäuse SAE 0 einpressen for 12V-18V 2000G and 16V M, hydr. installation of shaft seal 0249975047 in flywheel housing SAE 0	 F30379791a
	F3 0379 792	EINSCHLAGWERKZEUG INSTALLATION TOOL	1	BR 8V/12V 2000M, Wellendichtring in Schwungradgehäuse SAE 1 531 010 11 37 einpressen 8/12V 2000 M, press shaft seal into SAE 1 flywheel housing 531 010 11 37	 F30379792a
	F3 0379 891	EINSTECK-RINGSCHL. BOX WRENCH	1	12V/16V Marine Motor Motoraufhängung 536 223 03 41 an/abbauen 12/16V marine engine, install remove engine mount 536 223 03 41	 F30379891a
	F3 0450 559	EINDRUECKWERKZEUG PRESS-IN TOOL	1	für Fixierstift 4mm ø von KW-Axiallager for locating pin 4mm ø of cranskaft thrust bearing	
	F3 0450 560	EINDRUECKWERKZEUG PRESS-IN TOOL	1	für Fixierstift 6mm ø von KW-Axiallager for locating pin 6mm ø of cranskaft thrust bearing	

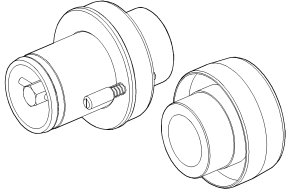
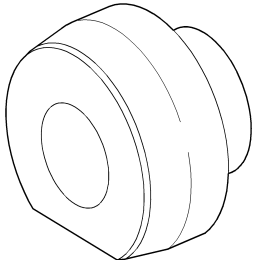
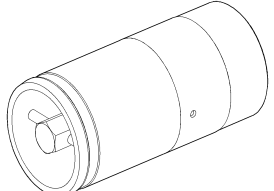
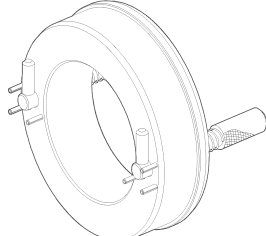
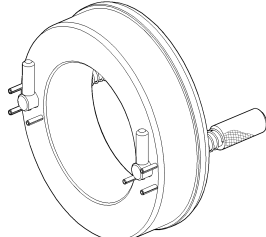
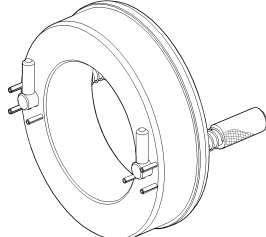

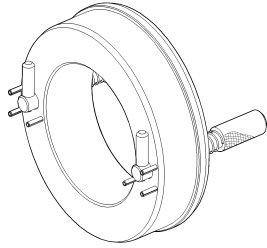
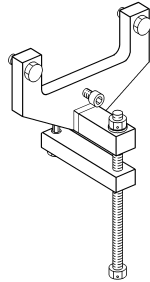
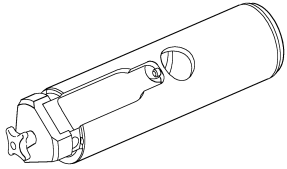
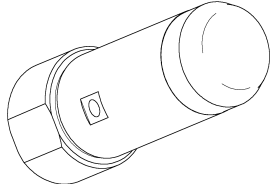
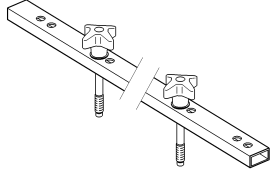
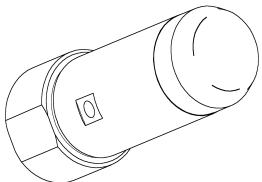
Oz	Sach-Nr. Part Number	Benennung Designation	Stück Qty	Verwendung / Used for Abmessung / Size	Seite/Page 58 von/of 109
	F3 0450 627	AUSZIEHWERKZEUG PULLER	1	für Zwischenradachse von Nebenabtrieb for idler gear shaft of auxiliary PTO	

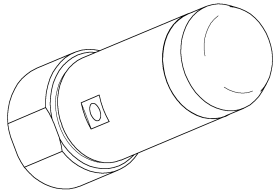
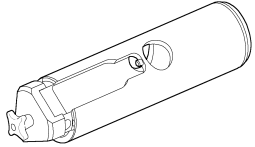
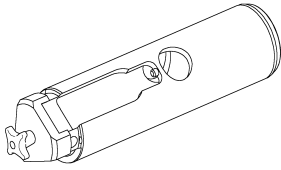
Oz	Sach-Nr. Part Number	Benennung Designation	Stück Qty	Verwendung / Used for Abmessung / Size	Seite/Page 59 von/of 109
	F6 552 386	AUSRICHTVORRICHTUNG ALIGNMENT JIG <i>besteht aus / consists of</i> ▶	1	Schwungradgehäuse für M20 X1,5 KW-Gewinde flywheel housing	
	▶ F6 557 981	FUEHRUNGSBUCHSE GUIDE BUSH	1	f. Ausrichtvorr. Schwungradge. flywheel housing	
	▶ F6 559 613	FUEHRUNGSBUCHSE GUIDE BUSHING	1		
	▶ F6 559 615	FUEHRUNGSRING GUIDE RING	1	Schwungradgehäuse ausrichten Align flywheel housing	 <small>F659615a</small>
	+ F6 783 891	FUEHRUNGSRING GUIDE RING <i>zusätzlich zu besteht aus / plus consists of</i>	1	für Reparaturstufe 1 = ø 179,642mm KW- Lagerbuchsenbohrung for repair stage 1 = ø 179.642mm crankshaft bearing bore	
	+ F6 783 892	FUEHRUNGSRING GUIDE RING <i>zusätzlich zu besteht aus / plus consists of</i>	1	für Reparaturstufe 2 = ø 179,142mm KW- Lagerbuchsenbohrung for repair stage 2 = ø 179.142mm crankshaft bearing bore	

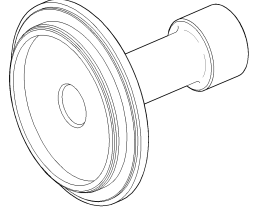
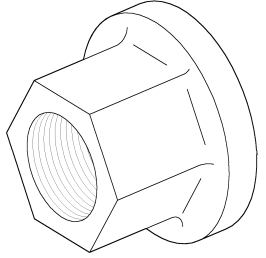
Oz	Sach-Nr. Part Number	Benennung Designation	Stück Qty	Verwendung / Used for Abmessung / Size	Seite/Page 60 von/of 109
	+ F6 783 893	FUEHRUNGSRING GUIDE RING <i>zusätzlich zu besteht aus / plus consists of</i>	1	für Reparaturstufe 3 = \emptyset 178,642mm KW- Lagerbuchsenbohrung for repair stage 3 = \emptyset 178.642mm crankshaft bearing bore	
	F6 555 180	ABSENKVORRICHTUNG JACKSCREW	3	für Ölwanne Marine- Motoren for oil pan for marine engines	
	F6 555 713	FUEHRUNGSRÖHR GUIDE TUBE	1	12V - 18V Motor f. NW-Lager Stufe 0-0 \emptyset 104,065mm 12V - 18V Engine for camshaft bearing stage 0-0 dia. 104.065mm	
	F6 555 714	ANSCHLAGBOLZEN STOP PIN	1	f. 30mm \emptyset Stößelbohr. Standard for 30mm dia. tappet bore, standard	
	F6 555 715	SICHERUNGSSCHIENE SAFETY RAIL	2	Zyl.-Laufbuchsen im KG cyl. liners in crankcase	
	F6 557 924	ANSCHLAGBOLZEN STOP PIN	1	f. 30,25mm \emptyset Stößelbohr. for 30.25mm dia. tappet bore	

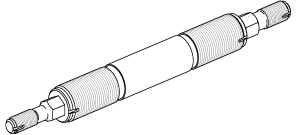
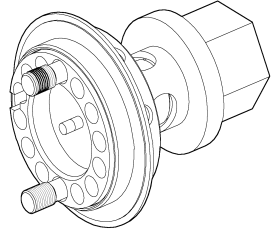
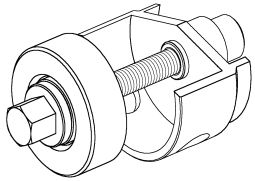
Oz	Sach-Nr. Part Number	Benennung Designation	Stück Qty	Verwendung / Used for Abmessung / Size	Seite/Page 61 von/of 109
	F6 557 925	ANSCHLAGBOLZEN STOP PIN	1	f. 30,5mm ø Stößelbohr. for 30.5mm dia. tappet bore	
	F6 557 951	FUEHRUNGSRÖHR GUIDE TUBE	1	8 V 2000 Nockenwellenlager 531 051 14 10 in Kurbelgehäuse einbauen 8V 2000, install camshaft bearing 531 051 14 10 in crankcase	 <small>F6557951a</small>
	F6 557 976	FUEHRUNGSRÖHR GUIDE TUBE	1	12V - 18V Motor f. NW-Lager Stufe 1-0 ø 104,565mm 12V - 18V Engine for camshaft bearing stage 1-0 dia. 104.565mm	

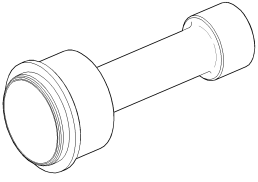
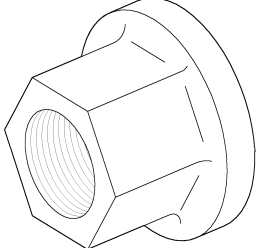
Oz	Sach-Nr. Part Number	Benennung Designation	Stück Qty	Verwendung / Used for Abmessung / Size	Seite/Page 62 von/of 109
	F6 557 982	EINPRESSVORRICHTUNG PRESS-IN DEVICE <i>dazu / plus</i> +	1	für 12v-18V 2000G und 16V M, Wellendichtring 0249975047 in Schwungradgehäuse SAE 0 einpressen for 12V-18V 2000G and 16V M, hydr. installation of shaft seal 0249975047 in flywheel housing SAE 0	
	+ B8 0141 628	SECHSKANTMUTTER HEX NUT	1	M45x2 M45x2	
	+ F3 0004 455	EINMAULSCHLUESSEL OPEN-END WRENCH	1	SW 65 für Auf- und Abpressvorrichtungen 65 A/F for installation/removal jigs	
	+ F6 781 531	ZUGSPINDEL FEED SHAFT	1	M20x1,5 und M24x2 / M45x2 M20x1.5 and M24x2 / M45x2	
	F6 557 983	EINPRESSVORRICHTUNG INSTALLATION JIG	1	8 V 2000 Wellendichtring 541 010 08 33 in Schwunradgehäuse einpressen 8V 2000, press shaft seal 541 010 08 33 into flywheel housing	 <small>F6557983a</small>
	F6 559 618	AUSZIEHWERKZEUG WITHDRAWAL TOOL	1	12V - 18V Motor für Nockenwellenlager 12V - 18V Engine For camshaft bearing	

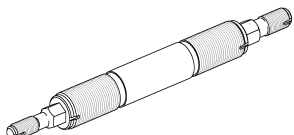
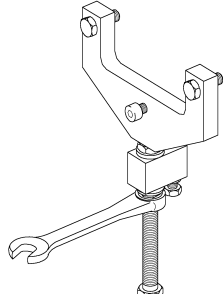
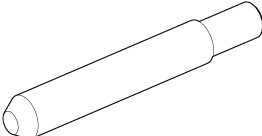
Oz	Sach-Nr. Part Number	Benennung Designation	Stück Qty	Verwendung / Used for Abmessung / Size	Seite/Page 63 von/of 109
	F6 559 645	EINPRESSVORRICHTUNG INSTALLATION TOOL <i>dazu / plus</i> +	1	BR 8V/12V 2000M, Wellendichtring in Schwungradgehäuse SAE 1 531 010 11 37 einpressen 8/12V 2000 M, press shaft seal into SAE 1 flywheel housing 531 010 11 37	
	+ B8 0141 628	SECHSKANTMUTTER HEX NUT	1	M45x2 M45x2	
	+ F3 0004 455	EINMAULSCHLUESSEL OPEN-END WRENCH	1	SW 65 für Auf- und Abpressvorrichtungen 65 A/F for installation/removal jigs	
	+ F6 781 531	ZUGSPINDEL FEED SHAFT	1	M20x1,5 und M24x2 / M45x2 M20x1.5 and M24x2 / M45x2	
	F6 780 489	ABSENKVORRICHTUNG JACKSCREW	4	Absenkvorrr. f. Stahlgußölwanne Aggregatmotor 12-18V Lowering device for cast- steel oil pan; 12 - 18V genset engine	
	F6 780 590	FUEHRUNGSSTIFT GUIDE PIN	4	8 V 2000 Dichtung 541 015 03 80 von Schwungradgehäuse 531 010 08 37 fixieren 8V 2000 secure seal 541 015 03 80 of flywheel housing 531 010 08 37	

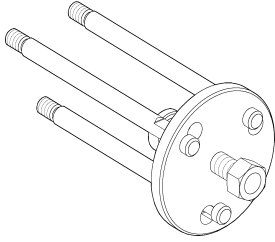
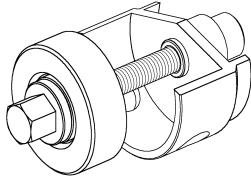
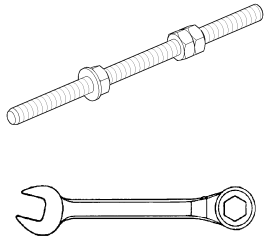
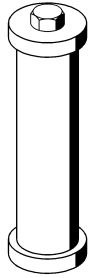
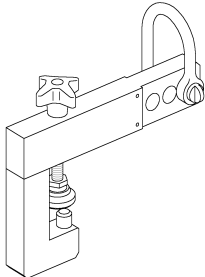
Oz	Sach-Nr. Part Number	Benennung Designation	Stück Qty	Verwendung / Used for Abmessung / Size	Seite/Page 64 von/of 109
	F6 781 202	MONTAGEVORRICHTUNG ASSEMBLY FIXTURE	1	für Zwischenradachse von Nebenabtrieb einbauen for idler gear shaft of auxiliary PTO installation	
	F6 782 199	AUSZIEHWERKZEUG EXTRACTING DEVICE	1	8V 2000 Motor für Nockenwellenlager 8V 2000, for camshaft bearing	
	F6 785 073	ABSENKVORRICHTUNG LOWERING DEVICE	4	für Ölwanne bei engen Einbauverhältnissen for oil pan with small installation clearances	
	T8 0090 973	TRAGBOLZEN CARRIER PIN	2	Tragbolzen für Schwungradgehäuse for flywheel housing, engine removal + installation	
	T8 0091 151	HEBEZEUG LIFTING GEAR	1	für Schwungradgehäuse (Serie und C&I-Motor) Nur zu verwenden, wenn KG um 180° gedreht wird for flywheel housing (series + C&I engines) To be used only when crankcase is rotated 180°.	

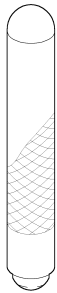
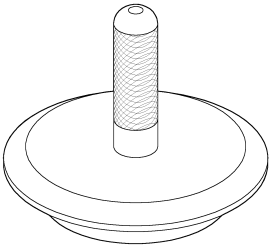
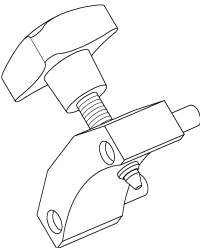
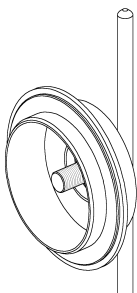
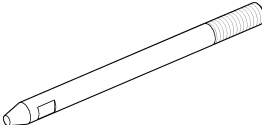
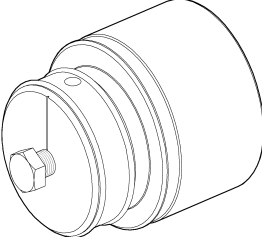
Oz	Sach-Nr. Part Number	Benennung Designation	Stück Qty	Verwendung / Used for Abmessung / Size	Seite/Page 65 von/of 109
	F3 0378 645	EINSCHLAGWERKZEUG INSTALLATION TOOL	1	Zentrierbuchse 235 058 85 in Räderkastendeckel einschlagen von 8V-16V Marinemotoren Install centering sleeve 235 058 85 in gearcase cover of 8V-16V marine engines	 <small>F30378645a</small>
	F3 0378 879	EINSCHLAGDORN DRIFT	1	f. Wellendichtring 5369970047 in Räderkasten ohne KW for shaft seal 5369970047 w/o crankshaft at gearcase ("free") end of engine	
	F6 554 719	ANHALTEVORRICHTUNG RETAINER	1	12/16V M&R-Motor für Antriebsrad Nebenantrieb 12/16V M&R-Engine PTO drive gear	
	F6 557 984	EINPRESSVORRICHTUNG INSTALLATION JIG	1	Wellendichtring in Räderkastendeckel mit M20 x 1,5 KW- Gewinde for shaft seal with embedded crankshaft	
	F6 558 527	FUEHRUNGSBOLZEN GUIDE PIN	4	M10, für Räderkasten M10, for gearcase	
	F6 559 656	AUSRICHTVORRICHTUNG ALIGNMENT FIXTURE	1	18 V 2000, Räderkastendeckel 522 010 01 17 zur Kurbelwelle ausrichten 18V 2000, align flywheel- housing cover 522 010 01 17 to crankshaft	 <small>F6559656a</small>

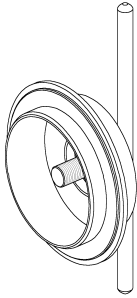
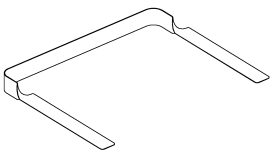
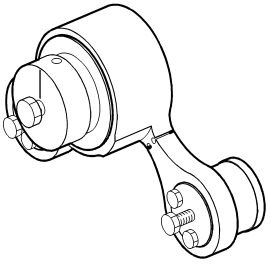
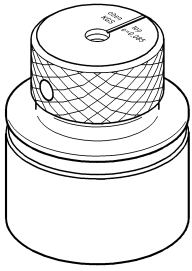
Oz	Sach-Nr. Part Number	Benennung Designation	Stück Qty	Verwendung / Used for Abmessung / Size	Seite/Page 66 von/of 109
	F6 780 507	EINPRESSVORRICHTUNG INSTALLATION TOOL	1	12-18 V , Wellendichtring KGS in Räderkastendeckel mit M24 X 2KW-Gewinde 18V 2000, press shaft seal at free end into flywheel-housing cover	
	Y2 0097 475	ABSTANDSLEHRE DISTANCE CALIBER	1	Z.-Rad f. Nebenabtrieb KS for PTO, driving end	
	Y4 341 101	AUSRICHTVORR. ALIGNMENT JIG <i>dazu / plus</i> +	1	Räderkasten (nur f. SEED-u.SILA-Mot.) for gearcase (for SEED + SILA engines only)	
	+ F6 554 690	AUSRICHTVORR. ALIGNMENT JIG	1	KGS Räderkastendeckel free end, gearcase cover	

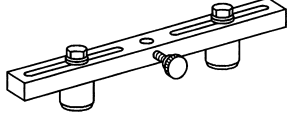
Oz	Sach-Nr. Part Number	Benennung Designation	Stück Qty	Verwendung / Used for Abmessung / Size	Seite/Page 67 von/of 109
	541 589 01 21/00	MESSBRUECKE MEASURING BRIDGE	1	zum OT messen for measuring TDC	

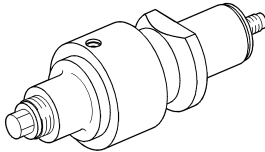
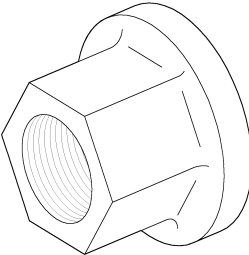
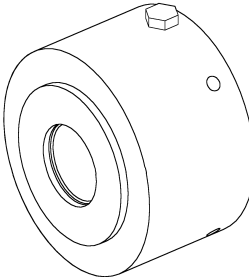
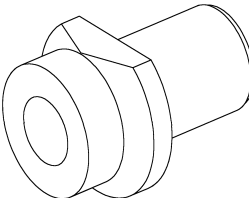
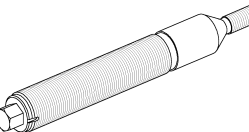
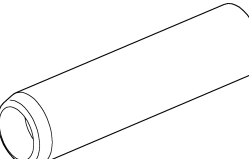
Oz	Sach-Nr. Part Number	Benennung Designation	Stück Qty	Verwendung / Used for Abmessung / Size	Seite/Page 68 von/of 109
	F0 099 855	ZB AUF-,ABPRESSVORR. INST/REM. JIG <i>besteht aus / consists of</i> ▶	1	Schwingungsdämpfer (SEED-Motoren) vibration damper (SEED engines)	
	▶ B8 0141 628	SECHSKANTMUTTER HEX NUT	1	M45x2 M45x2	
	▶ B8 0144 155	HYDRAULIKMUTTER HYDRAULIC NUT	1	M 45 X 2 M 45 X 2	
	▶ F6 554 699	DRUCKBUCHSE THRUST BUSHING	1		
	▶ F6 554 700	ZUGSPINDEL PULLER SPINDLE	1	M20x1,5/M45x2 M20x1.5/M45x2	
	+ F6 558 561	SCHUTZHUELSE PROTECTING SLEEVE <i>zusätzlich zu besteht aus / plus consists of</i>	1	für Zugspindel for draw spindle	

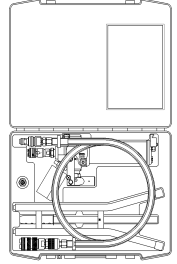
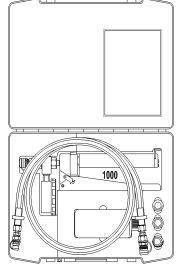
Oz	Sach-Nr. Part Number	Benennung Designation	Stück Qty	Verwendung / Used for Abmessung / Size	Seite/Page 69 von/of 109
	+ B8 0146 887	HANDPUMPENSATZ HAND PUMP SET <i>zusätzlich zu besteht aus / plus consists of</i>	1	3000 bar, für Auf- und Abpresswerkzeuge 3000bar. For press-fit and removal tools.	
	+ B8 0146 893	HANDPUMPENSATZ HAND PUMP SET <i>zusätzlich zu besteht aus / plus consists of</i>	1	1000 bar, für Auf- und Abpresswerkzeuge 1000bar. For press-fit and removal tools.	

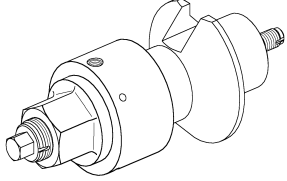
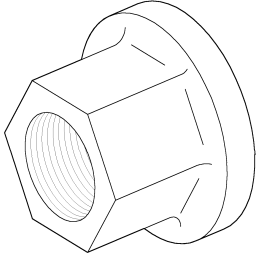
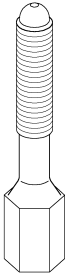
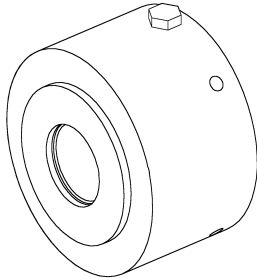
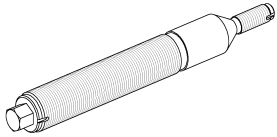
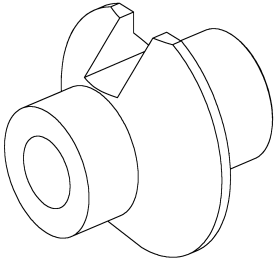
Oz	Sach-Nr. Part Number	Benennung Designation	Stück Qty	Verwendung / Used for Abmessung / Size	Seite/Page 70 von/of 109
	F0 099 856	ZB AUF-,ABPRESSVORR. HYD. INST/REM. JIG <i>besteht aus / consists of</i> ▶	1	KW-Nabe (nur f. SILA u.SEED-Mot.) cr. hub (for SILA + SEED engines only)	
	▶ B8 0141 628	SECHSKANTMUTTER HEX NUT	1	M45x2 M45x2	
	▶ B8 0144 092	REDUZIERSTUECK R1/4" ADAPTER TO 1/4"	1	R1/4"-R1/4" R1/4"-R1/4"	
	▶ B8 0144 155	HYDRAULIKMUTTER HYDRAULIC NUT	1	M 45 X 2 M 45 X 2	
	▶ F6 554 700	ZUGSPINDEL PULLER SPINDLE	1	M20x1,5/M45x2 M20x1.5/M45x2	
	▶ F6 554 702	DRUCKBUCHSE THRUST BUSH	1		

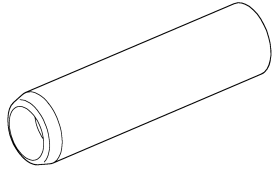
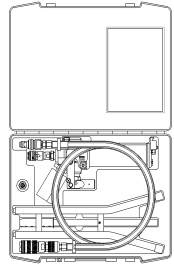
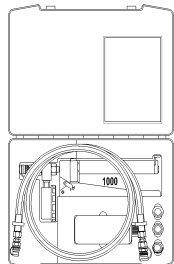
Oz	Sach-Nr. Part Number	Benennung Designation	Stück Qty	Verwendung / Used for Abmessung / Size	Seite/Page 71 von/of 109
	+ F6 558 561	SCHUTZHUELSE PROTECTING SLEEVE <i>zusätzlich zu besteht aus / plus consists of</i>	1	für Zugspindel for draw spindle	
	+ B8 0146 887	HANDPUMPENSATZ HAND PUMP SET <i>zusätzlich zu besteht aus / plus consists of</i>	1	3000 bar, für Auf- und Abpresswerkzeuge 3000bar. For press-fit and removal tools.	
	+ B8 0146 893	HANDPUMPENSATZ HAND PUMP SET <i>zusätzlich zu besteht aus / plus consists of</i>	1	1000 bar, für Auf- und Abpresswerkzeuge 1000bar. For press-fit and removal tools.	

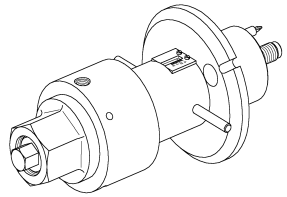
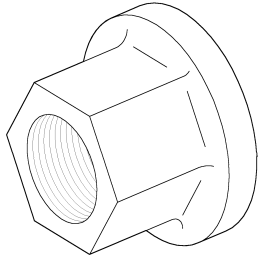
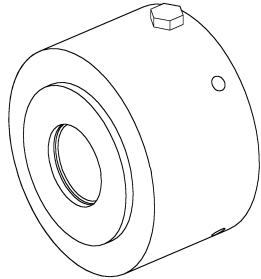
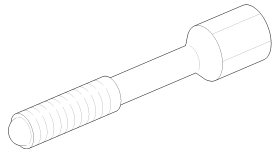
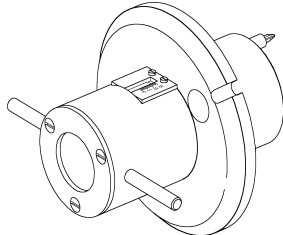
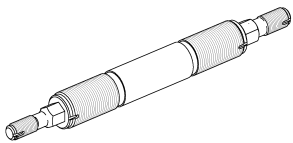
Oz	Sach-Nr. Part Number	Benennung Designation	Stück Qty	Verwendung / Used for Abmessung / Size	Seite/Page 72 von/of 109
	F0 099 990	ZB AUF-,ABPRESSVORR. INSTALL/REM. JIG <i>besteht aus / consists of</i> ▶	1	KW-Nabe, KS (f. Marine- Motoren) crankshaft hub , KS (for marine engines)	
	▶ B8 0141 628	SECHSKANTMUTTER HEX NUT	1	M45x2 M45x2	
	▶ B8 0144 155	HYDRAULIKMUTTER HYDRAULIC NUT	1	M 45 X 2 M 45 X 2	
	▶ B8 0144 754	REDUZIERSTUECK REDUCER	1	R1/4"-R1/4" R1/4"-R1/4"	
	▶ F6 557 174	DRUCKBUCHSE THRUST BUSHING	1		
	▶ F6 781 531	ZUGSPINDEL FEED SHAFT	1	M20x1,5 und M24x2 / M45x2 M20x1.5 and M24x2 / M45x2	

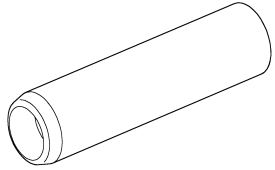
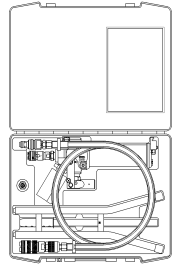
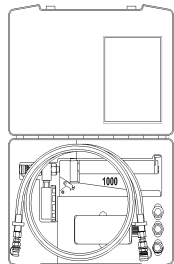
Oz	Sach-Nr. Part Number	Benennung Designation	Stück Qty	Verwendung / Used for Abmessung / Size	Seite/Page 73 von/of 109
	+ F6 558 561	SCHUTZHUELSE PROTECTING SLEEVE <i>zusätzlich zu besteht aus / plus consists of</i>	1	für Zugspindel for draw spindle	
	+ B8 0146 887	HANDPUMPENSATZ HAND PUMP SET <i>zusätzlich zu besteht aus / plus consists of</i>	1	3000 bar, für Auf- und Abpresswerkzeuge 3000bar. For press-fit and removal tools.	
	+ B8 0146 893	HANDPUMPENSATZ HAND PUMP SET <i>zusätzlich zu besteht aus / plus consists of</i>	1	1000 bar, für Auf- und Abpresswerkzeuge 1000bar. For press-fit and removal tools.	

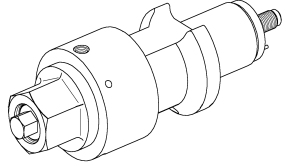
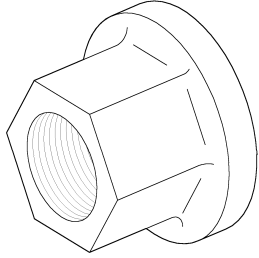
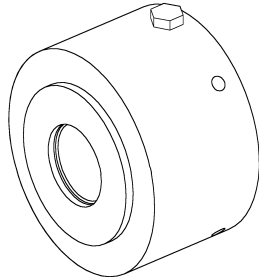
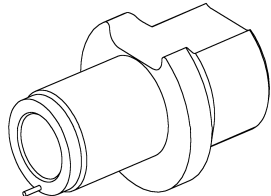
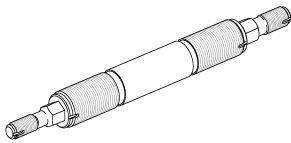
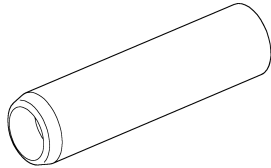
Oz	Sach-Nr. Part Number	Benennung Designation	Stück Qty	Verwendung / Used for Abmessung / Size	Seite/Page 74 von/of 109
	F0 099 996	ZB AUF-/ABPRESSVORR. INSTALL/REM. JIG <i>besteht aus / consists of</i> ▶	1	Schwingungsdämpfer (SILA-12V/16V Serie-, 16V-C&I und 12-18V G Motoren) ebenso f. 8V- 18V Dämpfer-Mitnehmerfl. vibration damper/flange (SILA 12V/16V series, 16V C&I and 12-18V G engines), also for 8V-18V damper driver flange	
	▶ B8 0141 628	SECHSKANTMUTTER HEX NUT	1	M45x2 M45x2	
	▶ B8 0144 155	HYDRAULIKMUTTER HYDRAULIC NUT	1	M 45 X 2 M 45 X 2	
	▶ F6 557 199	DRUCKBUCHSE THRUST BUSHING	1	ø 45,2 dia. 45.2	
	▶ F6 781 531	ZUGSPINDEL FEED SHAFT	1	M20x1,5 und M24x2 / M45x2 M20x1.5 and M24x2 / M45x2	
	+ F6 558 561	SCHUTZHUELSE PROTECTING SLEEVE <i>zusätzlich zu besteht aus / plus consists of</i>	1	für Zugspindel for draw spindle	

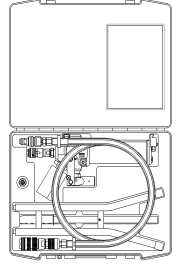
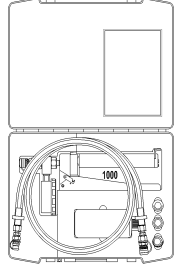
Oz	Sach-Nr. Part Number	Benennung Designation	Stück Qty	Verwendung / Used for Abmessung / Size	Seite/Page 75 von/of 109
	+ B8 0146 887	HANDPUMPENSATZ HAND PUMP SET <i>zusätzlich zu besteht aus / plus consists of</i>	1	3000 bar, für Auf- und Abpresswerkzeuge 3000bar. For press-fit and removal tools.	
	+ B8 0146 893	HANDPUMPENSATZ HAND PUMP SET <i>zusätzlich zu besteht aus / plus consists of</i>	1	1000 bar, für Auf- und Abpresswerkzeuge 1000bar. For press-fit and removal tools.	

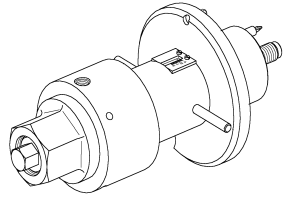
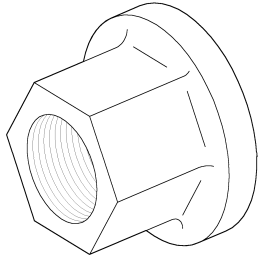
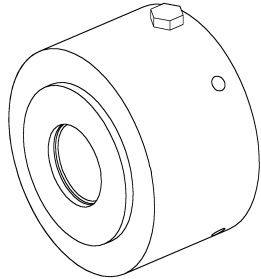
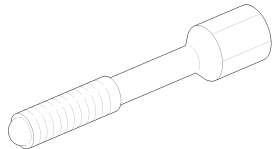
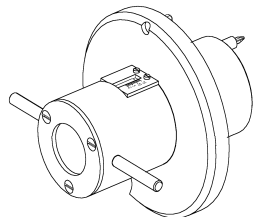
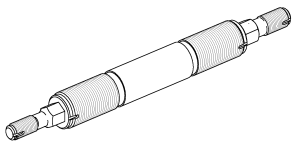
Oz	Sach-Nr. Part Number	Benennung Designation	Stück Qty	Verwendung / Used for Abmessung / Size	Seite/Page 76 von/of 109
	F0 140 150	ZB AUF/ABPRESSVORR. INST/REMOV JIG <i>besteht aus / consists of</i> ▶	1	Schwungrad 12/16V G02 Motor flywheel 12/16V G02 engine	
	▶ B8 0141 628	SECHSKANTMUTTER HEX NUT	1	M45x2 M45x2	
	▶ B8 0144 155	HYDRAULIKMUTTER HYDRAULIC NUT	1	M 45 X 2 M 45 X 2	
	▶ B8 0144 754	REDUZIERSTUECK REDUCER	1	R1/4"-R1/4" R1/4"-R1/4"	
	▶ F6 558 525	DRUCKBUCHSE THRUST BUSHING	1		
	▶ F6 781 531	ZUGSPINDEL FEED SHAFT	1	M20x1,5 und M24x2 / M45x2 M20x1.5 and M24x2 / M45x2	

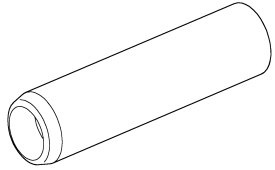
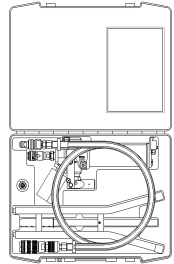
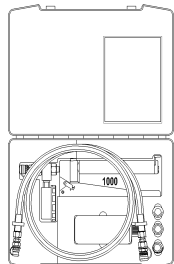
Oz	Sach-Nr. Part Number	Benennung Designation	Stück Qty	Verwendung / Used for Abmessung / Size	Seite/Page 77 von/of 109
	+ F6 558 561	SCHUTZHUELSE PROTECTING SLEEVE <i>zusätzlich zu besteht aus / plus consists of</i>	1	für Zugspindel for draw spindle	
	+ B8 0146 887	HANDPUMPENSATZ HAND PUMP SET <i>zusätzlich zu besteht aus / plus consists of</i>	1	3000 bar, für Auf- und Abpresswerkzeuge 3000bar. For press-fit and removal tools.	
	+ B8 0146 893	HANDPUMPENSATZ HAND PUMP SET <i>zusätzlich zu besteht aus / plus consists of</i>	1	1000 bar, für Auf- und Abpresswerkzeuge 1000bar. For press-fit and removal tools.	

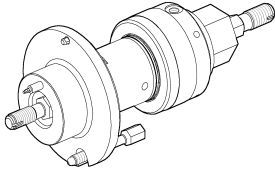
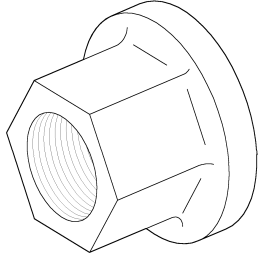
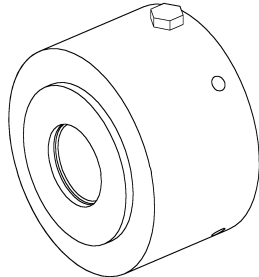
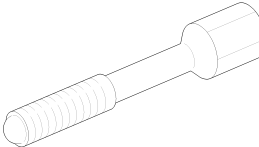
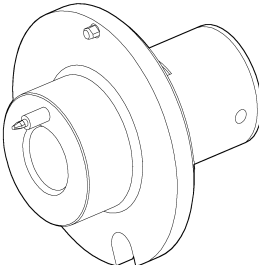
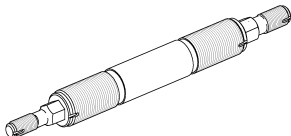
Oz	Sach-Nr. Part Number	Benennung Designation	Stück Qty	Verwendung / Used for Abmessung / Size	Seite/Page 78 von/of 109
	F0 140 155	ZB AUF/ABPR-VORRICHT REM/INST. JIG <i>besteht aus / consists of</i> ▶	1	18 V 2000, Schwungrad 522 030 06 05 auf KW auf/abpressen 18V 2000, hydraulically install/remove flywheel 522 030 06 05 onto crankshaft□	 <small>F0140155a</small>
	▶ B8 0141 628	SECHSKANTMUTTER HEX NUT	1	M45x2 M45x2	
	▶ B8 0144 155	HYDRAULIKMUTTER HYDRAULIC NUT	1	M 45 X 2 M 45 X 2	
	▶ B8 0144 754	REDUZIERSTUECK REDUCER	1	R1/4"-R1/4" R1/4"-R1/4"	
	▶ F6 559 610	DRUCKBUCHSE THRUST BUSH	1		 <small>F6559610a</small>
	▶ F6 781 531	ZUGSPINDEL FEED SHAFT	1	M20x1,5 und M24x2 / M45x2 M20x1.5 and M24x2 / M45x2	

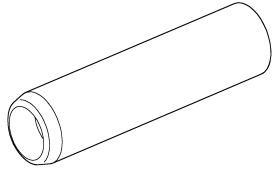
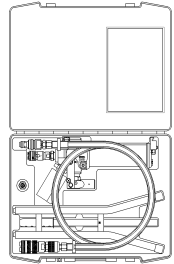
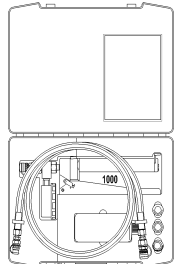
Oz	Sach-Nr. Part Number	Benennung Designation	Stück Qty	Verwendung / Used for Abmessung / Size	Seite/Page 79 von/of 109
	+ F6 558 561	SCHUTZHUELSE PROTECTING SLEEVE <i>zusätzlich zu besteht aus / plus consists of</i>	1	für Zugspindel for draw spindle	
	+ B8 0146 887	HANDPUMPENSATZ HAND PUMP SET <i>zusätzlich zu besteht aus / plus consists of</i>	1	3000 bar, für Auf- und Abpresswerkzeuge 3000bar. For press-fit and removal tools.	
	+ B8 0146 893	HANDPUMPENSATZ HAND PUMP SET <i>zusätzlich zu besteht aus / plus consists of</i>	1	1000 bar, für Auf- und Abpresswerkzeuge 1000bar. For press-fit and removal tools.	

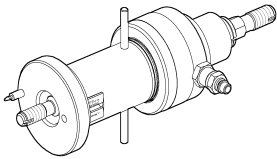
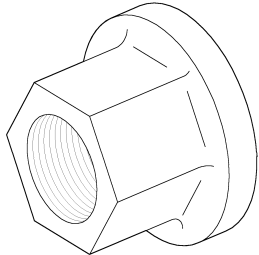
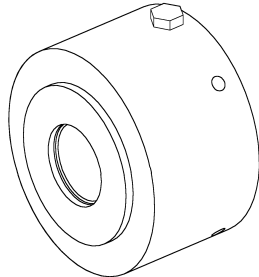
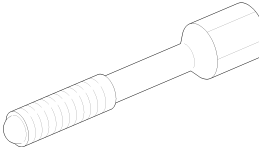
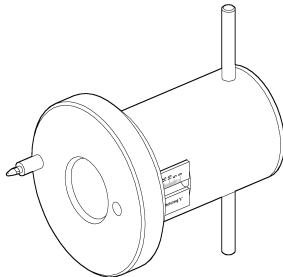
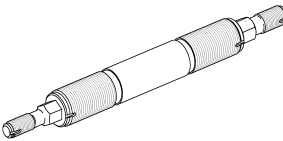
Oz	Sach-Nr. Part Number	Benennung Designation	Stück Qty	Verwendung / Used for Abmessung / Size	Seite/Page 80 von/of 109
	F0 140 165	ZB AUF/ABPRESSVORR HYDR INSTAL/REM DEV <i>besteht aus / consists of</i> ▶	1	Schwungrad 535 030 06 05 12 V Marine auf KW auf/abpressen 535 000 01 03 Install/remove flywheel 535 030 06 05 12 V Marine hydraulically onto/from crankshaft	 <small>F0140165a</small>
	▶ B8 0141 628	SECHSKANTMUTTER HEX NUT	1	M45x2 M45x2	
	▶ B8 0144 155	HYDRAULIKMUTTER HYDRAULIC NUT	1	M 45 X 2 M 45 X 2	
	▶ B8 0144 754	REDUZIERSTUECK REDUCER	1	R1/4"-R1/4" R1/4"-R1/4"	
	▶ F6 559 690	DRUCKBUCHSE THRUST BUSHING	1	für Schwungrad for flywheel	 <small>F6559690a</small>
	▶ F6 781 531	ZUGSPINDEL FEED SHAFT	1	M20x1,5 und M24x2 / M45x2 M20x1.5 and M24x2 / M45x2	

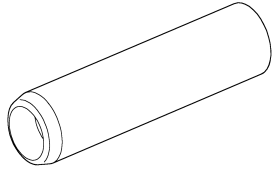
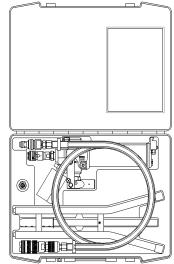
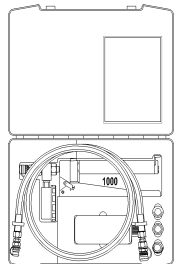
Oz	Sach-Nr. Part Number	Benennung Designation	Stück Qty	Verwendung / Used for Abmessung / Size	Seite/Page 81 von/of 109
	+ F6 558 561	SCHUTZHUELSE PROTECTING SLEEVE <i>zusätzlich zu besteht aus / plus consists of</i>	1	für Zugspindel for draw spindle	
	+ B8 0146 887	HANDPUMPENSATZ HAND PUMP SET <i>zusätzlich zu besteht aus / plus consists of</i>	1	3000 bar, für Auf- und Abpresswerkzeuge 3000bar. For press-fit and removal tools.	
	+ B8 0146 893	HANDPUMPENSATZ HAND PUMP SET <i>zusätzlich zu besteht aus / plus consists of</i>	1	1000 bar, für Auf- und Abpresswerkzeuge 1000bar. For press-fit and removal tools.	

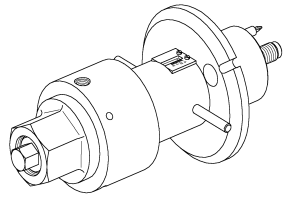
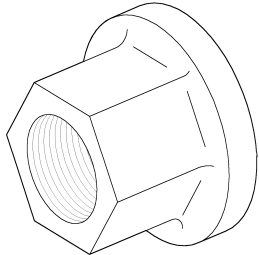
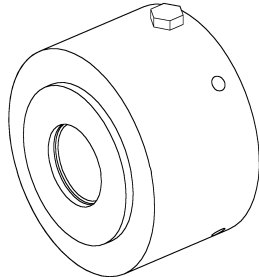
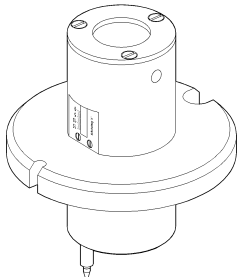
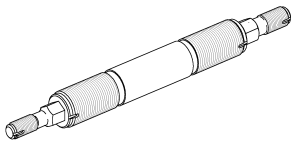
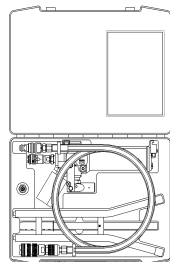
Oz	Sach-Nr. Part Number	Benennung Designation	Stück Qty	Verwendung / Used for Abmessung / Size	Seite/Page 82 von/of 109
	F0 140 172	ZB AUF/ABPRESSVORR HYDR INSTAL/REM DEV <i>besteht aus / consists of</i> ▶	1	KW-Nabe, KS (für 12/16V Generator- Motor) crankshaft hub, KS (for 12/16V genset engine)	
	▶ B8 0141 628	SECHSKANTMUTTER HEX NUT	1	M45x2 M45x2	
	▶ B8 0144 155	HYDRAULIKMUTTER HYDRAULIC NUT	1	M 45 X 2 M 45 X 2	
	▶ F6 780 583	DRUCKBUCHSE THRUST BUSH	1		
	▶ F6 781 531	ZUGSPINDEL FEED SHAFT	1	M20x1,5 und M24x2 / M45x2 M20x1.5 and M24x2 / M45x2	
	+ B8 0146 887	HANDPUMPENSATZ HAND PUMP SET <i>zusätzlich zu besteht aus / plus consists of</i>	1	3000 bar, für Auf- und Abpresswerkzeuge 3000bar. For press-fit and removal tools.	

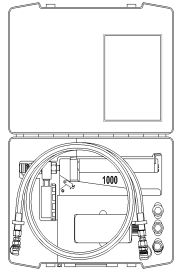
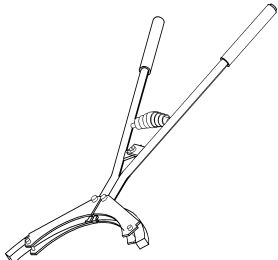
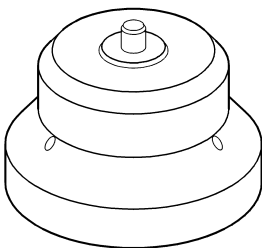
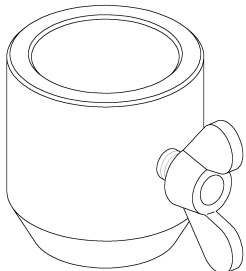
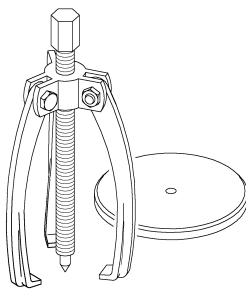
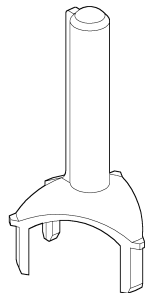
Oz	Sach-Nr. Part Number	Benennung Designation	Stück Qty	Verwendung / Used for Abmessung / Size	Seite/Page 83 von/of 109
	+ B8 0146 893	HANDPUMPENSATZ HAND PUMP SET <i>zusätzlich zu besteht aus / plus consists of</i>	1	1000 bar, für Auf- und Abpresswerkzeuge 1000bar. For press-fit and removal tools.	
	F3 0378 001	KOLBENRINGZANGE PISTON RING PLIERS	1		
	F3 0378 391	AUFPRESSWERKZEUG HYD. INST/REM. JIG <i>dazu / plus</i> +	1	Zahnrad auf Nabe KW - Rad Crankshaft gear onto crankshaft stub	
	+ F3 0275 611	AUFNAHME MOUNT	1	für Dornpresse for mandrel press	
	F3 0379 133	ABZIEHVORRICHTUNG EXTRACTING FIXTURE	1	f. Laufring Schwingungsdämpfer for vibration-dampfer track ring	
	F3 0379 217	EINFUEHRWERKZEUG EXTRACTION TOOL	1	KW-Lager in Räderkasten- Deckel eineisen for chilled installation of crankshaft bearing in gearcase cover	

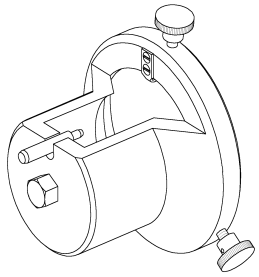
Oz	Sach-Nr. Part Number	Benennung Designation	Stück Qty	Verwendung / Used for Abmessung / Size	Seite/Page 84 von/of 109
	F6 552 506	AUSRICHTVORRICHTUNG ALIGNMENT JIG	1	Kurbelwellenrad KS z. KW crankshaft gear, driving end to crankshaft	

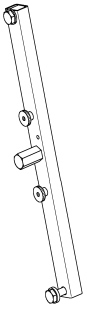
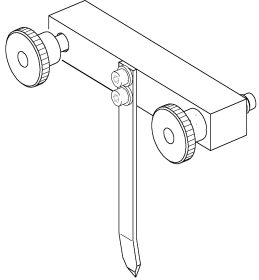
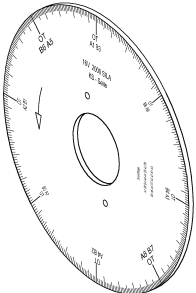
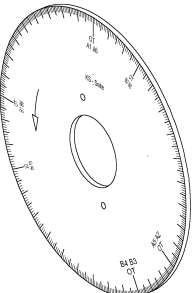
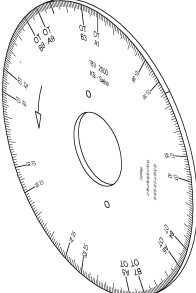
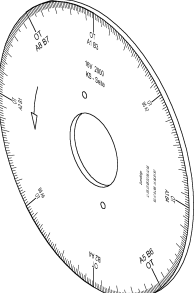
Oz	Sach-Nr. Part Number	Benennung Designation	Stück Qty	Verwendung / Used for Abmessung / Size	Seite/Page 85 von/of 109
	F6 554 695	DURCHDREHVORR. BARRING TOOL <i>dazu / plus</i> +	1	Schwungrad 12 - 18V flywheel 12 - 18V	
	+ F6 554 696	ZEIGER POINTER	1	Schwungradgehäuse flywheel housing	
	+ Y4 341 098	GRADSCHEIBE GRADUATED PLATE	1	16V-Motor SILA-SEED- Motor 16V SILA-SEED engine	
	+ Y4 341 112	GRADSCHEIBE GRADUATED DISC	1	12V-Motor SILA-Motor 12V SILA-engine	
	+ Y4 343 815	GRADSCHEIBE GRADUATED PLATE	1	18V-Serienmotor 18V series engine	
	+ Y4 343 816	GRADSCHEIBE GRADUATED PLATE	1	16V-Serienmotor 16V series engine	

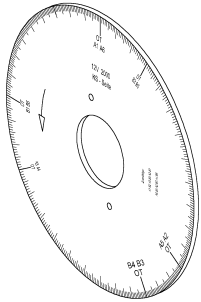
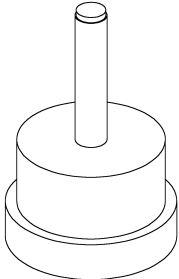
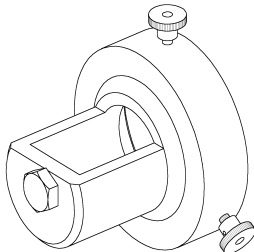
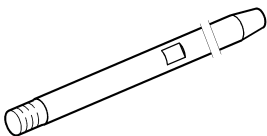
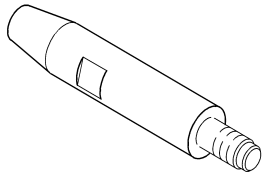
Oz	Sach-Nr. Part Number	Benennung Designation	Stück Qty	Verwendung / Used for Abmessung / Size	Seite/Page 86 von/of 109
	+ Y4 343 817	GRADSCHEIBE GRADUATED PLATE	1	12V-Serienmotor 12V series engine	
	F6 554 708	MONTAGEVORRICHTUNG FIXTURE	1	f.Laufring v. Wellendichtring Schwingungsd. for runner ring of shaft seal, vibration damper	
	F6 554 711	MONTAGEVORRICHTUNG FIXTURE	1	Kurbelwellenrad KGS crankshaft gear, free end	
	F6 555 162	AUFNAHMEBOLZEN LOCATING PIN	2	M16 x 1,5, für Schwungrad M16x1.5, for flywheel	
	F6 555 644	EINFUEHRUNGSBOLZEN GUIDE PIN	4	Kurbelwelle crankshaft	

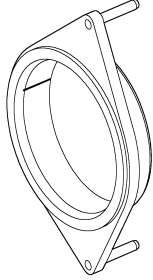
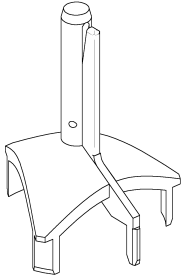
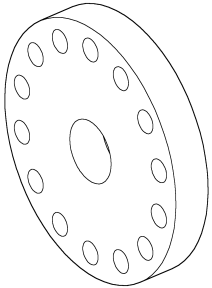
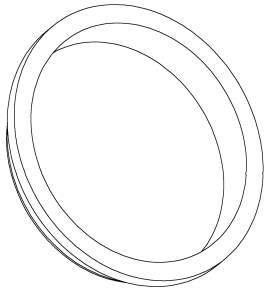
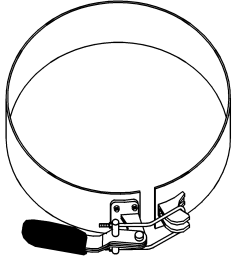
Oz	Sach-Nr. Part Number	Benennung Designation	Stück Qty	Verwendung / Used for Abmessung / Size	Seite/Page 87 von/of 109
	F6 555 761	FUEHRUNGSBUCHSE GUIDE BUSH <i>dazu / plus</i> +	1	KW-Stützlager KS in Schwungradgehäuse eineisen crankshaft support bearing, driving end	
	+ F3 0378 021	SCHRUMPFWERKZEUG SHRINKAGE TOOL	1	KW-Lager in Schwungradgehäuse eineisen crankshaft bearing installation in flywheel housing by icing	
	F6 555 793	ABZIEHVORRICHTUNG EXTRACTING FIXTURE	1	KW-Nabe KS, wenn Nabe sich nicht löst crankshaft hub, driving end	
	F6 557 147	MONTAGEHUELSE ASSEMBLY SLEEVE <i>dazu / plus</i> +	1	Laufbuchse mit Koksabstreifring cylinder liner with carbon scraper ring	
	+ F6 554 678	KOLBENRINGSPANNBAND PISTON RING COMPRESS	1		

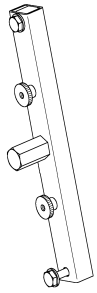
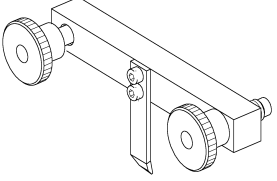
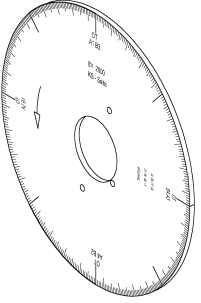
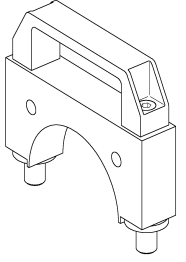
Oz	Sach-Nr. Part Number	Benennung Designation	Stück Qty	Verwendung / Used for Abmessung / Size	Seite/Page 88 von/of 109
	F6 557 929	DURCHDREHVORRICHTUNG BARRING TOOL <i>dazu / plus</i> +	1	für Schwungrad 8V-Motor for flywheel 8V engine	
	+ F6 557 932	ZEIGER POINTER	1	8V-Motor 8V engine	
	+ Y4 341 946	GRADSCHEIBE GRADUATED PLATE	1	8V-Motor 8V engine	
	F6 557 995	MONTAGEVORRICHTUNG FIXTURE	1	f. Pleuellager (Lager ausrichten), Marine-Motor For conrod bearing (alignment), marine engine	

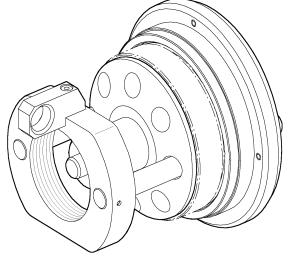
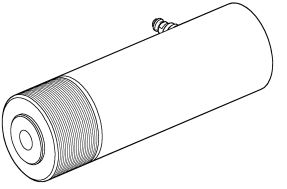
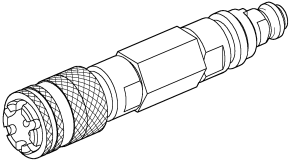
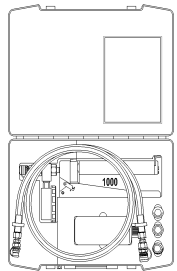
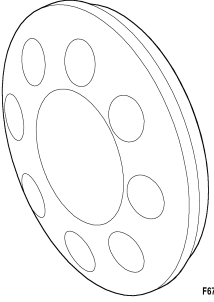
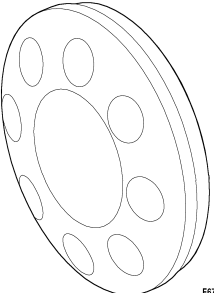
Oz	Sach-Nr. Part Number	Benennung Designation	Stück Qty	Verwendung / Used for Abmessung / Size	Seite/Page 89 von/of 109
	F6 781 536	AUSZIEHVORRICHTUNG EXTRACTING FIXTURE <i>dazu / plus</i> +	1	KW-Lager 536 010 09 37 aus Schwungradgeh. 5360100937, 5220130510 für 18V auspressen, ø 193.2 mm to press crankshaft bearing 5360100937 out of flywheel housing 5360100937.	 <small>F6781536a</small>
	+ B8 0096 717	ZB.LUKAS-ZYLINDER LUKAS PRESS	1	zu Werkzeug F6 781536 for tool F6 781536	
	+ B8 0146 411	ADAPTER ADAPTER	1	Anschluss LUKAS- Zylinder an SKF-Handpumpe Connection for LUCAS cylinder with SKF hand pump	
	+ B8 0146 893	HANDPUMPENSATZ HAND PUMP SET	1	1000 bar, für Auf- und Abpresswerkzeuge 1000bar. For press-fit and removal tools.	
	+ F6 781 562	DRUCKPLATTE PRESSURE PLATE	1	Auss.-ø 130mm, KW Lager 5310330130 aus Räderk.-Deckel 5220100117 Genset-M 12V/18V auspressen Outer diam. 130mm, press crankshaft bearing 5310330130 out of flywheel cover 5220100117. 12V/18V	 <small>F6781562a</small>
	+ F6 781 563	DRUCKPLATTE PRESSURE PLATE	1	Aussen ø 125,4 mm, KW- Lager 5360330030 aus Räderkasten-Deckel 5360100417 Marine- Outer diam. 125.4mm, press crankshaft bearing 5360330030 out of flywheel-housing cover 5360100417. 12/16V	 <small>F6781563a</small>

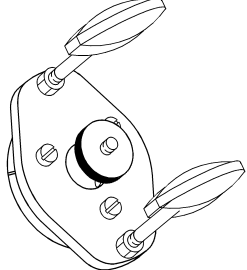
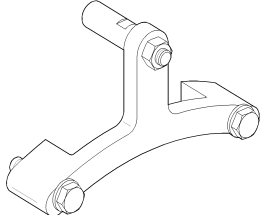
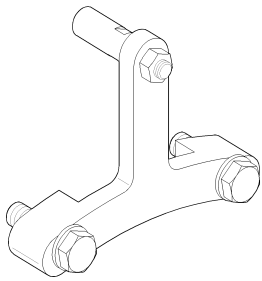
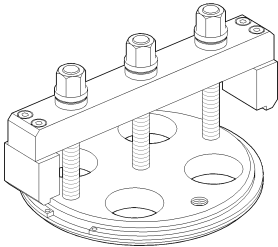
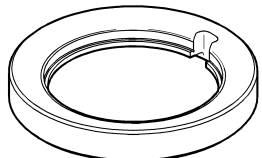
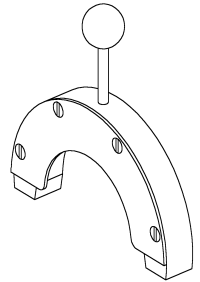
Oz	Sach-Nr. Part Number	Benennung Designation	Stück Qty	Verwendung / Used for Abmessung / Size	Seite/Page 90 von/of 109
	F6 782 138	AUSZIEHVORRICHTUNG EXTRACTION DEVICE	1	8V - 18 V Motor für Kolben und Pleuel 8V - 18 V Engine Puller for piston	
	F6 783 165	ANHALTEVORRICHTUNG RETAINING FIXTURE	1	8V Motor Schwungrad arretieren 8V engine: for flywheel adjustment	
	F6 783 166	ANHALTEVORRICHTUNG RETAINING FIXTURE	1	12V - 18V Motor Schwungrad arretieren 12V/16V engine: for flywheel adjustment	
	F6 785 514	AUSZIEHVORRICHTUNG EXTRACTION DEVICE	1	für Koksabstreifring, 130mm ø for carbon scraper ring, 130mm ø	
	Y4 340 797	MESSRING RING GAUGE	1	ø130mm (Stoßmaß Kolbenring) 130mm (piston ring gap)	
	Y4 341 107	ABSTANDSLEHRE CLEARANCE GAUGE	1	Kurbelwellenrad KGS crankshaft gear, free end	

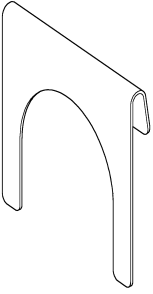
Oz	Sach-Nr. Part Number	Benennung Designation	Stück Qty	Verwendung / Used for Abmessung / Size	Seite/Page 91 von/of 109
	Y4 341 111	ABSTANDSLEHRE CLEARANCE GAUGE	1	Kurbelwellenrad KS crankshaft gear, driving end	

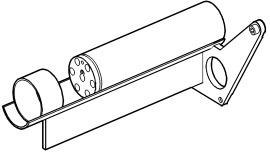
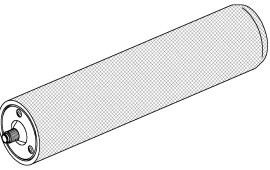
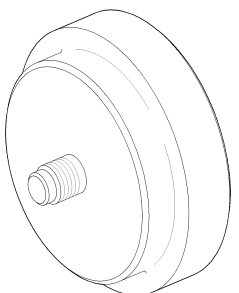
Oz	Sach-Nr. Part Number	Benennung Designation	Stück Qty	Verwendung / Used for Abmessung / Size	Seite/Page 92 von/of 109
	F6 554 679	EINBAUVORRICHTUNG INSTALLATION DEVICE	1	f. Nockenwelle Nur zu verwenden, wenn KG um 180° gedreht for camshaft To be used only when crankcase is rotated 180°.	
	F6 557 148	FUEHRUNGSDORN GUIDE MANDREL	1	8V - 18 V Motor für Nockenwelle 8V - 18 V Engine for camshaft	
	F6 557 158	AXIALFIXIERUNG AXIAL LOCK	1	Motor 8V - 18V NW axial sichern nach Abbau des Räderkasten 8V - 18V engine: for locking camshaft axially after gearcase removal	

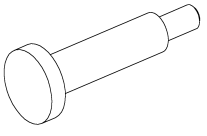
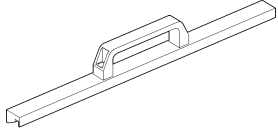
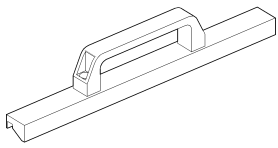
Oz	Sach-Nr. Part Number	Benennung Designation	Stück Qty	Verwendung / Used for Abmessung / Size	Seite/Page 93 von/of 109
	F6 557 159	MONTAGEDORN ASSEMBLY MANDREL	1	Steckrohr Kraftstoff- Führung plug-in pipe, fuel feed	
	F6 783 520	DISTANZLEISTE SPACER BAR (16V) (18V)	4 2	Dichtbeilagen zur Montage der HD- Kraftstofffführung fixieren for locking gaskets into position for HP fuel line installation	
	F6 783 521	DISTANZLEISTE SPACER BAR (12V) (18V)	4 4	Dichtbeilagen zur Montage der HD- Kraftstofffführung fixieren for locking gaskets into position for HP fuel line installation	

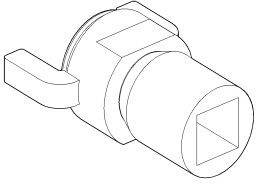
Oz	Sach-Nr. Part Number	Benennung Designation	Stück Qty	Verwendung / Used for Abmessung / Size	Seite/Page 94 von/of 109
	F3 0450 985	STECKSCHLUES-EINSATZ SOCKET	1	zur Montage von Kupplungsstück X00005812 for installation of coupling part X00005812	

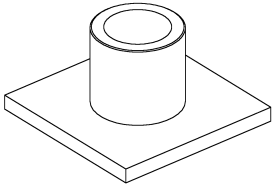
Oz	Sach-Nr. Part Number	Benennung Designation	Stück Qty	Verwendung / Used for Abmessung / Size	Seite/Page 95 von/of 109
	F3 0378 886	AUSPRESSDORN EXTRACTION MANDREL <i>dazu / plus</i> +	1	für Lagerbuchse Ansauggehäuse for bearing bush, intake housing	
	+ F6 558 538	AUFLAGE SUPPORT	1	für Ansauggehäuse for intake housing	

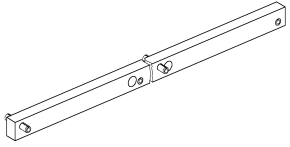
Oz	Sach-Nr. Part Number	Benennung Designation	Stück Qty	Verwendung / Used for Abmessung / Size	Seite/Page 96 von/of 109
	F6 557 105	AUSRICHTSCHIENE ALIGNMENT RAIL	1	Marine Motor Klappengehäuse u. Flanschkrümmer Marine Engines flap housing + flange elbow	

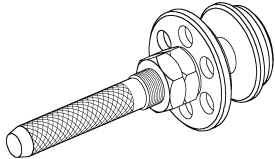

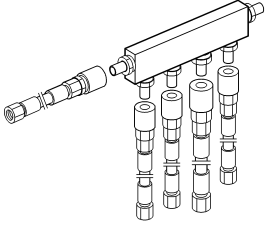
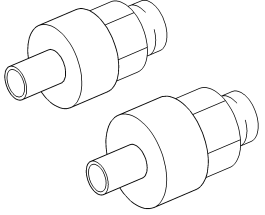
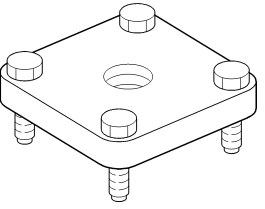
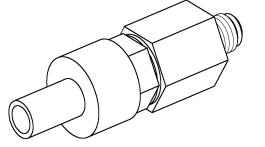
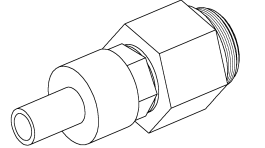
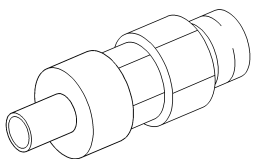
Oz	Sach-Nr. Part Number	Benennung Designation	Stück Qty	Verwendung / Used for Abmessung / Size	Seite/Page 97 von/of 109
	F3 0379 297	EINSCHLAGDORN DRIVE MANDREL	1	für Dichtring Thermostatgehäuse for thermostat housing seal	

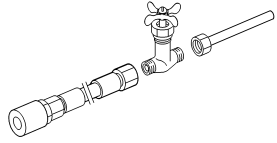
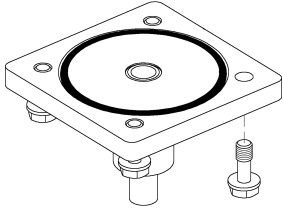
Oz	Sach-Nr. Part Number	Benennung Designation	Stück Qty	Verwendung / Used for Abmessung / Size	Seite/Page 98 von/of 109
	Y4 341 903	ABPRESSVORRICHTUNG PRESS. TESTING FIXT. <i>dazu / plus</i> +	1	Wasserabpressen ZB Motor for engine assembly	
	+ F6 558 540	ANSCHLUSSADAPTER TOOL SET	1	Wasser abpressen Wapu 536 200 11 01 und 536 201 00 31 SEED- SILA-Motor Pressure-test engine with water; water pump 536 200 11 01 and 5362010031 SEED-SILA engine	
	+ Y4 341 902	ABPRESSVORRICHTUNG PRESS. TESTING FIXT.	1	Wasserführungsgehäuse water housing	
	+ Y4 341 904	ANSCHLUSS-STUECK CONNECTOR	2	KG crankcase	
	+ Y4 341 905	ANSCHLUSS-STUECK CONNECTOR	2	Abgaskrümmter exhaust elbow	
	+ Y4 341 906	ANSCHLUSS-STUECK CONNECTOR	1	Wasserführungsgehäuse water housing	

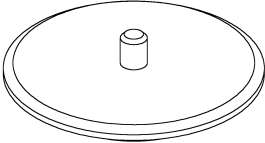
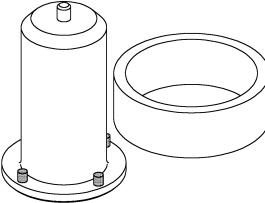
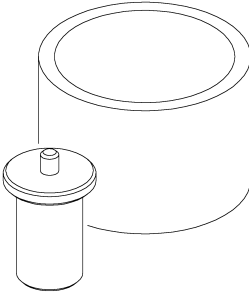
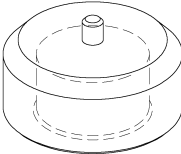
Oz	Sach-Nr. Part Number	Benennung Designation	Stück Qty	Verwendung / Used for Abmessung / Size	Seite/Page 99 von/of 109
	+ Y4 341 907	ENTLUEFTUNGSLEITUNG VENT LINE	1	Wasserführungsgehäuse water housing	
	+ Y4 343 679	ABPRESSVORRICHTUNG PRESS. TESTING FIXT.	2	f. Wapu. u. Thermostgeh. 12/16VG02 Motor for water pump + thermost. h. 12/16VG02 engine	

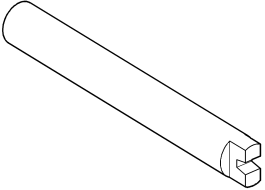
Oz	Sach-Nr. Part Number	Benennung Designation	Stück Qty	Verwendung / Used for Abmessung / Size	Seite/Page 100 von/of 109
	F3 0378 899	EINPRESSWERKZEUG INSTALLATION TOOL	1	für Lüfterantrieb G02- Motoren Wellendichtring 700 386 095 001 Assembly tools for fan drive, G02 engines for shaft seal 700 386 095 001	
	F6 558 547	EINPRESSVORRICHTUNG INSTALLATION JIG	1	für Lüfterantrieb G02-Motoren Assembly tools for fan drive, G02 engines	
	F6 559 660	AUSDRUECKWERKZEUG PRESS-OUT TOOL	1	Montagewz. für Lüfterantrieb G02- Motoren für Welle 522 206 00 07 Assembly tools for fan drive, G02 engines for shaft 522 206 00 07	
	F6 559 672	AUSDRUECKWERKZEUG PRESS-OUT TOOL	1	Montagewz. für Lüfterantrieb G02- Motoren für Lager Assembly tools for fan drive, G02 engines for bearing	

Oz	Sach-Nr. Part Number	Benennung Designation	Stück Qty	Verwendung / Used for Abmessung / Size	Seite/Page 101 von/of 109
	F6 555 753	AUSRICHTDORN ALIGNMENT MANDREL	1	Drehzahlgeber nur für SEED/SILA speed transmitter, only for SEED/SILA engines	

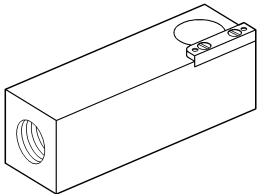
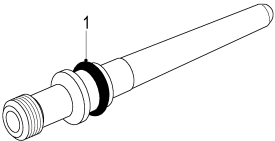
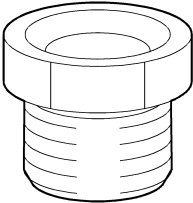
Oz	Sach-Nr. Part Number	Benennung Designation	Stück Qty	Verwendung / Used for Abmessung / Size	Seite/Page 102 von/of 109
	F3 0004 455	EINMAULSCHLUESSEL OPEN-END WRENCH	1	SW 65 für Auf- und Abpressvorrichtungen 65 A/F for installation/removal jigs	
	F3 0450 902	EINSTECKKNARRE RATCHET ADAPTER	1	3/4" , 14 X 18 Vierkant, ausgelegt für max. 1.400 Nm 3/4" sq. dr. 14 x 18, designed for max. 1400 Nm	
	Y4 342 008	PRUEFAUFNAHME SPECIMEN HOLDER <i>dazu / plus</i> +	1	zum E.-Düse prüfen for testing injector	
	+ 000 017 06 24	DRUCKROHRSTUTZEN PRESSURE PIPE NECK	1		
1	5419970645	DICHTRING SEALING RING	1		
	+ 541 017 00 71	DRUCKSCHRAUBE THRUST SCREW	1		

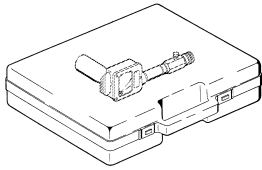
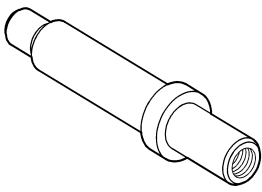
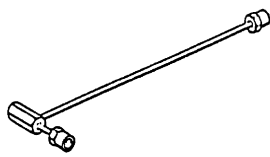
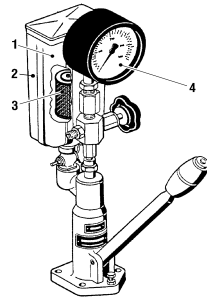

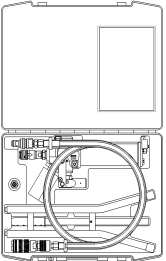
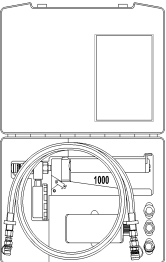
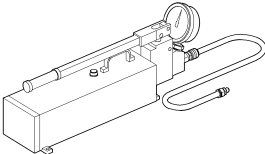
Oz	Sach-Nr. Part Number	Benennung Designation	Stück Qty	Verwendung / Used for Abmessung / Size	Seite/Page 103 von/of 109
	001 538 42 30	DREHMOMENTSCHLUESSEL TORQUE WRENCH	1	Anziehen der M3 Befestigungsschrauben elektr. Kabelanschluß Einspr.-Vent. 0010104251 0.5 - 5 Nm Tightening of M3 securing screws of electr. cable connection Injector 0010104251, 0.5 - 5 Nm	
	550 589 09 21/00	KOMPR.DRUCKSCHREIBER COMPRESSION PRESS RE <i>dazu / plus</i> +	1	10 - 60 bar Compression pressure gauge 10 - 60 bar	
	+ Y4 343 698	ANSCHLUSSSTUECK CONNECTING PIECE	1	f. Kompressionsdruck- Schreiber for compression tester	
	560 589 14 61/00	DRUCKLEITUNG PRESSURE LINE	1	zu Düsenprüfgerät to Nozzle Testing Unit	
	820 589 25 21/00	DUESENPRUEFGERAET NOZZLE TESTING UNIT	1	für Einspritzventile (Öffnungsdruck, Sprühbild, Dichtheitsprobe)	
1	8205895163/01	BRENNSTOFFBEHAELTER FUEL CONTAINER	1	for injection valves (opening pressure, spray pattern, leak test)	
2	8205895163/02	BECHERDECKEL BEAKER COVER	1		
3	8205895163/04	FILTER KOMPLETT FILTER COMPLETE	1		
4	0001530125/00	MANOMETER PRESS.GAUGE	1		

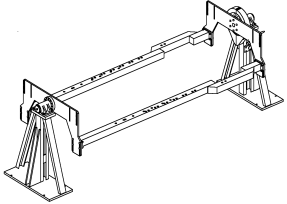
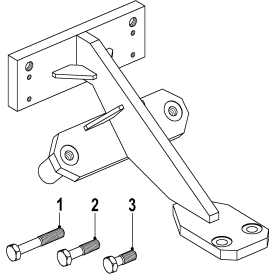
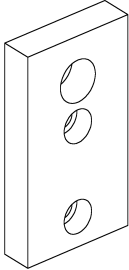
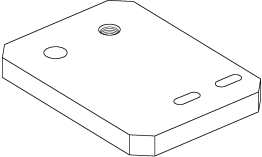
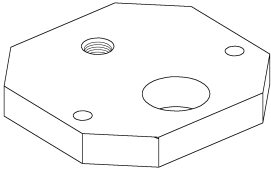
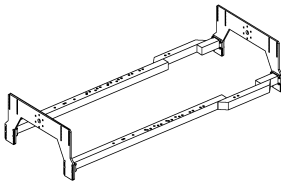
Oz	Sach-Nr. Part Number	Benennung Designation	Stück Qty	Verwendung / Used for Abmessung / Size	Seite/Page 104 von/of 109
	B8 0146 887	HANDPUMPENSATZ HAND PUMP SET	1	3000 bar, für Auf- und Abpresswerkzeuge 3000bar. For press-fit and removal tools.	
	B8 0146 893	HANDPUMPENSATZ HAND PUMP SET	1	1000 bar, für Auf- und Abpresswerkzeuge 1000bar. For press-fit and removal tools.	
	B8 0146 898	HANDPUMPE HAND PUMP	1	1000 bar, mit grossem Ölvolumen für Auf- und Abpresswerkzeuge 1000bar. With large oil volume for press-fit and removal tools.	 B80146898a

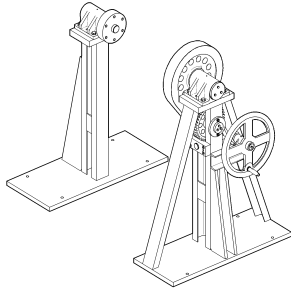
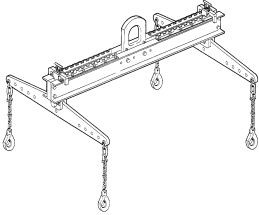
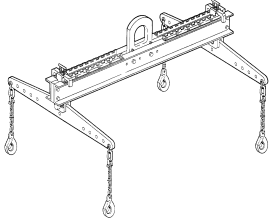
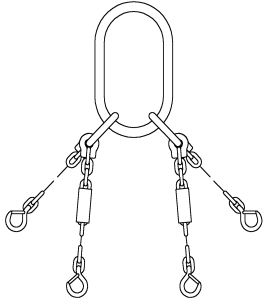
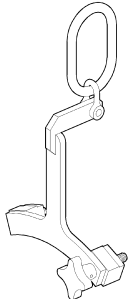
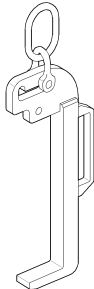
Oz	Sach-Nr. Part Number	Benennung Designation	Stück Qty	Verwendung / Used for Abmessung / Size	Seite/Page 105 von/of 109
	F6 554 681	ZB-SCHWENKBOCK SWIVEL BLOCK <i>besteht aus / consists of</i> ▶	1	für Kurbelgehäuse und ZB Motor for crankcase and engine complete	
	▶ F6 554 682	AUFNAHME MOUNT	4		
1	000933012094	SECHSKANTSCHRAUBE SCREW	2		
2	000931012033	SECHSKANTSCHRAUBE SCREW	2		
3	000933012080	SECHSKANTSCHRAUBE SCREW	2		
	▶ F6 554 683	DISTANZPLATTE SPACER PLATE	2		
	▶ F6 554 684	AUFNAHME MOUNT	2		
	▶ F6 554 685	AUFNAHME MOUNT	2		
	▶ F6 554 710	RAHMEN FRAME	1		

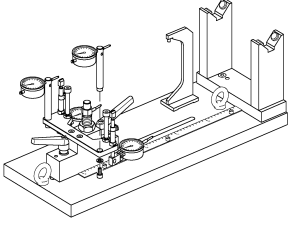
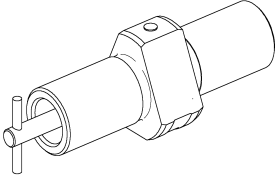
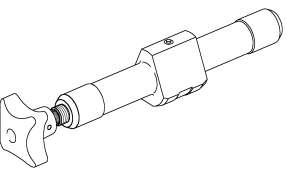
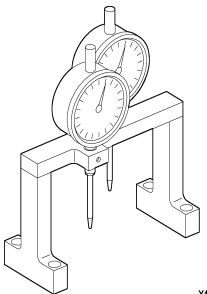

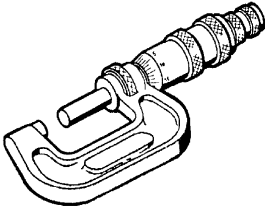
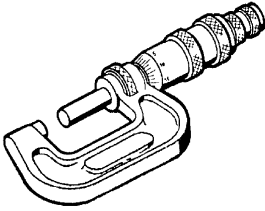
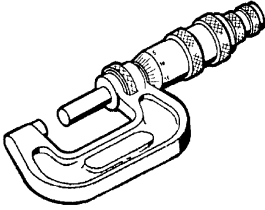
Oz	Sach-Nr. Part Number	Benennung Designation	Stück Qty	Verwendung / Used for Abmessung / Size	Seite/Page 106 von/of 109
	▶ VM59210	SCHWENKBOCK SWIVEL STAND	1		
	T8 0090 170	HEBEZEUG HOIST	1	für SEED-SILA- Motor, 12/18V G02 Motoren 6000 KG for SEED-SILA engine, 12/16V G02 engines, 6000 KG	
	T8 0090 376	KETTENTRAVERSE CHAIN BEAM	1	für ZB Motor 8V-16V mit angefl. Getriebe, 8500 KG for assy. engine 8V-16V with flange-mounted gearbox, 8500 KG	
	T8 0091 022	HAKENKETTE HOOK CHAINE	1	Marine-Motor mit 4-Punktaufhängung anheben to lift marine engine with 4-point mounting	
	T8 0091 190	TRAGBUEGEL MOUNTING BRACKET	1	8V/12V 2000M Schwungrad SAE1 531 030 11 05 an/abbauen 8/12V 2000 SAE 1 flywheel 531 030 11 05 □ installation/removal	
	T8 0091 765	TRAGBUEGEL LIFT HANDLE	1	Ölkühler an/abbauen for oil cooler removal/installation	

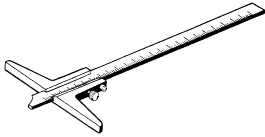
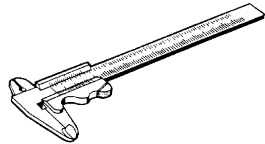
Oz	Sach-Nr. Part Number	Benennung Designation	Stück Qty	Verwendung / Used for Abmessung / Size	Seite/Page 107 von/of 109
	Y2 0097 353	ENDOSKOP,KOMPLETT RIGID BOROSCOPE	1	6x455mm mit Zubehör 6x455mm with accessories	
	Y4 341 492	PRUEFVORRICHTUNG TEST JIG <i>dazu / plus</i> +	1	Parallelität und Verschränkung der Pleuel prüfen Check parallelism and twist of conrod	
	+ Y4 341 915	PRUEFDORN TEST MANDREL	1		
	+ Y4 341 916	PRUEFDORN TEST MANDREL	1		
	Y4 343 695	MESSVORRICHTUNG MEASURING FIXTURE	1	Prüfen der Steuerzeiten To check valve timing	 <small>Y4343695a</small>

Oz	Sach-Nr. Part Number	Benennung Designation	Stück Qty	Verwendung / Used for Abmessung / Size	Seite/Page 108 von/of 109
	Y2 0000 085	BUEGELMESSSCHRAUBE MICROMETER 125-150	1	125 - 150 mm 125 - 150 mm	
	Y2 0000 088	BUEGELMESSSCHRAUBE MICROMETER 50-75	1	50 - 75 mm 50 - 75 mm	
	Y2 0000 169	BUEGELMESSSCHRAUBE MICROMETER 75-100	1	75 - 100 mm 75 - 100 mm	
	Y2 0000 665	EINSTELLRING SETTING RING 9 MM	1	Einstellen des Innenmessgerätes Adjusting the inside- measuring device	
	Y2 0000 918	TIEFENMASS M. HAKEN DEPTH GAUGE 200 MM	1	200mm 200mm	
	Y2 0001 743	MESSSCHIEBER CALIPERS	1	160 mm 160mm	

Series 2000

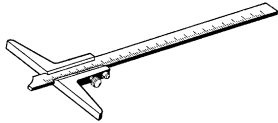
Messwerkzeuge / Measuring Tools

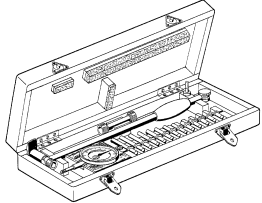
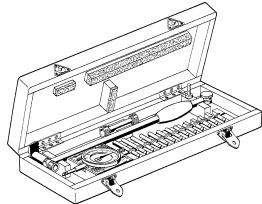
Oz	Sach-Nr. Part Number	Benennung Designation	Stück Qty	Verwendung / Used for Abmessung / Size	Seite/Page 109 von/of 109
	Y2 0002 779	TIEFENMASS M.HAKEN DEPTH GAUGE 500 MM	1	500 mm 500mm	
	Y2 0016 482	INNEN-FEINMESSGERAET INNER PRECS. MEAS.SE	1 R	8-12mm f. Ventilfehrung 8-12mm for valve guides	
	Y2 0091 481	INNENMESSGERAET BORE GAUGE 18/100	1	18-100mm (Pleuel) 18-100mm (conrod)	
	Y2 0091 482	INNENMESSGERAET BORE GAUGE 100/160	1	100-160mm (Zylinderlaufbuchse) 100-160mm (cylinder liner)	
	Y2 0091 483	INNENMESSGERAET BORE GAUGE 160/280	1	160-280mm 160-280mm	