

Technical Documentation

Diesel Engine
20 V 4000 G22/G42/G62/G82

Operating Instructions
M01555/00E



Printed in Germany

© 2002 Copyright MTU Friedrichshafen GmbH

Diese Veröffentlichung einschließlich aller seiner Teile ist urheberrechtlich geschützt. Jede Verwertung oder Nutzung bedarf der vorherigen schriftlichen Zustimmung der MTU Friedrichshafen GmbH. Das gilt insbesondere für Vervielfältigung, Verbreitung, Bearbeitung, Übersetzung, Mikroverfilmungen und die Einspeicherung und / oder Verarbeitung in elektronischen Systemen, einschließlich Datenbanken und Online-Diensten.

Das Handbuch ist zur Vermeidung von Störungen oder Schäden beim Betrieb zu beachten und daher vom Betreiber dem jeweiligen Wartungs- und Bedienungspersonal zur Verfügung zu stellen.

Änderungen bleiben vorbehalten.

Printed in Germany

© 2002 Copyright MTU Friedrichshafen GmbH

This Publication is protected by copyright and may not be used in any way whether in whole or in part without the prior written permission of MTU Friedrichshafen GmbH. This restriction also applies to copyright, distribution, translation, microfilming and storage or processing on electronic systems including data bases and online services.

This handbook is provided for use by maintenance and operating personnel in order to avoid malfunctions or damage during operation.

Subject to alterations and amendments.

Imprimé en Allemagne

© 2002 Copyright MTU Friedrichshafen GmbH

Tout droit réservé pour cet ouvrage dans son intégralité. Toute utilisation ou exploitation requiert au préalable l'accord écrit de MTU Friedrichshafen GmbH. Ceci s'applique notamment à la reproduction, la diffusion, la modification, la traduction, l'archivage sur microfiches, la mémorisation et / ou le traitement sur des systèmes électroniques, y compris les bases de données et les services en ligne.

Le manuel devra être observé en vue d'éviter des incidents ou des endommagements pendant le service. Aussi recommandons-nous à l'exploitant de le mettre à la disposition du personnel chargé de l'entretien et de la conduite.

Modifications réservées.

Impreso en Alemania

© 2002 Copyright MTU Friedrichshafen GmbH

Esta publicación se encuentra protegida, en toda su extensión, por los derechos de autor. Cualquier utilización de la misma, así como su reproducción, difusión, transformación, traducción, microfilmación, grabación y/o procesamiento en sistemas electrónicos, entre los que se incluyen bancos de datos y servicios en línea, precisa de la autorización previa de MTU Friedrichshafen GmbH.

El manual debe tenerse presente para evitar fallos o daños durante el servicio, y, por dicho motivo, el usuario debe ponerlo a disposición del personal de mantenimiento y de servicio.

Nos reservamos el derecho de introducir modificaciones.

Stampato in Germania

© 2002 Copyright MTU Friedrichshafen GmbH

Questa pubblicazione è protetta dal diritto d'autore in tutte le sue parti. Ciascun impiego od utilizzo, con particolare riguardo alla riproduzione, alla diffusione, alla modifica, alla traduzione, all'archiviazione in microfilm ed alla memorizzazione od all'elaborazione in sistemi elettronici, comprese banche dati e servizi on line, deve essere espressamente autorizzato per iscritto dalla MTU Friedrichshafen GmbH.

Il manuale va consultato per evitare anomalie o guasti durante il servizio, per cui va messo a disposizione dall'utente al personale addetto alla manutenzione e alla condotta.

Con riserva di modifiche.

Printed in Germany

© 2002 Copyright MTU Friedrichshafen GmbH

A presente publicação, inclusive todas as suas partes, está protegida pelo direito autoral. Qualquer aproveitamento ou uso exige a autorização prévia e por escrito da MTU Friedrichshafen GmbH.

Isto diz respeito em particular à reprodução, divulgação, tratamento, tradução, microfilmagem, e a memorização e/ou processamento em sistemas eletrônicos, inclusive bancos de dados e serviços on-line.

Para evitar falhas ou danos durante a operação, os dizeres do manual devem ser respeitados. Quem explora o equipamento economicamente consequentemente deve colocá-lo à disposição do respetivo pessoal da conservação, e à disposição dos operadores.

Salvo alterações.

1 Safety

Safety, accident prevention and environmental protection instructions

2 Product Summary

Engine summary, technical data

3 Operation

Task descriptions

4 Maintenance and Servicing

Maintenance schedule

5 Troubleshooting

Malfunctions, causes, measures

6 Task Description

Inspection and maintenance tasks

7 Annex

Abbreviations

Index

Wichtig - Important - Importante

Bitte die Karte „Inbetriebnahmemeldung“ abtrennen und ausgefüllt an MTU Friedrichshafen GmbH zurücksenden.

Die Informationen der Inbetriebnahmemeldung sind Grundlage für den vertraglich vereinbarten Logistik-Support (Gewährleistung, Ersatzteile etc.).

Please complete and return the “Commissioning Note” card below to MTU Friedrichshafen GmbH.

The Commissioning Note information serves as a basis for the contractually agreed logistic support (warranty, spare parts, etc.).

Veillez séparer la carte “Signalisation de mise en service” et la renvoyer à la MTU Friedrichshafen GmbH.

Les informations concernant la signalisation de mise en service constituent la base pour l'assistance en exploitation contractuelle (garantie, rechanges, etc.).

Rogamos separen la tarjeta “Aviso de puesta en servicio” y la devuelvan rellena a MTU Friedrichshafen GmbH.

Las informaciones respecto al aviso de puesta en servicio constituyen la base para el soporte logístico contractual (garantía, piezas de repuesto, etc.).

Staccare “Avviso di messa in servizio” e rispedito debitamente compilato alla MTU Friedrichshafen GmbH.

Le informazioni ivi registrate sono la base per il supporto logistico contrattuale (garanzia, ricambi, ecc.).

Postcard

MTU Friedrichshafen GmbH
Department SCSD
88040 Friedrichshafen
GERMANY



Bitte in Blockschrift ausfüllen!
Please use block capitals!
Prière de remplir en lettres capitales!
¡A rellenar en letras de imprenta!
Scrivere in stampatello!



Motornr.: Engine No.: No du moteur: No de motor: Motore N.:	Auftragsnr.: MTU works order No.: No de commande: No de pedido: N. commessa:
Motortyp: Engine model: Type du moteur: Tipo de motor: Motore tipo:	Inbetriebnahmedatum: Date put into operation: Mise en service le: Fecha de puesta en servicio: Messa in servizio il:
Eingebaut in: Installation site: Lieu de montage: Lugar de montaje: Installato:	Schiffstyp / Schiffshersteller: Vessel/type/class / Shipyard: Type du bateau / Constructeur: Tipo de bugue / Constructor: Tipo di Barca / Costruttore:
Endabnehmer/Anschrift: End user's address: Adresse du client final: Dirección del cliente final: Indirizzo del cliente finale:	
Bemerkung: Remarks: Remarques: Observaciones: Commento:	

Inbetriebnahmemeldung

Commissioning Note

Notice de mise en service

Aviso de puesta en servicio

Avviso di messa in servizio

Safety, Accident Prevention and Environmental Protection Instructions

These instructions must be read and followed by every person involved in operation, maintenance or transportation of the machinery plant.

General

In addition to the instructions in this publication, the applicable country-specific legislation and other compulsory regulations regarding accident prevention must be observed.

This engine is a state-of-the art product and conforms with all applicable specifications and regulations. Nevertheless, persons and property may be at risk in the event of:

- Incorrect use
- Operation, maintenance and repair by unqualified personnel
- Modifications or conversions
- Non-compliance with the Safety Instructions

Correct use

The engine is intended exclusively for the application specified in the contract or defined at the time of delivery. Any other use is considered improper use. The manufacturer will accept no liability for any resultant damage. The responsibility is borne by the user alone.

Correct use also includes observation of and compliance with the maintenance specifications.

Personnel requirements

Work on the engine must only be carried out by properly qualified and instructed personnel.

The specified legal minimum age must be observed.

Responsibilities of the operating, maintenance and repair personnel must be specified.

Modifications or conversions

Modifications made by the customer to the engine may affect safety.

MTU will accept no liability or warranty claims for any damage caused by unauthorized modifications or conversions.

Organizational measures

This publication must be issued to all personnel involved in operation, maintenance, repair or transportation.

It must be kept at hand near the engine and accessible at any time to all personnel involved in operation, maintenance, repair or transportation.

The personnel must be instructed on engine operation and repair by means of this publication, and in particular the safety instructions must be explained.

This is especially important for personnel who work on the engine only on an occasional basis. Such personnel must be given instructions repeatedly.

Spare parts

Only genuine MTU spare parts must be used to replace components or assemblies. In the event of any damage caused by the use of other spare parts, no liability nor warranty claims vis-à-vis the engine manufacturer will be accepted.

Working clothes and protective equipment

Wear proper work clothing for all work.

Depending on the kind of work, use additional protective equipment, e.g. protective goggles, gloves, helmet, apron.

Work clothing must be tight fitting so that it does not catch on rotating or projecting components.

Do not wear jewelry (e.g. rings, chains etc.).

Transportation

Lift the engine only with the lifting eyes provided.

Use only the transport and lifting equipment approved by MTU.

Take note of the engine center of gravity.

Transport the engine only in the installation position.

In the case of special packaging with aluminum foil, suspend the engine on the lifting eyes of the transport pallet or transport with equipment for heavy loads (forklift truck).

Prior to transporting the engine, it is imperative to install transportation locking devices for crankshaft and engine mounts.

Secure the engine against tilting during transportation. The engine must be especially secured against slipping or tilting when going up or down inclines and ramps.

Setting the engine down after transportation

Place the engine only on an even, firm surface.

Ensure appropriate consistency and load-bearing capacity of the ground or support surface.

Never place an engine on the oil pan, unless expressly authorized by MTU on a case-to-case basis to do so.

Working with laser equipment

When working with laser equipment, always wear special laser-protection goggles.

Laser equipment can generate extremely intensive, concentrated radiation by the effect of stimulated emission in the range of visible light or in the infrared or ultraviolet spectral range. The photochemical, thermal and optomechanical effects of the laser can cause damage. The main danger is irreparable damage to the eyes.

Laser equipment must be fitted with the protective devices necessary for safe operation according to type and application.

For conducting light-beam procedures and measurement work, only the following laser devices must be used:

- Laser devices of classes 1, 2 or 3A,
- Laser devices of class 3B, which have maximum output in the visible wavelength range (400 to 700 nm), a maximum output of 5 mW, and in which the beam axis and surface are designed to prevent any risk to the eyes.

Engine operation

When the engine is running, always wear ear protectors.

Ensure that the engine room is well ventilated.

Mop up any leaked or spilt fluids and lubricants immediately or soak up with a suitable bonding agent.

Exhaust gases from combustion engines are poisonous. Inhalation of poisonous exhaust gases is a health hazard. The exhaust pipework must be free of leaks and discharge the gases to atmosphere.

During engine operation, do not touch battery terminals, generator terminals or cables.

Inadequate protection of electrical components can lead to electric shocks and serious injuries.

When the engine is running, never release coolant, oil, fuel, compressed-air or hydraulic lines.

Maintenance and repair

Compliance with maintenance and repair specifications is an important safety factor.

Unless expressly permitted, no maintenance or repair work is to be carried out with the engine running. Ensure the engine cannot be started unintentionally. On engines equipped with electrical starter, disconnect the starter battery. On engines equipped with air starter, close the shut-off valve of the compressed-air system and vent the compressed-air line. Fit the warning label "Do not operate" either in the operator's room or on the control equipment! Persons not involved must keep clear.

Never attempt to rectify faults or carry out repairs if you do not have the necessary experience or special tools required. Maintenance and repair work must only be carried out by authorized, qualified personnel.

Use only proper, calibrated tools.

Do not work on engines or components which are only held by lifting equipment or crane. Always support these components in accordance with regulations on suitable frames or stands before beginning any maintenance or repair work.

Before barring the engine, make sure that nobody is standing in the danger zone. After working on the engine, check that all guards have been reinstalled and that all tools and loose components have been removed from the engine.

Fluids emerging under high pressure can penetrate clothing and skin and may cause serious injury. Before starting work, relieve pressure in systems and H.P. lines which are to be opened.

Never bend a fuel line and do not install bent lines. Keep fuel injection lines and connections clean. Always seal connections with caps or covers if a line is removed or opened.

During maintenance and repair work, take care not to damage the fuel lines. To tighten the connections when installing the lines, use the correct tightening torque and ensure that all retainers and dampers are installed correctly.

Ensure that all fuel injection lines and pressurized oil lines have sufficient distance to other components to avoid contact with them. Do not place fuel or oil lines near hot components, except when necessary for design reasons during installation.

Elastomers (e.g. "Viton" sealing rings) are stable under normal operating conditions. When subjected to fire or temperatures above 300 °C the material degenerates, giving off hydrogen fluoride gas. The resulting acid leads to serious burning if it contacts the skin. Do not touch elastomeric seals if they have carbonized or resinous appearance. Wear protective gloves!

Take care with hot fluids in lines, pipes and chambers ⇒ Risk of injury!

Note cooling period for components which are heated for installation or removal Risk of injury!

Do not touch hot parts of the compressor and the exhaust system ⇒ Risk of injury!

Take special care when removing ventilation or plugs from engine. In order to avoid discharge of highly pressurized liquids, hold a cloth over the screw or plug. It is even more dangerous if the engine has recently been shut down, as the liquids can still be hot.

Take special care when draining hot fluids. ⇒ Risk of injury!

When draining, collect fluids in a suitable container, mop up any spilt fluids or wipe or soak them with a suitable bonding agent.

When changing the engine oil or working on the fuel system, ensure that the engine room is adequately ventilated.

When working high on the engine, always use suitable ladders and work platforms. Make sure components are placed on stable surfaces.

In order to prevent back injuries when lifting heavy components adults, depending on age and sex, should only lift weights between max. 10 kg and 30 kg, therefore:

- Use lifting gear or seek assistance.
- Ensure that all chains, hooks, slings, etc. are tested and authorized, are sufficiently strong and that hooks are correctly positioned. Lifting eyes must not be unevenly loaded.

Welding work

Never carry out welding work on the engine or engine-mounted units.

Never use the engine as a ground connection. (This prevents the welding current passing through the engine and causing scoring or burning at bearings, sliding surfaces and tooth flanks, which can lead to pitting or other material damage).

Never position the welding power supply cable adjacent to, or crossing MTU plant wiring harnesses. (The welding current could be induced in the cable harnesses and could possibly damage the electrical plant).

The welding unit ground connection must not be more than 60 cm from the weld point.

If components (e.g. exhaust manifold) are to be welded, they must be removed from the engine.

It is not necessary to remove the connector and the connections when carrying out welding operation on MTU electronics if the master switch for power supply is switched from "ON" to "OFF" and the wire is disconnected from the negative and positive poles on the battery.

Hydraulic installation and removal

Only the hydraulic installation and removal equipment specified in the work schedule and in the assembly instructions must be used.

The max. permissible push-on pressure specified for the equipment must not be exceeded.

The H.P. lines for hydraulic installation and removal are tested with 3800 bar.

Do not attempt to bend or apply force to lines.

Before starting work, pay attention to the following:

- Vent the hydraulic installation/removal tool, the pumps and the lines at the relevant points for the system to be used (e.g. open vent plugs, pump until bubble-free air emerges, close vent plugs).
- For hydraulic installation, screw on the tool with the piston retracted.
- For hydraulic removal, screw on the tool with the piston extended.

For a hydraulic installation/removal tool with central expansion pressure supply, screw spindle into shaft end until correct sealing is achieved.

During hydraulic installation and removal, ensure that nobody is standing in the immediate vicinity of the component to be installed/removed. As long as the system is under pressure, there is the risk that the component to be installed/removed may be suddenly released from the pressure connection.

Before use, the tools must be checked at regular intervals (crack test).

Working on electrical/electronic assemblies

Authorization must be obtained from the superior prior to commencing maintenance and repair work and switching off parts of the electronic system required for this.

Prior to working on assemblies, the power of the appropriate areas must be switched off. Any measures requiring power supply are expressly defined as such at the appropriate place in the manual.

Gases released from the battery are explosive. Avoid sparks and naked flames. Do not allow battery acids to come in contact with skin or clothing. Wear protective goggles. Do not place tools on the battery. Before connecting the cable to the battery, check battery polarity. Battery pole reversal may lead to injury through the sudden discharge of acid or bursting of the battery body.

Do not damage wiring during removal work and when reinstalling wiring and ensure that during operation it is not damaged by contact with sharp objects, by rubbing against other component or by a hot surface.

Do not secure wiring to fluid-carrying lines.

On completion of the maintenance and repair work, any cables which have become loose must be correctly connected and secured.

Always tighten connectors with connector pliers.

On completion of all repair work, the component and system must be subjected to a function check. Separate testing of the repaired component without system integration is insufficient.

If wires are installed beside mechanical components and there is a risk of chafing, use cable clamps to properly support the wires.

For this purpose, no cable binders must be used as, during maintenance and / or repair work, the binders can be removed but not installed a second time.

Spare parts shall be properly stored prior to replacement, i.e. particularly protected against moisture. Defective electronic components and assemblies must be suitably packed when dispatched for repair, i.e. particularly protected against moisture and impact and wrapped in antistatic foil if necessary.

Operation of electrical equipment

When operating electrical equipment, certain components of this equipment are live.

Noncompliance with the warning instructions given for this equipment may result in serious injury or damage to property.

Fire prevention

Rectify any fuel or oil leaks immediately; even splashes of oil or fuel on hot components can cause fires - therefore always keep the engine in a clean condition. Do not leave cloths soaked with fluids and lubricants lying around on the engine. Do not store combustible fluids near the engine.

Do not weld pipes and components carrying oil or fuel. Before welding, clean with an inflammable fluid.

When starting the engine with a foreign power source, connect the ground lead last and remove it first. To avoid sparks in the vicinity of the battery, connect the ground lead from the foreign power source to the ground lead of the engine or to the ground terminal of the starter.

Always keep suitable fire-fighting equipment (fire extinguishers) at hand and familiarize yourself with their use.

Noise

Noise can lead to an increased risk of accident if acoustic signals, warning shouts or noises indicating danger are drowned.

At all workplaces with a sound pressure level over 85 dB(A), always wear ear protectors (protective wadding, plugs or capsules).

Environmental protection

Dispose of used fluids, lubricants and filters in accordance with local regulations.

Manipulation of the injection control system can influence the engine performance and exhaust emissions. As a result, compliance with environmental regulations may no longer be guaranteed.

Only fuels of the specified quality required to achieve emission limits must be used.

In Germany, the VAWS (= regulations governing the use of materials that may affect water quality) is applicable, which means work must only be carried out by authorized specialist companies (MTU is such a company).

Auxiliary materials

Use only fluids and lubricants that have been tested and approved by MTU.

Fluids and lubricants must be kept in suitable, properly designated containers. When using fluids, lubricants and other chemical substances, follow the safety instructions applicable to the product. Take care when handling hot, chilled or caustic materials. When using inflammable materials, avoid sparks and do not smoke.

⇒ **Lead**

When working with lead or lead-containing pastes, avoid direct contact to the skin and do not inhale lead vapors.

Adopt suitable measures to avoid the formation of lead dust!

Switch on fume extraction system.

After coming into contact with lead or lead-containing materials, wash hands!

⇒ **Acids and alkaline solutions**

When working with acids and alkalis, wear protective goggles or face mask, gloves and protective clothing.

Immediately remove clothing wetted by acids and alkalis!

Rinse injuries with plenty of water!

Rinse eyes immediately with eyedrops or clean tap water.

⇒ **Painting**

When painting in other than spray booths equipped with extractors, ensure good ventilation. Make sure that adjacent work areas are not affected.

It is absolutely necessary to wear masks providing protection against paint and solvent fumes.

Observe fire prevention regulations!

No smoking.

No naked flame!

⇒ **Liquid oxygen**

Liquid oxygen is highly inflammable.

Liquid oxygen should only be stored in small quantities and in regulation containers (without fixed seals)! Do not bring liquid oxygen in contact with the body (hands), as this causes frostbite and possibly the loss of tissue.

No smoking, no naked flame (risk of explosion)! Excessive oxygen in the air leads to explosive combustion.

Do not store combustible substances (e.g. oils and greases) within 5 m of the working area!

Under no circumstances should clothing be oily or greasy.

Do not allow vapors to penetrate clothing! Oxygen enrichment in fabric can cause working clothes to ignite suddenly!

After working with liquid oxygen, do not smoke until clothing is free of vapors!

Avoid all knocks and jars to the containers, fixtures or workpieces.

⇒ Liquid nitrogen

Store liquid nitrogen only in small quantities and always in regulation containers without fixed covers.

Do not bring liquid nitrogen in contact with the body (eyes, hands), as this causes frostbite and numbing.

Protective clothing (including gloves and closed shoes) and protective goggles!

Ensure the room is well ventilated (88% contamination of breathing with nitrogen will result in suffocation).

Avoid all knocks and jars to the containers, fixtures or workpieces.

⇒ Compressed air

Compressed air is air compressed at excess pressure and is stored in tanks from which it can be extracted.

The pressure at which the air is kept can be read off at pressure gauges which must be connected to the compressed air tanks and the compressed air lines.

When working with compressed air, safety precautions must be constantly observed:

- Pay special attention to the pressure level in the compressed air network and pressure vessel!
- Connecting devices and equipment must either be designed for this pressure or, if the permitted pressure for the connecting elements is lower than the pressure required, a pressure reducing valve and safety valve (set to permitted pressure) must form an intermediate connection. Hose coupling and connections must be securely attached!
- Always wear protective goggles when blowing off tools or extracting chips!
- The snout of the air nozzle is provided with a protective disc (e.g. rubber disc), which prevents air-borne particles being reflected and thereby prevents injury to eyes.
- First shut off compressed air lines before compressed air equipment is disconnected from the supply line or before equipment or tool is to be replaced!
- Unauthorized use of compressed air, e.g. forcing flammable liquids (danger class A1, A11 and B) out of containers, results in a risk of explosion!
- Forcing compressed air into thin-walled containers (e.g. containers made of tin, plastic and glass) for drying purposes or to check for leaks, results in a risk of explosion!
- Do not blow dirty clothing with compressed air when being worn on the body.
Even compressed air at low pressure penetrates clothing and, if the jet is directed at the back, the air can enter the anal cavity and fatally rupture the intestines!

⇒ Used oil

Used oil may contain health-threatening combustion residues.

Rub barrier cream into hands!

Wash hands after contact with used oil.

Warning signs

Before putting the engine into service and before working on the engine, read and follow all warning signs. Do not paint on warning signs. Replace illegible signs.

Warning notices

This Publication contains especially emphasized safety instructions in accordance with the American standard ANSI Z535, which begin with one of the following signal words according to the degree of danger:

 DANGER	In event of immediate danger. Consequences: Death or serious injury.
--	---

 WARNING	In event of dangerous situations. Consequences: Death or serious injury.
---	---

 CAUTION	In event of dangerous situations. Consequences: Slight injury or material damage
---	---

In these cases, take special care.

Read and become acquainted with all cautions and symbols before operating or repairing this product.

Pass on all safety instructions to your operating, maintenance, repair and transport personnel!

Engine layout

Illustration is valid for 20V 4000 G22/42/62/82 engines

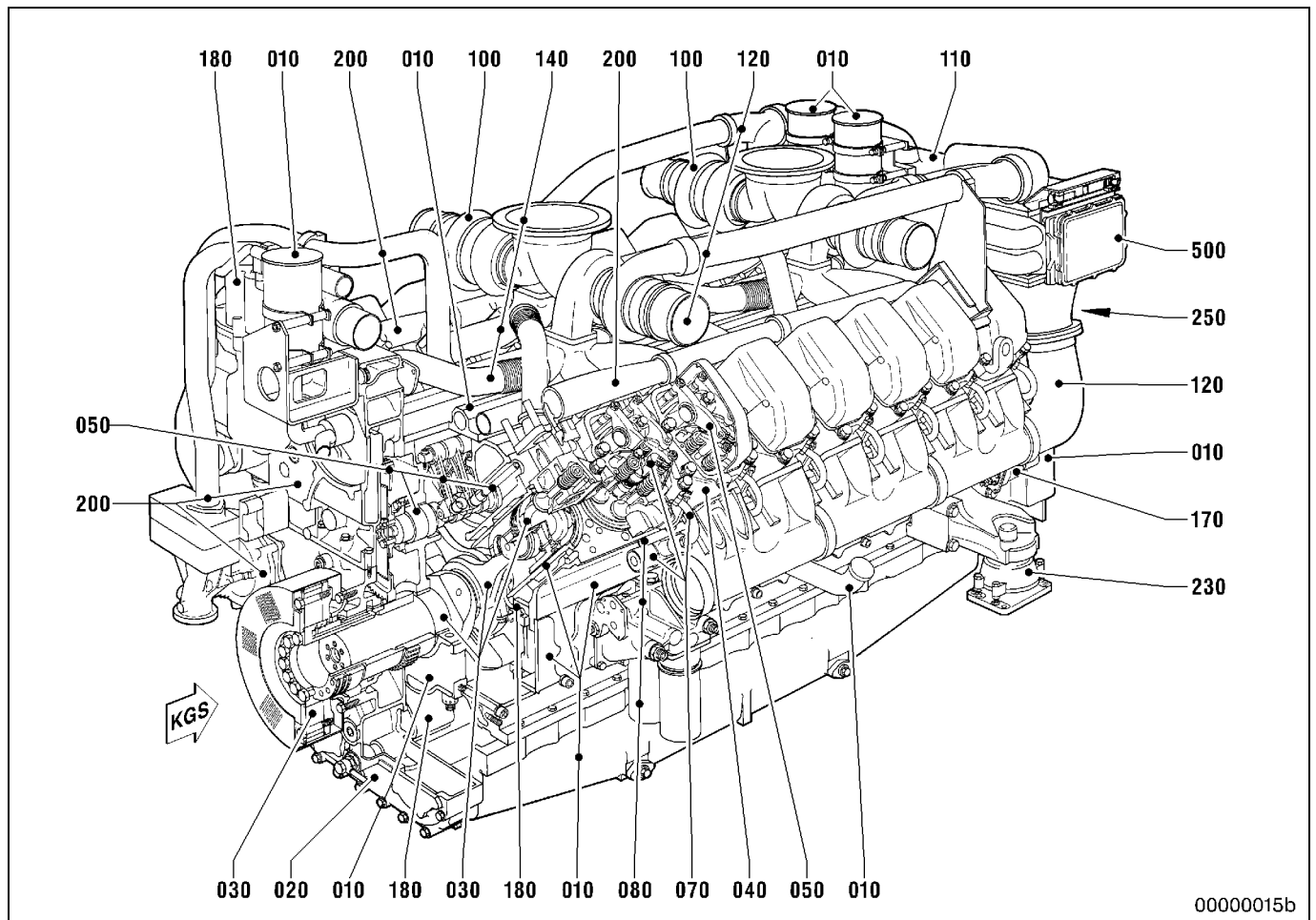

00000015b

010	Crankcase and externally mounted components	140	Exhaust system
020	Gear train	170	Starting system
030	Running gear	180	Lube oil system
040	Cylinder head	200	Cooling system
050	Valve gear	210	Power supply
070	Fuel system (high pressure)	230	Mounting / support
080	Fuel system (low pressure)	250	PTO systems, driving end and free end
100	Exhaust turbocharger	500	Monitoring, control and regulation system, general electr. equipment
110	Intercooler		
120	Air intake / air supply		

Engine model designation

Key to the engine model designations 20V 4000 Gxy

20	=	Number of cylinders
V	=	Cylinder configuration: V engine
4000	=	Series
Gx	=	Application segment (x = 2, 4, 6, 8)
Y	=	Design index (y = 2 ...)

Engine side and cylinder designations

Engine sides are always designated as viewed from the driving end (KS).

The cylinders of the left engine side are designated "A" and those of the right side "B" (as per DIN ISO 1204).

The cylinders of each bank are numbered consecutively, starting with No. 1 at the driving end.

The numbering of engine components is also from the driving end, starting with No. 1.

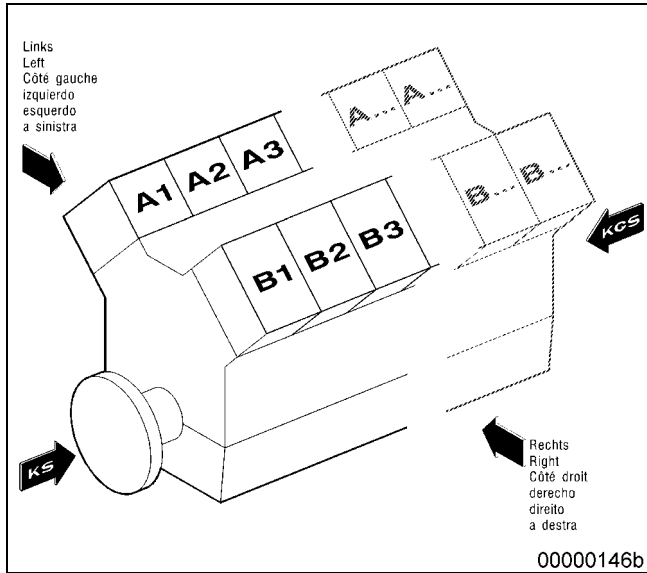

Applicable designations and abbreviations

Driving end = KS

Free end = KGS

Left side

Right side

Main engine dimensions

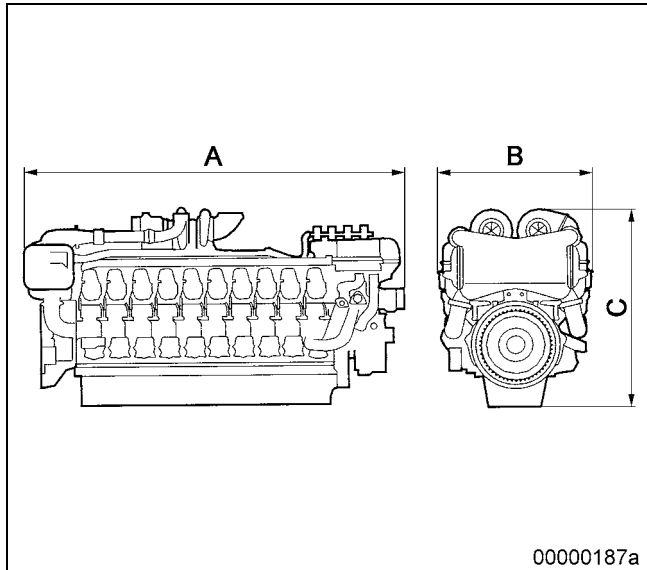

Engine model	Overall length (A)	Overall width (B)	Overall height (C)
20V 4000 G22/G42/ G62/G82	approx. 3520 mm	approx. 1460 mm	approx. 2040 mm

Engine weight

Engine model	Engine dry weight
20V 4000 G22/G42/G62/G82	approx. 9450 kg

Engine transport

20V 4000 G

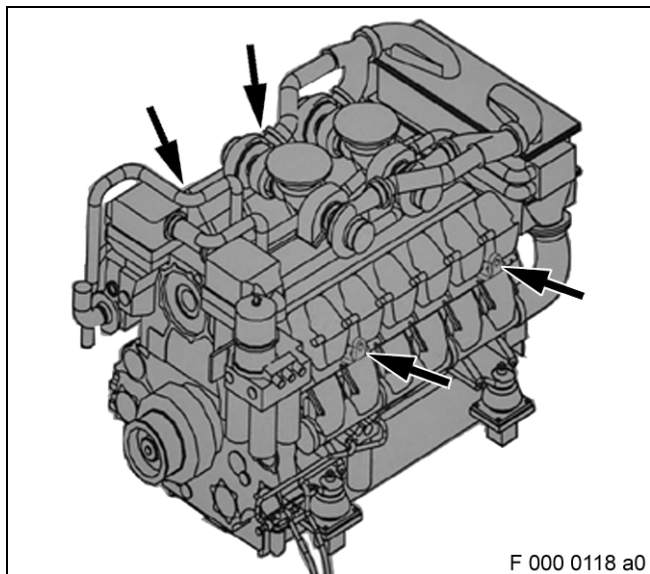

Use only the transport and lifting equipment approved by MTU.

Transport the engine only in the installation position.

Lift only the engine by the lifting eyes provided.

Lifting eyes are designed only for the weight of the engine.

For further transportation instructions, see chapter Safety.

Basic data - engines for stationary power supply

20V 4000 G22/42/62/82

Basic Design

- 20 cylinders
- 90° V cylinder arrangement
- Four-stroke diesel
- Liquid cooling
- Direct fuel injection
- Turbocharging with charge-air cooling
- Wet, replaceable cylinder liners
- Piston cooling
- 2 inlet valves, 2 exhaust valves per cylinder
- Dry exhaust manifolds
- Electronically controlled "Common Rail" fuel injection system
- Electronic engine management
- Bore 165 mm
- Stroke 210 mm
- Cylinder displacement 4.49 lit.
- Total displacement 89.8 lit.
- Compression ratio 15.5 : 1
- Direction of rotation CCW
(facing driving end)
- Firing order A1-B5-A8-B7-A5-B2-A7-B10-A2-B3-
A10-B6-A3-B4-A6-B9-A4-B1-A9-B8
- Final compression pressure at 120 rpm 24 bar to 28 bar
- Firing speed at 40°C engine coolant temperature approx. 100 to 120 rpm
- Flywheel housing/flywheel SAE 00/21"
- Cold start capability: air temperature 5 °C
(w/o start assistance, w/o coolant preheating)

Stationary power supply with liquid-cooled charge-air cooling - Engine power

Application group	Standby operation 3D	Continuous operation with limited operating time 3C	Continuous operation at variable load 3B	Continuous operation, unrestricted 3A
Operating mode	Standby power at variable load	Standby power at variable load	Prime power at variable load	Prime power at 100% load
Load factor	< 85 %	< 75 %	< 75 %	≤ 100 %
Operating hours per year	max. 500	max. 1000	unrestricted	unrestricted
Power specification DIN ISO 3046	Fuel stop power (ICFN)	10 % overload capability (ICXN)	10 % overload capability (ICXN)	10 % overload capability (ICXN)

Engine model	kW at 1500 rpm (50 Hz)			
Optimizations ¹⁾	☒	☒ or ①	☒ or ①	☒
20V 4000 G22	2420	2200	2200	-
20V 4000 G62	2670	2420	2460	2000

Engine model	kW at 1800 rpm (60 Hz)			
Optimizations ¹⁾	②		②	②
20V 4000 G42	2740	-	2490	-
20V 4000 G82	3010	-	2740	2060

Reference conditions	Standard	Power available up to
Intake air temperature	25 °C	40 °C
Altitude above sea level	100 m	400 m
Charge-air coolant temperature	55 °C	55 °C
Fan power requirement not considered.		

1)

Optimizations	① Exhaust emission (TA-Luft) ② Exhaust emission (EPA)	☒ Fuel consumption
---------------	--	--------------------

Acoustics

Sound pressure level acc. to ISO 8528-10:

Engine model	Parameter	3D	3D	3C	3C
		Optimized fuel consumption	Optimized exhaust emission	Optimized fuel consumption	Optimized exhaust emission
20V 4000 G22	Engine surface noise dB(A)	approx. 126		approx. 125	approx. 125
	Exhaust noise, unsilenced dB(A)	approx. 128		approx. 127	approx. 128
20V 4000 G42	Engine surface noise dB(A)		approx. 126		
	Exhaust noise, unsilenced dB(A)		approx. 131		
20V 4000 G62	Engine surface noise dB(A)	approx. 126		approx. 126	approx. 125
	Exhaust noise, unsilenced dB(A)	approx. 129		approx. 128	approx. 129
20V 4000 G82	Engine surface noise dB(A)		approx. 127		
	Exhaust noise, unsilenced dB(A)		approx. 132		

Engine model	Parameter	3B	3B	3A	3A
		Optimized fuel consumption	Optimized exhaust emission	Optimized fuel consumption	Optimized exhaust emission
20V 4000 G22	Engine surface noise dB(A)	approx. 125	approx. 125		
	Exhaust noise, unsilenced dB(A)	approx. 127	approx. 128		
20V 4000 G42	Engine surface noise dB(A)		approx. 126		
	Exhaust noise, unsilenced dB(A)		approx. 129		
20V 4000 G62	Engine surface noise dB(A)	approx. 126	approx. 125		approx. 125
	Exhaust noise, unsilenced dB(A)	approx. 128	approx. 129		approx. 127
20V 4000 G82	Engine surface noise dB(A)		approx. 126		approx. 125
	Exhaust noise, unsilenced dB(A)		approx. 131		approx. 127

Operational data

The operational data of the engine acceptance-test protocol are binding reference values.

All data are referenced to the engine running at operating temperature and nominal load.

Please address any questions regarding the operational data to your MTU contact person, indicating the engine model and number.

High-temperature cooling system	Unit	Reference value	Limit value
Coolant temperature at engine outlet	°C	95	99
Pressure loss in the external cooling system, max. permissible	bar	--	0.7
Coolant preheating temperature	°C	> 40	--
Low-temperature cooling system			
Coolant temperature at intercooler inlet	°C	55	--
Pressure loss in the external cooling system, max. permissible	bar	--	0.7
Lube Oil System			
Lube oil operating temperature from/to 20V 4000 G22/G62	°C	85/95	--
Lube oil operating temperature from/to 20V 4000 G42/G82	°C	86/95	--
Lube oil operating pressure before engine	bar	6.0	4.0
Lube oil consumption after 100 operating hours, average *of fuel consumption with a run-in engine	%*	0.3	1.0
Fuel System			
Fuel pressure at engine supply connection, min.	bar	--	- 0.1
Fuel pressure at engine supply connection, max.	bar	--	+ 1.5
Boundary conditions (for maximum power)			
Intake air depression	mbar	25	50
Exhaust back pressure	mbar	30	50

Charge Air	Unit	Reference value			
		Optimized fuel consumption	Optimized exhaust emission		
			TA-Luft	EPA	
Charge-air pressure before cylinder	Application group 3D, 20V 4000 G22	bar ABS	3.0	--	--
	standby power 20V 4000 G42	bar ABS	--	--	3.2
	20V 4000 G62	bar ABS	3.3	--	--
	20V 4000 G82	bar ABS	--	--	3.3
Application group 3C, continuous power, limited operating time	20V 4000 G22	bar ABS	2.7	3.4	--
	20V 4000 G62	bar ABS	3.0	3.7	--
Application group 3B, continuous power at variable load	20V 4000 G22	bar ABS	2.7	3.4	--
	20V 4000 G42	bar ABS	--	--	2.9
	20V 4000 G62	bar ABS	3.0	3.7	--
	20V 4000 G82	bar ABS	--	--	3.2
Application group 3A, continuous power, unrestricted	20V 4000 G62	bar ABS	2.5	--	--
	20V 4000 G82	bar ABS	--	--	2.5

The engine is allowed to be operated at full power up to the specified limit values.

The reference values can approach the limit values due to changed boundary conditions, in case of faults or expiration of service life.

If limit values are exceeded, locate the cause and rectify.

Oil capacity

- Initial filling approx. 390 lit.
- Oil dipstick mark, "min." approx. 245 lit.
- Oil dipstick mark, "max." approx. 340 lit.

Coolant capacity

internal engine cooling system, without external cooling system

- Engine coolant approx. 205 lit.
- Charge-air coolant approx. 55 lit.

3 Operation

3.1	Putting the engine into operation after extended out-of-service periods (>3 months) . . .	3 – 1
3.2	Putting the engine into operation after scheduled out-of-service-period	3 – 2
3.3	Starting the engine in manual mode	3 – 2
3.4	Emergency start (override mode)	3 – 3
3.5	Operational checks	3 – 4
3.6	Stopping the engine in manual mode	3 – 5
3.7	Emergency stop	3 – 5
3.8	After stopping the engine – engine remains ready for operation	3 – 6
3.9	After stopping the engine – putting the engine out of service	3 – 6

3.1 Putting the engine into operation after extended out-of-service periods (>3 months)

Preconditions

- Engine is stopped and starting disabled.
- MTU Fluids and Lubricants Specification (A001061/..) is available.

Putting the engine into operation after extended out-of-service-periods (>3 months)

Item	Task
Engine	Depreserve (→ MTU Fluids and Lubricants Specification A001061/..).
Lube oil system	Check oil level (→ Page 6 – 35);
Fuel prefilter	Prime (→ Page 6 – 27).
Fuel prefilter, pressure gauge	Align adjustable pointer with position of pressure indicator (→ Page 6 – 23).
Fuel system	Vent (→ Page 6 – 21).
Cooling system	If engine is out of service for more than one year, change engine coolant (→ Page 6 – 41); Change charge-air coolant (→ Page 6 – 47).
Cooling system	Check engine coolant level (→ Page 6 – 42); Check charge-air coolant level (→ Page 6 – 48).
Cooling system	Preheat coolant with preheating unit.
ECU	Check plug-in connections (→ Page 6 – 57).
Monitoring equipment	Carry out lamp test (see manufacturer's documentation).
Engine/generator control system	Switch ON; Select operating mode, e.g. MANUAL OPERATION, AUTOMATIC OPERATION.

3.2 Putting the engine into operation after scheduled out-of-service-period

Preconditions

- Engine is stopped and starting disabled.

Putting the engine into operation

Item	Task
Lube oil system	Check oil level (→ Page 6 – 35);
Cooling system	Check engine coolant level (→ Page 6 – 42); Check charge-air coolant level (→ Page 6 – 48).
Cooling system	Preheat coolant with preheating unit.
Fuel prefilter	Drain (→ Page 6 – 24).
Monitoring equipment	Carry out lamp test (see manufacturer's documentation).
Engine/generator control system	Switch ON; Select operating mode, e.g. MANUAL OPERATION, AUTOMATIC OPERATION.

3.3 Starting the engine in manual mode

Preconditions

- Generator is not connected to network.
- External start interlock is not activated.

 DANGER	Unguarded rotating and moving engine components. Risk of serious injury — danger to life! <ul style="list-style-type: none"> • Before barring or starting the engine, ensure that nobody is in the danger zone.
--	--

 WARNING	Engine noise above 85 dB (A). Risk of damage to hearing! <ul style="list-style-type: none"> • Wear ear protectors.
---	---

Preparation

Item	Task
Operating mode selector switch (if provided)	Change to manual mode.
Preheating pump (if provided)	Switch ON.

Starting the engine

Item	Task
Switching cabinet, control panel etc. (depending on manufacturer)	<p>If coolant temperature is</p> <ul style="list-style-type: none"> • > 40 °C (with preheating pump), or • > 10 °C (60 Hz generator, without preheating pump), or • > 5 °C (50 Hz generator, without preheating pump): <p>Press start button.</p> <ul style="list-style-type: none"> • Automatic starting procedure is performed; • Tachometer indicates increasing crankshaft speed; • After the starting procedure is completed, engine is running at rated speed.

Connecting the generator to network, running the engine to reach operating temperature

Item	Task
Switching cabinet, control panel etc. (depending on manufacturer)	Close the generator circuit breaker.
Engine	Run engine at 10 to 15 % of rated power to reach operating temperature. Apply full load only after engine has reached operating temperature (coolant temperature approx. 75 °C).

3.4 Emergency start (override mode)

 CAUTION	<p>Safety functions and engine shutdown alarms will be disregarded.</p> <p>Serious damage to plant!</p> <ul style="list-style-type: none"> • Initiate emergency start only in emergency situations.
---	---

Preparation

Item	Task
Operating mode selector switch (if provided)	Change to manual mode.

Emergency start

Item	Task
Switching cabinet, control panel etc. (depending on manufacturer)	Actuate switch/button for override input of ECU.
Switching cabinet, control panel etc. (depending on manufacturer)	<p>Press start button.</p> <ul style="list-style-type: none"> • Automatic starting procedure is performed; All safety functions are deactivated and engine shutdown alarms disregarded; • Tachometer indicates increasing crankshaft speed; • After the starting procedure is completed, engine is running at rated speed.

Connecting the generator to network

Item	Task
Switching cabinet, control panel etc. (depending on manufacturer)	If generator is not connected to network: Close the generator circuit breaker.
Engine	Run at rated power.

3.5 Operational checks

 DANGER	Unguarded rotating and moving engine components. Risk of serious injury – danger to life! <ul style="list-style-type: none"> • Take special care when working on a running engine.
--	---

 WARNING	Engine noise above 85 dB (A). Risk of damage to hearing! <ul style="list-style-type: none"> • Wear ear protectors.
---	---

Operational checks

Item	Task
Control and display panels	Check indicated operating parameters (speed, temperatures, pressures).
Engine under load Engine at nominal speed	Check all pipework for leaks, rectify any leaks with the engine stopped. Check for abnormal running noises and vibrations.
Fuel prefilter	Check if suction-side pressure indicated at the fuel prefilter pressure gauge is within the limit (→ Page 6 – 23).
Exhaust system	Check exhaust color (→ Page 5 – 1).
Intercooler	Check condensate drain(s) for water discharge and obstruction (→ Page 6 – 29).
Air filter	Check signal ring position of service indicator (→ Page 6 – 31); Replace air filter (→ Page 6 – 30), if the signal ring is completely visible in the service indicator control window.
Compressed-air system (if installed)	Check operating pressure at pressure gauge. Fill compressed-air tank to maximum pressure. Drain condensate from compressed-air tank, pressure drop must not exceed 1 bar.

3.6 Stopping the engine in manual mode

Preconditions

- Generator is not connected to network.
- Engine is running in manual mode.

 CAUTION	Stopping the engine when it is running at full load causes extreme stress to the engine. Risk of overheating, damage to components! <ul style="list-style-type: none"> • Before stopping the engine, operate it at idle speed until operating temperatures decrease and stable values are indicated.
---	---

Preparation

Item	Task
Engine	After the generator circuit breaker has been opened, allow the engine to cool down by running it idle for approx. 5 minutes.

Stopping the engine

Item	Task
Switching cabinet, control panel etc. (depending on manufacturer)	Press stop button. <ul style="list-style-type: none"> • Automatic stopping procedure is performed; • Engine is stopped.

After stopping the engine

Item	Task
Cooling pump	Operate for approx. 5 minutes after engine stop.

3.7 Emergency stop

 CAUTION	An emergency stop causes extreme stress to the engine. Risk of overheating, damage to components! <ul style="list-style-type: none"> • Initiate emergency stop only in emergency situations.
---	---

Emergency stop from LOP

Item	Task
EMERGENCY STOP button	Press. <ul style="list-style-type: none"> • Engine is stopped by switching off power supply to ECU; • Signalization (e.g. by horn, flashing lamp) is released.

After emergency stop from LOP

Item	Task
Switching cabinet, control panel etc. (depending on manufacturer)	Press button for alarm acknowledgement. <ul style="list-style-type: none"> • Audible and visual signalization stops.

3.8 After stopping the engine – engine remains ready for operation

After stopping the engine

Item	Task
Engine/generator control system	Select operating mode, e.g. MANUAL OPERATION, AUTOMATIC OPERATION.

3.9 After stopping the engine – putting the engine out of service

Preconditions

- MTU Fluids and Lubricants Specification (A001061/..) is available.

After stopping the engine

Item	Task
Cooling system	Drain engine coolant (→ Page 6 – 40); Drain charge-air coolant (→ Page 6 – 46) if: <ul style="list-style-type: none"> • freezing temperatures are expected and the engine is to remain out of service for an extended period and coolant has no antifreeze additive; • the engine room is not heated; • the coolant is not maintained at a suitable temperature; • the antifreeze concentration is insufficient for the engine-room temperature; • antifreeze concentration is 50% and engine-room temperature is below -40°C.
Engine/generator control system	Switch OFF.
Air intake and exhaust system	If the engine is to remain out of service for more than 1 week, seal the engine's air and exhaust sides. If the engine is to remain out of service for more than 1 month, carry out preservation (→ MTU Fluids and Lubricants Specification A001061/..).

4 Maintenance

4.1 Maintenance and Servicing **4 – 1**
 4.1.1 Maintenance and servicing 4 – 1

4.2 Maintenance Schedule – Application Groups 3C and 3D **4 – 2**
 4.2.1 Maintenance schedule 4 – 2

4.3 Maintenance Schedule – Application Group 3B **4 – 4**
 4.3.1 Maintenance schedule 4 – 4

4.4 Maintenance Schedule – Application Group 3A **4 – 6**
 4.4.1 Maintenance schedule 4 – 6

4.1 Maintenance and Servicing

4.1.1 Maintenance and servicing

Low operating and maintenance costs as well as operational reliability and availability depend on maintenance and servicing being carried out in compliance with our specifications and instructions. The overall system, of which the engine is an integral part, must be maintained in such a way as to ensure trouble-free engine operation. For this purpose, ensure, for instance:

- that sufficient fuel is available;
- that the combustion air is dry and clean.

Of course, your service partner will always be at your disposal to help or assist you if required.

Preventive maintenance instructions

- Special care should be taken to keep the machinery plant in a clean and serviceable condition at all times to facilitate detection of possible leaks and prevent subsequent damage.
- Protect rubber and synthetic parts from oil and fuel, never treat with organic detergents, only wipe with dry cloth.
- Always replace seals and gaskets.

Maintenance system

The maintenance concept is based on a preventive approach.

Preventive maintenance permits advance operational planning and increases availability. The maintenance schedule refers to the specified load profile. The time intervals according to which the maintenance operations are to be performed and the relevant inspection and maintenance tasks are based on operational experience and are therefore to be considered as approximate values. Particular operating conditions may require the maintenance schedule to be altered. Remanufactured parts are offered for components to be replaced.

Information on maintenance intervals

The maintenance intervals for oil and coolant are specified in the (→ MTU Fluids and Lubricants Specification, Publication No. A001061/..) Use only fluids and lubricants which are approved by MTU.

The following maintenance operations must be performed on direct responsibility of the user / customer:

Fuel prefilter:

Maintenance depends on fuel quality (purity).

The fuel prefilter must be replaced after 2 years, at the latest. (→ Page 6 – 27).

Battery:

Maintenance intervals of batteries depend on operating and ambient conditions. The information of the battery manufacturer is binding.

Out-of-service periods

If the engine is to remain out of service for more than one month, carry out engine preservation in accordance with the (→ MTU Fluids and Lubricants Specification, Publication No. A001061/..)

4.2 Maintenance Schedule – Application Groups 3C and 3D

4.2.1 Maintenance schedule

Application group

3C: Continuous operation, limited (peak-shaving)

3D: Standby operation

MTU maintenance levels

Maintenance level	Time limit	Operating hours	Scope of maintenance
W2	6 months	250	W2
W3	1 year	500	W2, W3
W4	4 years	1500	W2, W3, W4

The maintenance operations must be carried out in the following cases:

- when the time limit specified by MTU is reached;
- when the number of operating hours as per MTU maintenance level (W) is reached;
- additionally, a test run must be carried out every month. (→ Page 6 – 2).

Maintenance task schedule

W	Item	Task
W2	Air system	Check air intake for leaks.
W2	Engine oil	Take sample of used oil and analyze (→ Page 6 – 33).
W2	Engine oil	Change (→ Page 6 – 34) <ul style="list-style-type: none"> • Every 2 years • At the latest: <ul style="list-style-type: none"> With oil category 1 every 250 operating hours; With oil category 2 every 500 operating hours;
W2	Engine oil filter	Replace, accomplish when changing the oil. (→ Page 6 – 36).
W3	Valve gear	Check valve clearances (→ Page 6 – 9).
W3	Fuel filter	Replace (→ Page 6 – 22).
W3	Fuel prefilter	Replace filter element (→ Page 6 – 27).
W3	Fuel prefilter	Clean (→ Page 6 – 23).
W3	Exhaust system	Check for leaks.
W3	Engine coolant	Take sample and analyze (→ Page 6 – 43).
W3	HT coolant pump	Check relief bore for oil and coolant discharge and obstructions (→ Page 6 – 43).
W3	Charge-air coolant	Take sample and analyze (→ Page 6 – 48).
W3	LT coolant pump	Check relief bore for oil and water discharge and obstructions (→ Page 6 – 49).

W	Item	Task
W3	Engine coolant cooler	Check cooler elements for external contamination (see manufacturer's documentation).
W3	Charge-air coolant cooler	Check cooler elements for external contamination (see manufacturer's documentation).
W3	Battery	Check (see manufacturer's information).
W4	Air filter	Replace (→ Page 6 – 30).
W4	Starter	Check condition (→ Page 6 – 32).
W4	Battery-charging generator drive	Check belt condition (→ Page 6 – 50).
W4	Battery-charging generator drive	Check and adjust belt tension (→ Page 6 – 50).
W4	Battery-charging generator	Check condition (→ Page 6 – 52).
W4	Engine / generator mounts	Check tightness of securing screws (→ Page 6 – 53).
W4	Engine / generator mounts	Check condition of resilient mounts (→ Page 6 – 53).
W4	Coupling	Check condition (see manufacturer's documentation).
W4	Engine wiring	Check (→ Page 6 – 55).
W4	ECU	Check (visual inspection) (→ Page 6 – 57).
W4	ECU	Clean (→ Page 6 – 56).

4.3 Maintenance Schedule – Application Group 3B

4.3.1 Maintenance schedule

Application group

3B: Continuous operation with variable load

MTU maintenance levels

Maintenance level	Operating hours	Time limit	Scope of maintenance
W2	250	6 months	W2
W3	500	1 year	W2, W3
W4	1500	3 years	W2, W3, W4

The maintenance operations must be carried out in the following cases:

- when the number of operating hours as per MTU maintenance level (W) is reached;
- when the time limit specified by MTU is reached;
- additionally, a test run must be carried out every month. (→ Page 6 – 2).

Maintenance task schedule

W	Item	Task
W2	Air system	Check air intake for leaks.
W2	Engine oil	Take sample of used oil and analyze (→ Page 6 – 33).
W2	Engine oil	Change (→ Page 6 – 34) <ul style="list-style-type: none"> • With oil category 1 without additional oil filter: every 250 operating hours; • With oil category 1 with additional oil filter: every 500 operating hours; • With oil category 2 without additional oil filter: every 500 operating hours; • With oil category 2 with additional oil filter: every 1000 operating hours; • After 2 years at the latest.
W2	Engine oil filter	Replace, accomplish when changing the oil. (→ Page 6 – 36).
W2	Centrifugal oil filter(s)	Clean, replace sleeve (→ Page 6 – 37).
W3	Valve gear	Check valve clearances (→ Page 6 – 9).
W3	Fuel filter	Replace (→ Page 6 – 22).
W3	Fuel prefilter	Replace filter element (→ Page 6 – 27).
W3	Fuel prefilter	Clean (→ Page 6 – 23).
W3	Exhaust system	Check for leaks.
W3	Engine coolant	Take sample and analyze (→ Page 6 – 43).
W3	HT coolant pump	Check relief bore for oil and coolant discharge and obstructions (→ Page 6 – 43).
W3	Charge-air coolant	Take sample and analyze (→ Page 6 – 48).

W	Item	Task
W3	LT coolant pump	Check relief bore for oil and water discharge and obstructions (→ Page 6 – 49).
W3	Engine coolant cooler	Check cooler elements for external contamination (see manufacturer's documentation).
W3	Charge-air coolant cooler	Check cooler elements for external contamination (see manufacturer's documentation).
W3	Coupling	Check condition (see manufacturer's documentation).
W3	Battery	Check (see manufacturer's information).
W4	Air filter	Replace (→ Page 6 – 30).
W4	Starter	Check condition (→ Page 6 – 32).
W4	Battery-charging generator drive	Check belt condition (→ Page 6 – 50).
W4	Battery-charging generator drive	Check and adjust belt tension (→ Page 6 – 50).
W4	Battery-charging generator	Check condition (→ Page 6 – 52).
W4	Engine / generator mounts	Check tightness of securing screws (→ Page 6 – 53).
W4	Engine / generator mounts	Check condition of resilient mounts (→ Page 6 – 53).
W4	Engine wiring	Check (→ Page 6 – 55).
W4	ECU	Check (visual inspection) (→ Page 6 – 57).
W4	ECU	Clean (→ Page 6 – 56).

4.4 Maintenance Schedule – Application Group 3A

4.4.1 Maintenance schedule

Application group

3A: Continuous operation at 100% load, unrestricted

MTU maintenance levels

Maintenance level	Operating hours	Time limit	Scope of maintenance
W2	500	6 months	W2
W3	1000	1 year	W2, W3
W4	5000	2 years	W2, W3, W4

The maintenance operations must be carried out in the following cases:

- when the number of operating hours as per MTU maintenance level (W) is reached;
- when the time limit specified by MTU is reached;
- additionally, a test run must be carried out every month. (→ Page 6 – 2).

Maintenance task schedule

W	Item	Task
W2	Fuel filter	Replace (→ Page 6 – 22).
W2	Fuel prefilter	Replace filter element (→ Page 6 – 27).
W2	Fuel prefilter	Clean (→ Page 6 – 23).
W2	Air system	Check air intake for leaks.
W2	Engine oil	Take sample of used oil and analyze (→ Page 6 – 33).
W2	Engine oil	Change (→ Page 6 – 34) <ul style="list-style-type: none"> • With oil category 1 without additional oil filter: every 250 operating hours; • With oil category 1 with additional oil filter: every 500 operating hours; • With oil category 2 without additional oil filter: every 500 operating hours; • With oil category 2 with additional oil filter: every 1000 operating hours;
W2	Engine oil filter	Replace, accomplish when changing the oil. (→ Page 6 – 36).
W2	Centrifugal oil filter(s)	Clean, replace sleeve (→ Page 6 – 37).
W3	Valve gear	Check valve clearances (→ Page 6 – 9).
W3	Exhaust system	Check for leaks.
W3	Engine coolant	Take sample and analyze (→ Page 6 – 43).
W3	HT coolant pump	Check relief bore for oil and coolant discharge and obstructions (→ Page 6 – 43).
W3	Charge-air coolant	Take sample and analyze (→ Page 6 – 48).

W	Item	Task
W3	LT coolant pump	Check relief bore for oil and water discharge and obstructions (→ Page 6 – 49).
W3	Engine coolant cooler	Check cooler elements for external contamination (see manufacturer's documentation).
W3	Charge-air coolant cooler	Check cooler elements for external contamination (see manufacturer's documentation).
W3	Coupling	Check condition (see manufacturer's documentation).
W3	Battery	Check (see manufacturer's information).
W4	Combustion chambers	Perform endoscopic examination (→ Page 6 – 3).
W4	Injectors	Replace (→ Page 6 – 15).
W4	Air filter	Replace (→ Page 6 – 30).
W4	Starter	Check condition (→ Page 6 – 32).
W4	Battery-charging generator drive	Check belt condition (→ Page 6 – 50).
W4	Battery-charging generator drive	Check and adjust belt tension (→ Page 6 – 50).
W4	Battery-charging generator	Check condition (→ Page 6 – 52).
W4	Engine / generator mounts	Check tightness of securing screws (→ Page 6 – 53).
W4	Engine / generator mounts	Check condition of resilient mounts (→ Page 6 – 53).
W4	Engine wiring	Check (→ Page 6 – 55).
W4	ECU	Check (visual inspection) (→ Page 6 – 57).
W4	ECU	Clean (→ Page 6 – 56).

5 Troubleshooting

5.1 Troubleshooting	5 – 1
5.2 ECU alarms	5 – 4

5.1 Troubleshooting

Engine does not turn when starter is actuated

Component	Probable Cause	Task
Battery	Low or defective	Charge or replace (see manufacturer's documentation).
	Cable connections defective	Check if cable connections are properly secured (see manufacturer's documentation).
Starter	Engine wiring or starter defective	Check if cable connections are properly secured, contact Service.
Engine wiring	Defective	Check (→ Page 6 – 55).
Engine/generator control system	Secure seating of assemblies or connectors not provided	Perform visual inspection (see manufacturer's documentation).
ECU	Plug-in connections are loose	Check plug-in connections (→ Page 6 – 57).
Engine	Running gear blocked (engine cannot be barred manually)	Contact Service.

Engine turns but does not fire

Component	Probable Cause	Task
Starter	Poor rotation by starter: Battery low or defective	Charge or replace battery (see manufacturer's documentation).
Engine wiring	Defective	Check (→ Page 6 – 55).
Fuel system	Not vented	Vent (→ Page 6 – 21).
ECU	Defective	Contact Service.

Engine fires unevenly

Component	Probable Cause	Task
Fuel injection equipment	Injector defective	Replace (→ Page 6 – 15).
Engine wiring	Defective	Check (→ Page 6 – 55).
Fuel system	Not vented	Vent (→ Page 6 – 21).
ECU	Defective	Contact Service.

Engine does not reach nominal speed

Component	Probable Cause	Task
Fuel supply	Fuel prefilter clogged	Replace filter element (→ Page 6 – 27).
	Fuel filter clogged	Replace (→ Page 6 – 22).
Air supply	Air filter clogged	Check signal ring position of service indicator (→ Page 6 – 31).
Fuel injection equipment	Injector defective	Replace (→ Page 6 – 15).
Engine wiring	Defective	Check (→ Page 6 – 55).
Engine	Overloaded	Contact Service.

Engine speed not steady

Component	Probable Cause	Task
Fuel injection equipment	Injector defective	Replace (→ Page 6 – 15).
Speed sensor	Defective	Contact Service.
Fuel system	Not vented	Vent (→ Page 6 – 21).
ECU	Defective	Contact Service.

Charge-air temperature too high

Component	Probable Cause	Task
Engine coolant	Incorrect coolant concentration	Check (MTU test kit).
Intercooler	Contaminated	Contact Service.
Engine room	Air-intake temperature too high	Check fans and air supply / ventilation ducts.

Charge air pressure too low

Component	Probable Cause	Task
Air supply	Air filter clogged	Check signal ring position of service indicator (→ Page 6 – 31).
Intercooler	Contaminated	Contact Service.
Exhaust turbocharger	Defective	Contact Service.

Coolant leaks on intercooler

Component	Probable Cause	Task
Intercooler	Leaking, major coolant discharge	Contact Service.

Exhaust gas black

Component	Probable Cause	Task
Air supply	Air filter clogged	Check signal ring position of service indicator (→ Page 6 – 31).
Fuel injection equipment	Injector defective	Replace (→ Page 6 – 15).
Engine	Overloaded	Contact Service.

Exhaust gas blue

Component	Probable Cause	Task
Engine oil	Too much oil in engine	Drain engine oil (→ Page 6 – 34).
	Oil separator of crankcase breather contaminated	Replace filter element (→ Page 6 – 7).
Exhaust turbocharger, cylinder head, piston rings, cylinder liner	Defective	Contact Service.

Exhaust gas white

Component	Probable Cause	Task
Engine	Not at operating temperature	Run engine to reach operating temperature.
Fuel system	Water in fuel	Check fuel system on fuel prefilter. Drain fuel prefilter (→ Page 6 – 24).
Intercooler	Leaking	Contact Service.

5.2 ECU alarms

The ECU generates alarms which are indicated in different ways depending on the equipment configuration:

- as four-digit code on a PIM
- as alarm text on a display
- as four-digit code on a dialog PC

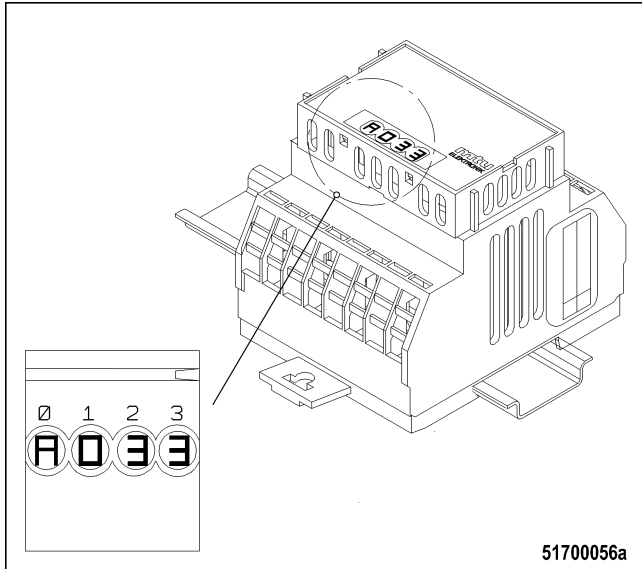

The four-digit code consists of one letter and three figures:

- The letter encodes when the fault occurred the last time:
 - A = currently present
 - B = within the last operating hour
 - C = one to four operating hours ago
 - D = four to twelve operating hours ago
 Alarms that occurred more than twelve hours ago are deleted automatically.
- The three figures encode the fault itself as listed in the table below.

Alarms can also be caused by defective sensors / actuators. If troubleshooting in accordance with the following table is not successful, contact Service to have the sensors / actuators checked and, if required, replaced.

Fault code	Alarm text	Meaning	Task
005	L1 T-CHARGE AIR	Charge-air temperature too high (1st limit)	Reduce power.
006	L2 T-CHARGE AIR	Charge-air temperature too high (2nd limit)	Reduce power.
009	L1 T-INTER-COOLER	Charge-air coolant temperature too high (1st limit)	Reduce power.
015	L1 P-LUBE OIL	Lube-oil pressure too low (1st limit)	Check engine-oil level and top up, if required; (→ Page 6 – 35);
016	L2 P-LUBE OIL	Lube-oil pressure too low (2nd limit) automatic engine shutdown	1. Check engine-oil level and top up, if required; (→ Page 6 – 35); 2. Try to re-start the engine (→ Page 3 – 2). 3. Contact Service.

Fault code	Alarm text	Meaning	Task
023	L1 COOLANT LEVEL	Engine coolant level too low	Check coolant level and top up, if required (→ Page 6 – 42) .
024	L2 COOLANT LEVEL	Engine coolant level too low	Check coolant level and top up, if required (→ Page 6 – 42) .
030	ENGINE OVERSPEED	Engine overspeed; automatic engine shutdown	<ol style="list-style-type: none"> 1. Acknowledge alarm. 2. Try to re-start the engine (→ Page 3 – 2). 3. Contact Service.
044	L1 LEVEL INTERCOOLER	Charge-air coolant level too low (1st limit)	Check coolant level and top up, if required (→ Page 6 – 48) .
045	L2 LEVEL INTERCOOLER	Charge-air coolant level too low (2nd limit)	<ol style="list-style-type: none"> 1. Check coolant level and top up, if required (→ Page 6 – 48) . 2. If fault occurs repeatedly: Contact Service.
051	L1 T-LUBE OIL	Lube-oil temperature too high (1st limit)	Reduce power.
052	L2 T-LUBE OIL	Lube-oil temperature too high (2nd limit)	<ol style="list-style-type: none"> 1. Reduce power. 2. If fault occurs repeatedly: Contact Service.
065	L1 P-FUEL	Fuel supply pressure too low (1st limit)	<ol style="list-style-type: none"> 1. Check fuel lines for leaks; repair defective lines. 2. Clean fuel prefilter (→ Page 6 – 23). 3. Flush fuel prefilter (→ Page 6 – 25). 4. Replace filter element of fuel prefilter (→ Page 6 – 27). 5. Replace filter element of fuel prefilter (→ Page 6 – 22). 6. If fault is not rectified: Contact Service.
066	L2 P-FUEL	Fuel supply pressure too low (2nd limit)	<ol style="list-style-type: none"> 1. Check fuel lines for leaks; repair defective lines. 2. Clean fuel prefilter (→ Page 6 – 23). 3. Flush fuel prefilter (→ Page 6 – 25). 4. Replace filter element of fuel prefilter (→ Page 6 – 27). 5. Replace filter element of fuel prefilter (→ Page 6 – 22). 6. If fault is not rectified: Contact Service.
067	L1 T-COOLANT	Coolant temperature too high (1st limit); warning	Reduce power.
068	L2 T-COOLANT	Coolant temperature too high (2nd limit); automatic engine shutdown	<ol style="list-style-type: none"> 1. Allow the engine to cool down. 2. Check coolant cooler (elements etc.) and clean contaminated parts (see manufacturer's documentation). 3. Re-start the engine (→ Page 3 – 2). 4. If fault occurs repeatedly: Contact Service.

Fault code	Alarm text	Meaning	Task
069	L1 T-EXTERN 1	Violation of first limit for external temperature channel 1	(Depending on the corresponding measuring point, which is read via CAN bus)
070	L2 T-EXTERN 1	Violation of second limit for external temperature channel 1	(Depending on the corresponding measuring point, which is read via CAN bus)
071	L1 T-EXTERN 2	Violation of first limit for external temperature channel 2	(Depending on the corresponding measuring point, which is read via CAN bus)
072	L2 T-EXTERN 2	Violation of second limit for external temperature channel 2	(Depending on the corresponding measuring point, which is read via CAN bus)
073	L1 P-EXTERN 1	Violation of first limit for external pressure channel 1	(Depending on the corresponding measuring point, which is read via CAN bus)
074	L2 P-EXTERN 1	Violation of second limit for external pressure channel 1	(Depending on the corresponding measuring point, which is read via CAN bus)
075	L1 P-EXTERN 2	Violation of first limit for external pressure channel 2	(Depending on the corresponding measuring point, which is read via CAN bus)
076	L2 P-EXTERN 2	Violation of second limit for external pressure channel 2	(Depending on the corresponding measuring point, which is read via CAN bus)
077	LIM EXT.COOLANT LEV.	Alarm from external coolant level monitoring	(Depending on the corresponding measuring point, which is read via CAN bus)
078	LIM INTERCOOLER LEV.	Alarm from external charge-air coolant level monitoring	(Depending on the corresponding measuring point, which is read via CAN bus)
079	L Bin-EXTERN 3	Alarm from external binary channel 3	(Depending on the corresponding measuring point, which is read via CAN bus)
080	L Bin-EXTERN 4	Alarm from external binary channel 4	(Depending on the corresponding measuring point, which is read via CAN bus)
081	RAIL LEAKAGE	HP fuel system leaking, system contains air	Contact Service.
082	RAIL PRESSURE HIGH	Pressure in HP fuel system exceeds specified value; Solenoid valve of HP fuel control block jamming or wiring to solenoid valve defective	Contact Service.

Fault code	Alarm text	Meaning	Task
083	RAIL PRESSURE LOW	Pressure in HP fuel system lower than the specified value; HP fuel control block defective or system leaking NOTE: With very large generators having a run-out time of more than > 20 sec this alarm is not a relevant fault.	Contact Service.
089	ENGINE SPEED LOW	Engine speed lower than 200 rpm; automatic engine shutdown	Re-start the engine (→ Page 3 – 2).
090	IDLE SPEED LOW	Idle speed not reached within a specified period; Termination of starting procedure.	Note further alarms.
091	RUN UP SPEED LOW	Run-up speed not reached within a specified period; Termination of starting procedure.	Note further alarms.
092	START SPEED LOW	Starter speed not reached within a specified period; Termination of starting procedure.	Note further alarms.
093	PREHEAT TEMP. LIMIT2	Coolant preheating temperature too low during starting (2nd limit) Termination of starting procedure (depending on project design)	Check preheating pump / preheating system (see manufacturer's documentation).
094	PREHEAT TEMP. LIMIT1	Coolant preheating temperature too low during starting (1st limit)	Check preheating pump / preheating system (see manufacturer's documentation).
100	EDM NOT VALID	Check sum error of measuring-point data in EDM	If fault occurs repeatedly: Contact Service.
101	IDM NOT VALID	Check sum error of measuring-point data in IDM	If fault occurs repeatedly: Contact Service.
102	INVALID FUEL CONS. 1	Check sum error of accumulated fuel consumption data in EDM (redundant data record 1)	If fault occurs repeatedly: Contact Service.
103	INVALID FUEL CONS. 2	Check sum error of accumulated fuel consumption data in EDM (redundant data record 2)	If fault occurs repeatedly: Contact Service.

Fault code	Alarm text	Meaning	Task
104	OP HOURS1 NOT VALID	Check sum error of hour meter data in EDM	If fault occurs repeatedly: Contact Service.
105	OP HOURS2 NOT VALID	Check sum error of hour meter data in IDM	If fault occurs repeatedly: Contact Service.
106	ERR REC1 NOT VALID	Check sum error of fault memory in EDM (redundant data record 1)	If fault occurs repeatedly: Contact Service.
107	ERR REC2 NOT VALID	Check sum error of fault memory in EDM (redundant data record 2)	If fault occurs repeatedly: Contact Service.
118	L1 SUPPLY VOLT. LOW	Supply voltage too low (1st limit)	Check ECU supply voltage.
119	L2 SUPPLY VOLT. LOW	Supply voltage too low (2nd limit)	Check ECU supply voltage.
120	L1 SUPPLY VOLT. HIGH	Supply voltage too high(1st limit)	Check ECU supply voltage.
121	L2 SUPPLY VOLT. HIGH	Supply voltage too high (2nd limit); automatic engine shutdown (depending on project design)	Check ECU supply voltage. If engine was stopped: Start engine (→ Page 3 – 2).
122	L1 T-ELECTRONIC	Temperature in ECU housing too high (1st limit)	1. Improve engine room ventilation. 2. Reduce engine power.
134	15V POS ECU DEFECT	Electronic equipment defective; automatic engine shutdown	Contact Service.
136	15V NEG ECU DEFECT	Electronic equipment defective; automatic engine shutdown	Contact Service.
137	L1 5V BUFFER TEST	Power supply for pressure sensors defective.	1. Disconnect connectors X2 and X3 from ECU. If alarm does not disappear: Contact Service. 2. Check wiring (pressure sensors). 3. Contact Service.
138	SENSORPOW- ERDEFECT	Power supply for pressure sensors defective.	1. Disconnect connectors X2 and X3 from ECU. If alarm does not disappear: Contact Service. 2. Check wiring (pressure sensors). 3. Contact Service.
139	L1 TE BUFFER TEST	Internal electronic fault (temperature sensors)	Contact Service.
140	TE BUF. ECU DEFECT	Internal electronic fault (temperature sensors)	Contact Service.
142	BANK1 ECU DEFECT	Internal electronic fault; Engine does not start	Contact Service.

Fault code	Alarm text	Meaning	Task
144	BANK2 ECU DEFECT	Internal electronic fault; Engine does not start	Contact Service.
145	15V_GOOD ECU DEFECT	Electronic equipment defective; automatic engine shutdown	Contact Service.
146	L1 AD-TEST1 SUPPLY	A/D-converter supply voltage too low	Contact Service.
147	AD-TEST1 ECU DEFECT	Electronic equipment defective; automatic engine shutdown	Contact Service.
148	L1 AD-TEST2 SUPPLY	A/D-converter supply voltage too low	Contact Service.
149	AD-TEST2 ECU DEFECT	Electronic equipment defective; automatic engine shutdown	Contact Service.
150	L1 AD-TEST3 SUPPLY	A/D-converter supply voltage too low	Contact Service.
151	AD-TEST3 ECU DEFECT	Electronic equipment defective; automatic engine shutdown	Contact Service.
170	MI MODULE FAIL	Module in maintenance predictor either defective or missing	Contact Service.
171	MI NOT ACTIVE	Maintenance predictor no more activated	Contact Service.
173	MODULE WRITE LIMIT	EEPROM write limit reached	Contact Service.
180	CAN1 NODE LOST	At least one device not detected on Default CAN bus	1. Check wiring (CAN bus). 2. Contact Service.
181	CAN2 NODE LOST	At least one device not detected on Redundant CAN bus	1. Check wiring (CAN bus). 2. Contact Service.
182	CAN WRONG PARAMETERS	Consistency error in CAN parameters	Contact Service.
183	CAN NO PU-DATA	Error during loading of CAN project design data into ECU.	Contact Service.
184	CAN PU-DATA EE-FAIL	Error during project design data download in EEPROMs	Contact Service.
185	CAN LESS MAILBOXES	Error during CAN initialization.	Contact Service.
186	CAN1 BUS OFF	Severe fault on Default CAN bus; automatic change-over to Redundant CAN bus	Contact Service.

Fault code	Alarm text	Meaning	Task
187	CAN1 ERROR PASSIVE	Light fault on Default CAN bus (e.g.shortage overload)	(none)
188	CAN2 BUS OFF	Severe fault on Redundant CAN bus; automatic change-over to Default CAN bus	Contact Service.
189	CAN2 ERROR PASSIVE	Light fault on Redundant CAN bus (e.g.short-time overload)	(none)
201	SD T-COOLANT	Sensor defect (coolant temperature)	1. Check wiring. 2. Contact Service.
202	SD T-FUEL	Sensor defect (Fuel temperature)	1. Check wiring. 2. Contact Service.
203	SD T-CHARGE AIR	Sensor defect (charge-air temperature)	1. Check wiring. 2. Contact Service.
205	SD T-COOLANT INTERC.	Sensor defect (charge-air coolant temperature)	1. Check wiring. 2. Contact Service.
208	SD P-CHARGE AIR	Sensor defect (charge-air pressure)	1. Check wiring. 2. Contact Service.
211	SD P-LUBE OIL	Sensor defect (lube oil pressure)	1. Check wiring. 2. Contact Service.
215	SD P-RAIL FUEL	Sensor defect (common rail pressure); HP controller in emergency mode	1. Check wiring. 2. Contact Service.
216	SD T-LUBE OIL	Sensor defect (lube oil temperature)	1. Check wiring. 2. Contact Service.
220	SD COOLANT LEVEL	Sensor defect (coolant level)	1. Check wiring. 2. Contact Service.
223	SD LEVEL INTERCOOLER	Sensor defect (charge-air coolant level)	1. Check wiring. 2. Contact Service.
229	SD ENG.SPEED SENSORS	Sensor defect (crankshaft speed) and sensor defect (camshaft speed)	1. Check wiring. 2. Contact Service.
230	SD CRANKSHAFT SPEED	Sensor defect (crankshaft speed)	1. Check wiring. 2. Contact Service.
231	SD CAMSHAFT SPEED	Sensor defect (camshaft speed)	1. Check wiring. 2. Contact Service.
240	SD P-FUEL	Sensor defect (fuel pressure)	1. Check wiring. 2. Contact Service.
245	SD POWER SUPPLY	Sensor defect (ECU operating voltage)	Contact Service.
246	SD T-ELECTRONIC	Sensor defect (temperature in ECU)	Contact Service.

Fault code	Alarm text	Meaning	Task
250	SD CAN SPEED DEMAND	Sensor defect (CAN nominal speed demand)	1. Check speed transmitter. 2. Check wiring (CAN bus). 3. Contact Service.
266	SD SPEED DEMAND AN.	Sensor defect (analog nominal speed demand)	1. Check speed transmitter. 2. Check wiring. 3. Contact Service.
267	SD SP.DEM.TEST BENCH	Sensor defect (analog speed demand); NOTE: Only used in test-stand operation.	1. Check speed transmitter. 2. Check wiring. 3. Contact Service.
270	SD SPEED DEMAND F11	Sensor defect (frequency input for speed demand);	1. Check speed transmitter. 2. Check wiring. 3. Contact Service.
271	SD T-EXTERN 1	External device defective (CAN T-EXTERN 1)	Contact Service.
272	SD T-EXTERN 2	External device defective (CAN T-EXTERN 2)	Contact Service.
273	SD P-EXTERN 1	External device defective (CAN P-EXTERN 1)	Contact Service.
274	SD P-EXTERN 2	External device defective (CAN P-EXTERN 2)	Contact Service.
275	SD EXT.COOLANT LEVEL	External coolant-level monitoring defective (CAN)	Contact Service.
276	SD INTERCOOLER LEVEL	External charge-air coolant-level monitoring defective (CAN)	Contact Service.
277	SD BIN-EXTERN 3	External device defective (CAN BIN-EXTERN 3)	Contact Service.
278	SD BIN-EXTERN 4	External device defective (CAN BIN-EXTERN 4)	Contact Service.
301	TIMING CYLINDER A1	Injection timing fault cylinder A1	If fault occurs repeatedly: Contact Service.
302	TIMING CYLINDER A2	Injection timing fault cylinder A2	If fault occurs repeatedly: Contact Service.
303	TIMING CYLINDER A3	Injection timing fault cylinder A3	If fault occurs repeatedly: Contact Service.
304	TIMING CYLINDER A4	Injection timing fault cylinder A4	If fault occurs repeatedly: Contact Service.
305	TIMING CYLINDER A5	Injection timing fault cylinder A5	If fault occurs repeatedly: Contact Service.
306	TIMING CYLINDER A6	Injection timing fault cylinder A6	If fault occurs repeatedly: Contact Service.

Fault code	Alarm text	Meaning	Task
307	TIMING CYLINDER A7	Injection timing fault cylinder A7	If fault occurs repeatedly: Contact Service.
308	TIMING CYLINDER A8	Injection timing fault cylinder A8	If fault occurs repeatedly: Contact Service.
309	TIMING CYLINDER A9	Injection timing fault cylinder A9	If fault occurs repeatedly: Contact Service.
310	TIMING CYLINDER A10	Injection timing fault cylinder A10	If fault occurs repeatedly: Contact Service.
311	TIMING CYLINDER B1	Injection timing fault cylinder B1	If fault occurs repeatedly: Contact Service.
312	TIMING CYLINDER B2	Injection timing fault cylinder B2	If fault occurs repeatedly: Contact Service.
313	TIMING CYLINDER B3	Injection timing fault cylinder B3	If fault occurs repeatedly: Contact Service.
314	TIMING CYLINDER B4	Injection timing fault cylinder B4	If fault occurs repeatedly: Contact Service.
315	TIMING CYLINDER B5	Injection timing fault cylinder B5	If fault occurs repeatedly: Contact Service.
316	TIMING CYLINDER B6	Injection timing fault cylinder B6	If fault occurs repeatedly: Contact Service.
317	TIMING CYLINDER B7	Injection timing fault cylinder B7	If fault occurs repeatedly: Contact Service.
318	TIMING CYLINDER B8	Injection timing fault cylinder B8	If fault occurs repeatedly: Contact Service.
319	TIMING CYLINDER B9	Injection timing fault cylinder B9	If fault occurs repeatedly: Contact Service.
320	TIMING CYLINDER B10	Injection timing fault cylinder B10	If fault occurs repeatedly: Contact Service.
321	WIRING CYLINDER A1	Faulty wiring to solenoid valve cylinder A1; Misfiring	1. Check wiring. 2. Contact Service.
322	WIRING CYLINDER A2	Faulty wiring to solenoid valve cylinder A2; Misfiring	1. Check wiring. 2. Contact Service.
323	WIRING CYLINDER A3	Faulty wiring to solenoid valve cylinder A3; Misfiring	1. Check wiring. 2. Contact Service.
324	WIRING CYLINDER A4	Faulty wiring to solenoid valve cylinder A4; Misfiring	1. Check wiring. 2. Contact Service.
325	WIRING CYLINDER A5	Faulty wiring to solenoid valve cylinder A5; Misfiring	1. Check wiring. 2. Contact Service.

Fault code	Alarm text	Meaning	Task
326	WIRING CYLINDER A6	Faulty wiring to solenoid valve cylinder A6; Misfiring	1. Check wiring. 2. Contact Service.
327	WIRING CYLINDER A7	Faulty wiring to solenoid valve cylinder A7; Misfiring	1. Check wiring. 2. Contact Service.
328	WIRING CYLINDER A8	Faulty wiring to solenoid valve cylinder A8; Misfiring	1. Check wiring. 2. Contact Service.
329	WIRING CYLINDER A9	Faulty wiring to solenoid valve cylinder A9; Misfiring	1. Check wiring. 2. Contact Service.
330	WIRING CYLINDER A10	Faulty wiring to solenoid valve cylinder A10; Misfiring	1. Check wiring. 2. Contact Service.
331	WIRING CYLINDER B1	Faulty wiring to solenoid valve cylinder B1; Misfiring	1. Check wiring. 2. Contact Service.
332	WIRING CYLINDER B2	Faulty wiring to solenoid valve cylinder B2; Misfiring	1. Check wiring. 2. Contact Service.
333	WIRING CYLINDER B3	Faulty wiring to solenoid valve cylinder B3; Misfiring	1. Check wiring. 2. Contact Service.
334	WIRING CYLINDER B4	Faulty wiring to solenoid valve cylinder B4; Misfiring	1. Check wiring. 2. Contact Service.
335	WIRING CYLINDER B5	Faulty wiring to solenoid valve cylinder B5; Misfiring	1. Check wiring. 2. Contact Service.
336	WIRING CYLINDER B6	Faulty wiring to solenoid valve cylinder B6; Misfiring	1. Check wiring. 2. Contact Service.
337	WIRING CYLINDER B7	Faulty wiring to solenoid valve cylinder B7; Misfiring	1. Check wiring. 2. Contact Service.
338	WIRING CYLINDER B8	Faulty wiring to solenoid valve cylinder B8; Misfiring	1. Check wiring. 2. Contact Service.
339	WIRING CYLINDER B9	Faulty wiring to solenoid valve cylinder B9; Misfiring	1. Check wiring. 2. Contact Service.

Fault code	Alarm text	Meaning	Task
340	WIRING CYLINDER B10	Faulty wiring to solenoid valve cylinder B10; Misfiring	1. Check wiring. 2. Contact Service.
341	OPEN_LOAD CYL. A1	Disconnection in wiring to solenoid valve cylinder A1; Misfiring	1. Check wiring. 2. Contact Service.
342	OPEN_LOAD CYL. A2	Disconnection in wiring to solenoid valve cylinder A2; Misfiring	1. Check wiring. 2. Contact Service.
343	OPEN_LOAD CYL. A3	Disconnection in wiring to solenoid valve cylinder A3; Misfiring	1. Check wiring. 2. Contact Service.
344	OPEN_LOAD CYL. A4	Disconnection in wiring to solenoid valve cylinder A4; Misfiring	1. Check wiring. 2. Contact Service.
345	OPEN_LOAD CYL. A5	Disconnection in wiring to solenoid valve cylinder A5; Misfiring	1. Check wiring. 2. Contact Service.
346	OPEN_LOAD CYL. A6	Disconnection in wiring to solenoid valve cylinder A6; Misfiring	1. Check wiring. 2. Contact Service.
347	OPEN_LOAD CYL. A7	Disconnection in wiring to solenoid valve cylinder A7; Misfiring	1. Check wiring. 2. Contact Service.
348	OPEN_LOAD CYL. A8	Disconnection in wiring to solenoid valve cylinder A8; Misfiring	1. Check wiring. 2. Contact Service.
349	OPEN_LOAD CYL. A9	Disconnection in wiring to solenoid valve cylinder A9; Misfiring	1. Check wiring. 2. Contact Service.
350	OPEN_LOAD CYL. A10	Disconnection in wiring to solenoid valve cylinder A10; Misfiring	1. Check wiring. 2. Contact Service.
351	OPEN_LOAD CYL. B1	Disconnection in wiring to solenoid valve cylinder B1; Misfiring	1. Check wiring. 2. Contact Service.
352	OPEN_LOAD CYL. B2	Disconnection in wiring to solenoid valve cylinder B2; Misfiring	1. Check wiring. 2. Contact Service.
353	OPEN_LOAD CYL. B3	Disconnection in wiring to solenoid valve cylinder B3; Misfiring	1. Check wiring. 2. Contact Service.

Fault code	Alarm text	Meaning	Task
354	OPEN_LOAD CYL. B4	Disconnection in wiring to solenoid valve cylinder B4; Misfiring	1. Check wiring. 2. Contact Service.
355	OPEN_LOAD CYL. B5	Disconnection in wiring to solenoid valve cylinder B5; Misfiring	1. Check wiring. 2. Contact Service.
356	OPEN_LOAD CYL. B6	Disconnection in wiring to solenoid valve cylinder B6; Misfiring	1. Check wiring. 2. Contact Service.
357	OPEN_LOAD CYL. B7	Disconnection in wiring to solenoid valve cylinder B7; Misfiring	1. Check wiring. 2. Contact Service.
358	OPEN_LOAD CYL. B8	Disconnection in wiring to solenoid valve cylinder B8; Misfiring	1. Check wiring. 2. Contact Service.
359	OPEN_LOAD CYL. B9	Disconnection in wiring to solenoid valve cylinder B9; Misfiring	1. Check wiring. 2. Contact Service.
360	OPEN_LOAD CYL. B10	Disconnection in wiring to solenoid valve cylinder B10; Misfiring	1. Check wiring. 2. Contact Service.
361	POWER STAGE FAIL 1	Defect in ECU (solenoid valve power stage)	Contact Service.
362	POWER STAGE FAIL 2	Defect in ECU (solenoid valve power stage)	Contact Service.
363	STOP POWER STAGE 1	Solenoid valve or wiring or ECU defective automatic engine shutdown	1. Check wiring. 2. Try to re-start the engine (→ Page 3 – 2). 3. Contact Service.
364	STOP POWER STAGE 2	Solenoid valve or wiring or ECU defective automatic engine shutdown	1. Check wiring. 2. Try to re-start the engine (→ Page 3 – 2). 3. Contact Service.
365	STOP MV-WIRING	Solenoid-valve wiring faulty; automatic engine shutdown	1. Check wiring. 2. Try to re-start the engine (→ Page 3 – 2). 3. Contact Service.
381	TRAN.OUT1 PLANT DEF	Binary transistor output plant 1 defective	Contact Service.
382	TRAN.OUT2 PLANT DEF	Binary transistor output plant 2 defective	Contact Service.
383	TRAN.OUT3 PLANT DEF	Binary transistor output plant 3 defective	Contact Service.
384	TRAN.OUT4 PLANT DEF	Binary transistor output plant 4 defective	Contact Service.

Fault code	Alarm text	Meaning	Task
385	TRAN.OUT5 PLANT DEF	Binary transistor output plant 5 defective	Contact Service.
386	TRAN.OUT6 PLANT DEF	Binary transistor output plant 6 defective	Contact Service.

6 Task Description

6.1 Engine	6 – 1
6.1.1 Engine – barring manually	6 – 1
6.1.2 Engine – barring with starting system	6 – 1
6.1.3 Engine test run	6 – 2
6.2 Cylinder Liner	6 – 3
6.2.1 Cylinder-liner endoscopic examination	6 – 3
6.2.2 Instructions and comments on endoscopic and visual examination of cylinder liner	6 – 5
6.3 Crankcase Breather	6 – 7
6.3.1 Crankcase breather – oil separator replacement and diaphragm check	6 – 7
6.4 Valve Gear	6 – 9
6.4.1 Valve gear lubrication	6 – 9
6.4.2 Valve clearance check and adjustment	6 – 9
6.4.3 Cylinder-head cover removal and installation	6 – 13
6.5 Fuel Injector	6 – 15
6.5.1 Injector replacement	6 – 15
6.5.2 Injector removal and installation	6 – 15
6.6 Fuel system	6 – 21
6.6.1 Fuel system venting	6 – 21
6.7 Fuel Filter	6 – 22
6.7.1 Fuel filter replacement	6 – 22
6.7.2 Fuel prefilter cleaning	6 – 23
6.7.3 Fuel prefilter – differential pressure check and adjustment of gauge	6 – 23
6.7.4 Fuel prefilter – draining	6 – 24
6.7.5 Fuel prefilter – flushing	6 – 25
6.7.6 Fuel prefilter – filter element replacement	6 – 27
6.8 Charge-Air Cooling, General, Left Side	6 – 29
6.8.1 Intercooler – checking condensate drains for coolant discharge and obstruction	6 – 29
6.9 Air Filter	6 – 30
6.9.1 Air filter replacement	6 – 30
6.9.2 Air filter removal and installation	6 – 30
6.10 Air Intake	6 – 31
6.10.1 Service indicator – signal ring position check	6 – 31
6.11 Starting System	6 – 32
6.11.1 Starter condition check	6 – 32
6.11.2 Air starter – manual operation	6 – 32
6.12 Lube Oil System	6 – 33
6.12.1 Engine-oil sample extraction and analysis	6 – 33
6.12.2 Engine oil change	6 – 34
6.12.3 Engine oil level check	6 – 35

6.13 Oil Filtration / Cooling	6 – 36
6.13.1 Engine oil filter replacement	6 – 36
6.13.2 Centrifugal oil filter – cleaning and filter-sleeve replacement	6 – 37
6.14 Cooling System, General, HT Circuit	6 – 39
6.14.1 Engine coolant system filling	6 – 39
6.14.2 Engine coolant draining	6 – 40
6.14.3 Engine coolant change	6 – 41
6.14.4 Engine coolant-level check	6 – 42
6.14.5 Engine coolant – sample extraction and analysis	6 – 43
6.14.6 HT cooling pump – relief bore check	6 – 43
6.15 Cooling System, LT Circuit	6 – 45
6.15.1 Charge-air coolant system filling	6 – 45
6.15.2 Charge-air coolant draining	6 – 46
6.15.3 Charge-air coolant change	6 – 47
6.15.4 Charge-air coolant level check	6 – 48
6.15.5 Charge-air coolant sample extraction and analysis	6 – 48
6.15.6 LT cooling pump – relief bore check	6 – 49
6.16 Battery-Charging Generator	6 – 50
6.16.1 Battery-charging generator drive – drive belt condition check	6 – 50
6.16.2 Battery-charging generator drive – drive-belt tension check and adjustment	6 – 50
6.16.3 Battery-charging generator drive – drive belt replacement	6 – 51
6.16.4 Battery-charging generator – condition check	6 – 52
6.17 Engine Mounts	6 – 53
6.17.1 Engine/generator mounting security check	6 – 53
6.17.2 Engine/generator mounting – resilient elements check	6 – 53
6.18 General Wiring, Engine / Gearbox / Plant	6 – 55
6.18.1 Engine wiring check	6 – 55
6.19 Engine Governor (Electronic) / Control System	6 – 56
6.19.1 ECU and connectors cleaning	6 – 56
6.19.2 ECU – checking plug-in connections	6 – 57

6.1 Engine

6.1.1 Engine – barring manually

Preconditions

- Engine is stopped and starting disabled.

Special tools

Designation / Use	Part No.	Qty.
Barring tool	→ TC	
Ratchet	→ TC	

 DANGER	Unguarded rotating and moving engine components. Risk of serious injury — danger to life! <ul style="list-style-type: none"> • Before barring the engine, ensure that nobody is in the danger zone.
--	--

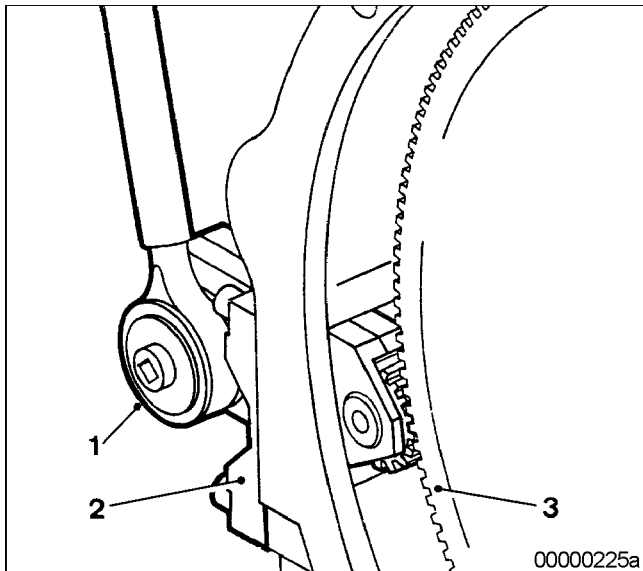

Barring engine manually

1. Remove protective plate.
2. Install barring tool (2).
3. Set ratchet (1) onto barring tool (2).
4. Rotate crankshaft in engine direction of rotation. Apart from the normal compression resistance, there should be no abnormal resistance.
5. For barring-tool removal follow reverse sequence of working steps.

6.1.2 Engine – barring with starting system

Special tools

Designation / Use	Part No.	Qty.
Connector pliers	→ TC	

 DANGER	Unguarded rotating and moving engine components. Risk of serious injury - danger to life! <ul style="list-style-type: none"> • Before barring or starting the engine, ensure that nobody is in the danger zone. • After working on the engine, check that all protective devices have been reinstalled and all tools removed from the engine.
--	---

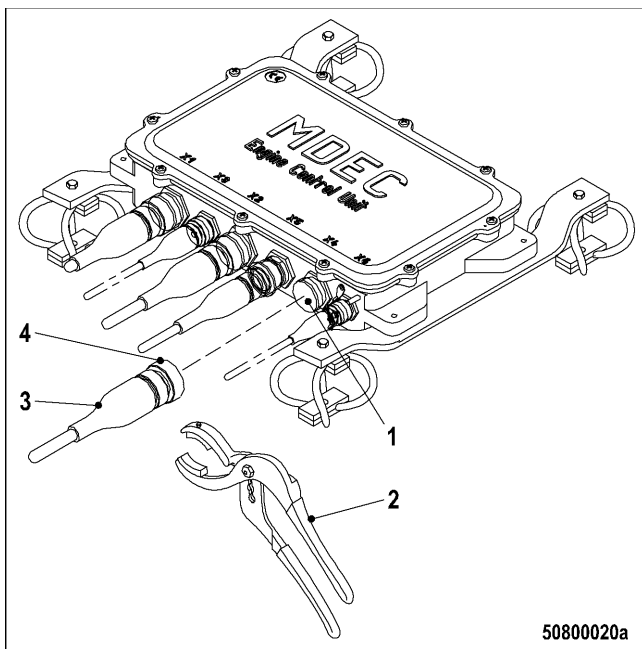

Barring engine with starting system

1. Disengage the bayonet ring-nut (4) of connector X4 with connector pliers (2) and withdraw connector (3) from ECU.
2. Bar engine in unloaded condition: Press START button.
3. Let the crankshaft rotate until oil pressure is indicated.
4. Engine start is automatically interrupted when specified starting period is expired. If necessary, re-start the engine after approx. 20 seconds.
5. Plug connector X4 (3) and use connector pliers (2) to secure the bayonet ring (4) by turning it clockwise until it latches into place.

6.1.3 Engine test run



DANGER

Unguarded rotating and moving engine components.

Risk of serious injury — danger to life!

- Before barring or starting the engine, ensure that nobody is in the danger zone.



WARNING

Engine noise above 85 dB (A).

Risk of damage to hearing!

- Wear ear protectors.

Engine test run

1. Start engine (→ Page 3 – 2).
2. Perform test run at not below 1/3 load and at least until steady-state temperature is reached.
3. Carry out operational checks (→ Page 3 – 4).
4. Stop engine (→ Page 3 – 5).

6.2 Cylinder Liner

6.2.1 Cylinder-liner endoscopic examination

Preconditions

- Engine is stopped and starting disabled.

Special tools

Designation / Use	Part No.	Qty.
Rigid endoscope, max. diameter: 7 mm	→ TC	

Preparatory steps

1. Remove cylinder-head cover (→ Page 6 – 13).
2. Remove injector (→ Page 6 – 15).

Bringing the piston to BDC position

1. Use the barring tool to rotate the crankshaft until the crank pin of the cylinder to be inspected is at BDC position.
2. Insert the endoscope through the cylinder-head injector bore into the combustion chamber.

Findings	Task
<ul style="list-style-type: none"> • Thin carbon deposits around the carbon-residue control ring • Light, localized additive deposits on upper surface • Polished spots on lower edge • Ring of oil deposits in the area between the positions of the upper piston-ring and the lower edge of the carbon-residue control ring • Start of traces left by upper piston ring • Bright surface round circumference • Even honing pattern without complaint • Start of traces left by lower cooling-oil bores • Wear pattern appears to be darker 	No measures necessary.
<ul style="list-style-type: none"> • Oxidation discoloration of even or uneven intensity. • Start and end of discolored areas have no clear edges and do not extend over the whole stroke length • Discolored areas become lighter in upper part of cooling bore; rest of circumference without complaint • Piston-ring set without complaint 	Further endoscope check necessary during maintenance work.
<ul style="list-style-type: none"> • In addition to bright discolorations (which are not critical for engine operation), evidently darker "black zones" all over the running surface, beginning at upper-piston-ring TDC position • Overheating discoloration in piston stroke direction with damaged honing pattern • Piston rings show overheating discoloration 	Cylinder liner must be replaced. Contact Service.

Cylinder-liner endoscopic examination

1. Assess findings of endoscopic examination using the above table.
2. For description of findings on cylinder liner surface use the specified terms (→ Page 6 – 5).
3. Depending on the findings:
 - Do not take any measures, or
 - Conduct endoscopic examination of another liner in the course of maintenance work; or
 - Contact Service: Cylinder liner must be replaced.

Final steps

1. Install injector (→ Page 6 – 15).
2. Install cylinder-head cover (→ Page 6 – 13).

6.2.2 Instructions and comments on endoscopic and visual examination of cylinder liner

Terms used for endoscopic examination

Use the terms listed below to describe the condition of the cylinder-liner surface in the endoscopic examination report.

Minor dirt scores	Light scoring can take place during the assembly of a new engine (honing products, particles, broken-off burrs). Removed cylinders clearly show such scoring on the running surface under endoscope magnification. Cannot be felt with the fingernail. Findings not critical.
Single scores	Clearly visible scores from hard particles. They usually start in the TDC area and cross through the hone pattern in the stroke direction. Findings not critical.
Scored area	These areas consist of scorings next to one another of different length and depth. In most cases, they are found at the 6–o'clock and 12–o'clock positions (inlet/exhaust) along the transverse engine axis. Findings not critical.
Smoothened area	Smoothened areas are on the running surface but almost the whole honing pattern is still visible. Smoothened areas appear brighter and more brilliant than the surrounding running surface. Findings not critical.
Polished area	Polished areas are on the running surface and show local removal of the honing pattern. Grooves from honing process are not visible any more.
Discoloration	This is caused by oxidation (surface discoloration through oil or fuel) and temperature differences around the liner. It appears rather darker within the honed structure in contrast to the bright metallic running surface. The honing pattern is undisturbed. Discolorations extend in stroke direction and may be interrupted. Findings not critical.
Corrosion fields / spots	Corrosion fields / spots result from water (condensed water) with the valves in the overlap (open) position. They are clearly visible due to the dark color of the honing groove bottom. This corrosion is not critical unless there are corrosion pittings.
Black lines	Black lines are a step towards to heat discoloration. They are visible as a clear discoloration from TDC to BDC in the running surface and the start of localized damage to the honing pattern. Cylinders with a number of black lines around the running surface have limited service life and should be replaced.
Discolorations (Heat)	These are caused by a disturbance in the liner / ring tribosystem. Usually they run over the whole ring-travel area (TDC/BDC), starting at the first TDC-ring and becoming more visible towards the second TDC-ring . The honing pattern is usually not visible any more and has a clearly defined (straight) edge to the undisturbed surface. The damaged surface is usually discolored. The circumferential length varies. Liners with heat discoloration starting in the TDC-ring 1 have to be replaced.
Corrosion	Corrosion traces have irregular circumferential length and depth. They can be caused by either the piston skirt or crown. The material deposit on the liner (smear) shows heavy discoloration and heavy scoring. Replace liner.

Evaluation of findings and further measures

The findings in the start phase of oxidation discoloration and heat discoloration are similar. A definite opinion can first be made after a careful inspection and reference to the above criteria. To avoid unnecessary disassembly work, it is recommended that another inspection be carried out after further operation of the engine.

6.3 Crankcase Breather

6.3.1 Crankcase breather – oil separator replacement and diaphragm check

Preconditions

- Engine is stopped and starting disabled.

Special tools

Designation / Use	Part No.	Qty.
Torque wrench	→ TC	

Spare parts

Designation / Use	Part No.	Qty.
Filter element	→ SPC	
Diaphragm	→ SPC	
O-ring	→ SPC	

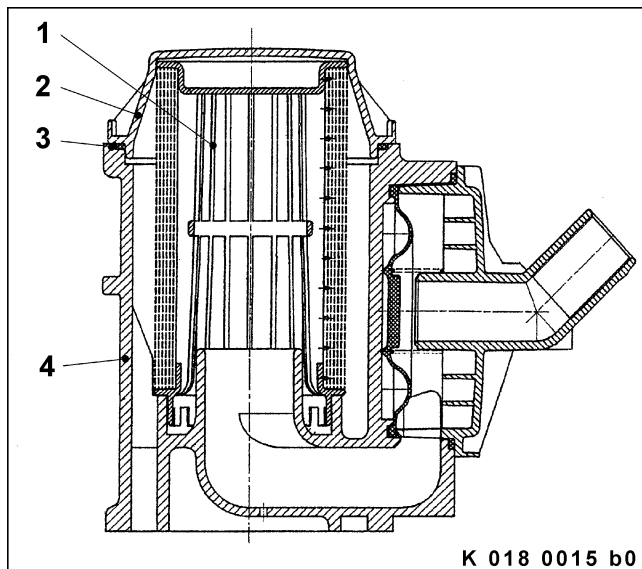

Oil separator replacement

1. Remove cover (2) with O-ring (3).
2. Remove filter element (1) from housing (4).
3. Insert new filter element into housing (4) observing correct installation position, and fit cover (2) with new sealing ring.
4. Tighten screws of cover (2) to 6 Nm + 2 Nm.
5. Replace filter elements of further oil separators in the same way.

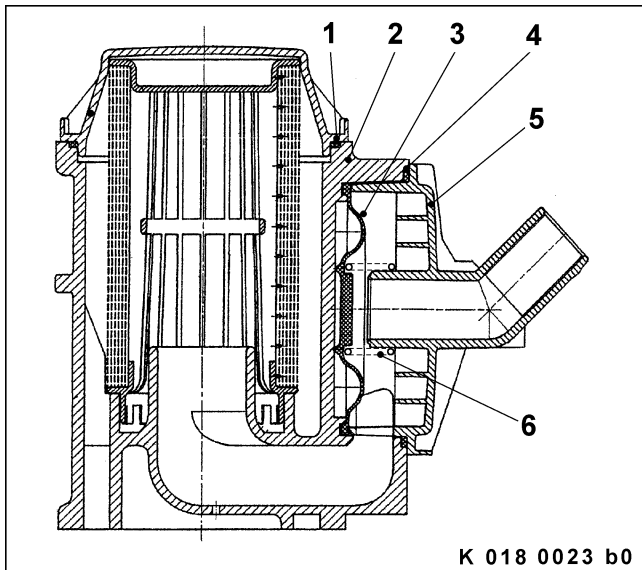

Diaphragm check

1. Remove cover (5).
2. Take off spring (6), seal (4) and diaphragm (3).
3. Check diaphragm (3) for damage.
4. Replace diaphragm if damaged.
5. Mount diaphragm (3) on housing (2).
6. Install new seal (4) and spring (6) together with cover (5).
7. Tighten screws of cover (5) to 6 Nm + 2 Nm.
8. Check diaphragms in further oil separators in the same way.

6.4 Valve Gear

6.4.1 Valve gear lubrication

Preconditions

- Engine is stopped and starting disabled.

Material

Designation / Use	Part No.	Qty.
Engine oil	→ FLS	

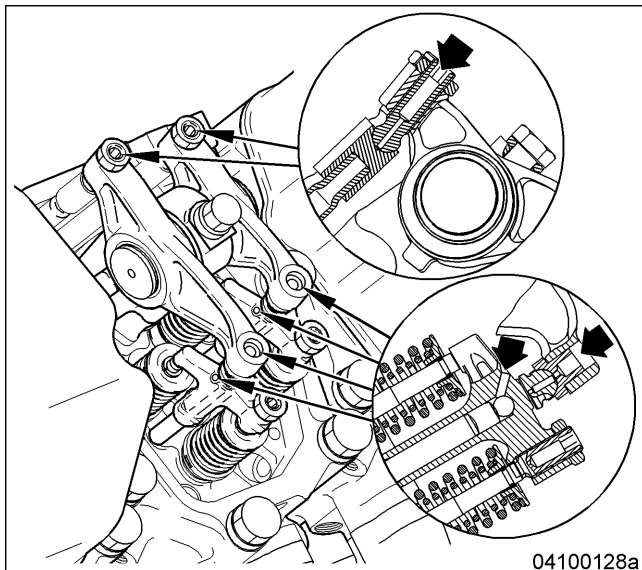

Valve gear lubrication

1. Remove cylinder-head covers (→ Page 6 – 13).
2. Fill oil chambers of valve bridges with oil.
3. Fill oil chambers of rocker arms and adjusting screws with oil.
4. Install cylinder-head covers (→ Page 6 – 13).

6.4.2 Valve clearance check and adjustment

Preconditions

- Engine is stopped and starting disabled.
- Engine coolant temperature is max. 40 °C.
- Valves are closed.

Special tools

Designation / Use	Part No.	Qty.
Feeler gauge	→ TC	
Torque wrench	→ TC	
Allen key	→ TC	
Open end spanner	→ TC	

Preparatory steps

1. Remove cylinder-head cover (→ Page 6 – 13).
2. Install barring tool (→ Page 6 – 1).

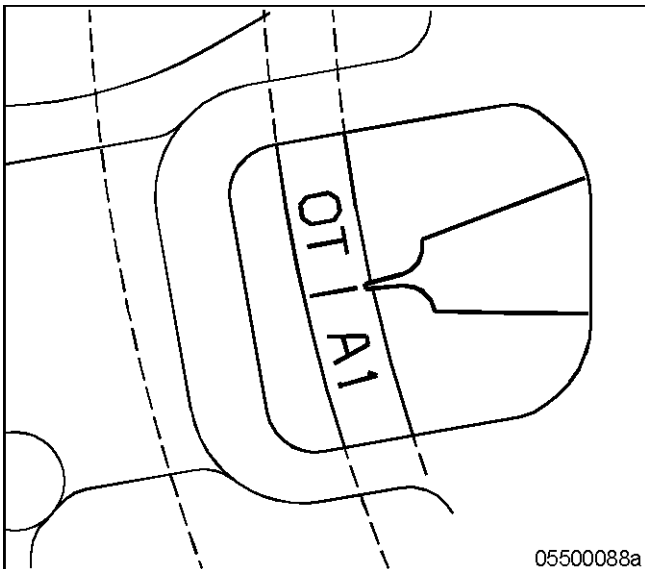

3. Rotate crankshaft with barring tool in engine direction of rotation until marking "OT-A1" and pointer are aligned.

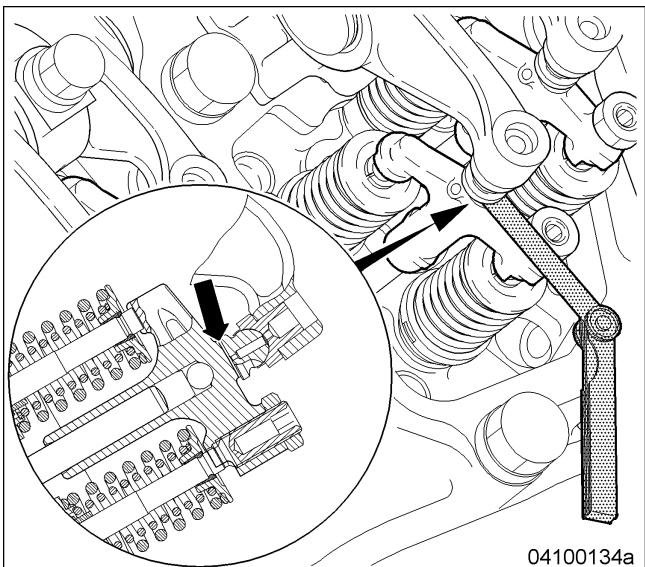

Checking valve-bridge balance

1. Prior to adjusting valve clearance, check valve-bridge balance on all valve bridges.
2. Use feeler gauge to determine the distance between valve bridge and rocker arm.

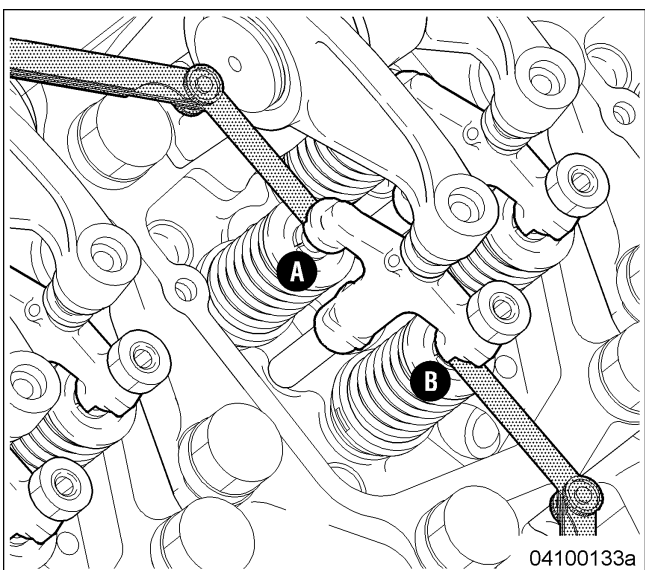

3. Insert feeler gauge with determined value between valve bridge and valve-stem end (A).
4. At the opposite valve-stem end (B), a feeler gauge thicker by 0.05 mm should not fit, otherwise adjust valve bridge.

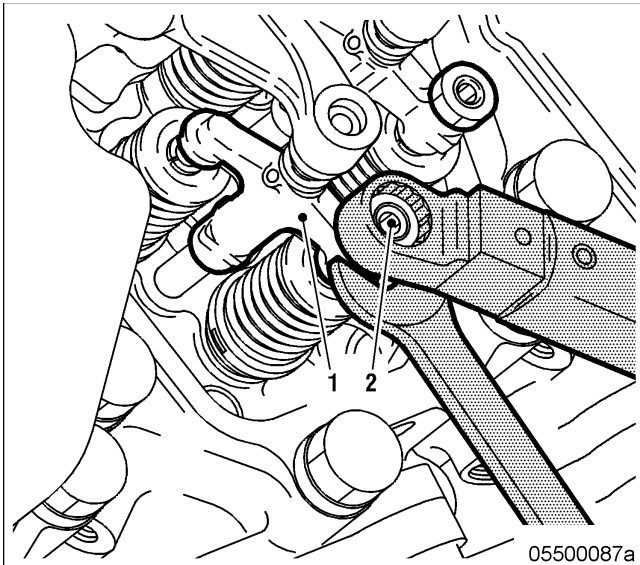

Valve-bridge balance adjustment

1. Hold valve bridge (1) firmly in position with open-end spanner and release locknut (2).

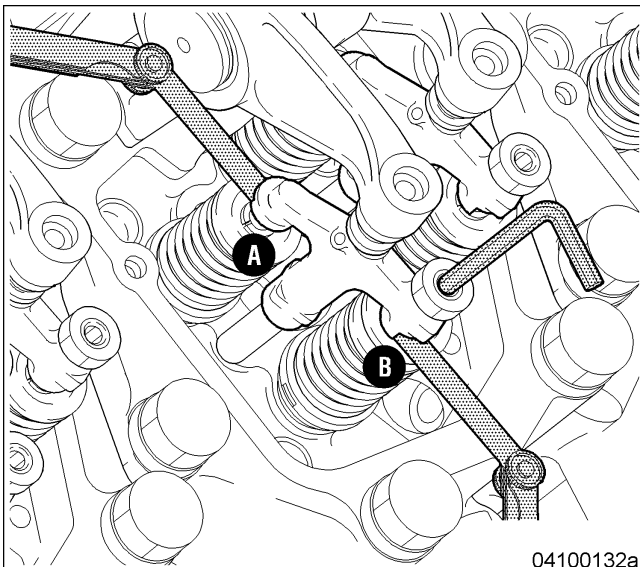

2. Use feeler gauge to determine the distance between valve bridge and rocker arm.
3. Place one feeler gauge (of the determined value) each between valve bridge and the two valve-stem ends (A) and (B).
4. Turn adjusting screw so that both feeler gauges can be just pulled through.
5. Hold adjusting screw securely in position with Allen key and fit locknut by hand on valve bridge.
6. Replace or rectify adjusting screws which do not move freely.

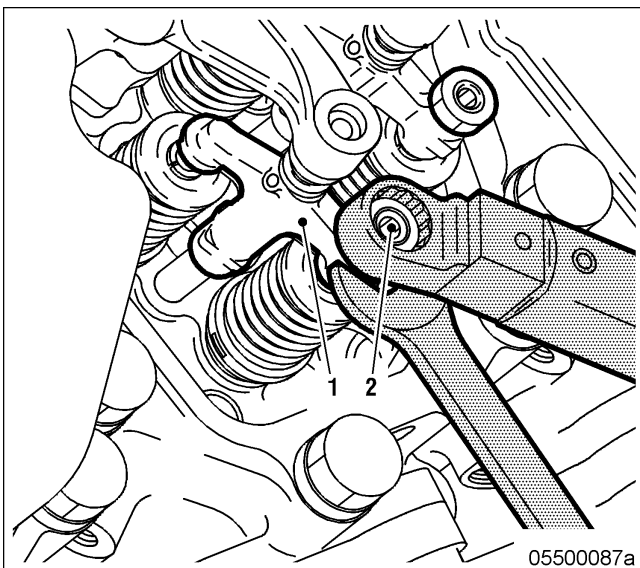

7. Tighten locknut (2) to 35 Nm + 5 Nm, holding valve bridge (1) in position with open-end spanner.
8. Check valve-bridge balance again.

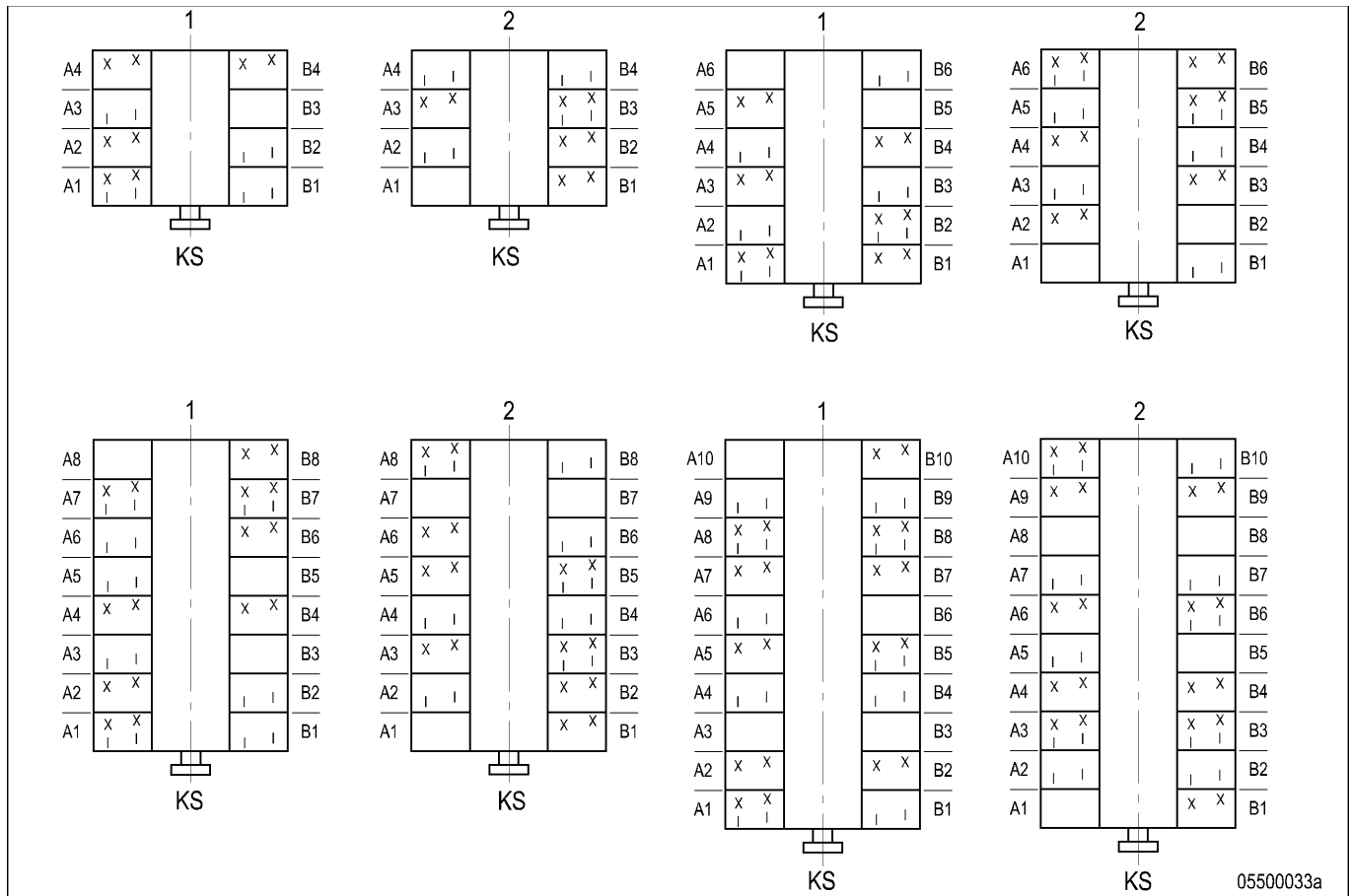

- 1 Cylinder A1 is in firing TDC
 2 Cylinder A1 is in overlap TDC
 I Inlet valve
 X Exhaust valve

Adjusting valve clearance in two crankshaft positions

1. Check TDC position of piston in cylinder A1:
 - If the rocker arms are unloaded on cylinder A, the piston is in firing TDC.
 - If the rocker arms are loaded on cylinder A, the piston is in overlap TDC.
2. Check valve clearance with cold engine:
 - Inlet valves (long rocker arm) = 0.2 mm
 - Exhaust valves (short rocker arm) = 0.5 mm
3. Check all valve clearances at two crankshaft positions (firing and overlap TDC for cylinder A1) as per diagram.
4. Use feeler gauge to determine the distance between valve bridge and rocker arm.
5. If the deviation from the reference value exceeds 0.1 mm, adjust valve clearance.

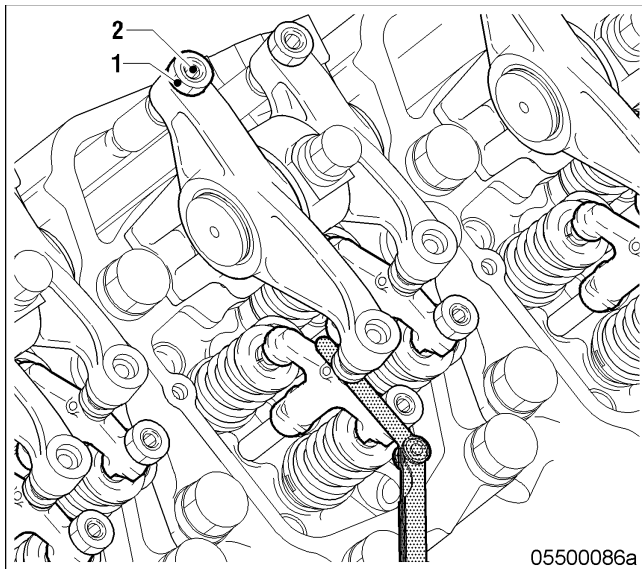

Valve clearance adjustment

1. Release locknut (1).
2. Insert feeler gauge between valve bridge and rocker arm.
3. Using Allen key, set adjusting screw (2) so that the specified valve clearance is provided.
4. Feeler gauge must just pass through the gap.
5. Tighten locknut (1) to $90 + 9$ Nm, holding adjusting screw (2) firm.
6. Replace or rectify adjusting screws and/or locknuts which do not move freely.
7. Check valve clearance.

Final steps

1. Remove barring tool (→ Page 6 – 1).
2. Install cylinder-head cover (→ Page 6 – 13).

6.4.3 Cylinder-head cover removal and installation

Preconditions

- Engine is stopped and starting disabled.

Special tools

Designation / Use	Part No.	Qty.
Torque wrench	→ TC	

Spare parts

Designation / Use	Part No.	Qty.
Gasket	→ SPC	

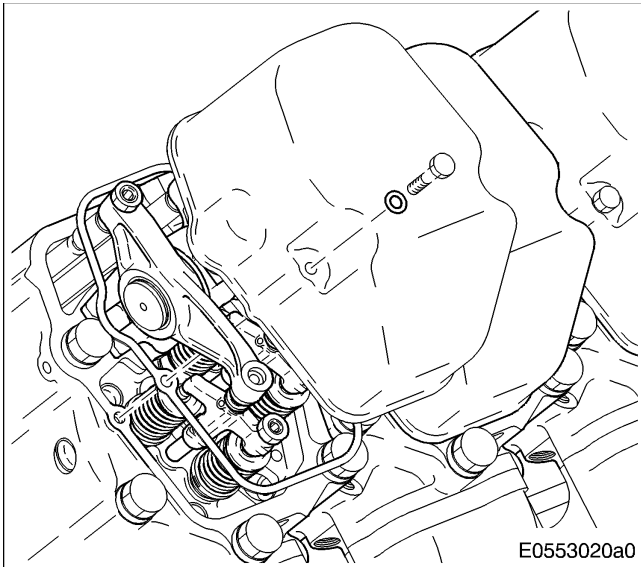

Cylinder-head cover removal

1. Clean very dirty cylinder head covers prior to removal.
2. Remove screws.
3. Remove cylinder head cover with gasket from cylinder head.

Cylinder-head cover installation

1. Clean mating faces.
2. Check condition of gasket, replace if necessary.
3. Place gasket and cylinder head cover on cylinder head.
4. Install screws and tighten to 42 Nm.

6.5 Fuel Injector

6.5.1 Injector replacement

Spare parts

Designation / Use	Part No.	Qty.
Injector	→ SPC	

Remove injector and install new one (→ Page 6 – 15).

6.5.2 Injector removal and installation

Preconditions

- Engine is stopped and starting disabled.

Special tools

Designation / Use	Part No.	Qty.
Puller for injector removal	→ TC	
Puller bracket	→ TC	
Force-in lever for injector installation	→ TC	
Lever for force-in lever	→ TC	
Injector installation jig	→ TC	
Slotted screwdriver	→ TC	
Torque wrench	→ TC	

Material

Designation / Use	Part No.	Qty.
Petroleum jelly	→ FLS	



WARNING

Fuels are combustible.

Risk of fire and explosion!

- Avoid naked flames, electrical sparks and ignition sources.
- Do not smoke.

Preparatory steps

1. Shut off fuel supply to engine.
2. Remove cylinder-head cover (→ Page 6 – 13).

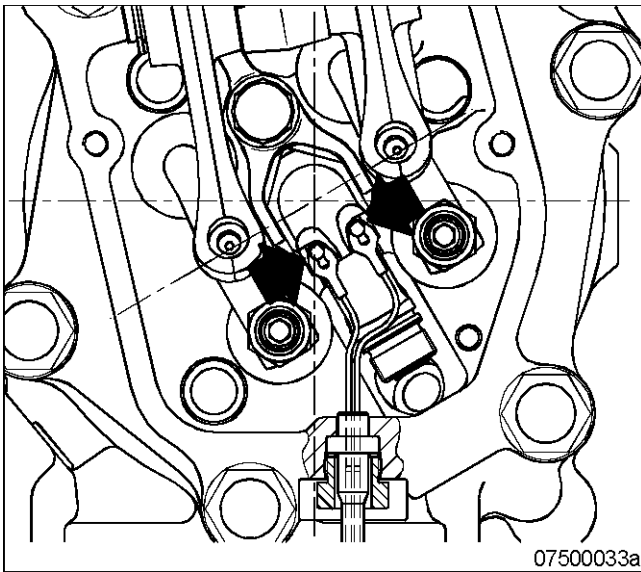

Injector removal

1. Release the cable terminal threaded connection on the injector and remove cable terminals.

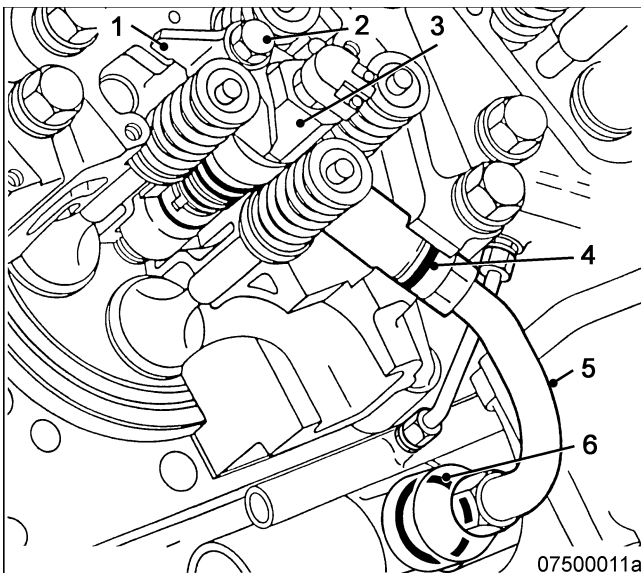

2. Remove screw (2) and take off hold-down clamp (1).
3. Remove HP fuel line (5).

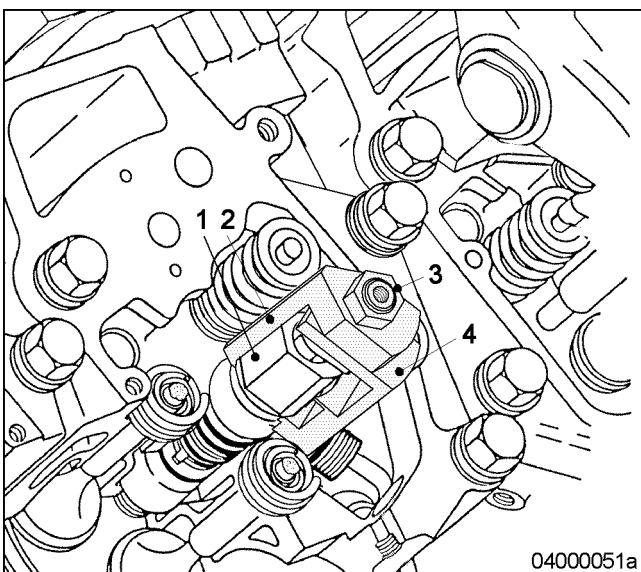

4. Install puller for injector removal. For this purpose, fit part (4) onto injector (1).
5. Slide part (2) over part (4) and turn to correct position - see next illustration.
6. Secure part (2) with nut (3).

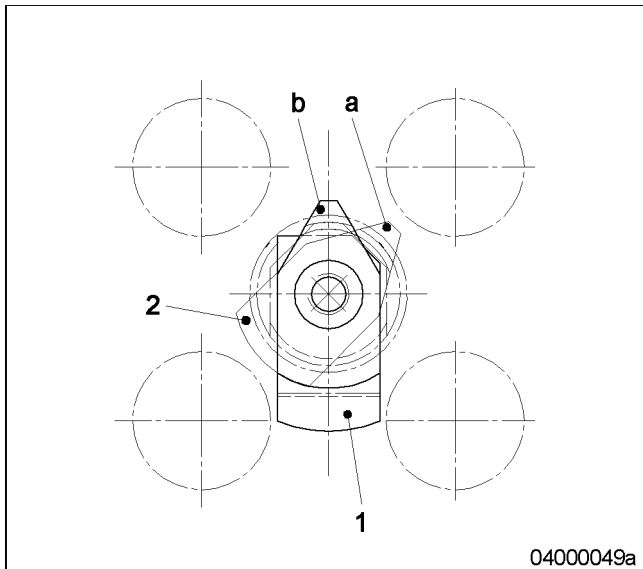

- 7. Initial position of part (2) is position a.
- 8. End position is position b.

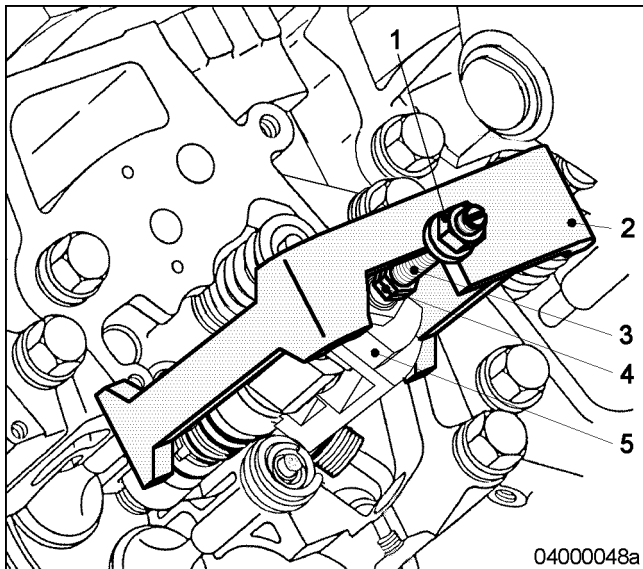

- 9. Install puller bracket (2) for injector removal.
- 10. Turn nut (1) clockwise and withdraw injector.
- 11. Remove puller bracket from injector.

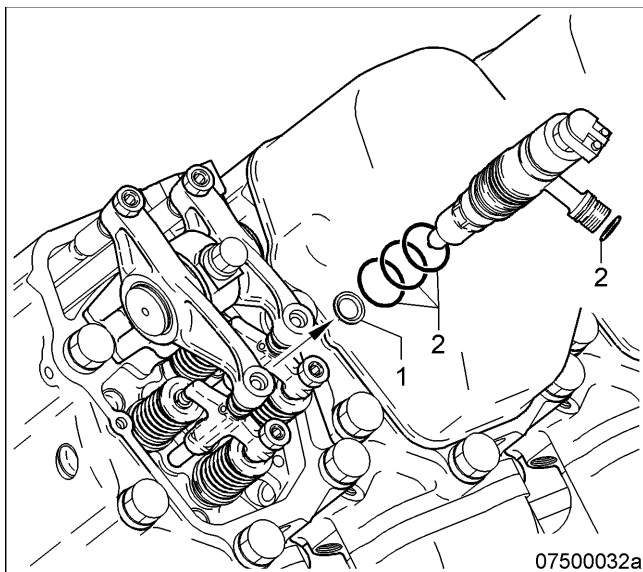

- 12. Remove sealing ring (1) from injector or use a self-made hook to take it out of the cylinder head.
- 13. Remove O-rings (2) from injector.
- 14. Cover all connections and bores, or seal with suitable plugs.

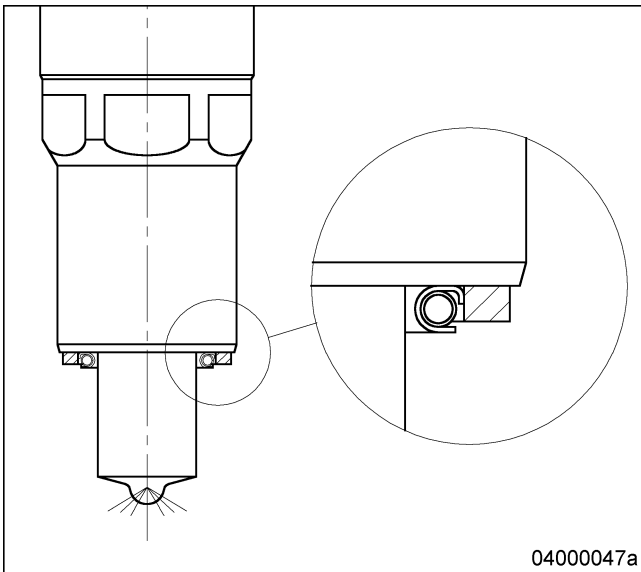

Injector installation

1. Prior to installation, remove all plugs.
2. Coat new O-rings (scope of supply of injector) with petroleum jelly and fit on injector.
3. Fit new sealing ring with petroleum jelly on injector, observe installation position of sealing ring.

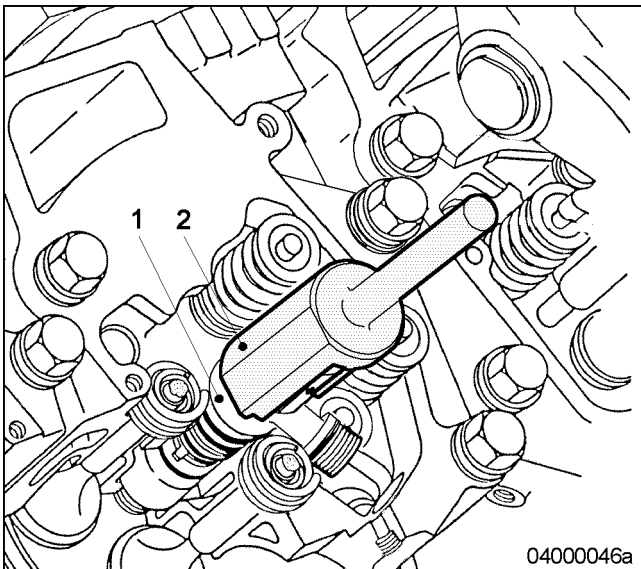

4. Clean sealing surface on cylinder head and protective sleeve.
5. Insert injector (1) into cylinder head, ensuring that the HP fuel line connection is aligned correctly.
6. Fit injector installation jig (2).

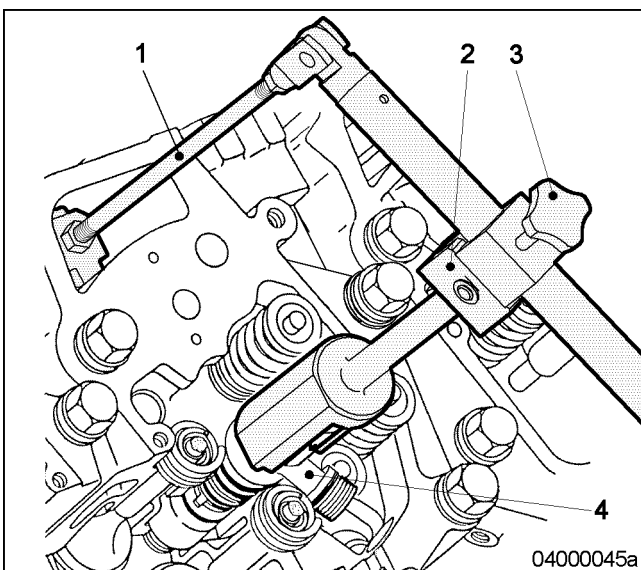

7. Lock force-in lever (1) between pushrods.
8. Release palm grip (3) and move pressure element (2) to correct position of installation jig.
9. Secure palm grip (3) and press injector (4) with force-in lever into cylinder head.
10. Remove force-in tool.

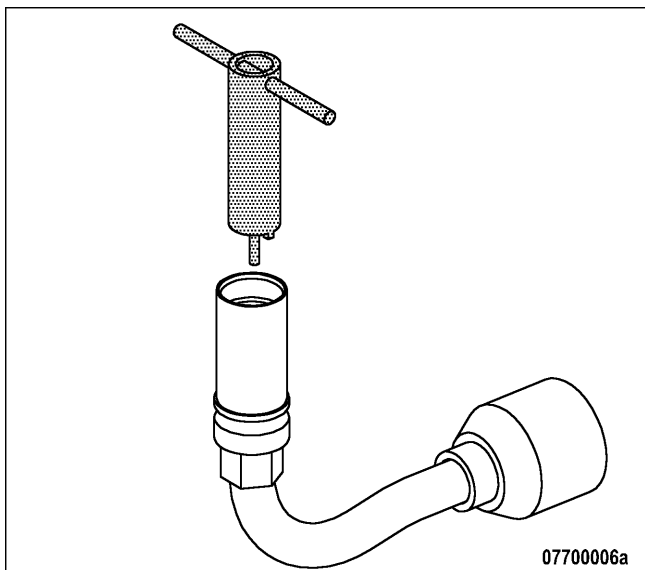

11. Use slotted screwdriver to check thrust ring at both line ends for secure seating.
12. Tighten loose thrust ring to 10 Nm.

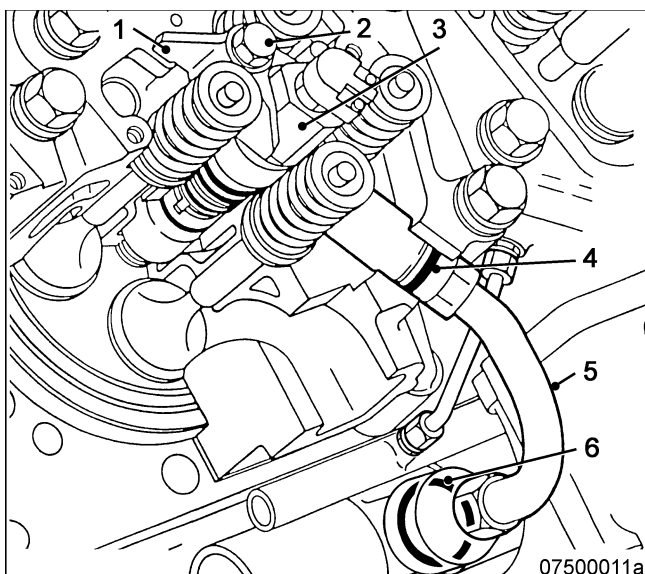

13. Fit hold-down clamp (1) in correct position and install screw (2) by hand.
14. Tighten screw (2) with torque wrench, preliminary tightening torque: 5 Nm to 10 Nm.
15. Coat new O-rings (4) and (6) on with petroleum jelly and fit on HP fuel line (5).
16. Install HP line (5) and tighten preliminarily, tightening torque: 5 Nm to 10 Nm.
17. Tighten screw (2) to 100 + 10 Nm.
18. Tighten HP fuel line to 120 Nm + 12 Nm.

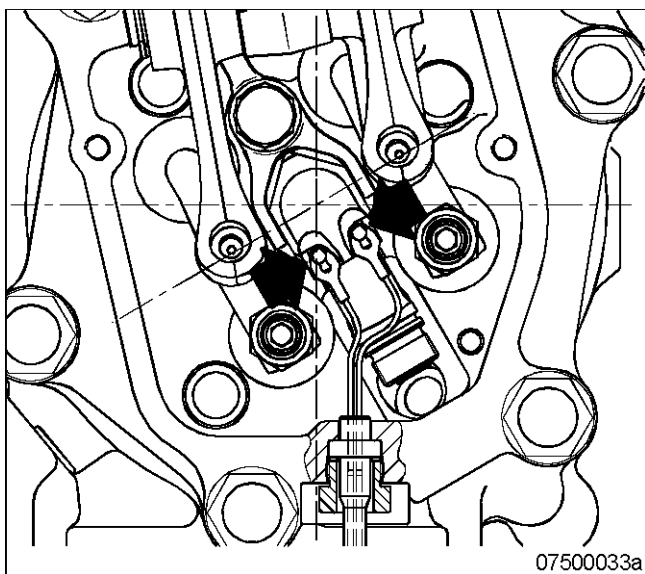

19. Fit cable terminals below the screws on injector and tighten to 1 Nm.

Final steps

1. Install cylinder-head cover (→ Page 6 – 13).
2. Open fuel supply to engine.

6.6 Fuel system

6.6.1 Fuel system venting

Preconditions

- Engine is stopped and starting disabled.

Material

Designation / Use	Part No.	Qty.
Diesel fuel	→ FLS	



WARNING

Fuels are combustible.

Risk of fire and explosion!

- Avoid naked flames, electrical sparks and ignition sources.
- Do not smoke.

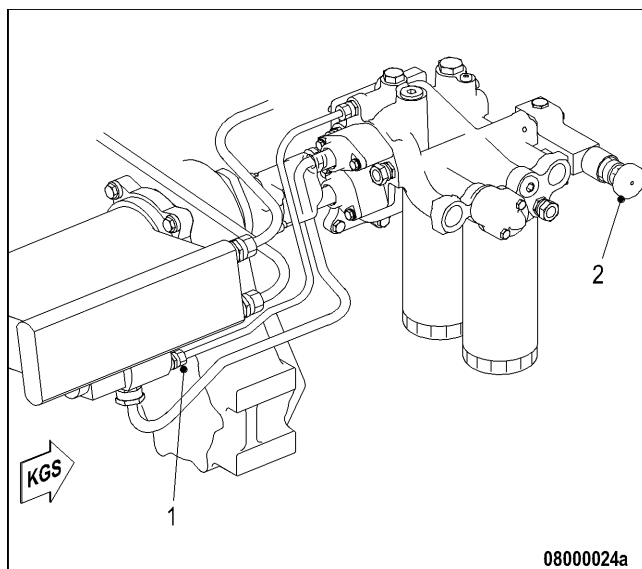

LP fuel system venting

1. Loosen flushing/return line of HP pump at connection (1).
2. Unlock fuel priming pump (2), unscrew handle.
3. Operate the fuel priming pump (2) with the handle until bubble-free fuel comes out of the connection (1).
4. Lock fuel priming pump (2), screw in handle.
5. Verify that fuel priming pump (2) is locked: Handle must be tightened.
6. Tighten connection (1) of flushing/return line.

6.7 Fuel Filter

6.7.1 Fuel filter replacement

Preconditions

- Engine is stopped and starting disabled.

Special tools

Designation / Use	Part No.	Qty.
Strap wrench	→ TC	

Material

Designation / Use	Part No.	Qty.
Diesel fuel	→ FLS	

Spare parts

Designation / Use	Part No.	Qty.
Easy-change filter	→ SPC	



WARNING

Fuels are combustible.

Risk of fire and explosion!

- Avoid naked flames, electrical sparks and ignition sources.
- Do not smoke.

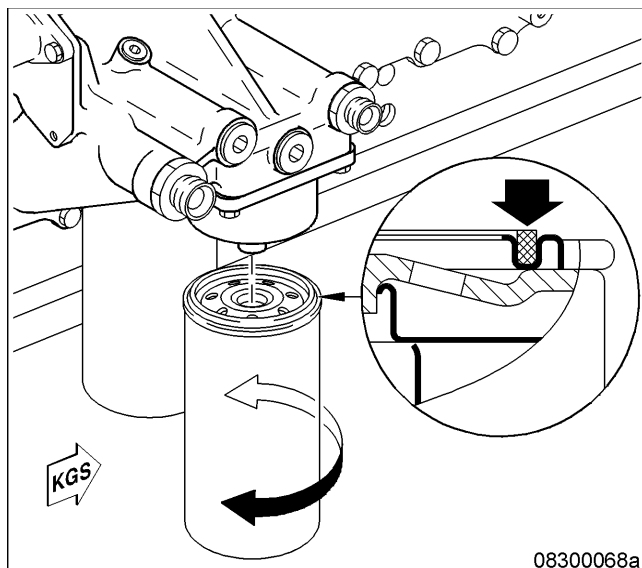

Fuel filter replacement

1. Remove easy-change filter using the strap wrench.
2. Clean the sealing surface of the filter head.
3. Fill the new easy-change filter with clean fuel.
4. Install and tighten new filter by hand.
5. Vent fuel system (→ Page 6 – 21).
6. Replace further easy-change filters in the same way.

6.7.2 Fuel prefilter cleaning

Preconditions

- Engine is stopped and starting disabled.

Material

Designation / Use	Part No.	Qty.
Diesel fuel	→ FLS	

Spare parts

Designation / Use	Part No.	Qty.
Sealing ring	→ SPC	



WARNING

Fuels are combustible.

Risk of fire and explosion!

- Avoid naked flames, electrical sparks and ignition sources.
- Do not smoke.

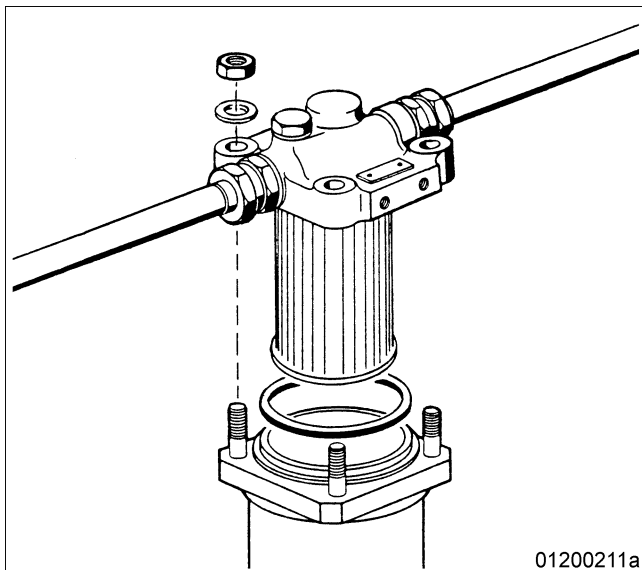

Fuel prefilter cleaning

1. Shut off fuel supply.
2. Remove nuts from filter head.
3. Take off filter housing and drain fuel into appropriate container.
4. Remove filter-element securing nut and remove filter element by pulling it downwards.
5. Wash filter element in clean fuel using a smooth brush.
6. Wash filter housing with clean fuel.
7. Insert filter element into filter housing and secure with nut.
8. Place new sealing ring into groove in filter head.
9. Fit cover with seal and secure it with nuts crosswise.
10. Open fuel supply.

6.7.3 Fuel prefilter – differential pressure check and adjustment of gauge



DANGER

Unguarded rotating and moving engine components.

Risk of serious injury – danger to life!

- Take special care when working on a running engine.



WARNING

Engine noise above 85 dB (A).

Risk of damage to hearing!

- Wear ear protectors.

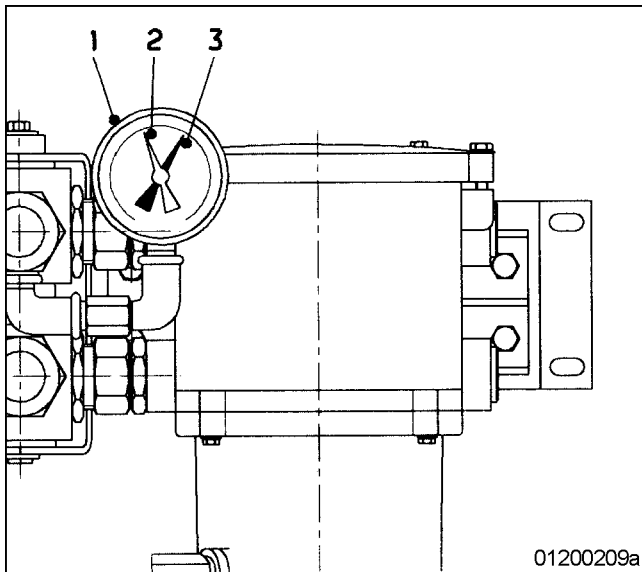

Setting adjustable pointer of differential pressure gauge

1. After installation of a new filter element, align adjustable pointer (2) with pressure-indicating pointer (3) of pressure gauge (1).
2. Verify that differential pressure is within the limit.

Fuel prefilter – checking differential pressure

1. With the engine running at full load or rated power, read off pressure at gauge (1).
2. If differential pressure as indicated between position of adjustable pointer (2) and pressure-indicating pointer (3) of pressure gauge is ≥ 0.3 bar, flush filter element of the cut-in filter (→ Page 6 – 25).

6.7.4 Fuel prefilter – draining

Preconditions

- Engine is stopped and starting disabled.

Material

Designation / Use	Part No.	Qty.
Diesel fuel	→ FLS	

Spare parts

Designation / Use	Part No.	Qty.
Gasket	→ SPC	



Fuels are combustible.

Risk of fire and explosion!

- Avoid naked flames, electrical sparks and ignition sources.
- Do not smoke.

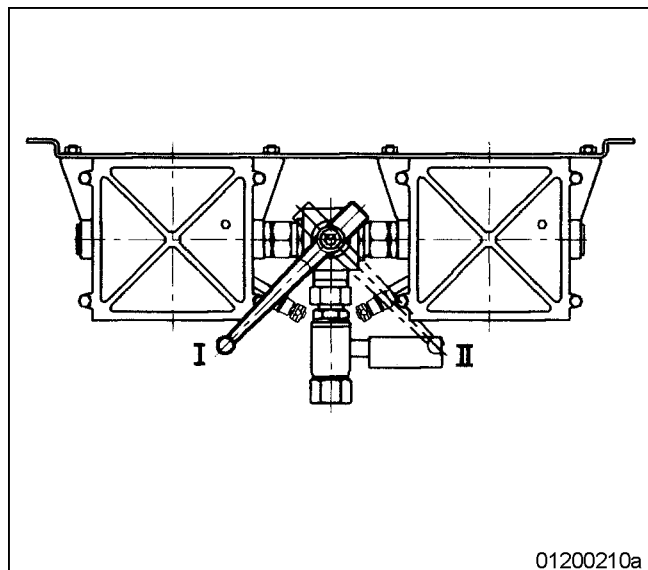

- I Left filter cut in
- II Right filter cut in

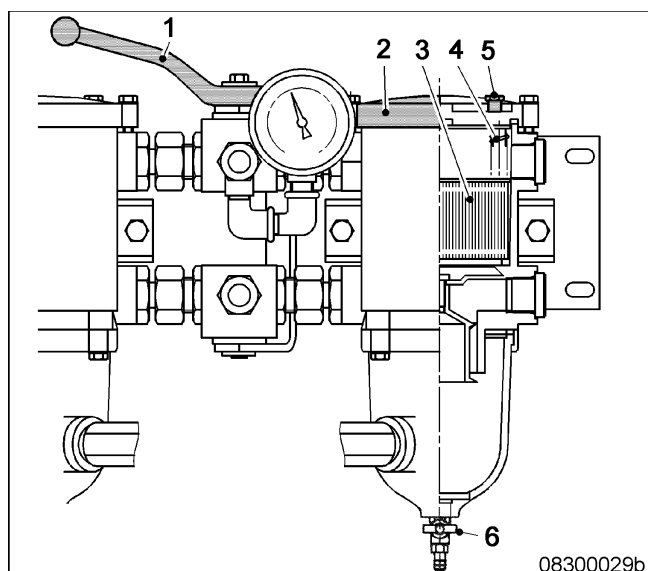

Fuel prefilter – draining

1. Cut out the filter to be drained.

2. Open vent plug (5) of the filter to be drained.
3. Unlock drain cock (6) by pressing toggle and open it.
4. Drain water and contaminants from the filter until pure fuel emerges.
5. Close drain cock (6).
6. Remove screws securing the cover and take off cover (2).
7. Fill filter housing with clean fuel.
8. Place new gasket in cover (2).
9. Fit cover with gasket and secure it with screws.
10. Cut the cut-out filter in again.
11. When fuel emerges from system, close vent plug (5).

6.7.5 Fuel prefilter – flushing

Material

Designation / Use	Part No.	Qty.
Diesel fuel	→ FLS	

Spare parts

Designation / Use	Part No.	Qty.
Gasket	→ SPC	



Unguarded rotating and moving engine components.

Risk of serious injury – danger to life!

- Take special care when working on a running engine.



Fuels are combustible.

Risk of fire and explosion!

- Avoid naked flames, electrical sparks and ignition sources.
- Do not smoke.



Engine noise above 85 dB (A).

Risk of damage to hearing!

- Wear ear protectors.

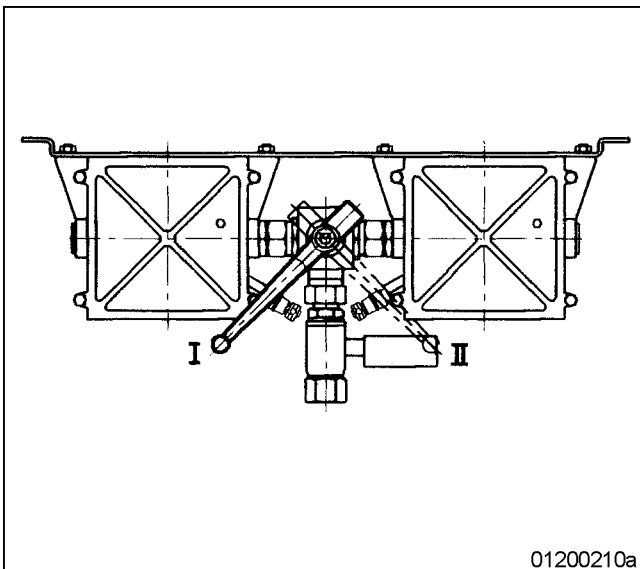

- I Left filter cut in
II Right filter cut in

Fuel prefilter – flushing

1. Cut out the contaminated filter.

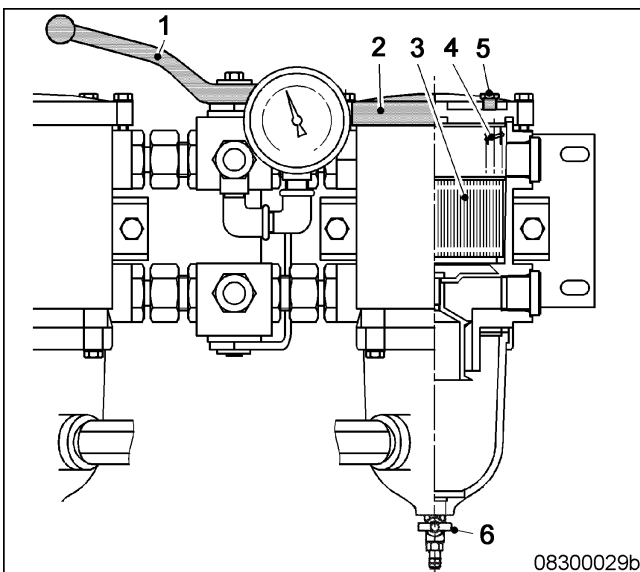

2. Open vent plug (5) of the filter to be flushed.
3. Unlock drain cock (6) by pressing toggle, open it and drain fuel.
Result: Fuel flows from filtered side back to the unfiltered side, flushing the filter deposits downwards out of the filter.
4. Close vent plug (5) and drain cock (6).

Fuel prefilter – filling fuel

1. Stop engine (→ Page 3 – 5) and disable engine start.
2. Remove screws securing the cover and take off cover (2).
3. Fill filter housing with clean fuel.

4. Place new gasket in cover (2).
5. Fit cover with gasket and secure it with screws.
6. Check differential pressure (→ Page 6 – 23).
 Result: If flushing did not lead to an improvement of the differential pressure, replace filter element (→ Page 6 – 27).

6.7.6 Fuel prefilter – filter element replacement

Preconditions

- Engine is stopped and starting disabled.

Material

Designation / Use	Part No.	Qty.
Diesel fuel	→ FLS	

Spare parts

Designation / Use	Part No.	Qty.
Filter element	→ SPC	
Gasket	→ SPC	

 WARNING	Fuels are combustible. Risk of fire and explosion! <ul style="list-style-type: none"> • Avoid naked flames, electrical sparks and ignition sources. • Do not smoke.
---	---

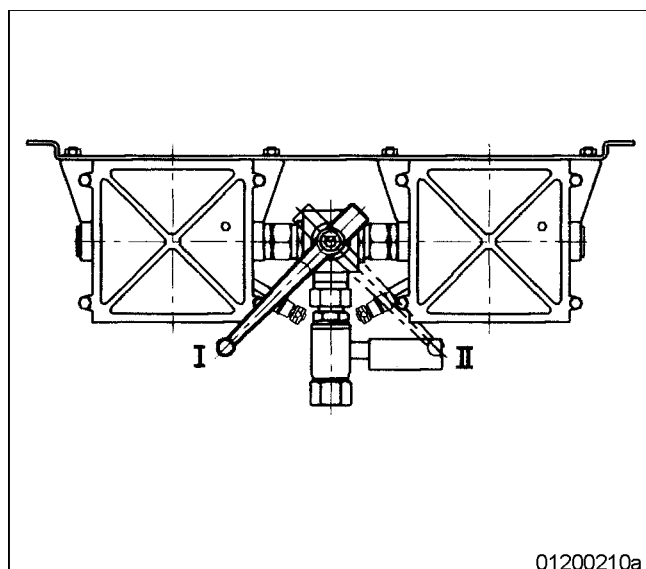

- I Left filter cut in
- II Right filter cut in

Fuel prefilter – filter element replacement

1. Cut out the contaminated filter.

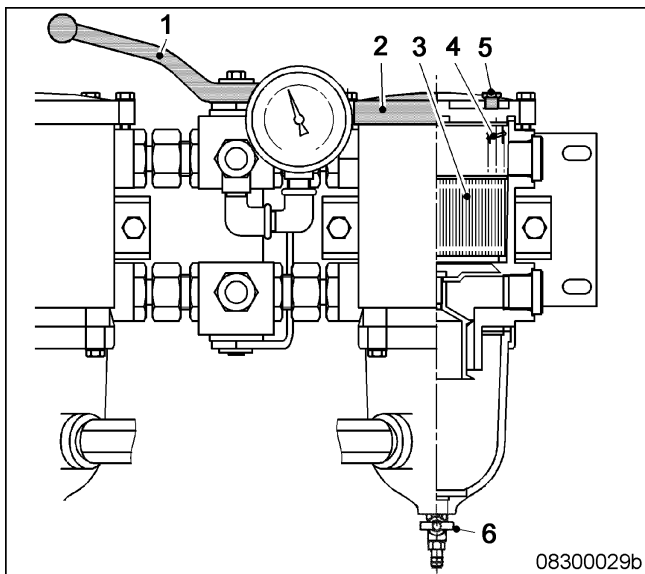

2. Open vent plug (5) of the contaminated filter.
3. Unlock drain cock (6) by pressing toggle and open it.
4. Drain water and contaminants from the filter.
5. Close drain cock (6).
6. Remove screws securing the cover and take off cover (2).
7. Remove spring (4) and filter element (3).
8. Insert new filter element (3) and spring (4).
9. Fill filter housing with clean fuel.
10. Place new gasket in cover (2).
11. Fit cover with gasket and secure it with screws.
12. Cut the cut-out filter in again.
13. Close vent plug (5) when fuel emerges.
14. Align adjustable pointer of differential pressure gauge with pressure-indicating pointer.
(→ Page 6 – 23).

6.8 Charge-Air Cooling, General, Left Side

6.8.1 Intercooler – checking condensate drains for coolant discharge and obstruction



Unguarded rotating and moving engine components.
Risk of serious injury – danger to life!
 • Take special care when working on a running engine.



Engine noise above 85 dB (A).
Risk of damage to hearing!
 • Wear ear protectors.



Compressed air.
Risk of injury!
 • Do not direct compressed-air jet at persons.
 • Wear protective goggles / safety mask and ear protectors.

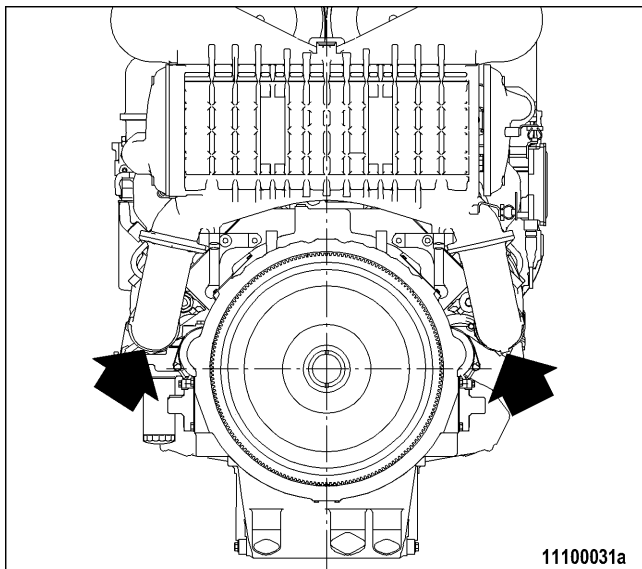

Intercooler – checking condensate drains for coolant discharge and obstructions

1. With the engine running, verify that air emerges from the condensate drain(s) at driving end, left and right engine side. If no air emerges:
2. Clean condensate drain(s) and blow out with compressed air.
3. If a large amount of coolant is continuously discharged, the intercooler is leaking. Contact Service.

Emergency measures prior to engine start with a leaking intercooler

1. Remove injectors (→ Page 6 – 15).
2. Bar engine manually (→ Page 6 – 1).
3. Bar engine with starting system to blow out combustion chambers (→ Page 6 – 1).
4. Install injectors (→ Page 6 – 15).

6.9 Air Filter

6.9.1 Air filter replacement

Spare parts

Designation / Use	Part No.	Qty.
Air filter	→ SPC	

Remove air filter and install new one (→ Page 6 – 30).

Reset signal ring of service indicator (→ Page 6 – 31).

6.9.2 Air filter removal and installation

Preconditions

- Engine is stopped and starting disabled.

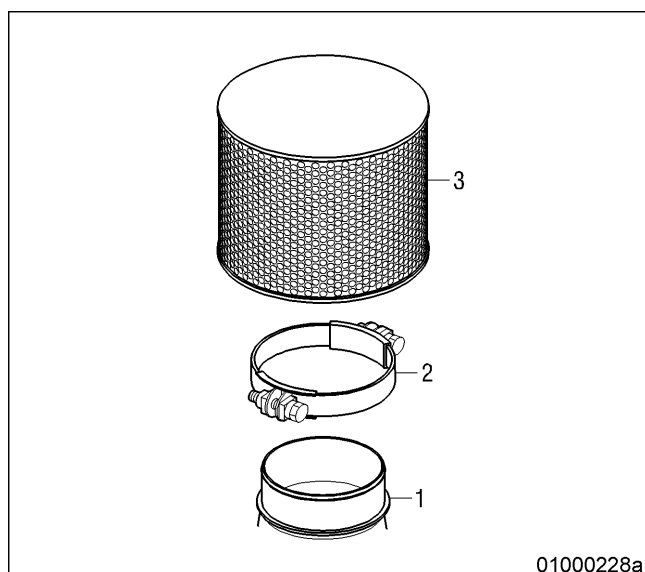

Air filter removal and installation

1. Loosen clamp (2).
2. Remove air filter (3) and clamp (2) from flange of intake housing (1).
3. Verify that there are no objects in the intake housing (1) and clean it.
4. Place new air filter (3) with clamp (2) onto intake housing (1).
5. Tighten clamp (2).

6.10 Air Intake

6.10.1 Service indicator – signal ring position check

Preconditions

- Engine is stopped and starting disabled.

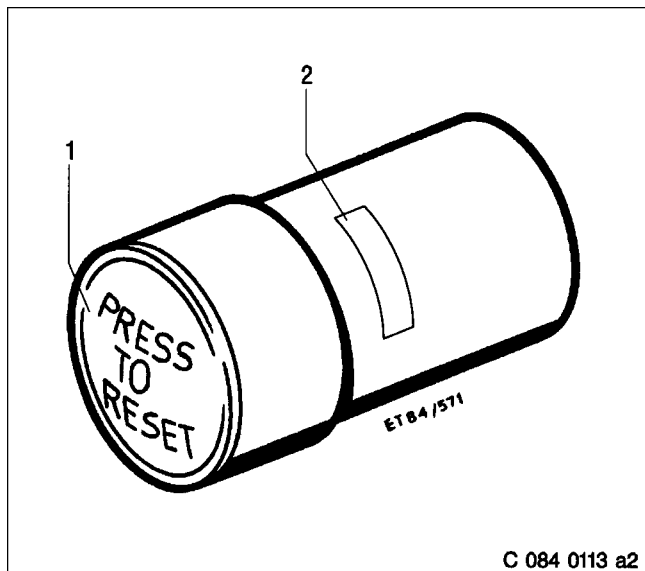

Signal ring position check

1. If the signal ring is completely visible in the control window (2), replace air filter (→ Page 6 – 30).
2. After installation of new filter, press reset button (1).

Result: Engaged piston with signal ring moves back to initial position.

6.11 Starting System

6.11.1 Starter condition check

Preconditions

- Engine is stopped and starting disabled.

Starter condition check

1. Check starter securing screws for secure seating.
2. Tighten loose screw connections.
3. Check wiring (→ Page 6 – 55).

6.11.2 Air starter – manual operation



DANGER

Unguarded rotating and moving engine components.

Risk of serious injury — danger to life!

- Before barring or starting the engine, ensure that nobody is in the danger zone.



WARNING

Engine noise above 85 dB (A).

Risk of damage to hearing!

- Wear ear protectors.

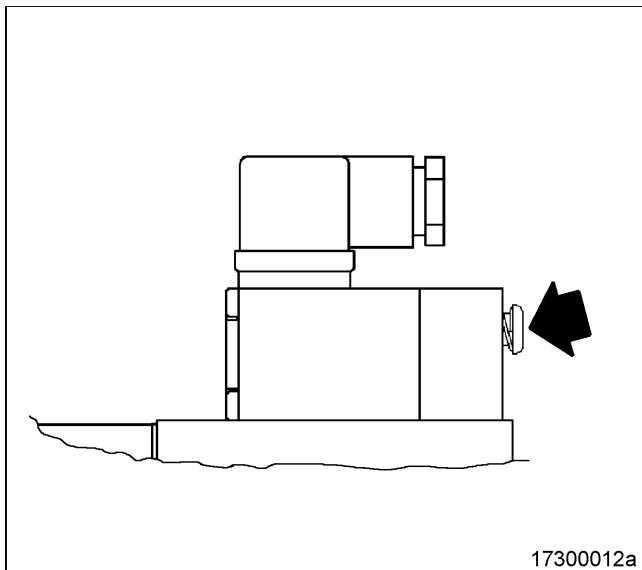

Air starter – manual operation

1. Press pushbutton for manual start and hold it.
2. Allow compressed air to enter the air starter until the engine fires evenly.
3. Release pushbutton.

6.12 Lube Oil System

6.12.1 Engine-oil sample extraction and analysis

Preconditions

- MTU Fluids and Lubricants Specification (A001061/..) is available.

Special tools

Designation / Use	Part No.	Qty.
MTU test kit	→ TC	



Unguarded rotating and moving engine components.

Risk of serious injury – danger to life!

- Take special care when working on a running engine.



Hot engine oil.

Engine oil can contain combustion residues which are harmful to health.

Risk of injury and scalding!

- Wear protective clothing, gloves, and goggles / safety mask.
- Avoid contact with skin.
- Do not inhale oil vapor.



Engine noise above 85 dB (A).

Risk of damage to hearing!

- Wear ear protectors.

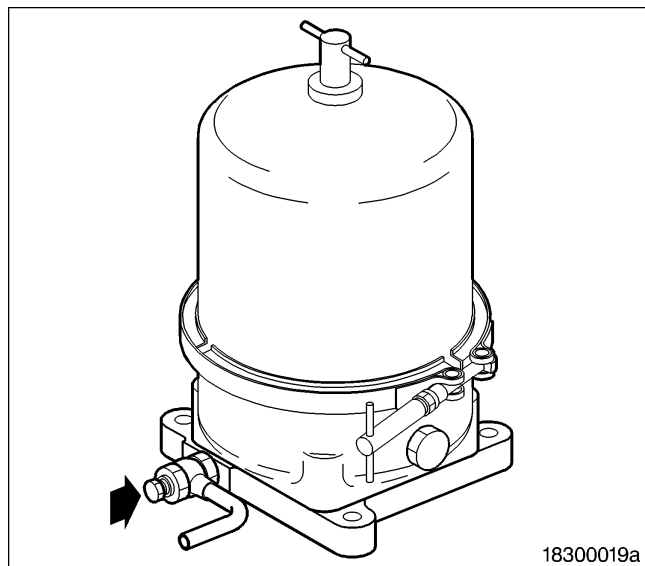

Engine-oil sample extraction and analysis

1. With the engine running at operating temperature, open screw on flange of centrifugal oil filter by 1 to 2 rotations.
2. Drain approx. 2 liters engine oil to flush out the oil sludge.
3. Drain approx. 1 liter engine oil into a clean container.
4. Close screw.
5. Using the equipment and chemicals of the MTU test kit, examine oil for:
 - Dispersion capability (spot test);
 - Water content;
 - Dilution by fuel.

6.12.2 Engine oil change

Preconditions

- Engine is stopped and starting disabled.
- Engine is at operating temperature.
- MTU Fluids and Lubricants Specification (A001061/..) is available.

Material

Designation / Use	Part No.	Qty.
Engine oil	→ FLS	

Spare parts

Designation / Use	Part No.	Qty.
Sealing ring	→ SPC	



WARNING

- Hot engine oil.
Engine oil can contain combustion residues which are harmful to health.
- Risk of injury and scalding!**
- Wear protective clothing, gloves, and goggles / safety mask.
 - Avoid contact with skin.
 - Do not inhale oil vapor.

Oil change without semirotary hand pump: Draining oil at drain plug on oil pan

1. Provide a suitable container in which to collect the oil.
2. Remove drain plug and drain oil.
3. Install drain plug with new sealing ring.
4. Replace engine oil filter (→ Page 6 – 36).

Oil change using semirotary hand pump: Oil extraction

1. Provide a suitable container in which to collect the oil.
2. Extract all oil from oil pan using the hand pump.
3. Replace engine oil filter (→ Page 6 – 36).

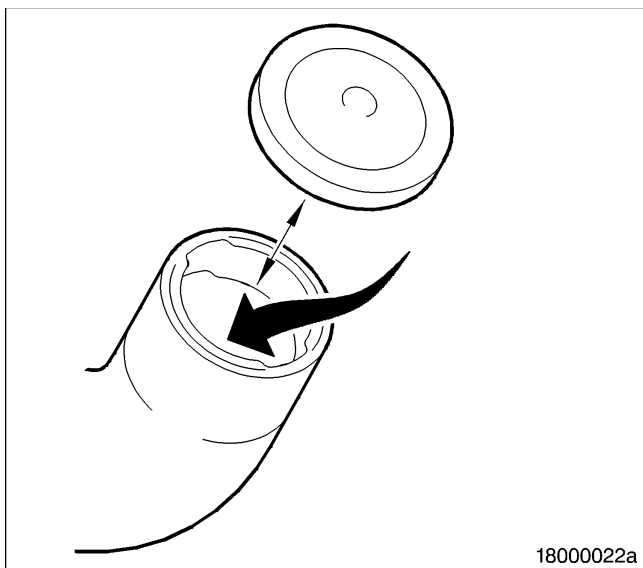

Engine oil system filling

1. Determine amount of engine oil required for oil change (→ Product Summary - Technical Data).
2. Open cover of filler neck.
3. Pour oil in at filler neck up to "max." mark at oil dipstick.
4. Close cover of filler neck.
5. Check oil level (→ Page 6 – 35).
6. After oil change and oil filter replacement, bar engine with starting system (→ Page 6 – 1).

6.12.3 Engine oil level check

Preconditions

- Engine is stopped and starting disabled.

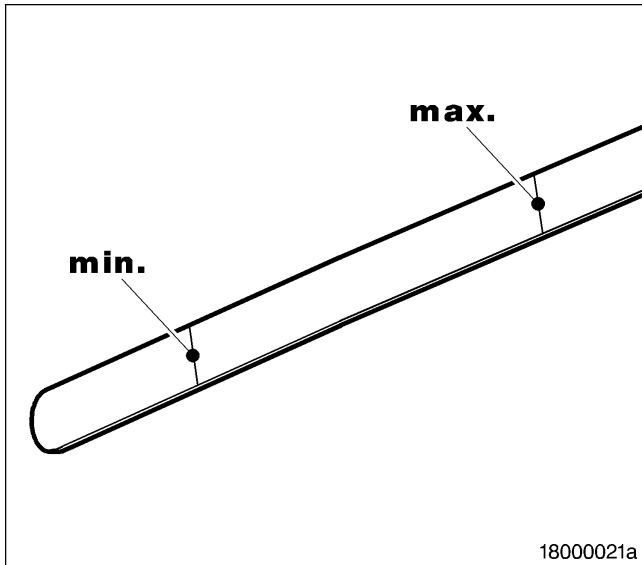

Oil level check prior to engine start

1. Withdraw dipstick from guide tube and wipe it.
2. Insert dipstick into guide tube to stop, withdraw and check oil level.
3. Oil level must be between “min.” and “max.” marks.
4. If necessary, top up to “max.” mark.
(→ Page 6 – 34).
5. Insert dipstick into guide tube to stop.

Oil level check after the engine is stopped

1. 5 minutes after stopping the engine, remove oil dipstick from the guide tube and wipe it.
2. For further steps see: Oil level check prior to engine start.

6.13 Oil Filtration / Cooling

6.13.1 Engine oil filter replacement

Preconditions

- Engine is stopped and starting disabled.

Special tools

Designation / Use	Part No.	Qty.
Strap wrench	→ TC	

Material

Designation / Use	Part No.	Qty.
Engine oil	→ FLS	

Spare parts

Designation / Use	Part No.	Qty.
Oil filter	→ SPC	



WARNING

- Hot engine oil.
Engine oil can contain combustion residues which are harmful to health.
- Risk of injury and scalding!**
- Wear protective clothing, gloves, and goggles / safety mask.
 - Avoid contact with skin.
 - Do not inhale oil vapor.

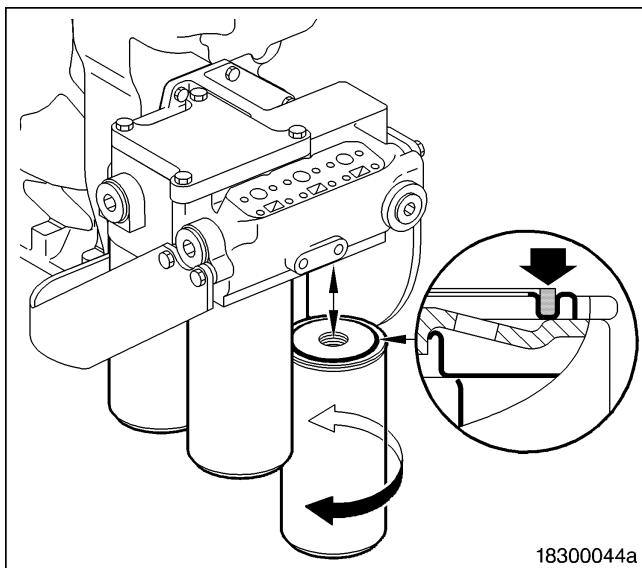

Engine oil filter replacement

1. Remove oil filter using the strap wrench.
2. Clean the sealing surface of the filter head.
3. Check condition of the new sealing ring and coat it with oil.
4. Install and tighten new oil filter by hand.
5. Replace further oil filters in the same way.
6. After each oil change and filter replacement, bar the engine using the starting device (→ Page 6 – 1).
7. Check oil level (→ Page 6 – 35).

6.13.2 Centrifugal oil filter – cleaning and filter-sleeve replacement

Preconditions

- Engine is stopped and starting disabled.

Material

Designation / Use	Part No.	Qty.
Cleaner Hakutex 60	→ FLS	

Spare parts

Designation / Use	Part No.	Qty.
Filter sleeve	→ SPC	
Sealing ring	→ SPC	
Sealing ring	→ SPC	



WARNING

Hot engine oil.
Engine oil can contain combustion residues which are harmful to health.

Risk of injury and scalding!

- Wear protective clothing, gloves, and goggles / safety mask.
- Avoid contact with skin.
- Do not inhale oil vapor.



WARNING

Compressed air.

Risk of injury!

- Do not direct compressed-air jet at persons.
- Wear protective goggles / safety mask and ear protectors.

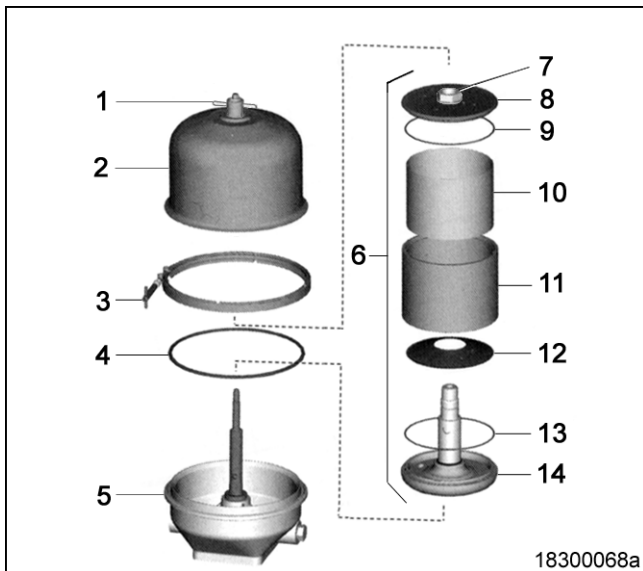

Centrifugal oil filter – cleaning and filter-sleeve replacement

1. Remove clamp (3).
2. Release Tommy nut (1) and take off cover (2).
3. Carefully take off rotor (6), allow oil to drain and remove rotor from housing.
4. Hold rotor (6) firmly and release rotor cap nut (7).
5. Take off rotor cap (8).
6. Remove filter sleeve (10).
7. Measure thickness of oil residues on filter sleeve.
8. If maximum layer thickness of oil residues exceeds 45 mm, shorten maintenance interval.
9. Disassemble rotor tube (11), separator cone (12) and rotor lower section (14).
10. Wash rotor cover (8), rotor tube (11), separator cone (12) and rotor lower section (14) with cleaner and blow out with compressed air.
11. Assemble rotor tube (11), separator cone (12) and rotor lower section (14) with new sealing ring (13).
12. Fit new filter sleeve (10) in rotor tube (11).
13. Mount rotor cap (8) with new sealing ring (9).
14. Tighten rotor cap nut (7) with 35 Nm to 45 Nm.

15. Place rotor (6) in housing (5) and check for ease of movement.
16. Place new sealing ring (4) onto housing (5).
17. Fit cover (2).
18. Tighten Tommy nut (1) by hand.
19. Install clamp (3) and tighten with 8 Nm to 10 Nm.
20. Tighten Tommy nut (1) with 5 Nm to 7 Nm.

6.14 Cooling System, General, HT Circuit

6.14.1 Engine coolant system filling

Preconditions

- Engine is stopped and starting disabled.
- MTU Fluids and Lubricants Specification (A001061/..) is available.

Material

Designation / Use	Part No.	Qty.
Coolant	→ FLS	



Coolant is hot and under pressure.

Risk of injury and scalding!

- Let the engine cool down.
- Wear protective clothing, gloves, and goggles / safety mask.



Cold coolant in hot engine can cause thermal stress.

Formation of cracks in components!

- Fill / top up coolant only into cold engine.

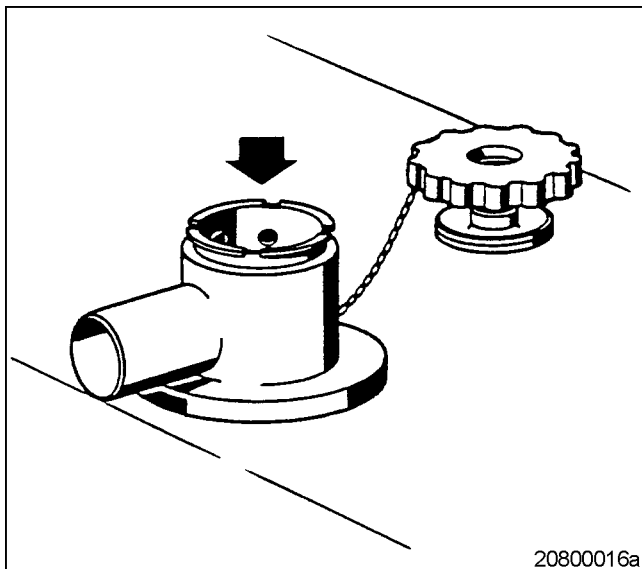

Preparatory steps

1. Turn breather valve of filler neck on coolant expansion tank counterclockwise to first stop and allow pressure to escape.
2. Continue to turn breather valve counterclockwise and remove.

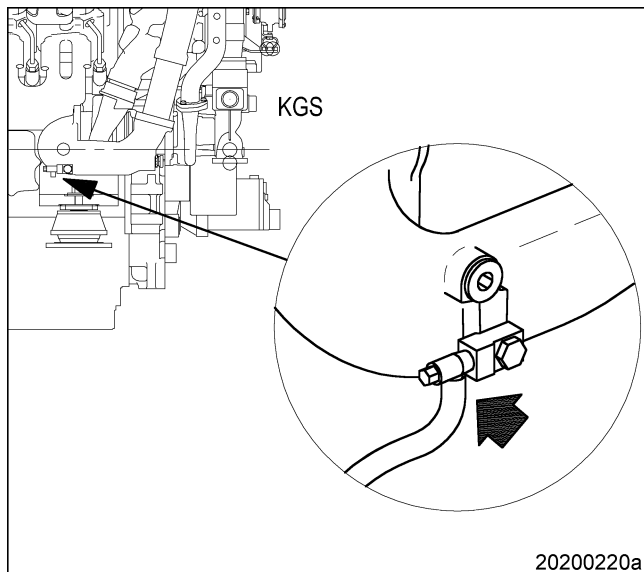

Filling coolant with pump

1. Connect appropriate pump with hose to drain valve.
2. Open drain valve and pump treated coolant into engine, until coolant level reaches lower edge of cast-in eye or marking plate on filler neck.
3. Close drain valve.
4. Disconnect pump and hose.

Filling coolant through filler neck

1. Alternatively: Fill coolant through filler neck on coolant expansion tank until level reaches cast-in eye or marking plate.
2. Check proper condition of breather valve, clean sealing faces if required.
3. Set breather valve onto filler neck and close it.

Final steps

1. Start the engine and operate it at idle speed for some minutes.
2. Check coolant level (→ Page 6–42) and top up, if required.

6.14.2 Engine coolant draining

Preconditions

- Engine is stopped and starting disabled.



Coolant is hot and under pressure.

Risk of injury and scalding!

- Let the engine cool down.
- Wear protective clothing, gloves, and goggles / safety mask.

Preparatory steps

1. Provide an appropriate container to drain the coolant into.
2. Switch off preheating unit.

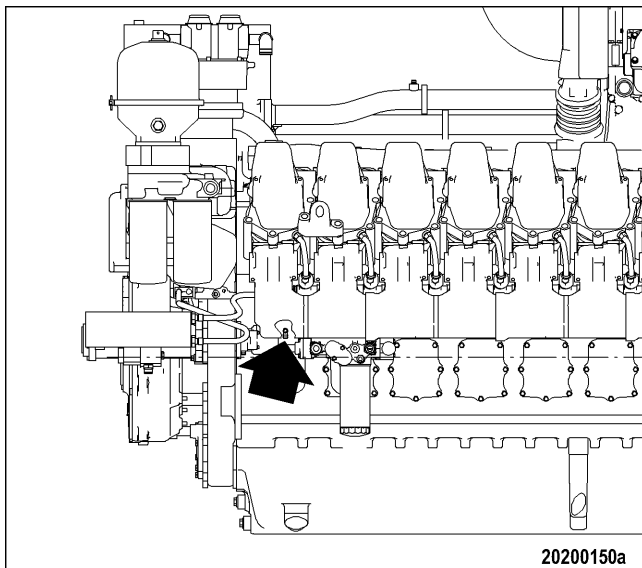
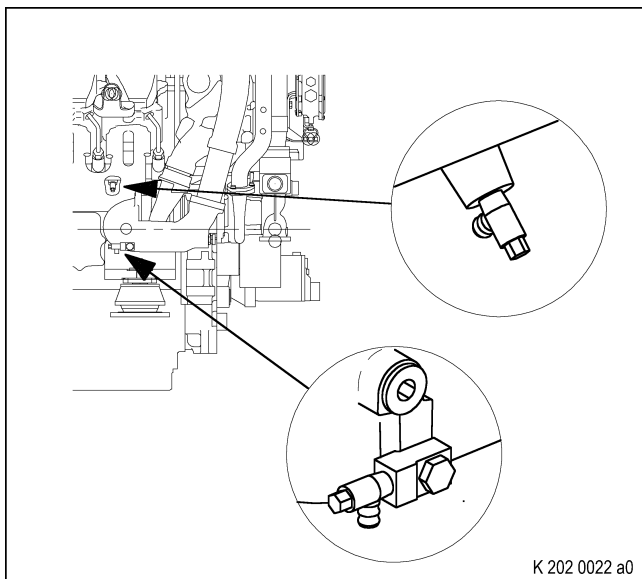

Engine coolant draining

1. Turn breather valve of filler neck on coolant expansion tank counterclockwise to first stop and allow pressure to escape.
2. Continue to turn breather valve counterclockwise and remove.
3. Draw off precipitated corrosion inhibitor oil from the expansion tank through filler neck.
4. Open drain valves and drain plugs and drain coolant at the following points:
 - Preheating unit;
 - HT coolant pump elbow;
 - Crankcase, right side.
5. Additional drain point:
 - Crankcase, left side.
6. Seal all open drain points.
7. Set breather valve onto filler neck and close it.

6.14.3 Engine coolant change

Material

Designation / Use	Part No.	Qty.
Coolant	→ FLS	

Drain engine coolant (→ Page 6 – 40).

Fill engine coolant system (→ Page 6 – 39).

6.14.4 Engine coolant-level check

Preconditions

- Engine is stopped and starting disabled.
- MTU Fluids and Lubricants Specification (A001061/..) is available.



Coolant is hot and under pressure.

Risk of injury and scalding!

- Let the engine cool down.
- Wear protective clothing, gloves, and goggles / safety mask.

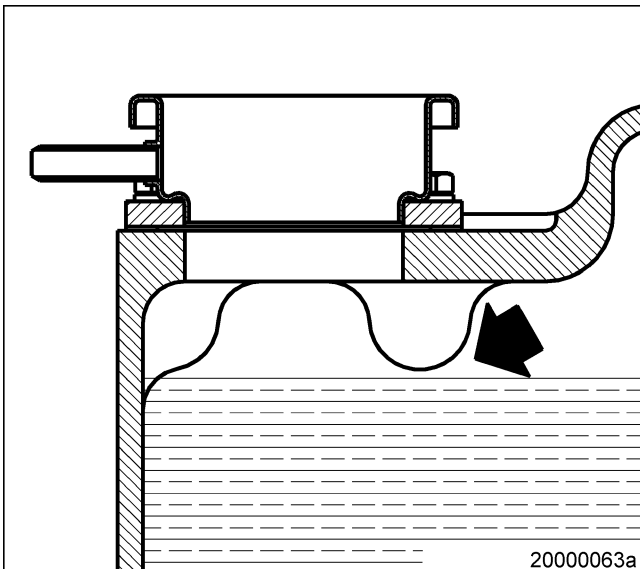

Coolant-level check at filler neck:

1. Turn breather valve of filler neck on coolant expansion tank counterclockwise to first stop and allow pressure to escape.
2. Continue to turn breather valve counterclockwise and remove.
3. Check coolant level (coolant must be visible at the lower edge of the cast-in eye).

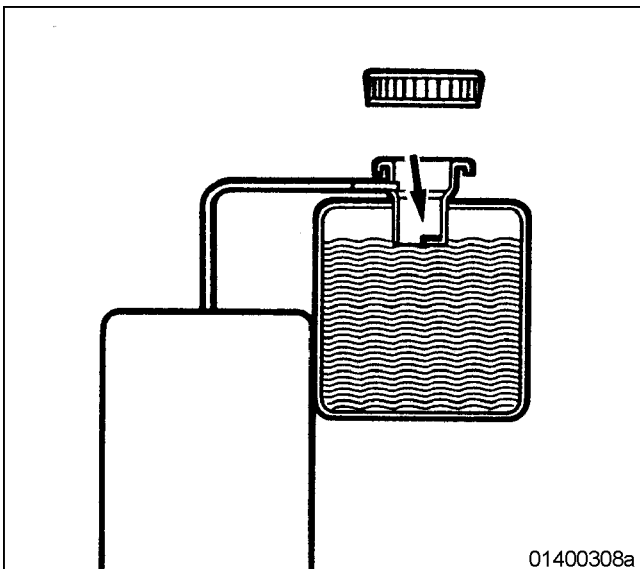

Coolant-level check at external cooler:

1. Check coolant level (coolant must be visible at marking plate).
2. If required, top up with treated engine coolant (→ Page 6 – 39).
3. Check proper condition of breather valve, clean sealing faces if required.
4. Set breather valve onto filler neck and close it.

Coolant-level check by means of level sensor:

1. Switch engine control system ON and check display (coolant level is automatically monitored by the engine control system).
2. If required, top up with treated engine coolant (→ Page 6 – 39).

6.14.5 Engine coolant – sample extraction and analysis

Preconditions

- MTU Fluids and Lubricants Specification (A001061/..) is available.

Special tools

Designation / Use	Part No.	Qty.
MTU test kit	→ TC	



Unguarded rotating and moving engine components.

Risk of serious injury – danger to life!

- Take special care when working on a running engine.



Coolant is hot and under pressure.

Risk of injury and scalding!

- Let the engine cool down.
- Wear protective clothing, gloves, and goggles / safety mask.



Engine noise above 85 dB (A).

Risk of damage to hearing!

- Wear ear protectors.

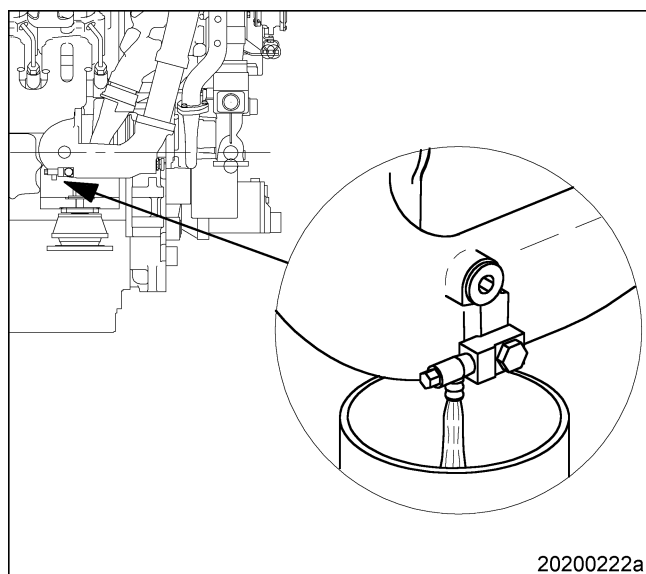

Engine coolant – sample extraction and analysis

1. With the engine running, open drain valve.
2. Flush sample-extraction point by draining approx. 1 liter coolant.
3. Drain approx. 1 liter coolant into a clean container.
4. Close drain valve.
5. Using the equipment and chemicals of the MTU test kit, examine coolant for:
 - antifreeze concentration;
 - corrosion inhibitor concentration;
 - pH value.
6. Change engine coolant according to the coolant operating times specified in the MTU Fluids and Lubricants Specification (→ Page 6 – 41).

6.14.6 HT cooling pump – relief bore check



Unguarded rotating and moving engine components.

Risk of serious injury – danger to life!

- Take special care when working on a running engine.



Engine noise above 85 dB (A).

Risk of damage to hearing!

- Wear ear protectors.

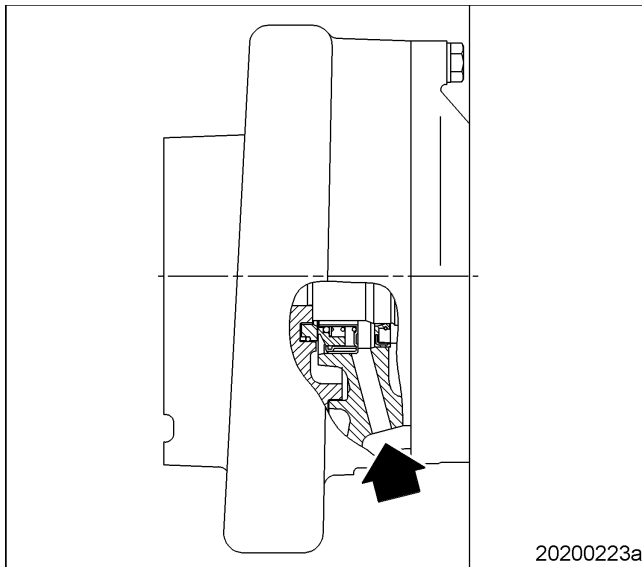
**HT cooling pump – relief bore check**

1. Check relief bore for oil and water discharge.
2. Stop engine (→ Page 3–5) and disable engine start.
3. Clean the relief bore with a wire if it is dirty.
 - Permissible water discharge: up to 10 drops per hour;
 - Permissible oil discharge: up to 5 drops per hour.
4. If discharge exceeds the specified limits: Contact Service.

6.15 Cooling System, LT Circuit

6.15.1 Charge-air coolant system filling

Preconditions

- Engine is stopped and starting disabled.
- MTU Fluids and Lubricants Specification (A001061/..) is available.

Material

Designation / Use	Part No.	Qty.
Coolant	→ FLS	

Spare parts

Designation / Use	Part No.	Qty.
Sealing ring	→ SPC	



Engine noise above 85 dB (A).
Risk of damage to hearing!
 • Wear ear protectors.



Cold coolant in hot engine can cause thermal stress.
Formation of cracks in components!
 • Fill / top up coolant only into cold engine.

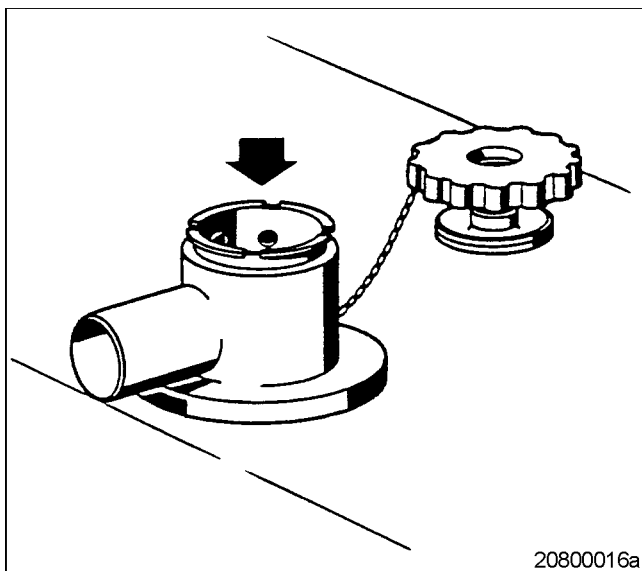

Preparatory steps

1. Turn breather valve of filler neck on coolant expansion tank counterclockwise to first stop and allow pressure to escape.
2. Continue to turn breather valve counterclockwise and remove.
3. Remove plug from filling point on coolant line to charge-air cooler.

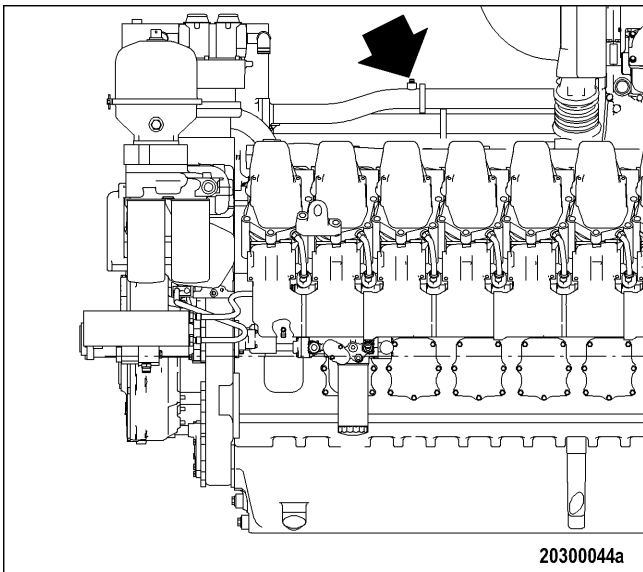

Charge-air coolant system filling

1. Pour treated coolant via the filling point on the coolant line to the intercooler and via the filler neck of the expansion tank until coolant is visible at the marking plate.
2. Install plugs with new sealing rings at the filling points.
3. Check proper condition of breather valve, clean sealing faces if required.
4. Set breather valve onto filler neck and close it.

Final steps

1. Start the engine and operate it at idle speed for some minutes.
2. Check coolant level (→ Page 6 – 48).

6.15.2 Charge-air coolant draining

Preconditions

- Engine is stopped and starting disabled.

Spare parts

Designation / Use	Part No.	Qty.
Sealing ring	→ SPC	

 WARNING	<p>Coolant is hot and under pressure.</p> <p>Risk of injury and scalding!</p> <ul style="list-style-type: none"> • Let the engine cool down. • Wear protective clothing, gloves, and goggles / safety mask.
---	--

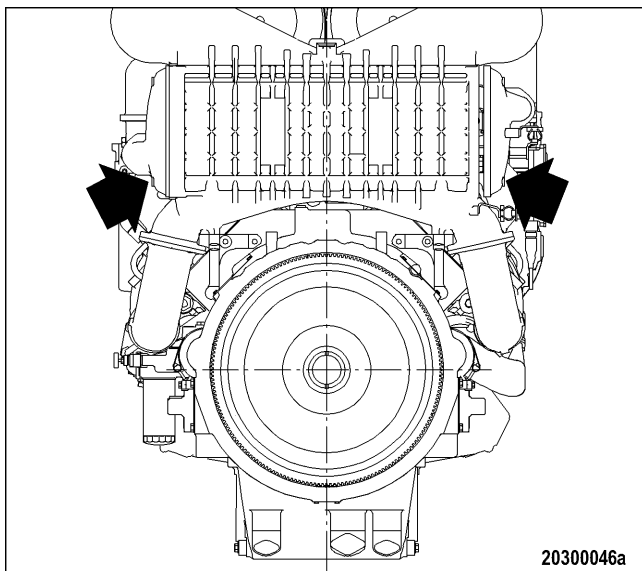
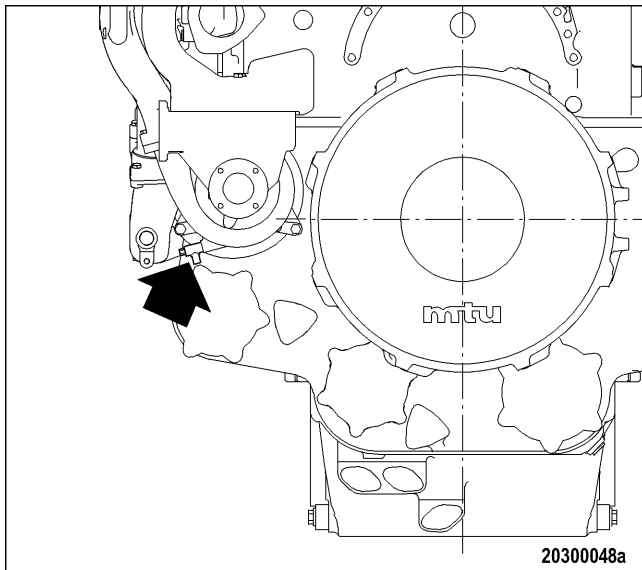

Charge-air coolant draining

1. Provide an appropriate container to drain the coolant into.
2. Turn breather valve of filler neck on coolant expansion tank counterclockwise to first stop and allow pressure to escape.
3. Continue to turn breather valve counterclockwise and remove.
4. Draw off precipitated corrosion inhibitor oil from the expansion tank through filler neck.
5. Open drain cocks and drain plugs and drain coolant at the following points:
 - at the LT cooling pump
6. Draining of residual coolant:
 - at intercooler, left and right side
7. Close all drain valves and install drain plugs with new sealing rings.
8. Set breather valve onto filler neck and close it.

6.15.3 Charge-air coolant change

Material

Designation / Use	Part No.	Qty.
Coolant	→ FLS	

Drain charge-air coolant system (→ Page 6 – 46).

Fill charge-air coolant system (→ Page 6 – 45).

6.15.4 Charge-air coolant level check

Preconditions

- Engine is stopped and starting disabled.
- MTU Fluids and Lubricants Specification (A001061/..) is available.

 WARNING	Coolant is hot and under pressure. Risk of injury and scalding! <ul style="list-style-type: none"> • Let the engine cool down. • Wear protective clothing, gloves, and goggles / safety mask.
---	---

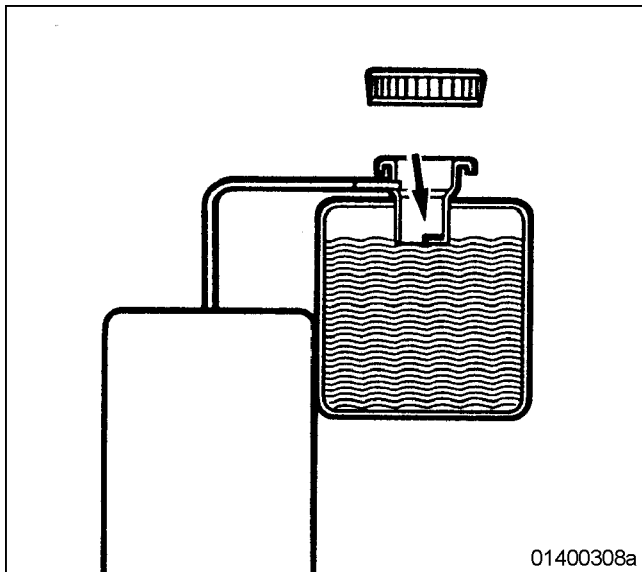

Charge-air coolant level check at filler neck:

1. Turn breather valve of filler neck on coolant expansion tank counterclockwise to first stop and allow pressure to escape.
2. Continue to turn breather valve counterclockwise and remove.
3. Check coolant level (coolant must be visible at marking plate).
4. If required, top up with treated coolant (→ Page 6 – 45).
5. Check proper condition of breather valve, clean sealing faces if required.
6. Set breather valve onto filler neck and close it.

Charge-air coolant level check by means of level sensor:

1. Switch engine control system ON and check display (coolant level is automatically monitored by the engine control system).
2. If required, top up with treated coolant (→ Page 6 – 45).

6.15.5 Charge-air coolant sample extraction and analysis

Preconditions

- MTU Fluids and Lubricants Specification (A001061/..) is available.

Special tools

Designation / Use	Part No.	Qty.
MTU test kit	→ TC	

 DANGER	Unguarded rotating and moving engine components. Risk of serious injury – danger to life! <ul style="list-style-type: none"> • Take special care when working on a running engine.
--	---

 WARNING	Coolant is hot and under pressure. Risk of injury and scalding! <ul style="list-style-type: none"> • Let the engine cool down. • Wear protective clothing, gloves, and goggles / safety mask.
---	---

 Engine noise above 85 dB (A).
Risk of damage to hearing!
 • Wear ear protectors.

WARNING

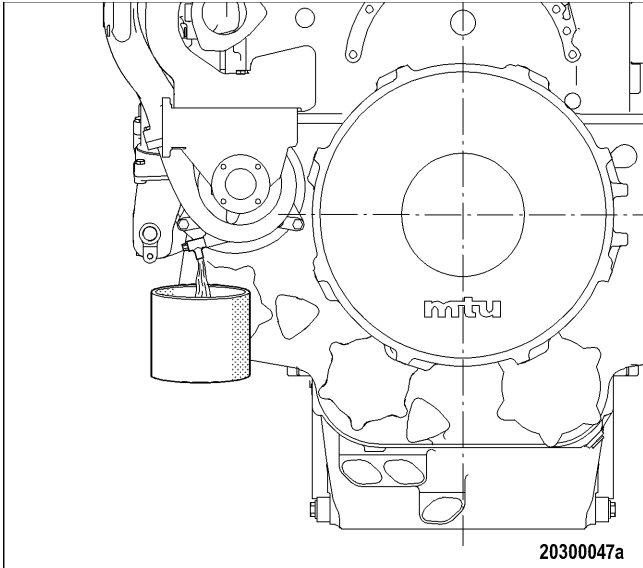

Charge-air coolant sample extraction and analysis

1. With the engine running, open drain valve.
2. Flush sample-extraction point by draining approx. 1 liter coolant.
3. Drain approx. 1 liter coolant into a clean container.
4. Close drain valve.
5. Using the equipment and chemicals of the MTU test kit, examine coolant for:
 - antifreeze concentration;
 - corrosion inhibitor concentration;
 - pH value.
6. Change charge-air coolant according to the coolant operating times specified in the MTU Fluids and Lubricants Specification (→ Page 6 – 47).

6.15.6 LT cooling pump – relief bore check

 Unguarded rotating and moving engine components.
Risk of serious injury – danger to life!
 • Take special care when working on a running engine.

DANGER

 Engine noise above 85 dB (A).
Risk of damage to hearing!
 • Wear ear protectors.

WARNING

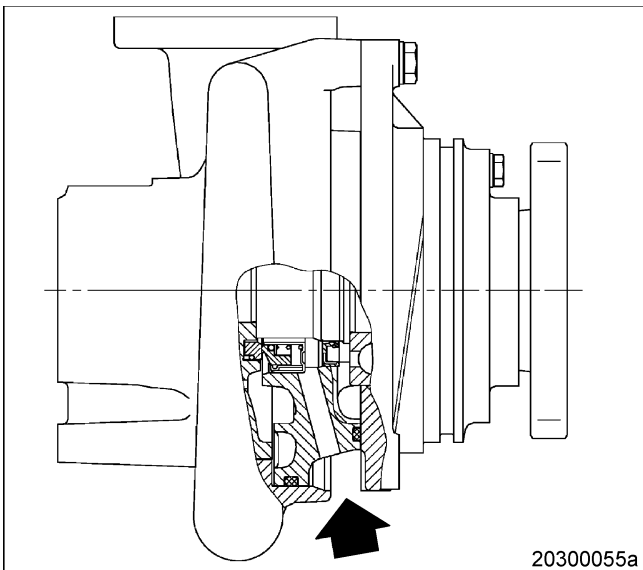

LT cooling pump – relief bore check

1. Check relief bore for oil and water discharge.
2. Stop engine (→ Page 3 – 5) and disable engine start.
3. Clean the relief bore with a wire if it is dirty.
 - Permissible water discharge: up to 10 drops per hour;
 - Permissible oil discharge: up to 5 drops per hour.
4. If discharge exceeds the specified limits: Contact Service.

6.16 Battery-Charging Generator

6.16.1 Battery-charging generator drive – drive belt condition check

Preconditions

- Engine is stopped and starting disabled.

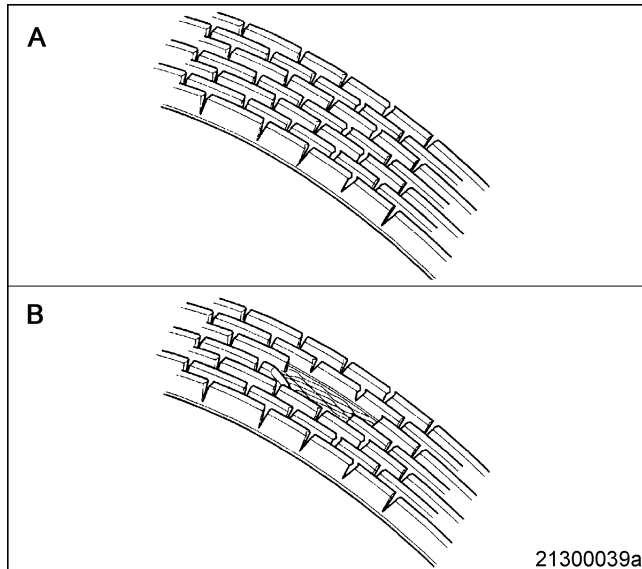

Belt condition check

1. Remove guard cover.
2. Check belt for contamination by oil, cracks, wear, and signs of overheating.
3. Replace drive belt:
 - If belt is oily;
 - If belt shows signs of overheating;
 - If ribs are broken around the entire circumference (A);
 - If ribs are broken around the entire circumference and material is broken off in some places (B) (→ Page 6 – 51).
4. Install guard cover.

6.16.2 Battery-charging generator drive – drive-belt tension check and adjustment

Preconditions

- Engine is stopped and starting disabled.

Special tools

Designation / Use	Part No.	Qty.
Belt-tension tester	→ TC	

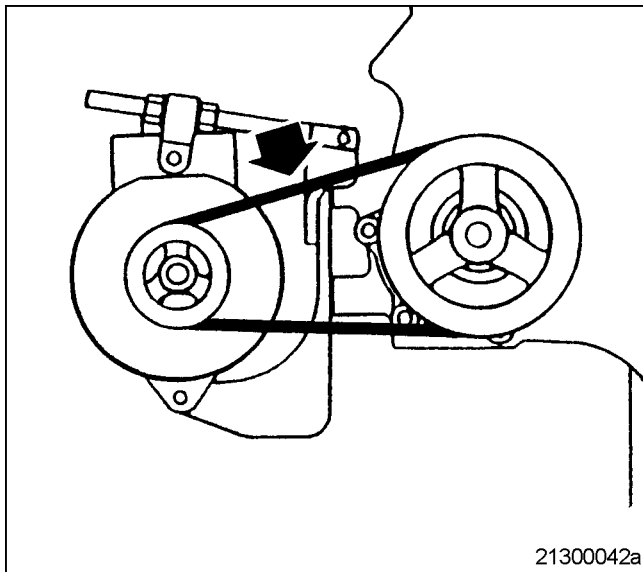

Belt tension check

1. Remove guard cover.
2. Place belt-tension tester onto drive belt midway between the belt pulleys.
3. Press button uniformly down onto drive-belt surface until spring disengagement can be heard and felt.
4. Do not press any further, otherwise the reading is not exact.
5. Take off belt-tension tester without changing the position of the indication arm.
6. Read off measuring value at the intersection of indication arm and "KG" scale.
7. If the measured value deviates from the specified belt tension (57 kg to 70 kg), readjust belt tension.

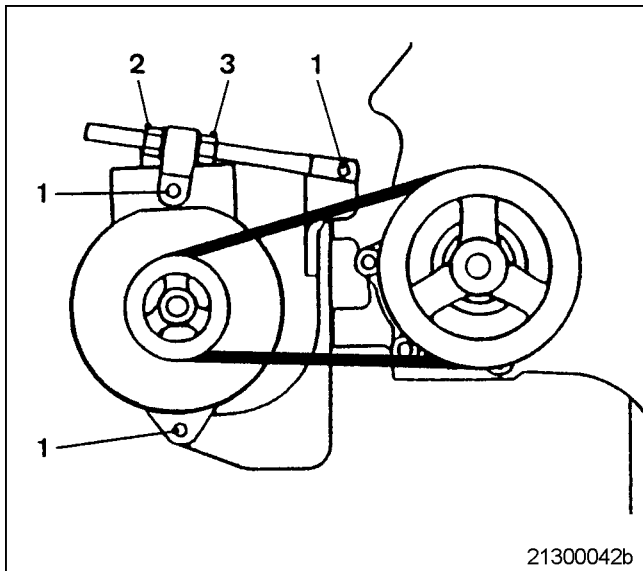

Belt tension adjustment

1. Loosen locknut (2) and screws (1).
2. Tension drive belt with tensioning nut (3) and check belt tension.
3. Tighten locknut (2).
4. Tighten screws (1).
5. Install guard cover.

6.16.3 Battery-charging generator drive – drive belt replacement

Preconditions

- Engine is stopped and starting disabled.

Spare parts

Designation / Use	Part No.	Qty.
Vee belt	→ SPC	

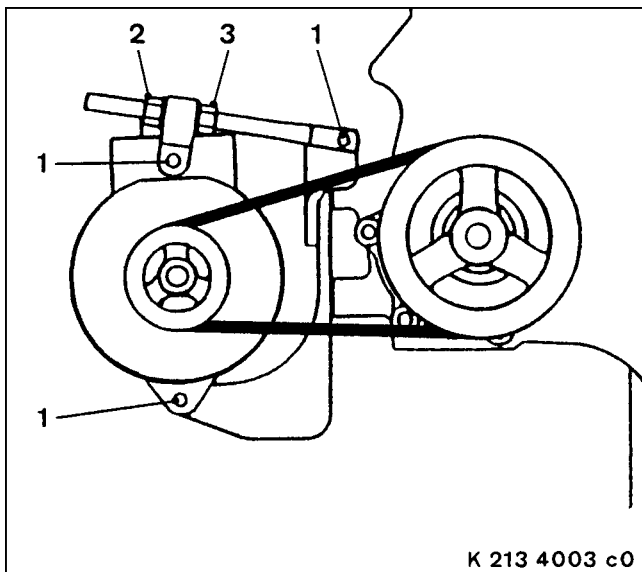

Battery-charging generator drive – drive belt replacement

1. Remove guard cover.
2. Loosen locknut (2) and screws (1).
3. Release drive belt with tensioning nut (3) and take off belt.
4. Check belt pulleys for cleanliness, remove dirt, if any.
5. Fit new drive belt.
6. Tension drive belt with tensioning nut (3) and check belt tension (→ Page 6 – 50).
7. Tighten locknut (2).
8. Tighten screws (1).
9. Install guard cover.
10. Check drive-belt tension after 30 minutes and again after 8 hours engine run time.

6.16.4 Battery-charging generator – condition check

Preconditions

- Engine is stopped and starting disabled.

Battery-charging generator – condition check

1. Check securing screws of battery-charging generator for secure seating.
2. Tighten loose screw connections.
3. Check wiring (→ Page 6 – 55).

6.17 Engine Mounts

6.17.1 Engine/generator mounting security check

Preconditions

- Engine is stopped and starting disabled.

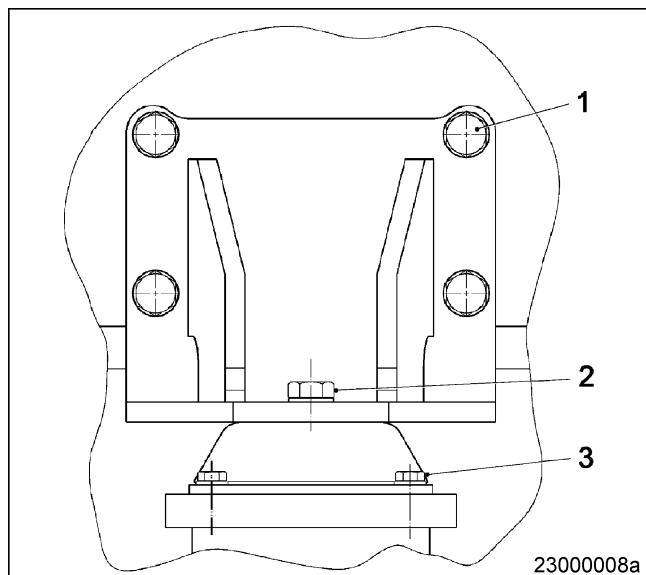

Engine/generator mounting security check

1. Check securing screws (1), (2) and (3) of engine mounting for secure seating.
2. Check securing screws (2) and (3) of generator mounting for secure seating.
3. Tighten loose screw connections.

6.17.2 Engine/generator mounting – resilient elements check

Preconditions

- Engine is stopped and starting disabled.
- Engine is filled with coolant and engine oil.

Special tools

Designation / Use	Part No.	Qty.
Feeler gauge	→ TC	
Vernier caliper	→ TC	

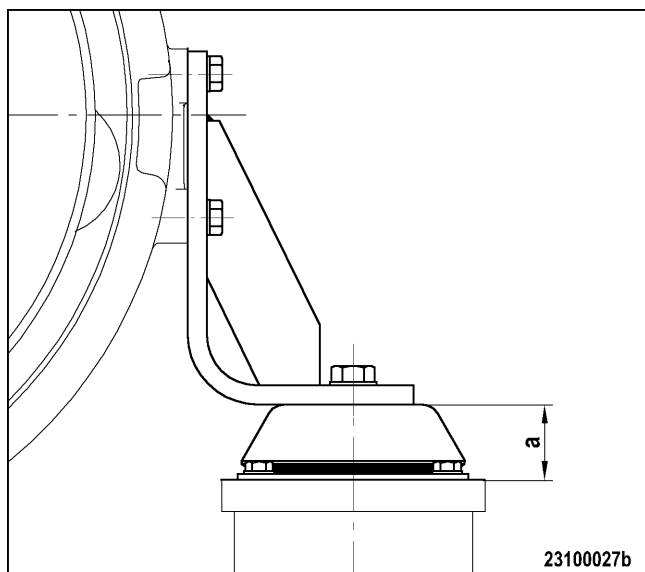
**Engine/generator mounting – resilient elements check**

1. Wipe rubber surface with dry cloth, do not use organic detergents.
2. Check resilient elements for crack formation and deformation by visual inspection.
3. Have cracked elements replaced, contact Service.

Setting dimension check

1. Measure dimension (a) with Vernier caliper.
2. If dimension (a) is less than 57 mm, resilient elements must be replaced. Contact Service.

6.18 General Wiring, Engine / Gearbox / Plant

6.18.1 Engine wiring check

Preconditions

- Engine is stopped and starting disabled.

Material

Designation / Use	Part No.	Qty.
Isopropyl alcohol	→ FLS	

Engine wiring check

1. Check securing screws of cable clamps on the engine and tighten loose screw connections.
2. Make certain that cables are securely seated in clamps and cannot move freely.
3. Check cable binders for secure seating, tighten loose cable binders.
4. Replace defective cable binders.
5. Inspect electrical components visually for damage:
 - connector housings;
 - contacts;
 - connector sockets;
 - cables and terminals;
 - plug-in contacts.
6. If conductors are damaged, contact Service.
7. Clean dirty connector housings, sockets and contacts with isopropyl alcohol.

6.19 Engine Governor (Electronic) / Control System

6.19.1 ECU and connectors cleaning

Preconditions

- Engine is stopped and starting disabled.

Special tools

Designation / Use	Part No.	Qty.
Connector pliers	→ TC	

Material

Designation / Use	Part No.	Qty.
Isopropyl alcohol	→ FLS	

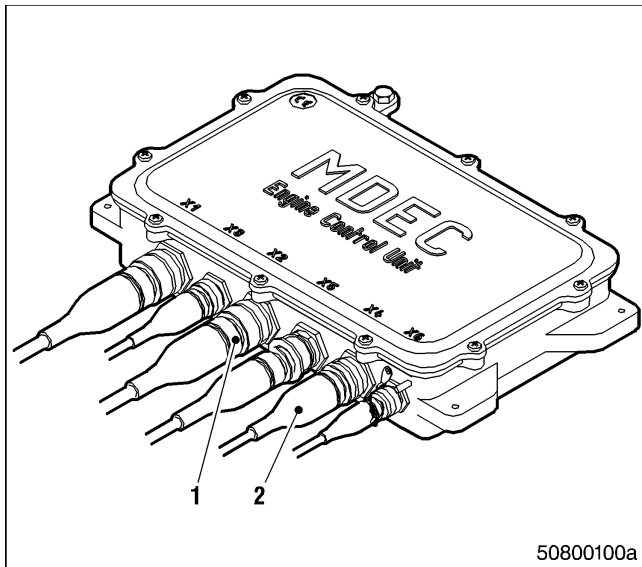

ECU and connectors cleaning

1. Remove coarse dirt from housing surface using a cloth moistened with isopropyl alcohol.
2. Remove dirt from surface of connectors (1), connector sockets and shrink sleeves (2) using a cloth moistened with isopropyl alcohol.
3. Check legibility of cable labels. Clean or replace illegible labels.

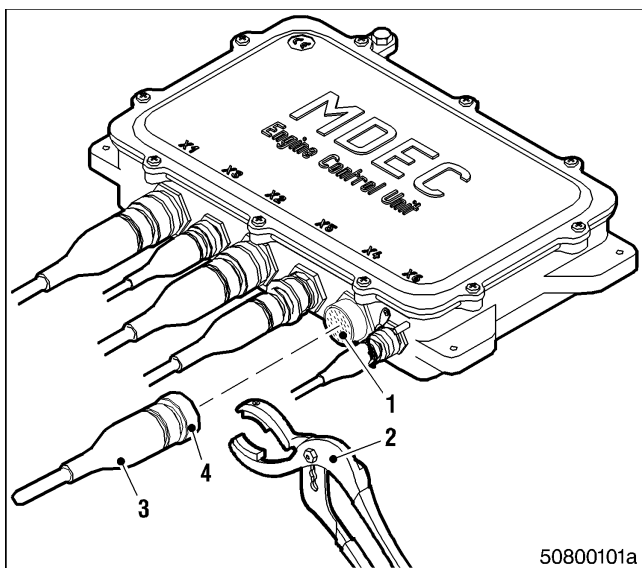

Cleaning severely contaminated connectors on ECU

1. Use connector pliers (2) to disengage bayonet union nut (4) and withdraw connector (3).
2. Clean connector housings, connector socket housings (1) and all contacts with isopropyl alcohol.
3. When connectors, sockets and all contacts are dry: Install connectors and check plug-in connection on ECU (→ Page 6 – 57).

6.19.2 ECU – checking plug-in connections

Preconditions

- Engine is stopped and starting disabled.

Special tools

Designation / Use	Part No.	Qty.
Connector pliers	→ TC	

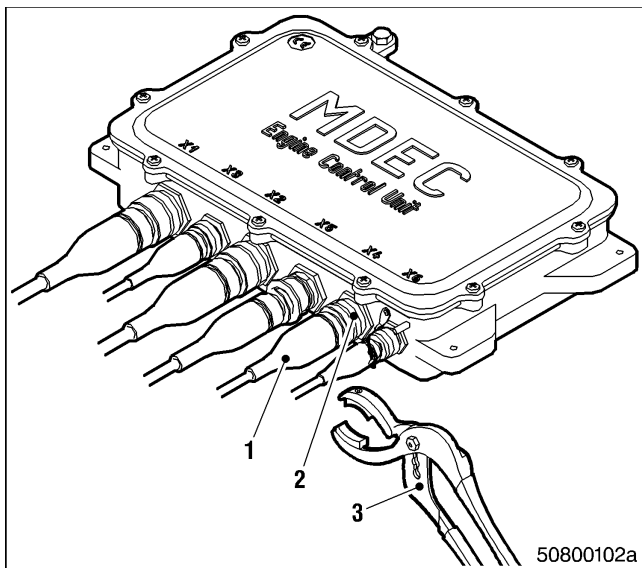

ECU – checking plug-in connections

1. Use connector pliers (3) to make certain that all plug-in connections of ECU are securely seated.
2. Tighten loose bayonet union nuts (2) with connector pliers (3) by turning them clockwise until they lock into place.
3. Ensure that unassigned connector sockets are protected with covering caps.

7 Annex

7.1 Abkürzungsverzeichnis	7-1
7.2 Index	7-3

7.1 Abbreviations

Abbreviation	Meaning	Explanation
A/D	Analog-to-Digital	
AL	Alarm	Alarm (general)
ANSI	American National Standards Institute	
ATL	Abgasturbolader	Turbocharger
BR	Baureihe	Engine Series
CAN	Controller Area Network	
DIN	Deutsches Institut für Normung e. V.	German Standardization Organization, at the same time identifier of German standards (DIN = "Deutsche Industrie-Norm")
DL	Default Lost	Alarm: Default CAN bus failure
ECU	Engine Control Unit	
EDM	Engine Data Module	
EEPROM	Electrically Erasable and Programmable Read-Only Memory	
EMU	Engine Monitoring Unit	
FLS	Fluids and Lubricants Specification	MTU Publication No. A01061/..
HI	High	Alarm: Measured value exceeds 1st maximum limit
HIHI	High High	Alarm: Measured value exceeds 2nd maximum limit
HT	High Temperature	
IDM	Interface Data Module	
IMO	International Maritime Organisation	
ISO	International Organization for Standardization	
KGS	Kraftgegenseite	Engine free end in accordance with DIN ISO 1204
KS	Kraftseite	Engine driving end in accordance with DIN ISO 1204
LED	Light Emitting Diode	
LO	Low	Alarm: Measured value lower than 1st minimum limit
LOLO	Low Low	Alarm: Measured value lower than 2nd minimum limit
OT	Oberer Totpunkt	Top dead center (TDC)
P-xyz	Pressure-xyz	Pressure measuring point xyz
PAN	Panel	
PC	Personal Computer	
PIM	Peripheral Interface Module	

Abbrevia- tion	Meaning	Explanation
RL	Redundancy Lost	Alarm: Redundant CAN bus failure
SAE	Society of Automotive Engineers	U.S. standardization organization
SD	Sensor Defect	Alarm: Sensor failure
SS	Safety System	Alarm initiated by safety system
SPC	Spare Parts Catalog	
T-xyz	Temperature-xyz	Temperature measuring point xyz
TC	Tools Catalog	
TD	Transmitter Deviation	
UT	Unterer Totpunkt	Bottom dead center (BDC)

7.2 Index

A

Abkürzungsverzeichnis	7 – 1
After stopping the engine – engine remains ready for operation	3 – 6
After stopping the engine – putting the engine out of service	3 – 6
Air Filter	6 – 30
Air filter removal and installation	6 – 30
Air filter replacement	6 – 30
Air filter removal and installation	6 – 30
Air filter replacement	6 – 30
Air Intake	6 – 31
Service indicator – signal ring position check	6 – 31
Air starter – manual operation	6 – 32

B

Battery-Charging Generator	6 – 50
Battery-charging generator – condition check	6 – 52
Battery-charging generator drive – drive belt condition check	6 – 50
Battery-charging generator drive – drive belt replacement	6 – 51
Battery-charging generator drive – drive-belt tension check and adjustment	6 – 50
Battery-charging generator – condition check	6 – 52
Battery-charging generator drive – drive belt condition check	6 – 50
Battery-charging generator drive – drive belt replacement	6 – 51
Battery-charging generator drive – drive-belt tension check and adjustment	6 – 50

C

Centrifugal oil filter – cleaning and filter-sleeve replacement	6 – 37
Charge-air coolant change	6 – 47
Charge-air coolant draining	6 – 46
Charge-air coolant level check	6 – 48
Charge-air coolant sample extraction and analysis	6 – 48
Charge-air coolant system filling	6 – 45
Charge-Air Cooling, General, Left Side	6 – 29
Intercooler – checking condensate drains for coolant discharge and obstruction	6 – 29
Cooling System, General, HT Circuit	6 – 39

Engine coolant – sample extraction and analysis	6 – 43
Engine coolant change	6 – 41
Engine coolant draining	6 – 40
Engine coolant system filling	6 – 39
Engine coolant-level check	6 – 42
HT cooling pump – relief bore check	6 – 43
Cooling System, LT Circuit	6 – 45
Charge-air coolant change	6 – 47
Charge-air coolant draining	6 – 46
Charge-air coolant level check	6 – 48
Charge-air coolant sample extraction and analysis	6 – 48
Charge-air coolant system filling	6 – 45
LT cooling pump – relief bore check	6 – 49
Crankcase Breather	6 – 7
Crankcase breather – oil separator replacement and diaphragm check	6 – 7
Crankcase breather – oil separator replacement and diaphragm check	6 – 7
Cylinder Liner	6 – 3
Cylinder-liner endoscopic examination	6 – 3
Instructions and comments on endoscopic and visual examination of cylinder liner	6 – 5
Cylinder-head cover removal and installation	6 – 13
Cylinder-liner endoscopic examination	6 – 3

E

ECU – checking plug-in connections	6 – 57
ECU alarms	5 – 4
ECU and connectors cleaning	6 – 56
Emergency start (override mode)	3 – 3
Emergency stop	3 – 5
Engine	6 – 1
Engine – barring manually	6 – 1
Engine – barring with starting system	6 – 1
Engine test run	6 – 2
Engine – barring manually	6 – 1
Engine – barring with starting system	6 – 1
Engine coolant – sample extraction and analysis	6 – 43
Engine coolant change	6 – 41
Engine coolant draining	6 – 40
Engine coolant system filling	6 – 39
Engine coolant-level check	6 – 42
Engine Governor (Electronic) / Control System	6 – 56

ECU – checking plug-in connections	6 – 57
ECU and connectors cleaning	6 – 56
Engine layout	2 – 1
Engine Layout	2 – 1
Engine layout	2 – 1
Engine Mounts	6 – 53
Engine/generator mounting – resilient elements check	6 – 53
Engine/generator mounting security check	6 – 53
Engine oil change	6 – 34
Engine oil filter replacement	6 – 36
Engine oil level check	6 – 35
Engine test run	6 – 2
Engine wiring check	6 – 55
Engine/generator mounting – resilient elements check	6 – 53
Engine/generator mounting security check	6 – 53
Engine-oil sample extraction and analysis	6 – 33

F

Fuel Filter	6 – 22
Fuel filter replacement	6 – 22
Fuel prefilter – differential pressure check and adjustment of gauge	6 – 23
Fuel prefilter – draining	6 – 24
Fuel prefilter – filter element replacement	6 – 27
Fuel prefilter – flushing	6 – 25
Fuel prefilter cleaning	6 – 23
Fuel filter replacement	6 – 22
Fuel Injector	6 – 15
Injector removal and installation	6 – 15
Injector replacement	6 – 15
Fuel prefilter – differential pressure check and adjustment of gauge	6 – 23
Fuel prefilter – draining	6 – 24
Fuel prefilter – filter element replacement	6 – 27
Fuel prefilter – flushing	6 – 25
Fuel prefilter cleaning	6 – 23
Fuel system	6 – 21
Fuel system venting	6 – 21
Fuel system venting	6 – 21

G

General Wiring, Engine / Gearbox / Plant	6 – 55
Engine wiring check	6 – 55

H

HT cooling pump – relief bore check	6 – 43
-------------------------------------	--------

I

Index	7 – 3
Injector removal and installation	6 – 15
Injector replacement	6 – 15
Instructions and comments on endoscopic and visual examination of cylinder liner	6 – 5
Intercooler – checking condensate drains for coolant discharge and obstruction	6 – 29

L

LT cooling pump – relief bore check	6 – 49
Lube Oil System	6 – 33
Engine oil change	6 – 34
Engine oil level check	6 – 35
Engine-oil sample extraction and analysis	6 – 33

M

Maintenance and servicing	4 – 1
Maintenance and Servicing	4 – 1
Maintenance and servicing	4 – 1
Maintenance schedule	4 – 2, 4 – 4, 4 – 6
Maintenance Schedule – Application Group 3A	4 – 6
Maintenance schedule	4 – 6
Maintenance Schedule – Application Group 3B	4 – 4
Maintenance schedule	4 – 4
Maintenance Schedule – Application Groups 3C and 3D	4 – 2
Maintenance schedule	4 – 2

O

Oil Filtration / Cooling	6 – 36
Centrifugal oil filter – cleaning and filter-sleeve replacement	6 – 37
Engine oil filter replacement	6 – 36
Operational checks	3 – 4

P

Putting the engine into operation after extended out-of-service periods (>3 months)	3 – 1
Putting the engine into operation after scheduled out-of-service-period	3 – 2

S

Safety, accident prevention and environmental protection instructions	1 – 1
Service indicator – signal ring position check	6 – 31
Starter condition check	6 – 32

Starting System	6 – 32
Air starter – manual operation	6 – 32
Starter condition check	6 – 32
Starting the engine in manual mode	3 – 2
Stopping the engine in manual mode	3 – 5

T

Technical Data	2 – 2
Technical Data	2 – 2
Troubleshooting	5 – 1

V

Valve clearance check and adjustment	6 – 9
Valve Gear	6 – 9
Cylinder-head cover removal and installation	6 – 13
Valve clearance check and adjustment	6 – 9
Valve gear lubrication	6 – 9
Valve gear lubrication	6 – 9

