

MTU_ValueService **Technical Documentation**

Diesel Engine
12 V 4000 G23, G43
12 V 4000 G63, G83
16 V 4000 G23, G43
16 V 4000 G63, G83

Operating Instructions
M015710/01E



Printed in Germany

© 2007 Copyright MTU Friedrichshafen GmbH

This Publication is protected by copyright and may not be used in any way whether in whole or in part without the prior written permission of MTU Friedrichshafen GmbH. This restriction also applies to copyright, distribution, translation, microfilming and storage or processing on electronic systems including data bases and online services. This handbook is provided for use by maintenance and operating personnel in order to avoid malfunctions or damage during operation.

Subject to alterations and amendments.

Wichtig – Important – Importante

Bitte die Karte „Inbetriebnahmemeldung“ abtrennen und ausgefüllt an MTU Friedrichshafen GmbH zurücksenden.

Die Informationen der Inbetriebnahmemeldung sind Grundlage für den vertraglich vereinbarten Logistik-Support (Gewährleistung, Ersatzteile etc.).

Please complete and return the “Commissioning Note” card below to MTU Friedrichshafen GmbH.

The Commissioning Note information serves as a basis for the contractually agreed logistic support (warranty, spare parts, etc.).

Veillez séparer la carte “Signalisation de mise en service“ et la renvoyer à la MTU Friedrichshafen GmbH.

Les informations contenues dans la signalisation de mise en service constituent la base pour l'assistance en exploitation contractuelle (garantie, rechanges, etc.).

Rogamos separen la tarjeta “Aviso de puesta en servicio“ y la devuelvan rellena a MTU Friedrichshafen GmbH.

Las informaciones respecto al aviso de puesta en servicio constituyen la base para el soporte logístico contractual (garantía, piezas de repuesto, etc.).

Ritagliare “Avviso di messa in servizio“ e rispedirlo debitamente compilato alla MTU Friedrichshafen GmbH.

Le informazioni ivi registrate sono la base per il supporto logistico contrattuale (garanzia, ricambi, ecc.).

É gentileza cortar o cartão "Participação da colocação em serviço", preenchê-lo e devolvê-lo a MTU Friedrichshafen.

Os dados referentes à colocação em serviço representam a base para o suporte logístico (garantia, peças sobressalentes, etc.) estabelecido contratualmente.



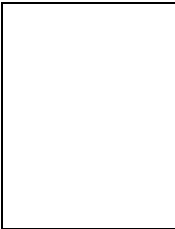

Postcard

MTU Friedrichshafen GmbH
Department MST
88040 Friedrichshafen
GERMANY

Bitte in Blockschrift ausfüllen!
Please use block capitals!
Prière de remplir en lettres capitales!
¡A rellenar en letras de imprenta!
Scrivere in stampatello!
Favor preencher com letras de forma!



Motornr.: Engine No.: N° du moteur: N° de motor: Motore N.: No. do motor:
--

Auftragsnr.: MTU works order No.: N° de commande: N° de pedido: N. commessa: No. do pedido:
--

**Inbetriebnahme-
meldung**

**Commissioning
Note**

Motortyp: Engine model: Type du moteur: Tipo de motor: Motore tipo: Tipo do motor:

Inbetriebnahmedatum: Date put into operation: Mise en service le: Fecha de puesta en servicio: Messa in servizio il: Data da colocação em serviço:

**Notice de mise
en service**

**Aviso de puesta
en servicio**

Eingebaut in: Installation site: Lieu de montage: Lugar de montaje: Installato: Incorporado em:
--

Schiffstyp / Schiffshersteller: Vessel/type/class / Shipyard: Type du bateau / Constructeur: Tipo de buque / Constructor: Tipo di barca / Costruttore Tipo de embarcação/estaleiro naval:
--

**Avviso di messa
in servizio**

Endabnehmer/Anschrift: End user's address: Adresse du client final: Dirección del cliente final: Indirizzo del cliente finale: Usuário final/endereço:

**Participação da
colocação em
serviço**

Bemerkung: Remarks: Remarques: Observaciones: Commento: Observações:

1	Safety	05
1.1	General conditions	05
1.2	Personnel and organizational requirements	06
1.3	Transport	07
1.4	Safety requirements when working on the engine	08
1.5	Auxiliary materials, fire prevention and environmental protection	11
1.6	Standards for warning notices in the publication	13
2	Product Summary	15
2.1	Engine Layout	15
2.1.1	Engine layout	15
2.2	Engine Side and Cylinder Designations	17
2.2.1	Engine side and cylinder designations	17
2.3	Main Engine Dimensions	18
2.3.1	Engine – Main dimensions	18
2.4	Firing Order	19
2.4.1	Firing order	19
2.5	Final Compression Pressure	20
2.5.1	Final compression pressure	20
2.6	Technical Data	21
2.6.1	12V 4000 Gx3 engine data: Standby operation 3D, optimized fuel consumption	21
2.6.2	16V 4000 Gx3 engine data: Standby operation 3D, optimized fuel consumption	26
2.6.3	Engine data 12/16V 4000 Gx3: Standby operation 3D, optimized exhaust emissions (EPA stage 2)	31
2.6.4	12V 4000 Gx3 engine data: Continuous operation, variable 3B, optimized fuel consumption	36
2.6.5	16V 4000 Gx3 engine data: Continuous operation, variable 3B, optimized fuel consumption	41
2.6.6	12/16 V 4000 Gx3 engine data: Continuous operation, variable 3B, optimized exhaust emission (EPA stage 2)	46
2.6.7	12V 4000 Gx3 engine data: Continuous operation, variable 3B, optimized exhaust emissions (TA-Luft)	51
3	Operation	55
3.1	Putting the engine into operation after extended out-of-service-periods (>3 months)	55
3.2	Putting the engine into operation after scheduled out-of-service-period	56
3.3	Starting the engine in manual mode	57
3.4	Emergency start (override mode)	58
3.5	Operational checks	59
3.6	Stopping the engine in manual mode	60

3.7	Emergency stop	61
3.8	After stopping the engine – engine remains ready for operation	62
3.9	After stopping the engine – putting the engine out of service	63
4	Maintenance	65
4.1	Preface	65
4.2	Maintenance schedule matrix	66
4.3	Maintenance tasks	68
5	Troubleshooting	71
5.1	Troubleshooting	71
5.2	Engine governor ADEC (ECU 7) for Series 4000 genset engines - Fault messages	74
6	Task Description	95
6.1	Engine	95
6.1.1	Engine – Barring manually	95
6.1.2	Engine – Barring with starting system	96
6.1.3	Engine test run	97
6.2	Cylinder Liner	98
6.2.1	Cylinder liner – Endoscopic examination	98
6.2.2	Instructions and comments on endoscopic and visual examination of cylinder liners	100
6.3	Crankcase Breather	102
6.3.1	Crankcase breather – Oil separator replacement, diaphragm check and replacement	102
6.4	Valve Drive	104
6.4.1	Valve gear – Lubrication	104
6.4.2	Valve clearance – Check and adjustment	105
6.4.3	Cylinder head cover – Remove and install	108
6.5	Injector	109
6.5.1	Injector – Replacement	109
6.5.2	Injector – Removal and Installation	110
6.6	Fuel System	114
6.6.1	Fuel system – Venting	114
6.7	Fuel Filter	115
6.7.1	Fuel filter – Replacement	115
6.7.2	Fuel prefilter cleaning	116
6.7.3	Fuel prefilter – differential pressure check and adjustment of gauge	117
6.7.4	Fuel prefilter – draining	118
6.7.5	Fuel prefilter – flushing	120
6.7.6	Fuel prefilter – filter element replacement	122
6.8	Charge-air Cooling, General, Left Side	124
6.8.1	Intercooler – Checking condensate drains for coolant discharge and obstructions	124
6.9	Air Filter	125

6.9.1	Air filter replacement	125
6.9.2	Air filter – Check	126
6.9.3	Air filter removal and installation	127
6.9.4	Rubber sleeves between air intake elbow and turbocharger – Replacement	128
6.10	Air Intake	129
6.10.1	Service indicator – Signal ring position check	129
6.11	Starting Equipment	130
6.11.1	Air starter – manual operation	130
6.11.2	Starter – Condition check	131
6.12	Lube-oil System, Lube-oil Circuit	132
6.12.1	Engine oil – Change	132
6.12.2	Engine oil – Level check	134
6.12.3	Engine oil – Sample extraction and analysis	135
6.13	Oil Filtration/Cooling	136
6.13.1	Engine oil filter – Replacement	136
6.13.2	Centrifugal oil filter – Cleaning and filter-sleeve replacement	137
6.14	Cooling Circuit, General, HT Circuit	139
6.14.1	Engine coolant – Change	139
6.14.2	Engine coolant – Filling	140
6.14.3	Engine coolant – Draining	142
6.14.4	Engine coolant level – Check	143
6.14.5	Engine coolant pump – Relief bore check	144
6.14.6	Engine coolant – Sample extraction and analysis	145
6.15	LT Circuit	146
6.15.1	Charge-air coolant change	146
6.15.2	Charge-air coolant – Filling	147
6.15.3	Charge-air coolant – Draining	149
6.15.4	Charge-air coolant level check	150
6.15.5	Charge-air coolant pump – Relief bore check	151
6.16	Belt Drive	152
6.16.1	Drive belt – Condition check	152
6.17	Battery-charging Generator	153
6.17.1	Battery-charging generator drive – Drive belt tension adjustment	153
6.17.2	Battery-charging generator drive – Drive belt replacement	154
6.18	Cabling, General for Engine / Gearbox / Plant	155
6.18.1	Engine wiring – Check	155
6.19	Accessories for Engine Governor (Electronic) / Control System	156
6.19.1	ECU and connectors – Cleaning	156
6.19.2	ECU – Checking plug-in connections	157
7	Special Tools	159
7.1	Special tools	159
8	Annex	167
8.1	Manufacturer’s documentation	167

8.2	MTU contact person/service partner	168
8.3	Abbreviations	169
8.4	Index	173

1 Safety

1.1 General conditions

General

In addition to the instructions in this publication, the applicable country-specific legislation and other compulsory regulations regarding accident prevention must be observed. This engine is a state-of-the art product and conforms with all applicable specifications and regulations. Nevertheless, persons and property may be at risk in the event of:

- Incorrect use
- Operation, maintenance and repair by unqualified personnel
- Modifications or conversions
- Non-compliance with the Safety Instructions

Correct use

The engine is intended exclusively for the application specified in the contract or defined at the time of delivery. Any other use is considered improper use. The manufacturer will accept no liability for any resultant damage. The responsibility is borne by the user alone.

Correct use also includes observation of and compliance with the maintenance specifications.

Modifications or Conversions

Modifications made by the customer to the engine may affect safety.

MTU will accept no liability or warranty claims for any damage caused by unauthorized modifications or conversions.

Spare parts

Only genuine MTU spare parts must be used to replace components or assemblies. In the event of any damage caused by the use of other spare parts, no liability nor warranty claims vis-à-vis the engine manufacturer will be accepted.

1.2 Personnel and organizational requirements

Personnel

Work on the engine must only be carried out by properly qualified and instructed personnel.

The specified legal minimum age must be observed.

Responsibilities of the operating, maintenance and repair personnel must be specified.

Organization

This publication must be issued to all personnel involved in operation, maintenance, repair or transportation.

It must be kept at hand near the engine and accessible at any time to all personnel involved in operation, maintenance, repair or transportation.

The personnel must be instructed on engine operation and repair by means of this publication, and in particular the safety instructions must be explained.

This is especially important for personnel who work on the engine only on an occasional basis. Such personnel must be given instructions repeatedly.

Working clothes and protective equipment

Wear proper work clothing for all work.

Depending on the kind of work, use additional protective equipment, e.g. protective goggles, gloves, helmet, apron.

Work clothing must be tight fitting so that it does not catch on rotating or projecting components.

Do not wear jewelry (e.g. rings, chains etc.).

1.3 Transport

Engine transport

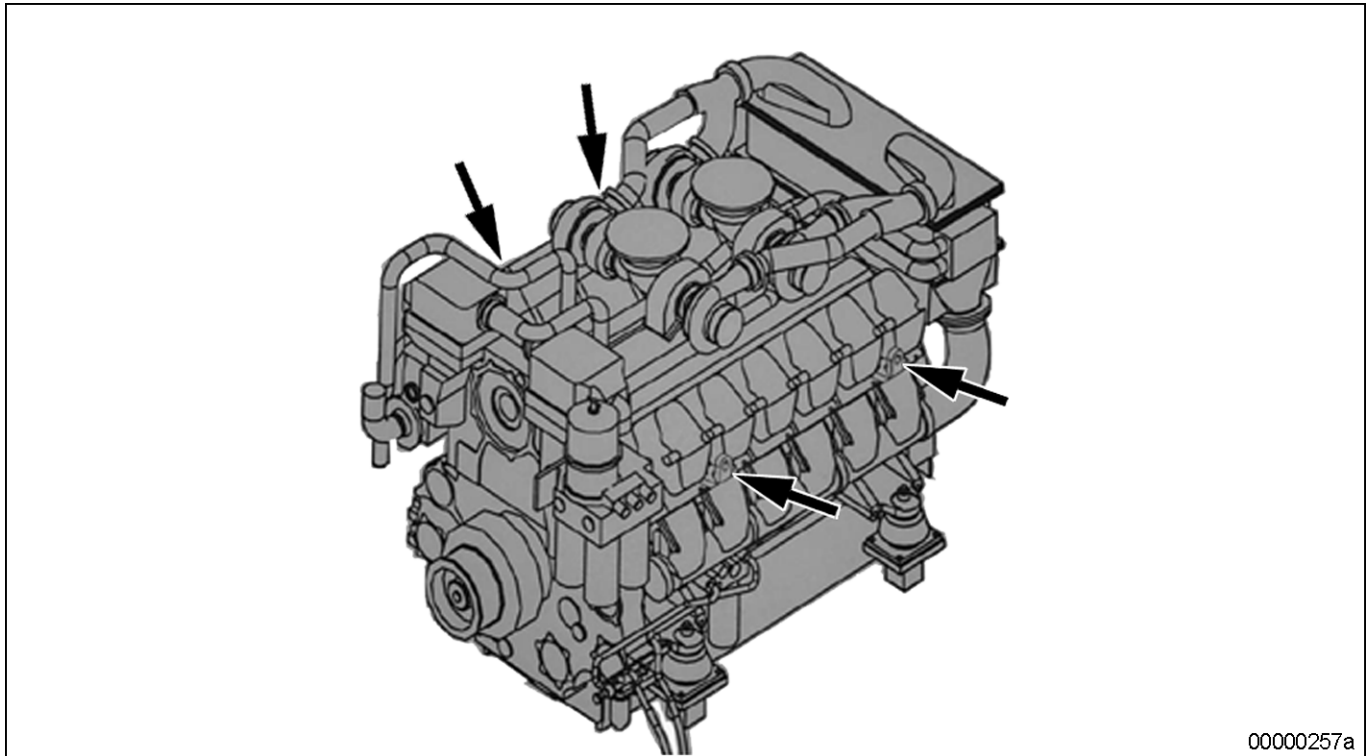

Lift the engine only with the lifting eyes provided.

Use only the transport and lifting equipment approved by MTU.

Take note of the engine center of gravity.

In the case of special packaging with aluminum foil, suspend the engine on the lifting eyes of the transport pallet or transport with equipment for heavy loads (forklift truck).

Prior to transporting the engine, it is imperative to install transportation locking devices for crankshaft and engine mounts.

Secure the engine against tilting during transportation. The engine must be especially secured against slipping or tilting when going up or down inclines and ramps.

Setting the engine down after transport

Place the engine only on an even, firm surface.

Ensure appropriate consistency and load-bearing capacity of the ground or support surface.

Never place an engine on the oil pan, unless expressly authorized by MTU on a case-to-case basis to do so.

1.4 Safety requirements when working on the engine

Safety precautions when putting the equipment into operation

Prior to initial operation, the product must have been installed correctly and approved according to MTU specifications.

Before putting the device or the system into operation, always ensure

- that all maintenance and repair work is completed
- that all loose components have been removed from rotating parts
- that nobody is standing in the danger zone of moving engine components.

Immediately after putting the device or system into operation, make sure that all control and display instruments as well as the signaling and alarm systems work properly.

Safety requirements for operators

Procedures for cases of emergency must be practised regularly.

The operator must be familiar with the controls and displays.

The operator must know the consequences of each operation to be carried out.

The operator must carry out the individual operations according to the documentation.

During operation, the displays and monitoring units must be permanently observed with regard to present operating status, violation of limit values and warning or alarm messages.

The following steps must be taken if a malfunction of the system is recognized or reported by the system:

- notify the supervisory personnel in charge
- analyze the message
- if required, carry out emergency operations e.g. emergency engine stop.

Engine operation

When the engine is running, always wear ear protectors.

Ensure that the engine room is well ventilated.

Mop up any leaked or spilt fluids and lubricants immediately or soak up with a suitable bonding agent.

Exhaust gases from combustion engines are poisonous. Inhalation of poisonous exhaust gases is a health hazard. The exhaust pipework must be free of leaks and discharge the gases to atmosphere.

During engine operation, do not touch battery terminals, generator terminals or cables.

Inadequate protection of electrical components can lead to electric shocks and serious injuries.

When the engine is running, never release coolant, oil, fuel, compressed-air or hydraulic lines.

Maintenance and repair

Strict adherence to the maintenance and repair schedule is an essential safety factor.

Never carry out maintenance and repair work with the engine running unless expressly instructed to do so.

Lock-out/tag-out the engine to preclude undesired starting. Disconnect the battery when electrical starters are fitted. Close the main valve on the compressed-air system and vent the compressed air line when air starters are fitted. Post the "Do Not Start" sign in the operating room or affix it to the controlling device! Persons not involved must keep clear.

Never attempt to rectify faults or carry out repairs if you do not have the necessary experience or special tools required. Have maintenance and repair work carried out by qualified and authorized personnel only.

Use only proper, calibrated tools.

Do not work on engines or components which are only held by lifting equipment or crane. Always support by suitable means which conform with the applicable regulations before commencing maintenance or repair work.

Before barring the engine, make sure that nobody is standing in the danger zone. After completing work on the engine, check that all protective devices/safety guards have been installed and that all tools and loose parts have been removed from the engine.

Fluids emerging under high pressure can penetrate clothing and skin and may cause serious injury. Before starting work, relieve pressure in systems and H.P. lines which are to be opened.

Never bend a fuel line and do not install bent lines. Keep fuel injection lines and connections clean.

Always seal connections with caps or covers if a line is removed or opened.

Take care not to damage fuel lines during maintenance and repair work. To tighten the connections when installing the lines, use the correct tightening torque and ensure that all retainers and dampers are installed correctly.

Ensure that all fuel injection lines and pressurized oil lines have sufficient distance to other components to avoid contact with them. Do not place fuel or oil lines near hot components, except when necessary for design reasons during installation.

Elastomers (e.g. "Viton" sealing rings) are stable under normal operating conditions. The material decomposes when exposed to fire or temperatures exceeding 300 °C. Hydrogen fluoride vapors are released in this case. The resulting acid leads to serious burning if it contacts the skin. Do not touch elastomeric seals if they have carbonized or resinous appearance. Wear protective gloves!

Take care with hot fluids in lines, pipes and chambers ⇒ Risk of injury!

Note cooling period for components which are heated for installation or removal ⇒ Risk of injury!

Never touch hot parts of the compressor and exhaust system ⇒ Risk of burning!

Take special care when removing ventilation or plugs from engine. In order to avoid discharge of highly pressurized liquids, hold a cloth over the screw or plug. It is even more dangerous if the engine has recently been shut down, as the liquids can still be hot.

Take special care when draining hot fluids. ⇒ Risk of injury!

When draining, collect fluids in a suitable container, mop up any spilt fluids or wipe or soak them with a suitable bonding agent.

When changing the engine oil or working on the fuel system, ensure that the engine room is adequately ventilated.

When working high on the engine, always use suitable ladders and work platforms. Make sure components are placed on stable surfaces.

In order to prevent back injuries when lifting heavy components adults, depending on age and sex, should only lift weights between max. 10 kg and 30 kg, therefore:

- Use lifting gear or seek assistance.
- Ensure that all chains, hooks, slings, etc. are tested and authorized, are sufficiently strong and that hooks are correctly positioned. Lifting eyes must not be unevenly loaded.

Observe special cleanliness when conducting maintenance and repair work on the engine plant. After completion of maintenance and repair work, make sure that no loose objects are in/on the engine plant.

Welding work

Never carry out welding work on the engine or engine-mounted units.

Never use the engine as a ground connection. This prevents the welding current passing through the engine resulting in burnt/scorched bearings, sliding surfaces and tooth flanks which may lead to bearing seizure and/or other material damage.

Never route the welding lead over or near the wiring harnesses of MTU systems. The welding current may otherwise induce an interference voltage in the wiring harnesses which could conceivably damage the electrical system.

The welding unit ground connection must not be more than 60 cm from the weld point.

If components (e.g. exhaust manifold) are to be welded, they must be removed from the engine.

It is not necessary to remove the connector and the connections when carrying out welding operation on MTU electronics if the master switch for power supply is switched from "ON" to "OFF" and the wire is disconnected from the negative and positive poles on the battery.

Hydraulic installation and removal

Only the hydraulic installation and removal equipment specified in the work schedule and in the assembly instructions must be used.

The max. permissible push-on pressure specified for the equipment must not be exceeded.

The H.P. lines for hydraulic installation and removal are tested with 3800 bar.

Do not attempt to bend or apply force to lines.

Before starting work, pay attention to the following:

- Vent the hydraulic installation/removal tool, the pumps and the lines at the relevant points for the system to be used (e.g. open vent plugs, pump until bubble-free air emerges, close vent plugs).
- For hydraulic installation, screw on the tool with the piston retracted.
- For hydraulic removal, screw on the tool with the piston extended.

For a hydraulic installation/removal tool with central expansion pressure supply, screw spindle into shaft end until correct sealing is achieved.

During hydraulic installation and removal, ensure that nobody is standing in the immediate vicinity of the component to be installed/removed. As long as the system is under pressure, there is the risk that the component to be installed/removed may be suddenly released from the pressure connection.

Before use, the tools must be checked at regular intervals (crack test).

Working on electrical/electronic assemblies

Always obtain the permission of the person in charge before commencing maintenance and repair work or switching off any part of the electronic system required to do so.

De-energize the appropriate areas prior to working on assemblies. Any measures requiring a power supply are expressly defined as such at the appropriate place in the manual.

Gases released from the battery are explosive. Avoid sparks and naked flames. Do not allow battery acids to come in contact with skin or clothing. Wear protective goggles. Do not place tools on the battery. Before connecting the cable to the battery, check battery polarity. Battery pole reversal may lead to injury through the sudden discharge of acid or bursting of the battery body.

Do not damage wiring during removal work and when reinstalling wiring and ensure that during operation it is not damaged by contact with sharp objects, by rubbing against other component or by a hot surface.

Do not secure wiring to fluid-carrying lines.

On completion of the maintenance and repair work, any cables which have become loose must be correctly connected and secured.

On completion of all repair work, the component and system must be subjected to a function check. Separate testing of the repaired component without system integration is insufficient.

If wires are installed beside mechanical components and there is a risk of chafing, use cable clamps to properly support the wires.

For this purpose, no cable binders must be used as, during maintenance and / or repair work, the binders can be removed but not installed a second time.

Spare parts shall be properly stored prior to replacement, i.e. particularly protected against moisture. Defective electronic components and assemblies must be suitably packed when dispatched for repair, i.e. particularly protected against moisture and impact and wrapped in antistatic foil if necessary.

Working with laser equipment

When working with laser equipment, always wear special laser-protection goggles.

Laser equipment can generate extremely intensive, concentrated radiation by the effect of stimulated emission in the range of visible light or in the infrared or ultraviolet spectral range. The photochemical, thermal and optomechanical effects of the laser can cause damage. The main danger is irreparable damage to the eyes.

Laser equipment must be fitted with the protective devices necessary for safe operation according to type and application.

For conducting light-beam procedures and measurement work, only the following laser devices must be used:

- Laser devices of classes 1, 2 or 3A,
- Laser devices of class 3B, which have maximum output in the visible wavelength range (400 to 700 nm), a maximum output of 5 mW, and in which the beam axis and surface are designed to prevent any risk to the eyes.

Operation of electrical equipment

When operating electrical equipment, certain components of this equipment are live.

Noncompliance with the warning instructions given for this equipment may result in serious injury or damage to property.

1.5 Auxiliary materials, fire prevention and environmental protection

Fire prevention

Rectify any fuel or oil leaks immediately; even splashes of oil or fuel on hot components can cause fires - therefore always keep the engine in a clean condition. Do not leave cloths soaked with fluids and lubricants lying around on the engine. Do not store combustible materials near the engine.

Do not carry out welding work on pipes and components carrying oil or fuel. Before welding, clean with a noncombustible fluid.

When starting the engine with a foreign power source, connect the ground lead last and remove it first.

To avoid sparks in the vicinity of the battery, connect the ground lead from the foreign power source to the ground lead of the engine or to the ground terminal of the starter.

Always keep suitable fire-fighting equipment (fire extinguishers) at hand and familiarize yourself with their use.

Noise

Noise can lead to an increased risk of accident if acoustic signals, warning shouts or sounds indicating danger are drowned.

At all workplaces with a sound pressure level over 85 dB (A), always wear ear protectors (protective wadding, plugs or capsules).

Environmental protection

Dispose of used fluids, lubricants, materials and filters in accordance with local regulations.

Manipulation of the injection control system can influence the engine performance and exhaust emissions.

As a result, compliance with environmental regulations may no longer be guaranteed.

Only fuels of the specified quality required to achieve emission limits must be used.

In Germany, the VAWS (= regulations governing the use of materials that may affect water quality) is applicable, which means work must only be carried out by authorized specialist companies (MTU is such a company).

Auxiliary materials

Use only fluids and lubricants that have been tested and approved by MTU.

Fluids and lubricants must be kept in suitable, properly designated containers. When using fluids, lubricants and other chemical substances, follow the safety instructions applicable to the product. Take care when handling hot, chilled or caustic materials. When using inflammable materials, avoid sparks, flames and do not smoke.

Lead

- When working with lead or lead-containing pastes, avoid direct contact to the skin and do not inhale lead vapors.
- Adopt suitable measures to avoid the formation of lead dust!
- Switch on fume extraction system.
- After coming into contact with lead or lead-containing materials, wash hands!

Acids and alkaline solutions

- When working with acids and alkalis, wear protective goggles or face mask, gloves and protective clothing.
- Immediately remove clothing wetted by acids and alkalis!
- Rinse injuries with plenty of water!
- Rinse eyes immediately with eyedrops or clean tap water.

Paints

- When painting anywhere other than in spray booths equipped with extractors, ensure good ventilation. Make sure that adjacent work areas are not affected.
- No naked flames!
- No smoking.
- Observe fire prevention regulations!
- Wear masks providing protection against paint and solvent fumes.

Liquid nitrogen

- Store liquid nitrogen only in small quantities and always in regulation containers without fixed covers.
- Do not bring liquid nitrogen in contact with the body (eyes, hands), as this causes frostbite and loss of tissue.
- Wear protective clothing, including gloves, closed shoes and protective goggles!

- Ensure that the room is well ventilated. Nitrogen concentration exceeding 88% of breathing air leads to suffocation.
- Avoid all knocks and jars to the containers, fixtures or workpieces.

Compressed air

Compressed air is air compressed at excess pressure and is stored in vessels from which it can be extracted.

The pressure at which the air is kept can be read off at pressure gauges which must be connected to the compressed air vessels and the compressed air lines.

When working with compressed air, safety precautions must be constantly observed:

- Pay special attention to the pressure level in the compressed air network and pressure vessel!
- Devices and equipment connected must either be designed for this pressure or, if the permitted pressure for the connected elements is lower than the pressure required, a pressure reducing valve and safety valve (set to permitted pressure) must form an intermediate connection. Hose coupling and connections must be securely attached!
- Always wear protective goggles when blowing off tools or chips!
- The snout of the air nozzle should be provided with a protective disc (e.g. rubber disc), which prevents air-borne particles being deflected and thereby prevents injury to eyes.
- First shut off compressed air lines before compressed air equipment is disconnected from the supply line or before equipment or tools are exchanged!
- Unauthorized use of compressed air, e.g. forcing flammable liquids (hazard class A1, A11 and B) out of containers, carries the risk of explosion!
- Forcing compressed air into thin-walled containers (e.g. containers made of tin, plastic and glass) for drying purposes or to check for leaks, results in a risk of shattering!
- Do not use compressed air to clean contaminated clothing whilst it is being worn.



Used oil

Used oil may contain health-threatening combustion residues.

Rub barrier cream into hands!

Wash hands after contact with used oil.

1.6 Standards for warning notices in the publication

 DANGER	In the event of immediate danger. Consequences: Death or serious injury. <ul style="list-style-type: none"> • Preventive measures
 WARNING	In the event of possibly dangerous situations. Consequences: Death or serious injury. <ul style="list-style-type: none"> • Preventive measures
 CAUTION	In the event of dangerous situations. Consequences: Slight injury or material damage. <ul style="list-style-type: none"> • Preventive measures

Note: This Publication contains especially emphasized safety instructions in accordance with the American standard ANSI Z535, which begin with one of the above signal words according to the degree of danger:

Warning notices

1. Read and become acquainted with all cautions and symbols before operating or repairing this product.
2. Pass on all safety instructions to your operating, maintenance, repair and transport personnel!

2 Product Summary

2.1 Engine Layout

2.1.1 Engine layout

Illustration is also valid for 12V 4000 Gx3 engines

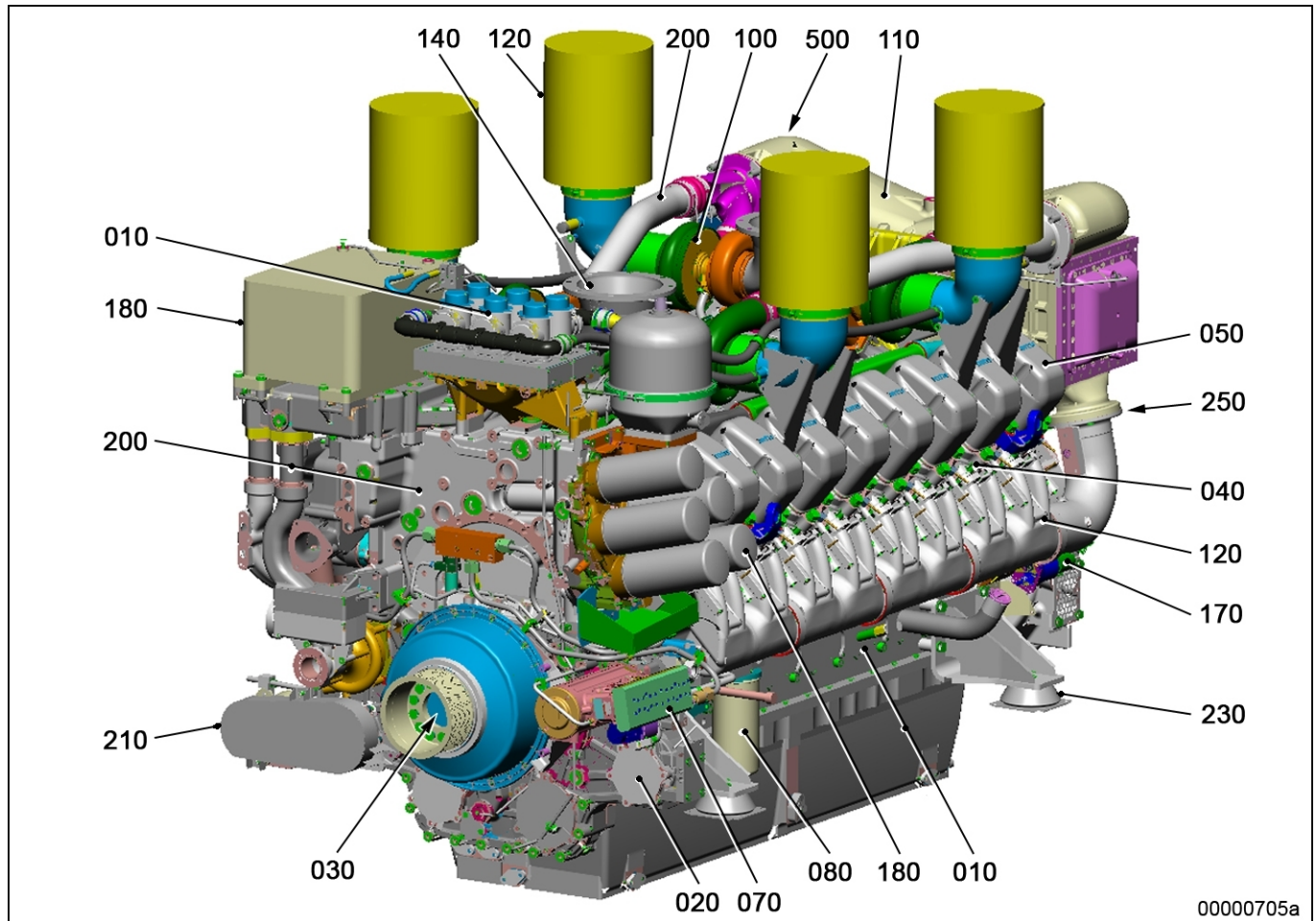

- | | |
|---------------------------------|--|
| 010 Crankcase and attachments | 140 Exhaust system |
| 020 Gear train | 170 Starting equipment |
| 030 Running gear | 180 Lube oil system |
| 040 Cylinder head | 200 Coolant system |
| 050 Valve gear | 210 Power supply |
| 070 Fuel system (high pressure) | 230 Mounting / support |
| 080 Fuel system (low pressure) | 250 PTO systems, driving end and free end (coupling) |
| 100 Exhaust turbocharger | 500 Monitoring and control systems, general electrical systems |
| 110 Intercooler | |
| 120 Air intake / air supply | |

00000705a

Engine model designation

Key to the engine model designations 12/16V 4000 Gx3

12/16	Number of cylinders
V	Cylinder arrangement: Vee configuration
4000	Series
G	Application
x	Application segment (2, 4, 6, 8)
3	Design index

2.2 Engine Side and Cylinder Designations

2.2.1 Engine side and cylinder designations

Engine sides are always designated as viewed from the driving end (KS).

The cylinders of the left engine side are designated "A" and those of the right side "B" (as per DIN ISO 1204). The cylinders of each bank are numbered consecutively, starting with No. 1 at the driving end.

The numbering of engine components is also from the driving end, starting with No. 1.

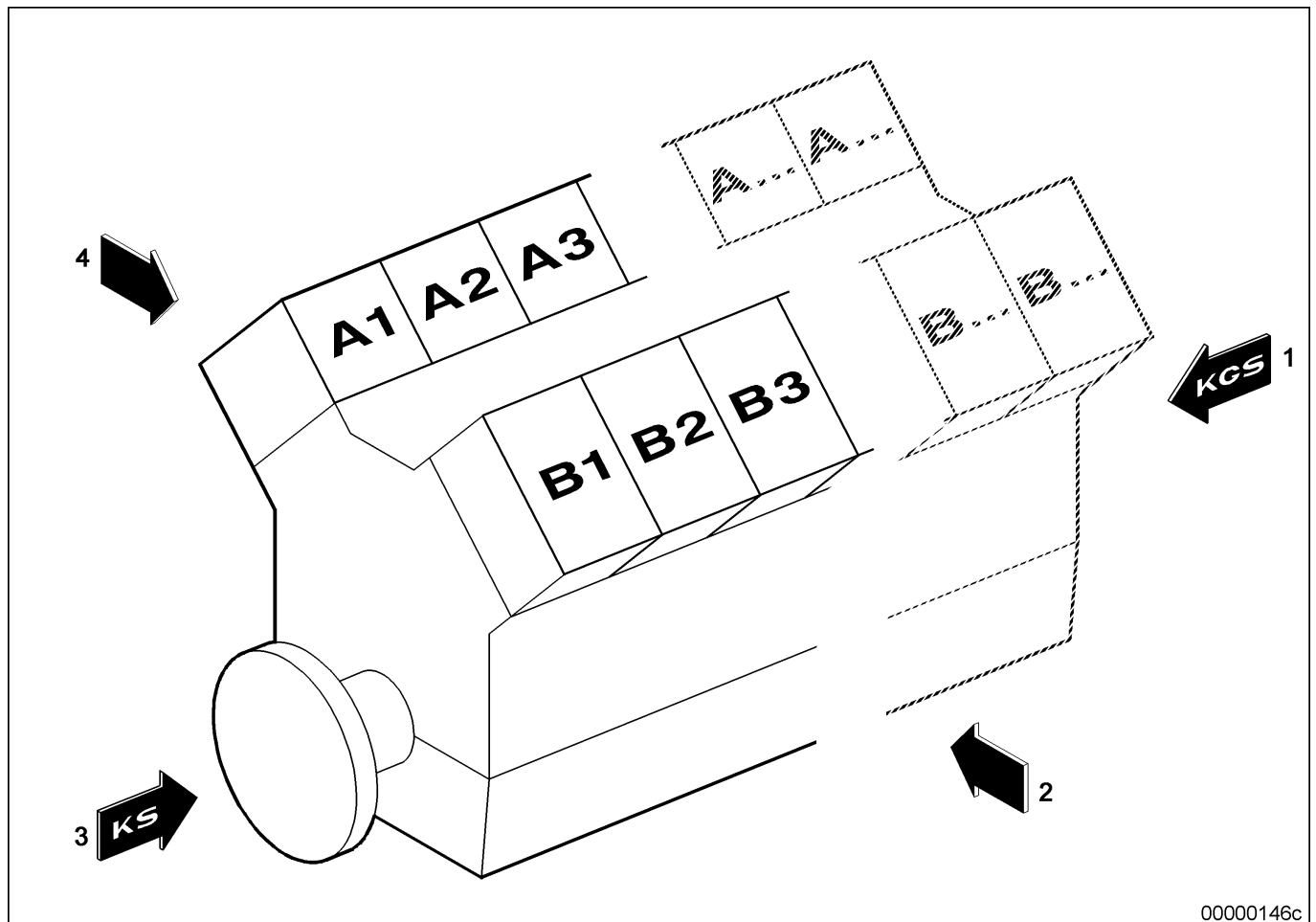

00000146c

1 KGS = Free end
2 Right side

3 KS = Driving end
4 Left side

2.3 Main Engine Dimensions

2.3.1 Engine – Main dimensions

Engine – Main dimensions

Illustration is also valid for 12/16V engines

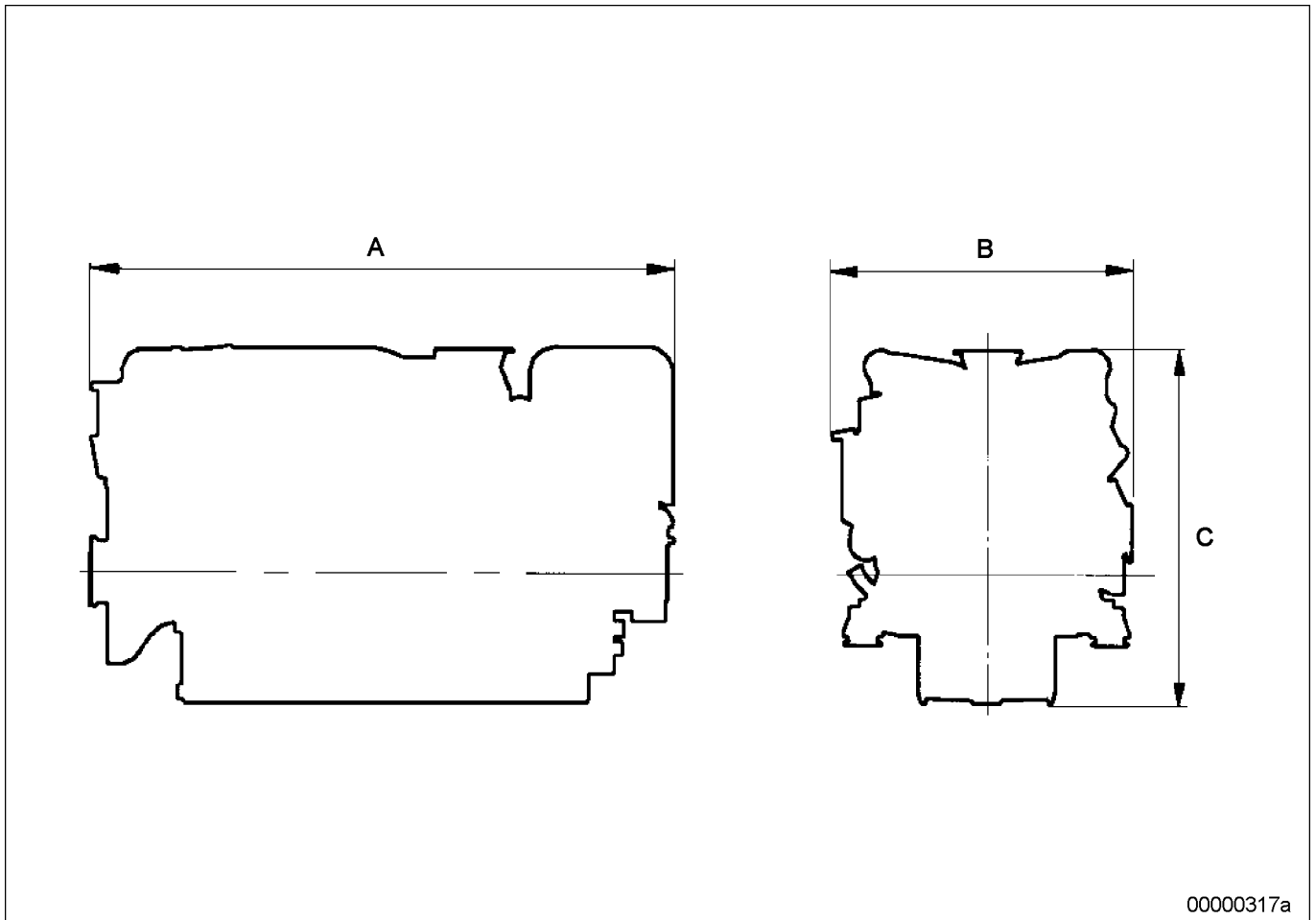

00000317a

Length (A) 12V	approx. 2520 mm
Length (A) 16V	approx. 2990 mm
Width (B) 12/16V	approx. 1660 mm
Height (C) 12/16V	approx. 2160 mm

2.4 Firing Order

2.4.1 Firing order

Firing order

12V	A1-B5-A5-B3-A3-B6-A6-B2-A2-B4-A4-B1
16 V	A1-A7-B4-B6-A4-B8-A2-A8-B3-B5-A3-A5-B2-A6-B1-B7
20V	A1-B5-A8-B7-A5-B2-A7-B10-A2-B3-A10-B6-A3-B4-A6-B9-A4-B1-A9-B8

2.5 Final Compression Pressure

2.5.1 Final compression pressure

Final compression pressure

Final compression pressure at 120 rpm	24 bar to 28 bar
---------------------------------------	------------------

2.6 Technical Data

2.6.1 12V 4000 Gx3 engine data: Standby operation 3D, optimized fuel consumption

Explanation:

DL Ref. value: Continuous power

BL Ref. value: Fuel stop power

A Design value

G Guaranteed value

R Guideline value

L Limit value, up to which the engine can be operated, without change (e.g. of power settings).

N Not yet defined value

- Not applicable

X Applicable

REFERENCE CONDITIONS

Engine model			12V 4000 G23	12V 4000 G43	12V 4000 G63	12V 4000 G83
Application group			3D	3D	3D	3D
Intake air temperature		°C	25	25	25	25
Charge-air coolant temperature		°C	55	55	55	55
Raw water inlet temperature		°C	-	-	-	-
Barometric pressure		mbar	1000	1000	1000	1000
Site altitude above sea level		m	100	100	100	100

POWER-RELATED DATA (performance refers to net brake power as per ISO 3046)

Number of cylinders			12	12	12	12
Rated engine speed	A	rpm	1500	1800	1500	1800
Fuel stop power ISO 3046	A	kW	1575	1736	1750	1910

GENERAL CONDITIONS (for maximum power)

Number of cylinders			12	12	12	12
Intake air depression (new filter)	A	mbar	15	15	15	15
Intake air depression, max.	L	mbar	50	50	50	50
Exhaust pressure	A	mbar	30	30	30	30
Exhaust pressure, max.	L	mbar	85	85	85	85

MODEL RELATED DATA (basic design)

Number of cylinders			12	12	12	12
Engine with exhaust turbocharging (ETC) and charge air cooling (CAC)			X	X	X	X
Exhaust piping, non-cooled			X	X	X	X
Working method: four-cycle, diesel, single-acting			X	X	X	X
Combustion method: Direct fuel injection			X	X	X	X
Cooling system: conditioned water			X	X	X	X
Direction of rotation: c.c.w. (facing driving end)			X	X	X	X
Number of cylinders			12	12	12	12
Cylinder arrangement: V angle		Degrees	90	90	90	90
Bore		mm	170	170	170	170
Stroke		mm	210	210	210	210
Displacement per cylinder		liters	4.77	4.77	4.77	4.77
Total displacement		liters	57.2	57.2	57.2	57.2
Compression ratio			16.5	16.5	16.5	16.5
Cylinder heads: single-cylinder			X	X	X	X
Cylinder liners: Wet, replaceable			X	X	X	X
Inlet valves per cylinder			2	2	2	2
Exhaust valves per cylinder			2	2	2	2
Standard flywheel housing flange (engine main PTO)		SAE	00	00	00	00
Flywheel interface		DISC	21	21	21	21

COMBUSTION AIR / EXHAUST GAS

Number of cylinders			12	12	12	12
Charge air pressure before cylinder, BL	R	bar abs	2.9	3.2	3.2	3.4

COOLANT SYSTEM (HT circuit)

Number of cylinders			12	12	12	12
Coolant temperature (at engine connection: outlet to cooling equipment)	A	°C	100	100	100	100
Coolant temperature after engine, alarm	R	°C	102	102	102	102
Coolant temperature after engine, shutdown	L	°C	104	104	104	104
Coolant antifreeze content, max.	L	%	50	50	50	50
Pressure loss in off-engine cooling system, max.	L	bar	0.7	0.7	0.7	0.7

COOLING SYSTEM (LT circuit)

Number of cylinders			12	12	12	12
Coolant temperature before intercooler (at engine inlet from cooling equipment)	A	°C	55	55	55	55
Coolant antifreeze content, max.	L	%	50	50	50	50
Pressure loss in off-engine cooling system, max.	L	bar	0.7	0.7	0.7	0.7

LUBE-OIL SYSTEM

Number of cylinders			12	12	12	12
Lube oil operating temperature before engine, from	R	°C	88	88	88	88
Lube-oil operating temperature before engine, to	R	°C	98	98	98	98
Lube oil temperature before engine, alarm	R	°C	99	99	99	99
Lube oil temperature before engine, shutdown	L	°C	101	101	101	101
Lube oil operating pressure before engine, from	R	bar	5.0	5.0	5.0	5.0
Lube oil operating pressure before engine, to	R	bar	7.0	7.0	7.0	7.0
Lube oil pressure before engine, alarm	R	bar	--	--	--	--
Lube oil pressure before engine, shutdown	L	bar	--	--	--	--

FUEL SYSTEM

Number of cylinders			12	12	12	12
Fuel pressure at engine supply connection, min. (when engine is starting)	L	bar	-0.1	-0.1	-0.1	-0.1
Fuel pressure at engine supply connection, max. (when engine is starting)	L	bar	1.5	1.5	1.5	1.5

GENERAL OPERATING DATA

Number of cylinders			12	12	12	12
Cold start capability: Air temperature (w/o start aid, w/o preheating) - (case A)	R	°C	10	10	10	10
Coolant preheating, preheating temperature (min.)	R	°C	32	32	32	32
Firing speed, from	R	rpm	80	80	80	80
Firing speed, to	R	rpm	120	120	120	120

CAPACITIES

Number of cylinders			12	12	12	12
Engine coolant capacity, engine side (without cooling equipment)	R	liters	160	160	160	160
Charge-air coolant, engine side	R	liters	40	40	40	40
Total engine oil capacity at initial filling (standard oil system) (Option: max. operating inclinations)	R	liters	260	260	260	260
Oil change quantity, max. (standard oil system) (Option: max. operating inclinations)	R	liters				
Oil pan capacity at dipstick mark "min." (standard oil system) (Option: max. operating inclinations)	L	liters	160	160	160	160
Oil pan capacity at dipstick mark "max." (standard oil system) (Option: max. operating inclinations)	L	liters	200	200	200	200

WEIGHTS / MAIN DIMENSIONS

Number of cylinders			12	12	12	12
Engine weight, dry (basic engine configuration acc. to scope of supply specification)	R	kg	6200*	6200*	6200*	6200*

ACOUSTICS

Number of cylinders			12	12	12	12
Exhaust noise, unsilenced, BL, (sound power level LW, ISO 6798)	R	dB(A)	125	127	126	129
Engine surface noise with attenuated intake noise (filter), BL (sound power level LW, ISO 6798)	R	dB(A)	121	123	122	124

2.6.2 16V 4000 Gx3 engine data: Standby operation 3D, optimized fuel consumption

Explanation:

DL Ref. value: Continuous power

BL Ref. value: Fuel stop power

A Design value

G Guaranteed value

R Guideline value

L Limit value, up to which the engine can be operated, without change (e.g. of power settings).

N Not yet defined value

- Not applicable

X Applicable

REFERENCE CONDITIONS

Engine model			16 V 4000 G23	16 V 4000 G43	16 V 4000 G63	16 V 4000 G83
Application group			3D	3D	3D	3D
Intake air temperature		°C	25	25	25	25
Charge-air coolant temperature		°C	55	55	55	55
Raw water inlet temperature		°C	-	-	-	-
Barometric pressure		mbar	1000	1000	1000	1000
Site altitude above sea level		m	100	100	100	100

POWER-RELATED DATA (performance refers to net brake power as per ISO 3046)

Number of cylinders			16	16	16	16
Rated engine speed	A	rpm	1500	1800	1500	1800
Fuel stop power ISO 3046	A	kW	1965	2280	2185	2500

GENERAL CONDITIONS (for maximum power)

Number of cylinders			16	16	16	16
Intake air depression (new filter)	A	mbar	15	15	15	15
Intake air depression, max.	L	mbar	50	50	50	50
Exhaust pressure	A	mbar	30	30	30	30
Exhaust pressure, max.	L	mbar	85	85	85	85

MODEL RELATED DATA (basic design)

Number of cylinders			16	16	16	16
Engine with exhaust turbocharging (ETC) and charge air cooling (CAC)			X	X	X	X
Exhaust piping, non-cooled			X	X	X	X
Working method: four-cycle, diesel, single-acting			X	X	X	X
Combustion method: Direct fuel injection			X	X	X	X
Cooling system: conditioned water			X	X	X	X
Direction of rotation: c.c.w. (facing driving end)			X	X	X	X
Number of cylinders			16	16	16	16
Cylinder arrangement: V angle		Degrees	90	90	90	90
Bore		mm	170	170	170	170
Stroke		mm	210	210	210	210
Displacement per cylinder		liters	4.77	4.77	4.77	4.77
Total displacement		liters	76.3	76.3	76.3	76.3
Compression ratio			16.5	16.5	16.5	16.5
Cylinder heads: single-cylinder			X	X	X	X
Cylinder liners: Wet, replaceable			X	X	X	X
Inlet valves per cylinder			2	2	2	2
Exhaust valves per cylinder			2	2	2	2
Standard flywheel housing flange (engine main PTO)		SAE	00	00	00	00
Flywheel interface		DISC	21	21	21	21

COMBUSTION AIR / EXHAUST GAS

Number of cylinders			16	16	16	16
Charge air pressure before cylinder, BL	R	bar abs	2.8	3.1	3.1	3.3

COOLANT SYSTEM (HT circuit)

Number of cylinders			16	16	16	16
Coolant temperature (at engine connection: outlet to cooling equipment)	A	°C	100	100	100	100
Coolant temperature after engine, alarm	R	°C	102	102	102	102
Coolant temperature after engine, shutdown	L	°C	104	104	104	104
Coolant antifreeze content, max.	L	%	50	50	50	50
Pressure loss in off-engine cooling system, max.	L	bar	0.7	0.7	0.7	0.7

COOLING SYSTEM (LT circuit)

Number of cylinders			16	16	16	16
Coolant temperature before intercooler (at engine inlet from cooling equipment)	A	°C	55	55	55	55
Coolant antifreeze content, max.	L	%	50	50	50	50
Pressure loss in off-engine cooling system, max.	L	bar	0.7	0.7	0.7	0.7

LUBE-OIL SYSTEM

Number of cylinders			16	16	16	16
Lube oil operating temperature before engine, from	R	°C	89	88	88	88
Lube-oil operating temperature before engine, to	R	°C	95	95	94	94
Lube oil temperature before engine, alarm	R	°C	97	97	97	97
Lube oil temperature before engine, shutdown	L	°C	99	99	99	99
Lube oil operating pressure before engine, from	R	bar	4.2	4.7	4.2	4.7
Lube oil operating pressure before engine, to	R	bar	5.5	6.5	5.5	6.5
Lube oil pressure before engine, alarm	R	bar	--	--	--	--
Lube oil pressure before engine, shutdown	L	bar	--	--	--	--

FUEL SYSTEM

Number of cylinders			16	16	16	16
Fuel pressure at engine supply connection, min. (when engine is starting)	L	bar	-0.1	-0.1	-0.1	-0.1
Fuel pressure at engine supply connection, max. (when engine is starting)	L	bar	1.5	1.5	1.5	1.5

GENERAL OPERATING DATA

Number of cylinders			16	16	16	16
Cold start capability: Air temperature (w/o start aid, w/o preheating) - (case A)	R	°C	10	10	10	10
Coolant preheating, preheating temperature (min.)	R	°C	32	32	32	32
Firing speed, from	R	rpm	80	80	80	80
Firing speed, to	R	rpm	120	120	120	120

CAPACITIES

Number of cylinders			16	16	16	16
Engine coolant capacity, engine side (without cooling equipment)	R	liters	260	260	260	260
Charge-air coolant, engine side	R	liters	50	50	50	50
Total engine oil capacity at initial filling (standard oil system) (Option: max. operating inclinations)	R	liters	300	300	300	300
Oil change quantity, max. (standard oil system) (Option: max. operating inclinations)	R	liters	240	240	240	240
Oil pan capacity at dipstick mark "min." (standard oil system) (Option: max. operating inclinations)	L	liters	210	210	210	210
Oil pan capacity at dipstick mark "max." (standard oil system) (Option: max. operating inclinations)	L	liters	240	240	240	240

WEIGHTS / MAIN DIMENSIONS

Number of cylinders			16	16	16	16
Engine weight, dry (basic engine configuration acc. to scope of supply specification)	R	kg	7700	7700	7700	7700

ACOUSTICS

Number of cylinders			16	16	16	16
Exhaust noise, unsilenced, BL, (sound power level LW, ISO 6798)	R	dB(A)	126	129	128	130
Engine surface noise with attenuated intake noise (filter), BL (sound power level LW, ISO 6798)	R	dB(A)	128	125	125	126

2.6.3 Engine data 12/16V 4000 Gx3: Standby operation 3D, optimized exhaust emissions (EPA stage 2)

Explanation:

DL Ref. value: Continuous power

BL Ref. value: Fuel stop power

A Design value

G Guaranteed value

R Guideline value

L Limit value, up to which the engine can be operated, without change (e.g. of power settings).

N Not yet defined value

- Not applicable

X Applicable

REFERENCE CONDITIONS

Engine model			12V	12V	16 V	16 V
			4000 G43	4000 G83	4000 G43	4000 G83
Application group			3D	3D	3D	3D
Intake air temperature		°C	25	25	25	25
Charge-air coolant temperature		°C	45	45	45	45
Raw water inlet temperature		°C	-	-	-	-
Barometric pressure		mbar	1000	1000	1000	1000
Site altitude above sea level		m	100	100	100	100

POWER-RELATED DATA (performance refers to net brake power as per ISO 3046)

Number of cylinders			12	12	16	16
Rated engine speed	A	rpm	1800	1800	1800	1800
Fuel stop power ISO 3046	A	kW	1736	1910	2280	2500

GENERAL CONDITIONS (for maximum power)

Number of cylinders			12	12	16	16
Intake air depression (new filter)	A	mbar	15	15	15	15
Intake air depression, max.	L	mbar	50	50	50	50
Exhaust pressure	A	mbar	30	30	30	30
Exhaust pressure, max.	L	mbar	85	85	85	85

MODEL RELATED DATA (basic design)

Number of cylinders			12	12	16	16
Engine with exhaust turbocharging (ETC) and charge air cooling (CAC)			X	X	X	X
Exhaust piping, non-cooled			X	X	X	X
Working method: four-cycle, diesel, single-acting			X	X	X	X
Combustion method: Direct fuel injection			X	X	X	X
Cooling system: conditioned water			X	X	X	X
Direction of rotation: c.c.w. (facing driving end)			X	X	X	X
Number of cylinders			12	12	16	16
Cylinder arrangement: V angle		Degrees	90	90	90	90
Bore		mm	170	170	170	170
Stroke		mm	210	210	210	210
Displacement per cylinder		liters	4.77	4.77	4.77	4,77
Total displacement		liters	57.2	57.2	76,3	76.3
Compression ratio			16.5	16.5	16.5	16.5
Cylinder heads: single-cylinder			X	X	X	X
Cylinder liners: Wet, replaceable			X	X	X	X
Inlet valves per cylinder			2	2	2	2
Exhaust valves per cylinder			2	2	2	2
Standard flywheel housing flange (engine main PTO)		SAE	00	00	00	00
Flywheel interface		DISC	21	21	21	21

COMBUSTION AIR / EXHAUST GAS

Number of cylinders			12	12	16	16
Charge air pressure before cylinder, BL	R	bar abs	3.2	3.3	3.2	3.3

COOLANT SYSTEM (HT circuit)

Number of cylinders			12	12	16	16
Coolant temperature (at engine connection: outlet to cooling equipment)	A	°C	100	100	100	100
Coolant temperature after engine, alarm	R	°C	102	102	102	102
Coolant temperature after engine, shutdown	L	°C	104	104	104	104
Coolant antifreeze content, max.	L	%	50	50	50	50
Pressure loss in off-engine cooling system, max.	L	bar	0.7	0.7	0.7	0.7

COOLING SYSTEM (LT circuit)

Number of cylinders			12	12	16	16
Coolant temperature before intercooler (at engine inlet from cooling equipment)	A	°C	45	45	45	45
Coolant antifreeze content, max.	L	%	50	50	50	50
Pressure loss in off-engine cooling system, max.	L	bar	0.7	0.7	0.7	0.7

LUBE-OIL SYSTEM

Number of cylinders			12	12	16	16
Lube oil operating temperature before engine, from	R	°C	88	88	88	88
Lube-oil operating temperature before engine, to	R	°C	98	98	94	94
Lube oil temperature before engine, alarm	R	°C	99	99	97	97
Lube oil temperature before engine, shutdown	L	°C	101	101	99	99
Lube oil operating pressure before engine, from	R	bar	5.0	5.0	4.7	4.7
Lube oil operating pressure before engine, to	R	bar	7.0	7.0	6.5	6.5
Lube oil pressure before engine, alarm	R	bar	--	--	--	--
Lube oil pressure before engine, shutdown	L	bar	--	--	--	--

FUEL SYSTEM

Number of cylinders			12	12	16	16
Fuel pressure at engine supply connection, min. (when engine is starting)	L	bar	-0.1	-0.1	-0.1	-0.1
Fuel pressure at engine supply connection, max. (when engine is starting)	L	bar	1.5	1.5	1.5	1.5

GENERAL OPERATING DATA

Number of cylinders			12	12	16	16
Cold start capability: Air temperature (w/o start aid, w/o preheating) - (case A)	R	°C	10	10	10	10
Coolant preheating, preheating temperature (min.)	R	°C	32	32	32	32
Firing speed, from	R	rpm	80	80	80	80
Firing speed, to	R	rpm	120	120	120	120

CAPACITIES

Number of cylinders			12	12	16	16
Engine coolant capacity, engine side (without cooling equipment)	R	liters	160	160	260	260
Charge-air coolant, engine side	R	liters	40	40	50	50
Total engine oil capacity at initial filling (standard oil system) (Option: max. operating inclinations)	R	liters	260	260	300	300
Oil change quantity, max. (standard oil system) (Option: max. operating inclinations)	R	liters			240	240
Oil pan capacity at dipstick mark "min." (standard oil system) (Option: max. operating inclinations)	L	liters	160	160	210	210
Oil pan capacity at dipstick mark "max." (standard oil system) (Option: max. operating inclinations)	L	liters	200	200	240	240

WEIGHTS / MAIN DIMENSIONS

Number of cylinders			12	12	16	16
Engine weight, dry (basic engine configuration acc. to scope of supply specification)	R	kg	6200*	6200*	7700	7700

ACOUSTICS

Number of cylinders			12	12	16	16
Exhaust noise, unsilenced, BL, (sound power level LW, ISO 6798)	R	dB(A)	127	129	129	130
Engine surface noise with attenuated intake noise (filter), BL (sound power level LW, ISO 6798)	R	dB(A)	123	124	125	126

2.6.4 12V 4000 Gx3 engine data: Continuous operation, variable 3B, optimized fuel consumption

Explanation:

DL Ref. value: Continuous power

BL Ref. value: Fuel stop power

A Design value

G Guaranteed value

R Guideline value

L Limit value, up to which the engine can be operated, without change (e.g. of power settings).

N Not yet defined value

- Not applicable

X Applicable

REFERENCE CONDITIONS

Engine model			12V 4000 G23	12V 4000 G43	12V 4000 G63	12V 4000 G83
Application group			3B	3B	3B	3B
Intake air temperature		°C	25	25	25	25
Charge-air coolant temperature		°C	55	55	55	55
Raw water inlet temperature		°C	-	-	-	-
Barometric pressure		mbar	1000	1000	1000	1000
Site altitude above sea level		m	100	100	100	100

POWER-RELATED DATA (performance refers to net brake power as per ISO 3046)

Number of cylinders			12	12	12	12
Rated engine speed	A	rpm	1500	1800	1500	1800
Continuous power ISO 3046 (10% overload capability) (design power DIN 6280, ISO 8528)	A	kW	1420	1520	1575	1736

GENERAL CONDITIONS (for maximum power)

Number of cylinders			12	12	12	12
Intake air depression (new filter)	A	mbar	15	15	15	15
Intake air depression, max.	L	mbar	50	50	50	50
Exhaust pressure	A	mbar	30	30	30	30
Exhaust pressure, max.	L	mbar	85	85	85	85

MODEL RELATED DATA (basic design)

Number of cylinders			12	12	12	12
Engine with exhaust turbocharging (ETC) and charge air cooling (CAC)			X	X	X	X
Exhaust piping, non-cooled			X	X	X	X
Working method: four-cycle, diesel, single-acting			X	X	X	X
Combustion method: Direct fuel injection			X	X	X	X
Cooling system: conditioned water			X	X	X	X
Direction of rotation: c.c.w. (facing driving end)			X	X	X	X
Number of cylinders			12	12	12	12
Cylinder arrangement: V angle		Degrees	90	90	90	90
Bore		mm	170	170	170	170
Stroke		mm	210	210	210	210
Displacement per cylinder		liters	4.77	4.77	4.77	4.77
Total displacement		liters	57.2	57.2	57.2	57.2
Compression ratio			16.5	16.5	16.5	16.5
Cylinder heads: single-cylinder			X	X	X	X
Cylinder liners: Wet, replaceable			X	X	X	X
Inlet valves per cylinder			2	2	2	2
Exhaust valves per cylinder			2	2	2	2
Standard flywheel housing flange (engine main PTO)		SAE	00	00	00	00
Flywheel interface		DISC	21	21	21	21

COMBUSTION AIR / EXHAUST GAS

Number of cylinders			12	12	12	12
Charge air pressure before cylinder - DL	R	bar abs	2.6	2.9	2.9	3.2

COOLANT SYSTEM (HT circuit)

Number of cylinders			12	12	12	12
Coolant temperature (at engine connection: outlet to cooling equipment)	A	°C	100	100	100	100
Coolant temperature after engine, alarm	R	°C	102	102	102	102
Coolant temperature after engine, shutdown	L	°C	104	104	104	104
Coolant antifreeze content, max.	L	%	50	50	50	50
Pressure loss in off-engine cooling system, max.	L	bar	0.7	0.7	0.7	0.7

COOLING SYSTEM (LT circuit)

Number of cylinders			12	12	12	12
Coolant temperature before intercooler (at engine inlet from cooling equipment)	A	°C	55	55	55	55
Coolant antifreeze content, max.	L	%	50	50	50	50
Pressure loss in off-engine cooling system, max.	L	bar	0.7	0.7	0.7	0.7

LUBE-OIL SYSTEM

Number of cylinders			12	12	12	12
Lube oil operating temperature before engine, from	R	°C	88	88	88	88
Lube-oil operating temperature before engine, to	R	°C	98	98	98	98
Lube oil temperature before engine, alarm	R	°C	99	99	99	99
Lube oil temperature before engine, shutdown	L	°C	101	101	101	101
Lube oil operating pressure before engine, from	R	bar	5.0	5.0	5.0	5.0
Lube oil operating pressure before engine, to	R	bar	6.0	7.0	7.0	7.0
Lube oil pressure before engine, alarm	R	bar	--	--	--	--
Lube oil pressure before engine, shutdown	L	bar	--	--	--	--

FUEL SYSTEM

Number of cylinders			12	12	12	12
Fuel pressure at engine supply connection, min. (when engine is starting)	L	bar	-0.1	-0.1	-0.1	-0.1
Fuel pressure at engine supply connection, max. (when engine is starting)	L	bar	1.5	1.5	1.5	1.5

GENERAL OPERATING DATA

Number of cylinders			12	12	12	12
Cold start capability: Air temperature (w/o start aid, w/o preheating) - (case A)	R	°C	10	10	10	10
Coolant preheating, preheating temperature (min.)	R	°C	32	32	32	32
Firing speed, from	R	rpm	80	80	80	80
Firing speed, to	R	rpm	120	120	120	120

CAPACITIES

Number of cylinders			12	12	12	12
Engine coolant capacity, engine side (without cooling equipment)	R	liters	160	160	160	160
Charge-air coolant, engine side	R	liters	40	40	40	40
Total engine oil capacity at initial filling (standard oil system) (Option: max. operating inclinations)	R	liters	260	260	260	260
Oil change quantity, max. (standard oil system) (Option: max. operating inclinations)	R	liters				
Oil pan capacity at dipstick mark "min." (standard oil system) (Option: max. operating inclinations)	L	liters	160	160	160	160
Oil pan capacity at dipstick mark "max." (standard oil system) (Option: max. operating inclinations)	L	liters	200	200	200	200

WEIGHTS / MAIN DIMENSIONS

Number of cylinders			12	12	12	12
Engine weight, dry (basic engine configuration acc. to scope of supply specification)	R	kg	6200*	6200*	6200*	6200*

ACOUSTICS

Number of cylinders			12	12	12	12
Exhaust noise, unsilenced - DL (sound power level LW, ISO 6798)	R	dB(A)	124	125	125	127
Engine surface noise with attenuated intake noise (filter), DL (sound power level LW, ISO 6798)	R	dB(A)	120	122	121	123

2.6.5 16V 4000 Gx3 engine data: Continuous operation, variable 3B, optimized fuel consumption

Explanation:

DL Ref. value: Continuous power

BL Ref. value: Fuel stop power

A Design value

G Guaranteed value

R Guideline value

L Limit value, up to which the engine can be operated, without change (e.g. of power settings).

N Not yet defined value

- Not applicable

X Applicable

REFERENCE CONDITIONS

Engine model			16 V 4000 G23	16 V 4000 G43	16 V 4000 G63	16 V 4000 G83
Application group			3B	3B	3B	3B
Intake air temperature		°C	25	25	25	25
Charge-air coolant temperature		°C	55	55	55	55
Raw water inlet temperature		°C	-	-	-	-
Barometric pressure		mbar	1000	1000	1000	1000
Site altitude above sea level		m	100	100	100	100

POWER-RELATED DATA (performance refers to net brake power as per ISO 3046)

Number of cylinders			16	16	16	16
Rated engine speed	A	rpm	1500	1800	1500	1800
Continuous power ISO 3046 (10% overload capability) (design power DIN 6280, ISO 8528)	A	kW	1798	2020	1965	2280

GENERAL CONDITIONS (for maximum power)

Number of cylinders			16	16	16	16
Intake air depression (new filter)	A	mbar	15	15	15	15
Intake air depression, max.	L	mbar	50	50	50	50
Exhaust pressure	A	mbar	30	30	30	30
Exhaust pressure, max.	L	mbar	85	85	85	85

MODEL RELATED DATA (basic design)

Number of cylinders			16	16	16	16
Engine with exhaust turbocharging (ETC) and charge air cooling (CAC)			X	X	X	X
Exhaust piping, non-cooled			X	X	X	X
Working method: four-cycle, diesel, single-acting			X	X	X	X
Combustion method: Direct fuel injection			X	X	X	X
Cooling system: conditioned water			X	X	X	X
Direction of rotation: c.c.w. (facing driving end)			X	X	X	X
Number of cylinders			16	16	16	16
Cylinder arrangement: V angle		Degrees	90	90	90	90
Bore		mm	170	170	170	170
Stroke		mm	210	210	210	210
Displacement per cylinder		liters	4.77	4.77	4.77	4.77
Total displacement		liters	76.3	76.3	76.3	76.3
Compression ratio			16.5	16.5	16.5	16.5
Cylinder heads: single-cylinder			X	X	X	X
Cylinder liners: Wet, replaceable			X	X	X	X
Inlet valves per cylinder			2	2	2	2
Exhaust valves per cylinder			2	2	2	2
Standard flywheel housing flange (engine main PTO)		SAE	00	00	00	00
Flywheel interface		DISC	21	21	21	21

COMBUSTION AIR / EXHAUST GAS

Number of cylinders			16	16	16	16
Charge air pressure before cylinder - DL	R	bar abs	2.6	2.9	2.8	3.1

COOLANT SYSTEM (HT circuit)

Number of cylinders			16	16	16	16
Coolant temperature (at engine connection: outlet to cooling equipment)	A	°C	100	100	100	100
Coolant temperature after engine, alarm	R	°C	102	102	102	102
Coolant temperature after engine, shutdown	L	°C	104	104	104	104
Coolant antifreeze content, max.	L	%	50	50	50	50
Pressure loss in off-engine cooling system, max.	L	bar	0.7	0.7	0.7	0.7

COOLING SYSTEM (LT circuit)

Number of cylinders			16	16	16	16
Coolant temperature before intercooler (at engine inlet from cooling equipment)	A	°C	55	55	55	55
Coolant antifreeze content, max.	L	%	50	50	50	50
Pressure loss in off-engine cooling system, max.	L	bar	0.7	0.7	0.7	0.7

LUBE-OIL SYSTEM

Number of cylinders			16	16	16	16
Lube oil operating temperature before engine, from	R	°C	89	90	89	88
Lube-oil operating temperature before engine, to	R	°C	95	96	95	95
Lube oil temperature before engine, alarm	R	°C	97	97	97	97
Lube oil temperature before engine, shutdown	L	°C	99	99	99	99
Lube oil operating pressure before engine, from	R	bar	4.2	4.7	4.2	4.7
Lube oil operating pressure before engine, to	R	bar	5.5	6.5	5.5	6.5
Lube oil pressure before engine, alarm	R	bar	--	--	--	--
Lube oil pressure before engine, shutdown	L	bar	--	--	--	--

FUEL SYSTEM

Number of cylinders			16	16	16	16
Fuel pressure at engine supply connection, min. (when engine is starting)	L	bar	-0.1	-0.1	-0.1	-0.1
Fuel pressure at engine supply connection, max. (when engine is starting)	L	bar	1.5	1.5	1.5	1.5

GENERAL OPERATING DATA

Number of cylinders			16	16	16	16
Cold start capability: Air temperature (w/o start aid, w/o preheating) - (case A)	R	°C	10	10	10	10
Coolant preheating, preheating temperature (min.)	R	°C	32	32	32	32
Firing speed, from	R	rpm	80	80	80	80
Firing speed, to	R	rpm	120	120	120	120

CAPACITIES

Number of cylinders			16	16	16	16
Engine coolant capacity, engine side (without cooling equipment)	R	liters	260	260	260	260
Charge-air coolant, engine side	R	liters	50	50	50	50
Total engine oil capacity at initial filling (standard oil system) (Option: max. operating inclinations)	R	liters	300	300	300	300
Oil change quantity, max. (standard oil system) (Option: max. operating inclinations)	R	liters	240	240	240	240
Oil pan capacity at dipstick mark "min." (standard oil system) (Option: max. operating inclinations)	L	liters	210	210	210	210
Oil pan capacity at dipstick mark "max." (standard oil system) (Option: max. operating inclinations)	L	liters	240	240	240	240

WEIGHTS / MAIN DIMENSIONS

Number of cylinders			16	16	16	16
Engine weight, dry (basic engine configuration acc. to scope of supply specification)	R	kg	7700	7700	7700	7700

ACOUSTICS

Number of cylinders			16	16	16	16
Exhaust noise, unsilenced - DL (sound power level LW, ISO 6798)	R	dB(A)	125	127	126	129
Engine surface noise with attenuated intake noise (filter), DL (sound power level LW, ISO 6798)	R	dB(A)	126	125	128	125

2.6.6 12/16 V 4000 Gx3 engine data: Continuous operation, variable 3B, optimized exhaust emission (EPA stage 2)

Explanation:

DL Ref. value: Continuous power

BL Ref. value: Fuel stop power

A Design value

G Guaranteed value

R Guideline value

L Limit value, up to which the engine can be operated, without change (e.g. of power settings).

N Not yet defined value

- Not applicable

X Applicable

REFERENCE CONDITIONS

Engine model			12V 4000 G43	12V 4000 G83	16 V 4000 G43	16 V 4000 G83
Application group			3B	3B	3B	3B
Intake air temperature		°C	25	25	25	25
Charge-air coolant temperature		°C	45	45	45	45
Raw water inlet temperature		°C	-	-	-	-
Barometric pressure		mbar	1000	1000	1000	1000
Site altitude above sea level		m	100	100	100	100

POWER-RELATED DATA (performance refers to net brake power as per ISO 3046)

Number of cylinders			12	12	16	16
Rated engine speed	A	rpm	1800	1800	1800	1800
Continuous power ISO 3046 (10% overload capability) (design power DIN 6280, ISO 8528)	A	kW	1520	1736	2020	2280

GENERAL CONDITIONS (for maximum power)

Number of cylinders			12	12	16	16
Intake air depression (new filter)	A	mbar	15	15	15	15
Intake air depression, max.	L	mbar	50	50	50	50
Exhaust pressure	A	mbar	30	30	30	30
Exhaust pressure, max.	L	mbar	85	85	85	85

MODEL RELATED DATA (basic design)

Number of cylinders			12	12	16	16
Engine with exhaust turbocharging (ETC) and charge air cooling (CAC)			X	X	X	X
Exhaust piping, non-cooled			X	X	X	X
Working method: four-cycle, diesel, single-acting			X	X	X	X
Combustion method: Direct fuel injection			X	X	X	X
Cooling system: conditioned water			X	X	X	X
Direction of rotation: c.c.w. (facing driving end)			X	X	X	X
Number of cylinders			12	12	16	16
Cylinder arrangement: V angle		Degrees	90	90	90	90
Bore		mm	170	170	170	170
Stroke		mm	210	210	210	210
Displacement per cylinder		liters	4.77	4.77	4.77	4.77
Total displacement		liters	57.2	57.2	76.3	76.3
Compression ratio			16.5	16.5	16.5	16.5
Cylinder heads: single-cylinder			X	X	X	X
Cylinder liners: Wet, replaceable			X	X	X	X
Inlet valves per cylinder			2	2	2	2
Exhaust valves per cylinder			2	2	2	2
Standard flywheel housing flange (engine main PTO)		SAE	00	00	00	00
Flywheel interface		DISC	21	21	21	21

COMBUSTION AIR / EXHAUST GAS

Number of cylinders			12	12	16	16
Charge air pressure before cylinder - DL	R	bar abs	3.0	3.1	3.0	3.2

COOLANT SYSTEM (HT circuit)

Number of cylinders			12	12	16	16
Coolant temperature (at engine connection: outlet to cooling equipment)	A	°C	100	100	100	100
Coolant temperature after engine, alarm	R	°C	102	102	102	102
Coolant temperature after engine, shutdown	L	°C	104	104	104	104
Coolant antifreeze content, max.	L	%	50	50	50	50
Pressure loss in off-engine cooling system, max.	L	bar	0.7	0.7	0.7	0.7

COOLING SYSTEM (LT circuit)

Number of cylinders			12	12	16	16
Coolant temperature before intercooler (at engine inlet from cooling equipment)	A	°C	45	45	45	45
Coolant antifreeze content, max.	L	%	50	50	50	50
Pressure loss in off-engine cooling system, max.	L	bar	0.7	0.7	0.7	0.7

LUBE-OIL SYSTEM

Number of cylinders			12	12	16	16
Lube oil operating temperature before engine, from	R	°C	88	88	90	88
Lube-oil operating temperature before engine, to	R	°C	98	98	96	94
Lube oil temperature before engine, alarm	R	°C	99	99	97	97
Lube oil temperature before engine, shutdown	L	°C	101	101	99	99
Lube oil operating pressure before engine, from	R	bar	5.0	5.0	4.7	4.7
Lube oil operating pressure before engine, to	R	bar	7.0	7.0	6.5	6.5
Lube oil pressure before engine, alarm	R	bar	--	--	--	--
Lube oil pressure before engine, shutdown	L	bar	--	--	--	--

FUEL SYSTEM

Number of cylinders			12	12	16	16
Fuel pressure at engine supply connection, min. (when engine is starting)	L	bar	-0.1	-0.1	-0.1	-0.1
Fuel pressure at engine supply connection, max. (when engine is starting)	L	bar	1.5	1.5	1.5	1.5

GENERAL OPERATING DATA

Number of cylinders			12	12	16	16
Cold start capability: Air temperature (w/o start aid, w/o preheating) - (case A)	R	°C	10	10	10	10
Coolant preheating, preheating temperature (min.)	R	°C	32	32	32	32
Firing speed, from	R	rpm	80	80	80	80
Firing speed, to	R	rpm	120	120	120	120

CAPACITIES

Number of cylinders			12	12	16	16
Engine coolant capacity, engine side (without cooling equipment)	R	liters	160	160	260	260
Charge-air coolant, engine side	R	liters	40	40	50	50
Total engine oil capacity at initial filling (standard oil system) (Option: max. operating inclinations)	R	liters	260	260	300	300
Oil change quantity, max. (standard oil system) (Option: max. operating inclinations)	R	liters			240	240
Oil pan capacity at dipstick mark "min." (standard oil system) (Option: max. operating inclinations)	L	liters	160	160	210	210
Oil pan capacity at dipstick mark "max." (standard oil system) (Option: max. operating inclinations)	L	liters	200	200	240	240

WEIGHTS / MAIN DIMENSIONS

Number of cylinders			12	12	16	16
Engine weight, dry (basic engine configuration acc. to scope of supply specification)	R	kg	6200*	6200*	7700	7700

ACOUSTICS

Number of cylinders			12	12	16	16
Exhaust noise, unsilenced - DL (sound power level LW, ISO 6798)	R	dB(A)	125	127	127	129
Engine surface noise with attenuated intake noise (filter), DL (sound power level LW, ISO 6798)	R	dB(A)	122	123	125	125

2.6.7 12V 4000 Gx3 engine data: Continuous operation, variable 3B, optimized exhaust emissions (TA-Luft)

Explanation:

DL Ref. value: Continuous power

BL Ref. value: Fuel stop power

A Design value

G Guaranteed value

R Guideline value

L Limit value, up to which the engine can be operated, without change (e.g. of power settings).

N Not yet defined value

- Not applicable

X Applicable

REFERENCE CONDITIONS

Engine model			12V 4000 G23	12V 4000 G63
Application group			3B	3B
Intake air temperature		°C	25	25
Charge-air coolant temperature		°C	55	55
Raw water inlet temperature		°C	-	-
Barometric pressure		mbar	1000	1000
Site altitude above sea level		m	100	100

POWER-RELATED DATA (performance refers to net brake power as per ISO 3046)

Number of cylinders			12	12
Rated engine speed	A	rpm	1500	1500
Continuous power ISO 3046 (10% overload capability) (design power DIN 6280, ISO 8528)	A	kW	1420	1575

GENERAL CONDITIONS (for maximum power)

Number of cylinders			12	12
Intake air depression (new filter)	A	mbar	15	15
Intake air depression, max.	L	mbar	50	50
Exhaust pressure	A	mbar	30	30
Exhaust pressure, max.	L	mbar	85	85

MODEL RELATED DATA (basic design)

Number of cylinders			12	12
Engine with exhaust turbocharging (ETC) and charge air cooling (CAC)			X	X
Exhaust piping, non-cooled			X	X
Working method: four-cycle, diesel, single-acting			X	X
Combustion method: Direct fuel injection			X	X
Cooling system: conditioned water			X	X
Direction of rotation: c.c.w. (facing driving end)			X	X
Number of cylinders			12	12
Cylinder arrangement: V angle		Degrees	90	90
Bore		mm	170	170
Stroke		mm	210	210
Displacement per cylinder		liters	4.77	4.77
Total displacement		liters	57.2	57.2
Compression ratio			16.5	16.5
Cylinder heads: single-cylinder			X	X
Cylinder liners: Wet, replaceable			X	X
Inlet valves per cylinder			2	2
Exhaust valves per cylinder			2	2
Standard flywheel housing flange (engine main PTO)		SAE	00	00
Flywheel interface		DISC	21	21

COMBUSTION AIR / EXHAUST GAS

Number of cylinders			12	12
Charge air pressure before cylinder - DL	R	bar abs	3.2	3.5

COOLANT SYSTEM (HT circuit)

Number of cylinders			12	12
Coolant temperature (at engine connection: outlet to cooling equipment)	A	°C	100	100
Coolant temperature after engine, alarm	R	°C	102	102
Coolant temperature after engine, shutdown	L	°C	104	104
Coolant antifreeze content, max.	L	%	50	50
Pressure loss in off-engine cooling system, max.	L	bar	0.7	0.7

COOLING SYSTEM (LT circuit)

Number of cylinders			12	12
Coolant temperature before intercooler (at engine inlet from cooling equipment)	A	°C	55	55
Coolant antifreeze content, max.	L	%	50	50
Pressure loss in off-engine cooling system, max.	L	bar	0.7	0.7

LUBE-OIL SYSTEM

Number of cylinders			12	12
Lube oil operating temperature before engine, from	R	°C	88	88
Lube-oil operating temperature before engine, to	R	°C	98	98
Lube oil temperature before engine, alarm	R	°C	99	99
Lube oil temperature before engine, shutdown	L	°C	101	101
Lube oil operating pressure before engine, from	R	bar	5.0	5.0
Lube oil operating pressure before engine, to	R	bar	7.0	7.0
Lube oil pressure before engine, alarm	R	bar	--	--
Lube oil pressure before engine, shutdown	L	bar	--	--

FUEL SYSTEM

Number of cylinders			12	12
Fuel pressure at engine supply connection, min. (when engine is starting)	L	bar	-0.1	-0.1
Fuel pressure at engine supply connection, max. (when engine is starting)	L	bar	1.5	1.5

GENERAL OPERATING DATA

Number of cylinders			12	12
Cold start capability: Air temperature (w/o start aid, w/o preheating) - (case A)	R	°C	10	10
Coolant preheating, preheating temperature (min.)	R	°C	32	32
Firing speed, from	R	rpm	80	80
Firing speed, to	R	rpm	120	120

CAPACITIES

Number of cylinders			12	12
Engine coolant capacity, engine side (without cooling equipment)	R	liters	160	160
Charge-air coolant, engine side	R	liters	40	40
Total engine oil capacity at initial filling (standard oil system) (Option: max. operating inclinations)	R	liters	260	260
Oil change quantity, max. (standard oil system) (Option: max. operating inclinations)	R	liters		
Oil pan capacity at dipstick mark "min." (standard oil system) (Option: max. operating inclinations)	L	liters	160	160
Oil pan capacity at dipstick mark "max." (standard oil system) (Option: max. operating inclinations)	L	liters	200	200

WEIGHTS / MAIN DIMENSIONS

Number of cylinders			12	12
Engine weight, dry (basic engine configuration acc. to scope of supply specification)	R	kg	6200*	6200*

ACOUSTICS

Number of cylinders			12	12
Exhaust noise, unsilenced - DL (sound power level LW, ISO 6798)	R	dB(A)	126	127
Engine surface noise with attenuated intake noise (filter), DL (sound power level LW, ISO 6798)	R	dB(A)	122	122

3 Operation

3.1 Putting the engine into operation after extended out-of-service-periods (>3 months)

Preconditions

- Engine is stopped and starting disabled.
- MTU Fluids and Lubricants Specifications (A001061/..) are available.

Putting the engine into operation after extended out-of-service-periods (>3 months)

Item	Task
Engine	Depreserve (→MTU Fluids and Lubricants Specifications A001061/..).
Valve gear	Lubricate valve gear every ≥ 6 months (→ Page 104).
Lube oil system	Check engine oil level (→ Page 134).
Fuel prefilter	Prime (→ Page 122).
Fuel prefilter, pressure gauge	Align adjustable pointer with position of pressure indicator (→ Page 117).
Coolant circuit	If engine is out of service for more than one year, change engine coolant (→ Page 139); Change charge-air coolant (→ Page 146).
Coolant circuit	Check engine coolant level (→ Page 143); Check charge-air coolant level (→ Page 150).
Coolant circuit	Preheat coolant with preheating unit.
ECU	Check plug-in connections (→ Page 157).
Monitoring equipment	Carry out lamp test (see manufacturer's documentation).
Engine/generator control system	Switch ON; Select operating mode, e.g. MANUAL OPERATION, AUTOMATIC OPERATION.

3.2 Putting the engine into operation after scheduled out-of-service-period

Preconditions

- Engine is stopped and starting disabled.

Putting the engine into operation

Item	Task
Lube oil system	Check oil level (→ Page 134);
Cooling system	Check engine coolant level (→ Page 143); Check charge-air coolant level (→ Page 150).
Cooling system	Preheat coolant with preheating unit.
Fuel prefilter	Drain (→ Page 118).
Monitoring equipment	Carry out lamp test (see manufacturer's documentation).
Engine/generator control system	Switch ON; Select operating mode, e.g. MANUAL OPERATION, AUTOMATIC OPERATION.

3.3 Starting the engine in manual mode

Preconditions

- Generator is not connected to network.
- External start interlock is not activated.

 DANGER	Unguarded rotating and moving engine components. Risk of serious injury — danger to life! <ul style="list-style-type: none"> • Before barring or starting the engine, ensure that nobody is in the danger zone.
--	--

 WARNING	Engine noise above 85 dB (A). Risk of damage to hearing! <ul style="list-style-type: none"> • Wear ear protectors.
---	---

Preparation

Item	Task
Operating mode selector switch (if provided)	Change to manual mode.
Preheating pump (if provided)	Switch ON.

Starting the engine

Item	Task
Switching cabinet, control panel etc. (depending on manufacturer)	If coolant temperature is <ul style="list-style-type: none"> • > 40 °C (with preheating pump), or • > 10 °C (60 Hz generator, without preheating pump), or • > 5 °C (50 Hz generator, without preheating pump): Press start button. <ul style="list-style-type: none"> • Automatic starting procedure is performed; • Tachometer indicates increasing crankshaft speed; • After the starting procedure is completed, engine is running at rated speed.

Connecting the generator to network, running the engine to reach operating temperature

Item	Task
Switching cabinet, control panel etc. (depending on manufacturer)	Close the generator circuit breaker.
Engine	Run engine at 10 to 15 % of rated power to reach operating temperature. Apply full load only after engine has reached operating temperature (coolant temperature approx. 75 °C).

3.4 Emergency start (override mode)



Safety functions and engine shutdown alarms will be disregarded.
Serious damage to plant!

- Initiate emergency start only in emergency situations.

Preparation

Item	Task
Operating mode selector switch (if provided)	Change to manual mode.



Emergency start

Item	Task
Switching cabinet, control panel etc. (depending on manufacturer)	Actuate switch/button for override input of ECU.
Switching cabinet, control panel etc. (depending on manufacturer)	Press start button. <ul style="list-style-type: none"> • Automatic starting procedure is performed; All safety functions are deactivated and engine shutdown alarms disregarded; • Tachometer indicates increasing crankshaft speed; • After the starting procedure is completed, engine is running at rated speed.

Connecting the generator to network

Item	Task
Switching cabinet, control panel etc. (depending on manufacturer)	If generator is not connected to network: Close the generator circuit breaker.
Engine	Run at rated power.

3.5 Operational checks

 DANGER	Unguarded rotating and moving engine components. Risk of serious injury – danger to life! <ul style="list-style-type: none"> • Take special care when working on a running engine.
 WARNING	Engine noise above 85 dB (A). Risk of damage to hearing! <ul style="list-style-type: none"> • Wear ear protectors.

Operational checks

Item	Task
Control and display panels	Check displayed operational data (speed, temperature, pressures).
Engine under load, Engine at nominal speed	Check engine/system and lines for leak-tightness, perform maintenance work on lines showing leakage while motor is turned off (exhaust manifolds and turbocharger turbine housing may be glowing with heat. If maximum exhaust temperatures are within the limit, restricted engine operation is not required); Check for abnormal running noises and vibration.
Fuel prefilter	Check if suction-side pressure indicated at the fuel prefilter pressure gauge is within the limit (→ Page 117).
Exhaust system	Check exhaust color (→ Page 71).
Intercooler	Check drain for coolant discharge and obstruction (→ Page 124).
Air filters	Check signal ring position of service indicator (→ Page 129); Replace air filter (→ Page 125), if the signal ring is completely visible in the service indicator control window.
Engine coolant pump	Check relief bore (→ Page 144).
Charge-air coolant pump	Check relief bore (→ Page 151).
Compressed-air system (if applicable)	Check operating pressure on pressure gauge; Always fill compressed-air tank to max. pressure; Drain condensate from compressed-air tank, pressure drop must not exceed 1 bar.

3.6 Stopping the engine in manual mode

Preconditions

- Generator is not connected to network.
- Engine is running in manual mode.



Stopping the engine when it is running at full load causes extreme stress to the engine.

Risk of overheating, damage to components!

- Before stopping the engine, operate it at idle speed until operating temperatures decrease and stable values are indicated.

Preparation

Item	Task
Engine	After the generator circuit breaker has been opened, allow the engine to cool down by running it idle for approx. 5 minutes.

Stopping the engine

Item	Task
Switching cabinet, control panel etc. (depending on manufacturer)	Press stop button. <ul style="list-style-type: none"> • Automatic stopping procedure is performed; • Engine is stopped.

After stopping the engine

Item	Task
Cooling pump	Operate for approx. 5 minutes after engine stop.

3.7 Emergency stop



An emergency stop causes extreme stress to the engine.
Risk of overheating, damage to components!

- Initiate emergency stop only in emergency situations.

Emergency stop from LOP

Item	Task
EMERGENCY STOP button	Press. <ul style="list-style-type: none"> • Engine is stopped by switching off power supply to ECU; • Signalization (e.g. by horn, flashing lamp) is released.

After emergency stop from LOP

Item	Task
Switching cabinet, control panel etc. (depending on manufacturer)	Press button for alarm acknowledgement. <ul style="list-style-type: none"> • Audible and visual signalization stops.

3.8 After stopping the engine – engine remains ready for operation

After stopping the engine

Item	Task
Engine/generator control system	Select operating mode, e.g. MANUAL OPERATION, AUTOMATIC OPERATION.

3.9 After stopping the engine – putting the engine out of service

Preconditions

- MTU Fluids and Lubricants Specification (A001061/..) is available.

After stopping the engine

Item	Task
Cooling system	Drain engine coolant (→ Page 142); Drain charge-air coolant (→ Page 149) if: <ul style="list-style-type: none"> • freezing temperatures are expected and the engine is to remain out of service for an extended period and coolant has no antifreeze additive; • the engine room is not heated; • the coolant is not maintained at a suitable temperature; • the antifreeze concentration is insufficient for the engine-room temperature; • antifreeze concentration is 50% and engine-room temperature is below -40°C.
Engine/generator control system	Switch OFF.
Air intake and exhaust system	If the engine is to remain out of service for more than 1 week, seal the engine's air and exhaust sides. If the engine is to remain out of service for more than 1 month, carry out preservation (→MTU Fluids and Lubricants Specification A001061/..).

4 Maintenance

4.1 Preface

MTU maintenance concept

The maintenance system for MTU products is based on a preventive maintenance concept. Preventive maintenance facilitates advance planning and ensures a high level of equipment availability.

The maintenance schedule is based on the load profile / load factor specified below. The time intervals at which the maintenance work is to be carried out and the relevant checks and tasks involved are average values based on operational experience and are therefore to be regarded as guidelines only. Special operating conditions and technical requirements may require additional maintenance work and/or modifications of the maintenance intervals. Maintenance personnel charged with carrying out maintenance work must be appropriately qualified depending on the complexity of the task concerned. The various Qualification Levels QL1 to QL4 reflect the levels of training offered in MTU courses and the contents of the tool kits required:

QL1: Operational monitoring and maintenance which can be carried out during a break in operation without disassembling the engine.

QL2: Exchange of components (corrective only).

QL3: Maintenance work which requires partial disassembly of the engine.

QL4: Maintenance work which requires complete disassembly of the engine.

The maintenance schedule matrix normally finishes with extended component maintenance. Following this, maintenance work is to be continued at the intervals indicated.

The "Task" numbers stated in the list of jobs to be done/action to be taken indicate the relevant maintenance item. They serve as a reference for the scope of parts needed and also appear on the labels of the corresponding spare parts.

Preventive maintenance instructions

Specifications for fluids and lubricants, guideline values for their maintenance and change intervals and lists of recommended fluids and lubricants are contained in the MTU Fluids and Lubricants Specifications A001061 and in the fluids and lubricants specifications produced by the component manufacturers. They are therefore not listed in the maintenance schedule (exception: deviations from the Fluids and Lubricants Specifications). Only use fluids and lubricants which meet MTU specifications or are approved by the component manufacturer concerned.

Amongst other items, the operator/customer must perform the following additional maintenance work:

- Protect components made of rubber or synthetic material from oil. Never treat them with organic detergents. Wipe with a dry cloth only.
- Fuel prefilter:
The maintenance interval depends on how dirty the fuel is. The paper inserts in fuel prefilters must be replaced every 2 years at the latest (Task 9998).
- Battery:
Battery maintenance depends on use and ambient conditions. The battery manufacturer's instructions must be obeyed.

The relevant manufacturer's instructions apply with respect to the maintenance of any components which do not appear in this maintenance schedule.

Items that are listed in this maintenance schedule but that do not refer to the respective engine model, can be ignored.

Out-of-service periods

If the engine is to remain out of service for more than 1 month, carry out engine preservation procedures in accordance with the MTU Fluids and Lubricants Specifications, Publication No. A001061/.

Application group

3B	Continuous operation, variable
3D	Standby operation

4.2 Maintenance schedule matrix

Maintenance schedule matrix for application group 3B, 0-10,000 operating hours

Item	Limit years	Operating hours [hrs]																						
		Daily	500	1,000	1,500	2,000	2,500	3,000	3,500	4,000	4,500	5,000	5,500	6,000	6,500	7,000	7,500	8,000	8,500	9,000	9,500	10,000		
Engine oil filter	2																							
Engine operation	-	X																						
Centrifugal oil filter	2		X	X	X	X	X	X	X	X	X	X	X	X	X	X	X	X	X	X	X	X	X	X
Valve gear	-			X		X		X		X		X		X		X		X		X		X		
Fuel filter	2			X		X		X		X		X		X		X		X		X		X		
Belt drive	2				X			X		X			X			X				X				
Air filter	3							X					X							X				
Fuel injector	-											X											X	
Cylinder chambers	4											X											X	
Rubber sleeves	5											X											X	
Crankcase breather	-																						X	
Exhaust turbocharger	-																						X	
Component maintenance	-																						X	
Fuel delivery pump	-																						X	
Cylinder head	-																						X	
Extended component maintenance	18																						X	

Maintenance schedule matrix for application group 3C, 0-6,000 operating hours

Item	Limit years	Operating hours [hrs]																			
		Daily	500	1,000	1,500	2,000	2,500	3,000	3,500	4,000	4,500	5,000	5,500	6,000							
Engine oil filter	2																				
Engine operation	-	X																			
Centrifugal oil filter	2		X	X	X	X	X	X	X	X	X	X	X	X							
Valve gear	-			X		X		X		X		X		X							
Fuel filter	2			X		X		X		X		X		X							
Belt drive	2			X		X		X		X		X		X							
Air filter	3							X												X	
Rubber sleeves	6							X												X	
Fuel injector	-																			X	
Cylinder chambers	4																			X	
Crankcase breather	-																			X	
Exhaust turbocharger	-																			X	
Component maintenance	-																			X	
Cylinder head	-																			X	
Extended component maintenance	18																			X	

4.3 Maintenance tasks

Qualification	Interval		Item	Maintenance tasks	Task
	[h]	[a]			
QL1			Engine oil filter	Replace oil filter when changing engine oil, or when the interval (years) is reached, at the latest (→ Page 136).	W1008
QL1			Engine operation	Check engine oil level (→ Page 59). Check engine visually for leaks and general condition (→ Page 59). Check intercooler drain (if fitted) (→ Page 59). Check signal ring position of service indicator (→ Page 59). Check water pump(s) relief bores (→ Page 59). Check for abnormal running noise, exhaust gas color and vibrations (→ Page 59). Drain water and contaminants from fuel prefilter (if fitted) (→ Page 59). Check reading on differential pressure gauge of fuel prefilter (if fitted) (→ Page 59).	W0500 W0501 W0502 W0503 W0505 W0506 W0507 W0508
QL1			Centrifugal oil filter	Centrifugal oil filter (if fitted): Check layer thickness of the oil residue, clean out and replace filter sleeve (→ Page 137).	W1009
QL1			Fuel filter	Replace fuel filter or fuel filter element (→ Page 115).	W1001
QL1			Valve gear	Check valve clearance (→ Page 105).	W1002
QL1			Belt drive	Check drive belt condition and tension, replace if necessary (→ Page 152); adjust belt tension (→ Page 153).	W1241
QL1			Air filter	Replace air filter (→ Page 125).	W1005
QL1			Fuel injector	Replace fuel injectors (→ Page 109).	W1006
QL1			Cylinder chambers	Perform endoscopic examination (→ Page 98).	W1011
QL1			Rubber sleeves	Replace all rubber sleeves (→ Page 128) and DM125150921A.	W1250
QL1			Crankcase breather	Crankcase breather: Replace filter or filter element (→ Page 102).	W1046
QL3			Exhaust turbocharger	Replace exhaust turbocharger (→Maintenance Manual).	W1041
QL3			Component maintenance	Prior to maintenance work, drain coolant and flush coolant circuits. Check rocker arms and valve bridge for wear (→Maintenance Manual) visually inspect swing followers and camshaft running faces with endoscope through pushrod bore (→Maintenance Manual). Clean air system (→Maintenance Manual). Clean intercooler and check for leaks (→Maintenance Manual). Replace fuel HP sensor (→Maintenance Manual). Check engine coolant thermostat and replace thermostat insert (→Maintenance Manual). Check charge-air coolant thermostat and replace thermostat insert (→Maintenance Manual). Overhaul engine coolant preheating (if fitted) (→Maintenance Manual). Check centrifugal oil filter for wear (if fitted) (→ Maintenance Manual).	W2000 W2001 W2002 W2003 W2004 W2006 W2007 W2008 W2009

Qualification	Interval		Item	Maintenance tasks	Task
	[h]	[a]			
				Overhaul starter (→Maintenance Manual). Overhaul charge-air coolant pump (→Maintenance Manual). Replace sealing materials of all disassembled components. Overhaul engine coolant pump (→Maintenance Manual).	W2010 W2070 W2062 W2110
QL3			Fuel delivery pump	Replace fuel delivery pump (→Maintenance Manual).	W1051
QL3			Cylinder head	Overhaul cylinder heads (→Maintenance Manual).	W1134
QL4			Extended component maintenance	Disassemble engine completely. Inspect engine components acc. to assembly Instructions; repair or replace as necessary (→Workshop Manual). Replace all elastomer parts and seals. Replace piston rings (→Workshop Manual). Replace conrod bearings (→Workshop Manual). Replace crankshaft bearings (→Workshop Manual). Replace cylinder liners (→Workshop Manual). Replace auxiliary PTO antifricition bearing (→Workshop Manual). Replace high-pressure fuel pump (→Workshop Manual). Overhaul battery-charging generator (→Workshop Manual).	W3000 W3001 W3002 W3003 W3004 W3005 W3006 W3007 W3042

5 Troubleshooting

5.1 Troubleshooting

Engine does not turn when starter is actuated

Component	Probable Cause	Task
Battery	Low or defective	Charge or replace (see manufacturer's documentation).
	Cable connections defective	Check if cable connections are properly secured (see manufacturer's documentation).
Starter	Engine wiring or starter defective	Check if cable connections are properly secured, contact Service.
Engine wiring	Defective	Check (→ Page 155).
Engine/generator control system	Secure seating of assemblies or connectors not provided	Perform visual inspection (see manufacturer's documentation).
ECU	Plug-in connections are loose	Check plug-in connections (→ Page 157).
Engine	Running gear blocked (engine cannot be barred manually)	Contact Service.

Engine turns but does not fire

Component	Probable Cause	Task
Starter	Poor rotation by starter: Battery low or defective	Charge or replace battery (see manufacturer's documentation).
Engine wiring	Defective	Check (→ Page 155).
Fuel system	Not vented	Vent fuel system (→ Page 114).
ECU	Defective	Contact Service.

Engine fires unevenly

Component	Probable Cause	Task
Fuel injection equipment	Injector defective	Replace (→ Page 109).
Engine wiring	Defective	Check (→ Page 155).
Fuel system	Not vented	Vent fuel system (→ Page 114).
ECU	Defective	Contact Service.

Engine does not reach nominal speed

Component	Probable Cause	Task
Fuel supply	Fuel prefilter clogged	Replace (→ Page 122).
	Fuel filter clogged	Replace (→ Page 115).
Air supply	Air filter clogged	Check signal ring position of service indicator (→ Page 129).
Fuel injection equipment	Injector defective	Replace (→ Page 109).
Engine wiring	Defective	Check (→ Page 155).
Engine	Overloaded	Contact Service.

Engine speed not steady

Component	Probable Cause	Task
Fuel injection equipment	Injector defective	Replace (→ Page 109).
Speed sensor	Defective	Contact Service.
Fuel system	Not vented	Vent fuel system (→ Page 114).
ECU	Defective	Contact Service.

Charge-air temperature too high

Component	Probable Cause	Task
Engine coolant	Incorrect coolant concentration	Check (MTU test kit).
Intercooler	Contaminated	Contact Service.
Engine room	Air-intake temperature too high	Check fans and air supply / ventilation ducts.

Charge air pressure too low

Component	Probable Cause	Task
Air supply	Air filter clogged	Check signal ring position of service indicator (→ Page 129).
Intercooler	Contaminated	Contact Service.
Exhaust turbocharger	Defective	Contact Service.

Coolant leaks on intercooler

Component	Probable Cause	Task
Intercooler	Leaking, major coolant discharge	Contact Service.

Exhaust gas black

Component	Probable Cause	Task
Air supply	Air filter clogged	Check signal ring position of service indicator (→ Page 129).
Fuel injection equipment	Injector defective	Replace (→ Page 109).
Engine	Overloaded	Contact Service.

Exhaust gas blue

Component	Probable Cause	Task
Engine oil	Too much oil in engine	Drain engine oil (→ Page 132).
	Oil separator of crankcase breather contaminated	Replace (→ Page 102).
Exhaust turbocharger, cylinder head, piston rings, cylinder liner	Defective	Contact Service.

Exhaust gas white

Component	Probable Cause	Task
Engine	Not at operating temperature	Run engine to reach operating temperature.
Fuel system	Water in fuel	Check fuel system on fuel prefilter. Drain fuel prefilter (→ Page 118).
Intercooler	Leaking	Contact Service.

5.2 Engine governor ADEC (ECU 7) for Series 4000 genset engines - Fault messages

The fault code numbers are generated by the Engine Control Unit and transmitted to the following display.

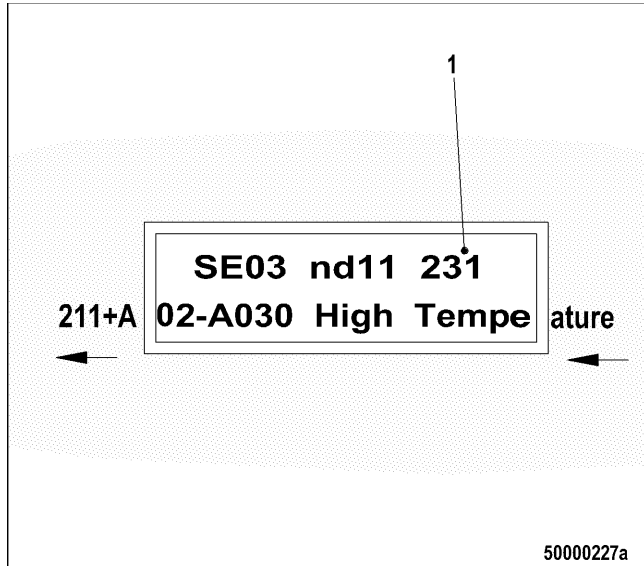

The fault code (1) comprises 3 digits.

Fault messages may also be caused by faulty sensors/actuators. Contact Service to have sensors/actuators tested and replaced as necessary if troubleshooting as described in the table below proves unsuccessful.

The table below lists possible fault codes:

Fault code No.	Designation	Meaning	Task	Related parameter No.
003	HI T-Fuel	Preliminary warning: Fuel temperature too high.	Contact Service.	2.0122.931
004	SS T-Fuel	Main warning: Fuel temperature too high; Engine stop.	Contact Service.	2.0122.932
005	HI T-Charge Air	Preliminary warning: Charge-air temperature too high	1. Reduce power. 2. Check intercooler.	2.0121.931
006	SS T-Charge Air	Main warning: Charge-air temperature too high; Engine stop.	1. Reduce power. 2. Check intercooler.	2.0121.932
009	AL L1 T-Coolant Intercooler	Preliminary warning: Coolant pressure in intercooler too low.	Reduce power.	2.0124.931
010	AL L2 T-Coolant Intercooler	Main warning: Charge-air coolant temperature too high; Engine stop.	Reduce power.	2.0124.932
015	LO P-Lube Oil	Preliminary warning: Lube oil pressure too low.	Check oil level, top up as necessary (→ Page 134).	2.0100.921

Fault code No.	Designation	Meaning	Task	Related parameter No.
016	SS P-Lube Oil	Main warning: Lube oil pressure too low; Engine will be shut down.	<ol style="list-style-type: none"> 1. Check oil level, top up as necessary (→ Page 134). 2. Attempt to restart engine (→ Page 57). 	2.0100.922
019	HI T-Exhaust A	Preliminary warning: Exhaust temperature (A-side) too high.	<ol style="list-style-type: none"> 1. Check cabling (→ Page 155). 2. Contact Service. 	2.0126.931
020	SS T-Exhaust A	Main warning: Exhaust temperature (A-side) too high. Engine stop.	<ol style="list-style-type: none"> 1. Check cabling (→ Page 155). 2. Contact Service. 	2.0126.932
021	HI T-Exhaust B	Preliminary warning: Exhaust temperature (B-side) too high.	<ol style="list-style-type: none"> 1. Check cabling (→ Page 155). 2. Contact Service. 	2.0127.931
022	SS T-Exhaust B	Main warning: Exhaust temperature (B-side) too high. Engine stop.	<ol style="list-style-type: none"> 1. Check cabling (→ Page 155). 2. Contact Service. 	2.0127.932
023	LO Coolant Level	Alarm configuration limit value 1; Coolant level too low.	Check coolant level in expansion tank (→ Page 143).	2.0152.921
024	SS Coolant Level	Alarm configuration limit value 2; Coolant level too low.	Check coolant level in expansion tank (→ Page 143).	2.0152.912
025	HI P-Diff. Lube Oil	Alarm configuration limit value 1; Preliminary warning: Oil filter differential pressure too high.	Replace oil filter (→ Page 136).	2.0154.931
026	HI P-Diff. Lube Oil	Alarm configuration limit value 1; Preliminary warning: Oil filter differential pressure too high.	Replace oil filter (→ Page 136).	2.0154.932
027	HI Leak Fuel Level	Alarm configuration limit value 1; Preliminary warning: Leak-off fuel level too high.	<ol style="list-style-type: none"> 1. Check fuel system. 2. Contact Service. 	2.0151.931
029	HI ETC 2 idle speed	Idle speed of ETC 2 too high.	Contact Service.	1.8004.206
030	SS Engine Speed	Alarm configuration limit value 2; Engine overspeed; reduced fuel injection.	<ol style="list-style-type: none"> 1. Acknowledge alarm. 2. Attempt to restart engine. 	2.2510.932

Fault code No.	Designation	Meaning	Task	Related parameter No.
031	HI ETC 1 overspeed	Alarm configuration limit value 1; preliminary warning: speed of primary turbocharger too high.	Contact Service.	2.3011.931
032	SS ETC 1 overspeed	Alarm configuration limit value 2; Speed of primary turbocharger too high.	1. Automatic power reduction by engine control system. 2. Check air filters. (→ Page 126).	2.3012.932
036	HI ETC 2 overspeed	Alarm configuration limit value 1; preliminary warning: speed of secondary turbocharger too high.	1. Reduce power. 2. Contact Service.	2.3013.931
037	SS ETC 2 overspeed	Alarm configuration limit value 2; Main warning: speed of secondary turbocharger too high. Fuel limitation to a fixed value.	1. Reduce power. 2. Contact Service.	2.3013.912
038	AL ETC Synchro Fault	Synchronization error between ETCs 1 and 2.	1. Reduce power. 2. Contact Service.	1.8004.205
039	AL ETC 2 cut-in failure	ETC2 failed to cut in.	1. Reduce power. 2. Contact Service.	1.8004.204
044	L1 Coolant Level Intercooler	Alarm configuration limit value 1; Intercooler coolant level too low.	Check coolant level (→ Page 150).	2.0153.921
051	HI T-Lube Oil	Preliminary warning: Lube oil temperature too high.	Reduce power.	2.0125.931
052	SS T-Lube Oil	Main warning: Lube oil temperature too high; Engine stop.	1. Reduce power. 2. Check engine oil level (→ Page 134).	2.0125.932
057	LO P-Coolant	Preliminary warning: Coolant pressure too low.	Check coolant circuit.	2.0101.921
058	SS P-Coolant	Main warning: Coolant pressure too low; Engine stop or reduced fuel injection.	1. Automatic engine shutdown. 2. Check coolant level (→ Page 143).	2.0101.922
063	HI P-Crankcase	Preliminary warning: Crankcase pressure too high.	1. Reduce power. 2. Replace oil separator element (→ Page 102).	2.0106.931

Fault code No.	Designation	Meaning	Task	Related parameter No.
064	SS P-Crankcase	Main warning: Crankcase pressure too high; Engine stop.	<ol style="list-style-type: none"> 1. Replace oil separator element (→ Page 102). 2. Contact Service. 	2.0106.932
065	LO P-Fuel	Preliminary warning: Coolant fuel supply pressure too low.	<ol style="list-style-type: none"> 1. Check fuel lines for leaks. 2. Clean fuel prefilter (→ Page 116). 3. Flush fuel prefilter (→ Page 120). 4. Replace filter element of fuel prefilter (→ Page 122). 5. Replace fuel filter (→ Page 115). 	2.0102.921
066	SS P-Fuel	Main warning: fuel supply pressure too low; Engine stop.	<ol style="list-style-type: none"> 1. Check fuel lines for leaks. 2. Clean fuel prefilter (→ Page 116). 3. Fuel prefilter - Flushing (→ Page 120). 4. Replace filter element of fuel prefilter (→ Page 122). 5. Replace fuel filter (→ Page 115). 	2.0102.922
067	HI T-Coolant	Preliminary warning: Coolant temperature too high.	Reduce power.	2.0120.931
068	SS T-Coolant	Alarm configuration limit value 2; Main warning: Coolant temperature too high; Engine stop.	<ol style="list-style-type: none"> 1. Allow engine to cool down; 2. Check coolant cooler, clean if necessary. 3. Restart engine (→ Page 57). 4. Contact Service. 	2.0120.932
081	AL Rail Leakage	Pressure gradient in rail is too low during starting or too high during stopping; HP system leaky, air in system).	Contact Service.	1.8004.046

Fault code No.	Designation	Meaning	Task	Related parameter No.
082	HI P-Fuel (Common Rail)	Rail pressure > reference value; DBR fuel limitation, start of injection readjusted towards late; Suction restrictor of HP fuel block jamming or HP fuel control block wiring faulty.	Contact Service.	2.0104.931
083	LO P-Fuel (Common Rail)	Rail pressure <reference value; DBR fuel limitation; Suction restrictor of HP fuel control block faulty or leakage in HP fuel system.	Contact Service.	2.0104.921
085	HI T-Recirculation	Preliminary warning: Recirculation temperature too high.	Reduce power.	2.0128.931
086	HI T-Recirculation	Main warning: Recirculation temperature too high.	Reduce power.	2.0128.932
089	AL Stalling Engine	Alarm configuration limit value; Engine speed too low.	Check for additional messages.	2.2500.030
090	SS No Idling Speed	Alarm configuration limit value; Idling speed was not attained.	Contact Service.	2.1090.925
091	SS No Runup Speed	Alarm configuration limit value; Runup speed was not attained.	Contact Service.	2.1090.924
092	SS No Starter Speed	Alarm configuration limit value; Starter speed was not attained; Termination of starting sequence; Starter rotates too slowly or does not rotate at all.	Contact Service.	2.1090.923
093	SS T-Preheat	Alarm configuration limit value 2; Main warning: preheating temperature too low; coolant temperature too low for engine start; engine start interlock active.	Check preheater.	2.1090.922
094	LO T-Preheat	Alarm configuration limit value 1; Preheating temperature too low; coolant temperature too low for engine start.	Check preheater.	2.1090.921
095	AL Prelubrication Fault	Alarm configuration; Oil priming failure.	Check oil priming system.	2.1090.920
102	AL Consumption Meter Faulty	Alarm configuration; Consumption meter faulty.	Contact Service.	1.8004.624
104	AL Eng Hours Counter Defect	Alarm configuration; Hourmeter faulty.	Contact Service.	1.8004.623
118	LO ECU Supply Voltage	Alarm configuration limit value 1; Preliminary warning: Supply voltage too low.	<ol style="list-style-type: none"> 1. Check ECU supply voltage. 2. Contact Service. 	2.0140.921

Fault code No.	Designation	Meaning	Task	Related parameter No.
119	LOLO ECU Supply Voltage	Alarm configuration limit value 2; Main warning: Supply voltage too low.	1. Check ECU supply voltage. 2. Contact Service.	2.0140.922
120	HI ECU Supply Voltage	Alarm configuration limit value 1; Preliminary warning: Supply voltage too high.	1. Check ECU supply voltage. 2. Contact Service.	2.0140.931
121	HIHI ECU Supply Voltage	Alarm configuration limit value 2; Main warning: Supply voltage too high.	1. Check ECU supply voltage. 2. Contact Service.	2.0140.932
122	HI T-ECU	Alarm configuration limit value 1; Preliminary warning: Temperature in ECU too high.	1. Reduce power. 2. Improve engine room ventilation.	2.0132.921
134	15V POS ECU DEFECT	Internal voltage (-15 VDC) faulty; automatic engine shutdown.	Replace ECU.	
136	15V NEG ECU DEFECT	Internal voltage (-15 VDC) missing; automatic engine shutdown.	Contact Service.	
139	L1 TE BUFFER TEST	Supply voltage of temperature sensors faulty.	1. Check sensors. 2. Replace ECU. 3. Contact Service.	
140	TE BUF. ECU DEFECT	Supply voltage of temperature sensors faulty.	1. Check sensors. 2. Replace ECU. 3. Contact Service.	
142	BANK1 ECU DEFECT	Power output stage for control of the solenoid valves on bank 1 is faulty; Engine does not start.	Replace ECU.	
144	BANK2 ECU DEFECT	Power output stage for control of the solenoid valves on bank 2 is faulty; Engine does not start.	Replace ECU.	
145	15V_GOOD ECU DEFECT	Power supply faulty; automatic engine shutdown.	Replace ECU.	
146	L1 AD-TEST1 SUPPLY	Supply voltage A/D converter too low.	Replace ECU.	
147	AD-TEST1 ECU DEFECT	Electronic fault; automatic engine shutdown.	Replace ECU.	
148	L1 AD-TEST2 SUPPLY	Supply voltage A/D converter too low.	Replace ECU.	

Fault code No.	Designation	Meaning	Task	Related parameter No.
149	AD-TEST2 ECU DEFECT	Internal electronic fault; automatic engine shutdown.	Replace ECU.	
150	L1 AD-TEST3 SUPPLY	Internal electronic fault; automatic engine shutdown.	Replace ECU.	
151	AD-TEST3 ECU DEFECT	Internal electronic fault; automatic engine shutdown.	Replace ECU.	
176	AL LifeData Not Avail	Alarm configuration; No (appropriate) LifeData backup system available, ECU reset after expiration of time-out period.	Contact Service.	2.4000.004
177	AL LifeData restore incomplete	Alarm configuration; This error message is generated if a CRC is faulty during a data upload to ADEC (indicated for each indiv. module).	Contact Service.	2.4000.006
180	AL CAN1 Node Lost	Alarm configuration; Connection to one node on CAN bus 1 failed.	Contact Service.	2.0500.680
181	AL CAN2 Node Lost	Alarm configuration; Connection to one node on CAN bus 2 failed.	Contact Service.	2.0500.681
182	AL CAN Wrong Parameters	Alarm configuration; Incorrect parameter values entered in data record.	Contact Service.	2.0500.682
183	AL CAN No PU-Data	Alarm configuration; A CAN mode has been selected in which communication with the PU data module is initialized. However, the required PU data module is not available or not valid.	Contact Service.	2.0500.683
184	AL CAN PU-Data Flash Error	Alarm configuration; A programming error occurred when attempting to copy a received PU data module into the Flash module.	Contact Service.	2.0500.684
186	AL CAN1 Bus Off	Alarm configuration; CAN controller 1 is in "Bus-Off" status.	<ol style="list-style-type: none"> 1. Inspect CAN bus for short circuit and rectify short circuit as necessary. 2. Check shielding, improve as necessary. 3. Contact Service. 	2.0500.686

Fault code No.	Designation	Meaning	Task	Related parameter No.
187	AL CAN1 Error Passive	Alarm configuration; CAN controller 1 has signalled a warning.	<ol style="list-style-type: none"> 1. Inspect CAN bus for short circuit and rectify short circuit as necessary. 2. Check shielding, improve as necessary. 3. Contact Service. 	2.0500.687
188	AL CAN2 Bus Off	Alarm configuration; CAN controller 2 is in "Bus-Off" status. Automatic changeover to CAN 1; Short circuit, massive interference or Baud rate incompatibility.	<ol style="list-style-type: none"> 1. Inspect CAN bus for short circuit and rectify short circuit as necessary. 2. Check shielding, improve as necessary. 3. Contact Service. 	2.0500.688
189	AL CAN2 Error Passive	Alarm configuration; CAN controller 2 has signalled a warning.	<ol style="list-style-type: none"> 1. Inspect CAN bus for short circuit and rectify short circuit as necessary. 2. Check shielding, improve as necessary. 3. Contact Service. 	2.0500.689
190	AL EMU Parameter Not Supported	Alarm configuration; EMU parameter are not supported.	Contact Service.	2.0500.690
201	SD T-Coolant	SD alarm configuration; Coolant temperature sensor faulty; short circuit or wire break.	Check sensor and cabling (B6), replace as necessary. Error cleared after restarting the engine.	1.8004.570
202	SD T-Fuel	SD alarm configuration; Fuel temperature sensor faulty; short circuit or wire break.	Check sensor and cabling (B33), replace as necessary. Error cleared after restarting the engine.	1.8004.572
203	SD T-Charge Air	SD alarm configuration; Charge-air temperature sensor faulty; short circuit or wire break.	Check sensor and cabling (B9), replace as necessary. Error cleared after restarting the engine.	1.8004.571

Fault code No.	Designation	Meaning	Task	Related parameter No.
204	SD T-Coolant Intercooler	SD alarm configuration; Intercooler coolant temperature sensor faulty; short circuit or wire break.	Check sensor and cabling (B26), replace as necessary. Error cleared after restarting the engine.	1.8004.574
205	SD T-Exhaust A	SD alarm configuration; Exhaust temperature sensor on A-side faulty; short circuit or wire break.	Check sensor and cabling (B4.21), replace as necessary. Error cleared after restarting the engine.	1.8004.576
206	SD T-Exhaust B	SD alarm configuration; Exhaust temperature sensor on B-side faulty; short circuit or wire break.	Check sensor and cabling (B4.22), replace as necessary. Error cleared after restarting the engine.	1.8004.577
208	SD P-Charge Air	SD alarm configuration; Charge-air pressure sensor faulty; short circuit or wire break.	Check sensor and cabling (B10), replace as necessary. Error cleared after restarting the engine.	1.8004.566
211	SD P-Lube Oil	SD alarm configuration; Lube oil pressure sensor faulty; short circuit or wire break.	Check sensor and cabling (B5), replace as necessary. Error cleared after restarting the engine.	1.8004.563
212	SD P-Coolant	SD alarm configuration; Coolant pressure sensor faulty; short circuit or wire break.	Check sensor and cabling (B16), replace as necessary. Error cleared after restarting the engine.	1.8004.564
213	SD P-Coolant Intercooler	SD alarm configuration; Intercooler coolant pressure sensor faulty; short circuit or wire break.	Check sensor and cabling (B43), replace as necessary. Error cleared after restarting the engine.	1.8004.569
214	SD P-CrankCase	SD alarm configuration; Crankcase pressure sensor faulty; short circuit or wire break.	Check sensor and cabling (B50), replace as necessary. Error cleared after restarting the engine.	1.8004.568
215	SD P-HD	SD alarm configuration; Rail pressure sensor faulty; HP regulator in emergency mode, short circuit or wire break.	Check sensor and cabling (B48), replace as necessary. Error cleared after restarting the engine.	1.8004.567

Fault code No.	Designation	Meaning	Task	Related parameter No.
216	SD T-Lube Oil	SD alarm configuration; Lube oil temperature sensor faulty; short circuit or wire break.	Check sensor and cabling (B7), replace as necessary. Error cleared after restarting the engine.	1.8004.575
219	SD T-Intake Air	SD alarm configuration; Intake air temperature sensor faulty; short circuit or wire break.	Check sensor and cabling (B3), replace as necessary. Error cleared after restarting the engine.	1.8004.573
220	SD Coolant Level	SD alarm configuration; Coolant level sensor faulty; short circuit or wire break.	Check sensor and cabling (F33), replace as necessary. Error cleared after restarting the engine.	1.8004.584
221	SD Dif Lube Oil	SD alarm configuration; Lube oil pressure differential sensor faulty; short circuit or wire break.	Check sensor and cabling (F25), replace as necessary. Error cleared after restarting the engine.	1.8004.585
222	SD Leak-Fuel Level	SD alarm configuration; Leak-off fuel level sensor faulty; short circuit or wire break.	Check sensor and cabling (F46), replace as necessary. Error cleared after restarting the engine.	1.8004.582
223	SD Level Coolant Intercooler	SD alarm configuration; Sensor for intercooler coolant level faulty; short circuit or wire break.	Check sensor and cabling (F57), replace as necessary. Error cleared after restarting the engine.	1.8004.583
227	SD P-Oil bef. Filter	SD alarm configuration; Sensor for lube oil pressure before filter faulty; short circuit or wire break.	Check sensor and cabling (B5.3), replace as necessary. Error cleared after restarting the engine.	1.8004.620
229	AL Stop Camshaft Sensor Defect	Alarm configuration; Engine stop due to camshaft sensor fault (and a prior crankshaft sensor fault in the same operating cycle).	Check connector and cabling to sensor B1, replace as necessary. Error cleared after restarting the engine.	1.8004.562
230	SD crankshaft	SD alarm configuration; Crankshaft sensor faulty; short circuit or wire break.	Check sensor and cabling (B13), replace as necessary. Error cleared after restarting the engine.	1.8004.498

Fault code No.	Designation	Meaning	Task	Related parameter No.
231	SD camshaft	SD alarm configuration; Camshaft sensor faulty; short circuit or wire break.	Check sensor and cabling (B1), replace as necessary. Error cleared after restarting the engine.	1.8004.499
232	SD ETC Speed 1	SD alarm configuration; Speed sensor of primary turbocharger faulty; short circuit or wire break.	Check sensor and cabling (B44.1), replace as necessary. Error cleared after restarting the engine.	1.3011.128
233	SD ETC Speed 2	SD alarm configuration; Speed sensor of secondary turbocharger faulty; short circuit or wire break.	Check sensor and cabling (B44.2), replace as necessary. Error cleared after restarting the engine.	1.3011.129
240	SD P-Fuel	SD alarm configuration; Fuel pressure sensor faulty; short circuit or wire break.	Check sensor and cabling (B34), replace as necessary. Error cleared after restarting the engine.	1.8004.565
241	SD T-Recirculation	SD alarm configuration; Recirculation sensor faulty; short circuit or wire break.	Check sensor and cabling (B49), replace as necessary. Error cleared after restarting the engine.	1.8004.581
242	SD T-Coolant Redundant	SD alarm configuration; Redundant coolant pressure sensor faulty; short circuit or wire break.	Check sensor and cabling, replace as necessary. Error cleared after restarting the engine.	1.8004.622
244	SD Oil Press Redundant	SD alarm configuration; Redundant lube oil pressure sensor faulty; short circuit or wire break.	Check sensor and cabling, replace as necessary. Error cleared after restarting the engine.	1.8004.621
245	SD ECU Supply Voltage	SD alarm configuration; Internal ECU fault; Electronics faulty.	Replace ECU.	2.8006.589
266	SD Speed Demand	SD alarm configuration; Analog speed demand faulty; short circuit or wire break.	1. Check cabling 2. Check speed demand signal.	2.8006.586
269	SD Loadp.Analog filt	SD alarm configuration; Filtered analog signal of load pulse missing; short circuit or wire break.	Check cabling, replace as necessary. Error cleared after restarting the engine.	2.8006.588

Fault code No.	Designation	Meaning	Task	Related parameter No.
270	SD Frequency Input	SD alarm configuration; Frequency input faulty; short circuit or wire break.	<ol style="list-style-type: none"> 1. Check cabling 2. Check setpoint speed transmitter. 3. Contact Service. 	2.8006.590
301	AL Timing Cylinder A1	Alarm configuration; Time-of-flight measuring fault of injector: Time-of flight measured value extremely low or extremely high.	Replace injector concerned if the fault message appears frequently (→ Page 109).	1.8004.500
302	AL Timing Cylinder A2			1.8004.501
303	AL Timing Cylinder A3			1.8004.502
304	AL Timing Cylinder A4			1.8004.503
305	AL Timing Cylinder A5			1.8004.504
306	AL Timing Cylinder A6			1.8004.505
307	AL Timing Cylinder A7			1.8004.506
308	AL Timing Cylinder A8			1.8004.507
309	AL Timing Cylinder A9			1.8004.508
310	AL Timing Cylinder A10			1.8004.509
311	AL Timing Cylinder B1			1.8004.510
312	AL Timing Cylinder B2			1.8004.511
313	AL Timing Cylinder B3			1.8004.512
314	AL Timing Cylinder B4			1.8004.513
315	AL Timing Cylinder B5			1.8004.514
316	AL Timing Cylinder B6			1.8004.515
317	AL Timing Cylinder B7			1.8004.516
318	AL Timing Cylinder B8			1.8004.517
319	AL Timing Cylinder B9			1.8004.518
320	AL Timing Cylinder B10			1.8004.519

Fault code No.	Designation	Meaning	Task	Related parameter No.
321	AL Wiring Cylinder A1	Alarm configuration; Cabling fault in injector cabling to cylinder. Result: Misfiring.	<ol style="list-style-type: none"> 1. Check solenoid valve. 2. Contact Service. 	1.8004.520
322	AL Wiring Cylinder A2			1.8004.521
323	AL Wiring Cylinder A3			1.8004.522
324	AL Wiring Cylinder A4			1.8004.523
325	AL Wiring Cylinder A5			1.8004.524
326	AL Wiring Cylinder A6			1.8004.525
327	AL Wiring Cylinder A7			1.8004.526
328	AL Wiring Cylinder A8			1.8004.527
329	AL Wiring Cylinder A9			1.8004.528
330	AL Wiring Cylinder A10			1.8004.529
331	AL Wiring Cylinder B1			1.8004.530
332	AL Wiring Cylinder B2			1.8004.531
333	AL Wiring Cylinder B3			1.8004.532
334	AL Wiring Cylinder B4			1.8004.533
335	AL Wiring Cylinder B5			1.8004.534
336	AL Wiring Cylinder B6			1.8004.535
337	AL Wiring Cylinder B7			1.8004.536
338	AL Wiring Cylinder B8			1.8004.537
339	AL Wiring Cylinder B9			1.8004.538
340	AL Wiring Cylinder B10			1.8004.539

Fault code No.	Designation	Meaning	Task	Related parameter No.
341	AL Open Load Cylinder A1	Alarm configuration; Disruption fault in injector cabling to cylinder. Result: Misfiring.	1. Check solenoid valve. 2. Contact Service.	1.8004.540
342	AL Open Load Cylinder A2			1.8004.541
343	AL Open Load Cylinder A3			1.8004.542
344	AL Open Load Cylinder A4			1.8004.543
345	AL Open Load Cylinder A5			1.8004.544
346	AL Open Load Cylinder A6			1.8004.545
347	AL Open Load Cylinder A7			1.8004.546
348	AL Open Load Cylinder A8			1.8004.547
349	AL Open Load Cylinder A9			1.8004.548
350	AL Open Load Cylinder A10			1.8004.549
351	AL Open Load Cylinder B1			1.8004.550
352	AL Open Load Cylinder B2			1.8004.551
353	AL Open Load Cylinder B3			1.8004.552
354	AL Open Load Cylinder B4			1.8004.553
355	AL Open Load Cylinder B5			1.8004.554
356	AL Open Load Cylinder B6			1.8004.555
357	AL Open Load Cylinder B7			1.8004.556
358	AL Open Load Cylinder B8			1.8004.557
359	AL Open Load Cylinder B9			1.8004.558
360	AL Open Load Cylinder B10			1.8004.559

Fault code No.	Designation	Meaning	Task	Related parameter No.
361	AL Power Stage Low	Alarm configuration; Internal electronic fault (electronics possibly faulty: Start ITS). If the ITS diagnosis result is "electronics OK", note further fault messages (e.g. cabling faults).	<ol style="list-style-type: none"> 1. Check solenoid valve cabling. 2. Replace ECU. 	1.8004.496
362	AL Power Stage High	Alarm configuration; Internal electronic fault (electronics possibly faulty: Start ITS). If the ITS diagnosis result is "electronics OK", note further fault messages (e.g. cabling faults).	<ol style="list-style-type: none"> 1. Check solenoid valve cabling. 2. Replace ECU. 	1.8004.497
363	AL Stop Power Stage	Alarm configuration; Internal electronic fault (electronics possibly faulty: Start ITS).	<ol style="list-style-type: none"> 1. Check cabling 2. Attempt to restart engine. 	1.8004.560
365	AL Stop MV-Wiring Ground	Alarm configuration; Injector cabling fault. If bit "1.1020.021" (Power Stage Failure: Stop Engine) is set, engine will be shut down as additional measure. 1. Short circuit of positive connection of one or more injectors to ground 2. Short circuit of negative connection of one or more injectors to ground .	<ol style="list-style-type: none"> 1. Check cabling 2. Attempt to restart engine. 	1.8004.561
371	AL Wiring TO 1	Alarm configuration; Short circuit or wire break on transistor output 1 (TO 1).	<ol style="list-style-type: none"> 1. Check turbocharger valve/cabling, repair as necessary. 2. Replace ECU. 	1.8004.634
372	AL Wiring TO 2	Alarm configuration; Short circuit or wire break on transistor output 2 (TO 2).	<ol style="list-style-type: none"> 1. Check recirculation valve/cabling, repair as necessary. 2. Replace ECU. 	1.8004.635
373	AL Wiring TO 3	Alarm configuration; Short circuit or wire break on transistor output 3 (TO 3).	-	1.8004.636
374	AL Wiring TO 4	Alarm configuration; Short circuit or wire break on transistor output 4 (TO 4).	-	1.8004.637
381	AL Wiring TOP 1	Alarm configuration; Short circuit or wire break on transistor output, plant-side 1 (TOP 1).	Check cabling to plant.	2.8006.638

Fault code No.	Designation	Meaning	Task	Related parameter No.
382	AL Wiring TOP 2	Alarm configuration; Short circuit or wire break on transistor output, plant-side 2 (TOP 2).	Check cabling to plant.	2.8006.639
383	AL Wiring TOP 3	Alarm configuration; Short circuit or wire break on transistor output, plant-side 3 (TOP 3).	Check cabling to plant.	2.8006.640
384	AL Wiring TOP 4	Alarm configuration; Short circuit or wire break on transistor output, plant-side 4 (TOP 4).	Check cabling to plant.	2.8006.641
390	AL MCR exceeded	Alarm configuration; DBR/MCR function: MCR has been exceeded.	<ol style="list-style-type: none"> 1. If alarm is only temporary, no action required; 2. if alarm is continuously active, contact Service. 	1.1085.009
392	HI T-Coolant Redundant	Alarm configuration limit value 1; Preliminary warning: Redundant coolant temperature reading too high.	<ol style="list-style-type: none"> 1. Check cabling 2. Contact Service. 	2.0129.931
393	SS T-Coolant Redundant	Alarm configuration limit value 1; Main warning: Redundant coolant temperature reading too high; Engine stop.	<ol style="list-style-type: none"> 1. Check cabling and sensor. 2. Contact Service. 	2.0129.932
394	LO P-Lube Oil Redundant	Alarm configuration limit value 1; Preliminary warning: Redundant lube oil pressure reading too low.	<ol style="list-style-type: none"> 1. Check cabling and sensor. 2. Contact Service. 	2.0112.921
395	SS P-Lube Oil Redundant	Alarm configuration limit value 2; Main warning: Redundant lube oil pressure reading too low.	<ol style="list-style-type: none"> 1. Check cabling and sensor. 2. Contact Service. 	2.0112.922
396	AL T-Coolant Max Deviation	Alarm configuration; Maximum coolant temperature deviation.	<ol style="list-style-type: none"> 1. Check cabling and sensor. 2. Contact Service. 	1.8004.626
397	AL P-Oil Max Deviation	Alarm configuration; Maximum lube oil pressure deviation.	<ol style="list-style-type: none"> 1. Check cabling and sensor. 2. Contact Service. 	1.8004.625
400	AL Open Load Digital Input 1	Alarm configuration; Line disruption on digital input 1; Cabling faulty or no resistance over switch.	<ol style="list-style-type: none"> 1. Check cabling 2. Check input of target device. 3. Contact Service. 	2.8006.625

Fault code No.	Designation	Meaning	Task	Related parameter No.
401	AL Open Load Digital Input 2	Alarm configuration; Line disruption on digital input 2; Cabling faulty or no resistance over switch.	<ol style="list-style-type: none"> 1. Check cabling 2. Check input of target device. 3. Contact Service. 	2.8006.626
402	AL Open Load Digital Input 3	Alarm configuration; Line disruption on digital input 3; Cabling faulty or no resistance over switch.	<ol style="list-style-type: none"> 1. Check cabling 2. Check input of target device. 3. Contact Service. 	2.8006.627
403	AL Open Load Digital Input 4	Alarm configuration; Line disruption on digital input 4; Cabling faulty or no resistance over switch.	<ol style="list-style-type: none"> 1. Check cabling 2. Check input of target device. 3. Contact Service. 	2.8006.628
404	AL Open Load Digital Input 5	Alarm configuration; Line disruption on digital input 5; Cabling faulty or no resistance over switch.	<ol style="list-style-type: none"> 1. Check cabling 2. Check input of target device. 3. Contact Service. 	2.8006.629
405	AL Open Load Digital Input 6	Alarm configuration; Line disruption on digital input 6; Cabling faulty or no resistance over switch.	<ol style="list-style-type: none"> 1. Check cabling 2. Check input of target device. 3. Contact Service. 	2.8006.630
406	AL Open Load Digital Input 7	Alarm configuration; Line disruption on digital input 7; Cabling faulty or no resistance over switch.	<ol style="list-style-type: none"> 1. Check cabling 2. Check input of target device. 3. Contact Service. 	2.8006.631
407	AL Open Load Digital Input 8	Alarm configuration; Line disruption on digital input 8; Cabling faulty or no resistance over switch.	<ol style="list-style-type: none"> 1. Check cabling 2. Check input of target device. 3. Contact Service. 	2.8006.632
408	AL Open Load Emerg. Stop Input ESI	Alarm configuration; Line disruption on the input for emergency stop; Cabling faulty or no resistance over switch.	<ol style="list-style-type: none"> 1. Check cabling 2. Check input of target device. 3. Contact Service. 	2.8006.633
410	LO U-PDU	Alarm configuration limit value 1; Preliminary warning: Injector voltage too low.	<ol style="list-style-type: none"> 1. Check cabling. 2. Check power supply. 3. Contact Service. 	2.0141.921
411	LOLO U-PDU	Alarm configuration limit value 2; Main warning: Injector voltage too low.	<ol style="list-style-type: none"> 1. Check cabling 2. Check power supply. 3. Contact Service. 	2.0141.922

Fault code No.	Designation	Meaning	Task	Related parameter No.
412	HI U-PDU	Alarm configuration limit value 1; Preliminary warning: Injector voltage too high.	<ol style="list-style-type: none"> 1. Check cabling 2. Check power supply. 3. Contact Service. 	2.0141.931
413	HIHI U-PDU	Alarm configuration limit value 2; Main warning: Injector voltage too high.	<ol style="list-style-type: none"> 1. Check cabling 2. Check power supply. 3. Contact Service. 	2.0141.932
414	HI Water Level Fuel Prefilter	Alarm configuration limit value 1; Warning: water level in fuel prefilter too high.	Drain water (→ Page 118).	2.0156.931
415	LO P-Coolant Intercooler	Alarm configuration limit value 1; Preliminary warning: Coolant pressure in intercooler too low.	Top up coolant (→ Page 147).	2.0107.921
416	SS P-Coolant Intercooler	Alarm configuration limit value 2; Main warning: Coolant pressure in intercooler too low. Engine stop.	Top up coolant (→ Page 147).	2.0107.922
417	SD Water Level Fuel Prefilter	SD alarm configuration; Sensor for water level in fuel prefilter faulty; short circuit or wire break.	Check sensor and cabling, replace as necessary. Error cleared after restarting the engine.	1.8004.594
420	L1 Aux 1	Alarm configuration limit value 1; Input signal of Aux 1 has exceeded/not attained limit value 1, depending on configuration.	Determine and rectify reason for limit value violation.	2.0160.921
421	L2 Aux 1	Alarm configuration limit value 1; Input signal of Aux 1 has exceeded/not attained limit value 2, depending on configuration.	Determine and rectify reason for limit value violation.	2.0160.922
428	L1 T-Aux 1	Alarm configuration limit value 1; Preliminary warning: Temperature signal of Aux 1 has exceeded / not attained limit value 1, depending on configuration.	Determine and rectify reason for limit value violation.	2.0130.921
432	L1 T-Aux 2	Alarm configuration limit value 1; Preliminary warning: Temperature signal of Aux 2 has exceeded / not attained limit value 1, depending on configuration.	Determine and rectify reason for limit value violation.	2.0131.921

Fault code No.	Designation	Meaning	Task	Related parameter No.
433	L2 T-Aux 2	Alarm configuration limit value 2; Preliminary warning: Temperature signal of Aux 2 has exceeded / not attained limit value 2, depending on configuration.	Determine and rectify reason for limit value violation.	2.0131.922
436	L1 P-Aux 2	Alarm configuration limit value 1; Preliminary warning: Pressure signal of Aux 2 has exceeded / not attained limit value 1, depending on configuration.	Determine and rectify reason for limit value violation.	2.0111.921
437	L2 P-Aux 2	Alarm configuration limit value 2; Preliminary warning: Pressure signal of Aux 2 has exceeded / not attained limit value 2, depending on configuration.	Determine and rectify reason for limit value violation.	2.0111.922
440	L1 P-Aux 1	Alarm configuration limit value 1; Preliminary warning: Pressure signal of Aux 1 has exceeded / not attained limit value 1, depending on configuration.	Determine and rectify reason for limit value violation.	2.0110.921
442	L2 P-Aux 1	Alarm configuration limit value 2; Preliminary warning: Pressure signal of Aux 1 has exceeded / not attained limit value 2, depending on configuration.	Determine and rectify reason for limit value violation.	2.0110.931
444	SD U-PDU	SD alarm configuration; Injector power stage sensor defect; Internal fault in ECU.	Replace ECU.	1.8004.578
445	SD P-Ambient Air	SD alarm configuration; Ambient air pressure sensor faulty.	Replace ECU.	1.8004.580
448	HI P-Charge Air	Alarm configuration limit value 1; Preliminary warning: Charge-air pressure too high.	Contact Service.	2.0103.931
449	SS P-Charge Air	Alarm configuration limit value 2; Main warning: Charge-air pressure too high.	Contact Service.	2.0103.932
450	SD Idle/End-Torque Input [%]	SD alarm configuration; Input signal for initial/final torque faulty; short circuit or wire break.	Check signal transmitter and cabling, replace as necessary. Error cleared after restarting the engine.	2.8006.592

Fault code No.	Designation	Meaning	Task	Related parameter No.
454	SS Power Reduction Active	Alarm configuration; power reduction is active.	<ol style="list-style-type: none"> 1. Note further fault messages. 2. Determine and rectify reason for power reduction. 	2.7000.011
455	AL Aux 1 Plant L1	Alarm configuration limit value 1; Input signal of Aux 1 (plant side) has exceeded/not attained limit value 1, depending on configuration.	Determine and rectify reason for limit value violation.	2.8006.650
456	AL Aux 1 Plant L2	Alarm configuration limit value 2; Input signal of Aux 1 (plant side) has exceeded/not attained limit value 2, depending on configuration.	Determine and rectify reason for limit value violation.	2.8006.651
460	AL Exhaust EMU High	Alarm configuration limit value; EMU exhaust temperature value too high.	<ol style="list-style-type: none"> 1. Check cabling 2. Contact Service. 	2.8006.652
461	AL Exhaust EMU Low	Alarm configuration limit value; EMU exhaust temperature value too low.	<ol style="list-style-type: none"> 1. Check cabling 2. Contact Service. 	2.8006.653
462	AL Coolant EMU L1	Alarm configuration limit value; EMU coolant temperature value too high / low.	Check configuration with DiaSys.	2.8006.654
463	SD AUX 2	SD alarm configuration; Analog input signal for Aux 2 faulty; short circuit or wire break.	<p>Check signal transmitter and cabling, replace as necessary.</p> <p>Error cleared after restarting the engine.</p>	1.8004.591
464	SD P-AUX 1	SD alarm configuration; Analog input signal for Aux 1 pressure faulty; short circuit or wire break.	<p>Check pressure transmitter and cabling, replace as necessary.</p> <p>Error cleared after restarting the engine.</p>	1.8004.589
465	SD P-AUX 2	SD alarm configuration; Analog input signal for Aux 2 pressure faulty; short circuit or wire break.	<p>Check pressure transmitter and cabling, replace as necessary.</p> <p>Error cleared after restarting the engine.</p>	1.8004.588
466	SD T-AUX 2	SD alarm configuration; Analog input signal for Aux 2 temperature faulty; short circuit or wire break.	<p>Check temperature sensor and cabling, replace as necessary.</p> <p>Error cleared after restarting the engine.</p>	1.8004.586

Fault code No.	Designation	Meaning	Task	Related parameter No.
467	L2 T-Aux 1	Alarm configuration limit value 2; Preliminary warning: Temperature signal of Aux 1 has exceeded / not attained limit value 2, depending on configuration.	Determine and rectify reason for limit value violation.	2.0130.922
468	SD T-AUX 1	SD alarm configuration; Analog input for Aux 1 temperature faulty.	Replace ECU.	1.8004.579
469	SD AUX 1	SD alarm configuration; Analog input signal for Aux 1 faulty; short circuit or wire break.	Check signal transmitter and cabling, replace as necessary. Error cleared after restarting the engine.	1.8004.590
470	SD T-ECU	SD alarm configuration; Temperature sensor for ECU faulty; short circuit or wire break.	Check sensor and cabling, replace as necessary. Error cleared after restarting the engine.	1.8004.587
471	SD Coil Current	SD alarm configuration; Control of HP fuel control block faulty; short circuit or wire break.	Check sensor and cabling, replace as necessary. Error cleared after restarting the engine.	1.8004.592
472	AI Stop SD	Alarm configuration; Engine shutdown, since all shutdown channels have "sensor faulty".	1. Check cabling 2. Contact Service.	2.8006.593
473	AL Cabling PWM_CM2	Alarm configuration; Cable break or short circuit on channel PWM_CM2.	1. Check cabling 2. Contact Service.	1.8004.593
474	AL Wiring FO	Alarm configuration; Cable break or short circuit on channel FO.	1. Check cabling 2. Contact Service.	2.8006.655
475	AL CR Trigger Engine Stop	Alarm configuration; Tripped by crash recorder triggering due to engine shutdown.	Determine and rectify cause of triggering / engine shutdown.	1.8010.009
476	AL Crash Rec. Init. Error	Alarm configuration; Crash recorder initialization error.	Check setting with DiaSys.	1.8010.007
478	AL Comb. Alarm Yel (Plant)	Alarm configuration; Combined alarm YELLOW from plant.	Note further fault messages.	2.8006.001
479	AL Comb. Alarm Red (Plant)	Alarm configuration; Combined alarm RED from plant.	Note further fault messages.	2.8006.002

6 Task Description

6.1 Engine

6.1.1 Engine – Barring manually

Preconditions

- Engine is stopped and starting disabled.

Special tools

Designation / Use	Part No.	Qty.
Barring tool	F6555766	1
Ratchet	F30006212	1



Unguarded rotating and moving engine components.

Risk of serious injury — danger to life!

- Before barring the engine, ensure that nobody is in the danger zone.

Engine – Barring manually

1. Remove guard plate.
2. Engage barring tool (2) with ring gear (3) and mount on flywheel housing.
3. Set ratchet (1) onto barring tool (2).
4. Rotate crankshaft in engine direction of rotation. Apart from the normal compression resistance, there should be no abnormal resistance.
5. For barring-tool removal follow reverse sequence of working steps.

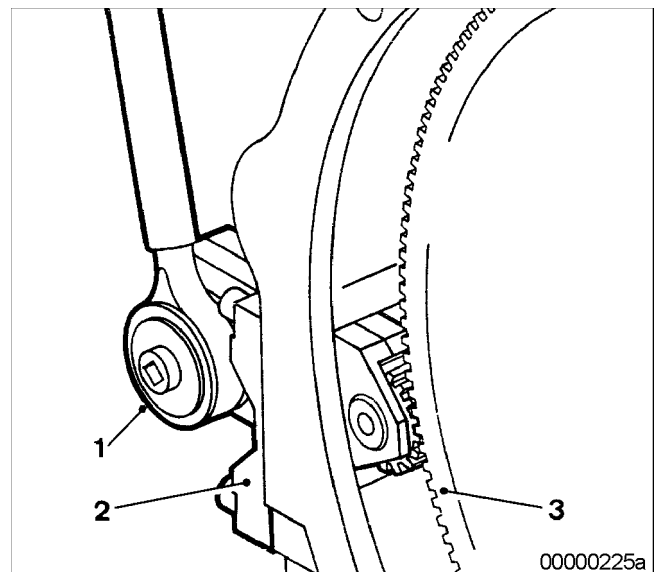

6.1.2 Engine – Barring with starting system



DANGER

Unguarded rotating and moving engine components.

Risk of serious injury - danger to life!

- Before barring or starting the engine, ensure that nobody is in the danger zone.
- After working on the engine, check that all protective devices have been reinstalled and all tools removed from the engine.

Engine – Barring with starting system

1. Release latch of connector X4.
2. Disconnect connector from ECU.
3. Bar engine in unloaded condition: Press START button.
4. Let the crankshaft rotate until oil pressure is indicated.
5. Engine start is automatically interrupted when specified starting period is expired. If necessary, re-start the engine after approx. 20 seconds.
6. Connect connector X4 to ECU and latch in position.

6.1.3 Engine test run



DANGER

Unguarded rotating and moving engine components.

Risk of serious injury — danger to life!

- Before barring or starting the engine, ensure that nobody is in the danger zone.



WARNING

Engine noise above 85 dB (A).

Risk of damage to hearing!

- Wear ear protectors.

Engine test run

1. Start engine (→ Page 57).
2. Perform test run at not below 1/3 load and at least until steady-state temperature is reached.
3. Carry out operational checks (→ Page 59).
4. Stop engine (→ Page 60).

6.2 Cylinder Liner

6.2.1 Cylinder liner – Endoscopic examination

Preconditions

- Engine is stopped and starting disabled.

Special tools

Designation / Use	Part No.	Qty.
Rigid endoscope	Y20097353	1

Preparatory steps

1. Remove cylinder-head cover (→ Page 108).
2. Remove injector (→ Page 110).

Positioning crankshaft at BDC

1. Using barring device, turn crankshaft until crankpin of the cylinder to be tested has reached BDC.
2. Insert endoscope into cylinder liner through injector seat.

Cylinder liner - Endoscopic examination

Findings	Task
<ul style="list-style-type: none"> • Thin carbon coating on carbon scraper ring • Slight localized additive deposits at top edge • Localized smooth areas at lower edge • Carbon deposits on entire circumference between top piston ring and lower edge of carbon scraper ring • First signs of marks left by top piston ring • Bright mark on entire circumference • Faultless, even honing pattern • First signs of marks left by lower cooling bores • Running pattern seems darker 	No actions required
<ul style="list-style-type: none"> • Darker areas of even or varying color intensity • Beginning and end of the discoloration are not sharply defined and do not cover the entire stroke area • Dark areas in the upper section of the cooling bore, remaining circumference cannot be faulted • Piston rings cannot be faulted 	Further endoscopic examination required as part of maintenance work
<ul style="list-style-type: none"> • On the entire circumference not only bright discoloration (not critical for operation) clearly visible darker stripes that begin at the top piston ring • Heat discoloration in the direction of stroke and honing pattern damage • Heat discoloration of piston rings 	Cylinder liner must be replaced; Service must be contacted

1. Compile endoscopy report using the table.
2. Use technical terms for description of the liner surface (→ Page 100).
3. Depending on findings:
 - Do not take any action or
 - carry out further endoscopic examination as part of maintenance work or
 - contact Service: cylinder liner must be replaced.

Final steps

1. Install injector (→ Page 110).
2. Install cylinder-head cover (→ Page 108).

6.2.2 Instructions and comments on endoscopic and visual examination of cylinder liners

Terms used for endoscopic examination

Use the terms listed below to describe the condition of the cylinder-liner surface in the endoscopic examination report.

Minor dirt scores	Light scoring can take place during the assembly of a new engine (honing products, particles, broken-off burrs). Removed cylinders clearly show such scoring on the running surface under endoscope magnification. Cannot be felt with the fingernail. Findings not critical.
Single scores	Clearly visible scores from hard particles. They usually start in the TDC area and cross through the hone pattern in the direction of stroke. Findings not critical.
Scored area	These areas consist of scores of different length and depth next to one another. In most cases, they are found at the 6-o'clock and 12-o'clock positions (inlet/exhaust) along the transverse engine axis. Findings not critical.
Smoothened area	Smoothened areas are on the running surface but almost the whole honing pattern is still visible. Smoothened areas appear brighter and more brilliant than the surrounding running surface. Findings not critical.
Polished area	Polished areas are on the running surface and show local removal of the honing pattern. Grooves from honing process are not visible any more.
Discoloration	This is caused by oxidation (surface discoloration through oil or fuel) and temperature differences around the liner. It appears rather darker within the honed structure in contrast to the bright metallic running surface. The honing pattern is undisturbed. Discolorations extend in stroke direction and may be interrupted. Findings not critical.
Corrosion fields / spots	Corrosion fields / spots result from water (condensed water) with the valves in the overlap (open) position. They are clearly visible due to the dark color of the honing groove bottom. This corrosion is not critical unless there are corrosion pittings.
Black lines	Black lines are a step towards heat discoloration. They are visible as a clear discoloration from TDC to BDC in the running surface and the start of localized damage to the honing pattern. Cylinders with a number of black lines around the running surface have limited service life and should be replaced.
Discolorations (Heat)	These are caused by a disturbance in the liner / ring tribosystem. Usually they run over the whole ring-travel area (TDC/BDC), starting at the first TDC-ring and becoming more visible from the second TDC-ring onwards and less pronounced from TDC-ring 1. The honing pattern is usually no longer visible and displays a clearly defined (straight) edge to the undisturbed surface. The damaged surface is usually discolored. The circumferential length varies. Liners with heat discoloration starting in the TDC-ring 1 have to be replaced.
Seizures, Seizure marks	Irregular circumference lengths and depths. Can be caused by either the piston skirt or the piston crown. Material deposits on the liner (smear), heavy discoloration. Severe, visible scoring. Replace liner.

Evaluation of findings and further measures

The findings in the start phase of oxidation discoloration and heat discoloration are similar. Thorough investigation and compliance with the above evaluation criteria allows a definite evaluation. To avoid unnecessary disassembly work, it is recommended that another inspection be carried out after further operation of the engine.

6.3 Crankcase Breather

6.3.1 Crankcase breather – Oil separator replacement, diaphragm check and replacement

Preconditions

- Engine is stopped and starting disabled.

Special tools

Designation / Use	Part No.	Qty.
Torque wrench 6-50 Nm	F30027336	1

Spare parts

Designation / Use	Part No.	Qty.
Filter element		
Diaphragm		
Seal		



WARNING

Hot oil.

Oil can contain combustion residues which are harmful to health.

Risk of injury and poisoning!

- Wear protective clothing, gloves, and goggles / safety mask.
- Avoid contact with skin.
- Do not inhale oil vapor.

Replacing oil separator

1. Remove cover (2) with O-ring (3).
2. Remove filter element (1) from housing (4).
3. Insert new filter element in housing (4).
4. Fit cover (2) with new O-ring.
5. Use torque wrench to tighten the screws of cover (2) to specified torque 10 Nm -2 Nm.
6. Replace further oil separator elements in the same way.

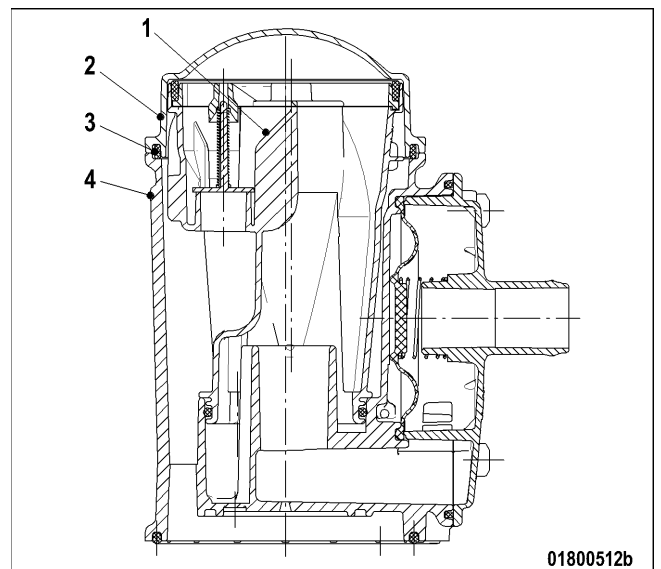

Checking diaphragm

1. Remove cover (4).
2. Take off spring (5), seal (2) and diaphragm (3).
3. Check diaphragm (3) for damage, fit new diaphragm if used one is damaged.
4. Mount diaphragm (3) on housing (1).
5. Install new seal (2) and spring (5) together with cover (4).
6. Use torque wrench to tighten the screws of cover (4) to specified torque 10 Nm -2 Nm.
7. Check diaphragms in further oil separators in the same way.

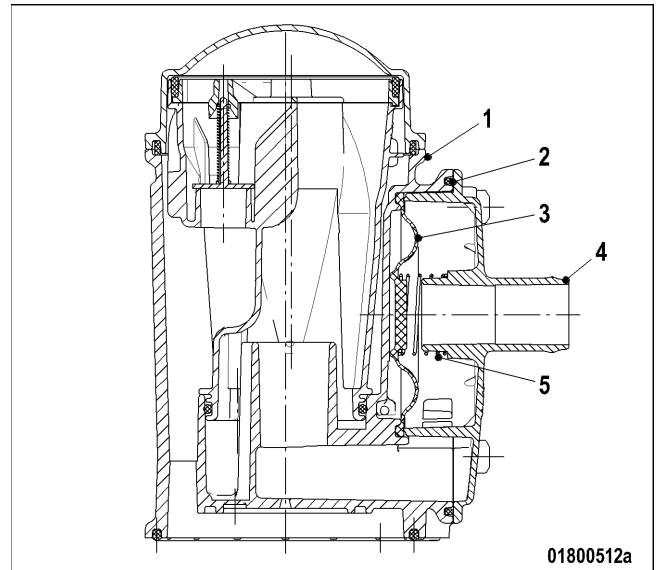

6.4 Valve Drive

6.4.1 Valve gear – Lubrication

Preconditions

- Engine is stopped and starting disabled.

Material

Designation / Use	Part No.	Qty.
Engine oil		

Valve gear – Lubrication

1. Remove cylinder head covers (→ Page 108).
2. Fill oil chambers of valve bridges with oil.
3. Fill oil chambers of rocker arms and adjusting screws with oil.
4. Install cylinder head covers (→ Page 108).

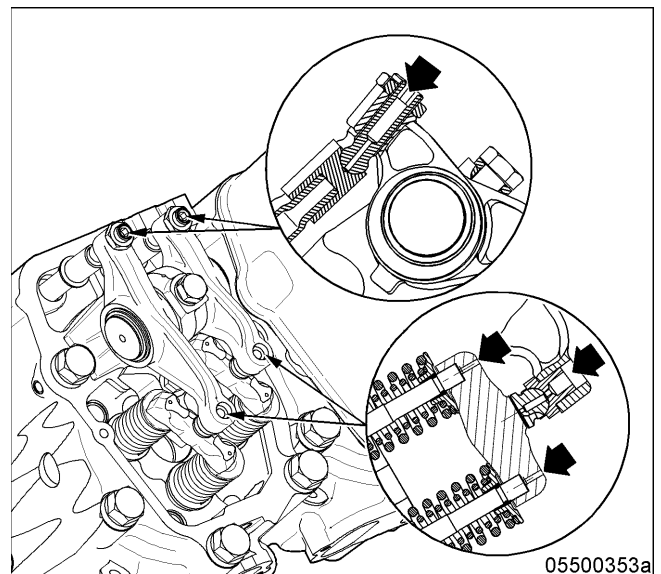

Diagram

- Two crankshaft positions
- Applicable to 16V engines

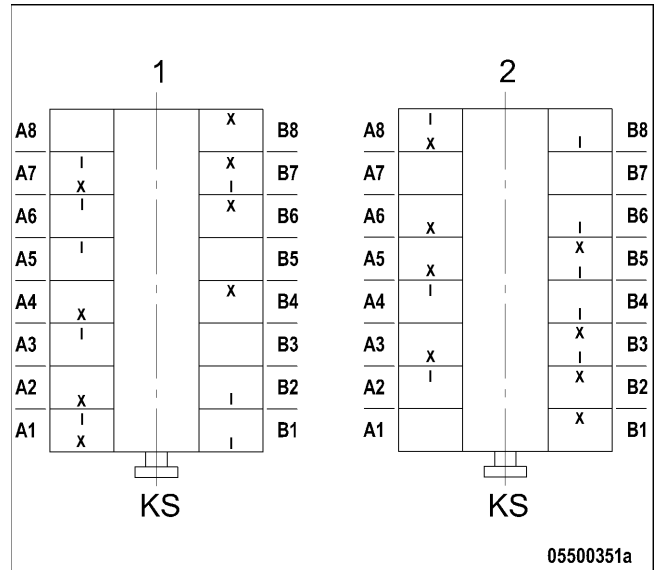

Diagram

- Two crankshaft positions
- Applicable to 20V engines

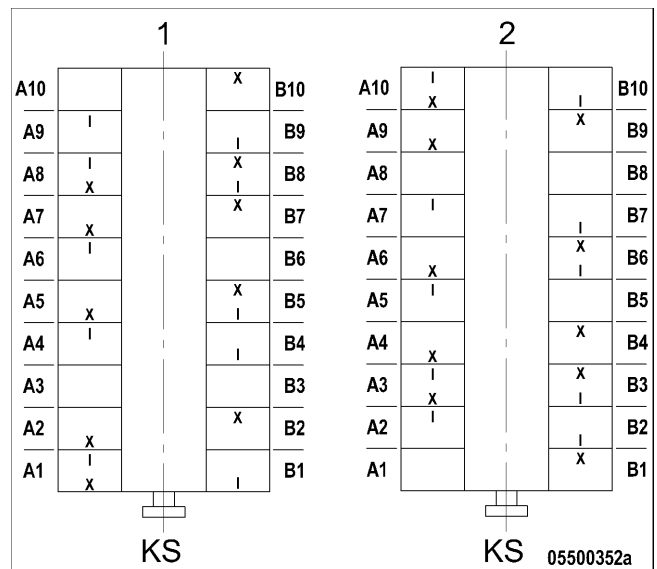

- 1 Cylinder A1 is in firing TDC
- 2 Cylinder A1 is in overlap TDC
- I Inlet valve
- X Exhaust valve

Checking valve clearance at two crankshaft positions

1. Check TDC position of piston in cylinder A1:
 - If the rocker arms are unloaded on cylinder A1, the piston is in firing TDC.
 - If the rocker arms are loaded on cylinder A1, the piston is in overlap TDC.
2. Check valve clearance with cold engine:
 - Inlet valves (long rocker arm) = 0.2 mm
 - Exhaust valves (short rocker arm) = 0.5 mm
3. Check all valve clearances at two crankshaft positions (firing and overlap TDC for cylinder A1) as per diagram.
4. Use feeler gauge to determine the distance between valve bridge and rocker arm.
5. If the deviation from the reference value exceeds 0.1 mm, adjust valve clearance.

Adjusting valve clearance

1. Release locknut (1).
2. Insert feeler gauge between valve bridge and rocker arm.
3. Using Allen key, set adjusting screw (2) so that the specified valve clearance is provided.
4. Feeler gauge must just pass through the gap.
5. Tighten locknut (1) to $90 +9$ Nm, holding adjusting screw (2) firm.
6. Replace or rectify adjusting screws and/or locknuts which do not move freely.
7. Check valve clearance.

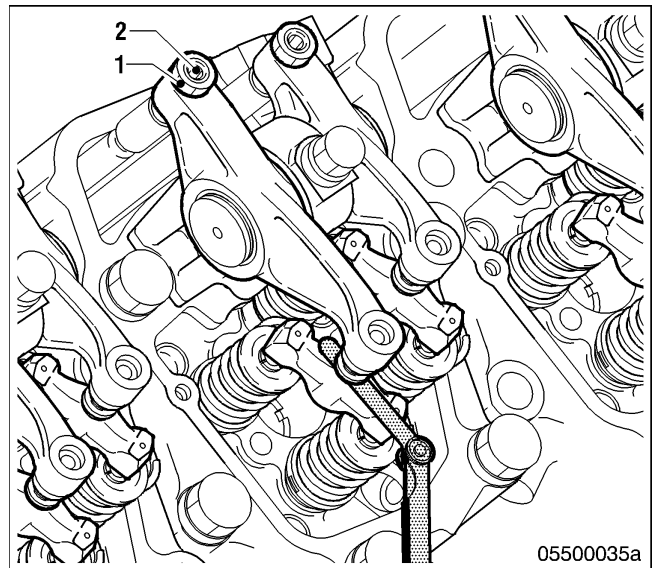
**Final steps**

1. Remove barring tool (→ Page 95).
2. Install cylinder head cover (→ Page 108).

6.4.3 Cylinder head cover – Remove and install

Preconditions

- Engine is stopped and starting disabled.

Special tools

Designation / Use	Part No.	Qty.
Torque wrench 10-60 Nm	F30510423	1

Spare parts

Designation / Use	Part No.	Qty.
Gasket		

Remove cylinder head cover

1. Clean very dirty cylinder head covers prior to removal.
2. Remove screws.
3. Remove cylinder head cover with gasket from cylinder head.

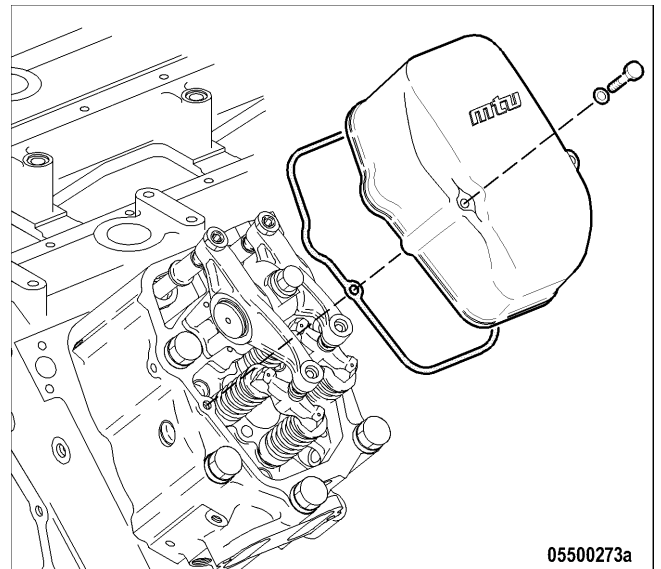

Install cylinder head cover

1. Clean mating faces.
2. Check condition of gasket, replace if necessary.
3. Place gasket and cylinder head cover on cylinder head.
4. Install screws and tighten to 42 Nm.

6.5 Injector

6.5.1 Injector – Replacement

Spare parts

Designation / Use	Part No.	Qty.
Injector		

Remove injector and install new one (→ Page 110).

6.5.2 Injector – Removal and Installation

Preconditions

- Engine is stopped and starting disabled.

Special tools

Designation / Use	Part No.	Qty.
Puller	F6784183	1
Press-in tool	F6784167	1
Torque wrench 10-60 Nm	F30510423	1
Socket wrench, 17 mm	F30025896	1
Socket wrench, 19 mm	F30025897	1
Torque wrench 60-320 Nm	F30047446	1
Ratchet adapter	F30027341	1

Material

Designation / Use	Part No.	Qty.
Petroleum jelly		



Fuels are combustible.

Risk of fire and explosion!

- Avoid naked flames, electrical sparks and ignition sources.
- Do not smoke.

Preparatory steps

1. Shut off fuel supply to engine.
2. Remove cylinder head cover (→ Page 108).

Injector removal

1. Withdraw cable connector on injector.

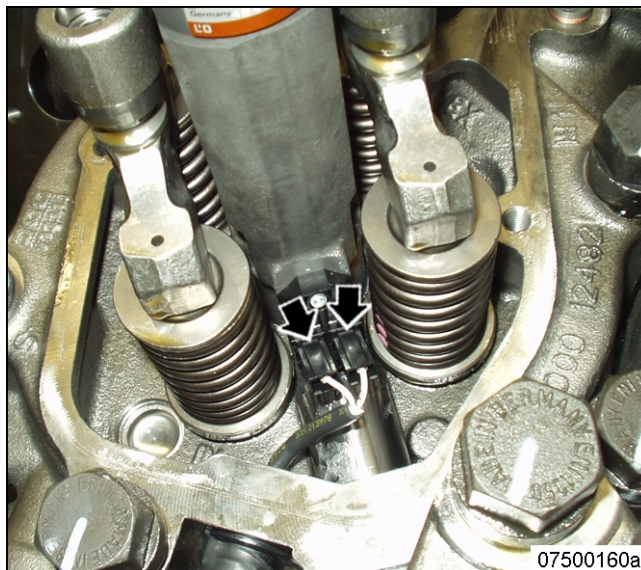

2. Remove screw (2) and take off hold-down clamp (1).
3. Remove HP fuel line (4).

Note: The injector accumulator will be emptied when removing the adapter.

4. Unscrew adapter (3) until only the last two to three courses of the thread are engaged.
5. Allow the fuel to drain off and collect it in a suitable container.
6. Unscrew adapter completely.

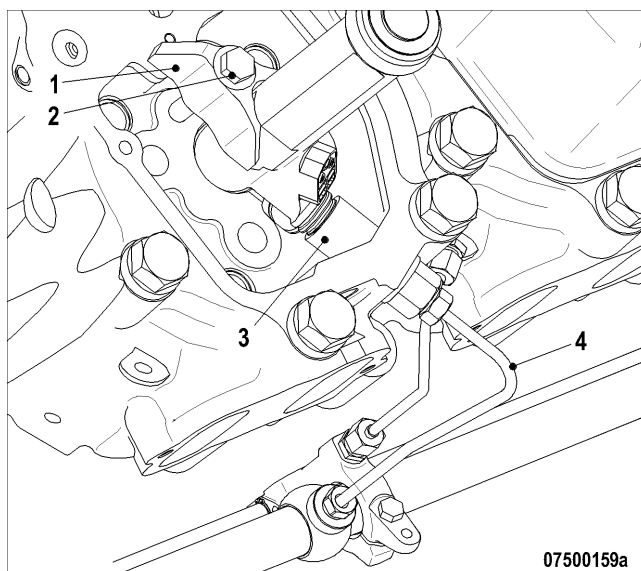

7. Fit puller and withdraw injector.

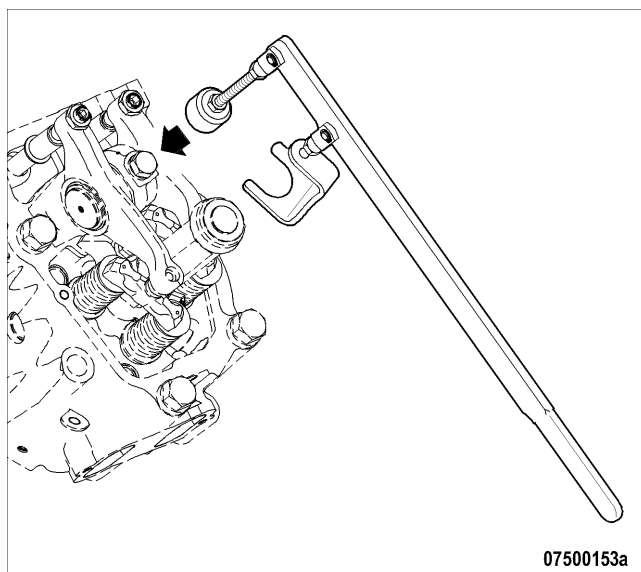

8. Remove sealing ring (1) from injector or use a self-made hook to take it out of the cylinder head.
9. Remove O-rings (2) from injector.
10. Cover all connections and bores, or seal with suitable plugs.

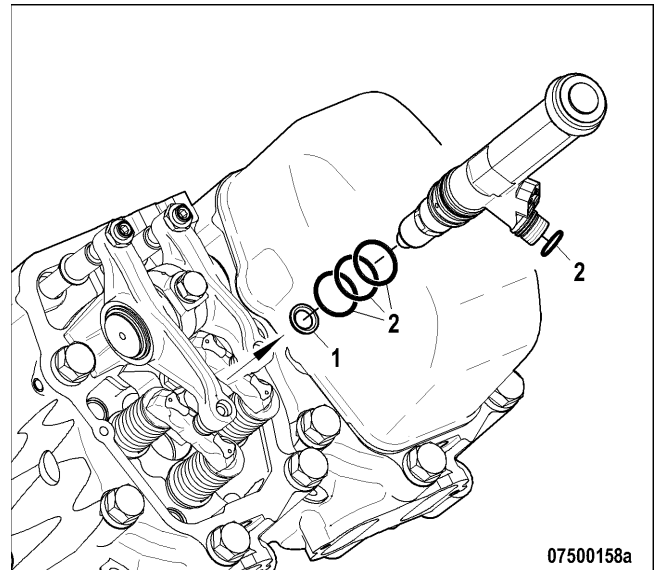

Injector installation

1. Remove all plugs prior to installation.
2. Coat new O-rings (scope of supply of injector) with petroleum jelly and fit on injector.
3. Fit new sealing ring with petroleum jelly on injector, observe installation position of sealing ring.

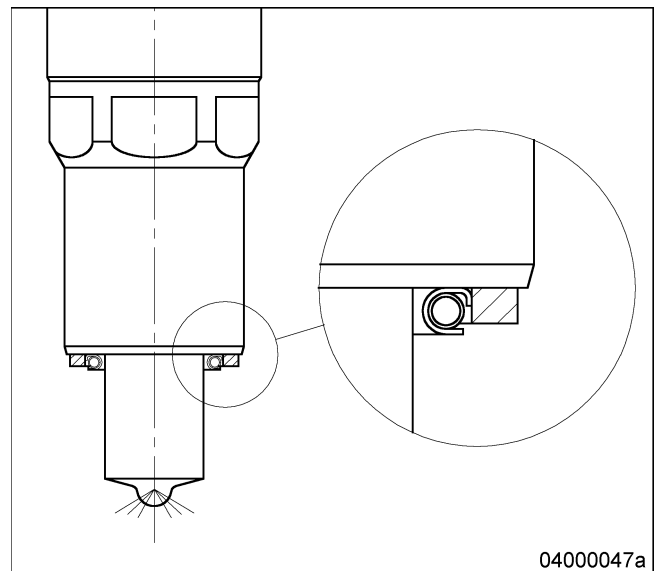

4. Clean sealing surface on cylinder head.
5. Insert injector into cylinder head, ensuring that correct adapter connection alignment.
6. Lock press-in tool in position between the rocker arms in the cylinder head recess (arrowed).
7. Use press-in tool to insert injector into cylinder head.

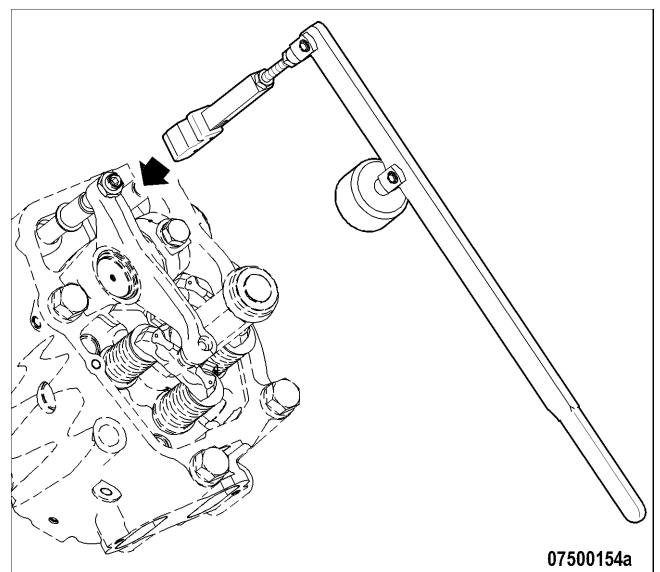

8. Coat screw head mating face and thread with engine oil.
9. Place hold-down clamp (1) in correct installation position and pretighten screw (2) with torque wrench to between 5 Nm and 10 Nm.
10. Coat thread and sealing cone of adapter (3) with engine oil.
11. Mount adapter (3) and use torque wrench to pretighten to between 5 Nm and 10 Nm.
12. Tighten screw (2) and adapter (3) to specified tightening torque of 100 Nm +10 Nm using a torque wrench.
13. Coat thread and sealing cone of HP fuel line with engine oil.
14. Mount HP line (5) and use torque wrench to tighten to the specified torque:
 - Injector side (4): 20 Nm +5 Nm
 - Rail side (6): 30 Nm +5 Nm
15. Fit cable connector.

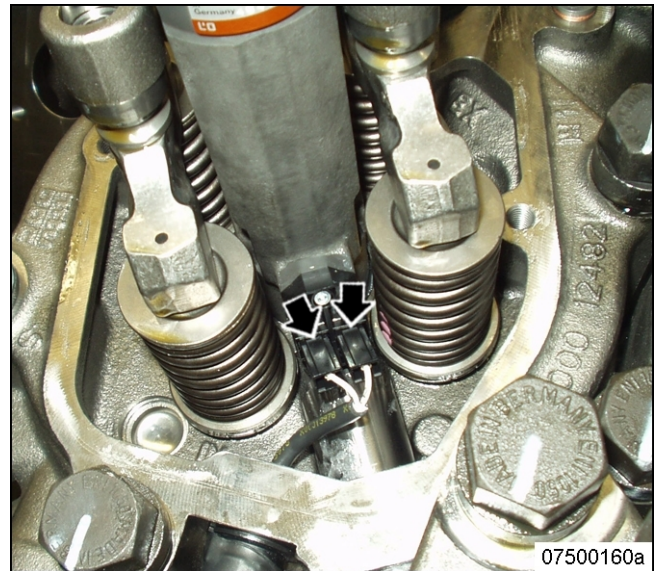
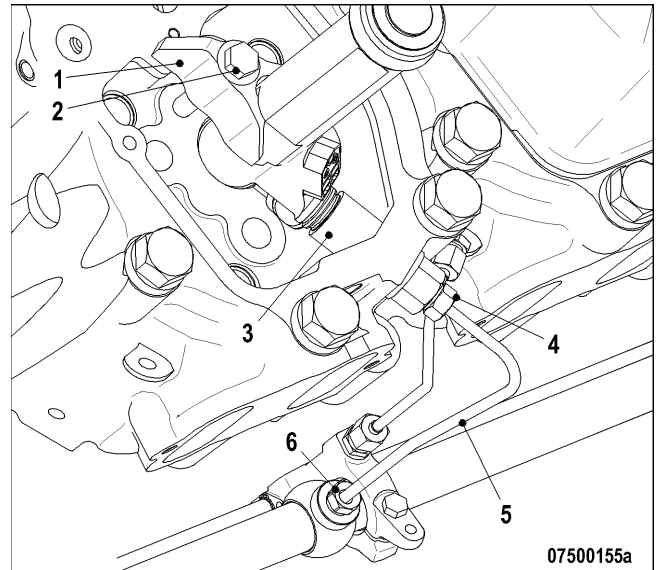

Final steps

1. Install cylinder head cover (→ Page 108).
2. Open fuel supply to engine.

6.6 Fuel System

6.6.1 Fuel system – Venting

Preconditions

- Engine is stopped and starting disabled.

Material

Designation / Use	Part No.	Qty.
Diesel fuel		



WARNING

Fuels are combustible.

Risk of fire and explosion!

- Avoid naked flames, electrical sparks and ignition sources.
- Do not smoke.

Venting LP fuel system

1. Open vent plug (1).
2. Unlock fuel priming pump (2), screw out handle by turning it counterclockwise.
3. Operate the pump with the handle (2) until bubble-free fuel emerges from the vent plug (1).
4. Close vent plug (1).
5. Screw in handle, turning it clockwise.
6. Verify that fuel priming pump (2) is locked: Handle must be tightened.

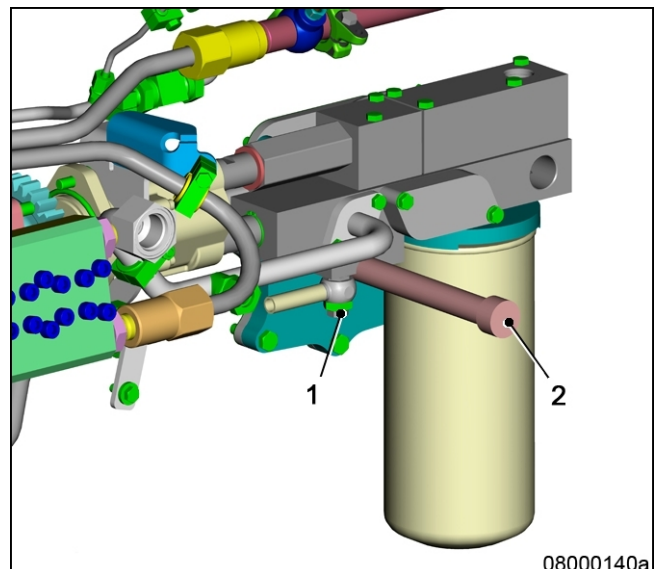

6.7 Fuel Filter

6.7.1 Fuel filter – Replacement

Preconditions

- Engine is stopped and starting disabled.

Special tools

Designation / Use	Part No.	Qty.
Filter wrench	F30379104	1

Material

Designation / Use	Part No.	Qty.
Engine oil		

Spare parts

Designation / Use	Part No.	Qty.
Easy-change filter		



WARNING

Fuels are combustible.

Risk of fire and explosion!

- Avoid naked flames, electrical sparks and ignition sources.
- Do not smoke.

Fuel filter – Replacement

1. Remove easy-change filter using filter wrench.
2. Clean the sealing surface of the filter head.
3. Slightly lubricate seal on the easy-change filter.
4. Screw on easy-change filter by hand until the seal connects and tighten manually.

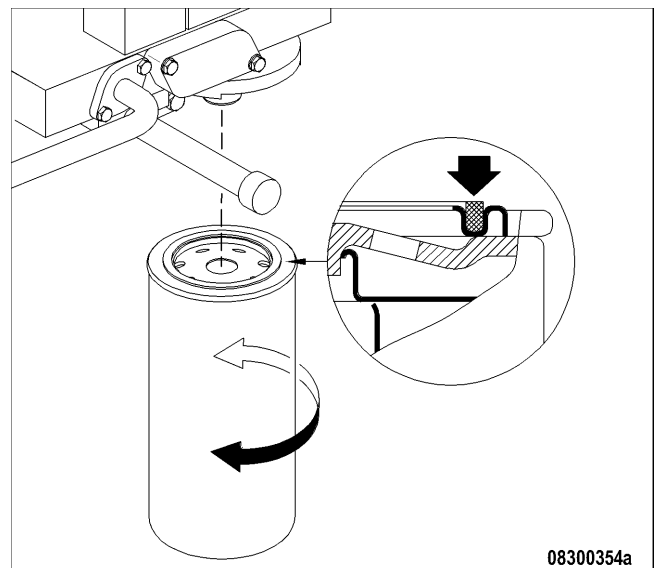

08300354a

6.7.2 Fuel prefilter cleaning

Preconditions

- Engine is stopped and starting disabled.

Material

Designation / Use	Part No.	Qty.
Diesel fuel		

Spare parts

Designation / Use	Part No.	Qty.
Sealing ring		



WARNING

Fuels are combustible.

Risk of fire and explosion!

- Avoid naked flames, electrical sparks and ignition sources.
- Do not smoke.

Fuel prefilter cleaning

1. Shut off fuel supply.
2. Remove nuts from filter head.
3. Take off filter housing and drain fuel into appropriate container.
4. Remove filter-element securing nut and remove filter element by pulling it downwards.
5. Wash filter element in clean fuel using a smooth brush.
6. Wash filter housing with clean fuel.
7. Insert filter element into filter housing and secure with nut.
8. Place new sealing ring into groove in filter head.
9. Fit cover with seal and secure it with nuts crosswise.
10. Open fuel supply.

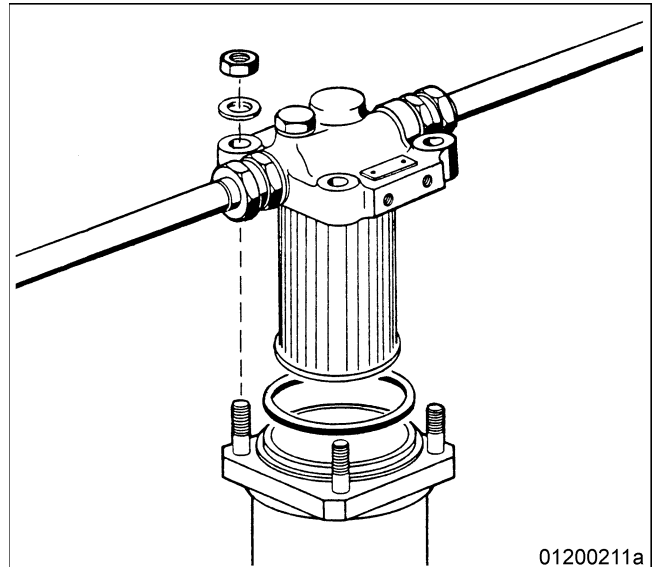

6.7.3 Fuel prefilter – differential pressure check and adjustment of gauge



Unguarded rotating and moving engine components.

Risk of serious injury – danger to life!

- Take special care when working on a running engine.



Engine noise above 85 dB (A).

Risk of damage to hearing!

- Wear ear protectors.

Setting adjustable pointer of differential pressure gauge

1. After installation of a new filter element, align adjustable pointer (2) with pressure-indicating pointer (3) of pressure gauge (1).
2. Verify that differential pressure is within the limit.

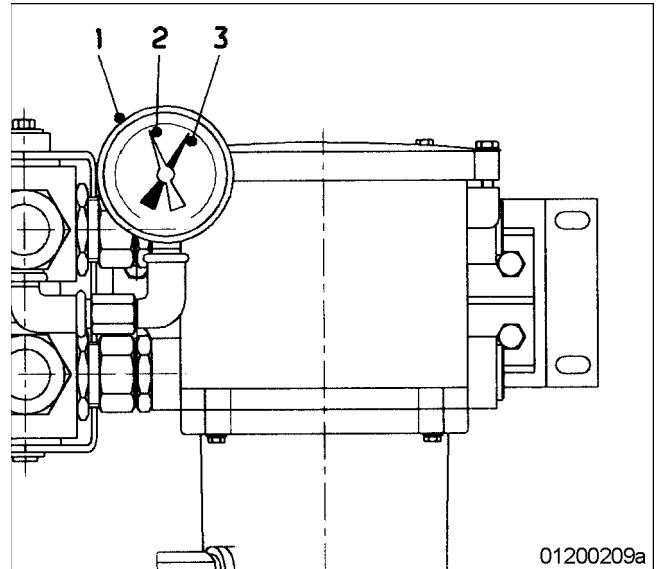

Fuel prefilter – checking differential pressure

1. With the engine running at full load or rated power, read off pressure at gauge (1).
2. If differential pressure as indicated between position of adjustable pointer (2) and pressure-indicating pointer (3) of pressure gauge is ≥ 0.3 bar, flush filter element of the cut-in filter (→ Page 120).

6.7.4 Fuel prefilter – draining

Preconditions

- Engine is stopped and starting disabled.

Material

Designation / Use	Part No.	Qty.
Diesel fuel		

Spare parts

Designation / Use	Part No.	Qty.
Gasket		



Fuels are combustible.

Risk of fire and explosion!

- Avoid naked flames, electrical sparks and ignition sources.
- Do not smoke.

Fuel prefilter – draining

1. Cut out the filter to be drained.

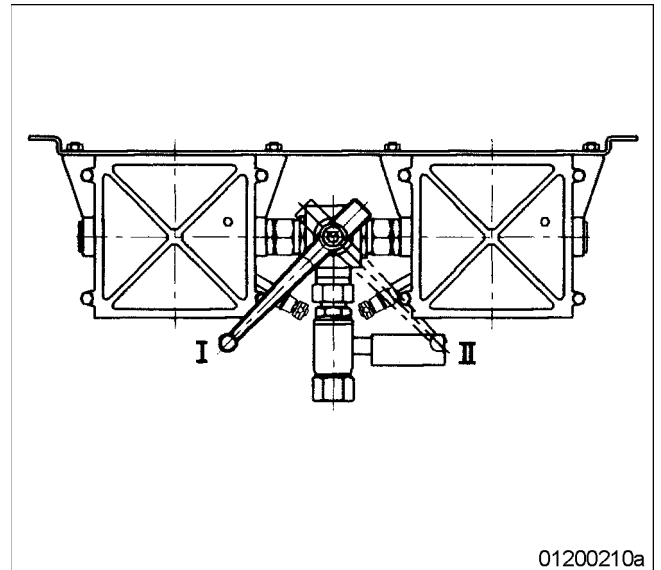

I Left filter cut in
II Right filter cut in

2. Open vent plug (5) of the filter to be drained.
3. Unlock drain cock (6) by pressing toggle and open it.
4. Drain water and contaminants from the filter until pure fuel emerges.
5. Close drain cock (6).
6. Remove screws securing the cover and take off cover (2).
7. Fill filter housing with clean fuel.
8. Place new gasket in cover (2).
9. Fit cover with gasket and secure it with screws.
10. Cut the cut-out filter in again.
11. When fuel emerges from system, close vent plug (5).

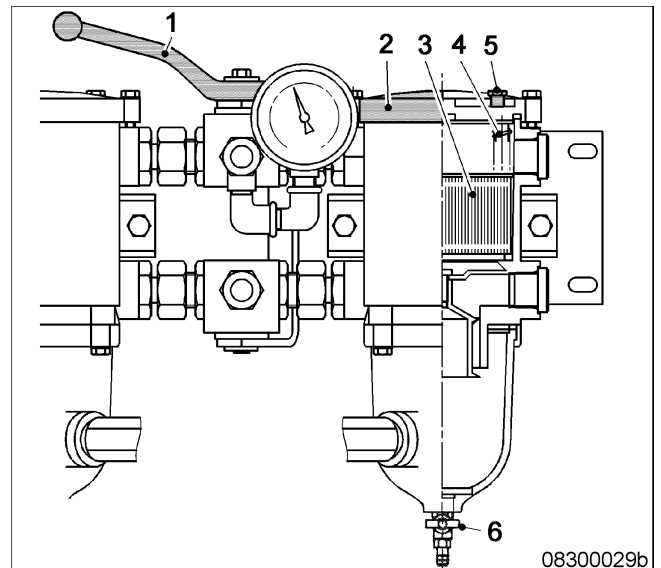

08300029b



6.7.5 Fuel prefilter – flushing

Material

Designation / Use	Part No.	Qty.
Diesel fuel		

Spare parts

Designation / Use	Part No.	Qty.
Gasket		

 DANGER	Unguarded rotating and moving engine components. Risk of serious injury – danger to life! <ul style="list-style-type: none"> • Take special care when working on a running engine.
 WARNING	Fuels are combustible. Risk of fire and explosion! <ul style="list-style-type: none"> • Avoid naked flames, electrical sparks and ignition sources. • Do not smoke.
 WARNING	Engine noise above 85 dB (A). Risk of damage to hearing! <ul style="list-style-type: none"> • Wear ear protectors.

Fuel prefilter – flushing

1. Cut out the contaminated filter.

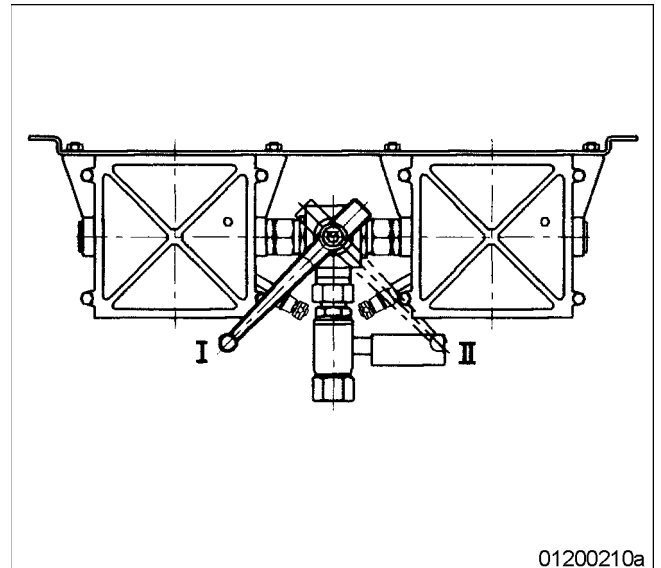

I Left filter cut in
II Right filter cut in

2. Open vent plug (5) of the filter to be flushed.
3. Unlock drain cock (6) by pressing toggle, open it and drain fuel.

Result: Fuel flows from filtered side back to the unfiltered side, flushing the filter deposits downwards out of the filter.

4. Close vent plug (5) and drain cock (6).

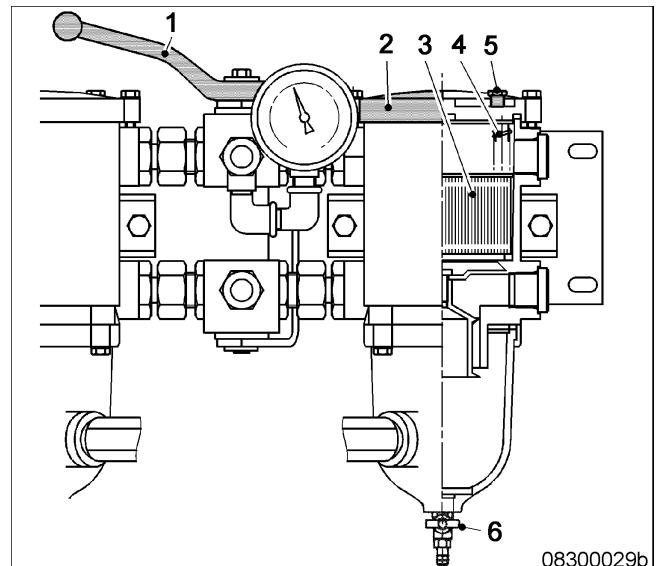

08300029b

Fuel prefilter – filling fuel

1. Stop engine (→ Page 60) and disable engine start.
2. Remove screws securing the cover and take off cover (2).
3. Fill filter housing with clean fuel.
4. Place new gasket in cover (2).
5. Fit cover with gasket and secure it with screws.
6. Check differential pressure (→ Page 117).

Result: If flushing did not lead to an improvement of the differential pressure, replace filter element (→ Page 122).

6.7.6 Fuel prefilter – filter element replacement

Preconditions

- Engine is stopped and starting disabled.

Material

Designation / Use	Part No.	Qty.
Diesel fuel		

Spare parts

Designation / Use	Part No.	Qty.
Filter element		
Gasket		



WARNING

Fuels are combustible.

Risk of fire and explosion!

- Avoid naked flames, electrical sparks and ignition sources.
- Do not smoke.

Fuel prefilter – filter element replacement

1. Cut out the contaminated filter.

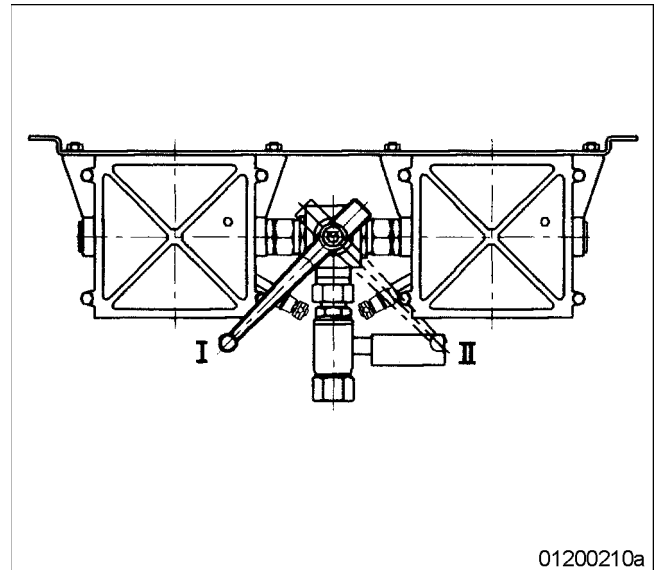

- I Left filter cut in
II Right filter cut in

2. Open vent plug (5) of the contaminated filter.
3. Unlock drain cock (6) by pressing toggle and open it.
4. Drain water and contaminants from the filter.
5. Close drain cock (6).
6. Remove screws securing the cover and take off cover (2).
7. Remove spring (4) and filter element (3).
8. Insert new filter element (3) and spring (4).
9. Fill filter housing with clean fuel.
10. Place new gasket in cover (2).
11. Fit cover with gasket and secure it with screws.
12. Cut the cut-out filter in again.
13. Close vent plug (5) when fuel emerges.
14. Align adjustable pointer of differential pressure gauge with pressure-indicating pointer.
(→ Page 117).

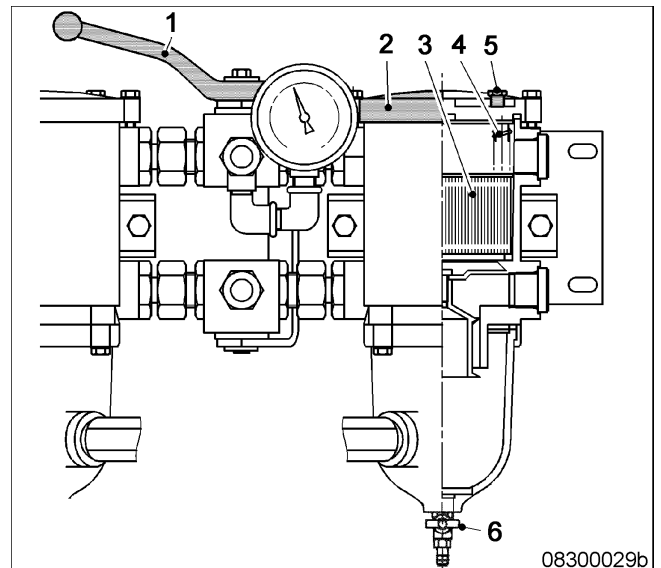

6.8 Charge-air Cooling, General, Left Side

6.8.1 Intercooler – Checking condensate drains for coolant discharge and obstructions



Unguarded rotating and moving engine components.
Risk of serious injury – danger to life!
 • Take special care when working on a running engine.



Engine noise above 85 dB (A).
Risk of damage to hearing!
 • Wear ear protectors.



Compressed air.
Risk of injury!
 • Do not direct compressed-air jet at persons.
 • Wear protective goggles / safety mask and ear protectors.

Intercooler – Checking condensate drains for coolant discharge and obstructions

1. With the engine running, verify that air emerges from the condensate drain(s) at driving end, left and right engine side.
2. Clean drain bore(s) and blow out with compressed air.
3. If a large amount of coolant is continuously discharged, the intercooler is leaking. Contact Service.

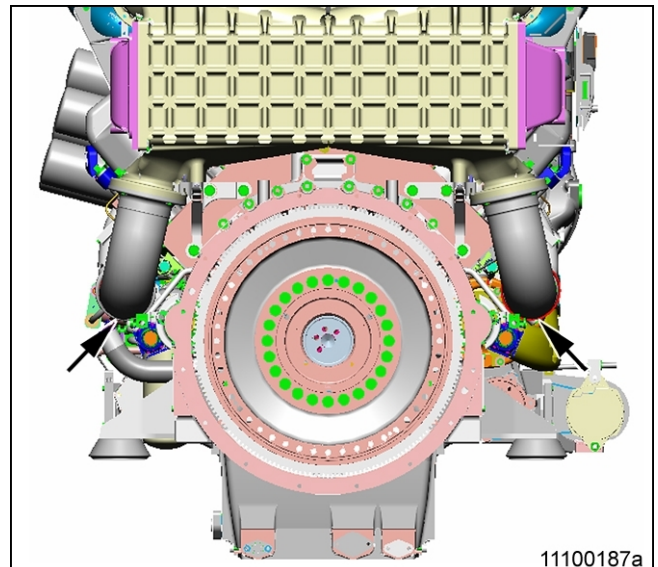

Emergency measures prior to engine start with a leaking intercooler

1. Remove injectors (→ Page 110).
2. Bar engine manually (→ Page 95).
3. Bar engine with starting system to blow out combustion chambers (→ Page 96).
4. Install injectors (→ Page 110).

6.9 Air Filter

6.9.1 Air filter replacement

Spare parts

Designation / Use	Part No.	Qty.
Air filter		

Remove air filter and install new one (→ Page 127).

Reset signal ring of service indicator (→ Page 129).

6.9.2 Air filter – Check

Spare parts

Designation / Use	Part No.	Qty.
Air filter		

Air filter – Check

1. Check entire circumference of air filter for damage.
2. Fit new air filter if damaged (→ Page 127).

6.9.3 Air filter removal and installation

Preconditions

- Engine is stopped and starting disabled.

Air filter removal and installation

1. Loosen clamp (2).
2. Remove air filter (3) and clamp (2) from flange of intake housing (1).
3. Verify that there are no objects in the flange of the intake housing (1) and clean it.
4. Place new air filter (3) with clamp (2) onto intake housing (1).
5. Tighten clamp (2).

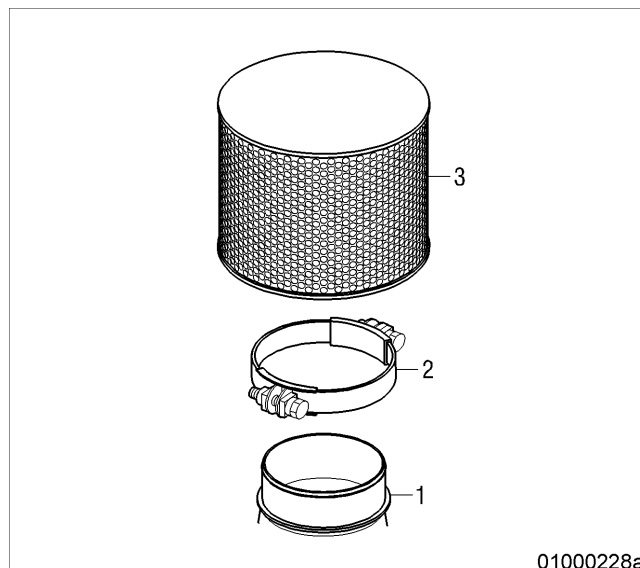

6.9.4 Rubber sleeves between air intake elbow and turbocharger – Replacement

Preconditions

- Engine is stopped and starting disabled.

Spare parts

Designation / Use	Part No.	Qty.
Rubber sleeve		4

Remove air filter (→ Page 125).

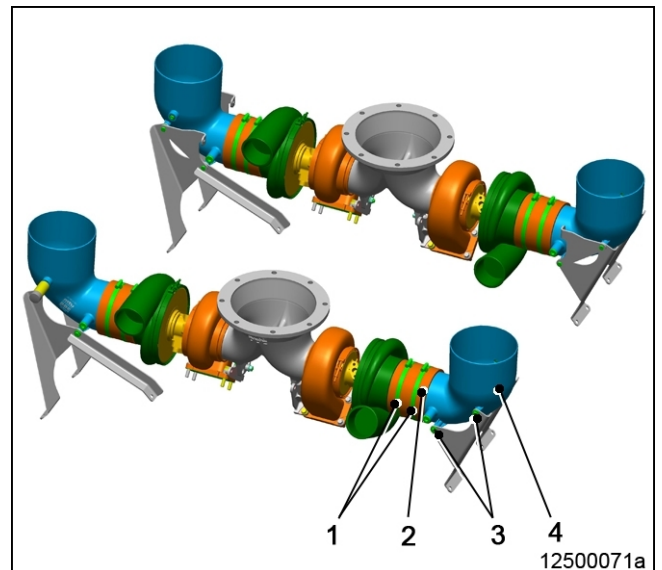

Replacing rubber sleeves

1. Remove four screws (3), loosen clamps (1) and take off elbow (4).
2. Pull off rubber sleeve (2) from turbocharger intake flange.
3. Clean connecting flange of turbocharger and check for obstructions.
4. Fit new rubber sleeve (2) on turbocharger intake flange.
5. Fit both clamps (1) on rubber sleeve (2), slide on elbow (4) and secure with screws (3).
6. Align clamps (1) and tighten.
7. Replace further rubber sleeves in the same way.

6.10 Air Intake

6.10.1 Service indicator – Signal ring position check

Preconditions

- Engine is stopped and starting disabled.

Signal ring position check

1. If the signal ring is completely visible in the control window (2), replace air filter (→ Page 125).
2. After installation of new filter, press reset button (1).

Result: Engaged piston with signal ring moves back to initial position.

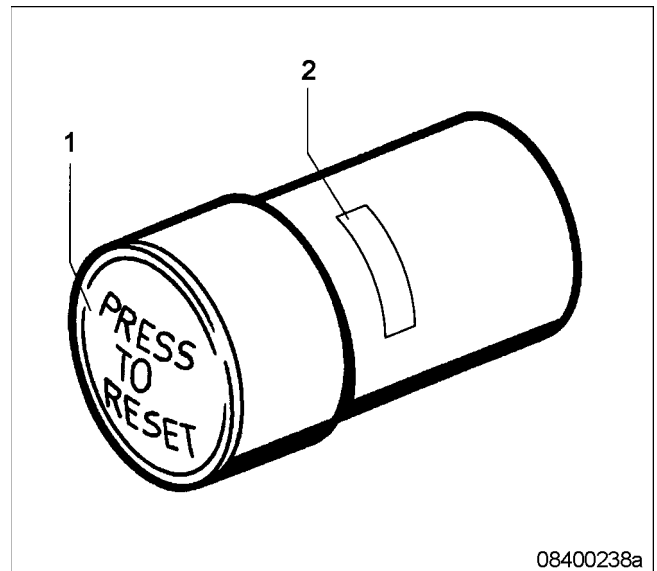

6.11 Starting Equipment

6.11.1 Air starter – manual operation



DANGER

Unguarded rotating and moving engine components.

Risk of serious injury — danger to life!

- Before barring or starting the engine, ensure that nobody is in the danger zone.



WARNING

Engine noise above 85 dB (A).

Risk of damage to hearing!

- Wear ear protectors.

Air starter – manual operation

1. Press pushbutton for manual start and hold it.
2. Allow compressed air to enter the air starter until the engine fires evenly.
3. Release pushbutton.

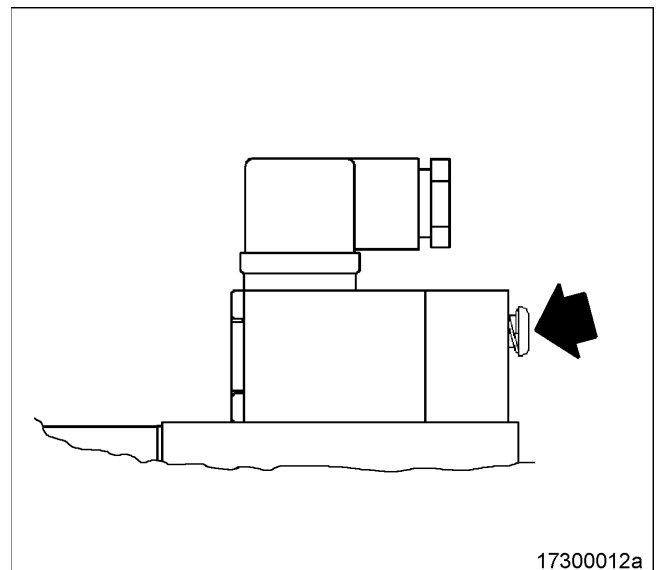

17300012a

6.11.2 Starter – Condition check

Preconditions

- Engine is stopped and starting disabled.

Starter – Condition check

1. Check starter securing screws for secure seating.
2. Tighten loose screw connections.
3. Check wiring (→ Page 155).

6.12 Lube-oil System, Lube-oil Circuit

6.12.1 Engine oil – Change

Preconditions

- Engine is stopped and starting disabled.
- Engine is at operating temperature.
- MTU Fluids and Lubricants Specification (A001061/..) is available.

Special tools

Designation / Use	Part No.	Qty.
Torque wrench	F30027337	1
Ratchet adapter	F30027341	1

Material

Designation / Use	Part No.	Qty.
Engine oil		

Spare parts

Designation / Use	Part No.	Qty.
Sealing ring		

 WARNING	<p>Hot oil. Oil can contain combustion residues which are harmful to health. Risk of injury and poisoning!</p> <ul style="list-style-type: none"> • Wear protective clothing, gloves, and goggles / safety mask. • Avoid contact with skin. • Do not inhale oil vapor.
---	--

Oil change without semirotary hand pump: Draining oil at drain plug(s) on oil pan

1. Provide a suitable container in which to collect the oil.
2. Remove drain plug(s) and drain oil.
3. Install drain plug(s) with new sealing ring.

Oil change using semirotary hand pump: Oil extraction

1. Provide a suitable container in which to collect the oil.
2. Extract all oil from oil pan using the hand pump.

Draining residual oil at equipment carrier

1. Provide a suitable container in which to collect the oil.
2. Remove drain plug (1) and drain oil (approx. 7 liters) from oil heat exchanger and oil filter.
3. Remove drain plugs (2) and (3) and drain oil:
 - at drain plug (2) approx. 12 liters
 - at drain plug (3) approx. 5 liters
4. Replace engine oil filter (→ Page 136).
5. Install drain plug(s) with new sealing ring.
6. Tighten drain plugs (2) and (3) with torque wrench to the specified torque 100 Nm +10 Nm.

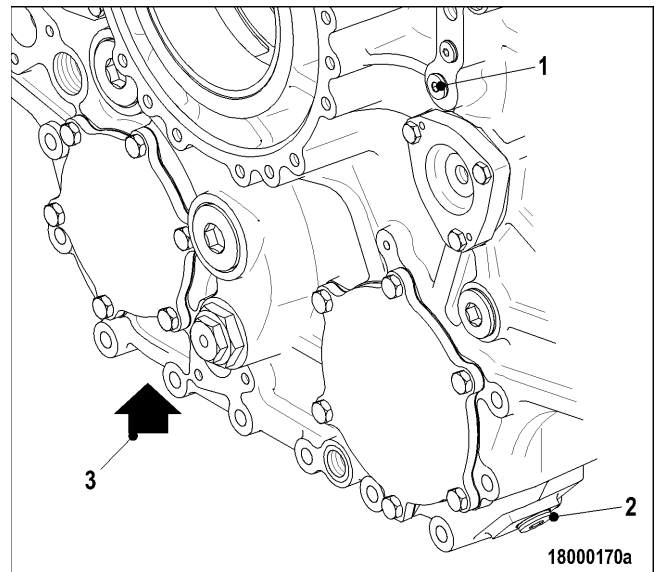

Filling with new oil

1. Open cover of filler neck.
2. Pour oil in at filler neck up to "max." mark at oil dipstick.
3. Close cover of filler neck.
4. Check engine oil level (→ Page 134).
5. After oil change and oil filter replacement, bar engine with starting system (→ Page 96).

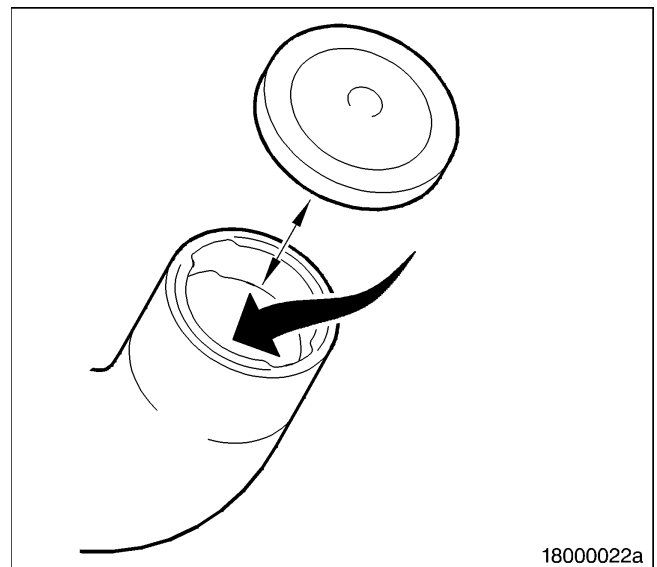

6.12.2 Engine oil – Level check

Preconditions

- Engine is stopped and starting disabled.

Checking oil level prior to engine start

1. Withdraw dipstick from guide tube and wipe it.
2. Insert dipstick into guide tube up to the stop, withdraw after approx. 10 seconds and check oil level.

Note: After extended standstill, the oil level may exceed the mark (1) by up to 2 cm. This can be caused by oil flowing from e.g. oil filter or heat exchanger back to the oil pan.

3. The oil level must reach the mark (1) or exceed the mark (1) by up to 2 cm.
4. If necessary, top up to the mark (1) (→ Page 132).
5. Insert dipstick into guide tube up to the stop.

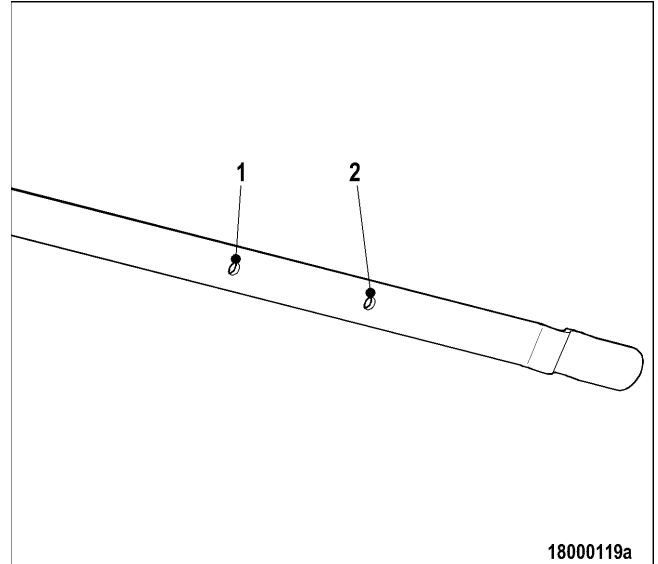

Checking oil level after the engine is stopped

1. 5 minutes after stopping the engine, remove oil dipstick from the guide tube and wipe it.
2. Insert dipstick into guide tube up to the stop, withdraw after approx. 10 seconds and check oil level.
3. Oil level must be between marks (1) and (2).
4. If necessary, top up to the mark (1) (→ Page 132).
5. Insert dipstick into guide tube up to the stop.



6.12.3 Engine oil – Sample extraction and analysis

Preconditions

- MTU Fluids and Lubricants Specifications (A001061/..) are available.

Special tools

Designation / Use	Part No.	Qty.
MTU test kit	5605892099/00	1

 DANGER	Unguarded rotating and moving engine components. Risk of serious injury – danger to life! <ul style="list-style-type: none"> • Take special care when working on a running engine.
 WARNING	Hot oil. Oil can contain combustion residues which are harmful to health. Risk of injury and poisoning! <ul style="list-style-type: none"> • Wear protective clothing, gloves, and goggles / safety mask. • Avoid contact with skin. • Do not inhale oil vapor.
 WARNING	Engine noise above 85 dB (A). Risk of damage to hearing! <ul style="list-style-type: none"> • Wear ear protectors.

Engine oil – Sample extraction and analysis

1. With the engine running at operating temperature, open screw on centrifugal oil filter carrier by 1 to 2 rotations.
2. Drain approx. 2 liters engine oil to flush out the oil sludge.
3. Drain approx. 1 liter engine oil into a clean container.
4. Close screw.
5. Using the equipment and chemicals of the MTU test kit, examine the engine oil for:
 - Dispersion capability (spot test);
 - Water content;
 - Dilution by fuel.

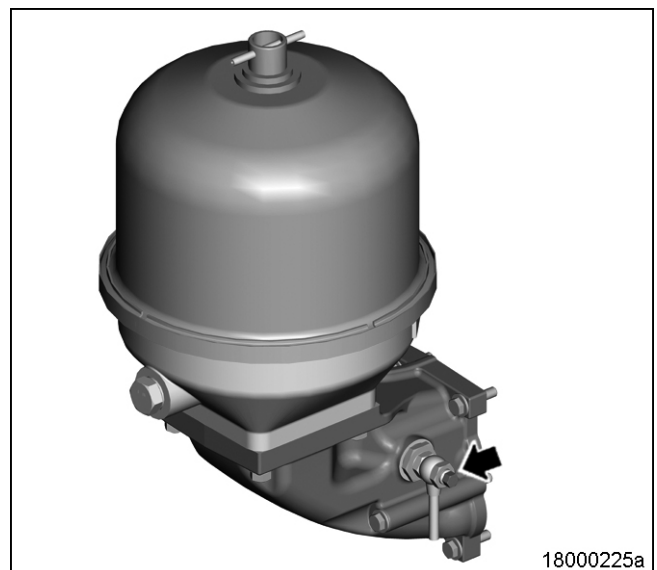

6.13 Oil Filtration/Cooling

6.13.1 Engine oil filter – Replacement

Preconditions

- Engine is stopped and starting disabled.

Special tools

Designation / Use	Part No.	Qty.
Filter wrench	F30379104	

Material

Designation / Use	Part No.	Qty.
Engine oil		

Spare parts

Designation / Use	Part No.	Qty.
Oil filter		



WARNING

Hot oil.

Oil can contain combustion residues which are harmful to health.

Risk of injury and poisoning!

- Wear protective clothing, gloves, and goggles / safety mask.
- Avoid contact with skin.
- Do not inhale oil vapor.

Engine oil filter – Replacement

1. Remove oil filter using the filter wrench.
2. Clean the sealing surface of the filter head.
3. Check condition of the new sealing ring and coat it with oil.
4. Screw on and tighten new oil filter by hand.
5. Replace further oil filters in the same way.
6. After each oil change and filter replacement, bar engine with starting system (→ Page 96).
7. Check oil level (→ Page 134).

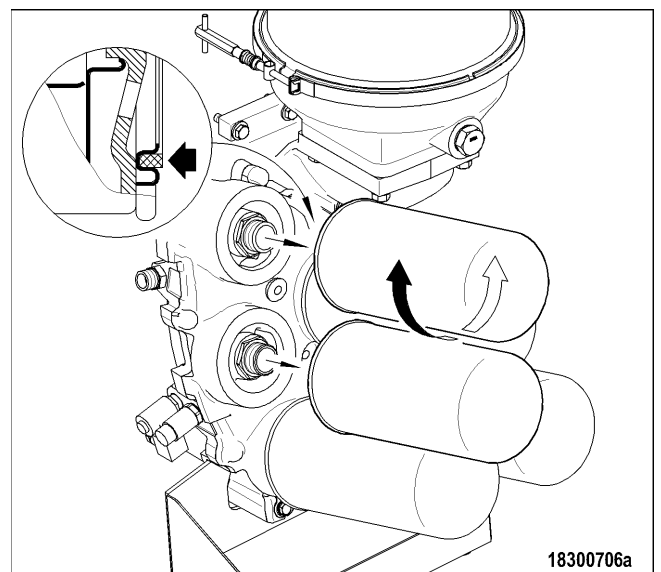

6.13.2 Centrifugal oil filter – Cleaning and filter-sleeve replacement

Preconditions

- Engine is stopped and starting disabled.

Special tools

Designation / Use	Part No.	Qty.
Torque wrench 6-50 Nm	F30027336	1

Material

Designation / Use	Part No.	Qty.
Cleaner Hakutex 60		

Spare parts

Designation / Use	Part No.	Qty.
Filter sleeve		
Sealing ring		
Sealing ring		



WARNING

Hot oil.

Oil can contain combustion residues which are harmful to health.

Risk of injury and poisoning!

- Wear protective clothing, gloves, and goggles / safety mask.
- Avoid contact with skin.
- Do not inhale oil vapor.



WARNING

Compressed air.

Risk of injury!

- Do not direct compressed-air jet at persons.
- Wear protective goggles / safety mask and ear protectors.

Centrifugal oil filter – Cleaning and filter-sleeve replacement

1. Remove clamp (3).
2. Release Tommy nut (1) and take off cover (2).
3. Carefully lift rotor (6), allow oil to drain and remove from housing.
4. Holding the rotor (6) firmly, release rotor cover nut (7).
5. Take off rotor cover (8).
6. Remove filter sleeve (10).
7. Measure thickness of oil residues on filter sleeve (10).
8. If maximum layer thickness of oil residues exceeds 45 mm, shorten maintenance interval.
9. Disassemble rotor tube (11), conical disk (12) and rotor base (14).
10. Wash rotor cover (8), rotor tube (11), conical disk (12) and rotor base (14) with cleaner.
11. Blow out with compressed air.
12. Check sealing ring (13), fit new one if necessary.
13. Assemble rotor tube (11), conical disk (12) and rotor base (14) with sealing ring (13).
14. Insert new filter sleeve (10) in rotor tube (11) with the smooth paper surface facing the wall.
15. Check sealing ring (9), fit new one if necessary.
16. Mount rotor cover (8) with sealing ring (9).
17. Tighten rotor cover nut (7) with 35 Nm to 45 Nm.
18. Place rotor (6) in housing (5) and check for ease of movement.
19. Check sealing ring (4), fit new one if necessary.
20. Fit sealing ring (4) on housing (5).
21. Fit cover (2).
22. Tighten Tommy nut (1) by hand.
23. Fit clamp (3) and tighten with 8 Nm to 10 Nm.
24. Tighten cover nut (1) with 5 Nm to 7 Nm.

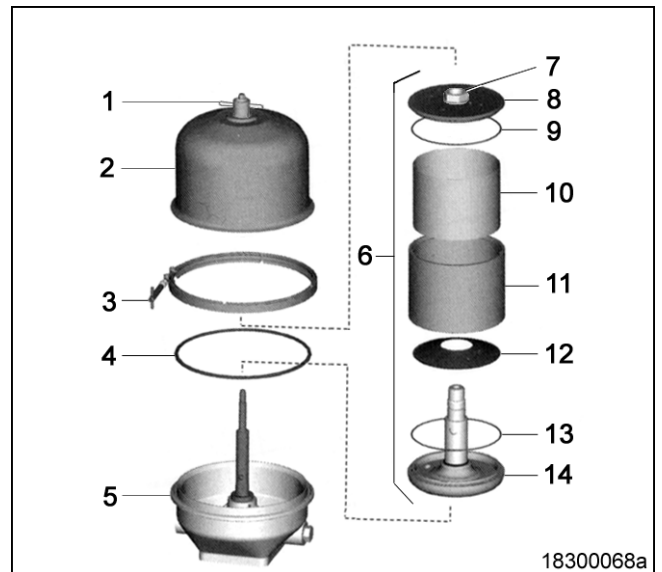

18300068a

6.14 Cooling Circuit, General, HT Circuit

6.14.1 Engine coolant – Change

Material

Designation / Use	Part No.	Qty.
Engine coolant		

Drain engine coolant (→ Page 142).

Fill engine coolant system (→ Page 140).

6.14.2 Engine coolant – Filling

Preconditions

- Engine is stopped and starting disabled.
- MTU Fluids and Lubricants Specifications (A001061/..) are available.

Material

Designation / Use	Part No.	Qty.
Engine coolant		

 WARNING	Coolant is hot and under pressure. Risk of injury and scalding! <ul style="list-style-type: none"> • Let the engine cool down. • Wear protective clothing, gloves, and goggles / safety mask.
---	---

 CAUTION	Cold coolant in hot engine can cause thermal stress. Formation of cracks in components! <ul style="list-style-type: none"> • Fill / top up coolant only into cold engine.
---	--

Preparatory steps

1. Turn breather valve of filler neck on coolant expansion tank counterclockwise to first stop and allow pressure to escape.
2. Continue to turn breather valve counterclockwise and remove.

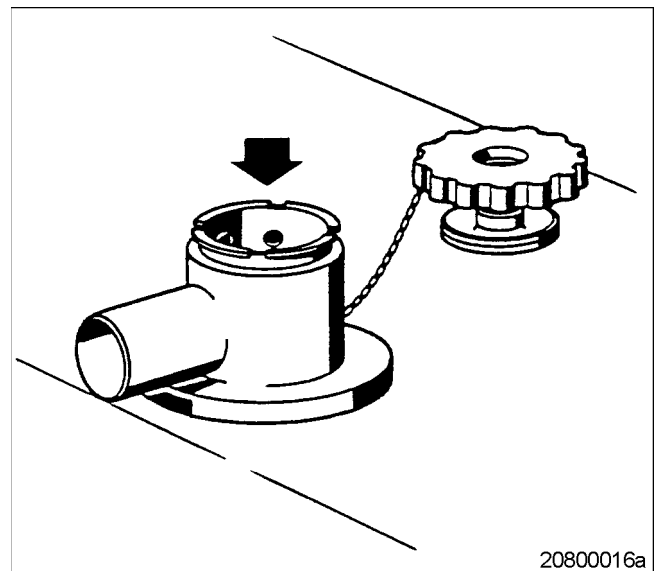

Filling coolant with pump

1. Connect appropriate pump with hose to drain valve.
2. Open drain valve and pump coolant into engine at 0.5 bar minimum.
3. Fill expansion tank until overflow edge is reached.
4. Close drain valve.
5. Check proper condition of breather valve, clean sealing faces if required.
6. Set breather valve onto filler neck and close it.
7. Start engine (→ Page 57).
8. After the engine has run at unloaded condition for 10 seconds, stop engine (→ Page 60).
9. Turn breather valve of filler neck on coolant expansion tank counterclockwise to first stop and allow pressure to escape.
10. Continue to turn breather valve counterclockwise and remove.
11. Check coolant level (→ Page 143) and top up if required:
 - 11.1. Fill in coolant in expansion tank until the coolant level at top edge of filler neck remains constant.
 - 11.2. Set breather valve onto filler neck and close it.
 - 11.3. Repeat the steps from "Start engine" → 7. until coolant is no longer needed to be topped up.
 - 11.4. Disconnect pump and hose.

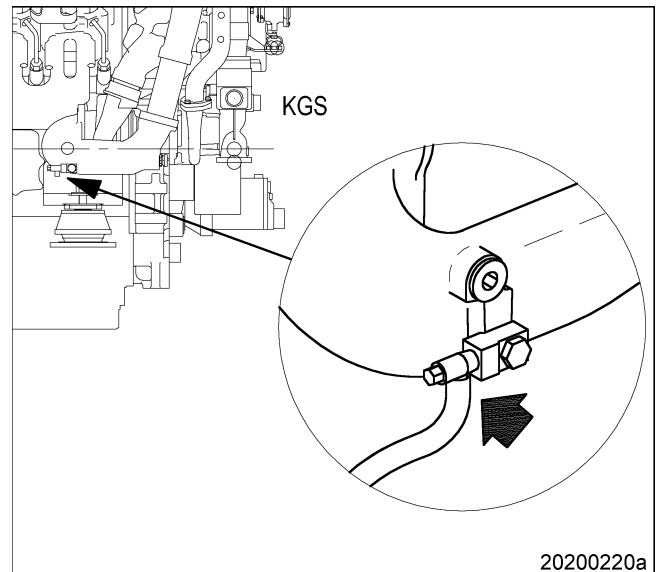

20200220a

Filling coolant through filler neck

1. Alternatively: Fill in coolant in expansion tank until the coolant level at top edge of filler neck remains constant.
2. Check proper condition of breather valve, clean sealing faces if required.
3. Set breather valve onto filler neck and close until first stop is reached.
4. Start engine (→ Page 57).
5. After the engine has run at unloaded condition for 10 seconds, stop engine (→ Page 60).
6. Turn breather valve counterclockwise and remove.
7. Check coolant level (→ Page 143) and top up if required:
 - 7.1. Repeat the steps from "Start engine" → 4. until coolant is no longer needed to be topped up.
 - 7.2. Check proper condition of breather valve, clean sealing faces if required.
 - 7.3. Set breather valve onto filler neck and close it.

Final steps

1. Start the engine and operate it at unloaded condition for some minutes.
2. Check coolant level (→ Page 143) and top up if required.

6.14.3 Engine coolant – Draining

Preconditions

- Engine is stopped and starting disabled.



Coolant is hot and under pressure.

Risk of injury and scalding!

- Let the engine cool down.
- Wear protective clothing, gloves, and goggles / safety mask.

Preparatory steps

1. Provide an appropriate container to drain the coolant into.
2. Switch off preheating unit.

Engine coolant – Draining

1. Turn breather valve of coolant expansion tank counterclockwise until the first stop and allow pressure to escape.
2. Continue to turn breather valve counterclockwise and remove.
3. Draw off segregated corrosion inhibitor oil in expansion tank through the filler neck.
4. Open drain cocks or drain plugs and drain coolant at the following points:
 - Preheating unit;
 - Thermostat housing (arrow)
 - U-bend (arrow)
 - HT coolant pump elbow;
 - Crankcase, left and right side.
5. Close all open drain points.
6. Place breather valve on filler neck and close.

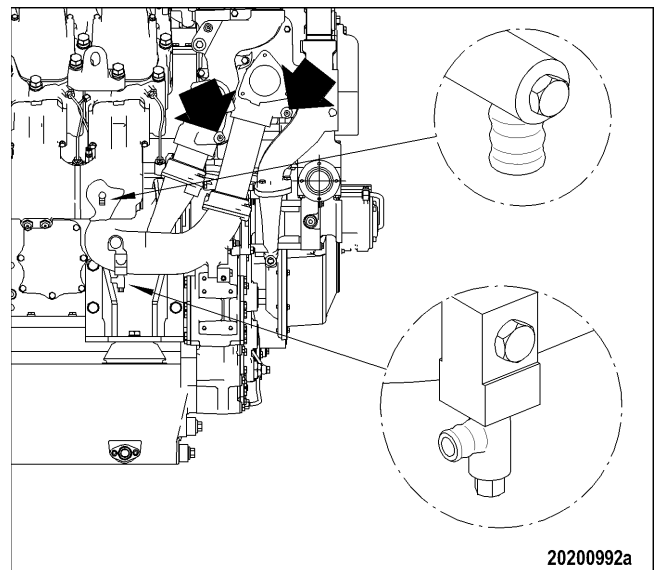

20200992a

6.14.4 Engine coolant level – Check

Preconditions

- Engine is stopped and starting disabled.
- MTU Fluids and Lubricants Specification (A001061/..) is available.



Coolant is hot and under pressure.

Risk of injury and scalding!

- Let the engine cool down.
- Wear protective clothing, gloves, and goggles / safety mask.

Coolant-level check at filler neck:

1. Turn breather valve of filler neck on coolant expansion tank counterclockwise to first stop and allow pressure to escape.
2. Continue to turn breather valve counterclockwise and remove.
3. Check coolant level (coolant must be visible at the lower edge of the cast-in eye).

Coolant-level check at external cooler:

1. Check coolant level (coolant must be visible at marking plate).
2. If required, top up with treated coolant (→ Page 140).
3. Check and clean breather valve.
4. Set breather valve onto filler neck and close it.

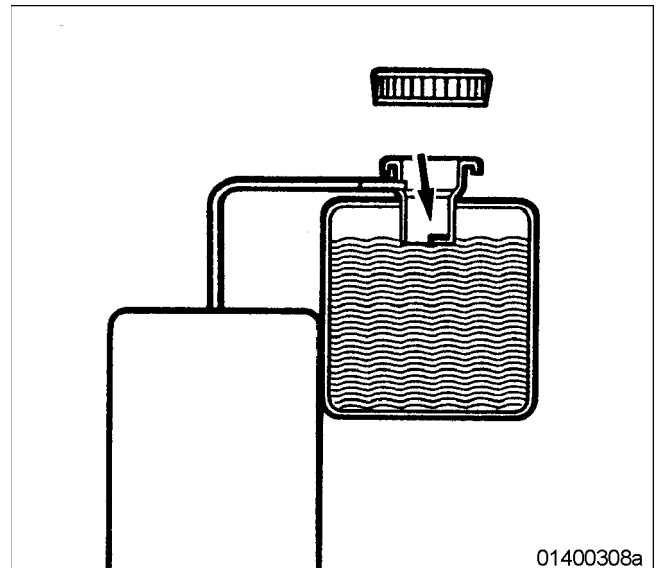

Coolant-level check by means of level sensor:

1. Switch on engine control system and check readings on the display.
2. If required, top up with treated coolant (→ Page 140).

6.14.5 Engine coolant pump – Relief bore check



Unguarded rotating and moving engine components.

Risk of serious injury – danger to life!

- Take special care when working on a running engine.



Engine noise above 85 dB (A).

Risk of damage to hearing!

- Wear ear protectors.

Engine coolant pump – Relief bore check

1. Check relief bore for oil and water discharge.
2. Stop the engine (→ Page 60) and disable engine start, observe general safety instructions.
3. Clean the relief bore with a wire if it is dirty.
 - Permissible coolant discharge: up to 10 drops per hour;
 - Permissible oil discharge: up to 5 drops/hour;
4. If discharge exceeds the specified limits: Contact Service.

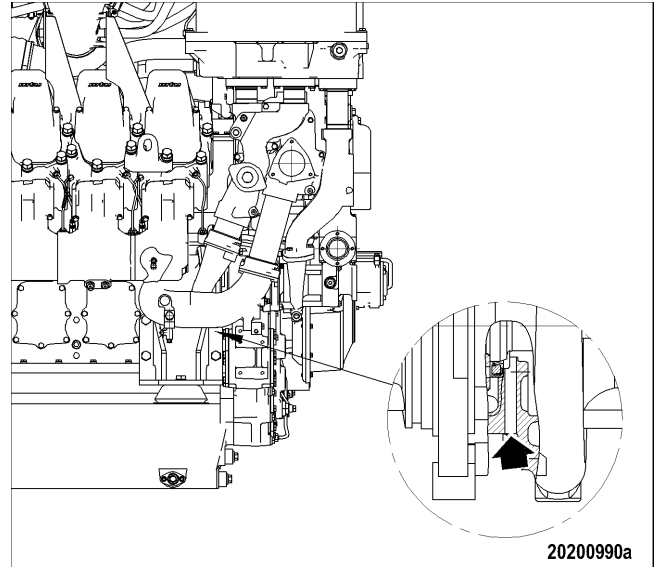



6.14.6 Engine coolant – Sample extraction and analysis

Preconditions

- MTU Fluids and Lubricants Specification (A001061/..) is available.

Special tools

Designation / Use	Part No.	Qty.
MTU test kit	5605892099/00	1

 DANGER	Unguarded rotating and moving engine components. Risk of serious injury – danger to life! <ul style="list-style-type: none"> • Take special care when working on a running engine.
 WARNING	Coolant is hot and under pressure. Risk of injury and scalding! <ul style="list-style-type: none"> • Let the engine cool down. • Wear protective clothing, gloves, and goggles / safety mask.
 WARNING	Engine noise above 85 dB (A). Risk of damage to hearing! <ul style="list-style-type: none"> • Wear ear protectors.

Engine coolant – Sample extraction and analysis

1. With the engine running, open drain valve.
2. Flush sample-extraction point by draining approx. 1 liter coolant.
3. Drain approx. 1 liter coolant into a clean container.
4. Close drain valve.
5. Using the equipment and chemicals of the MTU test kit, examine coolant for:
 - antifreeze concentration;
 - corrosion inhibitor concentration;
 - pH value.
6. For engine coolant change intervals (→MTU Fluids and Lubricants Specifications).

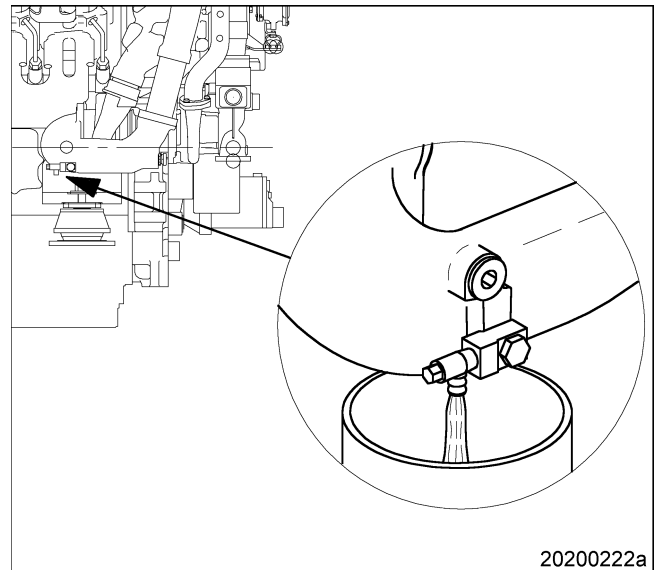

20200222a

6.15 LT Circuit

6.15.1 Charge-air coolant change

Material

Designation / Use	Part No.	Qty.
Coolant		

Drain charge-air coolant system (→ Page 149).

Fill charge-air coolant system (→ Page 147).

6.15.2 Charge-air coolant – Filling

Preconditions

- Engine is stopped and starting disabled.
- MTU Fluids and Lubricants Specifications (A001061/..) are available.

Material

Designation / Use	Part No.	Qty.
Charge-air coolant		



Coolant is hot and under pressure.

Risk of injury and scalding!

- Let the engine cool down.
- Wear protective clothing, gloves, and goggles / safety mask.



Cold coolant in hot engine can cause thermal stress.

Formation of cracks in components!

- Fill / top up coolant only into cold engine.

Preparatory steps

1. Turn breather valve of coolant expansion tank counterclockwise until the first stop and allow pressure to escape.
2. Continue to turn breather valve counterclockwise and remove.

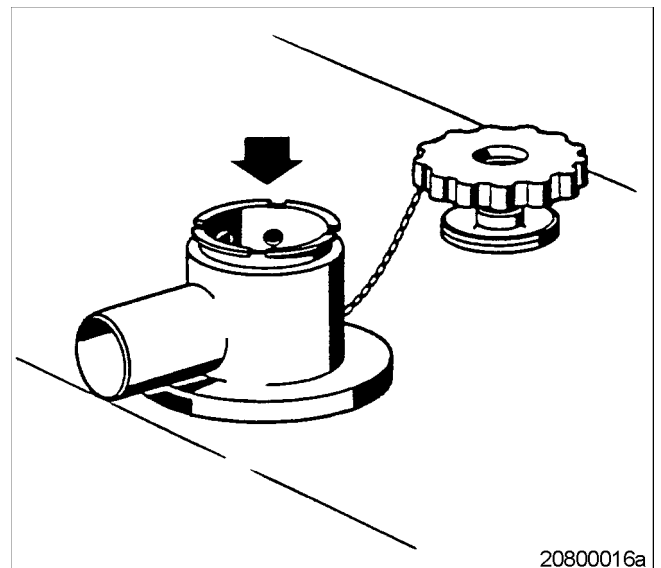

Filling with charge-air coolant using pump

1. Connect a suitable pump with a hose to the drain valve (arrow).
2. Open drain valve and pump coolant into engine at 0.5 bar minimum.
3. Fill expansion tank until overflow edge is reached.
4. Close drain valve.
5. Check proper condition of breather valve and clean sealing faces if required.
6. Place breather valve on filler neck and close.
7. Start engine (→ Page 57).
8. After the engine has run at unloaded condition for 10 seconds, stop engine (→ Page 60).
9. Turn breather valve of coolant expansion tank counterclockwise until the first stop and allow pressure to escape.
10. Continue to turn breather valve counterclockwise and remove.
11. Check coolant level (→ Page 150) and top up if required:
 - 11.1. Fill in coolant in expansion tank until the coolant level at top edge of filler neck remains constant.
 - 11.2. Place breather valve on filler neck and close.
 - 11.3. Repeat the steps from "Start engine" → 7. until coolant is no longer needed to be topped up.
 - 11.4. Disconnect pump and hose.

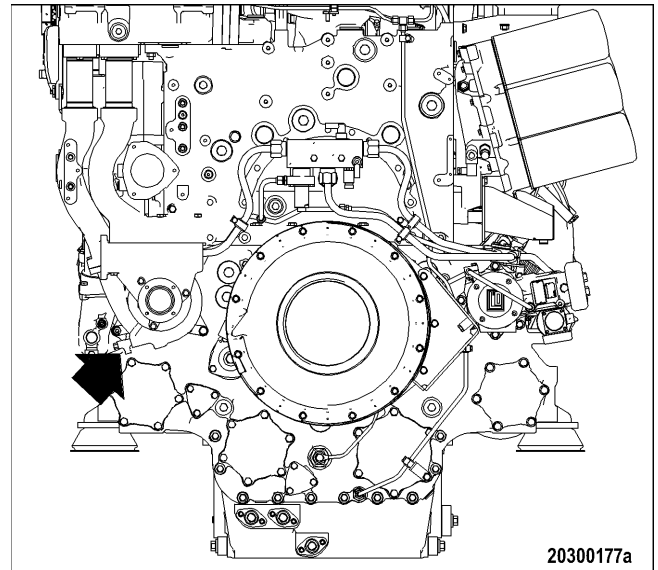

Filling coolant through filler neck

1. Alternatively: Fill in coolant in expansion tank until the coolant level at top edge of filler neck remains constant.
2. Check proper condition of breather valve and clean sealing faces if required.
3. Set breather valve onto filler neck and close until first stop is reached.
4. Start engine (→ Page 57).
5. After the engine has run at unloaded condition for 10 seconds, stop engine (→ Page 60).
6. Turn breather valve counterclockwise and remove.
7. Check coolant level (→ Page 150) and top up if required:
 - 7.1. Repeat the steps from "Start engine" → 4. until coolant is no longer needed to be topped up.
 - 7.2. Check proper condition of breather valve and clean sealing faces if required.
 - 7.3. Place breather valve on filler neck and close.

Final steps

1. Start the engine and operate it at unloaded condition for some minutes.
2. Check coolant level (→ Page 150) and top up if required.

6.15.3 Charge-air coolant – Draining

Preconditions

- Engine is stopped and starting disabled.

Spare parts

Designation / Use	Part No.	Qty.
Sealing ring		

 WARNING	Coolant is hot and under pressure. Risk of injury and scalding! <ul style="list-style-type: none"> • Let the engine cool down. • Wear protective clothing, gloves, and goggles / safety mask.
---	---

Charge-air coolant – Draining

1. Provide an appropriate container to drain the coolant into.
2. Turn breather valve of coolant expansion tank counterclockwise until the first stop and allow pressure to escape.
3. Continue to turn breather valve counterclockwise and remove.
4. Draw off segregated corrosion inhibitor oil in expansion tank through the filler neck.
5. Open drain valves and drain plugs and drain coolant at the following points:
 - at the LT coolant pump
 - at the LT thermostat housing.

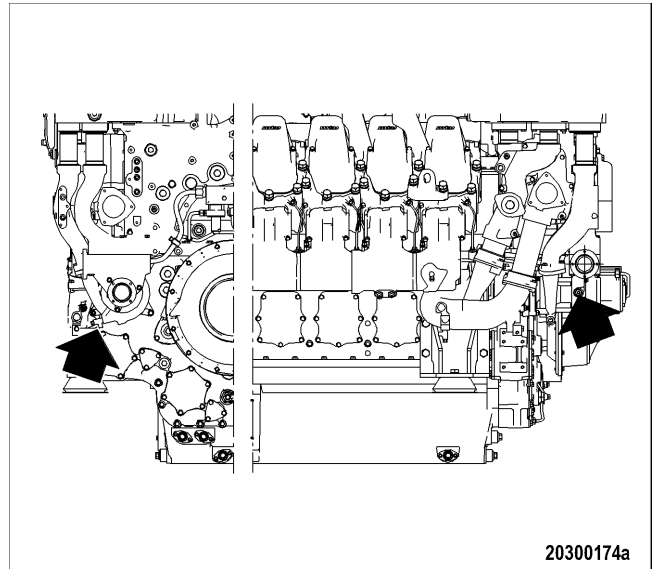

6. Draining of residual coolant:
 - at the intercooler
7. Close all drain valves and install drain plugs with new sealing rings.
8. Place breather valve on filler neck and close.

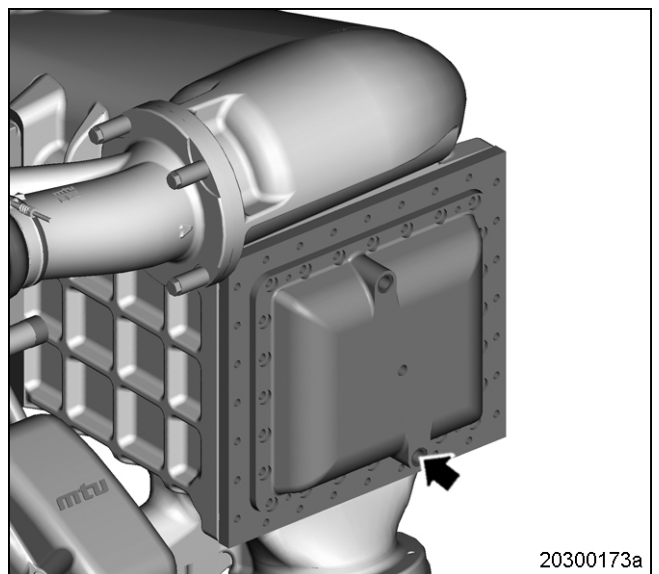

6.15.4 Charge-air coolant level check

Preconditions

- Engine is stopped and starting disabled.
- MTU Fluids and Lubricants Specification (A001061/..) is available.



Coolant is hot and under pressure.

Risk of injury and scalding!

- Let the engine cool down.
- Wear protective clothing, gloves, and goggles / safety mask.

Charge-air coolant level check at filler neck:

1. Turn breather valve of filler neck on coolant expansion tank counterclockwise to first stop and allow pressure to escape.
2. Continue to turn breather valve counterclockwise and remove.
3. Check coolant level (coolant must be visible at marking plate).
4. If required, top up with treated coolant (→ Page 147).
5. Check proper condition of breather valve, clean sealing faces if required.
6. Fit breather valve onto filler neck and close it.

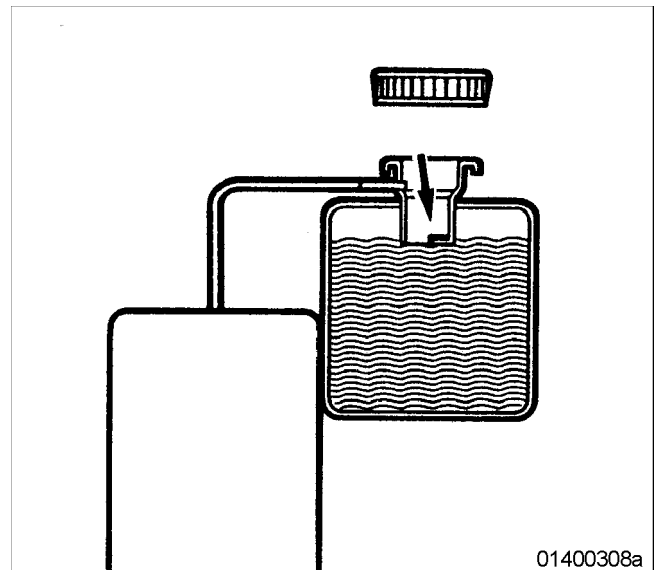

Charge-air coolant level check by means of level sensor:

1. Switch engine control system ON and check display (coolant level is automatically monitored by the engine control system).
2. If required, top up with treated coolant (→ Page 147).

6.15.5 Charge-air coolant pump – Relief bore check



Unguarded rotating and moving engine components.

Risk of serious injury – danger to life!

- Take special care when working on a running engine.



Engine noise above 85 dB (A).

Risk of damage to hearing!

- Wear ear protectors.

Charge-air coolant pump – Relief bore check

1. Check relief bore for oil and water discharge.
2. Stop the engine (→ Page 60) and disable engine start, observe general safety instructions.
3. Clean the relief bore with a wire if it is dirty.
 - Permissible coolant discharge: up to 10 drops per hour;
 - Permissible oil discharge: up to 5 drops per hour;
4. If discharge exceeds the specified limits: Contact Service.

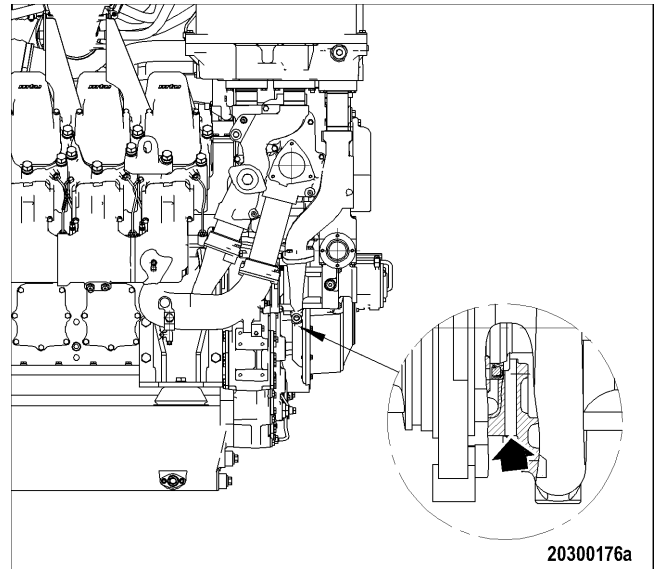

6.16 Belt Drive

6.16.1 Drive belt – Condition check

Preconditions

- Engine is stopped and starting disabled.
- Guard is removed.

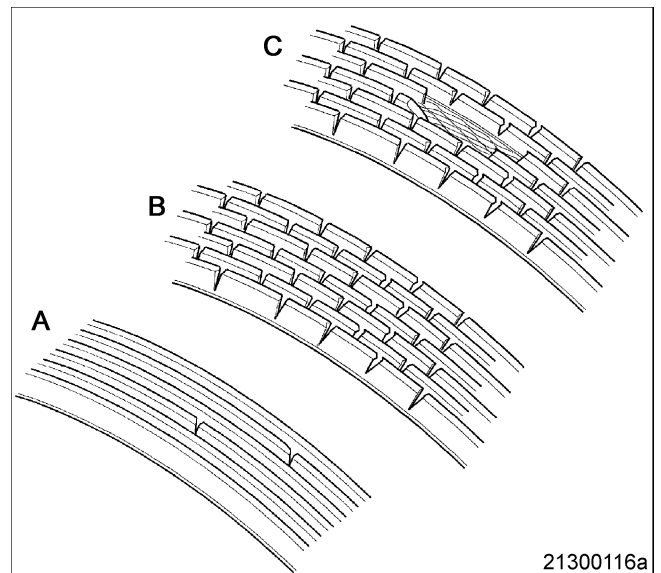

Item	Findings	Task
Drive belt A	Breaks in a few individual places	None
Drive belt	Belt is oily, shows signs of overheating	Replace (→ Page 154)
Drive belt B	Breaks around the entire circumference	
Drive belt C	Areas of belt material missing	

6.17 Battery-charging Generator

6.17.1 Battery-charging generator drive – Drive belt tension adjustment

Preconditions

- Engine is stopped and starting disabled.



Spring/circlip/tensioning roller preload.

Risk of injury!

- Only use specified tool and equipment.

Adjusting belt tension

1. Remove guard cover.
2. Slacken screws (1) and (2) by half a turn.
Result: Belt tensioner moves against the drive belt and tensions it.
3. Use torque wrench to tighten screw (1) to the specified torque 42 Nm and screw (2) to 60 Nm up to 65 Nm.
4. Install guard cover.

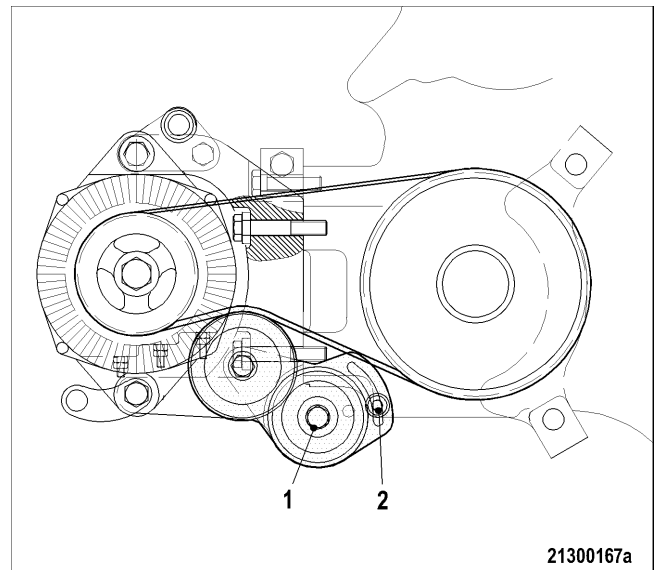

6.17.2 Battery-charging generator drive – Drive belt replacement

Preconditions

- Engine is stopped and starting disabled.

Spare parts

Designation / Use	Part No.	Qty.
Drive belt		



WARNING

Spring/circlip/tensioning roller preload.

Risk of injury!

- Only use specified tool and equipment.

Battery-charging generator drive – Drive belt replacement

1. Remove guard cover.
2. Slacken screws (1) and (2) by half a turn.
3. Place socket adapter or box wrench on screw (3) and press belt tensioner in the direction indicated by the arrow as far as it will go.
4. Tighten screw (2).
5. Remove the used drive belt.
6. Fit new drive belt.
7. Slacken screw (2) by half a turn.
Result: Belt tensioner moves against the drive belt and tensions it.
8. Use torque wrench to tighten screw (1) to the specified torque 42 Nm and screw (2) to 60 Nm up to 65 Nm.
9. Install guard cover.
10. Readjust belt tension after 30 minutes and again after 8 hours engine runtime. (→ Page 153)

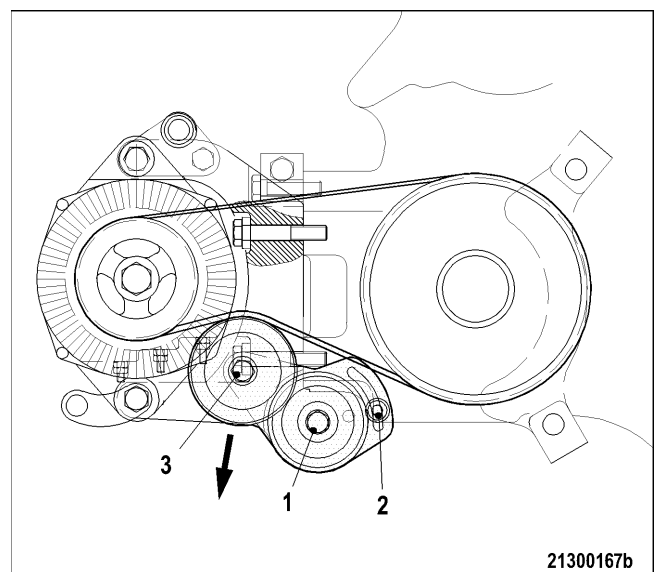

6.18 Cabling, General for Engine / Gearbox / Plant

6.18.1 Engine wiring – Check

Preconditions

- Engine is stopped and starting disabled.

Material

Designation / Use	Part No.	Qty.
Isopropyl alcohol	46181	1

Engine wiring – Check

1. Check securing screws of cable clamps on the engine and tighten loose screw connections.
2. Make certain that cables are securely seated in clamps and cannot move freely.
3. Check cable binders for secure seating, tighten loose cable binders.
4. Replace defective cable binders.
5. Inspect electrical components visually for damage:
 - connector housings;
 - contacts;
 - connector sockets;
 - cables and terminals;
 - plug-in contacts.
6. If conductors are damaged, (→Contact Service).
7. Clean dirty connector housings, sockets and contacts with isopropyl alcohol.

6.19 Accessories for Engine Governor (Electronic) / Control System

6.19.1 ECU and connectors – Cleaning

Preconditions

- Engine is stopped and starting disabled.

Material

Designation / Use	Part No.	Qty.
Isopropyl alcohol		

ECU and connectors – Cleaning

1. Remove coarse dirt from housing surface using a cloth moistened with isopropyl alcohol.
2. Remove dirt from connector and cable surfaces with isopropyl alcohol.
3. Check legibility of cable labels. Clean or replace illegible labels.

Cleaning severely contaminated connectors on ECU

1. Release latches of connectors and withdraw connectors.
2. Clean connector housings, connector socket housings and all contacts with isopropyl alcohol.
3. When connectors, sockets and all contacts are dry: Fit connectors and secure latches.

6.19.2 ECU – Checking plug-in connections

Preconditions

- Engine is stopped and starting disabled.

ECU – Checking plug-in connections



1. Verify that all plug-in connections are securely seated.
2. Secure loose connectors and latch.

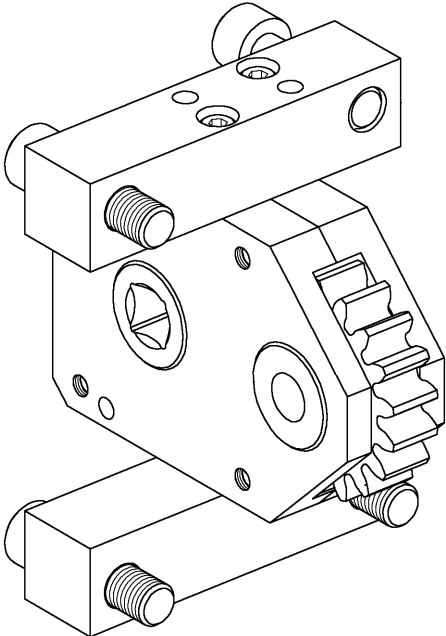
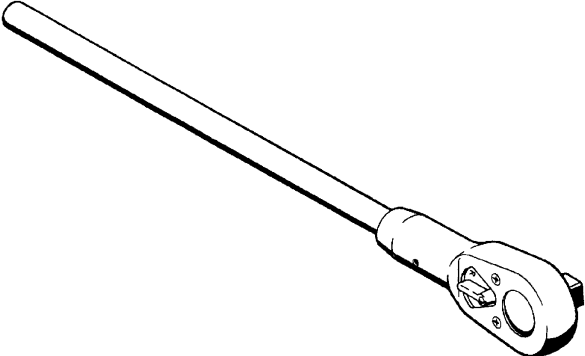

7 Special Tools

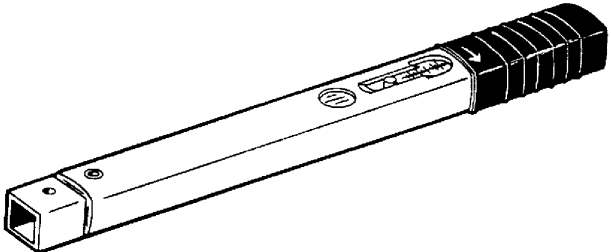
7.1 Special tools

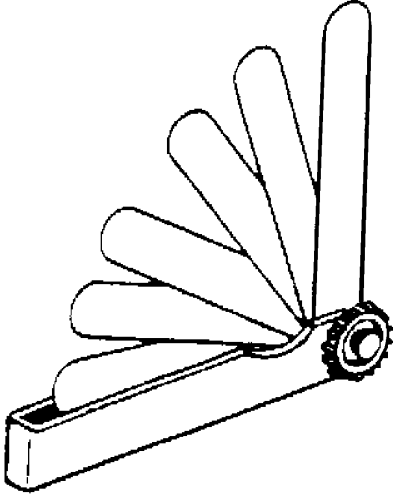
Part No.	Designation / Use	Qty.	
F6555766	Barring tool	1	
F30006212	Ratchet	1	

Part No.	Designation / Use	Qty.	
Y20097353	Rigid endoscope	1	 A rigid endoscope with a long, thin metal shaft and a black handle with a trigger mechanism.
F30027336	Torque wrench 6-50 Nm	1	 A torque wrench with a long, silver-colored shaft and a black handle with a textured grip. The handle has a scale and markings.

Part No.	Designation / Use	Qty.	
Y20010128	Feeler gauge	1	
F30047446	Torque wrench 60-320 Nm	1	

Part No.	Designation / Use	Qty.	
F30039526	Ring socket, 24 mm	1	
F30510423	Torque wrench 10-60 Nm	1	

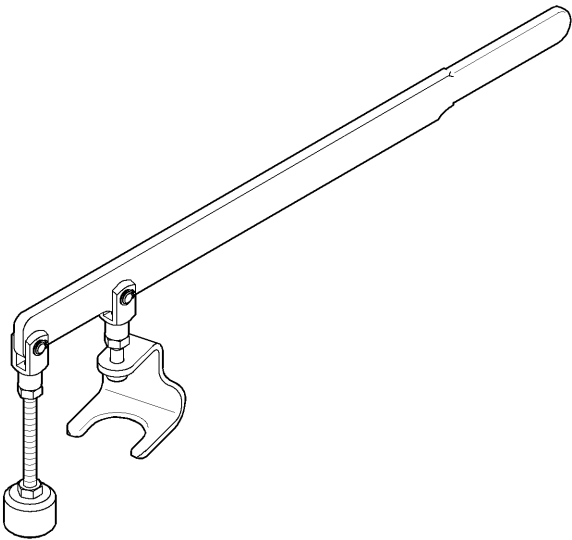
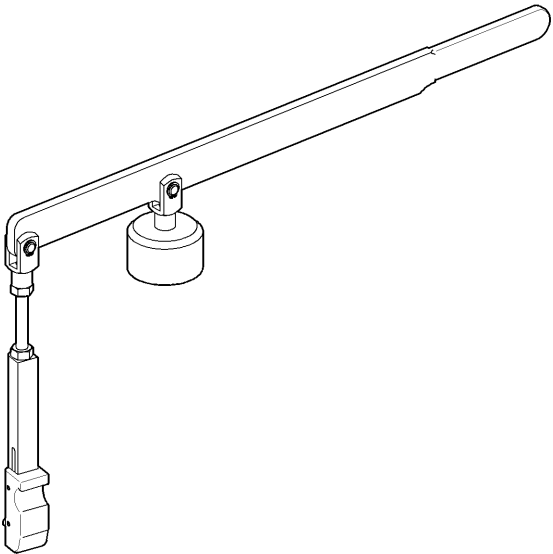
Part No.	Designation / Use	Qty.	
F6784183	Puller	1	
F6784167	Press-in tool	1	

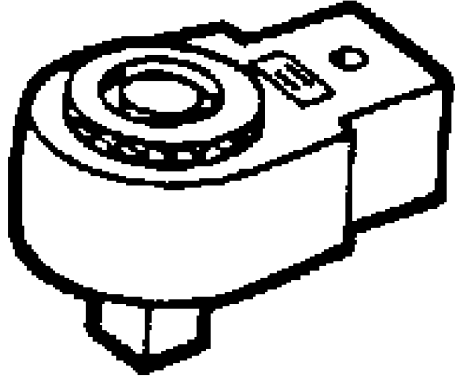
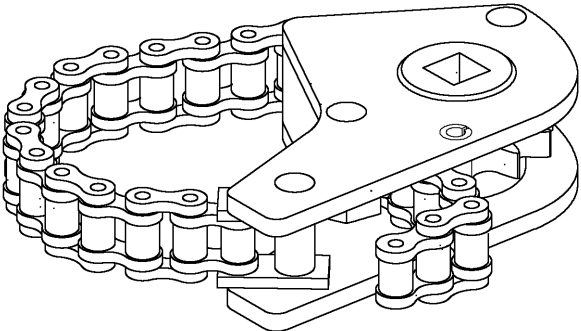
Part No.	Designation / Use	Qty.	
F30027341	Ratchet adapter	1	
F30379104	Filter wrench	1	

Part No.	Designation / Use	Qty.	
F30027337	Torque wrench	1	
5605892099/00	MTU test kit	1	 <p data-bbox="1289 1592 1453 1619">5605892099/00</p>

8 Annex

8.1 Manufacturer's documentation

See Manufacturer's documentation.

8.2 MTU contact person/service partner

You will find the MTU contact person/service partner for your region at www.mtu-online.com, worldwide, in the left-hand navigation margin.

8.3 Abbreviations

Abbreviation	Meaning	Explanation
A/D	Analog/Digital	Transformer: transforms sensor voltages into numeric values
AFRS	Air Filter Restriction Sensor	
ANSI	American National Standards Institute	
ATL	Abgasturbolader	Exhaust turbocharger (ETC)
ATS	Air Temperature Sensor	
BR	Baureihe	Engine Series
CAN	Controller Area Network	
CEL	Check Engine Light	1st function: Warning lamp (rectify fault as soon as possible) 2nd function: Read out fault codes
CKT	Circuit	
CLS	Coolant level sensor	Monitors coolant level
CPS	Coolant pressure sensor	Monitors coolant pressure
CTS	Coolant temperature sensor	Monitors coolant temperature
DDEC	Detroit Diesel Electronic Controls	Engine control system made by Detroit Diesel
DDL	Diagnostic Data Link	
DDR	Diagnostic Data Reader	
DIN	Deutsches Institut für Normung e. V.	German Standardization Organization, at the same time identifier of German standards ("Deutsche Industrie-Norm")
DL	Default Lost	Alarm: Default CAN bus failure
DT	Diagnostic Tool	
ECM	Electronic Control Module	Electronic control unit of the DDEC system
ECU	Engine Control Unit	Engine governor
EDM	Engine Data Module	
EEPROM	Electrically Erasable Programmable Read Only Memory	
EFPA	Electronic Foot Pedal Assembly	
EGR	Exhaust Gas Recirculation	
EMU	Engine Monitoring Unit	
EUI	Electronic Unit Injector	
FLS	Fluids and Lubricants Specification	MTU Publication No. A01061/..
FPS	Fuel Pressure Sensor	Monitors fuel pressure

Abbreviation	Meaning	Explanation
FRS	Fuel Differential Pressure Sensor	
FTS	Fuel Temperature Sensor	Monitors fuel temperature
GND	Ground	
HI	High	Alarm: Measured value exceeds 1st maximum limit
HIHI	High High	Alarm: Measured value exceeds 2nd maximum limit
HT	High Temperature	
IDM	Interface Data Module	
INJ	Injector	
ISO	International Organization for Standardization	
KGS	Kraftgegenseite	Engine free end in accordance with DIN ISO 1204
KS	Kraftseite	Engine driving end in accordance with DIN ISO 1204
LED	Light Emitting Diode	
LO	LOW	Alarm: Measured value lower than 1st minimum limit
LOLO	Low Low	Alarm: Measured value lower than 2nd minimum limit
LSG	Limiting Speed Governor	
N/A	Not Applicable	
OEM	Original Equipment Manufacturer	
OI	Optimized Idle	
OLS	Oil Level Sensor	Monitors oil level
OPS	Oil Pressure Sensor	Monitors oil pressure
OTS	Oil Temperature Sensor	Monitors oil temperature
OT	Oberer Totpunkt	Top dead center (TDC)
PAN	Panel	
PIM	Peripheral Interface Module	
PWM	Pulsewidth modulated	
P-xyz	Pressure-xyz	Pressure measuring point xyz
RL	Redundancy Lost	Alarm: Redundant CAN bus failure
SAE	Society of Automotive Engineers	U.S. standardization organization
SD	Sensor Defect	Alarm: Sensor failure

Abbreviation	Meaning	Explanation
SEL	Stop Engine Light	1st function: Warning lamp (stop engine and rectify fault) 2nd function: Read out fault codes
SID	System Identifier	
SPC	Spare Parts Catalog	
SRS	Synchronous Reference Sensor	TDC cylinder 1
SS	Safety System	Indicated alarm is initiated by the safety system
TBS	Turbocharger Boost Sensor	Monitors charge-air pressure
TC	Tools Catalog	
TCI	Turbo Compressor Inlet	
TCO	Turbo Compressor Outlet	
TD	Transmitter Deviation	Alarm: Sensor-comparison failure
TPS	Throttle Position Sensor	
TRS	Timing Reference Sensor	
T-xyz	Temperature-xyz	Temperature measuring point xyz
UT	Unterer Totpunkt	Bottom dead center (BDC)
VNT	Variable nozzle turbine	
VSG	Variable Speed Governor	
VSS	Vehicle Speed Sensor	

8.4 Index

12/16 V 4000 Gx3 engine data: Continuous operation, variable 3B, optimized exhaust emission (EPA stage 2)	46	Battery-charging generator drive – Drive belt tension adjustment	153
12V 4000 Gx3 engine data: Continuous operation, variable 3B, optimized exhaust emissions (TA-Luft)	51	Belt Drive	152
12V 4000 Gx3 engine data: Continuous operation, variable 3B, optimized fuel consumption	36	Drive belt – Condition check	152
12V 4000 Gx3 engine data: Standby operation 3D, optimized fuel consumption	21		
16V 4000 Gx3 engine data: Continuous operation, variable 3B, optimized fuel consumption	41	C	
16V 4000 Gx3 engine data: Standby operation 3D, optimized fuel consumption	26	Cabling, General for Engine / Gearbox / Plant	155
		Engine wiring – Check	155
A		Centrifugal oil filter – Cleaning and filter-sleeve replacement	137
Abbreviations	169	Charge-air coolant – Draining	149
Accessories for Engine Governor (Electronic) / Control System	156	Charge-air coolant – Filling	147
ECU – Checking plug-in connections	157	Charge-air coolant change	146
ECU and connectors – Cleaning	156	Charge-air coolant level check	150
After stopping the engine – engine remains ready for operation	62	Charge-air coolant pump – Relief bore check	151
After stopping the engine – putting the engine out of service	63	Charge-air Cooling, General, Left Side	124
Air Filter	125	Intercooler – Checking condensate drains for coolant discharge and obstructions	124
Air filter – Check	126	Cooling Circuit, General, HT Circuit	139
Air filter removal and installation	127	Engine coolant – Change	139
Air filter replacement	125	Engine coolant – Draining	142
Rubber sleeves between air intake elbow and turbocharger – Replacement	128	Engine coolant – Filling	140
Air filter – Check	126	Engine coolant – Sample extraction and analysis	145
Air filter removal and installation	127	Engine coolant level – Check	143
Air filter replacement	125	Engine coolant pump – Relief bore check	144
Air Intake	129	Crankcase Breather	102
Service indicator – Signal ring position check	129	Crankcase breather – Oil separator replacement, diaphragm check and replacement	102
Air starter – manual operation	130	Crankcase breather – Oil separator replacement, diaphragm check and replacement	102
Auxiliary materials, fire prevention and environmental protection	11	Cylinder head cover – Remove and install	108
		Cylinder Liner	98
B		Cylinder liner – Endoscopic examination	98
Battery-charging Generator	153	Instructions and comments on endoscopic and visual examination of cylinder liners	100
Battery-charging generator drive – Drive belt replacement	154	Cylinder liner – Endoscopic examination	98
Battery-charging generator drive – Drive belt tension adjustment	153		
Battery-charging generator drive – Drive belt replacement	154	D	
		Drive belt – Condition check	152
		E	
		ECU – Checking plug-in connections	157
		ECU and connectors – Cleaning	156

Emergency start (override mode)	58	Fuel prefilter – flushing	120
Emergency stop	61	Fuel prefilter cleaning	116
Engine	95	Fuel filter – Replacement	115
Engine – Barring manually	95	Fuel prefilter – differential pressure check and adjustment of gauge	117
Engine – Barring with starting system	96	Fuel prefilter – draining	118
Engine test run	97	Fuel prefilter – filter element replacement	122
Engine – Barring manually	95	Fuel prefilter – flushing	120
Engine – Barring with starting system	96	Fuel prefilter cleaning	116
Engine – Main dimensions	18	Fuel System	114
Engine coolant – Change	139	Fuel system – Venting	114
Engine coolant – Draining	142	Fuel system – Venting	114
Engine coolant – Filling	140		
Engine coolant – Sample extraction and analysis	145	G	
Engine coolant level – Check	143	General conditions	05
Engine coolant pump – Relief bore check	144		
Engine data 12/16V 4000 Gx3: Standby operation 3D, optimized exhaust emissions (EPA stage 2)	31	I	
Engine governor ADEC (ECU 7) for Series 4000 genset engines - Fault messages	74	Index	173
Engine layout	15	Injector	109
Engine Layout	15	Injector – Removal and Installation	110
Engine layout	15	Injector – Replacement	109
Engine oil – Change	132	Injector – Removal and Installation	110
Engine oil – Level check	134	Injector – Replacement	109
Engine oil – Sample extraction and analysis	135	Instructions and comments on endoscopic and visual examination of cylinder liners	100
Engine oil filter – Replacement	136	Intercooler – Checking condensate drains for coolant discharge and obstructions	124
Engine side and cylinder designations	17		
Engine Side and Cylinder Designations	17	L	
Engine side and cylinder designations	17	LT Circuit	146
Engine test run	97	Charge-air coolant – Draining	149
Engine wiring – Check	155	Charge-air coolant – Filling	147
		Charge-air coolant change	146
F		Charge-air coolant level check	150
Final compression pressure	20	Charge-air coolant pump – Relief bore check	151
Final Compression Pressure	20	Lube-oil System, Lube-oil Circuit	132
Final compression pressure	20	Engine oil – Change	132
Firing order	19	Engine oil – Level check	134
Firing Order	19	Engine oil – Sample extraction and analysis	135
Firing order	19		
Fuel Filter	115	M	
Fuel filter – Replacement	115	Main Engine Dimensions	18
Fuel prefilter – differential pressure check and adjustment of gauge	117	Engine – Main dimensions	18
Fuel prefilter – draining	118	Maintenance schedule matrix	66
Fuel prefilter – filter element replacement	122	Maintenance tasks	68
		Manufacturer’s documentation	167
		MTU contact person/service partner	168

O		T	
Oil Filtration/Cooling	136	Technical Data	21
Centrifugal oil filter – Cleaning and filter-sleeve replacement	137	12/16 V 4000 Gx3 engine data: Continuous operation, variable 3B, optimized exhaust emission (EPA stage 2)	46
Engine oil filter – Replacement	136	12V 4000 Gx3 engine data: Continuous operation, variable 3B, optimized exhaust emissions (TA-Luft)	51
Operational checks	59	12V 4000 Gx3 engine data: Continuous operation, variable 3B, optimized fuel consumption	36
		12V 4000 Gx3 engine data: Standby operation 3D, optimized fuel consumption	21
		16V 4000 Gx3 engine data: Continuous operation, variable 3B, optimized fuel consumption	41
		16V 4000 Gx3 engine data: Standby operation 3D, optimized fuel consumption	26
		Engine data 12/16V 4000 Gx3: Standby operation 3D, optimized exhaust emissions (EPA stage 2)	31
		Transport	07
		Troubleshooting	71
		V	
		Valve clearance – Check and adjustment	105
		Valve Drive	104
		Cylinder head cover – Remove and install	108
		Valve clearance – Check and adjustment	105
		Valve gear – Lubrication	104
		Valve gear – Lubrication	104
P			
Personnel and organizational require- ments	06		
Preface	65		
Putting the engine into operation after extended out-of-service-periods (>3 months)	55		
Putting the engine into operation after scheduled out-of-service-period	56		
R			
Rubber sleeves between air intake elbow and turbocharger – Replacement	128		
S			
Safety requirements when working on the engine	08		
Service indicator – Signal ring position check	129		
Special tools	159		
Standards for warning notices in the publication	13		
Starting Equipment	130		
Air starter – manual operation	130		
Starter – Condition check	131		
Starter – Condition check	131		
Starting the engine in manual mode	57		
Stopping the engine in manual mode	60		

