

No.: 05 TS – 55rev2
August 7, 2006

TO: DDC Distributors, FLLC Dealers

FROM: Technical Service

SUBJECT: **2004 MBE 4000 EGR Piston and Oil Spray Nozzle**

ISSUE

A new piston and oil spray nozzle were developed and implemented for the 2004 MBE 4000 EGR. This piston and spray nozzle combination is used on engines effective with engine s/n: 0460813072. Oil spray nozzle-to-piston alignment is critical. If alignment is not correct, engine damage may occur. Also, the different styles of pistons must never be mixed in the same engine.

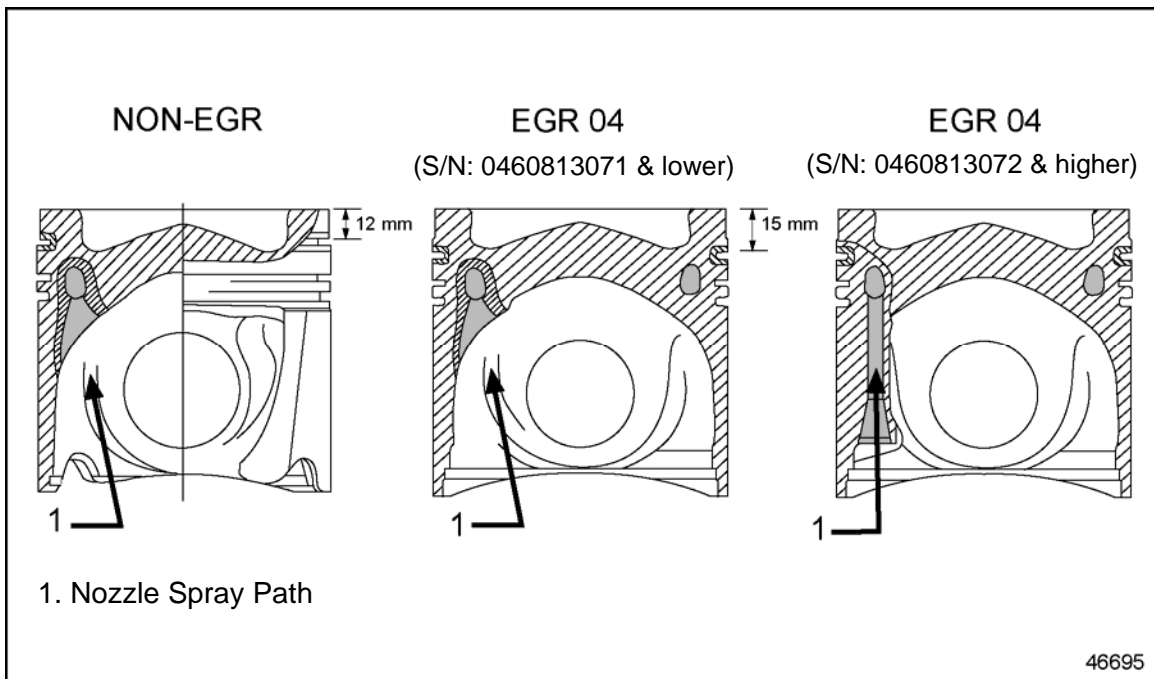

Figure 1 MBE 4000 Piston Cooling Designs

REQUIRED ACTION

Check each piston for spray nozzle alignment. Proper alignment should result in a nozzle that **NEVER** comes into contact with **ANY** part of the piston (skirt, underside of the dome, etc.).

When servicing spray nozzles, pistons, or any component within the engine where accidental damage to the spray nozzle can occur, slowly rotate the crankshaft using either special tool J-46392 (new tool number) or J-46167 (old tool number). If resistance is felt during crankshaft rotation, inspect spray nozzles for interference (see the repair procedure below). Be especially careful of contact with the underside of the dome, since this contact may be difficult to feel while rotating the crankshaft. If needed, use two people for this process; one person can rotate the crankshaft while the other one inspects the pistons and nozzles. Remember that the nozzle should **NEVER** contact **ANY** portion of the piston.

NEVER mix different styles of pistons in the same engine. The weights of the pistons are different, and if mixed in an engine can cause an imbalance.

- When installing nozzles:
 1. Align guide pin on nozzle to the hole in the crankcase.
 2. Hand tighten mounting bolt.
 3. Torque mounting bolt to 40 Nm (30 lb-ft). Reference the *MBE 4000 Service Manual* (6SE412).
- Checking nozzle alignment:
 1. Install engine barring tool J-46392 or J-46167.
 2. Rotate crankshaft while inspecting nozzle.
 3. As piston reaches BDC check the alignment of the nozzle to the piston. The nozzle tip will enter the oil galley in the piston. (See Figure 2).
 4. Continue checking remaining cylinders.

REQUIRED MATERIAL

Listed below are the current service part numbers involved in each generation of piston design.

<u>Engine Type</u>	<u>Piston P/N:</u>	<u>Piston kit (includes liner) P/N:</u>	<u>Oil Spray Nozzle P/N:</u>
Non-EGR	4600300517	4600300937	4601800043
EGR s/n: 0460813071 and lower)	4600300817	4600301337	4601800343
EGR s/n: 0460813072 and higher)	4600301017	4600301237	4601800443

REPAIR PROCEDURE

If the spray nozzle contacts the piston, **DO NOT** reuse or bend. Replace with a new nozzle of the correct type (see Figures 3 and 4). If there is any question about the quality of the spray nozzle, replace the nozzle.

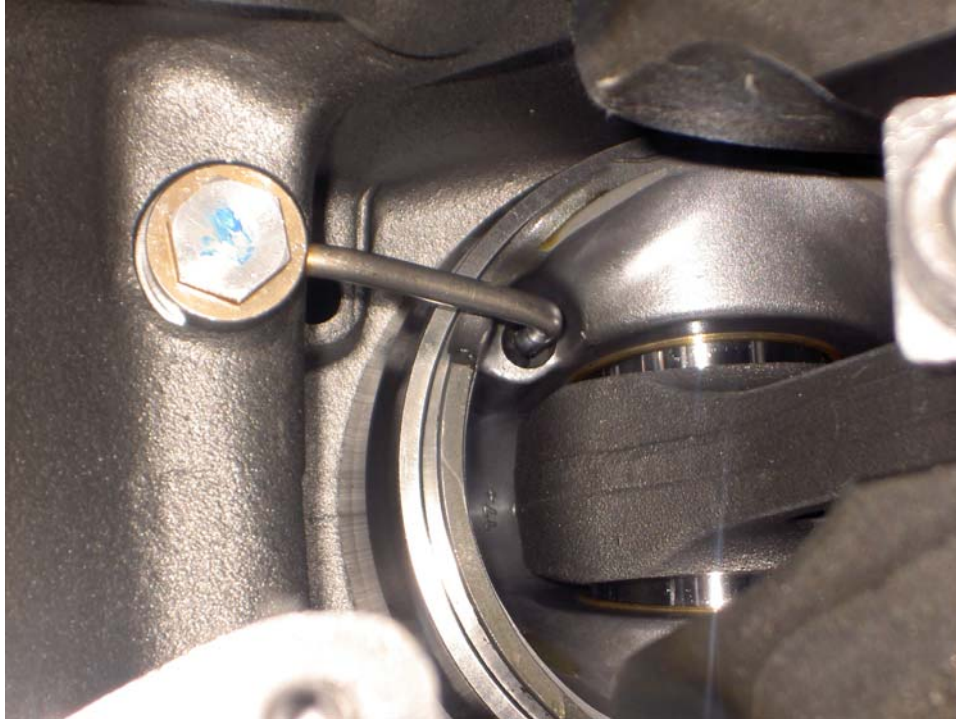
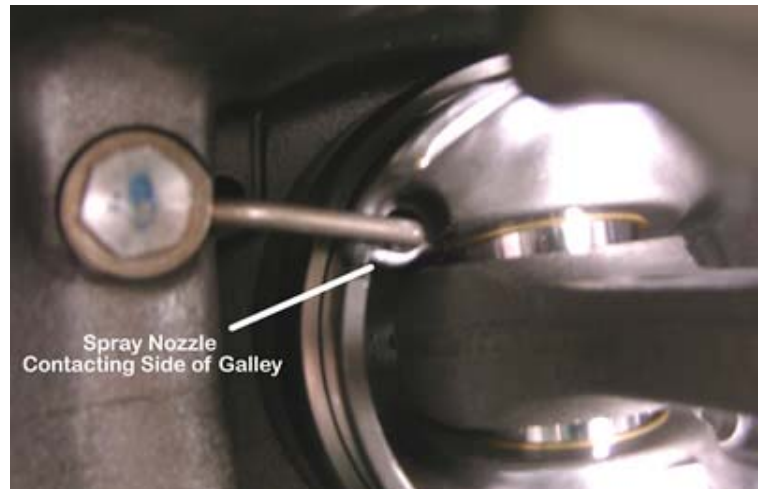
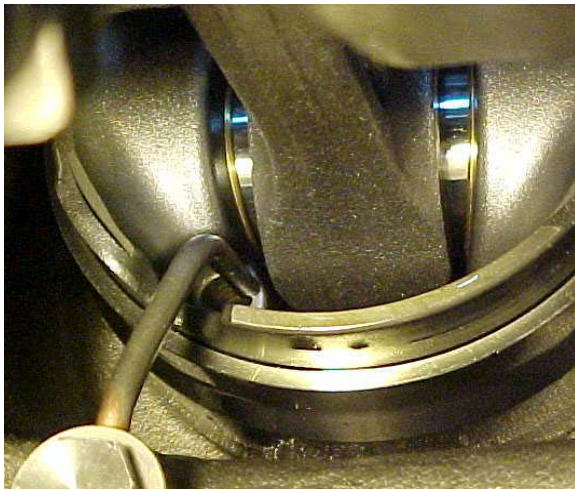

Figure 2 Correct Alignment



Figures 3 and 4 - Incorrect Alignment

ADDITIONAL INFORMATION

Please reference 05 TL-04Rev Tool Letter for additional information.

CONTACT INFORMATION

Please contact the DDC Customer Support Center at 313-592-5800 if you have any questions.