

DETROIT DIESEL



MBE 4000 Service Information

NUMBER: 08 MBE 4000-1 REV **S.M. REF.:** 1.3 **ENGINE:** EPA04 MBE 4000 **DATE:** February 2008

SUBJECT: CYLINDER BLOCK LINER SERVICE PROCEDURE

PUBLICATION: DDC-SVC-MAN-0023 (6SE412)

Amended tool number J-46180.

New procedure describes the steps needed to service the engine with the installation of the new design liner with the D-ring seal.

1.3.1 REMOVAL OF CYLINDER LINER

Removal steps are as follows:

1. Remove the piston. Refer to section "Removal of Piston".

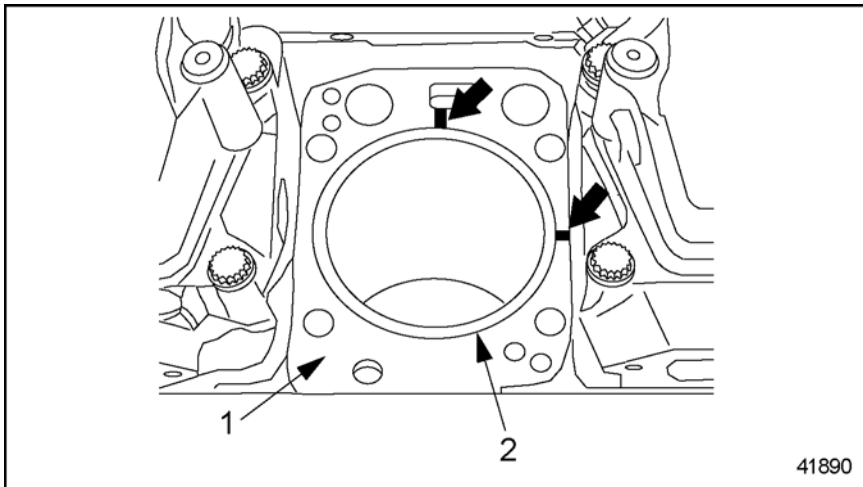

1. Cylinder Block

2. Cylinder Liner

Figure 1 Mark the Cylinder Liner

2. Using a paint pen, mark the position of the cylinder liner in the cylinder block. Mark both the cylinder liner and the block. Then make another set of marks 90 degrees from the first set, in a clockwise direction. See Figure 1.

NOTE:

If the same cylinder liner is used again, it must be installed at an offset of 90 degrees from its last position. This reference will not be needed if the cylinder liner is being replaced.

NOTICE:
To prevent cylinder liner damage, never use a hammer or other unsuitable device to remove the cylinder liner.

3. Remove the cylinder liner, using the cylinder liner removal tool (J-45876). See Figure 2.
 - [a] Clean and wipe out the inside of the cylinder liner of any oil or coolant.
 - [b] Install the cylinder liner removal tool in the cylinder liner to be removed with bridge resting on deck of cylinder block and lip of tool resting on the top of the cylinder liner.
 - [c] Tighten the lower nut to expand the tool in the cylinder liner.

- [d] Tighten the upper nut on the tool until the cylinder liner is pulled from the cylinder block. Remove the cylinder liner and tool.
- [e] Remove the tool from the cylinder liner.

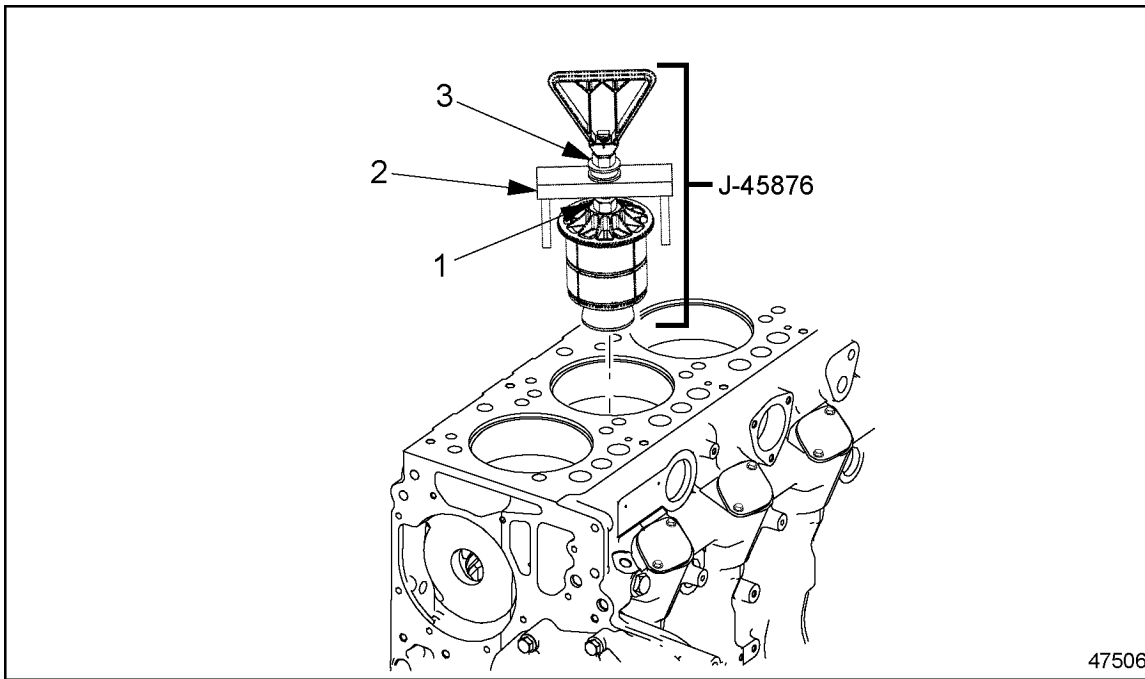

1. Lower Nut

3. Upper Nut

2. Resting Bridge

Figure 2 Cylinder Liner Removal Tool J-45876

- 4. Remove the shim from the block counterbore.

5. Remove and discard the two O-rings from the block.

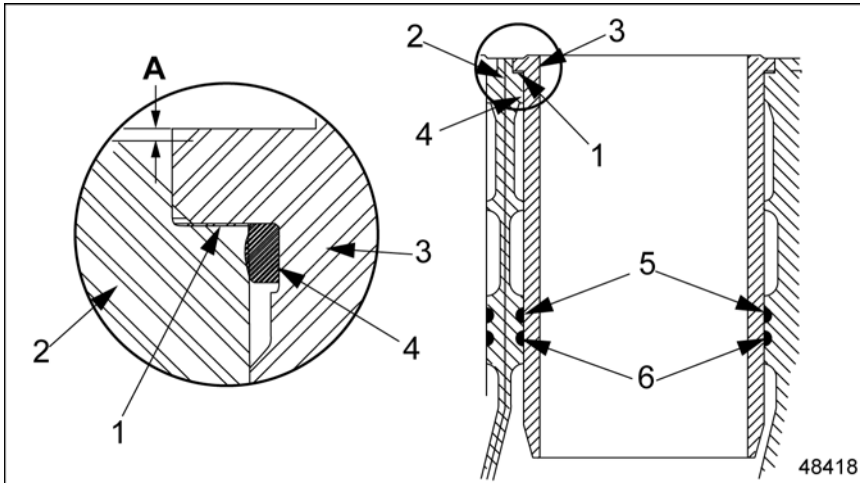

- 1. Collar Seat Insert (shim)
- 2. Block
- 3. Cylinder Liner
- 4. Liner D-Ring

- 5. Upper O-ring
- 6. Lower O-ring
- A. Specified in Measuring Cylinder Liner Protrusion Table

Figure 3 Cylinder Liner O-rings

- 6. Clean the cylinder block sealing areas and inspect for corrosion.
- 7. Check the condition of the cylinder liner collar seat. Ensure that the depth of the collar seat is within the specifications listed in Table 1.

Description	Dimensions: mm (in.)
Cylinder Liner Protrusion, From Block, see Figure 3, Ref. A.	0.230–0.330 (0.0090–0.0130)
Height of the Cylinder Liner Collar, see Figure 3	10.10–10.12 (0.3976–0.3984)
Depth of the Collar Seat, see Figure 3	9.950–10.010 (0.3917–0.3941)
Thickness of the Seat Insert	0.14–0.16 (0.0055–0.0063)

Table 1 Cylinder Liner Installation Tolerances

8. Check the condition of the liner collar seat. Make sure that the depth of the collar seat is within the specifications given, listed in Table 2.

Description	Dimensions: mm (in.)
Admissible Out-of-Round of the Cylinder Liner, where it contacts the O-rings	Max.: 0.02 (0.0008)
Admissible Deformation of the Cylinder Liner Collar, at the Contact Surface with the Seat Insert	Max.: 0.02 (0.0008)
Admissible Deformation of the Cylinder Liner Collar Seat, at the Contact Surface with the Seat Insert	Max.: 0.03 (0.0012)

Table 2 Cylinder Liner Inspection Tolerances

1.3.1.2 MEASUREMENT OF CYLINDER LINER PROTRUSION

Measurement steps are as follows:

1. Clean the contact surfaces of the cylinder block, the cylinder liner, and the measuring plate.

NOTE:

Correct cylinder liner protrusion is necessary to obtain a perfect seal when the head gasket is compressed by the cylinder head.

2. Install the liner and shim into the block without the seals.
3. Install the measuring plate (J-46180) on the cylinder block and cylinder liner. Fasten the measuring plate to the block by inserting the cylinder head bolts into the spacers and then threading them into the holes in the cylinder block. See Figure 4.

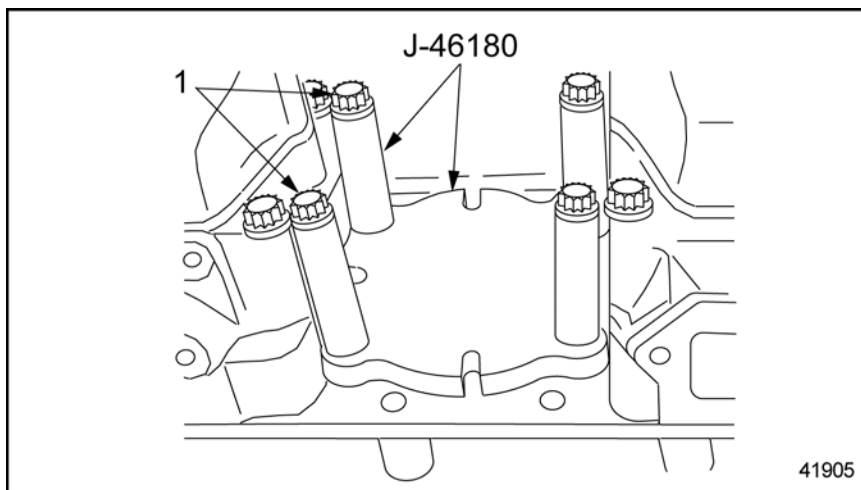

1. Cylinder Head Bolts

Figure 4 Measuring Plate Installation

4. Tighten the cylinder head bolts 50 N·m (37 lb·ft).

5. Install the dial gauge so that the feeler on the dial gauge extends into the slot in the measuring plate. The feeler must touch the contact surface of the cylinder block with some preload. Support the dial gauge. See Figure 5.

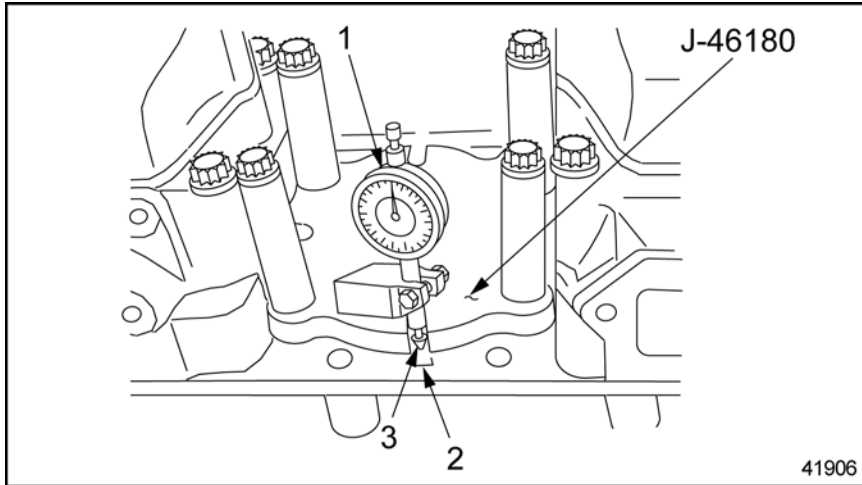

1. Dial Gauge

3. Feeler

2. Slot (4 qty.)

Figure 5 Dial Gauge Installation

6. Measure the cylinder liner protrusion from the block in four places, once at each slot in the measuring plate. See Figure 6. The acceptance/rejection criteria is listed in Table 3.

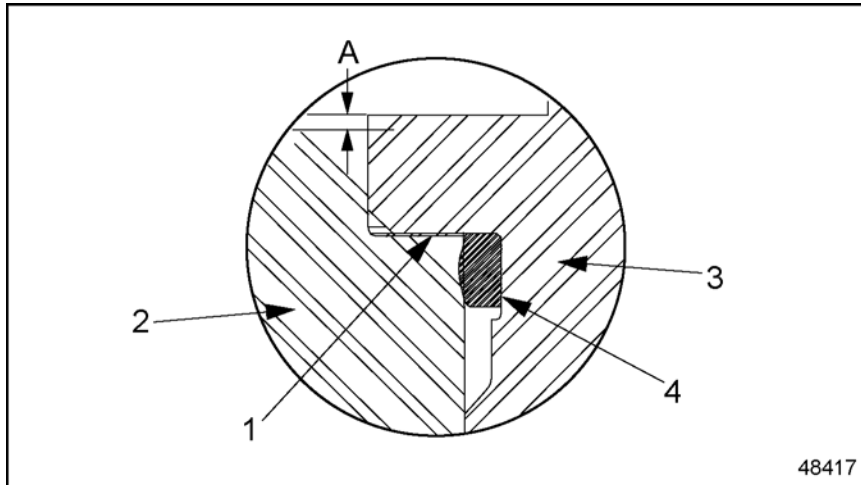

- 1. Collar Seat Insert (shim)
- 2. Cylinder Block
- 3. Cylinder Liner

- 4. Liner Seat D-Ring
- A. Specified in Measuring Cylinder Liner Protrusion Table

Figure 6 Measuring Protrusion

Description	Value: mm (in.)
Cylinder Liner Protrusion From Block	0.230–0.330 (0.0090–0.0130)
Difference Between the Four Measuring Points	Max.: 0.02 (0.0007)

Table 3 Specifications for Measuring Cylinder Liner Protrusion

- [a] Set the scale on the dial gauge to zero.
- [b] Move the dial gauge until the feeler touches the cylinder liner collar. Record the reading on the dial gauge.
- [c] Move the dial gauge and support to the next slot, and repeat the measurement process, until four measurements have been made, one at each slot. Record each measurement.
- [d] Check each measurement. If any one measurement records protrusion of less than 0.230 mm (0.0090 in.), or more than 0.330 mm (0.0130 in.), remove the cylinder liner. Refer to section 1.3.1.2 Measurement of Cylinder Liner Protrusion for inspection procedure.

NOTE:

There are three different cylinder liner shim thicknesses that are available, 0.15mm, 0.30mm and 0.50mm.

[e] Compare the four measurements. If any measurement differs from any one of the others by more than 0.02 mm (0.0008 in.), replace the cylinder liner and repeat steps “a” through “e”. If the cylinder liner measurements are within specification continue to step 7.

7. Remove the bolts, spacers and measuring plate, as installed.

1.3.2 CYLINDER BLOCK PREPARATION

This procedure is used with the (PT-2250-B) counterbore tool and (J-41065).

1. Remove the cylinder heads, pistons, liners, and other hardware.
2. Protect the crankshaft, oil, and coolant passages from machining debris by covering with a shop towel or a suitable clean cover. Clean the top surface of the block to remove any debris from the machining area.
3. Remove the cylinder block dowel pins using (Snap-On CG503 or equivalent).
4. Remove the coolant pump. Refer to section "Removal of Coolant Pump".
5. Remove the rear lifting bracket.
6. Protect internal engine parts from cutting debris using an oiled sponge filler in the cylinder block.
7. The cutting edge of the cutting bit should be retracted to protect the cutting tool (PT-2250-B). Cap screws of the cutter should be loose at this time.

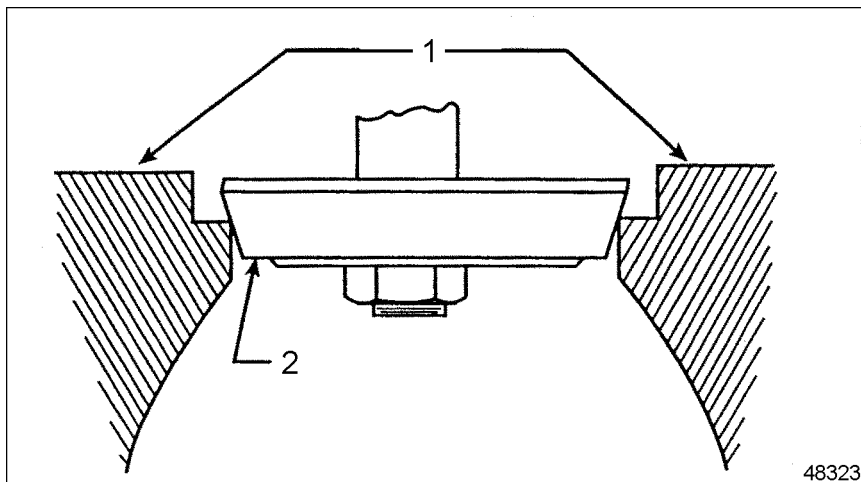

1. Cylinder Block

2. Cutter Plate

Figure 7 Cross Section

8. Center the tool on the top of the block using the Counter Bore Cutter tool (J-41065).

9. Raise the depth stop adjustment collars and lower the tapered cutter plate into the bore. Rotate the tool and allow it to center itself in the bore.

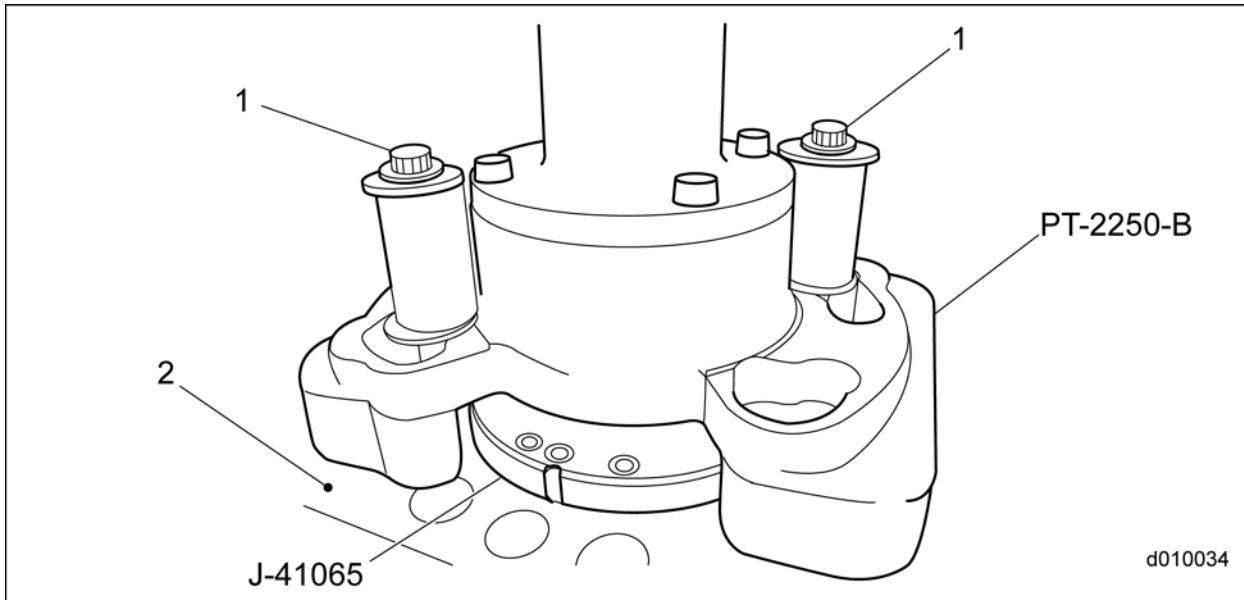

1. Cylinder Head Bolt

2. Cylinder Block

Figure 8 Cutting Tool

10. Install two opposing cylinder head bolts with the washers and spacers through the base plate of the tool. Tighten securely to 41 N·m (30 lb·ft.).
11. Raise the tapered cutter head from the block and install the depth set spacer provided. While there is no load, extend the cutting tool outward (using a clockwise rotation of the cutting screw) until it just touches a 0.15mm feeler gauge or shim placed next to the vertical wall of the counterbore. Tighten the Allen head hold-down screws.
12. Lower the cutting plate and cutter tool into the counterbore until it just touches the lower surface of the counterbore. Rotate the lock collars downward until they touch the bronze bushing of the tool.
13. Set the depth of cut by adjusting the top collar upwards to allow the liner shim to be inserted between the two collars. Tighten the thumb screw of the top collar. Remove the shim.

14. Lubricate the tool bushing. Back off the lower collar by two graduations 0.0254 mm (0.001 in. each). Rotate the T-handle clockwise with a moderate, constant pressure. Stop at random positions to prevent creating a ridge in the counterbore. Continue backing off the adjustment in 0.0508 mm (0.002 in.) increments for the balance of the cutting operation until the collars come together.
15. Raise the handle and insert the spacer block under the lower collar. Remove the hold-down bolts and spacers to remove the tool from the block.
16. Retract the cutter bit into the cutter plate to protect during storage.

NOTICE:
After machining the cylinder block, inspect for the presence of a chamfer on the edge of the balcony. Use a hand stone to break the sharp edge if needed.

1.3.3 INSTALLATION OF CYLINDER LINER

Installation steps are as follows:

1. Perform the Measurement of Cylinder Liner Protrusion procedure. Refer to section "Measurement of Cylinder Liner Protrusion".
2. Install new O-rings, clean and dry, in the cylinder block.

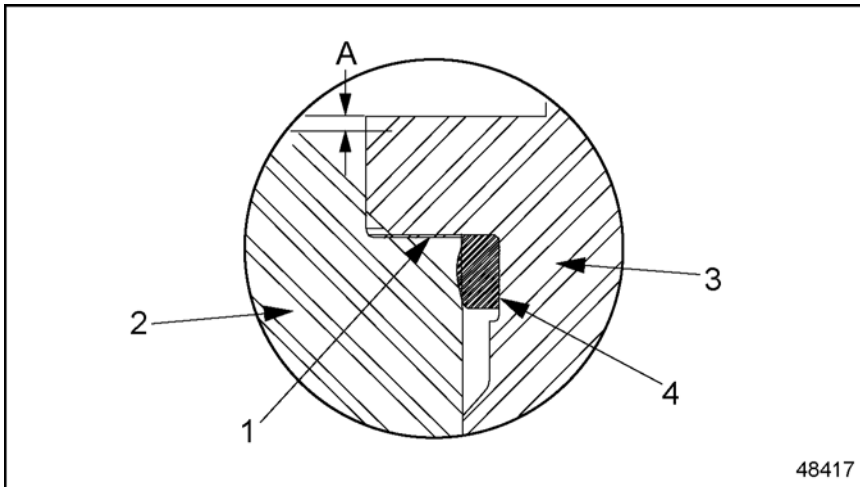

1. Collar Seat Insert (shim)

2. Cylinder Block

3. Cylinder Liner

4. Liner Seat D-Ring

A. Specified in Measuring Cylinder Liner Protrusion Table

Figure 9 Cylinder Liner Seat

3. Install Liner Seat D-Ring to Cylinder Liner. Be sure the D-ring is installed with the flat surface of the of the ring against the liner. Be careful not to over-stretch the ring as it is installed over the liner flange.

NOTE:

The cylinder liner collar and collar seat must remain completely free of oil.

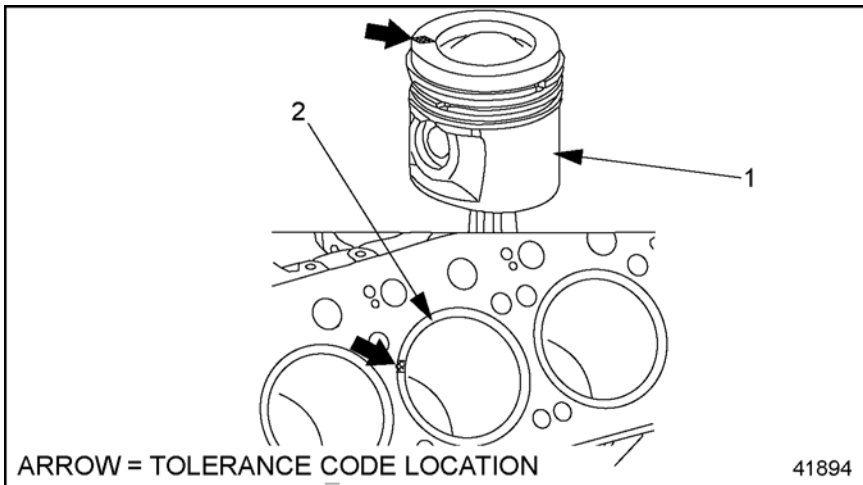

1. Piston

2. Cylinder Liner

Figure 10 Tolerance Codes

4. Install a new seat insert, clean and dry, into the block counterbore.
5. Apply a light coating of engine oil to the lower part of the cylinder liner, from where it contacts the O-rings up to the bevelled area.
6. When installing a new cylinder liner, make sure that the diameter tolerance code corresponds to the one marked on the piston. For tolerance codes location refer to the edge of the cylinder liner.
 - [a] Cylinder liners with tolerance code A require a piston of code BA.
 - [b] Cylinder liners with tolerance code B require a piston of either code BA or BC.
 - [c] Cylinder liners with tolerance code C require a piston of code BC.
7. Install the cylinder liner, using the cylinder liner installation tool (J-46168).

NOTICE:

Do not overtighten the installation tool. This may deform the cylinder liner and make the installation tool more difficult to remove.

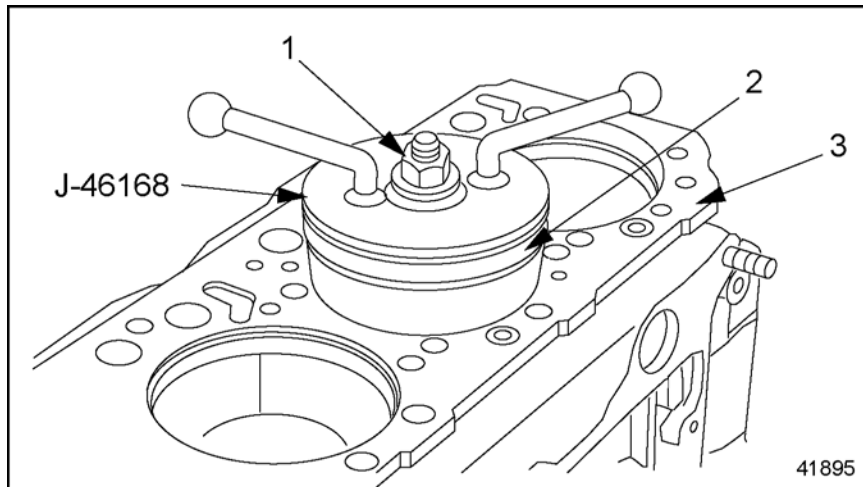

1. Installation Nut

3. Cylinder Block

2. Cylinder Liner

Figure 11 Cylinder Liner

- [a] Tighten the installation tool just enough to hold the installation tool inside the cylinder liner without turning.

NOTICE:

To prevent damage to the O-rings, the cylinder liner must be rotated during installation.

NOTE:

If installing the old cylinder liner, offset the reference marks 90 degrees from the previous ones.

- [b] Insert the cylinder liner into the cylinder block until it contacts the O-rings. Continue to insert the cylinder liner past the O-rings, being careful to keep turning the installation tool until the cylinder liner is properly seated.
- [c] Remove the installation tool from the cylinder liner.

8. Measure the cylinder liner protrusion from the block. The specifications are listed in Table 4.

Description	Dimensions: mm (in.)
Cylinder Liner Protrusion, From Block, see Figure , Ref. A.	0.230–0.330 (0.0090–0.0130)
Height of the Cylinder Liner Collar, see Figure	10.10–10.12 (0.3976–0.3984)
Depth of the Collar Seat, see Figure	9.950–10.010 (0.3917–0.3941)
Thickness of the Seat Insert	0.14–0.16 (0.0055–0.0063)

Table 4 Cylinder Liner Installation Tolerances

9. Measure the inside diameter of the cylinder liner and check for out-of-round.

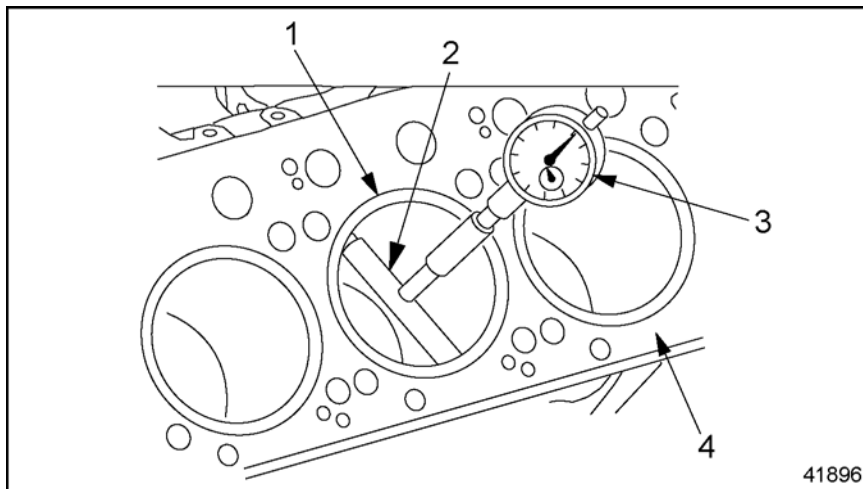

- 1. Cylinder Liner
- 2. Quick Calipers
- 3. Dial Gauge
- 4. Cylinder Block

Figure 12 Measuring the Cylinder Liner Inside Diameter

- [a] Measure at three different locations 60 degrees apart in the area of the two O-rings.
 - [b] Compare the three measurements. If they differ by more than the maximum admissible out-of-round listed in Table , remove the cylinder liner and inspect the two O-rings and their seating area in the cylinder block.
 - [c] If the O-rings are damaged, replace them.
 - [d] Check the out-of-round again until it meets specifications.
10. Install the piston. Refer to section "Installation of Piston".

ADDITIONAL SERVICE INFORMATION

Additional service information is available in the Detroit Diesel *EPA04 MBE 4000 Service Manual* DDC-SVC-MAN-0023 (6SE412). The next revision to this manual will include the revised information.

DETROIT DIESEL
CORPORATION



13400 Outer Drive, West / Detroit, Michigan 48239-4001
Telephone: 313-592-5000
www.detroitdiesel.com