

DETROIT DIESEL



Installation Instructions

18SP616 – MBE4000 Extended Fill / Dipstick 40L Rear Sump Kit - Car Hauler (P/N: 23535992)

KIT DESCRIPTION

This kit (P/N: 23535992) permits the installation of an extended oil fill / dipstick assembly on a 40L rear sump MBE4000 EGR engine (Car hauler).

KIT CONTENTS

See Table 1 for the extended fill / dipstick kit contents:

Part No.	Qty.	Description
A 460 010 09 64	1	Oil Fill Tube
A 344 018 03 68	1	Oil Fill Cap
A 352 018 67 40	1	Strap, Oil Cap
N 007 337 00 40 09	1	Rivet
A 000 995 12 77	2	Clamp
A 460 010 06 40	1	Bracket, Oil Fill/Dipstick
N 910 105 01 00 06	3	Bolt, M10 x 20
A 460 010 08 40	1	Bracket, Support / Stiffening
A 460 010 10 66	1	Guide Tube, RR Sump 40L (Car Hauler)
A 460 010 33 72	1	Dipstick, RR Sump 40L (Car Hauler)
A 470 997 00 71	1	Fitting, Oil Pan
N 007 603 01 81 01	1	Seal Ring
N 910 105 00 60 04	5	Bolt, M6 x 16
23536043	3	P-Clip
23535543	2	Double Cable Strap
052 212 00 01	1	FLC Radiator Hose
18SP616	1	Installation Instructions

Table 1 Components of MBE4000 Extended Fill / Dipstick Kit (P/N: 23535992)

INSTALLATION PROCEDURE

Perform the following steps for removal of current components and installation of new kit components:

WARNING:

HOT COOLANT

To avoid scalding from the expulsion of hot coolant, never remove the cooling system pressure cap while the engine is at operating temperature. Wear adequate protective clothing (face shield, rubber gloves, apron, and boots). Remove the cap slowly to relieve pressure.

1. Drain the coolant to a level below upper radiator hose. Remove upper radiator hose. Remove standard oil fill, dipstick, guide tube, fitting, and fill / dipstick bracket.
2. Install the FLC radiator hose (P/N: 052 212 00 01). Top off cooling system.
3. Install fill / dipstick bracket (P/N: 460 010 06 40) to top of alternator bracket using three M10 x 20 bolts (P/N: N 910 105 01 00 06). Do not tighten bolts. See Figure 1.
4. Install support / stiffening bracket (P/N: 460 010 08 40) to dipstick bracket using one M6 x 16 bolt (P/N: N 910 105 00 60 04). See Figure 2. Torque the three M10 x 20 bolts to 46 N·m (34 lb·ft). See Figure 1. Torque the one M6 x 16 bolt to 9 N·m (6.6 lb·ft). See Figure 2.

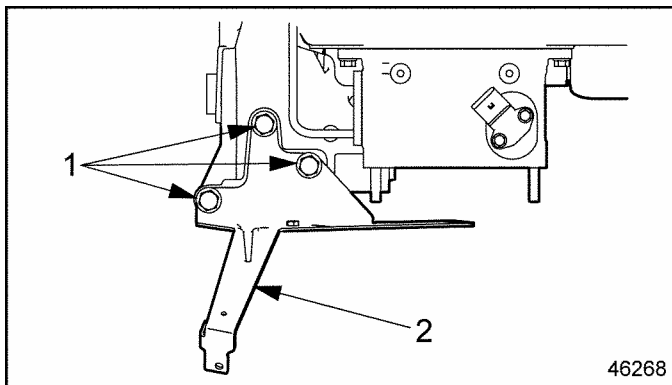

1. Fill / Dipstick Bracket Bolts, M10 x 20 (3) 2. Fill / Dipstick Bracket

Figure 1 Installing Fill / Dipstick Bracket to Alternator Bracket

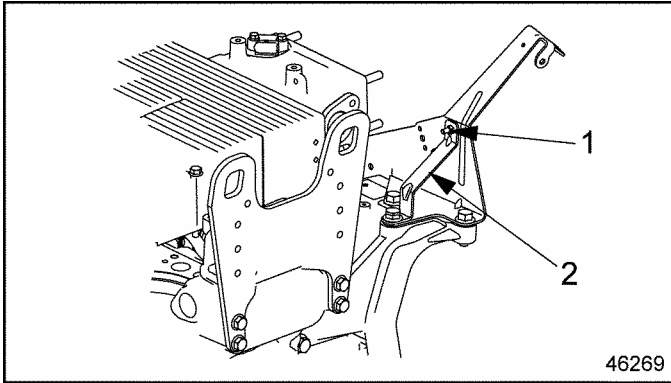

1. Support/Stiffening Bracket Bolt, M6 x 16 2. Support/Stiffening Bracket

Figure 2 Installing Support / Stiffening Bracket

5. Install dipstick connector fitting (P/N: 470 997 00 71) to oil pan, using seal ring (P/N: N 007 603 01 81 01). Torque fitting to 50 N·m (37 lb·ft). See Figure 3.

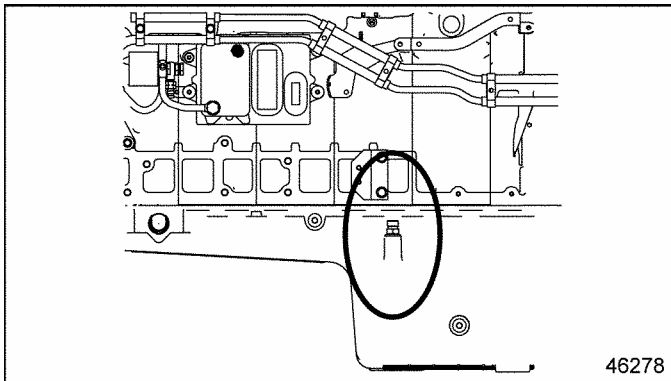
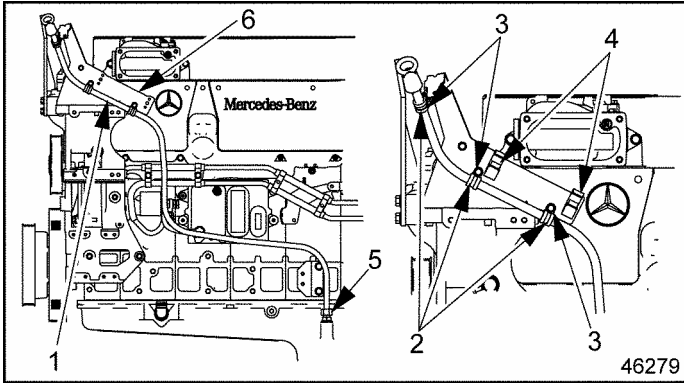

Figure 3 Installing Dipstick Connector Fitting to Oil Pan

6. Install dipstick guide tube (P/N: 460 010 10 66) to oil pan fitting with M22 nut, which is attached to the dipstick guide tube. Also attach dipstick guide tube to block using three P-Clips (P/N: 23536043) and three M6 x 16 bolts (P/N: N 910 105 00 60 04). Tighten M22 nut to 70 N·m (52 lb·ft). Torque M6 x 16 bolts to 9 N·m (6.6 lb·ft). See Figure 4.



- | | |
|-----------------------------------|--------------------------------|
| 1. Dipstick Guide Tube | 4. Oil Fill Tube Clamps |
| 2. P-Clips | 5. Nut, M22 |
| 3. P-Clip Bolts, M6 x 16 (3 qty.) | 6. Oil Fill / Dipstick Bracket |

Figure 4 Installing Dipstick Guide Tube

7. Insert dipstick (P/N: 460 010 33 72) in the dipstick guide tube.
8. Snap two oil fill tube clamps (P/N: 000 995 12 77) into holes located on oil fill / dipstick bracket. See Figure 4.
9. Attach oil fill tube (P/N: 460 010 09 64) to oil pan and clamp to bracket. Orient neck to front. See Figure 5.

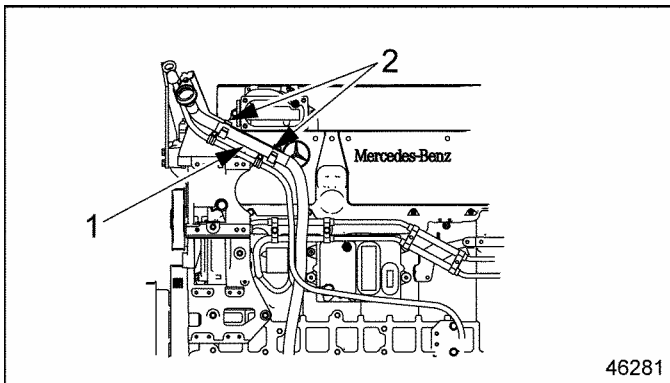

- | | |
|------------------|-------------------------|
| 1. Oil Fill Tube | 2. Oil Fill Tube Clamps |
|------------------|-------------------------|

Figure 5 Installing Oil Fill Tube

10. Connect oil fill neck flange to fill / dipstick bracket using one M6 x 16 bolt (P/N: N 910 105 00 60 04). Torque to 9 N·m (6.6 lb·ft). See figure 6.

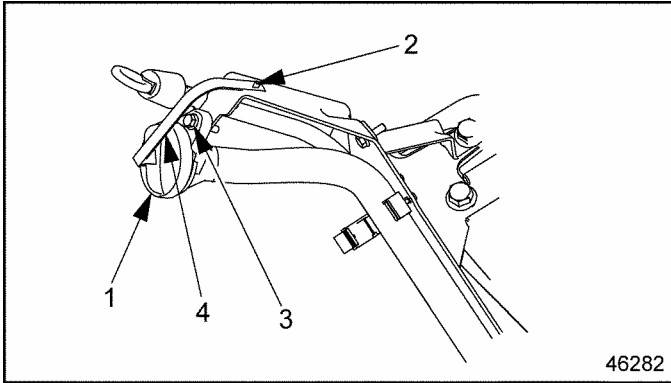

- | | |
|-----------------|--------------------------------|
| 1. Oil Fill Cap | 3. Oil Fill Neck Bolt, M6 x 16 |
| 2. Rivet | 4. Oil Cap Strap |

Figure 6 Attaching Oil Fill Neck & Strap to Bracket

11. Install oil fill cap (P/N: 344 018 03 68) and oil cap strap (P/N: 352 018 67 40), using rivet (P/N: N 007 337 00 40 09) to fasten strap to bracket hole. See Figure 6.
12. Fasten the oil fill tube to dipstick guide tube with double cable tie strap (P/N: 23535543). Clip tie ends after tightening. See Figure 7.

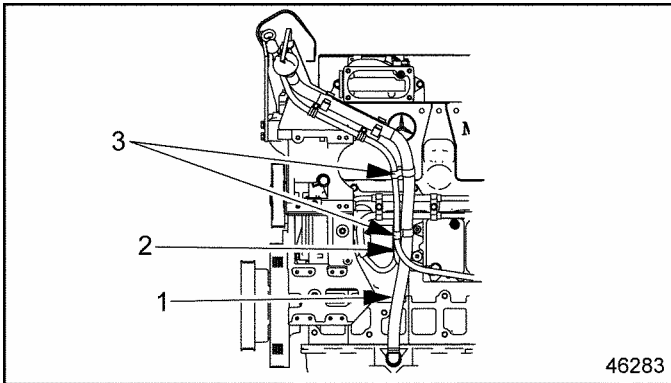

- | | |
|------------------------|------------------------------------|
| 1. Oil Fill Tube | 3. Double Cable Tie Strap (2 qty.) |
| 2. Dipstick Guide Tube | |

Figure 7 Attaching Double Cable Tie Strap



13400 Outer Drive, West
 Detroit, MI 48239-4001
 Telephone: 313.592.5000
 www.detroitdiesel.com

Copyright© 2005 Detroit Diesel Corporation. Detroit Diesel®, DDC®, and the spinning arrows design are registered trademarks of Detroit Diesel Corporation. All other trademarks are the property of their respective owners.
18SP616 0509 As technical advances continue, specifications will change. All rights reserved. Printed in U.S.A.