

STANDARD DRAWING OPTIONS	
REGULATOR:	
<input type="checkbox"/>	DVR2000E+
<input type="checkbox"/>	VOLTAGE ADJUST TOGGLE
<input type="checkbox"/>	SE350/MAVC63 OR PM300
<input type="checkbox"/>	VOLTAGE ADJUST RHEOSTAT
BREAKER OPTIONS:	
<input type="checkbox"/>	BELL ALARM INDICATION ON DGC-2020
<input type="checkbox"/>	GROUND FAULT MONITOR
<input type="checkbox"/>	OVERCURRENT WIRED TO DGC-2020
DC ACCESSORIES:	
<input type="checkbox"/>	DC HOUSING LIGHTS
<input type="checkbox"/>	FOUR RELAY OPTION
<input type="checkbox"/>	FUEL LEVEL GAUGE SENDER
<input type="checkbox"/>	FUEL LEAK SWITCH
<input type="checkbox"/>	MODBUS
GOVERNOR:	
<input type="checkbox"/>	WITHOUT GOVERNOR SPEED ADJUST
<input type="checkbox"/>	WITH GOVERNOR SPEED ADJUST
EMERGENCY STOP	
<input type="checkbox"/>	PANEL DOOR MOUNTED
<input type="checkbox"/>	PANEL DOOR MOUNTED & REMOTE MOUNTED
<input type="checkbox"/>	PANEL DOOR MOUNTED & A BREAK GLASS STATION
MODULES	
<input type="checkbox"/>	CONTACT EXPANSION MODULE
<input type="checkbox"/>	LOAD SHARE MODULE
<input type="checkbox"/>	ANALOG EXPANSION MODULE
ANALOG METERS	
<input type="checkbox"/>	WITH ANALOG METER BOX
<input type="checkbox"/>	WITHOUT ANALOG METER BOX

LEGEND

AL	ALARM BUZZER
AEM	ANALOG EXPANSION MODULE
BPS	BACK PLATE STUD
CEM	CONTACT EXPANSION MODULE
DGC	DGC-2020 MICROPROCESSOR
DGS	DOOR CONTROL STUD
ECU	ENGINE CONTROL UNIT
EHC	ENGINE HARNESS CONNECTOR
ESP	EMERGENCY STOP BUTTON
F4	PANEL FUSE ABC 15A
F5	ECM FUSE ABC 20A
FLGS	FUEL LEVEL GAUGE SENDER
FLS	FUEL LEAK SWITCH
GGS	GENERATOR GROUND STUD
GSA	GOVERNOR SPEED ADJUST
K1	ENGINE RUN RELAY
K2	ENGINE FAIL RELAY
K3	MINOR ALARM RELAY
K6	LOUVER MOTOR RELAY
K8	REMOTE EMERGENCY STOP RELAY
LSM	LOAD SHARE MODULE
LWL	LOW WATER LEVEL PROBE
MEC	MODBUS/ETHERNET CONVERTER
R1	120 OHM 1/8 1% RESISTOR
R2	332 OHM 1/8 1% RESISTOR
R3	1000 OHM 1/8 1% RESISTOR
R4	500 OHM 1/8 1% RESISTOR
TB1	TERMINAL BLOCK 1 (FACE PANEL)
TB2	TERMINAL BLOCK 2 (BACK PLATE)
VAT	VOLTAGE ADJUST RHEOSTAT
VAR	VOLTAGE ADJUST TOGGLE

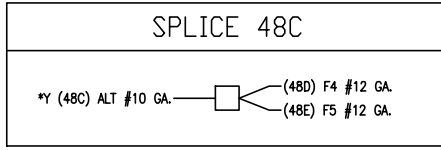
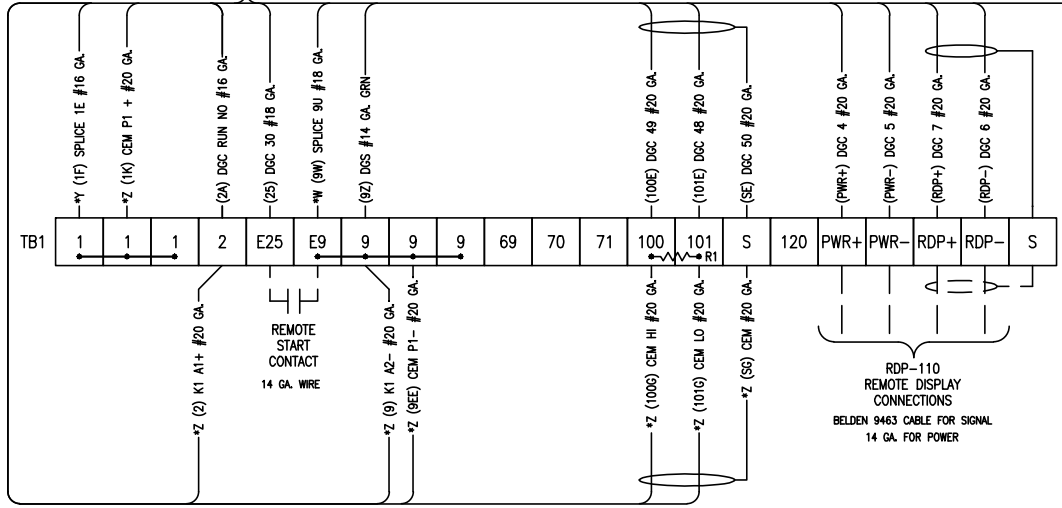
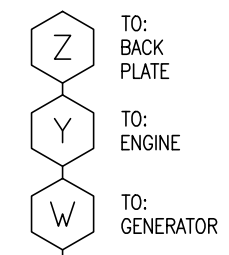

*X	(X)	XXX	X
*X	DESTINATION		
(X)	WIRE NUMBER		
XXX	DESTINATION		
X	DESTINATION TERMINAL		

- NOTES:
- WIRE NUMBERS ARE IN PARENTHESIS.
 - SHORT DASHED LINES (-----) INDICATE CUSTOMER CONNECTION OR OPTIONAL EQUIPMENT.

REV	REVISION DESCRIPTION	DATE	BY
<small>THIS DRAWING IS PROPERTY OF MTW ONSITE CORPORATION AND CANNOT BE USED EXCEPT IN CONNECTION WITH MTW ONSITE ENERGY CORPORATION POWER GENERATION PRODUCTS. ANY THIRD PARTY MODIFICATION MAY VOID THIS DRAWING. MTW ONSITE ENERGY CORPORATION RESERVES ALL RIGHTS OF THIS DRAWING.</small>			
SPECIAL NOTE		ENGINE: JOHN DEERE T3	
TO MINIMIZE ANY ELECTRICAL NOISE BEING INTRODUCED INTO THE ENGINE CONTROLLER, CONTROL WIRING AND AC POWER LINES NEED TO BE RUN IN SEPARATE CONDUITS.		GENERATOR: 12 WIRE	
		REGULATOR: DVR 2000E+	
		CONTROL PANEL: DGC-2020	
		VOLTAGE: 208V 3Ø	
		GOVERNOR: JDEC	
FACE PANEL DIAGRAM			
DATE: 10-2-13		DRAWING SIZE: B-SIZE	
DRAWN BY: DJG		SHEET: 1 OF 4	
809-Q-312212-F			

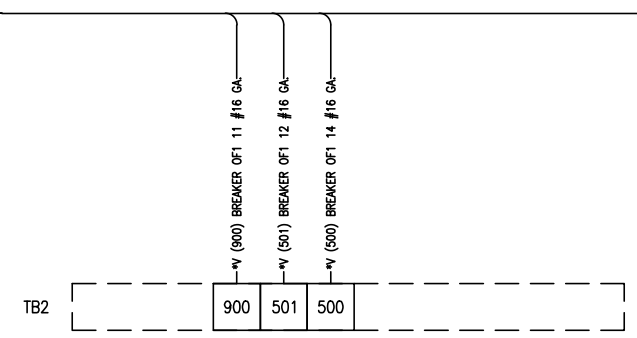
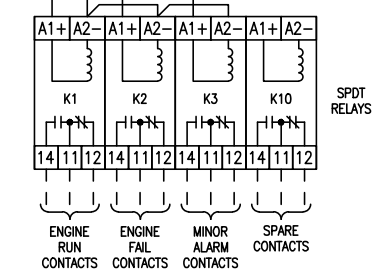
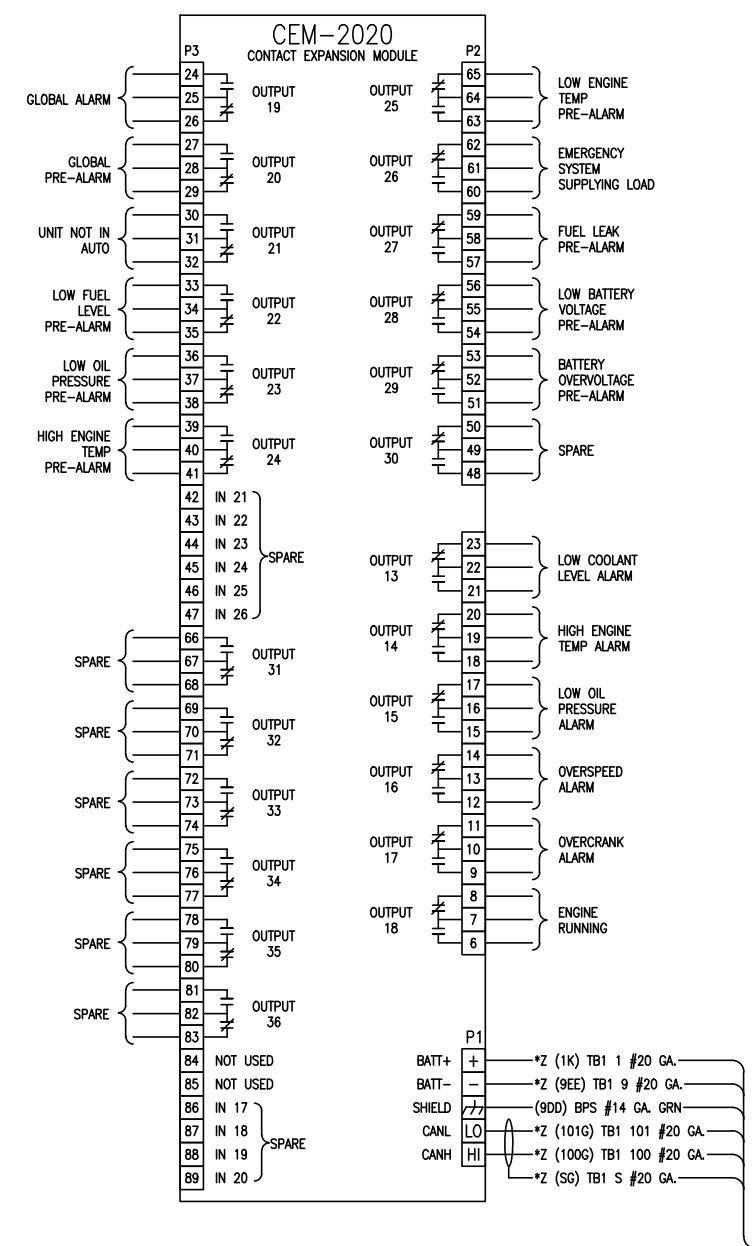
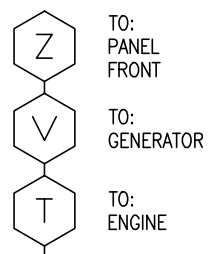

STANDARD DRAWING OPTIONS	
AC ACCESSORIES:	<input type="checkbox"/> LOUVER MOTORS
RTD:	<input type="checkbox"/> WIRED TO AEM
BREAKER OPTIONS:	<input checked="" type="checkbox"/> AUXILIARY SWITCH <input type="checkbox"/> BELL ALARM TO TB2 <input type="checkbox"/> SHUNT TRIP
DC ACCESSORIES:	<input type="checkbox"/> DC HOUSING LIGHTS <input checked="" type="checkbox"/> FOUR RELAY OPTION <input type="checkbox"/> MODBUS
MODULES	<input checked="" type="checkbox"/> CONTACT EXPANSION MODULE <input type="checkbox"/> ANALOG EXPANSION MODULE

LEGEND:

AEM	ANALOG EXPANSION MODULE
BPS	BACK PLATE STUD
CEM	CONTACT EXPANSION MODULE
DGC	DGC-2020 MICROPROCESSOR
DGS	DOOR GROUND STUD
K1	ENGINE RUN RELAY
K2	ENGINE FAIL RELAY
K3	MINOR ALARM RELAY
K10	SPARE RELAY
K6	LOUVER MOTOR RELAY
MEC	MODBUS/ETHERNET CONVERTER
R1	RESISTOR 120 OHM 1/8 W
TB1	TERMINAL BLOCK 1

REV	REVISION DESCRIPTION	DATE	BY



THIS DRAWING IS PROPERTY OF MTR ONSITE CORPORATION AND CANNOT BE USED EXCEPT IN CONNECTION WITH MTR ONSITE CORPORATION POWER GENERATION PRODUCTS. ANY THIRD PARTY MODIFICATION MAY VOID THIS DRAWING. MTR ONSITE ENERGY CORPORATION RESERVES ALL RIGHTS OF THIS DRAWING.

SPECIAL NOTE TO MINIMIZE ANY ELECTRICAL NOISE BEING INTRODUCED INTO THE ENGINE CONTROLLER, CONTROL WIRING AND AC POWER LINES NEED TO BE RUN IN SEPARATE CONDUITS.	ENGINE: JOHN DEERE T3 GENERATOR: 12 WIRE REGULATOR: DVR 2000E+ CONTROL PANEL: DGC-2020 VOLTAGE: 208V 3Ø GOVERNOR: JDEC
---	---

BACK PLATE DIAGRAM

DATE: 10-2-13	DRAWING SIZE: B-SIZE
DRAWN BY: DJG	SHEET: 2 OF 4

809-Q-312212-B

*X	DESTINATION
(X)	WIRE NUMBER
XXX	DESTINATION
X	DESTINATION TERMINAL

- NOTES:
- WIRE NUMBERS ARE IN PARENTHESIS.
 - SHORT DASHED LINES (-----) INDICATE CUSTOMER CONNECTION OR OPTIONAL EQUIPMENT.

- NOTES:
1. WIRE NUMBERS ARE IN PARENTHESIS.
 2. SHORT DASHED LINES (-----) INDICATE CUSTOMER CONNECTION OR OPTIONAL EQUIPMENT.
 3. BATTERY CHARGER FUSE ONLY WHEN REQUIRED OR SUPPLIED BY CHARGER MANUFACTURER.
 4. FUEL LEVEL GAUGE SENDER REQUIREMENTS:
33 OHMS = FULL
240 OHMS = EMPTY
 5. BATTERY CHARGER FUSE ONLY WHEN SUPPLIED OR REQUIRED BY CHARGER MANUFACTURER.

*X	(X)	XXX	X
*X			DESTINATION
(X)			WIRE NUMBER
XXX			DESTINATION
X			DESTINATION TERMINAL

STANDARD DRAWING OPTIONS	
DC ACCESSORIES:	
<input type="checkbox"/>	BATTERY CHARGER
<input type="checkbox"/>	DC HOUSING LIGHTS
<input type="checkbox"/>	FUEL LEVEL GAUGE SENDER
<input type="checkbox"/>	FUEL LEAK SWITCH
EMERGENCY STOP	
<input type="checkbox"/>	PANEL DOOR MOUNTED
<input type="checkbox"/>	PANEL DOOR MOUNTED & REMOTE MOUNTED
<input type="checkbox"/>	PANEL DOOR MOUNTED & A BREAK GLASS STATION

LEGEND

BC	BATTERY CHARGER
BPS	BACK PLATE STUD
DGC	DGC-2020 MICROPROCESSOR
DGS	DOOR GROUND STUD
DLC	DATA LINK CONNECTOR
ECU	ENGINE CONTROL UNIT
EHC2	ENGINE HARNESS CONNECTOR
F4	PANEL FUSE ABC 15A
F5	ECM FUSE ABC 20A
FLGS	FUEL LEVEL GAUGE SENDER
FLS	FUEL LEAK SWITCH
GGS	GENERATOR GROUND STUD
K1A	LOUVER MOTOR RELAY
K8	REMOTE EMERGENCY STOP RELAY
LWL	LOW WATER LEVEL PROBE
TB1	TERMINAL BLOCK 1
TB2	TERMINAL BLOCK 2 (UPPER PANEL BACK)
TB6	TERMINAL BLOCK 6 (DC LIGHTS HANDY BOX)
TRP	TERMINATING RESISTOR PLUC
SM	STARTER MOTOR

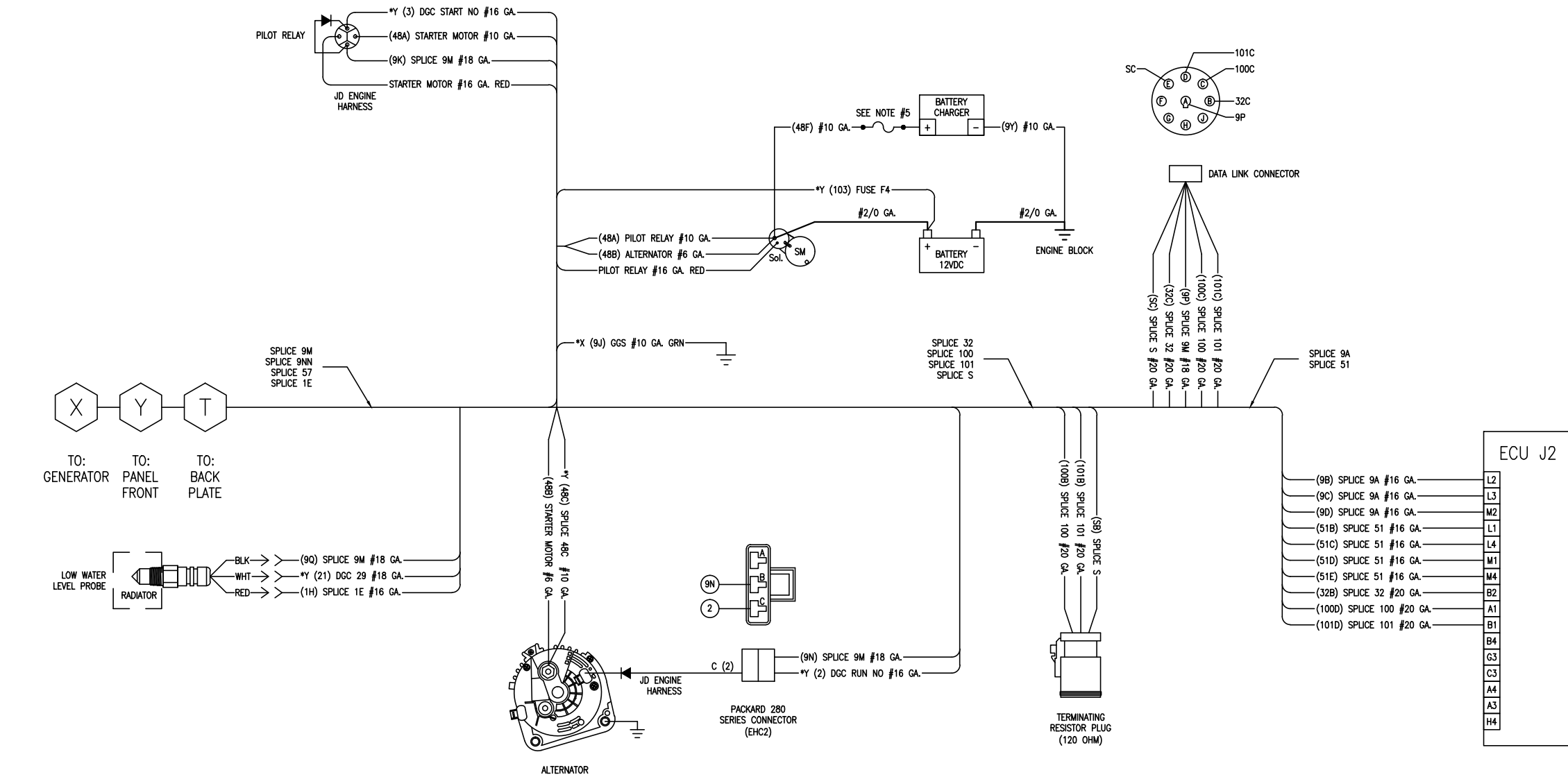

<p>SPLICE 1E</p> <p>*Y (1E) F4 #16 GA. *Y (1F) TB1 1 #16 GA. *Y (1G) DGC 3 #16 GA.</p> <p>(1H) LWL #16 GA.</p>	<p>SPLICE 9A</p> <p>*X (9A) GGS #12 GA.</p> <p>(9B) ECU L2 #16 GA. (9C) ECU L3 #16 GA. (9D) ECU M2 #16 GA.</p>	<p>SPLICE 9M</p> <p>*X (9M) GGS #12 GA.</p> <p>(9N) EHC2 B #18 GA. (9P) DLC A #18 GA. (9Q) LWL #18 GA. (9K) PILOT RELAY #18 GA.</p>	<p>SPLICE 9NN</p> <p>*X (9NN) GGS #16 GA.</p> <p>(9R) FLS #18 GA. (9MM) FLGS #18 GA.</p>	<p>SPLICE 32</p> <p>*Y (32A) DGC PRE NO #18 GA.</p> <p>(32B) ECU B2 #20 GA. (32C) DLC B #20 GA.</p>	<p>SPLICE 51</p> <p>*Y (51A) F5 #12 GA.</p> <p>(51B) ECU L1 #16 GA. (51C) ECU L4 #16 GA. (51D) ECU M1 #16 GA. (51E) ECU M4 #16 GA.</p>
<p>SPLICE 57</p> <p>*Y (57B) DGC 28 #18 GA.</p> <p>(57A) FLS #18 GA.</p>	<p>SPLICE 98</p> <p>*Y (98B) DGC 9 #18 GA.</p> <p>(98A) FLGS #18 GA.</p>	<p>SPLICE 100</p> <p>*Y (100A) DGC 49 #20 GA.</p> <p>(100B) TRP A #20 GA. (100C) DLC C #20 GA. (100D) ECU A1 #20 GA.</p>	<p>SPLICE 101</p> <p>*Y (101A) DGC 48 #20 GA.</p> <p>(101B) TRP B #20 GA. (101C) DLC D #20 GA. (101D) ECU B1 #20 GA.</p>	<p>SPLICE S</p> <p>*Y (SA) DGC 50 #20 GA.</p> <p>(SB) TRP C #20 GA. (SC) DLC E #20 GA.</p>	

REV	REVISION DESCRIPTION	DATE	BY
THIS DRAWING IS PROPERTY OF MTU ONSITE CORP. AND CANNOT BE USED EXCEPT IN CONNECTION WITH MTU ONSITE ENERGY CORP. POWER GENERATION PROJECTS. ANY THIRD PARTY MODIFICATION MAY VOID THIS DRAWING. MTU ONSITE ENERGY CORP. RESERVES ALL RIGHTS OF THIS DRAWING.			
SPECIAL NOTE		ENGINE: JOHN DEERE T3	
TO MINIMIZE ANY ELECTRICAL NOISE BEING INTRODUCED INTO THE ENGINE CONTROLLER, CONTROL WIRING AND AC POWER LINES NEED TO BE RUN IN SEPARATE CONDUITS.		GENERATOR: 12 WIRE	
		REGULATOR: DVR 2000E+	
		CONTROL PANEL: DGC-2020	
		VOLTAGE: 208V 3Ø	
		GOVERNOR: JDEC	
ENGINE DIAGRAM			
DATE: 10-2-13		DRAWING SIZE: B-SIZE	
DRAWN BY: DJG		SHEET: 4 OF 4	
809-Q-312212-E			

GENERATOR OUTLET BOX

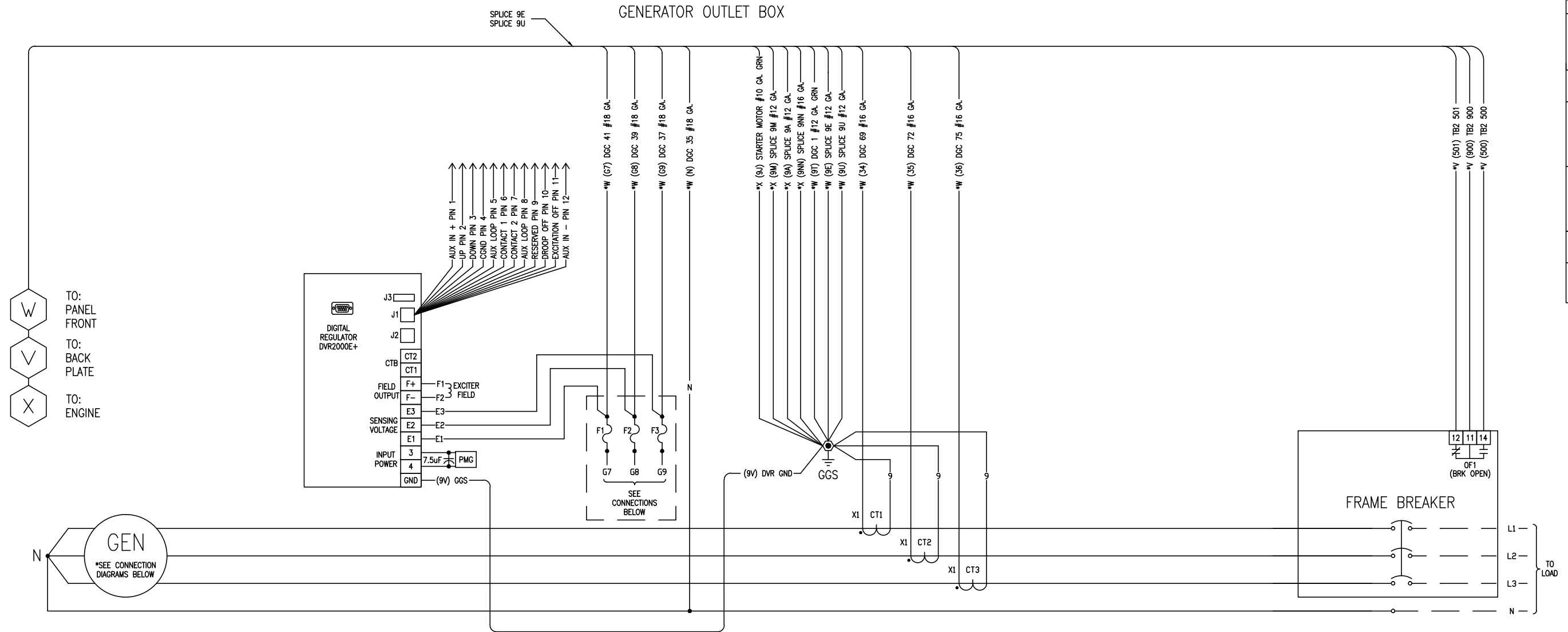

- STANDARD DRAWING OPTIONS**
- REGULATOR:**
- DVR2000E+
 - VOLTAGE ADJUST TOGGLE
 - CROSS CURRENT CT
 - SE350/MAVC63 OR PM300
 - VOLTAGE ADJUST RHEOSTAT
- RTD:**
- WIRED TO AEM
 - WIRED TO HANDY BOX
- AC ACCESSORIES:**
- WATER HEATER
 - WATER HEATER - 240VAC OR 208VAC
 - GENERATOR STRIP HEATER
 - AC HOUSING LIGHTS
 - LOUVER MOTORS
 - BATTERY CHARGER
- BREAKER OPTIONS:**
- AUXILIARY SWITCH TO TB2
 - AUXILIARY SWITCH INDICATION ON DGC-2020
 - BELL ALARM TO TB2
 - BELL ALARM INDICATION ON DGC-2020
 - GROUND FAULT MONITOR
 - SHUNT TRIP
- ANALOG METERS**
- WITH ANALOG METER BOX
 - WITHOUT ANALOG METER BOX
- VOLTAGE**
- 208 VOLT 3 PHASE 12 WIRE
 - 240 VOLT 3 PHASE 12 WIRE
 - 480 VOLT 3 PHASE 12 WIRE

- LEGEND**
- A AMMETER
 - AEM ANALOG EXPANSION MODULE
 - DGC DGC-2020 MICROPROCESSOR
 - DVR DIGITAL VOLTAGE REGULATOR
 - F1-3 KTK-10 OR JX-10 10A
 - GFM GROUND FAULT MONITOR
 - GGS GENERATOR GROUND STUD
 - Hz FREQUENCY METER
 - K1A LOUVER MOTOR RELAY
 - M LOUVER MOTOR
 - MN UNDERVOLTAGE TRIP
 - MX SHUNT TRIP
 - OF1 AUXILIARY SWITCH 1
 - OF2 AUXILIARY SWITCH 2
 - SD ALARM SWITCH
 - SDE OVERCURRENT TRIP SWITCH
 - TB1 TERMINAL BLOCK 1 (PANEL DOOR)
 - TB2 TERMINAL BLOCK 2 (PANEL BACK)
 - TB4 TERMINAL BLOCK 4 (HANDY BOX)
 - V VOLTMETER

- TO: PANEL FRONT
- TO: BACK PLATE
- TO: ENGINE

- NOTE:**
1. WIRE NUMBERS ARE IN PARENTHESIS.
 2. SHORT DASHED LINES (-----) INDICATE CUSTOMER CONNECTION.
 3. BREAKER ACCESSORIES ARE SHOWN IN THE TRIPPED OR OPEN POSITION.

*X	(X)	XXX	X
*K	DESTINATION		
(X)	WIRE NUMBER		
XXX	DESTINATION		
X	DESTINATION TERMINAL		

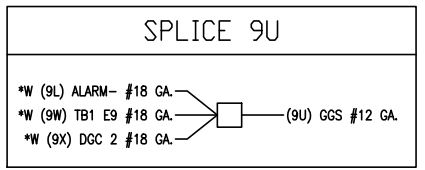
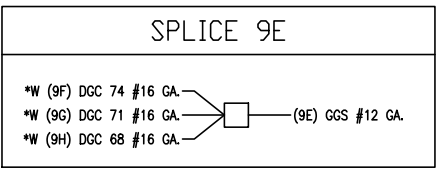
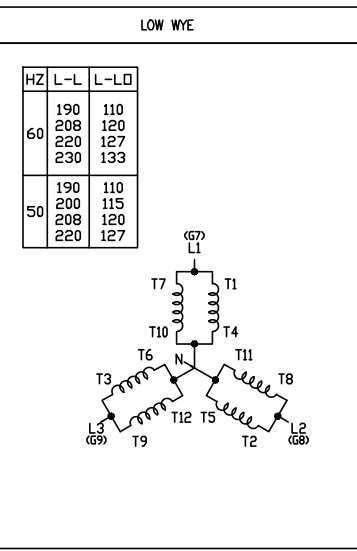

CUSTOMER CONNECTIONS

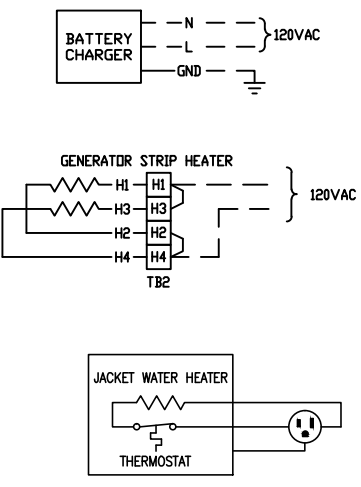

REV	REVISION DESCRIPTION	DATE	BY
<p>**SPECIAL NOTE**</p> <p>TO MINIMIZE ANY ELECTRICAL NOISE BEING INTRODUCED INTO THE ENGINE CONTROLLER, CONTROL WIRING AND AC POWER LINES NEED TO BE RUN IN SEPARATE CONDUITS.</p>			
ENGINE: JOHN DEERE T3		REGULATOR: DVR 2000E+	
GENERATOR: 12 WIRE		CONTROL PANEL: DGC-2020	
VOLTAGE: 208V 3Ø		GOVERNOR: JDEC	
<h2>GENERATOR DIAGRAM</h2>			
DATE: 10-2-13		DRAWING SIZE: B-SIZE	
DRAWN BY: DJG		SHEET: 3 OF 4	
<h1>809-Q-312212-G</h1>			

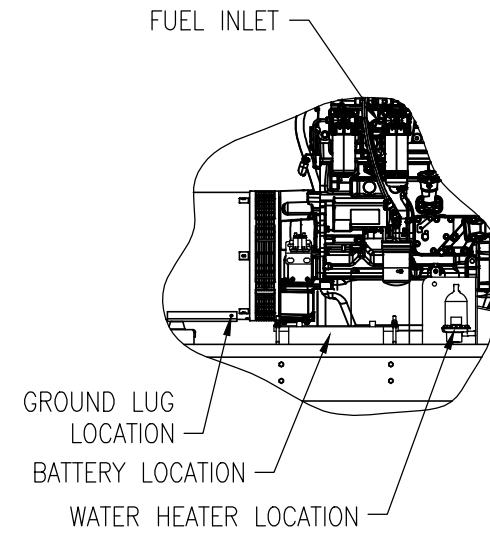
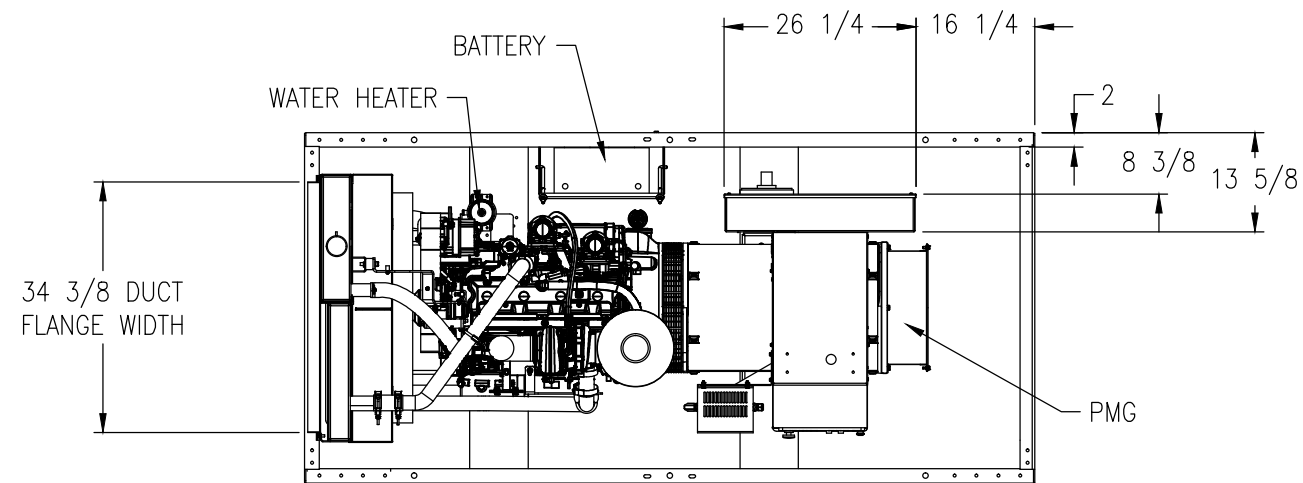

NOTES:

1. SUB-BASE FUEL TANK INFORMATION:
OVERALL HEIGHT OF UNIT WILL INCREASE WITH USE OF OPTIONAL SUB-BASE FUEL TANK. REFERENCE SALES CATALOG FOR TANK HEIGHT AND GALLON CAPACITY INFORMATION.
2. FUEL SYSTEM CONNECTIONS:
(FOR UNITS WITHOUT SUB-BASE FUEL TANKS)
INLET: 3/8 NPT OUTLET: 3/8 NPT
3. APPROX. UNIT WEIGHT: (WET) 3,300# / LESS FUEL
4. UNIT IS ***IBC-UL2200***

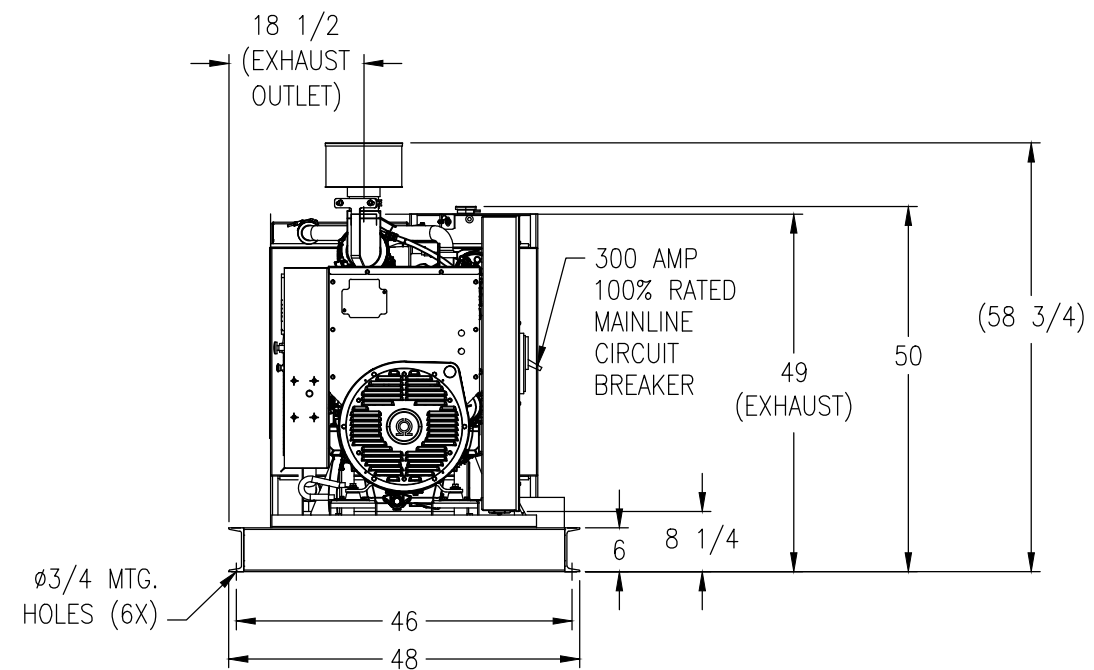
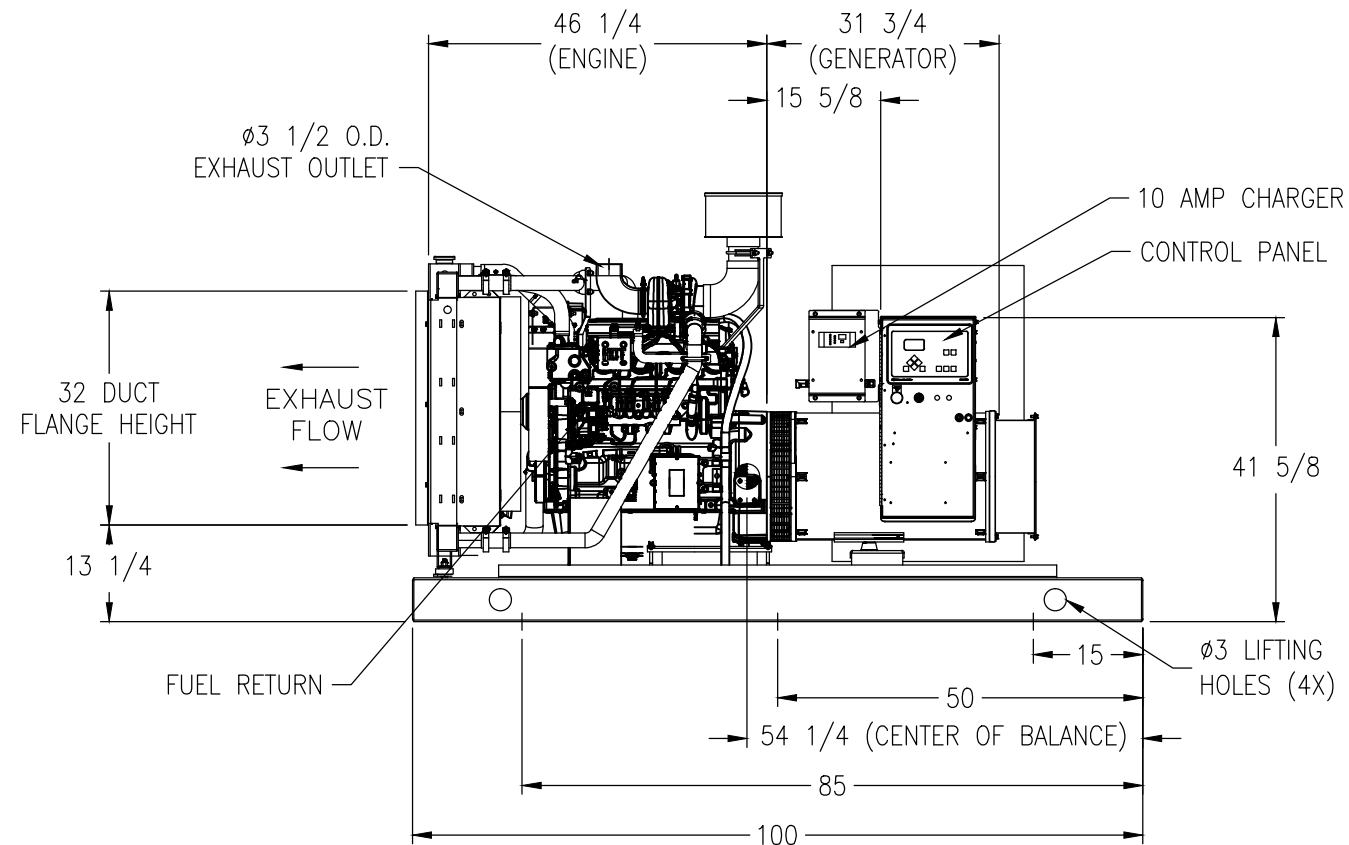

DRAWING TOLERANCES: ±1/4"
EXCEPT BASE MTG. HOLES: ±1/8"

REVISION	DATE	REVISION DESCRIPTION	INITIALS
A	09-26-13	INITIAL RELEASE TO SALES AND ENGINEERING (REF. QUOTE 312212)	JTG



THIS DRAWING IS PROPERTY OF MTU ONSITE ENERGY CORPORATION AND CANNOT BE USED EXCEPT IN CONNECTION WITH MTU ONSITE ENERGY CORPORATION POWER GENERATION PROJECTS. ANY THIRD PARTY MODIFICATION MAY VOID THIS DRAWING. MTU ONSITE ENERGY CORPORATION RESERVES ALL RIGHTS OF THIS DRAWING.

GEN-SET INFORMATION

ENGINE: 4045HF285	ENCLOSURE: NA
GENERATOR: 363 W/ PMG	BREAKER: 300 AMP
RADIATOR: 96373(DR-3350)	TANK: NA
RADIATOR AMBIENT: 50C	MUFFLER: NA
DUCT FLANGE: 96135	TRAILER: NA
CONTROL PANEL: DGC-2020	ISOLATORS: PADS
BASE: 97749	

DIMENSIONAL LAYOUT

DRAWN TO SCALE ALL DIMENSIONS ARE IN INCHES	MODEL: DS125D6SPA
DATE: 09-26-13	DRAWN BY: JTG

DWG. #: DS125D6SPA(4045HF)LO-MD-181

