

The following pushbuttons may be provided:

Channel	Name	Type	PV	Description/function
DI1	ENGINE STOP	Pushbutton	2.7001.800	Pressing the pushbutton trips the stopping sequence without switching off the Engine Control Unit.
DI2	SWITCH SPEED DROOP	Switch	2.1060.830	Switches between two speed droop settings.
DI3	SWITCH 50/60HZ	Switch	2.7003.800	Switches between two generator frequencies 50Hz and 60Hz.
DI4	ALARM RESET	Pushbutton	2.8009.021	Pressing the pushbutton switches alarm signaling off. Pressing the pushbutton acknowledges the alarm.
DI5	SPEED UP	Pushbutton	2.1060.800	Pressing the pushbutton increases engine speed.
DI6	SPEED DOWN	Pushbutton	2.1060.810	Pressing the pushbutton decreases engine speed.
DI7	START	Pushbutton	2.1090.800	Pressing the pushbutton trips the automatic engine start sequence.
DI8	OVERRIDE	Pushbutton	2.7002.800	Pressing the pushbutton temporarily bypasses the safety system.

2.3.2.2 Alarm indicator lamps

The alarm indicator lamps provide information about the operating state of the engine.

Channel	Color	Inscription	Meaning/function
TOP1	Yellow	YELLOW ALARM	Summary alarm indicator lamp, lights up when a so-called "yellow alarm" has been tripped, engine power may be reduced automatically.
TOP2	Red	RED ALARM	Summary alarm indicator lamp, lights up when a so-called "red alarm" has been tripped, engine may be shut down automatically.

2.3.2.3 Indicator lamp

The indicator lamp provides information about the starting state of the engine

Channel	Color	Inscription	Meaning/function
TOP3	Red	LUBE OIL STOP	Oil pressure too low
TOP4	Green	Starter ON	Activation of the starter

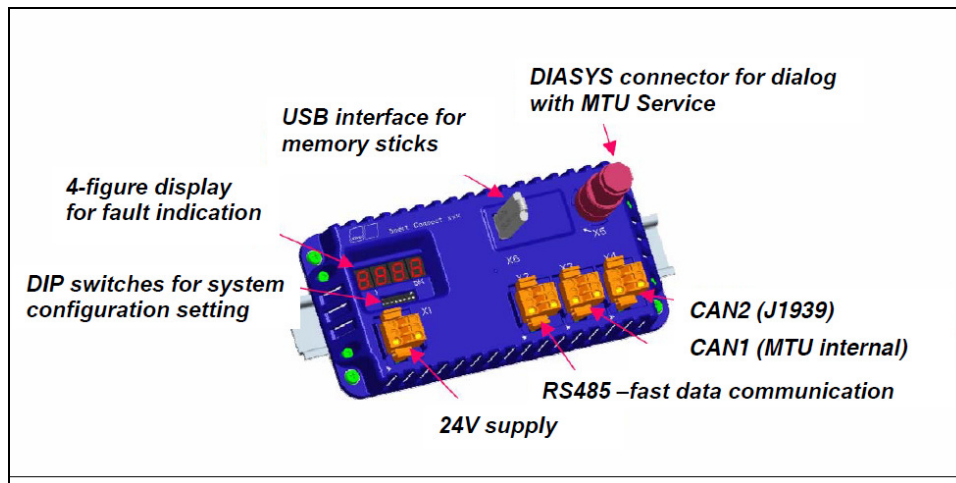

Speed demand is set as follows:

1	1	1
1	2	3
0	0	0

Speed demand

The speed demand can be set using the three switches (i.e. 8 variants)

Switch default settings:

000 = 0 = ECU parameter default settings = Speed demand up/down direct
(variants 1 and 2 would thus be identical)

Variante	Code	Designation	Function
1	000 = 0	ECU default	ECU default settings of the 4 internal speed demand switches (→ default speed up / down) default
2	001 = 1	ECU direct up / down	The speed demand (up / down) controlled over binary inputs directly at the ECU. Settings can be done via DiaSys at the ECU.
3	010 = 2	ECU analogue relative	The analogue speed demand controlled over analogue inputs directly at the ECU. Settings can be done via DiaSys at the ECU. 0 Volt = -100rpm 5 Volt = +100rpm
4	011 = 3	ECU analogue relative	The analogue speed demand controlled over analogue inputs directly at the ECU. Settings can be done via DiaSys at the ECU. 0 Volt = -100rpm 10 Volt = +100rpm
5	100 = 4	ECU analogue relative	The analogue speed demand controlled over analogue inputs directly at the ECU. Settings can be done via DiaSys at the ECU. 4 mA = -100rpm 20 mA = +100rpm
6	101 = 5	CAN analogue	The speed demand value (unit: rpm) will be transferred via CAN Bus from SAM to the ECU. The speed demand information must be received from an external CAN Bus (CANopen or SAE J1939).
7	110 = 6	CAN up / down	The speed demand (up / down) will be transferred over CAN Bus from SAM to the ECU. The speed demand information must be received from an external CAN Bus (CANopen or SAE J1939).
8	111 = 7	External Speed Demand source	The speed demand is flexible, the speed demand source can be transmitted from an external controller

Achtung hierfür sind zwei Kurven notwendig

The figure below shows the assignment of the 8 DIP switches.

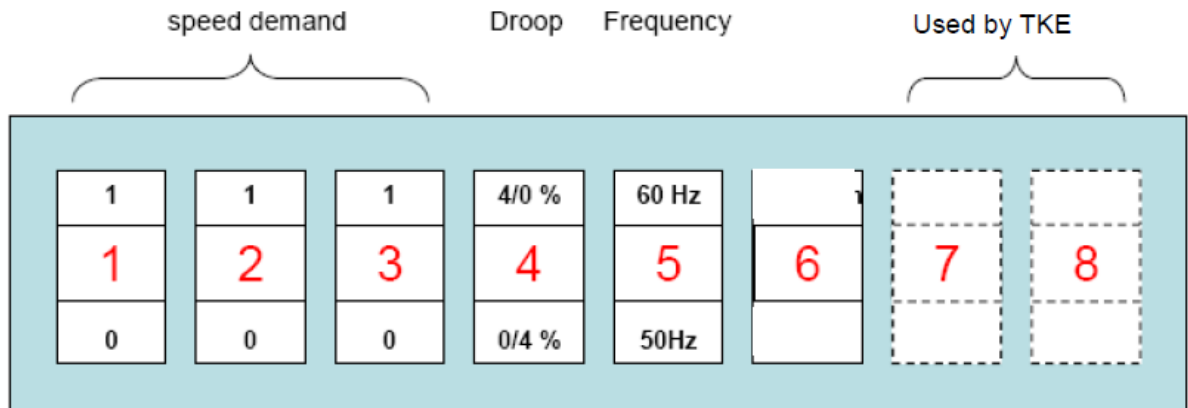

BESTCOMSPPlus - [DGC-2020 - SettingsFile2]

File Communication Tools Window Help

View Open File Disconnect Preview Metering Export Metering Options **LIVE MODE**

Settings Explorer

- DGC-2020
 - General Settings
 - Communications
 - CANBus
 - CANBus Setup
 - ECU Setup**
 - Modem Setup
 - RS485 Setup
 - System Parameters
 - Programmable Inputs
 - Programmable Outputs
 - Configurable Protection
 - Alarm Configuration
 - Generator Protection
 - Breaker Management
 - Bias Control Settings
 - Multigen Management
 - Programmable Senders
 - BESTLogicPlus Programmable

ECU Setup

ECU Setup

ECU Type: MTU Smart Connect

Generator Parameter Transmit: Disable

Engine Parameter Transmit: Enable

Diesel Particulate Filter (DPF)

Manual Regeneration: Off

Disable Regeneration: Off

Speed Setup

CANBus RPM Request: Enable

Engine RPM: 1803

Idle RPM: 800

RPM Bandwidth: 100

Volvo Penta

Speed Select: Primary

Accelerator Position (%): 50

MTU (MDEC, ADEC, ECU7/ECU8)

MTU ECU7/ECU8 Module Type: 501

MDEC Module Type: CAN Module 303

NMT Alive Transmit Rate (msec): 500

Speed Configuration

Speed Demand Switch: Analog CAN

Overspeed Test: Off

Speed Up

Speed Down

Idle Request: Off

Increased Idle: 0

MTU 50 Hz 60 Hz Switch Setting: 50 Hz

ECU Configuration

Trip Reset

Int Oil Prime

Engine Start Prime: Off

Fan Override: Off

Mode Switch: Off

Governor Param Switch Over: Off

Governor Param Set Select: 0

ECU Setup Setting Information

DGC-2020.Communications.CANBus.ECU Setup

ONLINE