

MTU_ValueService

Technical
Documentation

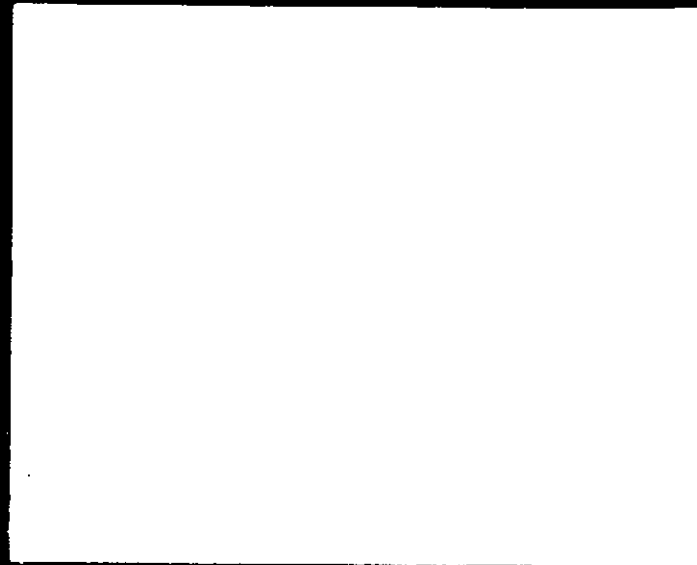

MTU_ValueService **Technical Documentation**

Diesel Engine
20 V 4000 G23
20 V 4000 G43
20 V 4000 G63
20 V 4000 G83

Operating Instructions
M015715/01E



Printed in Germany

© 2009 Copyright MTU Friedrichshafen GmbH

This Publication is protected by copyright and may not be used in any way whether in whole or in part without the prior written permission of MTU Friedrichshafen GmbH. This restriction also applies to copyright, distribution, translation, microfilming and storage or processing on electronic systems including data bases and online services. This handbook is provided for use by maintenance and operating personnel in order to avoid malfunctions or damage during operation.

Subject to alterations and amendments.

Wichtig – Important – Importante

Bitte die Karte „Inbetriebnahmemeldung“ abtrennen und ausgefüllt an MTU Friedrichshafen GmbH zurücksenden.

Die Informationen der Inbetriebnahmemeldung sind Grundlage für den vertraglich vereinbarten Logistik-Support (Gewährleistung, Ersatzteile etc.).

Please complete and return the “Commissioning Note” card below to MTU Friedrichshafen GmbH.

The Commissioning Note information serves as a basis for the contractually agreed logistic support (warranty, spare parts, etc.).

Veillez séparer la carte “Signalisation de mise en service” et la renvoyer à la MTU Friedrichshafen GmbH.

Les informations contenues dans la signalisation de mise en service constituent la base pour l'assistance en exploitation contractuelle (garantie, rechanges, etc.).

Rogamos separen la tarjeta “Aviso de puesta en servicio” y la devuelvan rellena a MTU Friedrichshafen GmbH.

Las informaciones respecto al aviso de puesta en servicio constituyen la base para el soporte logístico contractual (garantía, piezas de repuesto, etc.).

Ritagllare “Avviso di messa in servizio” e rispedirlo debitamente compilato alla MTU Friedrichshafen GmbH.

Le informazioni ivi registrate sono la base per il supporto logistico contrattuale (garanzia, ricambi, ecc.).

É gentileza cortar o cartão “Participação da colocação em serviço”, preenchê-lo e devolvê-lo a MTU Friedrichshafen.

Os dados referentes à colocação em serviço representam a base para o suporte logístico (garantia, peças sobressalentes, etc.) estabelecido contratualmente.

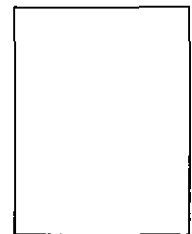

Postcard

MTU Friedrichshafen GmbH
Technical Information Management
88040 Friedrichshafen
GERMANY



Bitte in Blockschrift ausfüllen!
Please use block capitals!
Prière de remplir en lettres capitales!
¡A rellenar en letras de imprenta!
Scrivere in stampatello!
Favor preencher com letras de forma!



Motomr.:
 Engine No.:
 N° du moteur:
 N° de motor:
 Motore N.:
 No. do motor:

Auftragsnr.:
 MTU works order No.:
 N° de commande:
 N° de pedido:
 N. commessa:
 No. do pedido:

**Inbetriebnahme-
 meldung**

**Commissioning
 Note**

Motortyp:
 Engine model:
 Type du moteur:
 Tipo de motor:
 Motore tipo:
 Tipo do motor:

Inbetriebnahmedatum:
 Date put into operation:
 Mise en service le:
 Fecha de puesta en servicio:
 Messa in servizio il:
 Data da colocação em serviço:

**Notice de mise
 en service**

**Aviso de puesta
 en servicio**

Eingebaut in:
 Installation site:
 Lieu de montage:
 Lugar de montaje:
 Installato:
 Incorporado em:

Schiffstyp / Schiffshersteller:
 Vessel/type/class / Shipyard:
 Type du bateau / Constructeur:
 Tipo de buque / Constructor:
 Tipo di barca / Costruttore
 Tipo de embarcação/estaleiro naval:

**Avviso di messa
 in servizio**

**Participação da
 colocação em
 serviço**

Endabnehmer/Anschrift:
 End user's address:
 Adresse du client final:
 Dirección del cliente final:
 Indirizzo del cliente finale:
 Usuário final/endereço:

Bemerkung:
 Remarks:
 Remarques:
 Observaciones:
 Commento:
 Observações:

1	Safety	05
1.1	General conditions	05
1.2	Personnel and organizational requirements	06
1.3	Transport	07
1.4	Crankshaft transport locking device	08
1.5	Safety requirements when working on the engine	10
1.6	Auxiliary materials, fire prevention and environmental protection	13
1.7	Standards for warning notices in the publication	15
2	Product Summary	17
2.1	Engine Overview	17
2.1.1	Engine layout	17
2.1.2	Sensors, actuators and injectors – Overview	19
2.2	Engine Side and Cylinder Designations	23
2.2.1	Engine side and cylinder designations	23
2.3	Main Engine Dimensions	24
2.3.1	Main engine dimensions	24
2.4	Firing Sequence	25
2.4.1	Firing order	25
2.5	Final Compression Pressure	26
2.5.1	Final compression pressure	26
2.6	Technical Data	27
2.6.1	20V 4000 Gx3 engine data: Standby operation 3D, optimized fuel consumption	27
2.6.2	20V 4000 Gx3 engine data: Standby operation 3D, optimized exhaust emissions (EPA stage 2)	34
2.6.3	20V 4000 Gx3 engine data: Continuous operation, variable 3B, optimized fuel consumption	38
2.6.4	20V 4000 Gx3 engine data: Continuous operation variable 3B, optimized exhaust emissions (EPA2)	45
2.6.5	20V 4000 Gx3 engine data: Continuous operation, variable 3B, optimized exhaust emissions (TA-Luft)	49
3	Operation	53
3.1	Putting the engine into operation after extended out-of-service-periods (>3 months)	53
3.2	Putting the engine into operation after scheduled out-of-service-period	54
3.3	Start engine in manual mode (testing mode)	55
3.4	Bypassing the safety system (Override)	56
3.5	Starting the engine in emergency situations (override mode)	57
3.6	Operational checks	58
3.7	Stop engine in manual mode (testing mode)	59

3.8	Emergency stop	60
3.9	After stopping the engine – engine remains ready for operation	61
3.10	After stopping the engine – putting the engine out of service	62
3.11	Plant – Cleaning	63
4	Maintenance	65
4.1	Preface	65
4.2	Maintenance schedule matrix	67
4.3	Activities	68
4.4	Preface	70
4.5	Maintenance schedule matrix	71
4.6	Activities	72
5	Troubleshooting	75
5.1	Troubleshooting	75
5.2	Fault messages on the SAM display	78
5.3	Engine governor ADEC (ECU 7) for Series 4000 genset engines – Fault messages	79
6	Task Descriptions	131
6.1	Engine	131
6.1.1	Engine – Barring manually	131
6.1.2	Engine – Barring with starting system	132
6.1.3	Engine test run	133
6.2	Cylinder Liner	134
6.2.1	Cylinder liner – Endoscopic examination	134
6.2.2	Instructions and comments on endoscopic and visual examination of cylinder liners	136
6.3	Crankcase Breather	138
6.3.1	Crankcase breather – Oil separator replacement, diaphragm check and replacement	138
6.4	Valve Gear	140
6.4.1	Valve gear – Lubrication	140
6.4.2	Valve clearance – Check and adjustment	141
6.4.3	Cylinder head cover – Removal and installation	145
6.5	Fuel Injector	146
6.5.1	Injector – Replacement	146
6.5.2	Injector – Removal and Installation	147
6.6	Fuel System	152
6.6.1	Fuel system – Venting	152
6.7	Fuel Filter	153
6.7.1	Fuel filter – Replacement	153
6.7.2	Fuel prefilter cleaning	154
6.7.3	Fuel prefilter – differential pressure check and adjustment of gauge	155
6.7.4	Fuel prefilter – Draining	156

6.7.5	Fuel prefilter – Flushing	158
6.7.6	Fuel prefilter – filter element replacement	160
6.8	Charge-Air Cooling	162
6.8.1	Intercooler – Checking condensate drains for coolant discharge and obstructions	162
6.9	Air Filter	163
6.9.1	Air filter replacement	163
6.9.2	Air filter – Check	164
6.9.3	Air filter – Removal and installation	165
6.10	Air Intake	166
6.10.1	Service indicator – Signal ring position check	166
6.11	Starting Equipment	167
6.11.1	Air starter – manual operation	167
6.11.2	Starter – Condition check	168
6.12	Lube Oil System, Lube Oil Circuit	169
6.12.1	Engine oil – Level check	169
6.12.2	Engine oil – Change	170
6.12.3	Engine oil – Sample extraction and analysis	172
6.13	Oil Filtration / Cooling	173
6.13.1	Engine oil filter – Replacement	173
6.13.2	Centrifugal oil filter – Cleaning and filter-sleeve replacement	174
6.14	Coolant Circuit, General, HT Circuit	176
6.14.1	Engine coolant level – Check	176
6.14.2	Engine coolant – Change	177
6.14.3	Engine coolant – Draining	178
6.14.4	Engine coolant – Filling	179
6.14.5	Engine coolant pump – Relief bore check	182
6.14.6	Engine coolant – Sample extraction and analysis	183
6.15	LT Circuit	184
6.15.1	Charge-air coolant – Level check	184
6.15.2	Charge-air coolant – Change	185
6.15.3	Charge-air coolant – Draining	186
6.15.4	Charge-air coolant – Filling	187
6.15.5	Charge-air coolant pump – Relief bore check	190
6.16	Belt Drive	191
6.16.1	Drive belt – Condition check	191
6.17	Battery-Charging Generator	192
6.17.1	Battery-charging generator drive – Drive belt tension adjustment	192
6.17.2	Battery-charging generator drive – Drive belt replacement	193
6.18	Cabling, General for Engine / Gearbox / Unit	194
6.18.1	Engine wiring – Check	194
6.19	Accessories for Engine Governor (Electronic) / Control System	195
6.19.1	Engine governor and connectors – Cleaning	195
6.19.2	Engine governor plug-in connections – Check	196
6.19.3	Engine governor – Removal and installation	197

7	Special Tools	199
	7.1 Special tools	199
8	Appendix	209
	8.1 Manufacturer's documentation	209
	8.2 MTU-contact person/service partner	210
	8.3 Abbreviations	211
	8.4 Index	215

1 Safety

1.1 General conditions

General

In addition to the instructions in this publication, the applicable country-specific legislation and other compulsory regulations regarding accident prevention must be observed. This engine is a state-of-the art product and conforms with all applicable specifications and regulations. Nevertheless, persons and property may be at risk in the event of:

- Incorrect use
- Operation, maintenance and repair by unqualified personnel
- Modifications or conversions
- Non-compliance with the Safety Instructions

Correct use

The engine is intended exclusively for the application specified in the contract or defined at the time of delivery. Any other use is considered improper use. The manufacturer will accept no liability for any resultant damage. The responsibility is borne by the user alone.

Correct use also includes observation of and compliance with the maintenance specifications.

Modifications or Conversions

Modifications made by the customer to the engine may affect safety.

MTU will accept no liability or warranty claims for any damage caused by unauthorized modifications or conversions.

Spare parts

Only genuine MTU spare parts must be used to replace components or assemblies. In the event of any damage caused by the use of other spare parts, no liability nor warranty claims vis-à-vis the engine manufacturer will be accepted.

1.2 Personnel and organizational requirements

Personnel

Work on the engine must only be carried out by properly qualified and instructed personnel.

The specified legal minimum age must be observed.

Responsibilities of the operating, maintenance and repair personnel must be specified.

Organization

This publication must be issued to all personnel involved in operation, maintenance, repair or transportation.

It must be kept at hand near the engine and accessible at any time to all personnel involved in operation, maintenance, repair or transportation.

The personnel must be instructed on engine operation and repair by means of this publication, and in particular the safety instructions must be explained.

This is especially important for personnel who work on the engine only on an occasional basis. Such personnel must be given instructions repeatedly.

Working clothes and protective equipment

Wear proper work clothing for all work.

Depending on the kind of work, use additional protective equipment, e.g. protective goggles, gloves, helmet, apron.

Work clothing must be tight fitting so that it does not catch on rotating or projecting components.

Do not wear jewelry (e.g. rings, chains etc.).

1.4 Crankshaft transport locking device

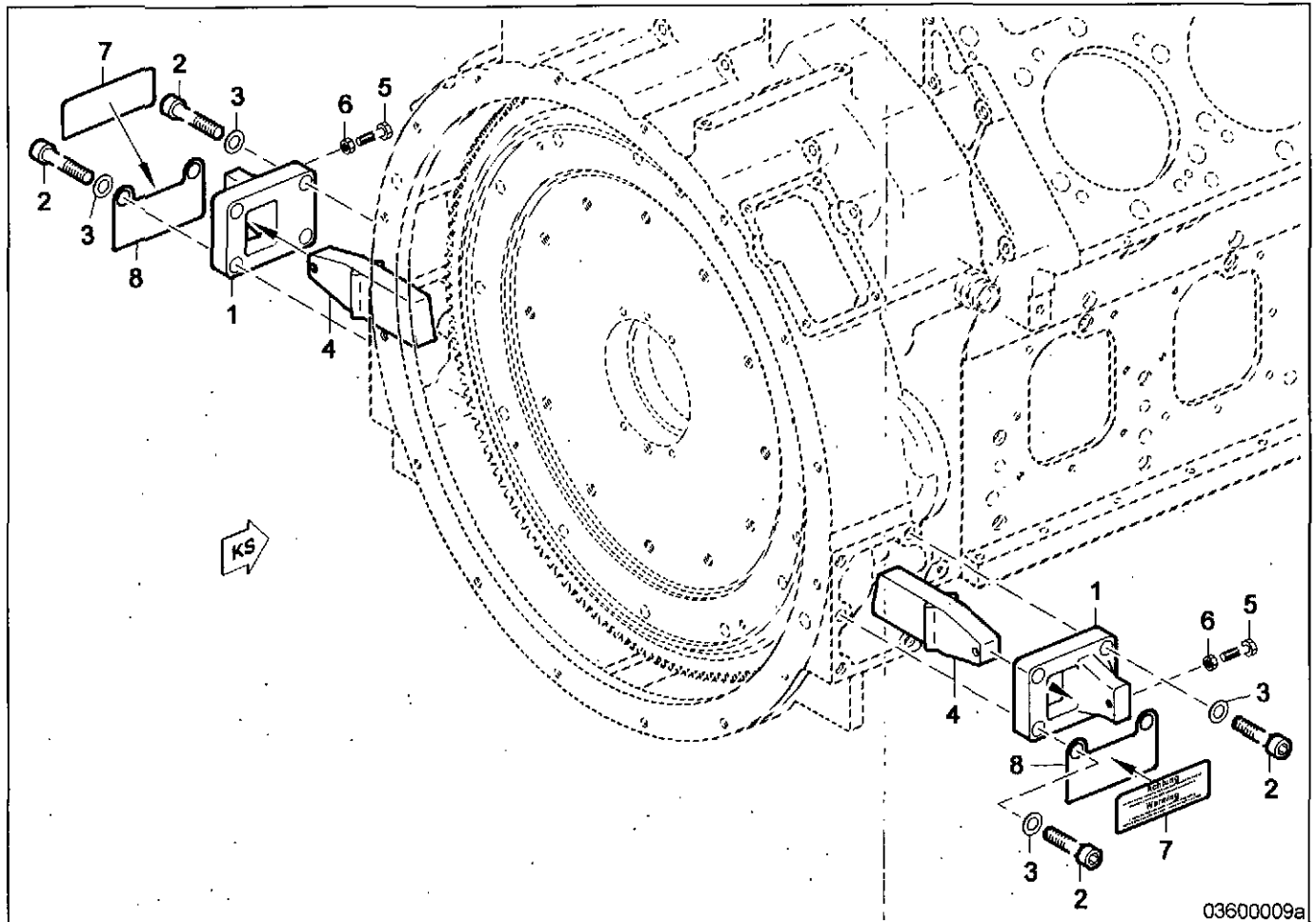

Transport locking device

This locking device protects the crankshaft bearings from shocks and vibration damage during engine transport.

For installation and removal of the transport locking device, follow the instructions below:

- The transport locking device should remain installed as long as possible during engine installation in order to avoid damage.
- Starting or barring the engine is allowed only with the transport locking device removed. If the generator is already mounted on the engine, ensure that the transport locking device of the generator is also removed.
- Prior to every engine transport (without generator), the transport locking device must be reinstalled according to the instructions.
- Prior to every engine transport, the transport locking device must be reinstalled according to the instructions. If the engine is to be moved together with the generator, the transport locking device for the generator must also be installed.

Removing the transport locking device from driving end (KS)

- Release the locknuts (6) on both sides of the flywheel housing, remove screws (5) and take off the two locks (4).
- Remove screws (2), washers (3), cover plate (8) with label (7) and plates (1).

Store the removed parts of the transport locking device carefully for possible reuse!

Fitting the transport locking device on driving end (KS)

- Secure the two plates (1) with screws (5) and nuts (6) together with cover plate (8) at the bores on both sides of the flywheel housing. Tightening torque: 250 Nm + 25 Nm, lubricant: engine oil.
- Screw nut (6) onto screws (5) up to the end of the thread.
- Fit the locks (4) through the openings of plates (1) and fasten with the screws (5).
- Tighten screws (5) in alternating steps on both sides. Tightening torque : 30 Nm + 3 Nm, lubricant: engine oil.

1.5 Safety requirements when working on the engine

Safety precautions when putting the equipment into operation

Prior to initial operation, the product must have been installed correctly and approved according to MTU specifications.

Before putting the device or the system into operation, always ensure

- that all maintenance and repair work is completed
- that all loose components have been removed from rotating parts
- that nobody is standing in the danger zone of moving engine components.

Immediately after putting the device or system into operation, make sure that all control and display instruments as well as the signaling and alarm systems work properly.

Safety requirements for operators

Procedures for cases of emergency must be practiced regularly.

The operator must be familiar with the controls and displays.

The operator must know the consequences of each operation to be carried out.

The operator must carry out the individual operations according to the documentation.

During operation, the displays and monitoring units must be permanently observed with regard to present operating status, violation of limit values and warning or alarm messages.

The following steps must be taken if a malfunction of the system is recognized or reported by the system:

- notify the supervisory personnel in charge
- analyze the message
- if required, carry out emergency operations e.g. emergency engine stop.

Engine operation

When the engine is running, always wear ear protectors.

Ensure that the engine room is well ventilated.

Mop up any leaked or spilt fluids and lubricants immediately or soak up with a suitable bonding agent.

Exhaust gases from combustion engines are poisonous. Inhalation of poisonous exhaust gases is a health hazard. The exhaust pipework must be free of leaks and discharge the gases to atmosphere.

During engine operation, do not touch battery terminals, generator terminals or cables.

Inadequate protection of electrical components can lead to electric shocks and serious injuries.

When the engine is running, never release coolant, oil, fuel, compressed-air or hydraulic lines.

Maintenance and repair

Strict adherence to the maintenance and repair schedule is an essential safety factor.

Never carry out maintenance and repair work with the engine running unless expressly instructed to do so.

Lock-out/tag-out the engine to preclude undesired starting. Disconnect the battery when electrical starters are fitted. Close the main valve on the compressed-air system and vent the compressed-air line when air starters are fitted. Post the "Do Not Start" sign in the operating room or affix it to the controlling device! Persons not involved must keep clear.

Never attempt to rectify faults or carry out repairs if you do not have the necessary experience or special tools required. Have maintenance and repair work carried out by qualified and authorized personnel only.

Use only proper, calibrated tools.

Do not work on engines or components which are only held by lifting equipment or crane. Always support by suitable means which conform with the applicable regulations before commencing maintenance or repair work.

Before barring the engine, make sure that nobody is standing in the danger zone. After completing work on the engine, check that all protective devices/safety guards have been installed and that all tools and loose parts have been removed from the engine.

Fluids emerging under high pressure can penetrate clothing and skin and may cause serious injury. Before starting work, relieve pressure in systems and compressed-air lines which are to be opened.

Never put lines to any use other than that for which they are intended. Never use lines for climbing.

Never bend a fuel line and do not install bent lines. Keep fuel injection lines and connections clean.

Always seal connections with caps or covers if a line is removed or opened.

Take care not to damage fuel lines during maintenance and repair work. To tighten the connections when installing the lines, use the correct tightening torque and ensure that all retainers and dampers are installed correctly.

Ensure that all fuel injection lines and pressurized oil lines have sufficient distance to other components to avoid contact with them. Do not place fuel or oil lines near hot components, except when necessary for design reasons during installation.

Elastomers (e.g. "Viton" sealing rings) are stable under normal operating conditions. The material decomposes when exposed to fire or temperatures exceeding 300 °C. Hydrogen fluoride vapors are released in this case. The resulting acid leads to serious burning if it contacts the skin. Do not touch elastomeric seals if they have carbonized or resinous appearance. Wear protective gloves!

Take care with hot fluids in lines, pipes and chambers ⇒ Risk of burning!

Note cooling period for components which are heated for installation or removal ⇒ Risk of burning!

Never touch hot parts of the compressor and exhaust system ⇒ Risk of burning!

Take special care when removing ventilation or plugs from engine. In order to avoid discharge of highly pressurized liquids, hold a cloth over the screw or plug. It is even more dangerous if the engine has recently been shut down, as the liquids can still be hot.

Take special care when draining hot fluids. ⇒ Risk of burning!

When draining, collect fluids in a suitable container, mop up any spilt fluids or wipe or soak them with a suitable binding agent.

When changing the engine oil or working on the fuel system, ensure that the engine room is adequately ventilated.

When working high on the engine, always use suitable ladders and work platforms. Make sure components are placed on stable surfaces.

In order to prevent back injuries when lifting heavy components adults, depending on age and sex, should only lift weights between max. 10 kg and 30 kg, therefore:

- Use lifting gear or seek assistance.
- Ensure that all chains, hooks, slings, etc. are tested and authorized, are sufficiently strong and that hooks are correctly positioned. Lifting eyes must not be unevenly loaded.

Observe special cleanliness when conducting maintenance and repair work on the engine plant. After completion of maintenance and repair work, make sure that no loose objects are in/on the engine plant.

Welding work

Never carry out welding work on the engine or engine-mounted units. Cover the engine when welding in its vicinity!

Never use the engine as a ground connection. This prevents the welding current passing through the engine resulting in burnt/scorched bearings, sliding surfaces and tooth flanks which may lead to bearing seizure and/or other material damage.

Never route the welding lead over or near the wiring harnesses of MTU systems. The welding current may otherwise induce an interference voltage in the wiring harnesses which could conceivably damage the electrical system.

The welding unit ground connection must not be more than 60 cm from the weld point.

If components (e.g. exhaust manifold) are to be welded, they must be removed from the engine.

It is not necessary to remove the connector and the connections when carrying out welding operation on MTU electronics if the master switch for power supply is switched from "ON" to "OFF" and the wire is disconnected from the negative and positive poles on the battery.

Hydraulic installation and removal

Only the hydraulic installation and removal equipment specified in the work schedule and in the assembly instructions must be used.

The max. permissible push-on pressure specified for the equipment must not be exceeded.

The H.P. lines for hydraulic installation and removal are tested with 3800 bar.

Do not attempt to bend or apply force to lines.

Before starting work, pay attention to the following:

- Vent the hydraulic installation/removal tool, the pumps and the lines at the relevant points for the system to be used (e.g. open vent plugs, pump until bubble-free air emerges, close vent plugs).
- For hydraulic installation, screw on the tool with the piston retracted.
- For hydraulic removal, screw on the tool with the piston extended.

For a hydraulic installation/removal tool with central expansion pressure supply, screw spindle into shaft end until correct sealing is achieved.

During hydraulic installation and removal, ensure that nobody is standing in the immediate vicinity of the component to be installed/removed. As long as the system is under pressure, there is the risk that the component to be installed/removed may be suddenly released from the pressure connection.

Before use, the tools must be checked at regular intervals (crack test).

Working on electrical/electronic assemblies

Always obtain the permission of the person in charge before commencing maintenance and repair work or switching off any part of the electronic system required to do so.

De-energize the appropriate areas prior to working on assemblies. Any measures requiring a power supply are expressly defined as such at the appropriate place in the manual.

Gases released from the battery are explosive. Avoid sparks and naked flames. Do not allow battery acids to come in contact with skin or clothing. Wear protective goggles. Do not place tools on the battery. Before connecting the cable to the battery, check battery polarity. Battery pole reversal may lead to injury through the sudden discharge of acid or bursting of the battery body.

Do not damage wiring during removal work and when reinstalling wiring and ensure that during operation it is not damaged by contact with sharp objects, by rubbing against other components or by a hot surface.

Do not secure wiring to fluid-carrying lines.

On completion of the maintenance and repair work, any cables which have become loose must be correctly connected and secured.

On completion of all repair work, the component and system must be subjected to a function check. Separate testing of the repaired component without system integration is insufficient.

If wires are installed beside mechanical components and there is a risk of chafing, use cable clamps to properly support the wires.

For this purpose, no cable binders must be used as, during maintenance and / or repair work, the binders can be removed but not installed a second time.

Spare parts shall be properly stored prior to replacement, i.e. particularly protected against moisture. Defective electronic components and assemblies must be suitably packed when dispatched for repair, i.e. particularly protected against moisture and impact and wrapped in antistatic foil if necessary.

Working with laser equipment

When working with laser equipment, always wear special laser-protection goggles.

Laser equipment can generate extremely intensive, concentrated radiation by the effect of stimulated emission in the range of visible light or in the infrared or ultraviolet spectral range. The photochemical, thermal and optomechanical effects of the laser can cause damage. The main danger is irreparable damage to the eyes.

Laser equipment must be fitted with the protective devices necessary for safe operation according to type and application.

For conducting light-beam procedures and measurement work, only the following laser devices must be used:

- Laser devices of classes 1, 2 or 3A,
- Laser devices of class 3B, which have maximum output in the visible wavelength range (400 to 700 nm), a maximum output of 5 mW, and in which the beam axis and surface are designed to prevent any risk to the eyes.

Operation of electrical equipment

When operating electrical equipment, certain components of this equipment are live.

Noncompliance with the warning instructions given for this equipment may result in serious injury or damage to property.

1.6 Auxiliary materials, fire prevention and environmental protection

Fire prevention

Rectify any fuel or oil leaks immediately; even splashes of oil or fuel on hot components can cause fires - therefore always keep the engine in a clean condition. Do not leave cloths soaked with fluids and lubricants lying around on the engine. Do not store combustible materials near the engine.

Do not carry out welding work on pipes and components carrying oil or fuel. Before welding, clean with a noncombustible fluid.

When starting the engine with a foreign power source, connect the ground lead last and remove it first. To avoid sparks in the vicinity of the battery, connect the ground lead from the foreign power source to the ground lead of the engine or to the ground terminal of the starter.

Always keep suitable fire-fighting equipment (fire extinguishers) at hand and familiarize yourself with their use.

Noise

Noise can lead to an increased risk of accident if acoustic signals, warning shouts or sounds indicating danger are drowned.

At all workplaces with a sound pressure level over 85 dB (A), always wear ear protectors (protective wadding, plugs or capsules).

Environmental protection

Dispose of used fluids, lubricants, materials and filters in accordance with local regulations.

Manipulation of the injection control system can influence the engine performance and exhaust emissions. As a result, compliance with environmental regulations may no longer be guaranteed.

Only fuels of the specified quality required to achieve emission limits must be used.

In Germany, the VAWs (= regulations governing the use of materials that may affect water quality) is applicable, which means work must only be carried out by authorized specialist companies (MTU is such a company).

Auxiliary materials

Use only fluids and lubricants that have been tested and approved by MTU.

Fluids and lubricants must be kept in suitable, properly designated containers. When using fluids, lubricants and other chemical substances, follow the safety instructions applicable to the product. Take care when handling hot, chilled or caustic materials. When using inflammable materials, avoid sparks, flames and do not smoke.

Lead

- When working with lead or lead-containing pastes, avoid direct contact to the skin and do not inhale lead vapors.
- Adopt suitable measures to avoid the formation of lead dust!
- Switch on fume extraction system.
- After coming into contact with lead or lead-containing materials, wash hands!

Acids and alkaline solutions

- When working with acids and alkalis, wear protective goggles or face mask, gloves and protective clothing.
- Immediately remove clothing wetted by acids and alkalis!
- Rinse injuries with plenty of water!
- Rinse eyes immediately with eyedrops or clean tap water.

Paints

- When painting anywhere other than in spray booths equipped with extractors, ensure good ventilation. Make sure that adjacent work areas are not affected.
- No naked flames!
- No smoking.
- Observe fire prevention regulations!
- Wear masks providing protection against paint and solvent fumes.

Liquid nitrogen

- Store liquid nitrogen only in small quantities and always in regulation containers without fixed covers.
- Do not bring liquid nitrogen in contact with the body (eyes, hands), as this causes frostbite and loss of tissue.
- Wear protective clothing, including gloves, closed shoes and protective goggles!

- Ensure that the room is well ventilated. Nitrogen concentration exceeding 88% of breathing air leads to suffocation.
- Avoid all knocks and jars to the containers, fixtures or workpieces.

Compressed air

Compressed air is air compressed at excess pressure and is stored in vessels from which it can be extracted. The pressure at which the air is kept can be read off at pressure gauges which must be connected to the compressed air vessels and the compressed air lines.

When working with compressed air, safety precautions must be constantly observed:

- Pay special attention to the pressure level in the compressed air network and pressure vessel!
- Devices and equipment connected must either be designed for this pressure or, if the permitted pressure for the connected elements is lower than the pressure required, a pressure reducing valve and safety valve (set to permitted pressure) must form an intermediate connection. Hose coupling and connections must be securely attached!
- Always wear protective goggles when blowing off tools or chips!
- The snout of the air nozzle should be provided with a protective disc (e.g. rubber disc), which prevents air-borne particles being deflected and thereby prevents injury to eyes.
- First shut off compressed air lines before compressed air equipment is disconnected from the supply line or before equipment or tools are exchanged!
- Unauthorized use of compressed air, e.g. forcing flammable liquids (hazard class A1, A11 and B) out of containers, carries the risk of explosion!
- Forcing compressed air into thin-walled containers (e.g. containers made of tin, plastic and glass) for drying purposes or to check for leaks, results in a risk of shattering!
- Do not use compressed air to clean contaminated clothing whilst it is being worn.



Used oil

Used oil may contain health-threatening combustion residues.

Rub barrier cream into hands!

Wash hands after contact with used oil.

1.7 Standards for warning notices in the publication

 DANGER	In the event of immediate danger. Consequences: Death or serious injury. <ul style="list-style-type: none">• Preventive measures
 WARNING	In the event of possibly dangerous situations. Consequences: Death or serious injury. <ul style="list-style-type: none">• Preventive measures
 CAUTION	In the event of dangerous situations. Consequences: Slight injury or material damage. <ul style="list-style-type: none">• Preventive measures

Note: This Publication contains especially emphasized safety instructions in accordance with the American standard ANSI Z535, which begin with one of the above signal words according to the degree of danger:

Warning notices

1. Read and become acquainted with all cautions and symbols before operating or repairing this product.
2. Pass on all safety instructions to your operating, maintenance, repair and transport personnel!

2 Product Summary

2.1 Engine Overview

2.1.1 Engine layout

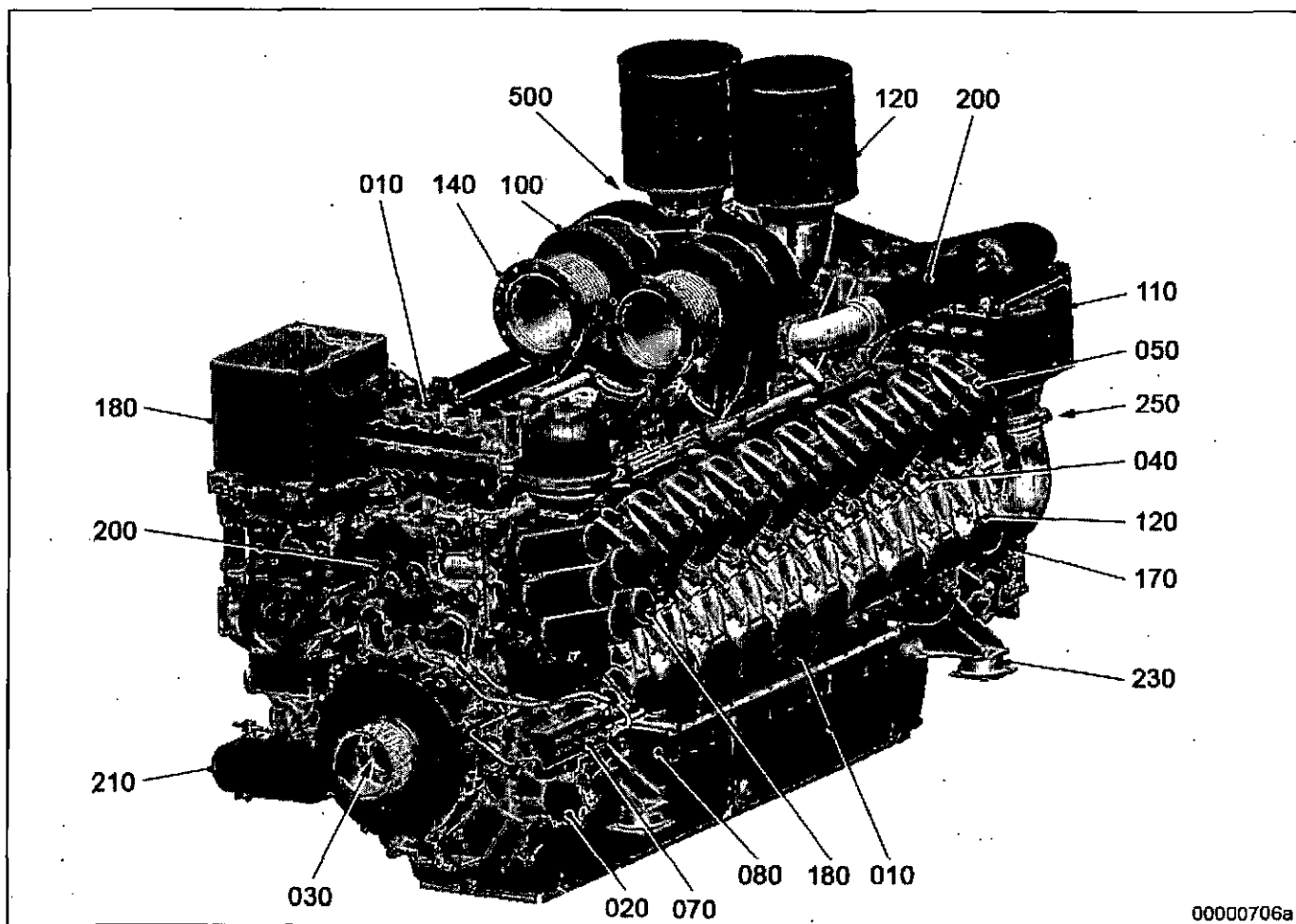

00000706a

- | | |
|---------------------------------|---|
| 010 Crankcase and attachments | 140 Exhaust system |
| 020 Gear train | 170 Starting equipment |
| 030 Crank drive | 180 Lube oil system / lube oil circuit |
| 040 Cylinder head | 200 Coolant system |
| 050 Valve gear | 210 Power supply |
| 070 Fuel system (high-pressure) | 230 Mounting / support |
| 080 Fuel system (low-pressure) | 250 PTO systems, driving end and free end (coupling) |
| 100 Exhaust turbocharger | 500 Monitoring and control system, general electric devices |
| 110 Intercooler | |
| 120 Air intake / air supply | |

Engine model designation

Key to the engine model designation 20V 4000 Gx3

20	Number of cylinders
V	Cylinder arrangement: V engine
4000	Series
G	Application
x	Application segment (2, 4, 6, 8)
3	Design index

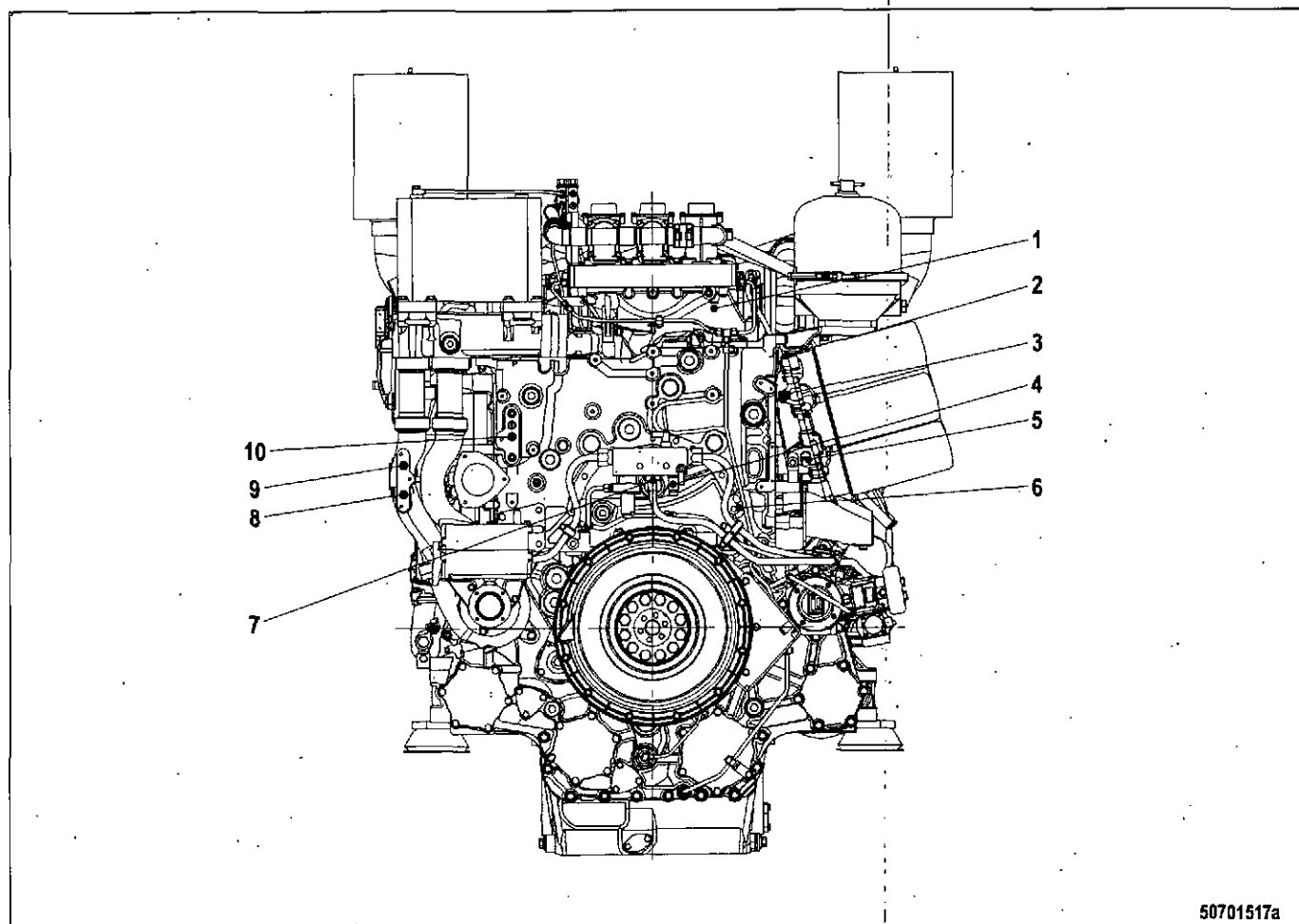

50701517a

- | | |
|------------------------------------|------------------------------|
| 1 B50 (P crankcase) | 6 B01 (N camshaft) |
| 2 B05.3 (P lube oil before filter) | 7 B48 (P fuel, rail) |
| 3 B05 (P lube oil after filter) | 8 B43 (P charge-air coolant) |
| 4 B33 (T fuel, rail) | 9 B26 (T charge-air coolant) |
| 5 B07 (T lube oil) | 10 B06 (T-coolant) |

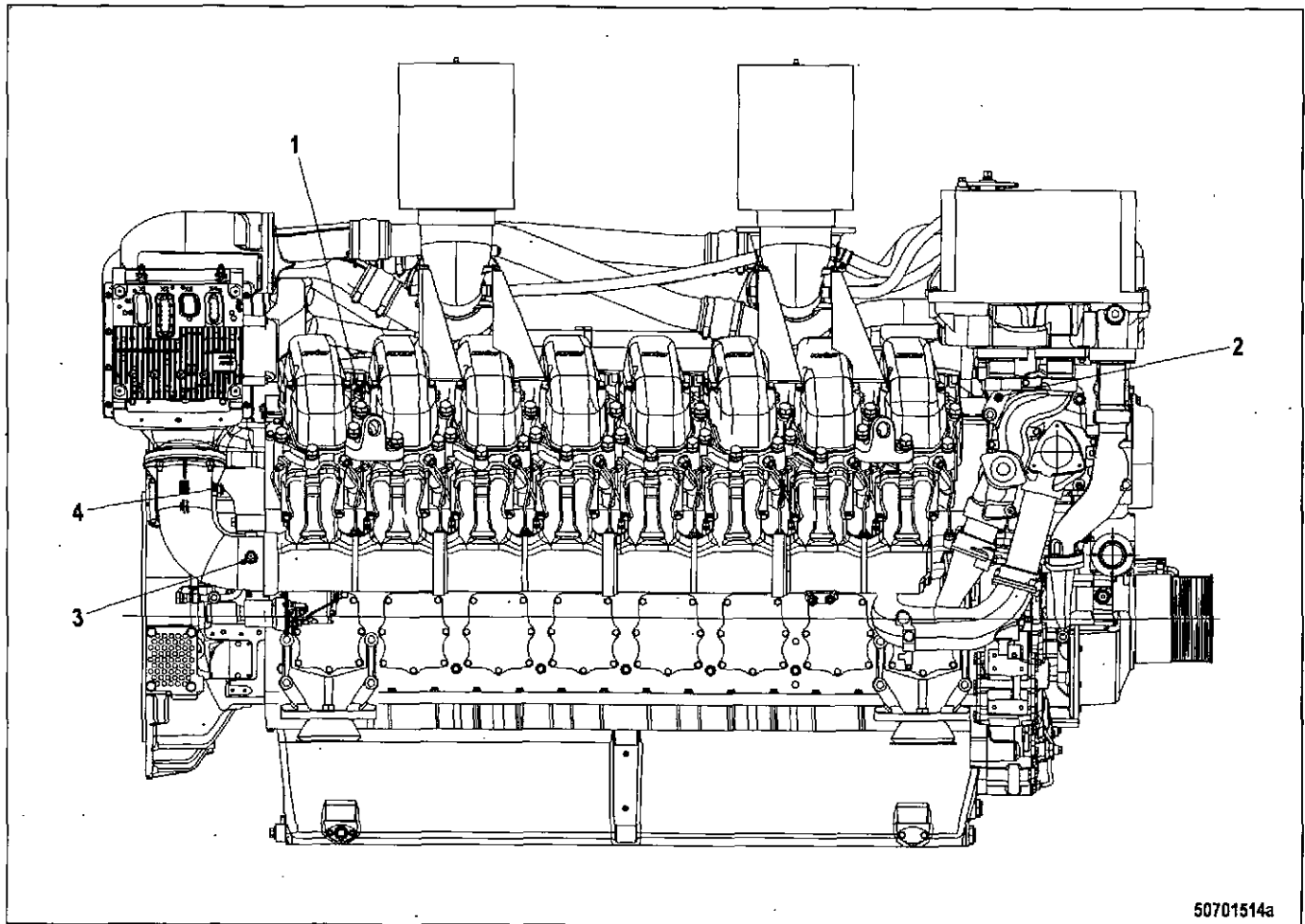

50701514a

- | | |
|---|----------------------|
| 1 Temperature sensors for single exhaust gas B4.11 to B4.18 (engine side B) | 2 B16 (P coolant) |
| | 3 B10 (P charge-air) |
| | 4 B09 (T charge-air) |

The injectors (Y39.11 to Y39.18, engine side B) are underneath the cylinder head covers of the cylinder. Replacement of injectors and activities required for this (→ Page 146)

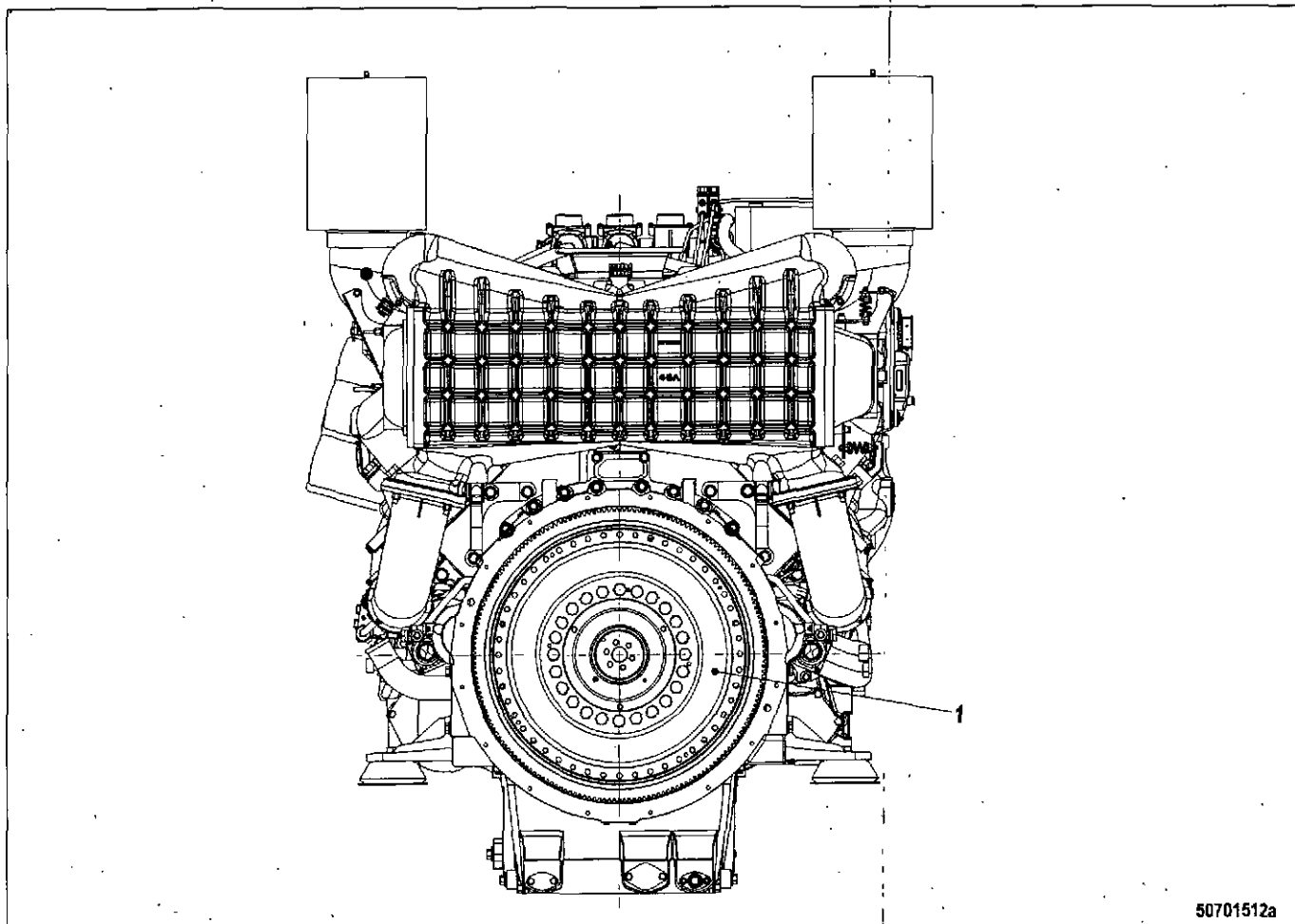

50701512a

1 B13 (N crankshaft)

2.2 Engine Side and Cylinder Designations

2.2.1 Engine side and cylinder designations

Engine sides are always designated as viewed from the driving end (KS).

The cylinders of the left engine side are designated "A" and those of the right side "B" (as per DIN ISO 1204). The cylinders of each bank are numbered consecutively, starting with No. 1 at the driving end.

The numbering of engine components is also from the driving end, starting with No. 1.

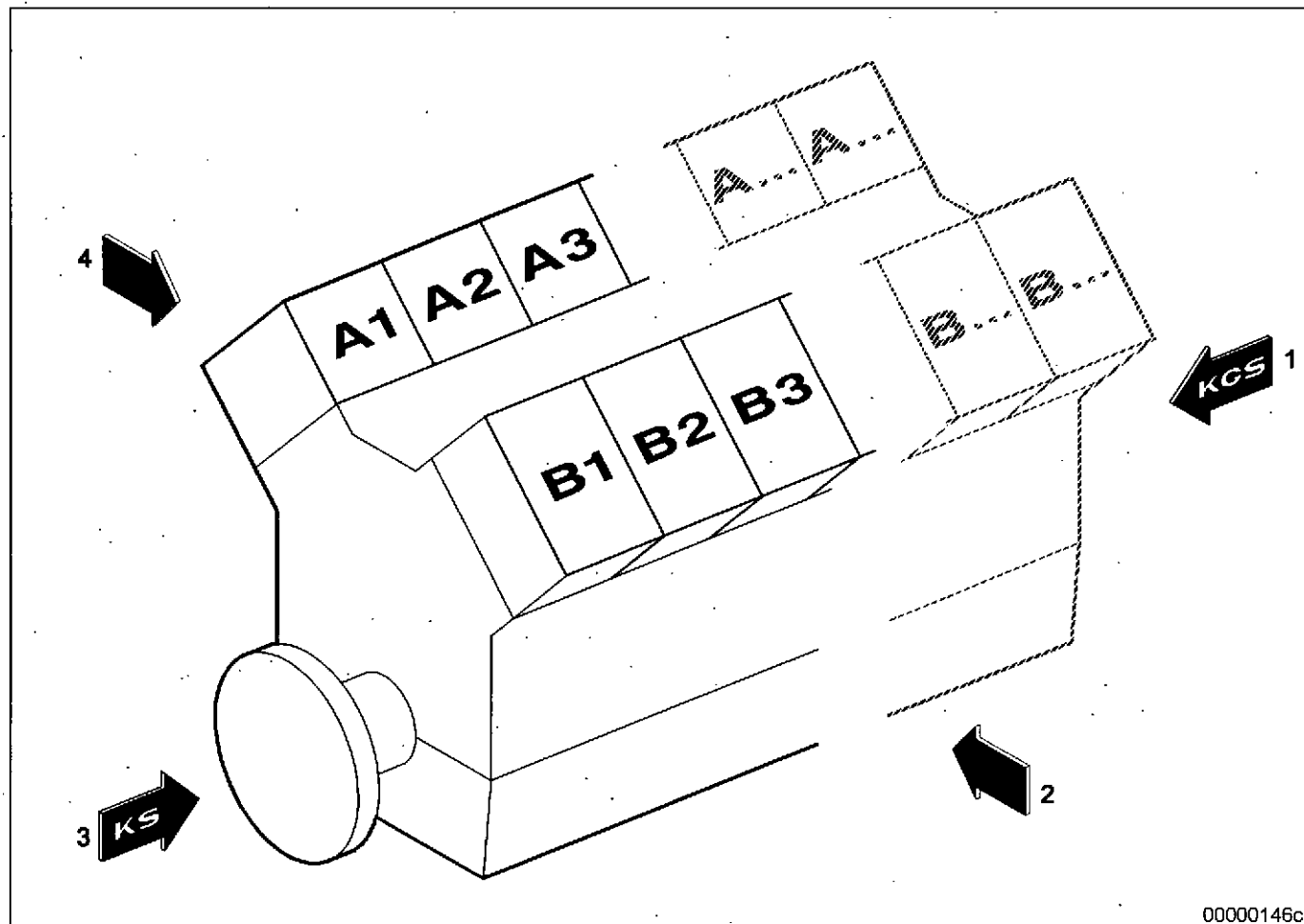

00000146c

1 KGS = Free end
2 Right side

3 KS = Driving end
4 Left side

2.3 Main Engine Dimensions

2.3.1 Main engine dimensions

Main engine dimensions

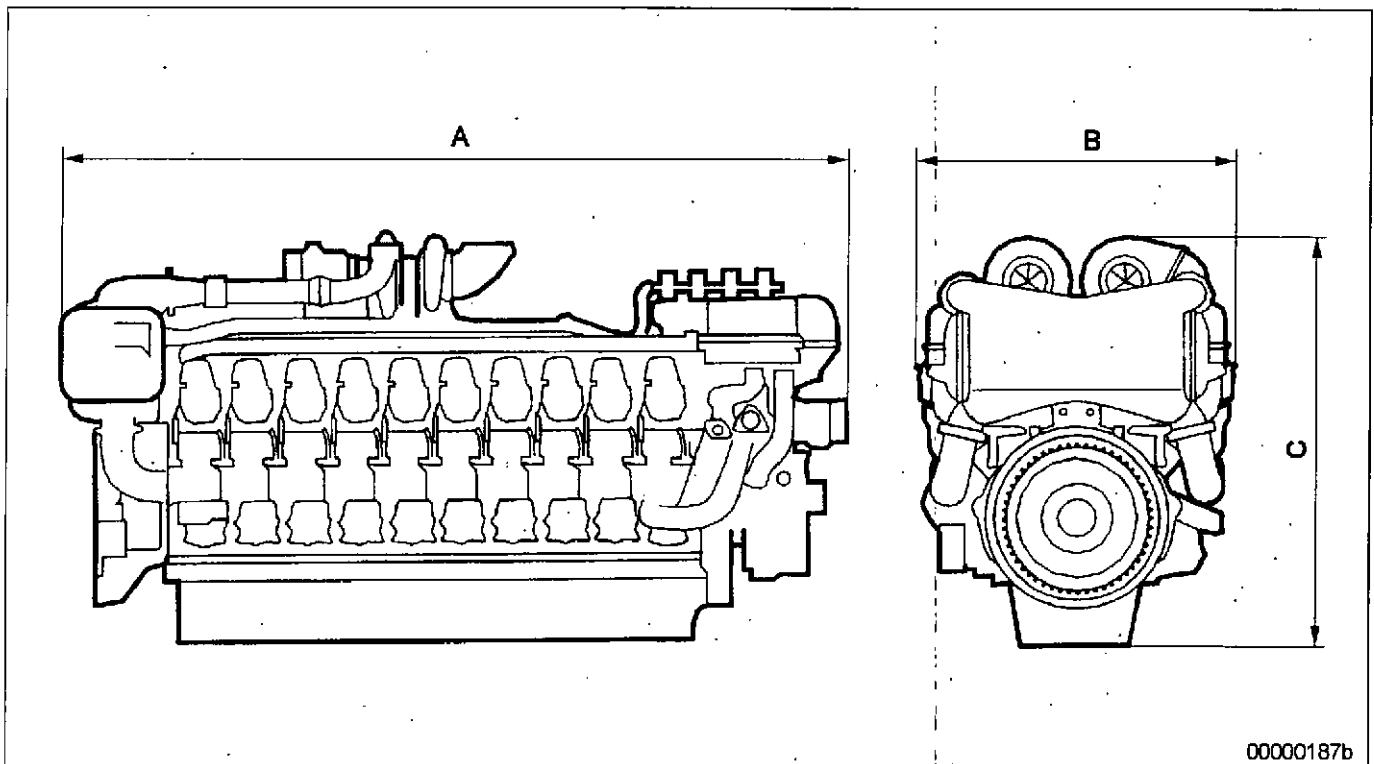

00000187b

Length (A)	approx. 3520 mm
Width (B)	approx. 1620 mm
Height (C)	approx. 2490 mm

2.4 Firing Sequence

2.4.1 Firing order

Firing order

8 V	A1-B4-A4-A2-B3-A3-B2-B1
12V	A1-B5-A5-B3-A3-B6-A6-B2-A2-B4-A4-B1
16 V	A1-A7-B4-B6-A4-B8-A2-A8-B3-B5-A3-A5-B2-A6-B1-B7
20V	A1-B5-A8-B7-A5-B2-A7-B10-A2-B3-A10-B6-A3-B4-A6-B9-A4-B1-A9-B8

2.5 Final Compression Pressure

2.5.1 Final compression pressure

Final compression pressure

Final compression pressure at 120 rpm	24 bar to 28 bar
---------------------------------------	------------------

2.6 Technical Data

2.6.1 20V 4000 Gx3 engine data: Standby operation 3D, optimized fuel consumption

Explanation:

DL Ref. value: Continuous power

BL Ref. value: Fuel stop power

A Design value

G Guaranteed value

R Guideline value

L Limit value, up to which the engine can be operated, without change (e.g. of power settings).

N Not yet defined value

- Not applicable

X Applicable

REFERENCE CONDITIONS

Engine model			20V 4000 G23	20V 4000 G43	20V 4000 G63	20V 4000 G63L	20V 4000 G83	20V 4000 G83L
Application group			3D	3D	3D	3D	3D	3D
Intake air temperature	°C		25	25	25	25	25	25
Charge-air coolant temperature	°C		55	55	55	55	55	55
Raw-water inlet temperature	°C		-	-	-	-	-	-
Barometric pressure	mbar		1000	1000	1000	1000	1000	1000
Site altitude above sea level	m		100	100	100	100	100	100

POWER-RELATED DATA (power ratings are net brake power as per ISO 3046)

Number of cylinders			20	20	20	20	20	20
Rated engine speed	A	rpm	1500	1800	1500	1500	1800	1800
Fuel stop power ISO 3046	A	kW	2420	2740	2670	2850	3010	3490

GENERAL CONDITIONS (for maximum power)

Number of cylinders			20	20	20	20	20	20
Intake air depression (new filter)	A	mbar	15	15	15	15	15	15
Intake air depression, max.	L	mbar	50	50	50	50	50	50
Exhaust pressure	A	mbar	30	30	30	30	30	30
Exhaust pressure, max.	L	mbar	85	85	85	85	85	85

MODEL RELATED DATA (basic design)

Number of cylinders			20	20	20	20	20	20
Engine with exhaust turbocharging (ETC) and charge air cooling (CAC)			X	X	X	X	X	X
Exhaust piping, non-cooled			X	X	X	X	X	X
Working method: four-cycle, diesel, single-acting			X	X	X	X	X	X
Combustion method: Direct fuel injection			X	X	X	X	X	X
Cooling system: conditioned water			X	X	X	X	X	X
Direction of rotation: c.c.w. (facing driving end)			X	X	X	X	X	X
Number of cylinders			20	20	20	20	20	20
Cylinder arrangement: V angle		Degrees	90	90	90	90	90	90
Bore		mm	170	170	170	170	170	170
Stroke		mm	210	210	210	210	210	210
Displacement, cylinder		liters	4.77	4.77	4.77	4.77	4.77	4.77
Displacement, total		liters	95.4	95.4	95.4	95.4	95.4	95.4

Number of cylinders			20	20	20	20	20	20
Compression ratio			16.5	16.5	16.5	16.5	16.5	16.5
Cylinder heads: single-cylinder			X	X	X	X	X	X
Cylinder liners: Wet, replaceable			X	X	X	X	X	X
Inlet valves per cylinder			2	2	2	2	2	2
Exhaust valves per cylinder			2	2	2	2	2	2
Standard flywheel housing flange (engine main PTO)		SAE	00	00	00	00	00	00
Flywheel interface		DISC	21	21	21	21	21	21

COMBUSTION AIR / EXHAUST GAS

Number of cylinders			20	20	20	20	20	20
Charge air pressure before cylinder, BL	R	bar abs	2.5	3.1	2.7	2.9	3.3	3.6

COOLANT SYSTEM (HT circuit)

Number of cylinders			20	20	20	20	20	20
Coolant temperature (at engine connection: outlet to cooling equipment)	A	°C	100	100	100	100	100	100
Coolant temperature after engine, alarm	R	°C	102	102	102	102	102	102
Coolant temperature after engine, shutdown	L	°C	104	104	104	104	104	104
Coolant antifreeze content, max.	L	%	50	50	50	50	50	50
Pressure loss in off-engine cooling system, max.	L	bar	0.7	0.7	0.7	0.7	0.7	0.7

COOLANT SYSTEM (LT circuit)

Number of cylinders			20	20	20	20	20	20
Coolant temperature before intercooler (at engine inlet from cooling equipment)	A	°C	45	45	45	45	45	45
Coolant antifreeze content, max.	L	%	50	50	50	50	50	50
Pressure loss in off-engine cooling system, max.	L	bar	0.7	0.7	0.7	0.7	0.7	0.7

LUBE-OIL SYSTEM

Number of cylinders			20	20	20	20	20	20
Lube-oil operating temperature before engine, from	R	°C	88	88	88	88	88	88
Lube-oil operating temperature before engine, to	R	°C	98	98	98	98	98	98
Lube-oil temperature before engine, alarm	R	°C	99	99	99	99	99	99
Lube-oil temperature before engine, shutdown	L	°C	101	101	101	101	101	101
Lube-oil operating pressure before engine, from	R	bar	4.5	5.0	4.3	4.3	4.9	4.8
Lube-oil operating pressure before engine, to	R	bar	7.3	7.8	7.1	7.1	7.7	7.6
Lube-oil pressure before engine, alarm	R	bar	--	--	--	--	--	--
Lube-oil pressure before engine, shutdown	L	bar	--	--	--	--	--	--

FUEL SYSTEM

Number of cylinders			20	20	20	20	20	20
Fuel pressure at engine inlet connection, min. (during engine starting)	L	bar	-0.1	-0.1	-0.1	-0.1	-0.1	-0.1
Fuel pressure at engine inlet connection, max. (during engine starting)	L	bar	1.5	1.5	1.5	1.5	1.5	1.5

GENERAL OPERATING DATA

Number of cylinders			20	20	20	20	20	20
Cold start capability: Air temperature (w/o start aid, w/o preheating) - (case A)	R	°C	10	10	10	10	10	10
Coolant preheating, preheating temperature (min.)	R	°C	32	32	32	32	32	32
Firing speed, from	R	rpm	80	80	80	80	80	80
Firing speed, to	R	rpm	120	120	120	120	120	120

ACOUSTICS

Number of cylinders			20	20	20	20	20	20
Exhaust noise, unsilenced, BL, (sound power level LW, ISO 6798)	R	dB(A)	131	134	130	131	136	136
Engine surface noise with attenuated intake noise (filter), BL (sound power level LW, ISO 6798)	R	dB(A)	126	129	127	128	130	133

2.6.2 20V 4000 Gx3 engine data: Standby operation 3D, optimized exhaust emissions (EPA stage 2)

Explanation:

DL Ref. value: Continuous power

BL Ref. value: Fuel stop power

A Design value

G Guaranteed value

R Guideline value

L Limit value, up to which the engine can be operated, without change (e.g. of power settings).

N Not yet defined value

- Not applicable

X Applicable

REFERENCE CONDITIONS

Engine model			20V 4000 G43	20V 4000 G83	20V 4000 G83L
Application group			3D	3D	3D
Intake air temperature		°C	25	25	25
Charge-air coolant temperature		°C	45	45	45
Raw-water inlet temperature		°C	-	-	-
Barometric pressure		mbar	1000	1000	1000
Site altitude above sea level		m	100	100	100

POWER-RELATED DATA (power ratings are net brake power as per ISO 3046)

Number of cylinders			20	20	20
Rated engine speed	A	rpm	1800	1800	1800
Fuel stop power ISO 3046	A	kW	2740	3010	3490

GENERAL CONDITIONS (for maximum power)

Number of cylinders			20	20	20
Intake air depression (new filter)	A	mbar	15	15	15
Intake air depression, max.	L	mbar	50	50	50
Exhaust pressure	A	mbar	30	30	30
Exhaust pressure, max.	L	mbar	85	85	85

GENERAL OPERATING DATA

Number of cylinders			20	20	20
Cold start capability: Air temperature (w/o start aid, w/o preheating) - (case A)	R	°C	10	10	10
Coolant preheating, preheating temperature (min.)	R	°C	32	32	32
Firing speed, from	R	rpm	80	80	80
Firing speed, to	R	rpm	120	120	120

CAPACITIES

Number of cylinders			20	20	20
Engine coolant capacity, engine side (without cooling equipment)	R	liters	205*	205*	205*
Charge-air coolant, engine side	R	liters	55*	55*	55*
Total engine oil capacity at initial filling (standard oil system) (Option: max. operating inclinations)	R	liters	390*	390*	390*
Oil change quantity, max. (standard oil system) (Option: max. operating inclinations)	R	liters			
Oil pan capacity at dipstick mark "min." (standard oil system) (Option: max. operating inclinations)	L	liters	245*	245*	245*
Oil pan capacity at dipstick mark "max." (standard oil system) (Option: max. operating inclinations)	L	liters	340*	340*	340*

WEIGHTS / MAIN DIMENSIONS

Number of cylinders			20	20	20
Engine weight, dry (basic engine configuration acc. to scope of supply specification)	R	kg	9640	9640	9640

ACOUSTICS

Number of cylinders			20	20	20
Exhaust noise, unsilenced, BL, (sound power level LW, ISO 6798)	R	dB(A)	136	136	127
Engine surface noise with attenuated intake noise (filter), BL (sound power level LW, ISO 6798)	R	dB(A)	130	132	134

2.6.3 20V 4000 Gx3 engine data: Continuous operation, variable 3B, optimized fuel consumption

Explanation:

DL Ref. value: Continuous power

BL Ref. value: Fuel stop power

A Design value

G Guaranteed value

R Guideline value

L Limit value, up to which the engine can be operated, without change (e.g. of power settings).

N Not yet defined value

- Not applicable

X Applicable

REFERENCE CONDITIONS

Engine model			20V 4000 G23	20V 4000 G43	20V 4000 G63	20V 4000 G63L	20V 4000 G83	20V 4000 G83L
Application group			3B	3B	3B	3B	3B	3B
Intake air temperature		°C	25	25	25	25	25	25
Charge-air coolant temperature		°C	55	55	55	55	55	55
Raw-water inlet temperature		°C	-	-	-	-	-	-
Barometric pressure		mbar	1000	1000	1000	1000	1000	1000
Site altitude above sea level		m	100	100	100	100	100	100

POWER-RELATED DATA (power ratings are net brake power as per ISO 3046)

Number of cylinders			20	20	20	20	20	20
Rated engine speed	A	rpm	1500	1800	1500	1500	1800	1800
Continuous power ISO 3046 (10% overload capability) (design power DIN 6280, ISO 8528)	A	kW	2200	2490	2420	2590	2740	3010

Number of cylinders			20	20	20	20	20	20
Cylinder heads: single-cylinder			X	X	X	X	X	X
Cylinder liners: Wet, replaceable			X	X	X	X	X	X
Inlet valves per cylinder			2	2	2	2	2	2
Exhaust valves per cylinder			2	2	2	2	2	2
Standard flywheel housing flange (engine main PTO)		SAE	00	00	00	00	00	00
Flywheel interface		DISC	21	21	21	21	21	21

COMBUSTION AIR / EXHAUST GAS

Number of cylinders			20	20	20	20	20	20
Charge air pressure before cylinder - DL	R	bar abs	2.3	2.8	2.5	2.6	3.1	3.3

COOLANT SYSTEM (HT circuit)

Number of cylinders			20	20	20	20	20	20
Coolant temperature (at engine connection: outlet to cooling equipment)	A	°C	100	100	100	100	100	100
Coolant temperature after engine, alarm	R	°C	102	102	102	102	102	102
Coolant temperature after engine, shutdown	L	°C	104	104	104	104	104	104
Coolant antifreeze content, max.	L	%	50	50	50	50	50	50
Pressure loss in off-engine cooling system, max.	L	bar	0.7	0.7	0.7	0.7	0.7	0.7

COOLANT SYSTEM (LT circuit)

Number of cylinders			20	20	20	20	20	20
Coolant temperature before intercooler (at engine inlet from cooling equipment)	A	°C	45	45	45	45	45	45
Coolant antifreeze content, max.	L	%	50	50	50	50	50	50
Pressure loss in off-engine cooling system, max.	L	bar	0.7	0.7	0.7	0.7	0.7	0.7

LUBE-OIL SYSTEM

Number of cylinders			20	20	20	20	20	20
Lube-oil operating temperature before engine, from	R	°C	88	88	88	88	88	88
Lube-oil operating temperature before engine, to	R	°C	98	98	98	98	98	98
Lube-oil temperature before engine, alarm	R	°C	99	99	99	99	99	99
Lube-oil temperature before engine, shutdown	L	°C	101	101	101	101	101	101
Lube-oil operating pressure before engine, from	R	bar	4.6	5.2	4.5	4.4	5.0	4.9
Lube-oil operating pressure before engine, to	R	bar	7.4	8.0	7.3	7.2	7.8	7.7
Lube oil pressure before engine, alarm	R	bar	--	--	--	--	--	--
Lube oil pressure before engine, shutdown	L	bar	--	--	--	--	--	--

FUEL SYSTEM

Number of cylinders			20	20	20	20	20	20
Fuel pressure at engine inlet connection, min. (during engine starting)	L	bar	-0.1	-0.1	-0.1	-0.1	-0.1	-0.1
Fuel pressure at engine inlet connection, max. (during engine starting)	L	bar	1.5	1.5	1.5	1.5	1.5	1.5

GENERAL OPERATING DATA

Number of cylinders			20	20	20	20	20	20
Cold start capability: Air temperature (w/o start aid, w/o preheating) - (case A)	R	°C	10	10	10	10	10	10
Coolant preheating, preheating temperature (min.)	R	°C	32	32	32	32	32	32
Firing speed, from	R	rpm	80	80	80	80	80	80
Firing speed, to	R	rpm	120	120	120	120	120	120

ACOUSTICS

Number of cylinders			20	20	20	20	20	20
Exhaust noise, unsilenced - DL (sound power level LW, ISO 6798)	R	dB(A)	130	133	131	132	134	136
Engine surface noise with attenuated intake noise (filter), DL (sound power level LW, ISO 6798)	R	dB(A)	125	128	126	126	129	130

2.6.4 20V 4000 Gx3 engine data: Continuous operation variable 3B, optimized exhaust emissions (EPA2)

Explanation:

DL Ref. value: Continuous power

BL Ref. value: Fuel stop power

A Design value

G Guaranteed value

R Guideline value

L Limit value, up to which the engine can be operated, without change (e.g. of power settings).

N Not yet defined value

- Not applicable

X Applicable

REFERENCE CONDITIONS

Engine model			20V 4000 G43	20V 4000 G83	20V 4000 G83L
Application group			3B	3B	3B
Intake air temperature		°C	25	25	25
Charge-air coolant temperature		°C	45	45	45
Raw-water inlet temperature		°C	-	-	-
Barometric pressure		mbar	1000	1000	1000
Site altitude above sea level		m	100	100	100

POWER-RELATED DATA (power ratings are net brake power as per ISO 3046)

Number of cylinders			20	20	20
Rated engine speed	A	rpm	1800	1800	1800
Continuous power ISO 3046 (10% overload capability) (design power DIN 6280, ISO 8528)	A	kW	2490	2740	3010

GENERAL CONDITIONS (for maximum power)

Number of cylinders			20	20	20
Intake air depression (new filter)	A	mbar	15	15	15
Intake air depression, max.	L	mbar	50	50	50
Exhaust pressure	A	mbar	30	30	30
Exhaust pressure, max.	L	mbar	85	85	85

MODEL RELATED DATA (basic design)

Number of cylinders			20	20	20
Engine with exhaust turbocharging (ETC) and charge air cooling (CAC)			X	X	X
Exhaust piping, non-cooled			X	X	X
Working method: four-cycle, diesel, single-acting			X	X	X
Combustion method: Direct fuel injection			X	X	X
Cooling system: conditioned water			X	X	X
Direction of rotation: c.c.w. (facing driving end)			X	X	X
Number of cylinders			20	20	20
Cylinder arrangement: V angle		degrees	90	90	90
Bore		mm	170	170	170
Stroke		mm	210	210	210
Displacement per cylinder		liter	4.77	4.77	4.77
Total displacement		liter	95.4	95.4	95.4
Compression ratio			16.5	16.5	16.5
Cylinder heads: single-cylinder			X	X	X
Cylinder liners: Wet, replaceable			X	X	X
Inlet valves per cylinder			2	2	2
Exhaust valves per cylinder			2	2	2
Standard flywheel housing flange (engine main PTO)		SAE	00	00	00
Flywheel interface		DISC	21	21	21

COMBUSTION AIR / EXHAUST GAS

Number of cylinders			20	20	20
Charge air pressure before cylinder - DL	R	bar abs	2.8	3.1	3.3

COOLANT SYSTEM (HT circuit)

Number of cylinders			20	20	20
Coolant temperature (at engine connection: outlet to cooling equipment)	A	°C	100	100	100
Coolant temperature after engine, alarm	R	°C	102	102	102
Coolant temperature after engine, shutdown	L	°C	104	104	104
Coolant antifreeze content, max.	L	%	50	50	50
Pressure loss in off-engine cooling system, max.	L	bar	0.7	0.7	0.7

COOLANT SYSTEM (LT circuit)

Number of cylinders			20	20	20
Coolant temperature before intercooler (at engine inlet from cooling equipment)	A	°C	45	45	45
Coolant antifreeze content, max.	L	%	50	50	50
Pressure loss in off-engine cooling system, max.	L	bar	0.7	0.7	0.7

LUBE-OIL SYSTEM

Number of cylinders			20	20	20
Lube-oil operating temperature before engine, from	R	°C	88	88	88
Lube-oil operating temperature before engine, to	R	°C	98	98	98
Lube-oil temperature before engine, alarm	R	°C	99	99	99
Lube-oil temperature before engine, shutdown	L	°C	101	101	101
Lube-oil operating pressure before engine, from	R	bar	5.0	5.0	4.9
Lube-oil operating pressure before engine, to	R	bar	7.8	7.8	7.7
Lube oil pressure before engine, alarm	R	bar	--	--	--
Lube oil pressure before engine, shutdown	L	bar	--	--	--

FUEL SYSTEM

Number of cylinders			20	20	20
Fuel pressure at engine inlet connection, min. (during engine starting)	L	bar	-0.1	-0.1	-0.1
Fuel pressure at engine inlet connection, max. (during engine starting)	L	bar	1.5	1.5	1.5

GENERAL OPERATING DATA

Number of cylinders			20	20	20
Cold start capability: Air temperature (w/o start aid, w/o preheating) - (case A)	R	°C	10	10	10
Coolant preheating, preheating temperature (min.)	R	°C	32	32	32
Firing speed, from	R	rpm	80	80	80
Firing speed, to	R	rpm	120	120	120

CAPACITIES

Number of cylinders			20	20	20
Engine coolant capacity, engine side (without cooling equipment)	R	liter	205*	205*	205*
Charge-air coolant, engine side	R	liter	55*	55*	55*
Total engine oil capacity at initial filling (standard oil system) (Option: max. operating inclinations)	R	liter	390*	390*	390*
Oil change quantity, max. (standard oil system) (Option: max. operating inclinations)	R	liter			
Oil pan capacity at dipstick mark "min." (standard oil system) (Option: max. operating inclinations)	L	liter	245*	245*	245*
Oil pan capacity at dipstick mark "max." (standard oil system) (Option: max. operating inclinations)	L	liter	340*	340*	340*

WEIGHTS / MAIN DIMENSIONS

Number of cylinders			20	20	20
Engine weight, dry (basic engine configuration acc. to scope of supply specification)	R	kg	9640	9640	9640

ACOUSTICS

Number of cylinders			20	20	20
Exhaust noise, unsilenced - DL (sound power level LW, ISO 6798)	R	dB(A)	134	136	136
Engine surface noise with attenuated intake noise (filter), DL (sound power level LW, ISO 6798)	R	dB(A)	129	130	132

2.6.5 20V 4000 Gx3 engine data: Continuous operation, variable 3B, optimized exhaust emissions (TA-Luft)

Explanation:

DL Ref. value: Continuous power

BL Ref. value: Fuel stop power

A Design value

G Guaranteed value

R Guideline value

L Limit value, up to which the engine can be operated, without change (e.g. of power settings).

N Not yet defined value

- Not applicable

X Applicable

REFERENCE CONDITIONS

Engine model			20V 4000 G23	20V 4000 G63	20V 4000 G63L
Application group			3B	3B	3B
Intake air temperature		°C	25	25	25
Charge-air coolant temperature		°C	55	55	55
Raw-water inlet temperature		°C	-	-	-
Barometric pressure		mbar	1000	1000	1000
Site altitude above sea level		m	100	100	100

POWER-RELATED DATA (power ratings are net brake power as per ISO 3046)

Number of cylinders			20	20	20
Rated engine speed	A	rpm	1500	1500	1500
Continuous power ISO 3046 (10% overload capability) (design power DIN 6280, ISO 8528)	A	kW	2200	2420	2590

GENERAL CONDITIONS (for maximum power)

Number of cylinders			20	20	20
Intake air depression (new filter)	A	mbar	15	15	15
Intake air depression, max.	L	mbar	50	50	50
Exhaust pressure	A	mbar	30	30	30
Exhaust pressure, max.	L	mbar	85	85	85

MODEL RELATED DATA (basic design)

Number of cylinders			20	20	20
Engine with exhaust turbocharging (ETC) and charge air cooling (CAC)			X	X	X
Exhaust piping, non-cooled			X	X	X
Working method: four-cycle, diesel, single-acting			X	X	X
Combustion method: Direct fuel injection			X	X	X
Cooling system: conditioned water			X	X	X
Direction of rotation: c.c.w. (facing driving end)			X	X	X
Number of cylinders			20	20	20
Cylinder arrangement: V angle		degrees	90	90	90
Bore		mm	170	170	170
Stroke		mm	210	210	210
Displacement per cylinder		liter	4.77	4.77	4.77
Total displacement		liter	95.4	95.4	95.4
Compression ratio			16.5	16.5	16.5
Cylinder heads: single-cylinder			X	X	X
Cylinder liners: Wet, replaceable			X	X	X
Inlet valves per cylinder			2	2	2
Exhaust valves per cylinder			2	2	2
Standard flywheel housing flange (engine main PTO)		SAE	00	00	00
Flywheel interface		DISC	21	21	21

COMBUSTION AIR / EXHAUST GAS

Number of cylinders			20	20	20
Charge air pressure before cylinder - DL	R	bar abs	2.6	2.9	3.1

COOLANT SYSTEM (HT circuit)

Number of cylinders			20	20	20
Coolant temperature (at engine connection: outlet to cooling equipment)	A	°C	100	100	100
Coolant temperature after engine, alarm	R	°C	102	102	102
Coolant temperature after engine, shutdown	L	°C	104	104	104
Coolant antifreeze content, max.	L	%	50	50	50
Pressure loss in off-engine cooling system, max.	L	bar	0.7	0.7	0.7

COOLANT SYSTEM (LT circuit)

Number of cylinders			20	20	20
Coolant temperature before intercooler (at engine inlet from cooling equipment)	A	°C	55	55	55
Coolant antifreeze content, max.	L	%	50	50	50
Pressure loss in off-engine cooling system, max.	L	bar	0.7	0.7	0.7

LUBE-OIL SYSTEM

Number of cylinders			20	20	20
Lube-oil operating temperature before engine, from	R	°C	88	88	88
Lube-oil operating temperature before engine, to	R	°C	98	98	98
Lube-oil temperature before engine, alarm	R	°C	99	99	99
Lube-oil temperature before engine, shutdown	L	°C	101	101	101
Lube-oil operating pressure before engine, from	R	bar	4.6	4.5	4.5
Lube-oil operating pressure before engine, to	R	bar	7.4	7.3	7.3
Lube oil pressure before engine, alarm	R	bar	--	--	--
Lube oil pressure before engine, shutdown	L	bar	--	--	--

FUEL SYSTEM

Number of cylinders			20	20	20
Fuel pressure at engine inlet connection, min. (during engine starting)	L	bar	-0.1	-0.1	-0.1
Fuel pressure at engine inlet connection, max. (during engine starting)	L	bar	1.5	1.5	1.5

GENERAL OPERATING DATA

Number of cylinders			20	20	20
Cold start capability: Air temperature (w/o start aid, w/o preheating) - (case A)	R	°C	10	10	10
Coolant preheating, preheating temperature (min.)	R	°C	32	32	32
Firing speed, from	R	rpm	80	80	80
Firing speed, to	R	rpm	120	120	120

CAPACITIES

Number of cylinders			20	20	20
Engine coolant capacity, engine side (without cooling equipment)	R	liter	205*	205*	205*
Charge-air coolant, engine side	R	liter	55*	55*	55*
Total engine oil capacity at initial filling (standard oil system) (Option: max. operating inclinations)	R	liter	390*	390*	390*
Oil change quantity, max. (standard oil system) (Option: max. operating inclinations)	R	liter			
Oil pan capacity at dipstick mark "min." (standard oil system) (Option: max. operating inclinations)	L	liter	245*	245*	245*
Oil pan capacity at dipstick mark "max." (standard oil system) (Option: max. operating inclinations)	L	liter	340*	340*	340*

WEIGHTS / MAIN DIMENSIONS

Number of cylinders			20	20	20
Engine weight, dry (basic engine configuration acc. to scope of supply specification)	R	kg	9640	9640	9640

ACOUSTICS

Number of cylinders			20	20	20
Exhaust noise, unsilenced - DL (sound power level LW, ISO 6798)	R	dB(A)	130	131	132
Engine surface noise with attenuated intake noise (filter), DL (sound power level LW, ISO 6798)	R	dB(A)	126	128	129

3 Operation

3.1 Putting the engine into operation after extended out-of-service-periods (>3 months)

Preconditions

- Engine is stopped and starting disabled.
- MTU Fluids and Lubricants Specifications (A001061/..) are available.

Putting the engine into operation after extended out-of-service-periods (>3 months)

Item	Task
Engine	Depreserve (→MTU Fluids and Lubricants Specifications A001061/..).
Valve gear	Lubricate valve gear every ≥ 6 months (→ Page 140).
Lube oil system	Check engine oil level (→ Page 169).
Fuel prefilter	Prime (→ Page 160).
Fuel prefilter, pressure gauge	Align adjustable pointer with position of pressure indicator (→ Page 155).
Coolant circuit	If engine is out of service for more than one year, change engine coolant (→ Page 177); Change charge-air coolant (→ Page 185).
Coolant circuit	Check engine coolant level (→ Page 176); Check charge-air coolant level (→ Page 184).
Coolant circuit	Preheat coolant with preheating unit.
ECU	Check plug-in connections (→ Page 196).
Monitoring equipment	Carry out lamp test (see manufacturer's documentation).
Engine/generator control system	Switch ON; Select operating mode, e.g. MANUAL OPERATION, AUTOMATIC OPERATION.

3.2 Putting the engine into operation after scheduled out-of-service-period

Preconditions

- Engine is stopped and starting disabled.

Putting the engine into operation

Item	Task
Lube oil system	Check oil level (→ Page 169);
Cooling system	Check engine coolant level (→ Page 176); Check charge-air coolant level (→ Page 184).
Cooling system	Preheat coolant with preheating unit.
Fuel prefilter	Drain (→ Page 156).
Monitoring equipment	Carry out lamp test (see manufacturer's documentation).
Engine/generator control system	Switch ON; Select operating mode, e.g. MANUAL OPERATION, AUTOMATIC OPERATION.

3.3 Start engine in manual mode (testing mode)

Preconditions

- Generator (if provided) not connected to network.
- External start interlock is not activated.

 DANGER	Unguarded rotating and moving engine components. Risk of serious injury — danger to life! <ul style="list-style-type: none"> • Before barring or starting the engine, ensure that nobody is in the danger zone.
--	--

 WARNING	Engine noise above 85 dB (A). Risk of damage to hearing! <ul style="list-style-type: none"> • Wear ear protectors.
---	---

Preparation

Item	Task
Operating mode selector switch (if provided)	Change to manual mode.
Preheating pump (if provided)	Switch ON.

Starting the engine

Item	Task
Switchgear cabinet, control panel etc. (depending on manufacturer)	If coolant temperature is <ul style="list-style-type: none"> • > 40 °C (with preheating equipment), or • > 5 °C (without preheating equipment): Press start button. <ul style="list-style-type: none"> • Automatic starting sequence is performed; • Engine speed display instrument indicates increasing crankshaft speed; • After the starting sequence is completed, engine is running at rated speed.

Connect generator to network (if provided), run engine to reach operating temperature)

Item	Task
Switchgear cabinet, control panel etc. (depending on manufacturer)	Close the generator circuit breaker.
Engine	Apply full load only after engine has reached operating temperature (coolant temperature approx. 75 °C).

3.4 Bypassing the safety system (Override)



Safety functions and engine shutdown alarms will be disregarded.
Serious damage to plant!

- Initiate emergency start only in emergency situations.



Inadmissible operational condition.
Major material damage!

- Use override function only in hazardous situations to ensure full capability in case of engine malfunctions.

Preparation

Note: This function is only available when a pushbutton is provided.

Bypassing the safety system (Override)

Item	Task
Switching cabinet, control panel etc. (depending on manufacturer)	Activate pushbutton for Override input of the ECU. <ul style="list-style-type: none"> • Certain shutdown criteria and/or starting prerequisites are ignored.
Switchgear cabinet, control panel etc. (depending on manufacturer)	Actuate start button, for further starting sequence see Engine start (→ Page 55).
Control and display panels	During operation, check the displayed operational data (speed, temperature, pressures). Constantly monitor plant limit values.

3.5 Starting the engine in emergency situations (override mode)



Safety functions and engine shutdown alarms will be disregarded.

Serious damage to plant!

- Initiate emergency start only in emergency situations.

Preparation

Item	Task
Operating mode switch	Set to emergency mode.



Starting the engine in emergency situations

Item	Task
Control cabinet	Actuate switch/button for ECU override input.
Control cabinet	<ul style="list-style-type: none"> • Automatic starting procedure is performed; any safety functions and alarms leading to engine shutdown are disregarded; • Tachometer indicates increasing crankshaft speed; • Engine is running at rated speed when the starting sequence is completed.

Connecting the generator (if fitted) to mains

Item	Task
Control cabinet	If generator is not connected to mains: Close generator circuit breaker.
Engine	Operate engine at rated power.

3.6 Operational checks

 DANGER	<p>Unguarded rotating and moving engine components. Risk of serious injury – danger to life!</p> <ul style="list-style-type: none"> • Take special care when working on a running engine.
 WARNING	<p>Engine noise above 85 dB (A). Risk of damage to hearing!</p> <ul style="list-style-type: none"> • Wear ear protectors.

Operational checks

Item	Task
Control and display panels	Check displayed operational data (speed, temperature, pressures).
Engine under load, Engine at nominal speed	Check engine/system and lines for leak-tightness, perform maintenance work on lines showing leakage while motor is turned off (exhaust manifolds and turbocharger turbine housing may be glowing with heat. If maximum exhaust temperatures are within the limit, restricted engine operation is not required); Check for abnormal running noises and vibration.
Fuel prefilter	Check if suction-side pressure indicated at the fuel prefilter pressure gauge is within the limit (→ Page 155).
Exhaust system	Check exhaust color (→ Page 75).
Intercooler	Check drain for coolant discharge and obstruction (→ Page 162).
Air filters	Check signal ring position of service indicator (→ Page 166); Replace air filter (→ Page 163), if the signal ring is completely visible in the service indicator control window.
Engine coolant pump	Check relief bore (→ Page 182).
Charge-air coolant pump	Check relief bore (→ Page 190).
Compressed-air system (if applicable)	Check operating pressure on pressure gauge; Always fill compressed-air tank to max. pressure; Drain condensate from compressed-air tank, pressure drop must not exceed 1 bar.

3.7 Stop engine in manual mode (testing mode)

Preconditions

- Generator (if provided) not connected to network.
- Engine is running in manual mode.

 CAUTION	Stopping the engine when it is running at full load causes extreme stress to the engine. Risk of overheating, damage to components! <ul style="list-style-type: none"> • Before stopping the engine, operate it at idle speed until operating temperatures decrease and stable values are indicated.
---	---

Preparing the generator drive (only with generator breaker)

Item	Task
Engine	After opening the generator breaker (if provided), allow to cool down off-load for approx. 5 minutes.

Preparing the pump drive (diesel-mechanical/diesel-electric)

Item	Task
Engine	Allow to cool down for approx. 5 minutes at reduced engine speed. Observe natural resonance of engine (installation-dependent)!

Stopping the engine

Item	Task
Switchgear cabinet, control panel etc. (depending on manufacturer)	Press stop button. <ul style="list-style-type: none"> • Automatic stopping sequence is performed; • Engine is stopped.

After stopping the engine

Item	Task
Coolant pump	Allow to run on for sufficient time after stopping.

3.8 Emergency stop



CAUTION

An emergency stop causes extreme stress to the engine.

Risk of overheating, damage to components!

- Initiate emergency stop only in emergency situations!

Emergency stop from LOP

Item	Task
EMERGENCY STOP button	Press. <ul style="list-style-type: none"> • Engine is stopped by switching off power supply to ECU; • Signalization (e.g. by horn, flashing lamp) is released.

After emergency stop from LOP

Item	Task
Switching cabinet, control panel etc. (depending on manufacturer)	Press button for alarm acknowledgement. <ul style="list-style-type: none"> • Audible and visual signalization stops.

3.9 After stopping the engine – engine remains ready for operation

After stopping the engine

Item	Task
Engine/generator/pump controller	Select operating mode, e.g. MANUAL OPERATION, AUTOMATIC OPERATION.

3.10 After stopping the engine – putting the engine out of service

Preconditions

- MTU Fluids and Lubricants Specifications (A001061/..) is available.

After stopping the engine

Item	Task
Cooling system	Drain engine coolant (→ Page 178); Drain charge-air coolant (→ Page 186) if: <ul style="list-style-type: none"> • freezing temperatures are expected and the engine is to remain out of service for an extended period and coolant has no antifreeze additive; • the engine room is not heated; • the coolant is not maintained at a suitable temperature; • the antifreeze concentration is insufficient for the engine-room temperature; • antifreeze concentration is 50 % and engine-room temperature is below -40°C.
Engine/generator/pump controller	Switch OFF.
Air intake and exhaust system	If the engine is to remain out of service for more than 1 week, seal the engine's air and exhaust sides. If the engine is to remain out of service for more than 1 month, preserve engine (→MTU Fluids and Lubricants Specifications A001061/..).

3.11 Plant – Cleaning

Preconditions

- Engine is stopped and starting disabled.
- Operating voltage is not applied.

Special tools

Designation / Use	Part No.	Qty.
Steam jet cleaner		

Material

Designation / Use	Part No.	Qty.
Cleaner (Hakupur 312)	30390	1



Compressed air.

Risk of injury!

- Do not direct compressed-air jet at persons.
- Wear protective goggles / safety mask and ear protectors.



Water jet.

Risk of injury and scalding!

- Do not direct water jet at persons.
- Wear protective clothing, gloves, and goggles / safety mask.



Excessive reaction time of cleaning agents on components.

Damage to component!

- Observe manufacturer's instructions.
- Wear protective clothing, gloves, and goggles / safety mask.

Plant cleaning

1. Carry out plant cleaning only in areas where an appropriate oil separator is provided (environmental protection).
2. Prior to putting the cleaning unit into operation, read the Operating Instructions of the water/steam jet unit carefully and observe the safety precautions.
3. For external cleaning with high-pressure jet, use a flat-mouth nozzle only.
4. Carry out external cleaning as follows:
 - 4.1. Remove coarse dirt.
 - 4.2. Spray on cleaner sparingly and leave it for 1 to 5 minutes.
 - 4.3. Use the high-pressure jet to remove the loosened dirt.
 - 4.4. During external cleaning of the plant with water/steam-jet units, the pressure of the high-pressure jet (cleaning jet) must not exceed 50 bar. A minimum distance between spray nozzle and plant of 1 m must be observed. The temperature of the cleaning medium must not exceed 80°C.

Load profile

Power	90%	75%	50%	20%
Associated runtime	5%	40%	50%	5%

4.3 Activities

Qualification	Interval		Item	Activities	Task
	[h]	[a]			
QL1	-	0.083	Engine operation	Perform test run, min. duration until steady-state temperature reached, not below 1/3 load (monthly) (→ Page 133).	W0534
QL1	-	2	Engine oil filter	Replace engine oil filter every time oil is changed, latest when year limit is reached (→ Page 173).	W1008
QL1	Daily	-	Engine operation	Check engine oil level (→ Page 58). Check leak-tightness visually and inspect general condition of the engine (→ Page 58). Check intercooler drainage (if applicable) (→ Page 58). Check air filter maintenance indicator (→ Page 58). Check water pump relief bores (→ Page 58). Check for abnormal running noises, exhaust gas coloration and vibrations (→ Page 58). Drain water and contaminants from fuel prefilter (if applicable) (→ Page 58). Check fuel prefilter contamination indicator (if applicable) (→ Page 58).	W0500 W0501 W0502 W0503 W0505 W0506 W0507 W0508
QL1	500	2	Centrifugal oil filter	Centrifugal oil filter (if applicable): Check oil residue layer thickness, clean, replace filter sleeve (→ Page 174).	W1009
QL1	1000	-	Valve gear	Check valve clearance (→ Page 141).	W1002
QL1	1000	2	Fuel filter	Replace fuel filter or fuel filter element (→ Page 153).	W1001
QL1	1500	2	Belt drive	Check condition of drive belt, replace as necessary (→ Page 191); adjust tension (→ Page 192).	W1241
QL1	3000	3	Air filter	Replace air filter (→ Page 163).	W1005
QL1	5000	-	Fuel injectors	Replace fuel injectors (→ Page 146).	W1006
QL1	5000	4	Cylinder chambers	Endoscope cylinder chambers (→ Page 134).	W1011
QL1	10000	-	Crankcase breather	Crankcase breather: Replace filter or filter element.	W1046
QL3	10000	-	Component maintenance	Drain coolant and flush coolant circuits before commencing maintenance work. Clean air line (→Maintenance Manual). Clean intercooler and check leak-tightness (→Maintenance Manual). Replace HP fuel sensor (→Maintenance Manual). Check engine coolant thermostat and replace thermostat element (→Maintenance Manual). Check charge-air coolant thermostat and replace thermostat element (→Maintenance Manual). Check centrifugal oil filter for wear (if applicable) (→Maintenance Manual). Overhaul starter (→Maintenance Manual). Overhaul charge-air coolant pump (→Maintenance Manual). Replace sealing materials on all dismantled components.	W2000 W2002 W2003 W2004 W2006 W2007 W2009 W2010 W2070 W2062

4.4 Preface

MTU maintenance schedule concept

The maintenance system for MTU products is based on a preventive maintenance concept. Preventive maintenance facilitates advance operational planning and ensures a high degree of operational availability.

The maintenance schedule is based on the load profile/load factor specified below. The intervals at which maintenance work is to be performed and the scope of the inspection and maintenance activities described are based on experience of average use and serve only as a guide. Additional maintenance work and/or adaptation of maintenance intervals may prove necessary for special applications and technical requirements. Maintenance personnel charged with carrying out maintenance work must be appropriately qualified depending on the complexity of the task concerned. The various stages QL1 to QL4 correspond to the scope of training offered by MTU and the tools included in the kits:

QL1: Operational monitoring and maintenance work which may be performed without disassembling the engine when it is out of operation.

QL2: Component replacement (corrective only).

QL3: Maintenance work requiring partial disassembly of the engine.

QL4: Maintenance work requiring complete disassembly of the engine.

The maintenance schedule matrix normally finishes with extended component maintenance. Maintenance work then continues in accordance with the intervals stated.

The "Task" numbers stated in the action list identify the various maintenance activities. They serve as a reference for the scope of parts needed and also appear on the labels of the corresponding spare parts.

Notes on maintenance

Fluids and lubricants specifications, maintenance and replacement interval guidelines and the list of recommended fluids and lubricants are provided in the MTU Fluids and Lubricants Specifications A001061 and in the fluids and lubricants specifications of the component manufacturers. They are therefore not listed in the maintenance schedule (exception: deviations from the Fluids and Lubricants Specifications). Only use fluids and lubricants which meet MTU specifications or are approved by the component manufacturer concerned.

The user/customer is also obliged to perform the following additional maintenance work:

- Parts made of rubber or synthetic materials shall be protected from oil, wiped clean with a dry cloth only, and never cleaned with organic cleaning agents.
- Fuel prefilter:
Fuel quality greatly influences the maintenance intervals. Paper elements in fuel prefilters must be replaced every 2 years at the latest (task 9998).
- Battery:
Battery maintenance depends on their use and prevailing ambient conditions. Battery manufacturer's specifications shall apply.

Manufacturer's specifications shall apply to the maintenance of all components not listed in this maintenance schedule. Items listed in this maintenance schedule which do not apply to the engine variant concerned may be disregarded.

Downtimes

Preserve the engine as per MTU Fluids and Lubricants Specifications A001061 for downtimes exceeding 1 month in duration.

Application group

3D Temporary operation, blocked

Load profile

Power	80%	50%	20%
Associated runtime	25%	50%	25%

4.6 Activities

Qualification	Interval		Item	Activities	Task
	[h]	[a]			
QL1	-	0.083	Engine operation	Perform test run, min. duration until steady-state temperature reached, not below 1/3 load (monthly) (→ Page 133).	W0534
QL1	-	2	Engine oil filter	Replace engine oil filter every time oil is changed, latest when year limit is reached (→ Page 173).	W1008
QL1	Daily	-	Engine operation	<p>Check engine oil level (→ Page 58).</p> <p>Check leak-tightness visually and inspect general condition of the engine (→ Page 58).</p> <p>Check intercooler drainage (if applicable) (→ Page 58).</p> <p>Check air filter maintenance indicator (→ Page 58).</p> <p>Check water pump relief bores (→ Page 58).</p> <p>Check for abnormal running noises, exhaust gas coloration and vibrations (→ Page 58).</p> <p>Drain water and contaminants from fuel prefilter (if applicable) (→ Page 58).</p> <p>Check fuel prefilter contamination indicator (if applicable) (→ Page 58).</p>	<p>W0500</p> <p>W0501</p> <p>W0502</p> <p>W0503</p> <p>W0505</p> <p>W0506</p> <p>W0507</p> <p>W0508</p>
QL1	500	2	Centrifugal oil filter	Centrifugal oil filter (if applicable): Check oil residue layer thickness, clean, replace filter sleeve (→ Page 174).	W1009
QL1	1000	-	Valve gear	Check valve clearance (→ Page 141).	W1002
QL1	1000	2	Fuel filter	Replace fuel filter or fuel filter element (→ Page 153).	W1001
QL1	1000	2	Belt drive	Check condition of drive belt, replace as necessary (→ Page 191); adjust tension (→ Page 192).	W1241
QL1	3000	3	Air filter	Replace air filter (→ Page 163).	W1005
QL1	6000	-	Fuel injectors	Replace fuel injectors (→ Page 146).	W1006
QL1	6000	4	Cylinder chambers	Endoscope cylinder chambers (→ Page 134).	W1011
QL1	6000	-	Crankcase breather	Crankcase breather: Replace filter or filter element (→ Page 138).	W1046
QL3	6000	-	Exhaust turbocharger	Overhaul exhaust turbochargers (→Maintenance Manual).	W1038
QL3	6000	-	Component maintenance	<p>Drain coolant and flush coolant circuits before commencing maintenance work.</p> <p>Check rockers and valve bridge for wear. Inspect swing followers and camshaft surfaces with endoscope through pushrod bore (→Maintenance Manual).</p> <p>Clean air line (→Maintenance Manual).</p> <p>Clean intercooler and check leak-tightness (→Maintenance Manual).</p> <p>Replace HP fuel sensor (→Maintenance Manual).</p> <p>Check engine coolant thermostat and replace thermostat element (→Maintenance Manual).</p> <p>Check charge-air coolant thermostat and replace thermostat element (→Maintenance Manual).</p> <p>Check centrifugal oil filter for wear (if applicable) (→Maintenance Manual).</p>	<p>W2000</p> <p>W2001</p> <p>W2002</p> <p>W2003</p> <p>W2004</p> <p>W2006</p> <p>W2007</p> <p>W2009</p>

Engine fires unevenly

Component	Probable cause	Task
Fuel injection equipment	Injector defective	Replace (→ Page 146).
Engine wiring	Defective	Check (→ Page 194).
Fuel system	Not vented	Vent fuel system (→ Page 152).
Engine Governor	Defective	Contact Service.

Engine does not reach nominal speed

Component	Probable cause	Task
Fuel supply	Fuel prefilter clogged	Replace (→ Page 160).
	Easy-change fuel filter clogged	Replace (→ Page 153).
Air supply	Air filter clogged	Check signal ring position of service indicator (→ Page 166).
Fuel injection equipment	Injector defective	Replace (→ Page 146).
Engine wiring	Defective	Check (→ Page 194).
Engine	Overloaded	Contact Service.

Engine speed not steady

Component	Probable cause	Task
Fuel injection equipment	Injector defective	Replace (→ Page 146).
Speed sensor	Defective	Contact Service.
Fuel system	Not vented	Vent fuel system (→ Page 152).
Engine Governor	Defective	Contact Service.

Charge-air temperature too high

Component	Probable cause	Task
Engine coolant	Incorrect coolant concentration	Check (MTU test kit).
Intercooler	Contaminated	Contact Service.
Engine room	Air-intake temperature too high	Check fans and air supply / ventilation ducts.

5.2 Fault messages on the SAM display

The fault code numbers are generated by the engine governor and transmitted to the display below.

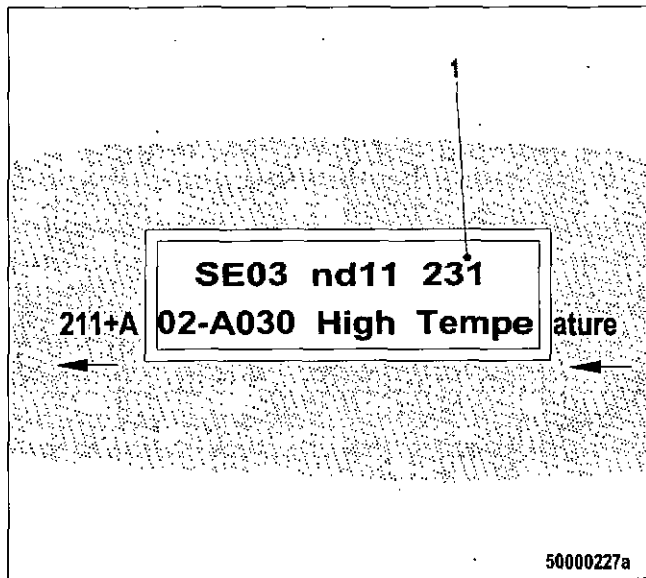

The fault code (1) comprises three digits.

Fault messages may also be caused by faulty sensors/actuators. Contact Service should troubleshoot as prescribed in the table below prove unsuccessful. The Service can check sensors/actuators and replace them if necessary.

The following fault codes may appear: (→ Page 79).

010 – SS T-Coolant Intercooler

ZKP-Number: 2.0124.932

Limit value 2

Cause	Corrective action
Coolant temperature in intercooler too high; engine shutdown.	▶ Reduce power.

015 – LO P-Lube Oil

ZKP-Number: 2.0100.921

Limit value 1

Cause	Corrective action
Lube oil pressure too low.	▶ Check oil level, top up as necessary (→ Page 169).

016 – SS P-Lube Oil

ZKP-Number: 2.0100.922

Limit value 2

Cause	Corrective action
Lube oil pressure too low; engine shutdown.	<ol style="list-style-type: none"> 1. Check oil level, top up as necessary (→ Page 169). 2. Attempt to restart engine (→ Page 55).

019 – HI T-Exhaust A

ZKP-Number: 2.0126.931

Limit value 1

Cause	Corrective action
Exhaust gas temperature (A-side) too high.	<ol style="list-style-type: none"> 1. Check cabling (→ Page 194). 2. Contact Service.

020 – SS T-Exhaust A

ZKP-Number: 2.0126.932

Limit value 2

Cause	Corrective action
Exhaust gas temperature (A-side) too high; engine shutdown.	<ol style="list-style-type: none"> 1. Check cabling (→ Page 194). 2. Contact Service.

021 – HI T-Exhaust B

ZKP-Number: 2.0127.931

Limit value 1

Cause	Corrective action
Exhaust gas temperature (B-side) too high.	1. Check cabling (→ Page 194). 2. Contact Service.

022 – SS T-Exhaust B

ZKP-Number: 2.0127.932

Limit value 2

Cause	Corrective action
Exhaust gas temperature (B-side) too high; engine shutdown.	1. Check cabling (→ Page 194). 2. Contact Service.

023 – LO Coolant Level

ZKP-Number: 2.0152.921

Limit value 1

Cause	Corrective action
Coolant level too low.	▶ Check coolant level in expansion tank (→ Page 176).

025 – HI P-Diff. Lube Oil

ZKP-Number: 2.0154.931

Limit value 1

Cause	Corrective action
Oil filter differential pressure too high.	▶ Replace oil filter (→ Page 173).

026 – HI P-Diff. Lube Oil

ZKP-Number: 2.0154.932

Limit value 2

Cause	Corrective action
Oil filter differential pressure too high.	▶ Replace oil filter (→ Page 173).

027 – HI Leak Fuel Level

ZKP-Number: 2.0151.931

Limit value 1

Cause	Corrective action
Leak-fuel level too high.	1. Check fuel system. 2. Contact Service.

029 – HI ETC 2 idle speed

ZKP-Number: 1.8004.206

Cause	Corrective action
Idle speed of ETC 2 too high.	▶ Contact Service.

030 – SS Engine Speed

ZKP-Number: 2.2510.932

Limit value 2

Cause	Corrective action
Reduced fuel injection.	1. Acknowledge alarm. 2. Attempt to restart engine.

031 – HI ETC 1 overspeed

ZKP-Number: 2.3011.931

Limit value 1

Cause	Corrective action
Speed of primary turbocharger too high.	▶ Contact Service.

032 – SS ETC 1 overspeed

ZKP-Number: 2.3012.932

Limit value 2

Cause	Corrective action
Speed of primary turbocharger too high.	1. Automatic power reduction by engine control system. 2. Check air filters (→ Page 164).

33 – HI P-Diff-Fuel

ZKP-Number: 20.114.931

Limit value 1

Cause	Corrective action
Fuel filter differential pressure too high.	▶ Replace fuel filter (→ Page 153).

34 – SS P-Diff-Fuel

ZKP-Number: 20.114.932

Limit value 2

Cause	Corrective action
Fuel filter differential pressure too high.	▶ Replace fuel filter (→ Page 153).

036 – HI ETC 2 Overspeed

ZKP-Number: 2.3013.931

Limit value 1

Cause	Corrective action
Speed of first secondary turbocharger too high.	1. Reduce power. 2. Contact Service.

037 – SS ETC 2 Overspeed

ZKP-Number: 2.3013.912

Limit value 2

Cause	Corrective action
Speed of first secondary turbocharger too high.	1. Reduce power. 2. Contact Service.

038 – AL ETC Speed Deviation

ZKP-Number: 1.8004.205

Cause	Corrective action
Synchronization fault between primary turbocharger and one of the secondary turbochargers.	1. Reduce power. 2. Contact Service.

039 – AL ETC 2 Cutin Failure

ZKP-Number: 1.8004.204

Cause	Corrective action
ETC 2 failed to cut in.	1. Reduce power. 2. Contact Service.

044 – LO Coolant Level Intercooler

ZKP-Number: 2.0153.921

Limit value 1

Cause	Corrective action
Intercooler coolant level too low.	▶ Check coolant level (→ Page 184).

051 – HI T-Lube Oil

ZKP-Number: 2.0125.931

Limit value 1

Cause	Corrective action
Lube oil temperature too high.	▶ Reduce power.

052 – SS T-Lube Oil

ZKP-Number: 2.0125.932

Limit value 2

Cause	Corrective action
Lube oil temperature too high; engine shutdown.	1. Reduce power. 2. Check engine oil level (→ Page 169).

057 – LO P-Coolant

ZKP-Number: 2.0101.921

Limit value 1

Cause	Corrective action
Coolant pressure too low.	▶ Check coolant circuit.

058 – SS P-Coolant

ZKP-Number: 2.0101.922

Limit value 2

Cause	Corrective action
Coolant pressure too low; engine shutdown or reduction of fuel injection.	1. Automatic engine shutdown. 2. Check coolant level (→ Page 176).

59 – SS T-Coolant L3

ZKP-Number: 20.120.933

Limit value 3

Cause	Corrective action
Coolant temperature too high/low	1. Allow engine to cool down; 2. Check coolant cooler, clean if necessary. 3. Contact Service.

067 – HI T-Coolant

ZKP-Number: 2.0120.931

Limit value 1

Cause	Corrective action
Coolant temperature too high.	▶ Reduce power.

068 – SS T-Coolant

ZKP-Number: 2.0120.932

Limit value 2

Cause	Corrective action
Coolant temperature too high; engine shutdown.	<ol style="list-style-type: none"> 1. Allow engine to cool down; 2. Check coolant cooler, clean if necessary. 3. Restart engine (→ Page 55). 4. Contact Service.

081 – AL Rail Leakage

ZKP-Number: 1.8004.046

Cause	Corrective action
Pressure gradient in common rail too low during engine start or too high during engine stop; HP fuel system leaky, air in system.	▶ Contact Service.

082 – HI P-Fuel (Common Rail)

ZKP-Number: 2.0104.931

Cause	Corrective action
Rail pressure > set-point value; DBR reduction, start of injection moved to late; suction restrictor jamming or wiring of suction restrictor faulty.	▶ Contact Service.

083 – LO P-Fuel (Common Rail)

ZKP-Number: 2.0104.921

Cause	Corrective action
Rail pressure > set-point value; DBR reduction, suction restrictor faulty or leak in HP fuel system.	▶ Contact Service.

085 – HI T-Recirculation

ZKP-Number: 2.0128.931

Limit value 1

Cause	Corrective action
Recirculation temperature too high.	▶ Reduce power.

086 – HI T-Recirculation

ZKP-Number: 2.0128.932

Limit value 2

Cause	Corrective action
Recirculation temperature too high.	▶ Reduce power.

089 – SS Engine Speed too Low

ZKP-Number: 2.2500.030

Cause	Corrective action
Engine speed too low.	▶ Check for additional messages.

090 – SS Starter Speed Not Reached

ZKP-Number: 2.1090.925

Cause	Corrective action
Idling speed was not attained.	▶ Contact Service.

091 – SS Release Speed Not Reached

ZKP-Number: 2.1090.924

Cause	Corrective action
Runup speed was not attained.	▶ Contact Service.

092 – SS Starter Speed Not Reached

ZKP-Number: 2.1090.923

Cause	Corrective action
Starter speed was not attained; termination of start sequence; starter rotates too low or not at all.	▶ Contact Service.

093 – SS T-Preheat

ZKP-Number: 2.1090.922

Limit value 2

Cause	Corrective action
Preheating temperature too low; coolant temperature too low for engine start ; engine start interlock.	▶ Check preheater.

094 – LO T-Preheat

ZKP-Number: 2.1090.921

Limit value 1

Cause	Corrective action
Preheating temperature too low; coolant temperature too low for engine start.	▶ Check preheater.

095 – AL Prelubrication Fault

ZKP-Number: 2.1090.920

Cause	Corrective action
oil priming failure.	▶ Check oil priming system.

102 – AL Consumption Meter Faulty

ZKP-Number: 1.8004.624

Cause	Corrective action
consumption meter faulty.	▶ Contact Service.

104 – AL Eng Hours Counter Defect

ZKP-Number: 1.8004.623

Cause	Corrective action
hour meter faulty.	▶ Contact Service.

118 – LO ECU Supply Voltage

ZKP-Number: 2.0140.921

Limit value 1

Cause	Corrective action
Supply voltage too low.	1. Check ECU supply voltage. 2. Contact Service.

142 – AL MCR exceeded 1 hour

ZKP-Number: 1.1088.006

Cause	Corrective action
This alarm is activated when the MCR was exceeded for more than one hour within the last 12 hours.	▶ Reduce power.

176 – AL LifeData Not Avail

ZKP-Number: 2.4000.004

Cause	Corrective action
No (appropriate) LifeData backup system available, ECU reset after expiration of time-out period.	▶ Contact Service.

177 – AL LifeData restore incomplete

ZKP-Number: 2.4000.006

Cause	Corrective action
This error message is generated if a CRC is faulty during a data upload to ADEC (indicated for each individual module).	▶ Contact Service.

180 – AL CAN1 Node Lost

ZKP-Number: 2.0500.680

Cause	Corrective action
Connection to one node on CAN bus 1 failed.	▶ Contact Service.

181 – AL CAN2 Node Lost

ZKP-Number: 2.0500.681

Cause	Corrective action
Connection to one node on CAN bus 2 failed.	▶ Contact Service.

182 – AL CAN Wrong Parameters

ZKP-Number: 2.0500.682

Cause	Corrective action
Incorrect parameter values entered in data record.	▶ Contact Service.

189 – AL CAN2 Error Passive

ZKP-Number: 2.0500.689

Cause	Corrective action
CAN controller 2 has signaled a warning.	<ol style="list-style-type: none"> 1. Inspect CAN bus for short circuit and rectify short circuit as necessary. 2. Check shielding, improve as necessary. 3. Contact Service.

190 – AL EMU Parameter Not Supported

ZKP-Number: 2.0500.690

Cause	Corrective action
EMU parameter are not supported.	▶ Contact Service.

201 – SD T-Coolant

ZKP-Number: 1.8004.570

Cause	Corrective action
Coolant temperature sensor faulty; short circuit or wire break.	▶ Check sensor and cabling (B6), replace as necessary. Error cleared after restarting the engine.

202 – SD T-Fuel

ZKP-Number: 1.8004.572

Cause	Corrective action
Fuel temperature sensor faulty; short circuit or wire break.	▶ Check sensor and cabling (B33), replace as necessary. Error cleared after restarting the engine.

203 – SD T-Charge Air

ZKP-Number: 1.8004.571

Cause	Corrective action
Charge-air temperature sensor faulty; short circuit or wire break.	▶ Check sensor and cabling (B9), replace as necessary. Error cleared after restarting the engine.

204 – SD Level Lube Oil

ZKP-Number: 1.8004.602

Cause	Corrective action
Lube-oil level sensor faulty; short circuit or wire break.	▶ Check sensor and cabling, replace as necessary.

213 – SD P-Coolant Intercooler

ZKP-Number: 1.8004.569

Cause	Corrective action
Coolant pressure sensor of intercooler faulty; short circuit or wire break.	▶ Check sensor and cabling (B43), replace as necessary. Error cleared after restarting the engine.

214 – SD P-CrankCase

ZKP-Number: 1.8004.568

Cause	Corrective action
Crankcase pressure sensor faulty; short circuit or wire break.	▶ Check sensor and cabling (B50), replace as necessary. Error cleared after restarting the engine.

215 – SD P-HD

ZKP-Number: 1.8004.567

Cause	Corrective action
Rail pressure sensor faulty; HP fuel regulator in emergency mode==> short circuit or wire break.	▶ Check sensor and cabling (B48), replace as necessary. Error cleared after restarting the engine.

216 – SD T-Lube Oil

ZKP-Number: 1.8004.575

Cause	Corrective action
Lube-oil temperature sensor faulty; short circuit or wire break.	▶ Check sensor and cabling (B7), replace as necessary. Error cleared after restarting the engine.

219 – SD T-Intake Air

ZKP-Number: 1.8004.573

Cause	Corrective action
Intake air temperature sensor faulty; short circuit or wire break.	▶ Check sensor and cabling (B3), replace as necessary. Error cleared after restarting the engine.

220 – SD Coolant Level

ZKP-Number: 1.8004.584

Cause	Corrective action
Coolant level sensor faulty; short circuit or wire break.	▶ Check sensor and cabling (F33), replace as necessary. Error cleared after restarting the engine.

221 – HI P-Diff Lube Oil

ZKP-Number: 1.8004.585

Cause	Corrective action
Lube-oil differential pressure sensor faulty; short circuit or wire break.	▶ Check sensor and cabling (F25), replace as necessary. Error cleared after restarting the engine.

222 – SD Level Leakage Fuel

ZKP-Number: 1.8004.582

Cause	Corrective action
Leak-fuel level sensor faulty; short circuit or wire break.	▶ Check sensor and cabling (F46), replace as necessary. Error cleared after restarting the engine.

223 – SD Level Coolant Intercooler

ZKP-Number: 1.8004.583

Cause	Corrective action
Coolant level sensor of intercooler faulty; short circuit or wire break.	▶ Check sensor and cabling (F57), replace as necessary. Error cleared after restarting the engine.

227 – SD P-Oil bef. Filter

ZKP-Number: 1.8004.620

Cause	Corrective action
Lube-oil pressure sensor before filter faulty; short circuit or wire break.	▶ Check sensor and cabling (B5.3), replace as necessary. Error cleared after restarting the engine.

228 – SD P-Fuel before Filter

ZKP-Number: 18.004.595

Cause	Corrective action
Fuel pressure sensor faulty; short circuit or wire break.	▶ Check sensor and cabling (B5.3), replace as necessary.

229 – AL Stop Camshaft Sensor Defect

ZKP-Number: 1.8004.562

Cause	Corrective action
engine stop due to camshaft sensor fault (and a prior crankshaft sensor fault in the same operating cycle).	▶ Check connector and cabling to sensor B1, replace as necessary. Error cleared after restarting the engine.

230 – SD Crankshaft Speed

ZKP-Number: 1.8004.498

Cause	Corrective action
Crankshaft speed sensor faulty; short circuit or wire break.	▶ Check sensor and cabling (B13), replace as necessary. Error cleared after restarting the engine.

231 – SD Camshaft Speed

ZKP-Number: 1.8004.499

Cause	Corrective action
Camshaft speed sensor faulty; short circuit or wire break.	▶ Check sensor and cabling (B1), replace as necessary. Error cleared after restarting the engine.

232 – SD Charger 1 Speed

ZKP-Number: 1.3011.128.

Cause	Corrective action
Speed sensor of primary turbocharger faulty; short circuit or wire break.	▶ Check sensor and cabling (B44.1), replace as necessary. Error cleared after restarting the engine.

233 – SD Charger 2 Speed

ZKP-Number: 1.3011.129

Cause	Corrective action
Speed sensor of secondary turbocharger faulty; short circuit or wire break.	▶ Check sensor and cabling (B44.2), replace as necessary. Error cleared after restarting the engine.

239 – SD P-Diff Fuel

ZKP-Number: 18.004.598

Cause	Corrective action
Fuel differential pressure sensor faulty. This alarm occurs only in combination with the alarm SD P-Fuel before Filter or SD P-Fuel after Filter.	▶ Note further fault messages.

268 – SD Spinning Value

ZKP-Number: 28.006.591

Cause	Corrective action
Analog wheel slip signal faulty; short circuit or wire break.	▶ Check sensor and cabling, replace as necessary.

269 – SD Loadp.Analog filt

ZKP-Number: 2.8006.588

Cause	Corrective action
Filtered analog load pulse signal missing; short circuit or wire break.	▶ Check cabling, replace as necessary. Error cleared after restarting the engine.

270 – SD Frequency Input

ZKP-Number: 2.8006.590

Cause	Corrective action
Frequency input faulty; short circuit or wire break.	<ol style="list-style-type: none"> 1. Check cabling. 2. Check setpoint speed transmitter. 3. Contact Service.

301 – AL Timing Cylinder A1

ZKP-Number: 1.8004.500

Cause	Corrective action
Time-of-flight measuring fault of injector: time-of flight measured value extremely low or extremely high.	▶ Replace injector concerned if the fault message appears frequently (→ Page 146).

302 – AL Timing Cylinder A2

ZKP-Number: 1.8004.501

Cause	Corrective action
Time-of-flight measuring fault of injector: time-of flight measured value extremely low or extremely high.	▶ Replace injector concerned if the fault message appears frequently (→ Page 146).

303 – AL Timing Cylinder A3

ZKP-Number: 1.8004.502

Cause	Corrective action
Time-of-flight measuring fault of injector: time-of flight measured value extremely low or extremely high.	▶ Replace injector concerned if the fault message appears frequently (→ Page 146).

304 – AL Timing Cylinder A4

ZKP-Number: 1.8004.503

Cause	Corrective action
Time-of-flight measuring fault of injector: time-of flight measured value extremely low or extremely high.	▶ Replace injector concerned if the fault message appears frequently (→ Page 146).

305 – AL Timing Cylinder A5

ZKP-Number: 1.8004.504

Cause	Corrective action
Time-of-flight measuring fault of injector: time-of flight measured value extremely low or extremely high.	▶ Replace injector concerned if the fault message appears frequently (→ Page 146).

306 – AL Timing Cylinder A6

ZKP-Number: 1.8004.505

Cause	Corrective action
Time-of-flight measuring fault of injector: time-of flight measured value extremely low or extremely high.	▶ Replace injector concerned if the fault message appears frequently (→ Page 146).

307 – AL Timing Cylinder A7

ZKP-Number: 1.8004.506

Cause	Corrective action
Time-of-flight measuring fault of injector: time-of flight measured value extremely low or extremely high.	▶ Replace injector concerned if the fault message appears frequently (→ Page 146).

308 – AL Timing Cylinder A8

ZKP-Number: 1.8004.507

Cause	Corrective action
Time-of-flight measuring fault of injector: time-of flight measured value extremely low or extremely high.	▶ Replace injector concerned if the fault message appears frequently (→ Page 146).

309 – AL Timing Cylinder A9

ZKP-Number: 1.8004.508

Cause	Corrective action
Time-of-flight measuring fault of injector: time-of flight measured value extremely low or extremely high.	▶ Replace injector concerned if the fault message appears frequently (→ Page 146).

310 – AL Timing Cylinder A10

ZKP-Number: 1.8004.509

Cause	Corrective action
Time-of-flight measuring fault of injector: time-of flight measured value extremely low or extremely high.	▶ Replace injector concerned if the fault message appears frequently (→ Page 146).

311 – AL Timing Cylinder B1

ZKP-Number: 1.8004.510

Cause	Corrective action
Time-of-flight measuring fault of injector: time-of flight measured value extremely low or extremely high.	▶ Replace injector concerned if the fault message appears frequently (→ Page 146).

312 – AL Timing Cylinder B2

ZKP-Number: 1.8004.511

Cause	Corrective action
Time-of-flight measuring fault of injector: time-of flight measured value extremely low or extremely high.	▶ Replace injector concerned if the fault message appears frequently (→ Page 146).

313 – AL Timing Cylinder B3

ZKP-Number: 1.8004.512

Cause	Corrective action
Time-of-flight measuring fault of injector: time-of flight measured value extremely low or extremely high.	▶ Replace injector concerned if the fault message appears frequently (→ Page 146).

314 – AL Timing Cylinder B4

ZKP-Number: 1.8004.513

Cause	Corrective action
Time-of-flight measuring fault of injector: time-of flight measured value extremely low or extremely high.	▶ Replace injector concerned if the fault message appears frequently (→ Page 146).

315 – AL Timing Cylinder B5

ZKP-Number: 1.8004.514

Cause	Corrective action
Time-of-flight measuring fault of injector: time-of flight measured value extremely low or extremely high.	▶ Replace injector concerned if the fault message appears frequently (→ Page 146).

316 – AL Timing Cylinder B6

ZKP-Number: 1.8004.515

Cause	Corrective action
Time-of-flight measuring fault of injector: time-of flight measured value extremely low or extremely high.	▶ Replace injector concerned if the fault message appears frequently (→ Page 146).

317 – AL Timing Cylinder B7

ZKP-Number: 1.8004.516

Cause	Corrective action
Time-of-flight measuring fault of injector: time-of flight measured value extremely low or extremely high.	▶ Replace injector concerned if the fault message appears frequently (→ Page 146).

318 – AL Timing Cylinder B8

ZKP-Number: 1.8004.517

Cause	Corrective action
Time-of-flight measuring fault of injector: time-of flight measured value extremely low or extremely high.	▶ Replace injector concerned if the fault message appears frequently (→ Page 146).

319 – AL Timing Cylinder B9

ZKP-Number: 1.8004.518

Cause	Corrective action
Time-of-flight measuring fault of injector: time-of flight measured value extremely low or extremely high.	▶ Replace injector concerned if the fault message appears frequently (→ Page 146).

320 – AL Timing Cylinder B10

ZKP-Number: 1.8004.519

Cause	Corrective action
Time-of-flight measuring fault of injector: time-of flight measured value extremely low or extremely high.	▶ Replace injector concerned if the fault message appears frequently (→ Page 146).

321 – AL Wiring Cylinder A1

ZKP-Number: 1.8004.520

Cause	Corrective action
Cabling fault in injector cabling to cylinder. Result: misfiring.	1. Check solenoid valve. 2. Contact Service.

322 – AL Wiring Cylinder A2

ZKP-Number: 1.8004.521

Cause	Corrective action
Cabling fault in injector cabling to cylinder. Result: misfiring.	1. Check solenoid valve. 2. Contact Service.

323 – AL Wiring Cylinder A3

ZKP-Number: 1.8004.522

Cause	Corrective action
Cabling fault in injector cabling to cylinder. Result: misfiring.	<ol style="list-style-type: none"> 1. Check solenoid valve. 2. Contact Service.

324 – AL Wiring Cylinder A4

ZKP-Number: 1.8004.523

Cause	Corrective action
Cabling fault in injector cabling to cylinder. Result: misfiring.	<ol style="list-style-type: none"> 1. Check solenoid valve. 2. Contact Service.

325 – AL Wiring Cylinder A5

ZKP-Number: 1.8004.524

Cause	Corrective action
Cabling fault in injector cabling to cylinder. Result: misfiring.	<ol style="list-style-type: none"> 1. Check solenoid valve. 2. Contact Service.

326 – AL Wiring Cylinder A6

ZKP-Number: 1.8004.525

Cause	Corrective action
Cabling fault in injector cabling to cylinder. Result: misfiring.	<ol style="list-style-type: none"> 1. Check solenoid valve. 2. Contact Service.

327 – AL Wiring Cylinder A7

ZKP-Number: 1.8004.526

Cause	Corrective action
Cabling fault in injector cabling to cylinder. Result: misfiring.	<ol style="list-style-type: none"> 1. Check solenoid valve. 2. Contact Service.

328 – AL Wiring Cylinder A8

ZKP-Number: 1.8004.527

Cause	Corrective action
Cabling fault in injector cabling to cylinder. Result: misfiring.	<ol style="list-style-type: none"> 1. Check solenoid valve. 2. Contact Service.

329 – AL Wiring Cylinder A9

ZKP-Number: 1.8004.528

Cause	Corrective action
Cabling fault in injector cabling to cylinder. Result: misfiring.	1. Check solenoid valve. 2. Contact Service.

330 – AL Wiring Cylinder A10

ZKP-Number: 1.8004.529

Cause	Corrective action
Cabling fault in injector cabling to cylinder. Result: misfiring.	1. Check solenoid valve. 2. Contact Service.

331 – AL Wiring Cylinder B1

ZKP-Number: 1.8004.530

Cause	Corrective action
Cabling fault in injector cabling to cylinder. Result: misfiring.	1. Check solenoid valve. 2. Contact Service.

332 – AL Wiring Cylinder B2

ZKP-Number: 1.8004.531

Cause	Corrective action
Cabling fault in injector cabling to cylinder. Result: misfiring.	1. Check solenoid valve. 2. Contact Service.

333 – AL Wiring Cylinder B3

ZKP-Number: 1.8004.532

Cause	Corrective action
Cabling fault in injector cabling to cylinder. Result: misfiring.	1. Check solenoid valve. 2. Contact Service.

334 – AL Wiring Cylinder B4

ZKP-Number: 1.8004.533

Cause	Corrective action
Cabling fault in injector cabling to cylinder. Result: misfiring.	1. Check solenoid valve. 2. Contact Service.

335 – AL Wiring Cylinder B5

ZKP-Number: 1.8004.534

Cause	Corrective action
Cabling fault in injector cabling to cylinder. Result: misfiring.	1. Check solenoid valve. 2. Contact Service.

336 – AL Wiring Cylinder B6

ZKP-Number: 1.8004.535

Cause	Corrective action
Cabling fault in injector cabling to cylinder. Result: misfiring.	1. Check solenoid valve. 2. Contact Service.

337 – AL Wiring Cylinder B7

ZKP-Number: 1.8004.536

Cause	Corrective action
Cabling fault in injector cabling to cylinder. Result: misfiring.	1. Check solenoid valve. 2. Contact Service.

338 – AL Wiring Cylinder B8

ZKP-Number: 1.8004.537

Cause	Corrective action
Cabling fault in injector cabling to cylinder. Result: misfiring.	1. Check solenoid valve. 2. Contact Service.

339 – AL Wiring Cylinder B9

ZKP-Number: 1.8004.538

Cause	Corrective action
Cabling fault in injector cabling to cylinder. Result: misfiring.	1. Check solenoid valve. 2. Contact Service.

340 – AL Wiring Cylinder B10

ZKP-Number: 1.8004.539

Cause	Corrective action
Cabling fault in injector cabling to cylinder. Result: misfiring.	1. Check solenoid valve. 2. Contact Service.

341 – AL Open Load Cylinder A1

ZKP-Number: 1.8004.540

Cause	Corrective action
Disruption fault in injector cabling to cylinder. Result: misfiring.	1. Check solenoid valve. 2. Contact Service.

342 – AL Open Load Cylinder A2

ZKP-Number: 1.8004.541

Cause	Corrective action
Disruption fault in injector cabling to cylinder. Result: misfiring.	1. Check solenoid valve. 2. Contact Service.

343 – AL Open Load Cylinder A3

ZKP-Number: 1.8004.542

Cause	Corrective action
Disruption fault in injector cabling to cylinder. Result: misfiring.	1. Check solenoid valve. 2. Contact Service.

344 – AL Open Load Cylinder A4

ZKP-Number: 1.8004.543

Cause	Corrective action
Disruption fault in injector cabling to cylinder. Result: misfiring.	1. Check solenoid valve. 2. Contact Service.

345 – AL Open Load Cylinder A5

ZKP-Number: 1.8004.544

Cause	Corrective action
Disruption fault in injector cabling to cylinder. Result: misfiring.	1. Check solenoid valve. 2. Contact Service.

346 – AL Open Load Cylinder A6

ZKP-Number: 1.8004.545

Cause	Corrective action
Disruption fault in injector cabling to cylinder. Result: misfiring.	1. Check solenoid valve. 2. Contact Service.

353 – AL Open Load Cylinder B3

ZKP-Number: 1.8004.552

Cause	Corrective action
Disruption fault in injector cabling to cylinder. Result: misfiring.	1. Check solenoid valve. 2. Contact Service.

354 – AL Open Load Cylinder B4

ZKP-Number: 1.8004.553

Cause	Corrective action
Disruption fault in injector cabling to cylinder. Result: misfiring.	1. Check solenoid valve. 2. Contact Service.

355 – AL Open Load Cylinder B5

ZKP-Number: 1.8004.554

Cause	Corrective action
Disruption fault in injector cabling to cylinder. Result: misfiring.	1. Check solenoid valve. 2. Contact Service.

356 – AL Open Load Cylinder B6

ZKP-Number: 1.8004.555

Cause	Corrective action
Disruption fault in injector cabling to cylinder. Result: misfiring.	1. Check solenoid valve. 2. Contact Service.

357 – AL Open Load Cylinder B7

ZKP-Number: 1.8004.556

Cause	Corrective action
Disruption fault in injector cabling to cylinder. Result: misfiring.	1. Check solenoid valve. 2. Contact Service.

358 – AL Open Load Cylinder B8

ZKP-Number: 1.8004.557

Cause	Corrective action
Disruption fault in injector cabling to cylinder. Result: misfiring.	1. Check solenoid valve. 2. Contact Service.

365 – AL Stop MV-Wiring Ground

ZKP-Number: 1.8004.561

Cause	Corrective action
Injector cabling fault. If bit "1.1020.021" (Power Stage Failure: stop engine) is set, engine will be shut down as additional measure. 1. Short circuit of positive connection of one or more injectors to ground 2. Short circuit of negative connection of one or more injectors to ground .	<ol style="list-style-type: none"> 1. Check cabling. 2. Attempt to restart engine.

371 – AL Wiring TO 1

ZKP-Number: 1.8004.634

Cause	Corrective action
Short circuit or wire break on transistor output 1 (TO 1).	<ol style="list-style-type: none"> 1. Check turbocharger valve/cabling, repair as necessary. 2. Replace ECU.

372 – AL Wiring TO 2

ZKP-Number: 1.8004.635

Cause	Corrective action
Short circuit or wire break on transistor output 2 (TO 2).	<ol style="list-style-type: none"> 1. Check recirculation valve/cabling, repair as necessary. 2. Replace ECU.

373 – AL Wiring TO 3

ZKP-Number: 1.8004.636

Cause	Corrective action
Short circuit or wire break on transistor output 3 (TO 3).	▶ -

374 – AL Wiring TO 4

ZKP-Number: 1.8004.637

Cause	Corrective action
Short circuit or wire break on transistor output 4 (TO 4).	▶ -

381 – AL Wiring TOP 1

ZKP-Number: 2.8006.638

Cause	Corrective action
Short circuit or wire break on transistor output, plant-side 1 (TOP 1).	▶ Check cabling to plant.

382 – AL Wiring TOP 2

ZKP-Number: 2.8006.639

Cause	Corrective action
Short circuit or wire break on transistor output, plant-side 2 (TOP 2).	▶ Check cabling to plant.

383 – AL Wiring TOP 3

ZKP-Number: 2.8006.640

Cause	Corrective action
Short circuit or wire break on transistor output, plant-side 3 (TOP 3).	▶ Check cabling to plant.

384 – AL Wiring TOP 4

ZKP-Number: 2.8006.641

Cause	Corrective action
Short circuit or wire break on transistor output, plant-side 4 (TOP 4).	▶ Check cabling to plant.

390 – AL MCR exceeded

ZKP-Number: 1.1085.009

Cause	Corrective action
DBR/MCR function: MCR has been exceeded.	1. If alarm is only temporary, no action required; 2. if alarm is continuously active, contact Service.

392 – HI T-Coolant Red

ZKP-Number: 2.0129.931

Limit value 1

Cause	Corrective action
Redundant coolant temperature reading too high.	1. Check cabling. 2. Contact Service.

393 – SS T-Coolant Red

ZKP-Number: 2.0129.932

Limit value 2

Cause	Corrective action
Redundant coolant temperature reading too high; engine shutdown.	1. Check cabling and sensor. 2. Contact Service.

394 – LO P-Lube Oil Red

ZKP-Number: 2.0112.921

Limit value 1

Cause	Corrective action
Redundant lube oil pressure reading too low.	1. Check cabling and sensor. 2. Contact Service.

395 – SS P-Lube Oil Red

ZKP-Number: 2.0112.922

Limit value 2

Cause	Corrective action
Redundant lube oil pressure reading too low.	1. Check cabling and sensor. 2. Contact Service.

396 – TD T-Coolant Sensor Deviation

ZKP-Number: 1.0480.193

Cause	Corrective action
Maximum coolant temperature deviation.	1. Check cabling and sensor. 2. Contact Service.

397 – TD P-Oil Sensor Deviation

ZKP-Number: 1.0480.293

Cause	Corrective action
Maximum lube oil pressure deviation.	1. Check cabling and sensor. 2. Contact Service.

400 – AL Open Load Digital Input 1

ZKP-Number: 2.8006.625

Cause	Corrective action
Open circuit at digital input 1; cabling faulty or no resistance across the switch.	1. Check cabling. 2. Check input of target device. 3. Contact Service.

401 – AL Open Load Digital Input 2

ZKP-Number: 2.8006.626

Cause	Corrective action
Open circuit at digital input 2; cabling faulty or no resistance across the switch.	<ol style="list-style-type: none"> 1. Check cabling. 2. Check input of target device. 3. Contact Service.

402 – AL Open Load Digital Input 3

ZKP-Number: 2.8006.627

Cause	Corrective action
Open circuit at digital input 3; cabling faulty or no resistance across the switch.	<ol style="list-style-type: none"> 1. Check cabling. 2. Check input of target device. 3. Contact Service.

403 – AL Open Load Digital Input 4

ZKP-Number: 2.8006.628

Cause	Corrective action
Open circuit at digital input 4; cabling faulty or no resistance across the switch.	<ol style="list-style-type: none"> 1. Check cabling. 2. Check input of target device. 3. Contact Service.

404 – AL Open Load Digital Input 5

ZKP-Number: 2.8006.629

Cause	Corrective action
Open circuit at digital input 5; cabling faulty or no resistance across the switch.	<ol style="list-style-type: none"> 1. Check cabling. 2. Check input of target device. 3. Contact Service.

405 – AL Open Load Digital Input 6

ZKP-Number: 2.8006.630

Cause	Corrective action
Open circuit at digital input 6; cabling faulty or no resistance across the switch.	<ol style="list-style-type: none"> 1. Check cabling. 2. Check input of target device. 3. Contact Service.

406 – AL Open Load Digital Input 7

ZKP-Number: 2.8006.631

Cause	Corrective action
Open circuit at digital input 7; cabling faulty or no resistance across the switch.	<ol style="list-style-type: none"> 1. Check cabling. 2. Check input of target device. 3. Contact Service.

407 – AL Open Load Digital Input 8

ZKP-Number: 2.8006.632

Cause	Corrective action
Open circuit at digital input 8; cabling faulty or no resistance across the switch.	<ol style="list-style-type: none"> 1. Check cabling. 2. Check input of target device. 3. Contact Service.

408 – AL Open Load Emerg. Stop Input ESI

ZKP-Number: 2.8006.633

Cause	Corrective action
Open circuit at input for emergency stop; cabling faulty or no resistance across the switch.	<ol style="list-style-type: none"> 1. Check cabling. 2. Check input of target device. 3. Contact Service.

410 – LO U-PDU

ZKP-Number: 2.0141.921

Limit value 1

Cause	Corrective action
Injector voltage too low.	<ol style="list-style-type: none"> 1. Check cabling. 2. Check power supply. 3. Contact Service.

411 – LOLO U-PDU

ZKP-Number: 2.0141.922

Limit value 2

Cause	Corrective action
Injector voltage too low.	<ol style="list-style-type: none"> 1. Check cabling. 2. Check power supply. 3. Contact Service.

412 – HI U-PDU

ZKP-Number: 2.0141.931

Limit value 1

Cause	Corrective action
Injector voltage too high.	1. Check cabling. 2. Check power supply. 3. Contact Service.

413 – HIHI U-PDU

ZKP-Number: 2.0141.932

Limit value 2

Cause	Corrective action
Injector voltage too high.	1. Check cabling. 2. Check power supply. 3. Contact Service.

414 – HI Water Level Fuel Prefilter

ZKP-Number: 2.0156.931

Limit value 1

Cause	Corrective action
Water level in fuel prefilter too high.	▶ Drain water (→ Page 156).

415 – LO P-Coolant Intercooler

ZKP-Number: 2.0107.921

Limit value 1

Cause	Corrective action
Coolant pressure in intercooler too low.	▶ Top up coolant (→ Page 187).

416 – SS P-Coolant Intercooler

ZKP-Number: 2.0107.922

Limit value 2

Cause	Corrective action
Coolant pressure in intercooler too low; engine shutdown.	▶ Top up coolant (→ Page 187).

417 – SD Water Level Fuel Prefilter

ZKP-Number: 1.8004.594

Cause	Corrective action
Water level sensor of fuel prefilter faulty; short circuit or wire break.	▶ Check sensor and cabling, replace as necessary. Error cleared after restarting the engine.

419 – SD T-Coolant b.Engine

ZKP-Number: 18.004.604

Cause	Corrective action
Coolant inlet temperature sensor faulty, short circuit or wire break.	▶ Check sensor and cabling (B3), replace as necessary.

420 – AL L1 Aux 1

ZKP-Number: 2.0160.921.

Limit value 1

Cause	Corrective action
Input signal of Aux 1 has exceeded/not attained limit value 1, depending on configuration.	▶ Determine and rectify reason for limit value violation.

421 – AL L2 Aux 1

ZKP-Number: 2.0160.922

Limit value 2

Cause	Corrective action
Input signal of Aux 1 has exceeded/not attained limit value 2, depending on configuration.	▶ Determine and rectify reason for limit value violation.

428 – AL L1 T-Aux 1

ZKP-Number: 2.0130.921

Limit value 1

Cause	Corrective action
Temperature signal of Aux 1 has exceeded / not attained limit value 1, depending on configuration.	▶ Determine and rectify reason for limit value violation.

442 – AL L2 P-Aux 1

ZKP-Number: 2.0110.931

Limit value 2

Cause	Corrective action
Pressure signal of Aux 1 has exceeded / not attained limit value 2, depending on configuration.	► Determine and rectify reason for limit value violation.

444 – SD U-PDU

ZKP-Number: 1.8004.578

Cause	Corrective action
Sensor defect of injector power stage; internal fault of engine governor.	► Replace ECU.

445 – SD P-Ambient Air

ZKP-Number: 1.8004.580

Cause	Corrective action
ambient air pressure sensor faulty.	► Replace ECU.

448 – HI P-Charge Air

ZKP-Number: 2.0103.931

Limit value 1

Cause	Corrective action
Charge-air pressure too high.	► Contact Service.

449 – SS P-Charge Air

ZKP-Number: 2.0103.932

Limit value 2

Cause	Corrective action
Charge-air pressure too high.	► Contact Service.

450 – SD Idle/End-Torque Input [%]

ZKP-Number: 2.8006.592

Cause	Corrective action
Input signal for idle/end torque faulty; short circuit or wire break.	► Check signal transmitter and cabling, replace as necessary. Error cleared after restarting the engine.

462 – HI T-Coolant EMU

ZKP-Number: 2.8006.654

Limit value 1

Cause	Corrective action
EMU coolant temperature value too high / low.	▶ Check configuration with DiaSys.

464 – SD P-AUX 1

ZKP-Number: 1.8004.589

Cause	Corrective action
Analog pressure input signal for Aux 1 faulty; short circuit or wire break.	▶ Check pressure transmitter and cabling, replace as necessary. Error cleared after restarting the engine.

467 – AL L2 T-Aux 1

ZKP-Number: 2.0130.922

Limit value 2

Cause	Corrective action
Temperature signal of Aux 1 has exceeded / not attained limit value 2, depending on configuration.	▶ Determine and rectify reason for limit value violation.

468 – SD T-AUX 1

ZKP-Number: 1.8004.579

Cause	Corrective action
Analog input for Aux 1 temperature faulty.	▶ Replace ECU.

469 – SD AUX 1

ZKP-Number: 1.8004.590

Cause	Corrective action
Analog input signal for Aux 1 faulty; short circuit or wire break.	▶ Check signal transmitter and cabling, replace as necessary. Error cleared after restarting the engine.

470 – SD T-ECU

ZKP-Number: 1.8004.587

Cause	Corrective action
Temperature sensor for ECU faulty; short circuit or wire break.	▶ Check sensor and cabling, replace as necessary. Error cleared after restarting the engine.

471 – SD Coil Current

ZKP-Number: 1.8004.592

Cause	Corrective action
Control circuit for suction restrictor faulty; short circuit or wire break.	▶ Check sensor and cabling, replace as necessary. Error cleared after restarting the engine.

472 – AI Stop SD

ZKP-Number: 2.8006.593

Cause	Corrective action
Engine shutdown, since all shutdown channels have "sensor faulty".	1. Check cabling. 2. Contact Service.

473 – AL Cabling PWM_CM2

ZKP-Number: 1.8004.593

Cause	Corrective action
Cable break or short circuit on channel PWM_CM2.	1. Check cabling. 2. Contact Service.

474 – AL Wiring FO

ZKP-Number: 2.8006.655

Cause	Corrective action
Cable break or short circuit on channel FO.	1. Check cabling. 2. Contact Service.

475 – AL CR Trigger Engine Stop

ZKP-Number: 1.8010.009

Cause	Corrective action
Tripped by crash recorder triggering due to engine shutdown.	▶ Determine and rectify cause of triggering / engine shutdown.

476 – AL Crash Rec. Init. Error

ZKP-Number: 1.8010.007

Cause	Corrective action
Crash recorder initialization error.	▶ Check setting with DiaSys.

478 – AL Comb. Alarm Yel (Plant)

ZKP-Number: 2.8006.001

Cause	Corrective action
Combined alarm YELLOW from plant.	▶ Note further fault messages.

479 – AL Comb. Alarm Red (Plant)

ZKP-Number: 2.8006.002

Cause	Corrective action
Combined alarm RED from plant.	▶ Note further fault messages.

480 – AL Ext. Engine Protection

ZKP-Number: 20.291.921

Cause	Corrective action
External engine protection function is active.	▶ Monitoring of plant signal by ECU is active (plant-side). Check plant signal.

482 – SD T-Exhaust C

ZKP-Number: 18.004.596

Cause	Corrective action
Exhaust temperature sensor on A-side faulty; short circuit or wire break.	▶ Check sensor and cabling (B4.23), replace as necessary.

483 – SD T-Exhaust D

ZKP-Number: 18.004.597

Cause	Corrective action
Exhaust temperature sensor on A-side faulty; short circuit or wire break.	▶ Check sensor and cabling (B4.24), replace as necessary.

484 – HI T-Exhaust C

ZKP-Number: 20.133.931

Limit value 1

Cause	Corrective action
Exhaust gas temperature (C-side) too high.	1. Reduce power. 2. Contact Service.

490 – HI ETC4 Overspeed

ZKP-Number: 23.015.931

Limit value 1

Cause	Corrective action
Speed of third secondary turbocharger too high.	▶ Reduce power.

491 – SS ETC4 Overspeed

ZKP-Number: 23.015.932

Limit value 2

Cause	Corrective action
Speed of third secondary turbocharger too high.	▶ Reduce power.

492 – AL ETC4 CutIn Failure

ZKP-Number: 18.004.202

Cause	Corrective action
ETC 4 failed to cut in.	▶ Check control valve on turbocharger 4.

493 – AL ETC3 CutIn Failure

ZKP-Number: 18.004.203

Cause	Corrective action
ETC 3 failed to cut in.	▶ Check control valve on turbocharger 3.

500 – AL Wiring POM Starter 1

ZKP-Number: 14.500.900

Cause	Corrective action
A wiring fault was detected in the connection of starter 1 of the CPM. The root cause might be a missing consumer, a wire break or a short circuit.	▶ Check connection between POM and starter.

501 – AL Wiring POM Starter 2

ZKP-Number: 14.500.901

Cause	Corrective action
A wiring fault was detected in the connection of starter 2 of the CPM. The root cause might be a missing consumer, a wire break or a short circuit.	▶ Check connection between POM and starter.

502 – AL Open Load POM Alternator

ZKP-Number: 14.500.902

Cause	Corrective action
An open circuit was detected at the battery-charging generator connection of the POM.	▶ Check connection between POM and battery-charging generator.

503 – AL Battery Not Charging

ZKP-Number: 14.500.903

Cause	Corrective action
Battery-charging generator does not charge the battery.	▶ Check battery-charging generator and cabling.

504 – AL CAN POM Node Lost

ZKP-Number: 14.500.904

Cause	Corrective action
POM missing on CAN bus.	▶ Check connection and POM.

506 – AL Low Starter Voltage

ZKP-Number: 14.500.906

Cause	Corrective action
Battery voltage too low for starting sequence.	▶ Check starter battery and cabling.

507 – AL POM Error

ZKP-Number: 14.500.907

Cause	Corrective action
A general POM error occurred.	▶ Replace POM.

508 – AL Wrong POM-ID

ZKP-Number: 14.500.908

Cause	Corrective action
POM transmits a different ID No. than expected.	▶ Check POM wiring harness.

510 – AL Override applied

ZKP-Number: 27.002.010

Cause	Corrective action
Override was activated.	▶ Deactivate Override pushbutton.

515 – AL Starter Not Engaged

ZKP-Number: 21.090.926

Cause	Corrective action
Starter on CPM / POM could not be engaged. The starting sequence will be terminated when the number of automatic start attempts defined in PR 2.1090.134 is exhausted. Check CPM, starter and cabling.	<ol style="list-style-type: none"> 1. Repeat starting attempt 2. Check CPM, starter and cabling.

519 – Oilniveau Calibration Error

ZKP-Number: 10.158.921

Cause	Corrective action
Error when writing the calibration value to flash memory or level sensor defect.	<ol style="list-style-type: none"> 1. Check sensor and cabling, replace as necessary. 2. Contact Service.

521 – SS P-Lube Oil Mid Val

ZKP-Number: 20.480.289

Limit value 1

Cause	Corrective action
Average oil pressure value from three sources is too low.	▶ Check oil level, top up as necessary.

523 – SS T-Coolant Red Mid Val

ZKP-Number: 20.480.189

Limit value 2

Cause	Corrective action
Average coolant temperature value from three sources is too high.	▶ Reduce power.

524 – SS Engine Overspeed Mid Val

ZKP-Number: 20.480.089

Limit value 2

Cause	Corrective action
Average engine overspeed value from three sources is too high.	1. Acknowledge alarm. 2. Attempt to restart engine.

525 – SD P-Lube Oil (R2)

ZKP-Number: 18.004.638

Cause	Corrective action
Redundant lube oil pressure sensor faulty; short circuit or wire break.	▶ Check sensor and cabling, replace as necessary.

526 – SD T-Coolant (R2)

ZKP-Number: 18.004.639

Cause	Corrective action
Redundant coolant temperature sensor faulty; short circuit or wire break.	▶ Check sensor and cabling, replace as necessary.

527 – D EngineSpd. Sensor Deviation

ZKP-Number: 10.480.093

Cause	Corrective action
Maximum deviation of speed sensors	1. Check cabling of speed sensors. 2. Check for additional messages. 3. Contact Service.

528 – SD Engine Speed 3rd Sensor

ZKP-Number: 12.500.102

Cause	Corrective action
Redundant crankshaft speed sensor faulty; short circuit or wire break.	▶ Check sensor and cabling, replace as necessary.

529 – SS T-Coolant Red2

ZKP-Number: 20.480.195

Limit value 2

Cause	Corrective action
Second redundant coolant temperature too high.	▶ Check coolant circuit.

530 – SS P-Lube Oil Red2

ZKP-Number: 20.480.295

Limit value 2

Cause	Corrective action
Second redundant lube-oil pressure too high.	▶ Check oil level, top up as necessary.

543 – AL Multiple FDH Slaves

ZKP-Number: 20.555.005

Cause	Corrective action
There is more than one unit activated as backup medium for FDH.	▶ Contact Service.

544 – AL Configuration Changed

ZKP-Number: 20.555.003

Cause	Corrective action
This alarm is activated if the system configuration was changed, e.g. due to an exchange of the ECU or SAM.	▶ This alarm remains active until either the process is made undone or data have been transferred due to an active maintenance job. The alarm will then be cleared automatically.

549 – AL Power Cut-Off detected

ZKP-Number: 27.001.952

This is an alarm from the emergency stop counting feature.

Cause	Corrective action
The ECU supply voltage was switched off while the engine was running. This may lead to excessive pressure in the HP fuel system which might cause damage to the engine.	▶ Instruct operators to disconnect power supply only when the engine is at standstill.

550 – SS Engine Overspeed Red2

ZKP-Number: 20.480.095

Limit value 2

Cause	Corrective action
Redundant engine overspeed.	<ol style="list-style-type: none"> 1. Acknowledge alarm. 2. Attempt to restart engine.

551 – SS Engine Overspeed Camshaft

ZKP-Number: 22.510.933

Limit value 2

Cause	Corrective action
Camshaft overspeed.	<ol style="list-style-type: none"> 1. Acknowledge alarm. 2. Attempt to restart engine.

555 – AL Call MTU Field Service

ZKP-Number: 20.555.001

Cause	Corrective action
<p>This alarm is activated if the ECU feature Field Data Handling (FDH) has carried out a maintenance job which led to a change of the engine parameters.</p> <p>This alarm will stay active even after switching the system off and on again until a valid activation code has been entered via the display and key control of the SAM. This activation code can be requested via internet according to a special procedure.</p>	<ul style="list-style-type: none"> ▶ Request activation code via internet.

576 – AL ESCM Override

ZKP-Number: 11.075.083

Cause	Corrective action
Corrected MCR or DBR/MCR curve was exceeded. Engine overload!	<ul style="list-style-type: none"> ▶ Reduce power.

577 – SD T-Lube Oil Pan

ZKP-Number: 10.137.900

Cause	Corrective action
Temperature sensor in oil pan faulty; short circuit or wire break.	<ul style="list-style-type: none"> ▶ Check sensor and cabling, replace as necessary.

578 – AL L1 T-Lube Oil Pan

ZKP-Number: 20.137.921

Limit value 1

Cause	Corrective action
L1 T-Lube Oil Pan has violated limit value 1.	▶

579 – AL MD CAN Request Idle Speed

ZKP-Number: 21.063.511

Cause	Corrective action
MD forced idle demand => node failure (node 3,4 or 5)	▶

580 – AL MD CAN Speed Limitation

ZKP-Number: 21.063.513

Cause	Corrective action
MD speed limitation demand => node failure (node 3,4 or 5)	▶

581 – AL MD CAN Stop

ZKP-Number: 21.063.515

Cause	Corrective action
MD CAN stop demand => node failure (node 3,4 or 5)	▶

6 Task Descriptions

6.1 Engine

6.1.1 Engine – Barring manually

Preconditions

- Engine shut down and starting disabled.

Special tools

Designation / Use	Part No.	Qty.
Barring gear	F6555766	1
Ratchet head with extension	F30006212	1



Unguarded rotating and moving engine components.

Risk of serious injury — danger to life!

- Before barring the engine, ensure that nobody is in the danger zone.

Barring the engine manually

1. Remove guard plate.
2. Engage barring tool (2) with ring gear (3) and mount on flywheel housing.
3. Set ratchet (1) onto barring tool (2).
4. Rotate crankshaft in engine direction of rotation. Apart from the normal compression resistance, there should be no abnormal resistance.
5. For barring-tool removal follow reverse sequence of working steps.

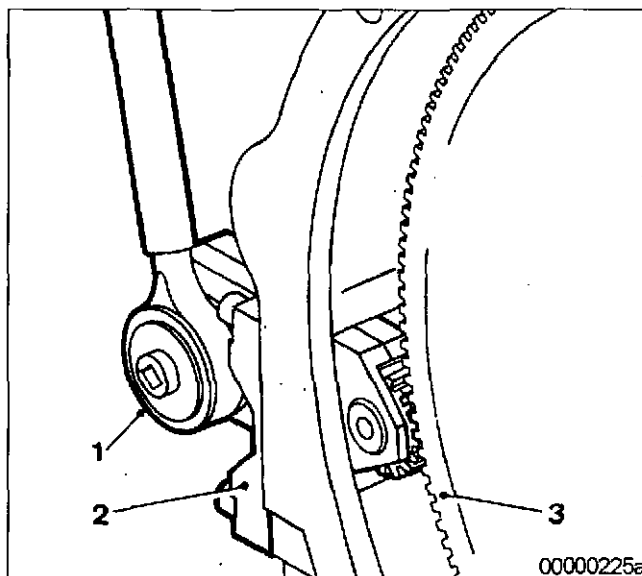

6.1.2 Engine – Barring with starting system



DANGER

Unguarded rotating and moving engine components.

Risk of serious injury - danger to life!

- Before barring or starting the engine, ensure that nobody is in the danger zone.
- After working on the engine, check that all protective devices have been reinstalled and all tools removed from the engine.

Engine – Barring with starting system

1. Release latch of connector X4.
2. Disconnect connector from engine governor.
3. Bar engine in unloaded condition: Press START button.
4. Let the crankshaft rotate until oil pressure is indicated.
5. Engine start is automatically interrupted when specified starting period is expired. If necessary, re-start the engine after approx. 20 seconds.
6. Connect connector X4 to engine governor and latch in position.

6.2 Cylinder Liner

6.2.1 Cylinder liner – Endoscopic examination

Preconditions

- Engine is stopped and starting disabled.

Special tools

Designation / Use	Part No.	Qty.
Rigid endoscope	Y20097353	1

Preparatory steps

1. Remove cylinder-head cover (→ Page 145).
2. Remove injector (→ Page 147).

Positioning crankshaft at BDC

1. Using barring device, turn crankshaft until crankpin of the cylinder to be tested has reached BDC.
2. Insert endoscope into cylinder liner through injector seat.

Cylinder liner - Endoscopic examination

Findings	Task
<ul style="list-style-type: none"> • Thin carbon coating on carbon scraper ring • Slight localized additive deposits at top edge • Localized smooth areas at lower edge • Carbon deposits on entire circumference between top piston ring and lower edge of carbon scraper ring • First signs of marks left by top piston ring • Bright mark on entire circumference • Faultless, even honing pattern • First signs of marks left by lower cooling bores • Running pattern seems darker 	No actions required
<ul style="list-style-type: none"> • Darker areas of even or varying color intensity • Beginning and end of the discoloration are not sharply defined and do not cover the entire stroke area • Dark areas in the upper section of the cooling bore, remaining circumference cannot be faulted • Piston rings cannot be faulted 	Further endoscopic examination required as part of maintenance work
<ul style="list-style-type: none"> • On the entire circumference not only bright discoloration (not critical for operation) clearly visible darker stripes that begin at the top piston ring • Heat discoloration in the direction of stroke and honing pattern damage • Heat discoloration of piston rings 	Cylinder liner must be replaced; Service must be contacted

1. Compile endoscopy report using the table.
2. Use technical terms for description of the liner surface (→ Page 136).
3. Depending on findings:
 - Do not take any action or
 - carry out further endoscopic examination as part of maintenance work or
 - contact Service: cylinder liner must be replaced.

Final steps

1. Install injector (→ Page 147).
2. Install cylinder-head cover (→ Page 145).

6.2.2 Instructions and comments on endoscopic and visual examination of cylinder liners

Terms used for endoscopic examination

Use the terms listed below to describe the condition of the cylinder-liner surface in the endoscopic examination report.

Minor dirt scores	Light scoring can take place during the assembly of a new engine (honing products, particles, broken-off burrs). Removed cylinders clearly show such scoring on the running surface under endoscope magnification. Cannot be felt with the fingernail. Findings not critical.
Single scores	Clearly visible scores from hard particles. They usually start in the TDC area and cross through the hone pattern in the direction of stroke. Findings not critical.
Scored area	These areas consist of scores of different length and depth next to one another. In most cases, they are found at the 6-o'clock and 12-o'clock positions (inlet/exhaust) along the transverse engine axis. Findings not critical.
Smoothened area	Smoothened areas are on the running surface but almost the whole honing pattern is still visible. Smoothened areas appear brighter and more brilliant than the surrounding running surface. Findings not critical.
Polished area	Polished areas are on the running surface and show local removal of the honing pattern. Grooves from honing process are not visible any more.
Discoloration	This is caused by oxidation (surface discoloration through oil or fuel) and temperature differences around the liner. It appears rather darker within the honed structure in contrast to the bright metallic running surface. The honing pattern is undisturbed. Discolorations extend in stroke direction and may be interrupted. Findings not critical.
Corrosion fields / spots	Corrosion fields / spots result from water (condensed water) with the valves in the overlap (open) position. They are clearly visible due to the dark color of the honing groove bottom. This corrosion is not critical unless there are corrosion pittings.
Black lines	Black lines are a step towards heat discoloration. They are visible as a clear discoloration from TDC to BDC in the running surface and the start of localized damage to the honing pattern. Cylinders with a number of black lines around the running surface have limited service life and should be replaced.
Discolorations (Heat)	These are caused by a disturbance in the liner / ring tribosystem. Usually they run over the whole ring-travel area (TDC/BDC), starting at the first TDC-ring and becoming more visible from the second TDC-ring onwards and less pronounced from TDC-ring 1. The honing pattern is usually no longer visible and displays a clearly defined (straight) edge to the undisturbed surface. The damaged surface is usually discolored. The circumferential length varies. Liners with heat discoloration starting in the TDC-ring 1 have to be replaced.
Seizures, Seizure marks	Irregular circumference lengths and depths. Can be caused by either the piston skirt or the piston crown. Material deposits on the liner (smear), heavy discoloration. Severe, visible scoring. Replace liner.

Evaluation of findings and further measures

The findings in the start phase of oxidation discoloration and heat discoloration are similar. Thorough investigation and compliance with the above evaluation criteria allows a definite evaluation. To avoid unnecessary disassembly work, it is recommended that another inspection be carried out after further operation of the engine.

6.3 Crankcase Breather

6.3.1 Crankcase breather – Oil separator replacement, diaphragm check and replacement

Preconditions

- Engine is stopped and starting disabled.

Special tools

Designation / Use	Part No.	Qty.
Torque wrench 6-50 Nm	F30027336	1
Ratchet adapter	F30027340	1

Material

Designation / Use	Part No.	Qty.
Engine oil		

Spare parts

Designation / Use	Part No.	Qty.
Filter element		
Diaphragm		
Seal		



Hot oil.
 Oil can contain combustion residues which are harmful to health.
Risk of injury and poisoning!

- Wear protective clothing, gloves, and goggles / safety mask.
- Avoid contact with skin.
- Do not inhale oil vapor.

Replacing oil separator

1. Remove cover (2) with O-ring (3).
2. Remove filter element (1) from housing (4).
3. Insert new filter element in housing (4).
4. Install cover (2) with new O-ring.
5. Tighten screws on cover (2) with torque wrench to the specified tightening torque.

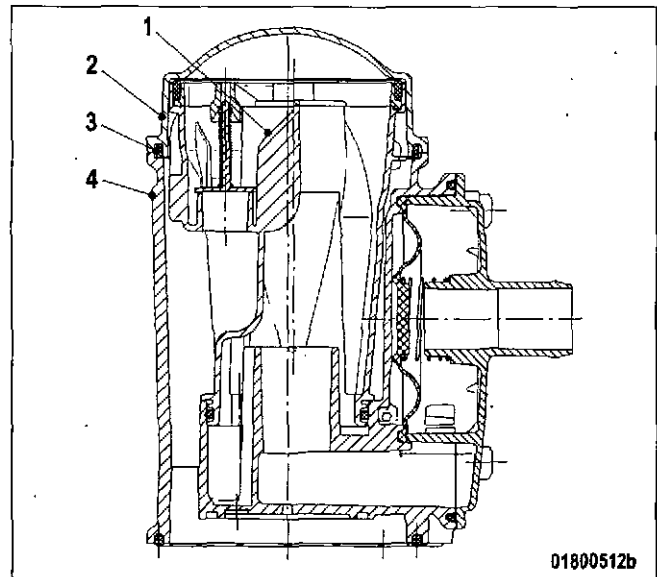

Name	Size	Type	Lubricant	Value/Standard
Screw		Tightening torque	Engine oil	10 Nm -2 Nm

6. Replace further oil separator elements in the same way.

Checking diaphragm

1. Remove cover (4).
2. Take off spring (5), seal (2) and diaphragm (3).
3. Check diaphragm (3) for damage, fit new diaphragm if used one is damaged.
4. Install diaphragm (3) on housing (1).
5. Install new seal (2) and spring (5) together with cover (4).
6. Tighten screws on cover (4) with torque wrench to the specified tightening torque.

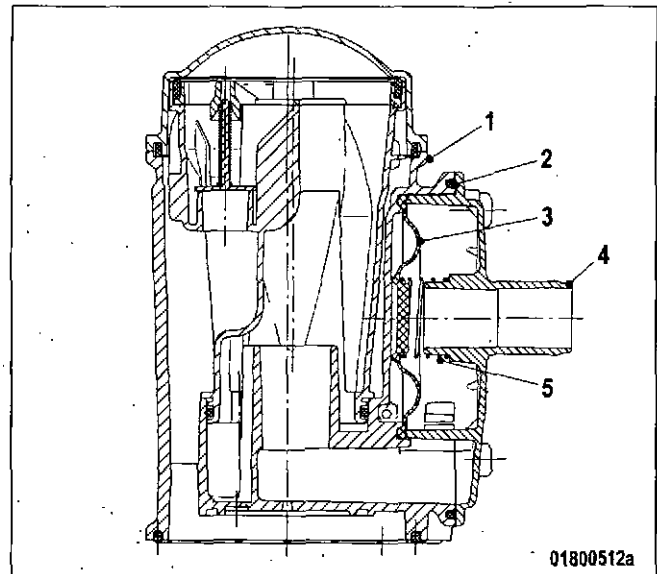

Name	Size	Type	Lubricant	Value/Standard
Screw		Tightening torque	Engine oil	10 Nm -2 Nm

7. Check diaphragms in further oil separators in the same way.

6.4 Valve Gear

6.4.1 Valve gear – Lubrication

Preconditions

- Engine is stopped and starting disabled.

Material

Designation / Use	Part No.	Qty.
Engine oil		

Valve gear – Lubrication

1. Remove cylinder head covers (→ Page 145).
2. Fill oil chambers of valve bridges with oil.
3. Fill oil chambers of rocker arms and adjusting screws with oil.
4. Install cylinder head covers (→ Page 145).

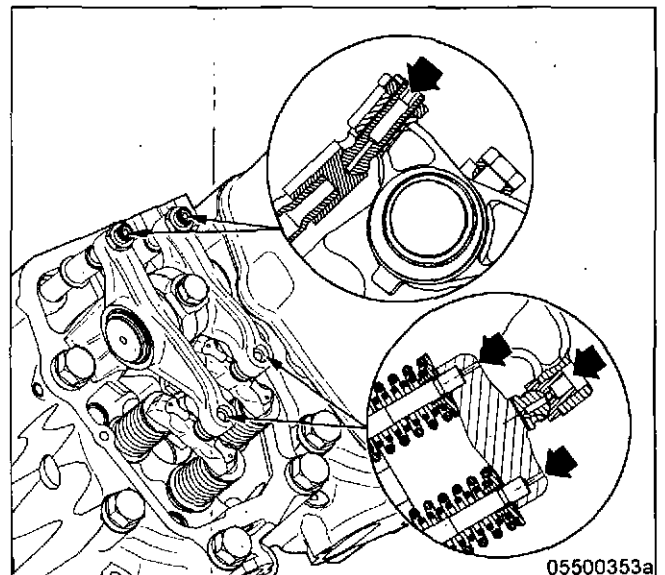

6.4.2 Valve clearance – Check and adjustment

Preconditions

- Engine is stopped and starting disabled.
- Engine coolant temperature is max. 40 °C.
- Valves are closed.

Special tools

Designation / Use	Part No.	Qty.
Feeler gauge	Y20010128	1
Torque wrench, 60-320 Nm	F30047446	1
Ring socket, 24 mm	F30039526	1

Preparatory steps

1. Remove cylinder head cover (→ Page 145).
2. Install barring tool (→ Page 131).
3. The "OT" marking (1) (if provided) on the flywheel must not be used.

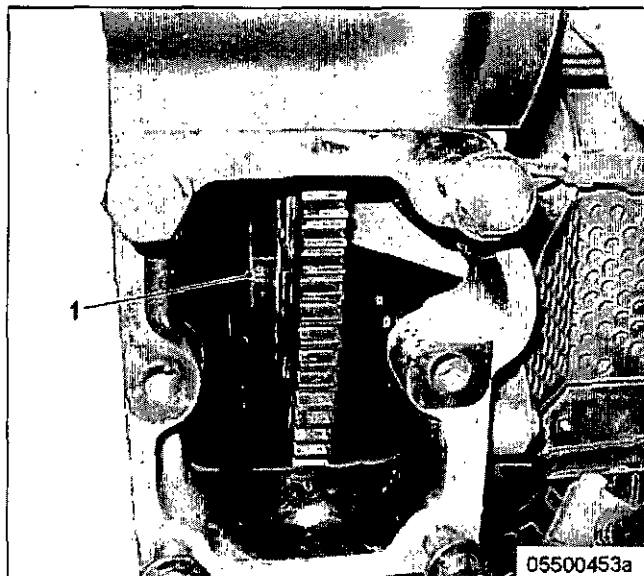

4. Rotate crankshaft with barring tool in engine direction of rotation until marking "OT-A1" and pointer are aligned.

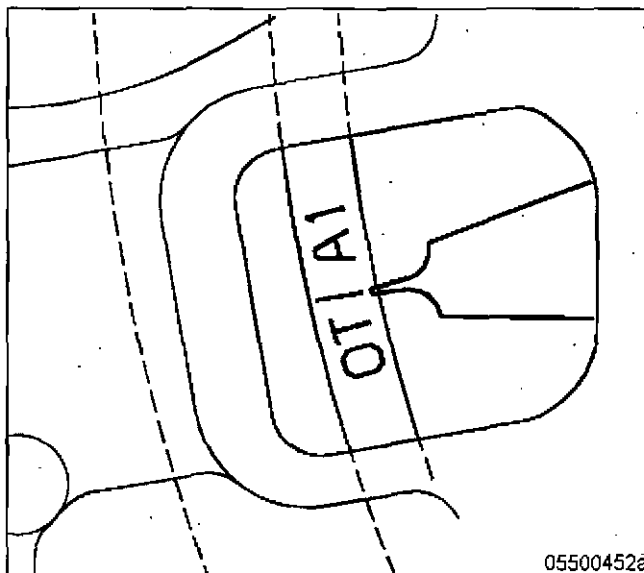

Diagram

- Two crankshaft positions
- Applicable to 8V engines

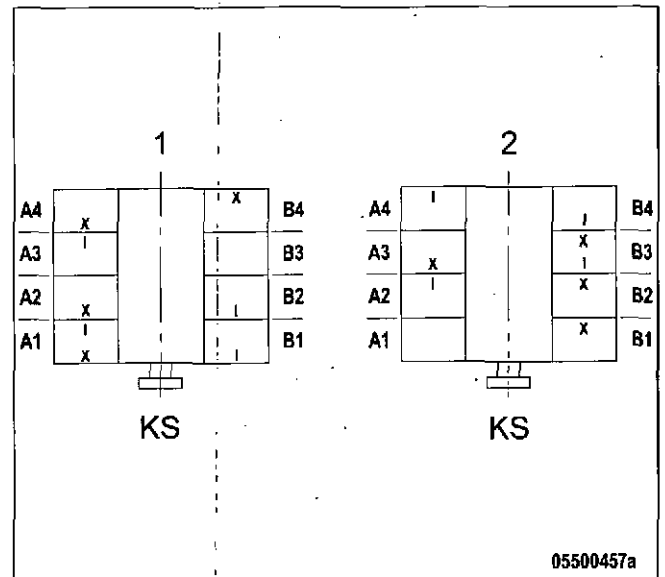

- 1 Cylinder A1 is in firing TDC
- 2 Cylinder A1 is in overlap TDC
- I Inlet valve
- X Exhaust valve

Diagram

- Two crankshaft positions
- Applicable to 12V engines

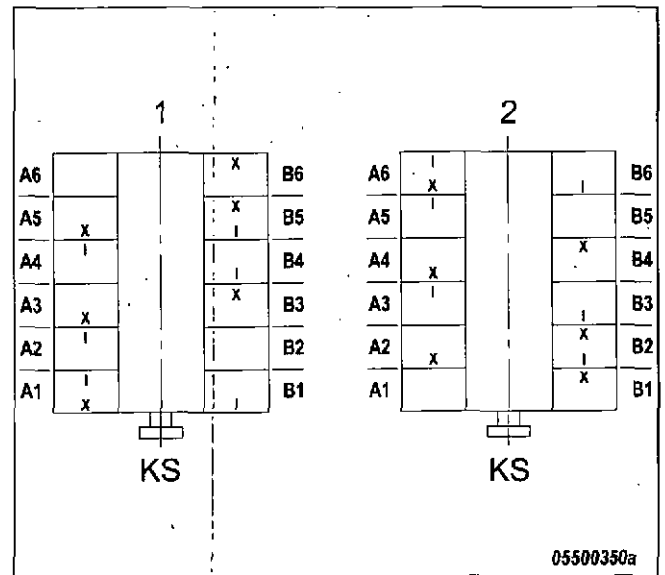

- 1 Cylinder A1 is in firing TDC
- 2 Cylinder A1 is in overlap TDC
- I Inlet valve
- X Exhaust valve

Diagram

- Two crankshaft positions
- Applicable to 16V engines

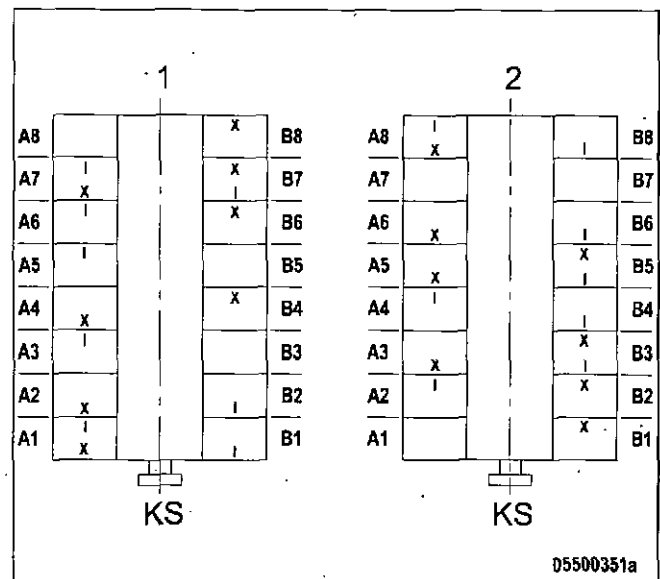

- 1 Cylinder A1 is in firing TDC
 - 2 Cylinder A1 is in overlap TDC
- I Inlet valve
X Exhaust valve

Diagram

- Two crankshaft positions
- Applicable to 20V engines

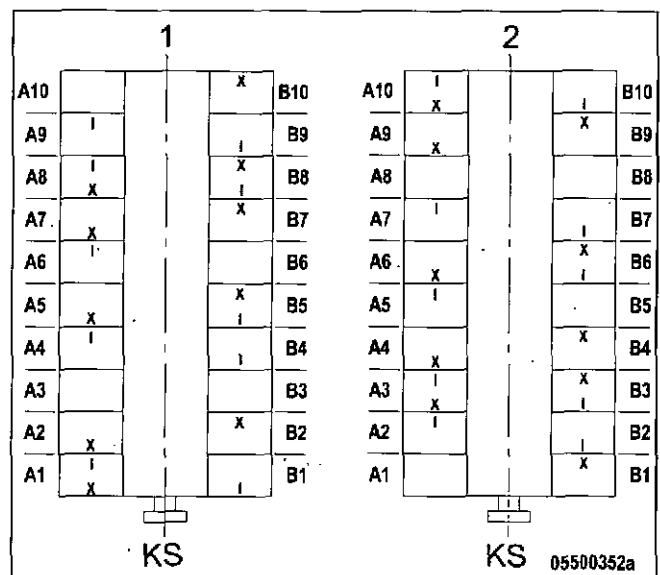

- 1 Cylinder A1 is in firing TDC
 - 2 Cylinder A1 is in overlap TDC
- I Inlet valve
X Exhaust valve

Checking valve clearance at two crankshaft positions

1. Check TDC position of piston in cylinder A1:
 - If the rocker arms are unloaded on cylinder A1, the piston is in firing TDC.
 - If the rocker arms are loaded on cylinder A1, the piston is in overlap TDC.
2. Check valve clearance with cold engine:
 - Inlet valves (long rocker arm) = 0.2 mm
 - Exhaust valves (short rocker arm) = 0.5 mm
3. Check all valve clearances at two crankshaft positions (firing and overlap TDC for cylinder A1) as per diagram.
4. Use feeler gauge to determine the distance between valve bridge and rocker arm.
5. If the deviation from the reference value exceeds 0.1 mm, adjust valve clearance.

Adjusting valve clearance

1. Release locknut (1).
2. Insert feeler gauge between valve bridge and rocker arm.
3. Using Allen key, set adjusting screw (2) so that the specified valve clearance is provided.
4. Feeler gauge must just pass through the gap.
5. Tighten locknut (1) to 90 ± 9 Nm, holding adjusting screw (2) firm.
6. Replace or rectify adjusting screws and/or locknuts which do not move freely.
7. Check valve clearance.

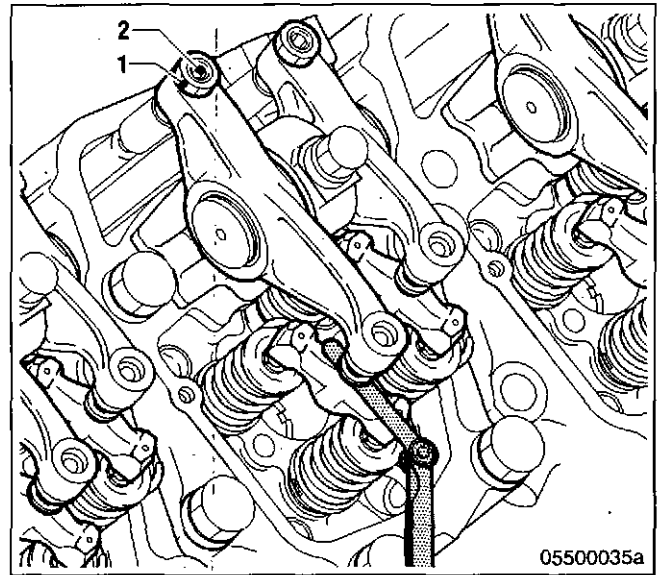
**Final steps**

1. Remove barring tool (→ Page 131).
2. Install cylinder head cover (→ Page 145).

6.4.3 Cylinder head cover – Removal and installation

Preconditions

- Engine is stopped and starting disabled.

Spare parts

Designation / Use	Part No.	Qty.
Gasket		

Cylinder head cover removal

1. Clean very dirty cylinder head covers prior to removal.
2. Remove screws.
3. Remove cylinder head cover with gasket from cylinder head.

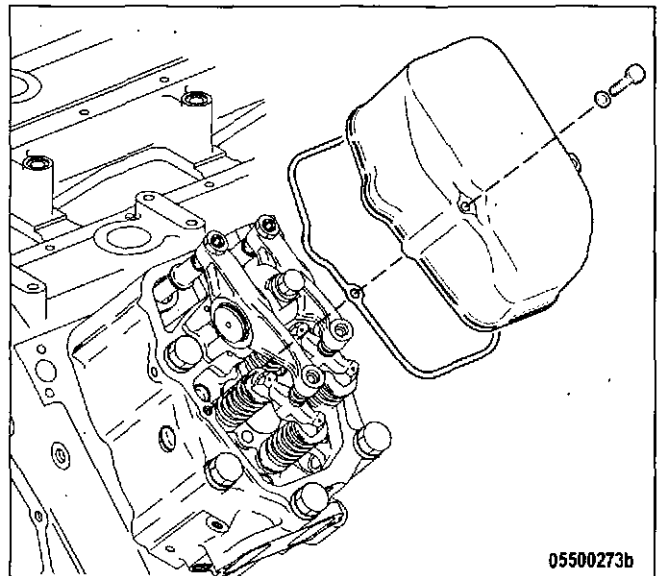

Cylinder head cover installation

1. Clean mating faces.
2. Check condition of gasket, replace if necessary.
3. Place gasket and cylinder head cover on cylinder head.
4. Install cylinder head cover.

6.5 Fuel Injector

6.5.1 Injector – Replacement

Spare parts

Designation / Use	Part No.	Qty.
Injector		

Remove injector and install new one (→ Page 147).

6.5.2 Injector – Removal and Installation

Preconditions

- Engine is stopped and starting disabled.

Special tools

Designation / Use	Part No.	Qty.
Installation/removal tool for injector	F6789889	1
Milling cutter	F30452739	1
Slotted nut driver	F30452578	1
Torque wrench 0.5-5 Nm	0015384230	1
Torque wrench 10-60 Nm	F30510423	1
Torque wrench 60-320 Nm	F30047446	1

Material

Designation / Use	Part No.	Qty.
Assembly paste (Optimoly Paste White T)	40477	1
Grease (Kluthe Hakuform 30-10/Emulgier)	X00029933	1
Engine oil		



WARNING

Fuels are combustible.

Risk of fire and explosion!

- Avoid open flames, electrical sparks and ignition sources.
- Do not smoke.

Preparatory steps

1. Shut off fuel supply to engine.
2. Remove cylinder head cover (→ Page 145).

Injector removal

1. Withdraw cable connector on injector.

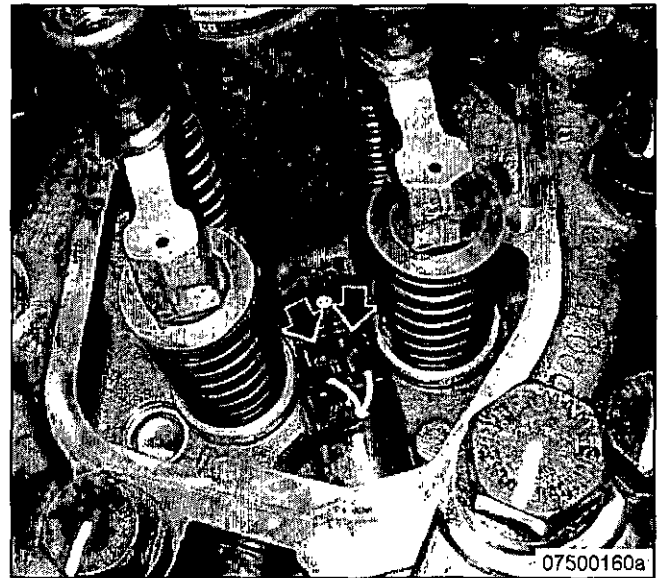

2. Remove HP fuel line (4).

3. Remove return line (5).

Note: The injector accumulator will be emptied when removing the adapter.

4. Remove adapter (3).

5. Remove screw (2) and take off hold-down clamp (1).

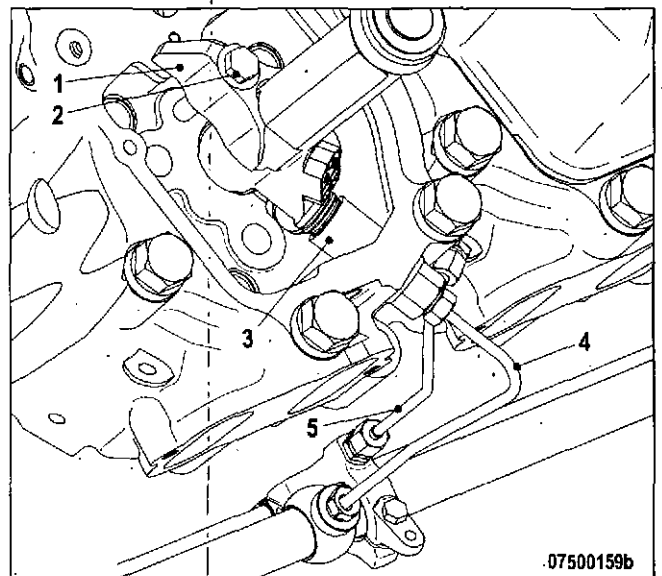

6. Install installation/removal tool on cylinder head.

7. Remove injector with installation/removal tool.

8. Remove installation/removal tool.

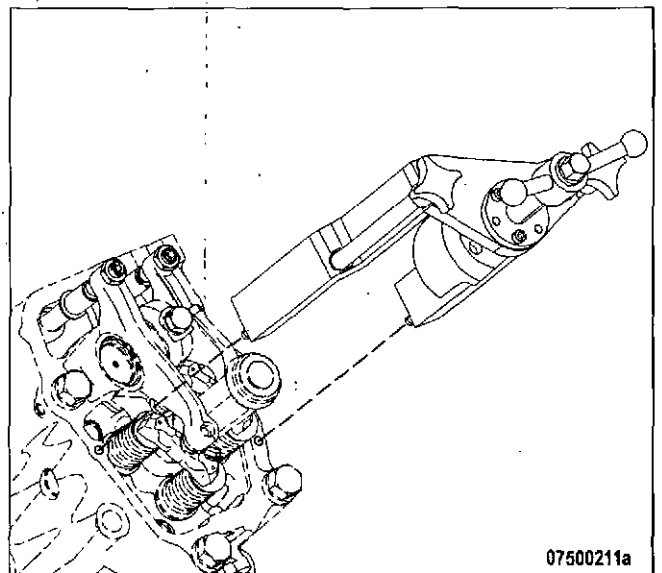

9. Remove sealing ring (1) from injector or use a self-made hook to take it out of the cylinder head.
10. Remove O-rings (2) and damping ring (3) from injector.
11. Cover all connections and bores, or seal with suitable plugs.

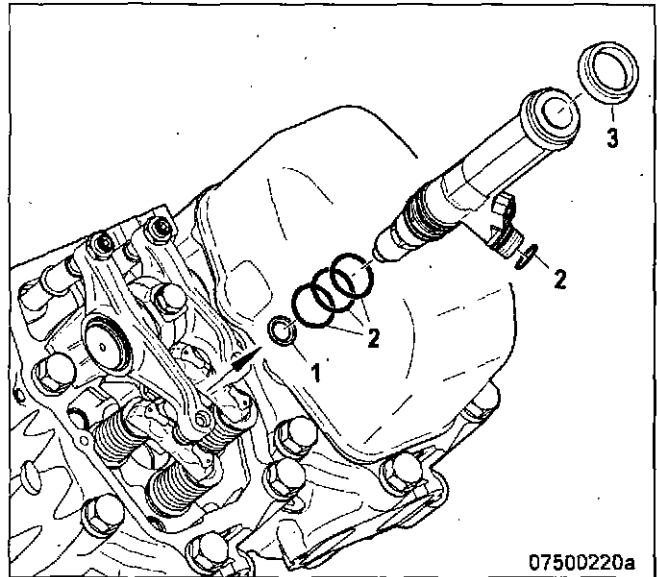

Injector installation

1. Remove plug before installing the injector. (Do not remove the plug from the HP line before installing the adapter.)
2. Coat injector with assembly paste at the seat of the nozzle clamping nut.
3. Fit new sealing ring with grease on injector, observe installation position of sealing ring.

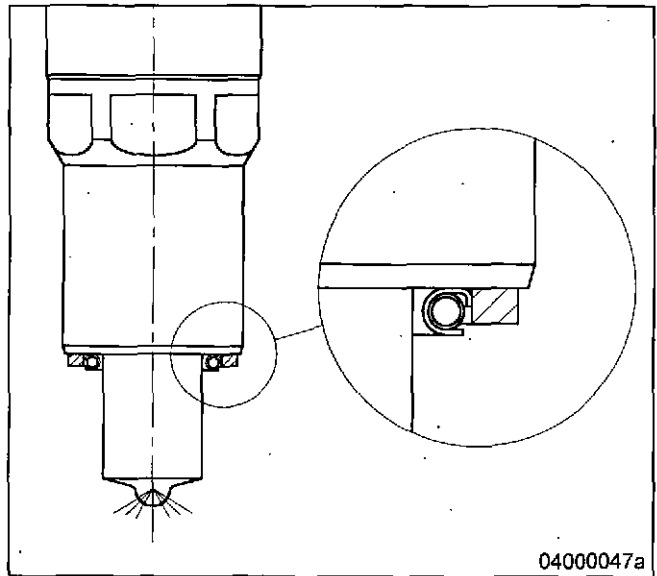

4. Fit new O-rings (2) and damping ring (3) onto the injector and coat with grease.

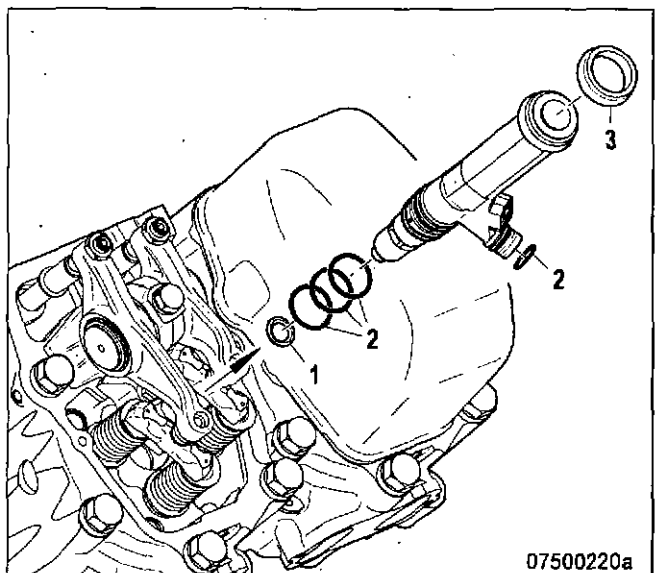

5. Clean sealing face on cylinder head and protective sleeve with milling cutter.
6. Insert injector into cylinder head, ensuring that the HP line adapter is correctly aligned.
7. Use installation/removal tool to press in injector.
8. Remove installation/removal tool.

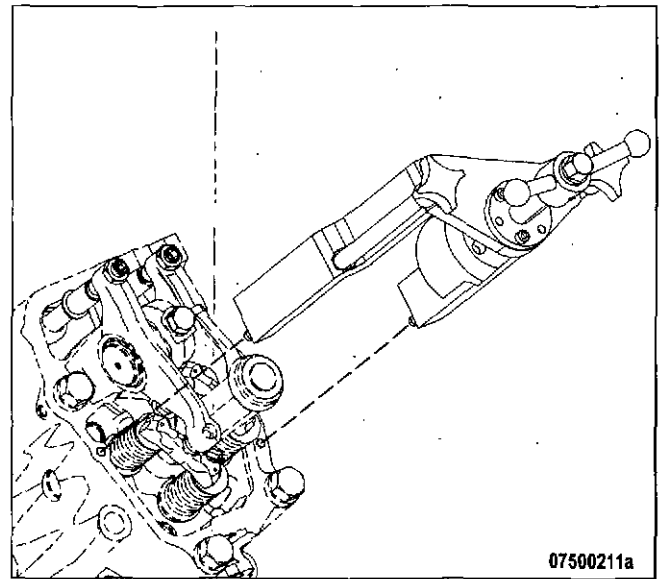

9. Coat screw head mating face (2) and thread with engine oil.
10. Position hold-down clamp (1) correctly and tighten screw (2) with torque wrench to the specified pretightening torque.

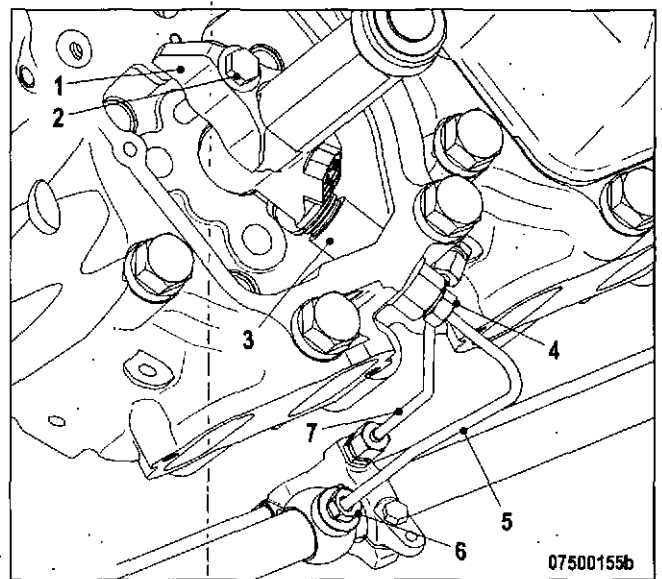

Name	Size	Type	Lubricant	Value/Standard
Screw	M12	Preload torque	Engine oil	5 Nm to 10 Nm

Note: Ensure special cleanness.

11. Coat thread and sealing cone of adapter (3) with engine oil.
12. Install adapter (3) and use torque wrench to tighten to the specified pretightening torque.

Name	Size	Type	Lubricant	Value/Standard
Adapter		Preload torque	Engine oil	5 Nm to 10 Nm

13. Tighten screw (2) with torque wrench to the specified tightening torque.

Name	Size	Type	Lubricant	Value/Standard
Screw	M12	Tightening torque		100 Nm + 10 Nm

14. Tighten adapter (3) with torque wrench to the specified tightening torque.

Name	Size	Type	Lubricant	Value/Standard
Adapter		Tightening torque		100 Nm + 10 Nm

15. Install return line (7).

Note: Ensure special cleanness.

16. Coat thread and sealing cone of HP line (5) with engine oil.

Note: HP lines are available in two versions (single-walled and jacketed) and must be tightened to different torques as described below.

17. Tighten single-walled HP line at adapter (4) and common rail (6) with torque wrench to the specified tightening torque.

Name	Size	Type	Lubricant	Value/Standard
Union nut / thrust screw		Tightening torque		30 Nm + 5 Nm

18. Tighten jacketed HP line at adapter (4) and common rail (6) with torque wrench to the specified tightening torque.

Name	Size	Type	Lubricant	Value/Standard
Union nut / thrust screw		Tightening torque		40 Nm + 5 Nm

19. Fit cable connector onto injector.

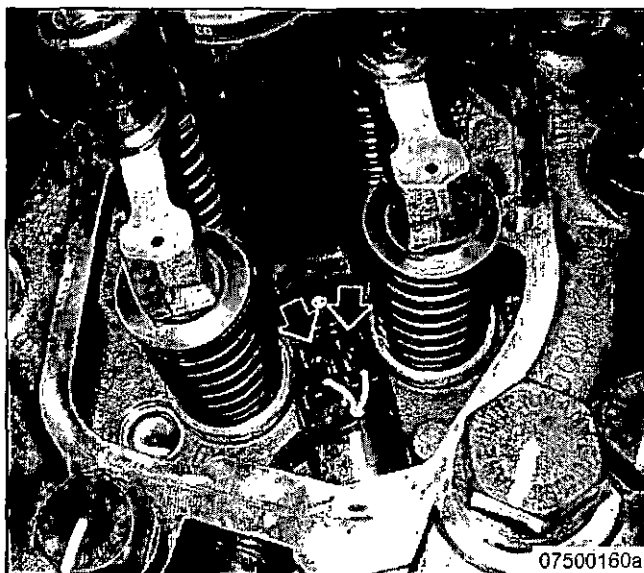

Final steps

1. Install cylinder head cover (→ Page 145).
2. Open fuel supply to engine.

6.6 Fuel System

6.6.1 Fuel system – Venting

Preconditions

- Engine is stopped and starting disabled.

Material

Designation / Use	Part No.	Qty.
Diesel fuel		



WARNING

Fuels are combustible.

Risk of fire and explosion!

- Avoid open flames, electrical sparks and ignition sources.
- Do not smoke.

Venting LP fuel system

1. Open vent plug (1).
2. Unlock fuel priming pump (2), screw out handle by turning it counterclockwise.
3. Operate the pump with the handle (2) until bubble-free fuel emerges from the vent plug (1).
4. Close vent plug (1).
5. Screw in handle, turning it clockwise.
6. Verify that fuel priming pump (2) is locked: handle must be tightened.

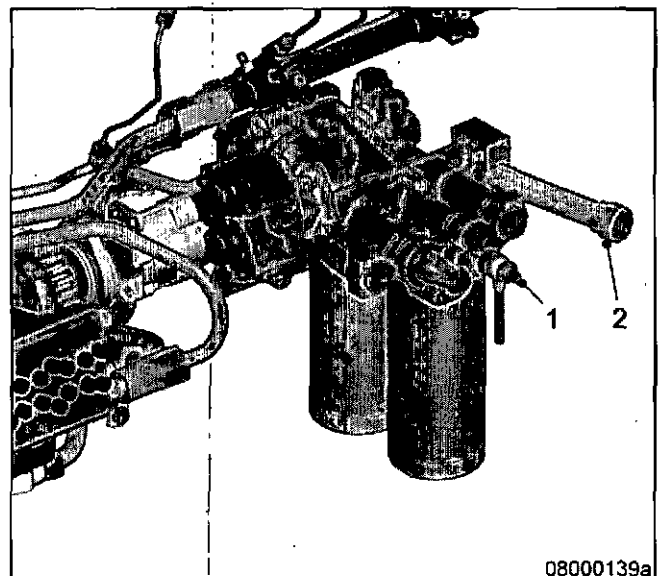

08000139a

6.7 Fuel Filter

6.7.1 Fuel filter – Replacement

Preconditions

- Engine is stopped and starting disabled.

Special tools

Designation / Use	Part No.	Qty.
Filter wrench	F30379104	1

Material

Designation / Use	Part No.	Qty.
Engine oil		

Spare parts

Designation / Use	Part No.	Qty.
Easy-change filter		



WARNING

Fuels are combustible.

Risk of fire and explosion!

- Avoid open flames, electrical sparks and ignition sources.
- Do not smoke.

Replacing the fuel filter

1. Remove easy-change filter using filter wrench.
2. Clean the sealing face of the filter head.
3. Slightly lubricate seal on the easy-change filter.
4. Screw on the easy-change filter by hand until the seal makes contact and tighten finger-tight.
5. Replace other easy-change filters in the same way.
6. Vent the fuel system (→ Page 152).

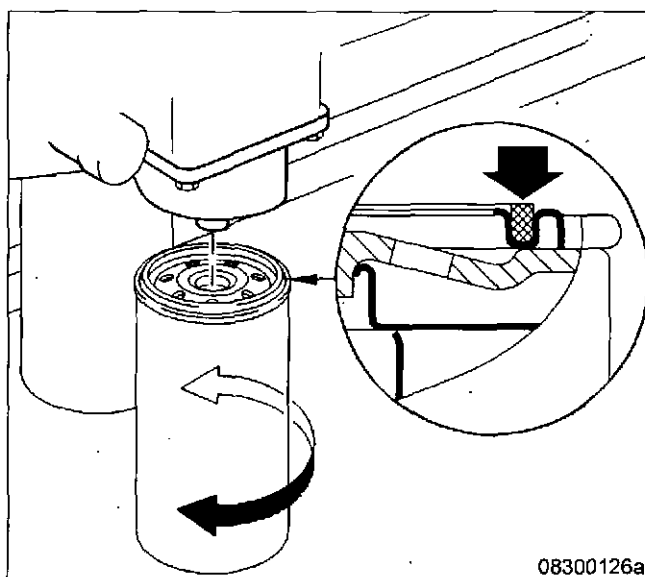

08300126a

6.7.2 Fuel prefilter cleaning

Preconditions

- Engine is stopped and starting disabled.

Material

Designation / Use	Part No.	Qty.
Diesel fuel		

Spare parts

Designation / Use	Part No.	Qty.
Sealing ring		



WARNING

Fuels are combustible.

Risk of fire and explosion!

- Avoid open flames, electrical sparks and ignition sources.
- Do not smoke.

Fuel prefilter cleaning

1. Shut off fuel supply.
2. Remove nuts from filter head.
3. Take off filter housing and drain fuel into appropriate container.
4. Remove filter-element securing nut and remove filter element by pulling it downwards.
5. Wash filter element in clean fuel using a smooth brush.
6. Wash filter housing with clean fuel.
7. Insert filter element into filter housing and secure with nut.
8. Place new sealing ring into groove in filter head.
9. Fit cover with seal and secure it with nuts crosswise.
10. Open fuel supply.

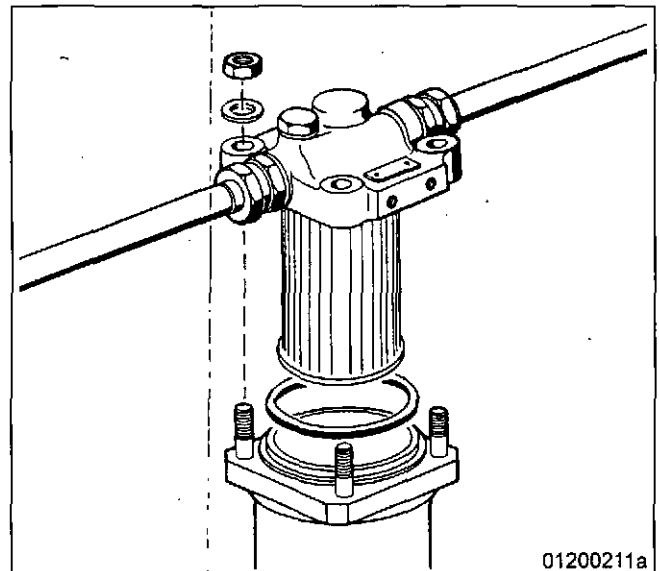

6.7.3 Fuel prefilter – differential pressure check and adjustment of gauge



Unguarded rotating and moving engine components.
Risk of serious injury – danger to life!
• Take special care when working on a running engine.



Engine noise above 85 dB (A).
Risk of damage to hearing!
• Wear ear protectors.

Setting adjustable pointer of differential pressure gauge

1. After installation of a new filter element, align adjustable pointer (2) with pressure-indicating pointer (3) of pressure gauge (1).
2. Verify that differential pressure is within the limit.

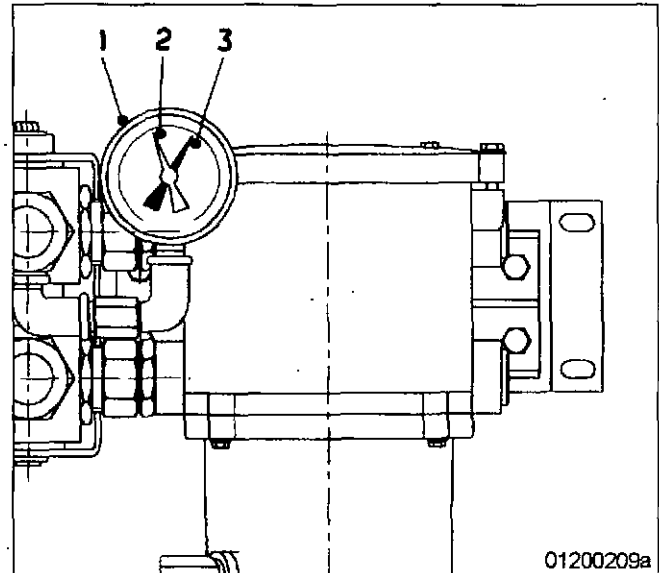

Fuel prefilter – checking differential pressure

1. With the engine running at full load or rated power, read off pressure at gauge (1).
2. If differential pressure as indicated between position of adjustable pointer (2) and pressure-indicating pointer (3) of pressure gauge is ≥ 0.3 bar, flush filter element of the cut-in filter (→ Page 158).

6.7.4 Fuel prefilter – Draining

Preconditions

- Engine is stopped and starting disabled.

Material

Designation / Use	Part No.	Qty.
Diesel fuel		

Spare parts

Designation / Use	Part No.	Qty.
Gasket		



WARNING

Fuels are combustible.

Risk of fire and explosion!

- Avoid open flames, electrical sparks and ignition sources.
- Do not smoke.

Fuel prefilter – Draining

1. Cut out the filter to be drained.

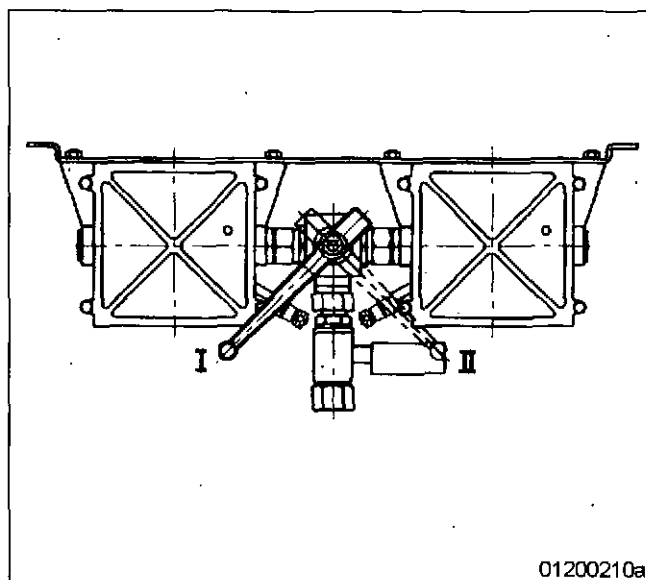

- I Left filter cut in
II Right filter cut in

2. Open vent plug (5) of the filter to be drained.
3. Unlock drain cock (6) by pressing toggle and open it.
4. Drain water and contaminants from the filter until pure fuel emerges.
5. Close drain cock (6).
6. Remove screws securing the cover and take off cover (2).
7. Fill filter housing with clean fuel.
8. Place new gasket in cover (2).
9. Fit cover with gasket and secure it with screws.
10. Cut the cut-out filter in again.
11. When fuel emerges from system, close vent plug (5).

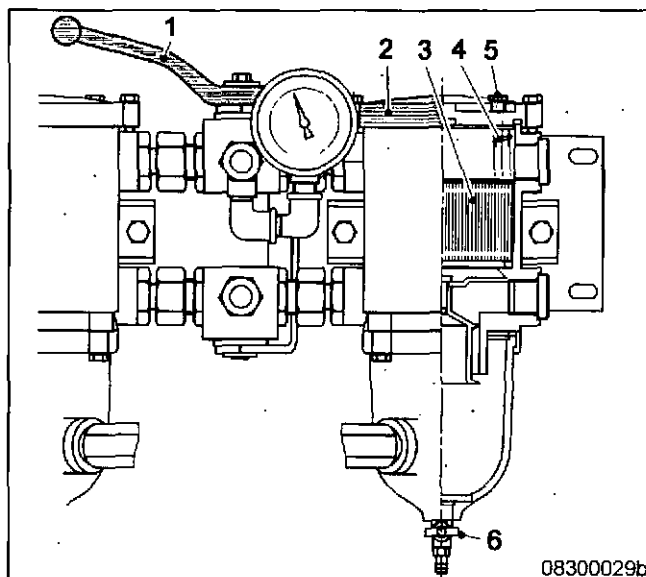

08300029b

6.7.5 Fuel prefilter – Flushing

Material

Designation / Use	Part No.	Qty.
Diesel fuel		

Spare parts

Designation / Use	Part No.	Qty.
Gasket		



Unguarded rotating and moving engine components.
Risk of serious injury – danger to life!
 • Take special care when working on a running engine.



Fuels are combustible.
Risk of fire and explosion!
 • Avoid open flames, electrical sparks and ignition sources.
 • Do not smoke.



Engine noise above 85 dB (A).
Risk of damage to hearing!
 • Wear ear protectors.

Fuel prefilter – Flushing

1. Cut out the contaminated filter.

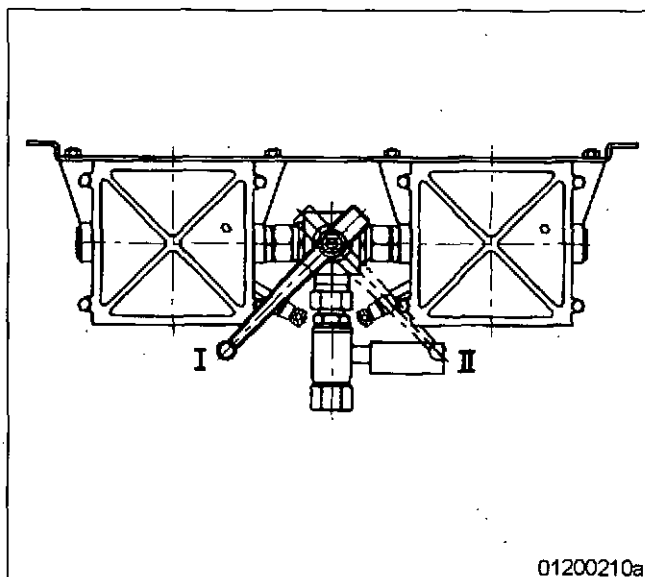

I Left filter cut in
II Right filter cut in

01200210a

2. Open vent plug (5) of the filter to be flushed.
3. Unlock drain cock (6) by pressing toggle, open it and drain fuel.

Result: Fuel flows from filtered side back to the unfiltered side, flushing the filter deposits downwards out of the filter.

4. Close vent plug (5) and drain cock (6).

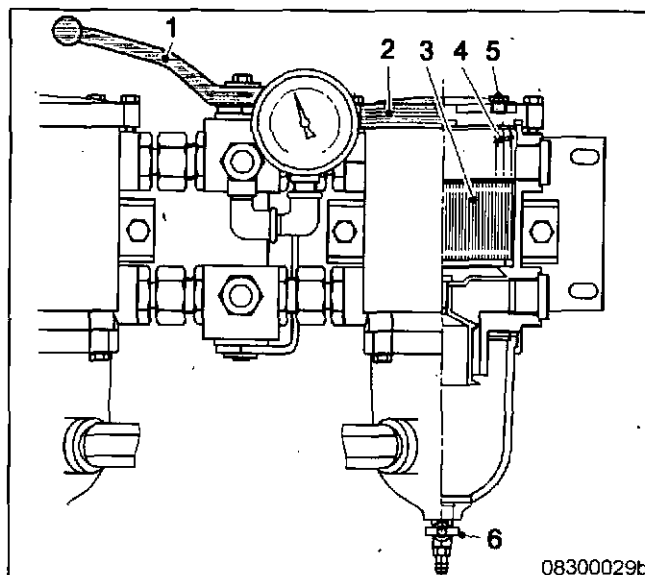

08300029b

Fuel prefilter – Filling with fuel

1. Stop engine (→ Page 59) and disable engine start.
2. Remove screws securing the cover and take off cover (2).
3. Fill filter housing with clean fuel.
4. Place new gasket in cover (2).
5. Fit cover with gasket and secure it with screws.
6. Check differential pressure (→ Page 155).

Result: If flushing did not lead to an improvement of the differential pressure, replace filter element (→ Page 160).

6.7.6 Fuel prefilter – filter element replacement

Preconditions

- Engine is stopped and starting disabled.

Material

Designation / Use	Part No.	Qty.
Diesel fuel		

Spare parts

Designation / Use	Part No.	Qty.
Filter element		
Gasket		



WARNING

Fuels are combustible.

Risk of fire and explosion!

- Avoid open flames, electrical sparks and ignition sources.
- Do not smoke.

Fuel prefilter – filter element replacement

1. Cut out the contaminated filter.

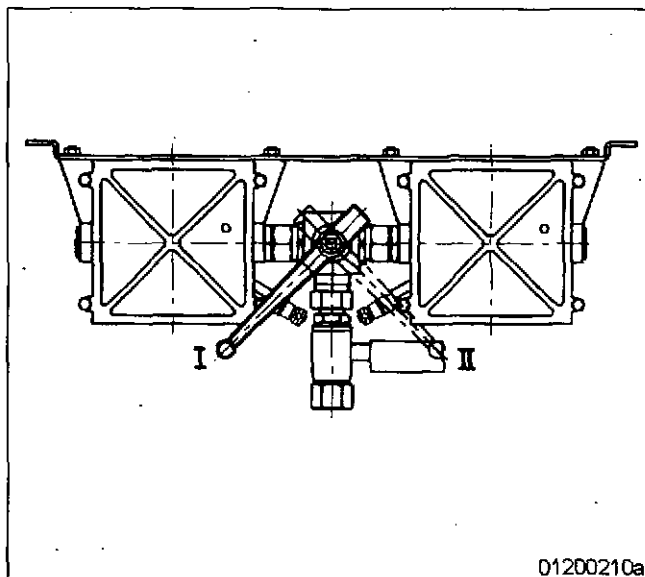

I Left filter cut in
II Right filter cut in

01200210a

2. Open vent plug (5) of the contaminated filter.
3. Unlock drain cock (6) by pressing toggle and open it.
4. Drain water and contaminants from the filter.
5. Close drain cock (6).
6. Remove screws securing the cover and take off cover (2).
7. Remove spring (4) and filter element (3).
8. Insert new filter element (3) and spring (4).
9. Fill filter housing with clean fuel.
10. Place new gasket in cover (2).
11. Fit cover with gasket and secure it with screws.
12. Cut the cut-out filter in again.
13. Close vent plug (5) when fuel emerges.
14. Align adjustable pointer of differential pressure gauge with pressure-indicating pointer.
(→ Page 155).

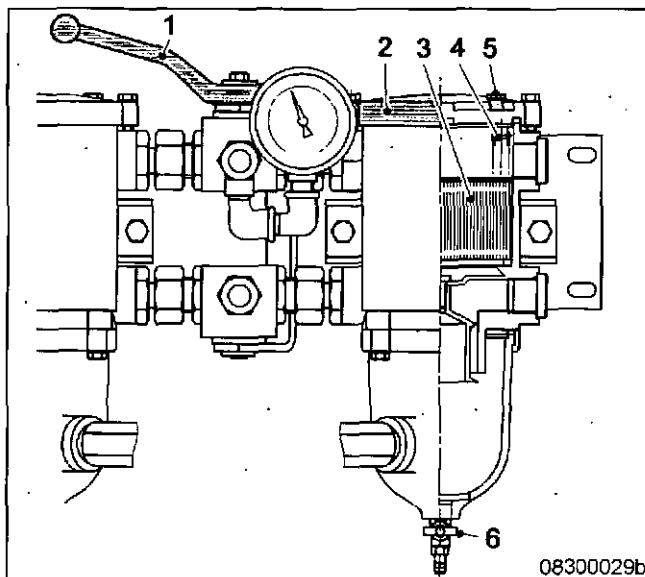

08300029b

6.8 Charge-Air Cooling

6.8.1 Intercooler – Checking condensate drains for coolant discharge and obstructions



DANGER

Unguarded rotating and moving engine components.
Risk of serious injury – danger to life!
 • Take special care when working on a running engine.



WARNING

Engine noise above 85 dB (A).
Risk of damage to hearing!
 • Wear ear protectors.



WARNING

Compressed air.
Risk of injury!
 • Do not direct compressed-air jet at persons.
 • Wear protective goggles / safety mask and ear protectors.

Intercooler – Checking condensate drains for coolant discharge and obstructions

1. With the engine running, verify that air emerges from the condensate drain(s) at driving end, left and right engine side. If no air emerges:
2. Clean drain bore(s) and blow out with compressed air.
3. If a large amount of coolant is continuously discharged, the intercooler is leaking. Contact Service.

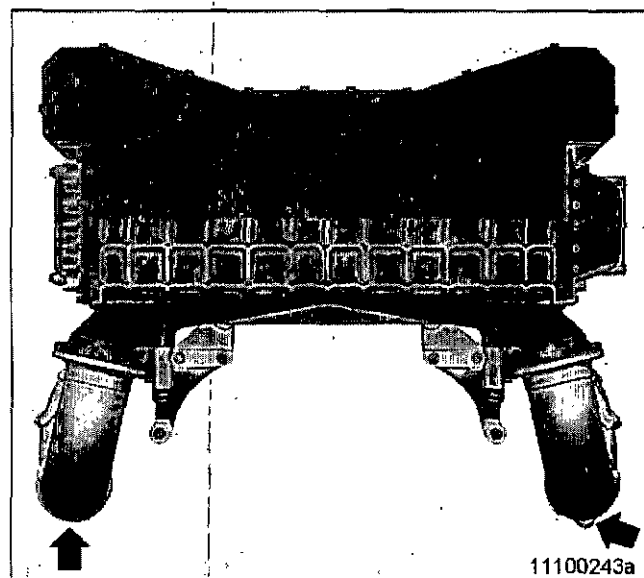

Emergency measures prior to engine start with a leaking intercooler

1. Remove injectors (→ Page 147).
2. Bar engine manually (→ Page 131).
3. Bar engine with starting system to blow out combustion chambers (→ Page 132).
4. Install injectors (→ Page 147).

6.9 Air Filter

6.9.1 Air filter replacement

Spare parts

Designation / Use	Part No.	Qty.
Air filter		

Remove air filter and install new one (→ Page 165).

Reset signal ring of service indicator (→ Page 166).

6.9.2 Air filter – Check

Spare parts

Designation / Use	Part No.	Qty.
Air filter		

Air filter – Check

1. Check entire circumference of air filter for damage.
2. Fit new air filter if damaged (→ Page 165).

6.9.3 Air filter – Removal and installation

Preconditions

- Engine is stopped and starting disabled.

Air filter – Removal and installation

1. Loosen clamp (2).
2. Remove air filter (3) and clamp (2) from flange of intake housing (1).
3. Verify that there are no objects in the flange of the intake housing (1) and clean it.
4. Place new air filter (3) with clamp (2) onto intake housing (1).
5. Tighten clamp (2).

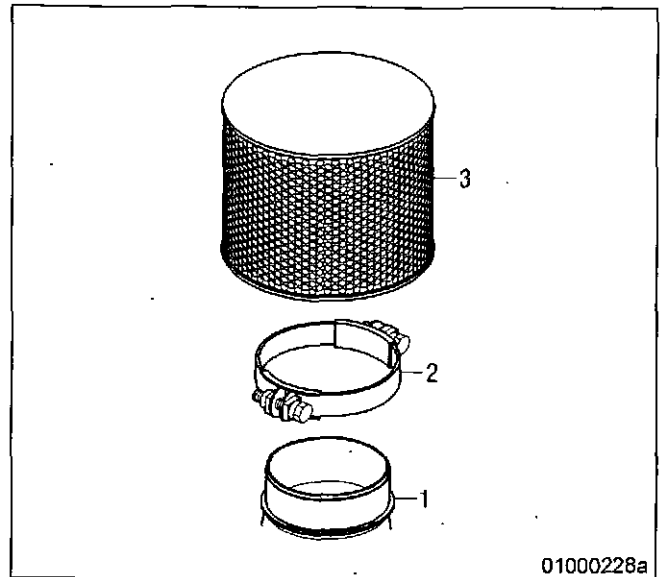

6.10 Air Intake

6.10.1 Service indicator – Signal ring position check

Preconditions

- Engine is stopped and starting disabled.

Signal ring position check

1. If the signal ring is completely visible in the control window (2), replace air filter (→ Page 163).
2. After installation of new filter, press reset button (1).
Result: Engaged piston with signal ring moves back to initial position.

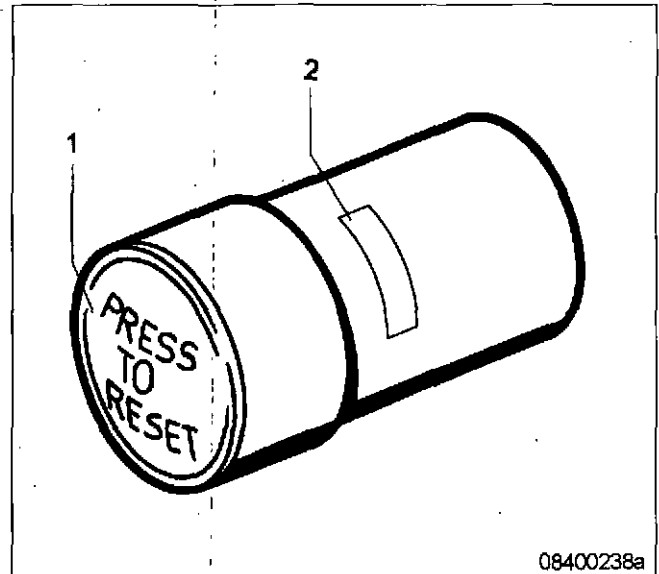

08400238a

6.11 Starting Equipment

6.11.1 Air starter – manual operation



DANGER

Unguarded rotating and moving engine components.

Risk of serious injury — danger to life!

- Before barring or starting the engine, ensure that nobody is in the danger zone.



WARNING

Engine noise above 85 dB (A).

Risk of damage to hearing!

- Wear ear protectors.

Air starter – manual operation

1. Press pushbutton for manual start and hold it.
2. Allow compressed air to enter the air starter until the engine fires evenly.
3. Release pushbutton.

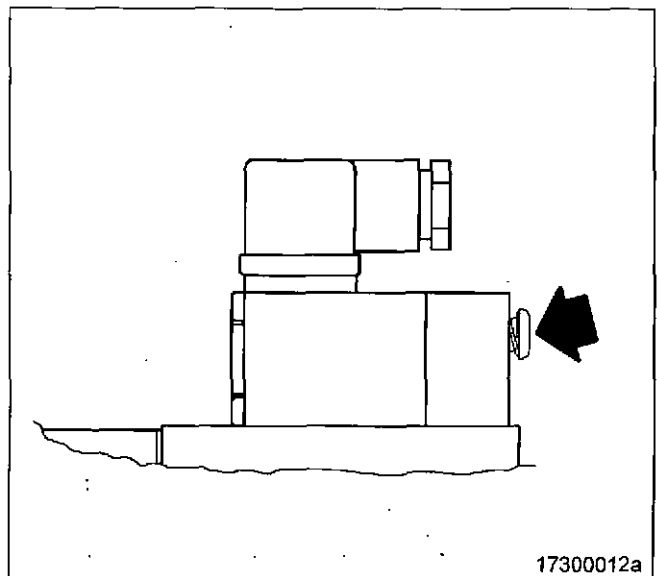

6.11.2 Starter – Condition check

Preconditions

- Engine is stopped and starting disabled.

Starter – Condition check

1. Check starter securing screws for secure seating.
2. Tighten loose screw connections.
3. Check wiring (→ Page 194).

6.12 Lube Oil System, Lube Oil Circuit

6.12.1 Engine oil – Level check

Preconditions

- Engine is stopped and starting disabled.

Checking oil level prior to engine start

1. Withdraw dipstick from guide tube and wipe it.
2. Insert dipstick into guide tube up to the stop, withdraw after approx. 10 seconds and check oil level.

Note: After extended standstill, the oil level may exceed the mark (1) by up to 2 cm. This can be caused by oil flowing from e.g. oil filter or heat exchanger back to the oil pan.

3. The oil level must reach the mark (1) or exceed the mark (1) by up to 2 cm.
4. If necessary, top up to the mark (1) (→ Page 170).
5. Insert dipstick into guide tube up to the stop.

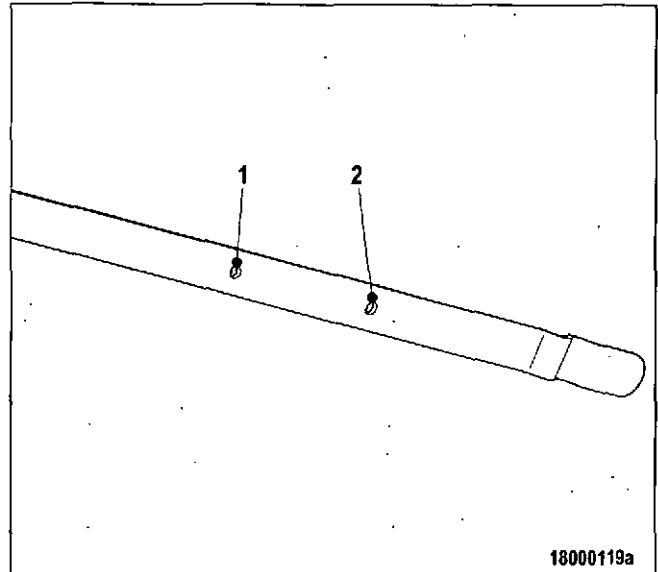

Checking oil level after the engine is stopped

1. 5 minutes after stopping the engine, remove oil dipstick from the guide tube and wipe it.
2. Insert dipstick into guide tube up to the stop, withdraw after approx. 10 seconds and check oil level.
3. Oil level must be between marks (1) and (2).
4. If necessary, top up to the mark (1) (→ Page 170).
5. Insert dipstick into guide tube up to the stop.

6.12.2 Engine oil – Change

Preconditions

- Engine is stopped and starting disabled.
- Engine is at operating temperature.
- MTU Fluids and Lubricants Specifications (A001061/..) are available.

Special tools

Designation / Use	Part No.	Qty.
Torque wrench, 40-200 Nm	F30027337	1
Ratchet adapter	F30027341	1

Material

Designation / Use	Part No.	Qty.
Engine oil		

Spare parts

Designation / Use	Part No.	Qty.
Sealing ring		



Hot oil.

Oil can contain combustion residues which are harmful to health.

Risk of injury and poisoning!

- Wear protective clothing, gloves, and goggles / safety mask.
- Avoid contact with skin.
- Do not inhale oil vapor.

Oil change without semirotary hand pump: Draining oil at drain plug(s) on oil pan

1. Provide a suitable container in which to collect the oil.
2. Remove drain plug(s) and drain oil.
3. Install drain plug(s) with new sealing ring.

Oil change using semirotary hand pump: Oil extraction

1. Provide a suitable container in which to collect the oil.
2. Extract all oil from oil pan using the hand pump.

Draining residual oil at equipment carrier

1. Provide a suitable container in which to collect the oil.
2. Remove drain plug (1) and drain oil (approx. 7 liters) from oil heat exchanger and oil filter.
3. Remove drain plugs (2) and (3) and drain oil:
 - at drain plug (2) approx. 12 liters
 - at drain plug (3) approx. 5 liters
4. Replace engine oil filter (→ Page 173).
5. Install drain plug(s) with new sealing ring.
6. Tighten drain plugs (2) and (3) with torque wrench to the specified torque 100 Nm +10 Nm.

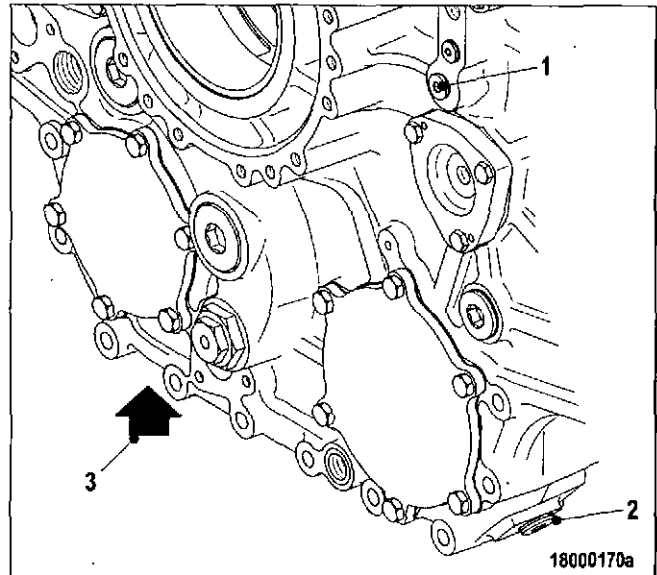
**Filling with new oil**

1. Open cover of filler neck.
2. Pour oil in at filler neck up to "max." mark at oil dipstick.
3. Close cover of filler neck.
4. Check engine oil level (→ Page 169).
5. After oil change and oil filter replacement, bar engine with starting system (→ Page 132).

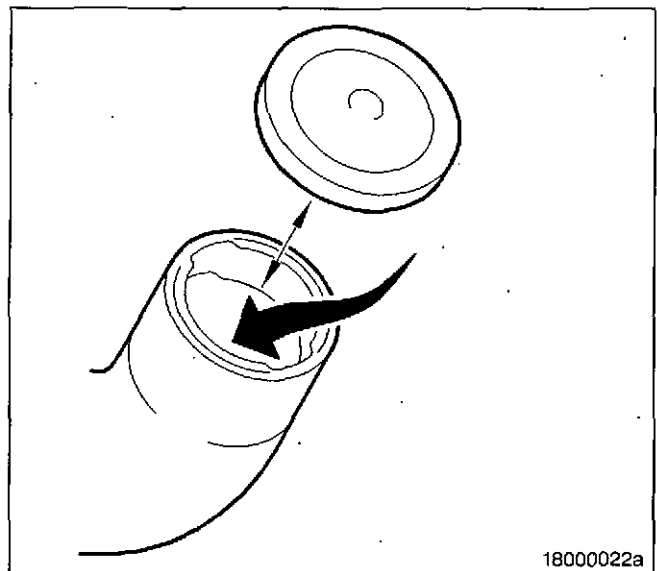

6.12.3 Engine oil – Sample extraction and analysis

Preconditions

- MTU Fluids and Lubricants Specifications (A001061/..) are available.

Special tools

Designation / Use	Part No.	Qty.
MTU test kit	5605892099/00	1



Unguarded rotating and moving engine components.
Risk of serious injury – danger to life!
 • Take special care when working on a running engine.



Hot oil.
 Oil can contain combustion residues which are harmful to health.
Risk of injury and poisoning!
 • Wear protective clothing, gloves, and goggles / safety mask.
 • Avoid contact with skin.
 • Do not inhale oil vapor.



Engine noise above 85 dB (A).
Risk of damage to hearing!
 • Wear ear protectors.

Engine oil – Sample extraction and analysis

1. With the engine running at operating temperature, open screw on centrifugal oil filter carrier by 1 to 2 rotations.
2. Drain approx. 2 liters engine oil to flush out the oil sludge.
3. Drain approx. 1 liter engine oil into a clean container.
4. Close screw.
5. Using the equipment and chemicals of the MTU test kit, examine engine oil for:
 - Dispersion capability (spot test);
 - Water content;
 - Dilution by fuel.

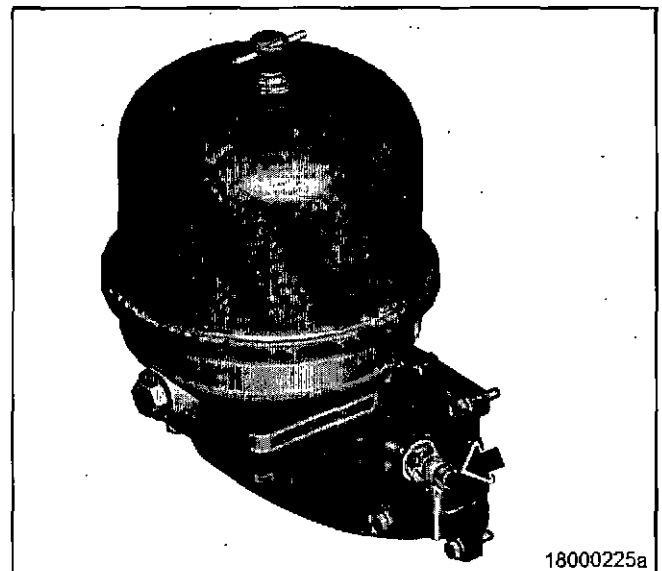

18000225a

6.13 Oil Filtration / Cooling

6.13.1 Engine oil filter – Replacement

Preconditions

- Engine is stopped and starting disabled.

Special tools

Designation / Use	Part No.	Qty.
Filter wrench	F30379104	

Material

Designation / Use	Part No.	Qty.
Engine oil		

Spare parts

Designation / Use	Part No.	Qty.
Oil filter		



WARNING

Hot oil.

Oil can contain combustion residues which are harmful to health.

Risk of injury and poisoning!

- Wear protective clothing, gloves, and goggles / safety mask.
- Avoid contact with skin.
- Do not inhale oil vapor.

Engine oil filter – Replacement

1. Remove oil filter using the filter wrench.
2. Clean the sealing surface of the filter head.
3. Check condition of the new sealing ring and coat it with oil.
4. Screw on and tighten new oil filter by hand.
5. Replace further oil filters in the same way.
6. After each oil change and filter replacement, bar engine with starting system (→ Page 132).
7. Check oil level (→ Page 169).

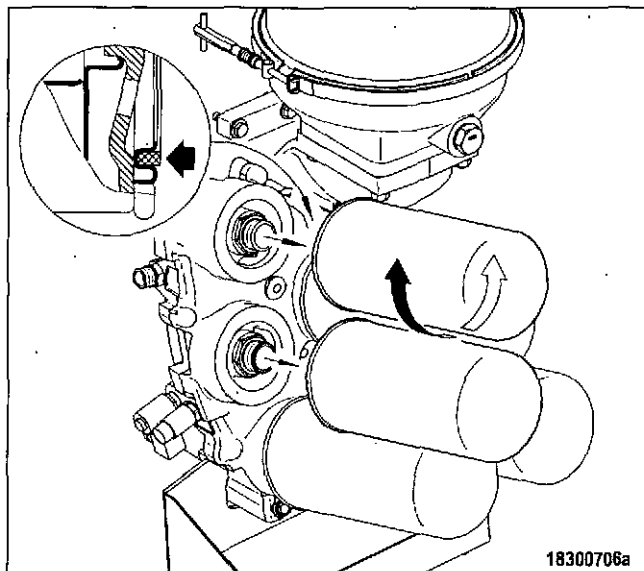

18300706a

6.13.2 Centrifugal oil filter – Cleaning and filter-sleeve replacement

Preconditions

- Engine is stopped and starting disabled.

Special tools

Designation / Use	Part No.	Qty.
Torque wrench, 6-50 Nm	F30027336	1

Material

Designation / Use	Part No.	Qty.
Cleaner Hakutex 60		

Spare parts

Designation / Use	Part No.	Qty.
Filter sleeve		
Sealing ring		
Sealing ring		



WARNING

Hot oil.
Oil can contain combustion residues which are harmful to health.
Risk of injury and poisoning!

- Wear protective clothing, gloves, and goggles / safety mask.
- Avoid contact with skin.
- Do not inhale oil vapor.



WARNING

Compressed air.
Risk of injury!

- Do not direct compressed-air jet at persons.
- Wear protective goggles / safety mask and ear protectors.

Centrifugal oil filter – Cleaning and filter-sleeve replacement

1. Remove clamp (3).
2. Release Tommy nut (1) and take off cover (2).
3. Carefully lift rotor (6), allow oil to drain and remove from housing.
4. Holding the rotor (6) firmly, release rotor cover nut (7).
5. Take off rotor cover (8).
6. Remove filter sleeve (10).
7. Measure thickness of oil residues on filter sleeve (10).
8. If maximum layer thickness of oil residues exceeds 45 mm, shorten maintenance interval.
9. Disassemble rotor tube (11), conical disk (12) and rotor base (14).
10. Wash rotor cover (8), rotor tube (11), conical disk (12) and rotor base (14) with cleaner.
11. Blow out with compressed air.
12. Check sealing ring (13), fit new one if necessary.
13. Assemble rotor tube (11), conical disk (12) and rotor base (14) with sealing ring (13).
14. Insert new filter sleeve (10) in rotor tube (11) with the smooth paper surface facing the wall.
15. Check sealing ring (9), fit new one if necessary.
16. Mount rotor cover (8) with sealing ring (9).
17. Tighten rotor cover nut (7) with 35 Nm to 45 Nm.
18. Place rotor (6) in housing (5) and check for ease of movement.
19. Check sealing ring (4), fit new one if necessary.
20. Fit sealing ring (4) on housing (5).
21. Fit cover (2).
22. Tighten Tommy nut (1) by hand.
23. Fit clamp (3) and tighten with 8 Nm to 10 Nm.
24. Tighten cover nut (1) with 5 Nm to 7 Nm.

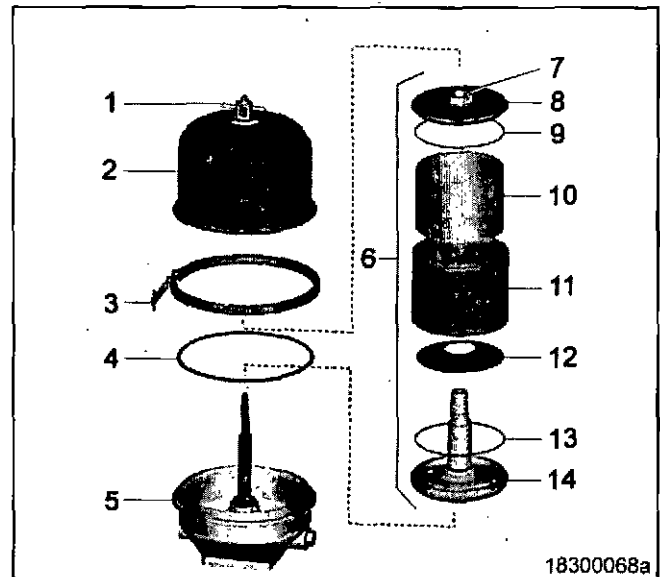

6.14 Coolant Circuit, General, HT Circuit

6.14.1 Engine coolant level – Check

Preconditions

- Engine is stopped and starting disabled.
- MTU Fluids and Lubricants Specification (A001061/..) is available.



Coolant is hot and under pressure.

Risk of injury and scalding!

- Let the engine cool down.
- Wear protective clothing, gloves, and goggles / safety mask.

Coolant-level check at filler neck:

1. Turn breather valve of filler neck on coolant expansion tank counterclockwise to first stop and allow pressure to escape.
2. Continue to turn breather valve counterclockwise and remove.
3. Check coolant level (coolant must be visible at the lower edge of the cast-in eye).

Coolant-level check at external cooler:

1. Check coolant level (coolant must be visible at marking plate).
2. If required, top up with treated coolant (→ Page 179).
3. Check and clean breather valve.
4. Set breather valve onto filler neck and close it.

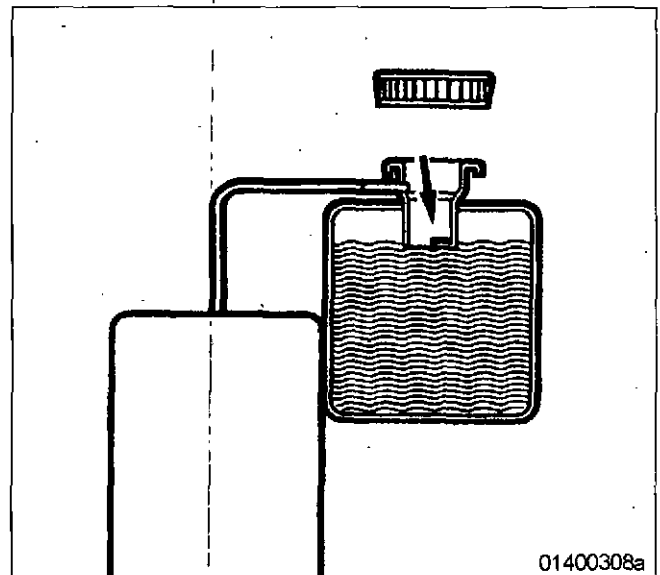

Coolant-level check by means of level sensor:

1. Switch on engine control system and check readings on the display.
2. If required, top up with treated coolant (→ Page 179).

6.14.2 Engine coolant – Change

Material

Designation / Use	Part No.	Qty.
Engine coolant		

Drain engine coolant (→ Page 178).

Fill with engine coolant (→ Page 179).

6.14.3 Engine coolant – Draining

Preconditions

- Engine is stopped and starting disabled.



WARNING

Coolant is hot and under pressure.

Risk of injury and scalding!

- Let the engine cool down.
- Wear protective clothing, gloves, and goggles / safety mask.

Preparatory steps

1. Provide an appropriate container to drain the coolant into.
2. Switch off preheating unit.

Engine coolant – Draining

1. Turn breather valve of coolant expansion tank counterclockwise until the first stop and allow pressure to escape.
2. Continue to turn breather valve counterclockwise and remove.
3. Draw off segregated corrosion inhibitor oil in expansion tank through the filler neck.
4. Open drain cocks or drain plugs and drain coolant at the following points:
 - Preheating unit;
 - Thermostat housing (arrow)
 - U-bend (arrow)
 - HT coolant pump elbow;
 - Crankcase, left and right side.
5. Close all open drain points.
6. Place breather valve on filler neck and close.

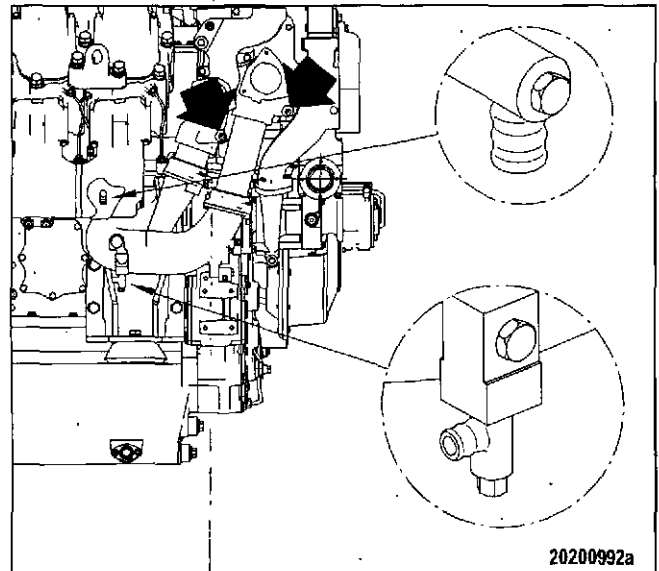

20200992a

Filling coolant with pump

1. Connect appropriate pump with hose to the drain valve of the engine coolant pump (arrow).

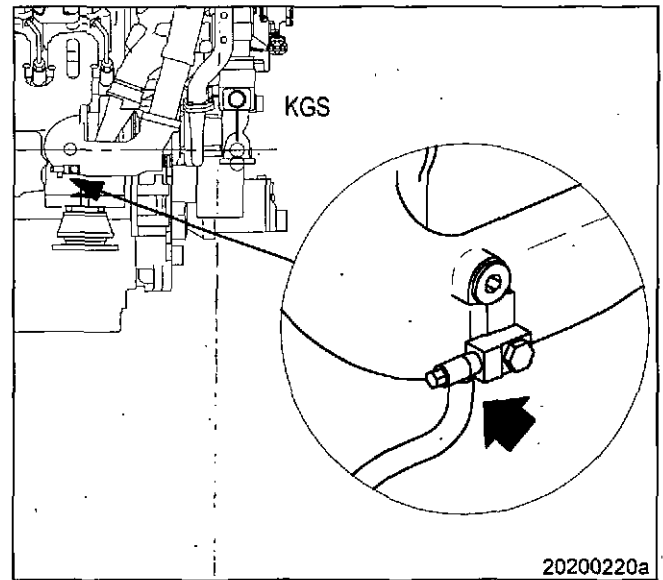

2. Open vents at distributor and exhaust turbochargers (arrowed).
3. Open drain valve and pump coolant into engine at 0.5 bar minimum.
4. When coolant emerges from the vent points, close vent points successively from the lowest point up to the highest one.
5. Fill expansion tank until overflow edge is reached.
6. Close drain valve.
7. Check proper condition of breather valve on coolant expansion tank, clean sealing faces if required.
8. Fit breather valve and close it.
9. Start engine (→ Page 55).
10. After the engine has run at unloaded condition for 10 seconds, stop engine (→ Page 59).
11. Turn breather valve of filler neck on coolant expansion tank counterclockwise to first stop and allow pressure to escape.
12. Continue to turn breather valve counterclockwise and remove.
13. Check coolant level (→ Page 176) and top up with coolant if required:
 - 13.1. Fill in coolant in expansion tank until the coolant level at top edge of filler neck remains constant.
 - 13.2. Fit breather valve and close it.
14. Repeat the steps from "Start engine" → 9. until coolant is no longer needed to be topped up.
15. Disconnect pump and hose.

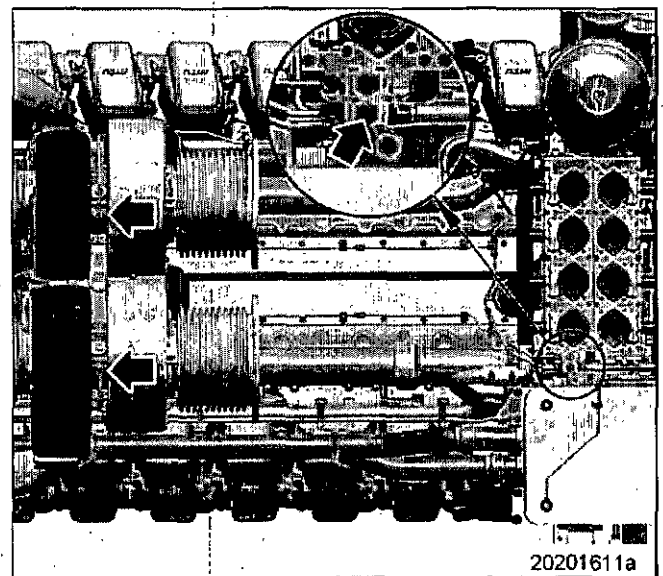

Alternatively: Filling coolant through filler neck

1. Open vents at distributor and exhaust turbochargers (arrowed).
2. Fill in coolant in expansion tank until the coolant level at top edge of filler neck remains constant.
3. When coolant emerges from the vent points, close vent points successively from the lowest point up to the highest one.
4. Check proper condition of breather valve on coolant expansion tank, clean sealing faces if required.
5. Fit breather valve and close it.
6. Start engine (→ Page 55).
7. After the engine has run at unloaded condition for 10 seconds, stop engine (→ Page 59).
8. Turn breather valve of filler neck on coolant expansion tank counterclockwise to first stop and allow pressure to escape.
9. Turn breather valve counterclockwise and remove.
10. Check coolant level (→ Page 176) and top up with coolant through the filler neck if required:
 - 10.1. Fill in coolant in expansion tank until the coolant level at top edge of filler neck remains constant.
 - 10.2. Fit breather valve and close it.
11. Repeat the steps from "Start engine" → 6. until coolant is no longer needed to be topped up.

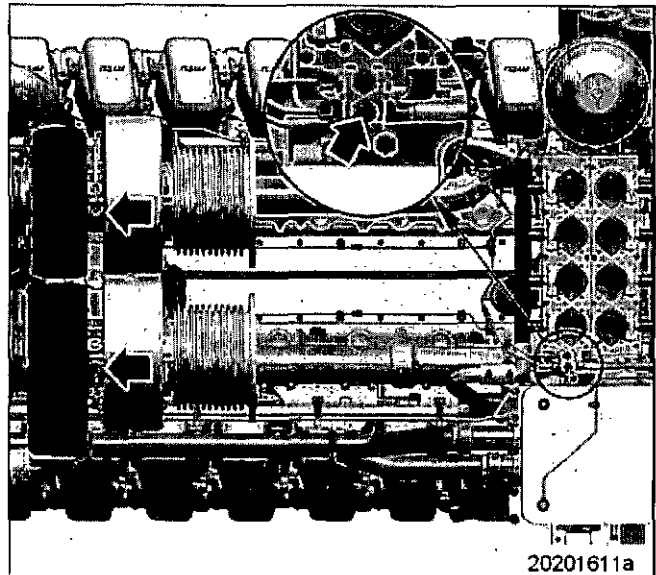
**Final steps**

1. Start the engine and operate it at unloaded condition for some minutes.
2. Check coolant level (→ Page 176) and top up with coolant if required.

6.14.5 Engine coolant pump – Relief bore check



Unguarded rotating and moving engine components.
Risk of serious injury – danger to life!
• Take special care when working on a running engine.



Engine noise above 85 dB (A).
Risk of damage to hearing!
• Wear ear protectors.

Engine coolant pump – Relief bore check

1. Check relief bore for oil and water discharge.
2. Stop the engine (→ Page 59) and disable engine start, observe general safety instructions.
3. Clean the relief bore with a wire if it is dirty.
 - Permissible coolant discharge: up to 10 drops per hour;
 - Permissible oil discharge: up to 5 drops/hour;
4. If discharge exceeds the specified limits: Contact Service.

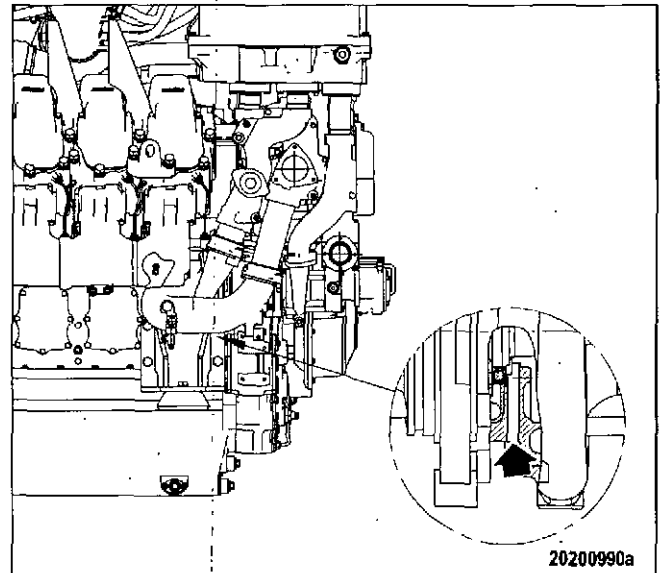

6.14.6 Engine coolant – Sample extraction and analysis

Preconditions

- MTU Fluids and Lubricants Specifications (A001061/..) are available.

Special tools

Designation / Use	Part No.	Qty.
MTU test kit	5605892099/00	1



Unguarded rotating and moving engine components.

Risk of serious injury – danger to life!

- Take special care when working on a running engine.



Coolant is hot and under pressure.

Risk of injury and scalding!

- Let the engine cool down.
- Wear protective clothing, gloves, and goggles / safety mask.



Engine noise above 85 dB (A).

Risk of damage to hearing!

- Wear ear protectors.

Engine coolant – Sample extraction and analysis

1. With the engine running, open drain valve (1).
2. Flush sample-extraction point by draining approx. 1 liter coolant.
3. Drain approx. 1 liter coolant into a clean container.
4. Close drain valve (1).
5. Using the equipment and chemicals of the MTU test kit, examine coolant for:
 - antifreeze concentration;
 - corrosion inhibitor concentration;
 - pH value.
6. For engine coolant change intervals (→MTU Fluids and Lubricants Specifications).

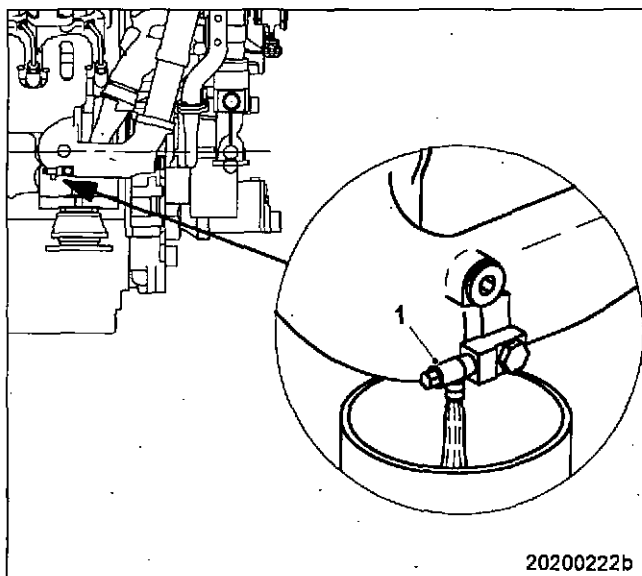

20200222b

6.15 LT Circuit

6.15.1 Charge-air coolant – Level check

Preconditions

- Engine is stopped and starting disabled.
- MTU Fluids and Lubricants Specifications (A001061/..) are available.



WARNING

Coolant is hot and under pressure.

Risk of injury and scalding!

- Let the engine cool down.
- Wear protective clothing, gloves, and goggles / safety mask.

Charge-air coolant level check at filler neck:

1. Turn breather valve of filler neck on coolant expansion tank counterclockwise to first stop and allow pressure to escape.
2. Continue to turn breather valve counterclockwise and remove.
3. Check coolant level (coolant must be visible at marking plate).
4. If required, top up with treated coolant (→ Page 187).
5. Check proper condition of breather valve, clean sealing faces if required.
6. Place breather valve onto filler neck and close.

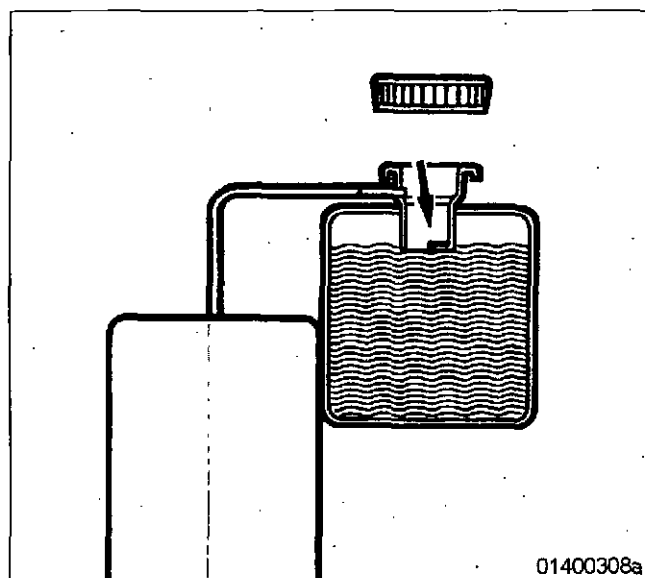

Charge-air coolant level check by means of level sensor:

1. Switch engine control system ON and check display (coolant level is automatically monitored by the engine control system).
2. If required, top up with treated coolant (→ Page 187).

6.15.2 Charge-air coolant – Change

Material

Designation / Use	Part No.	Qty.
Coolant		

Drain charge-air coolant (→ Page 186).

Fill charge-air coolant circuit (→ Page 187).

6.15.3 Charge-air coolant – Draining

Preconditions

- Engine is stopped and starting disabled.

Spare parts

Designation / Use	Part No.	Qty.
Sealing ring		



WARNING

Coolant is hot and under pressure.

Risk of injury and scalding!

- Let the engine cool down.
- Wear protective clothing, gloves, and goggles / safety mask.

Charge-air coolant – Draining

1. Provide an appropriate container to drain the coolant into.
2. Turn breather valve of coolant expansion tank counterclockwise until the first stop and allow pressure to escape.
3. Continue to turn breather valve counterclockwise and remove.
4. Draw off segregated corrosion inhibitor oil in expansion tank through the filler neck.
5. Open drain valves and drain plugs and drain coolant at the following points:
 - at the LT coolant pump
 - at the LT thermostat housing.
6. Draining of residual coolant:
 - at the intercooler
7. Close all drain valves and install drain plugs with new sealing rings.
8. Place breather valve on filler neck and close.

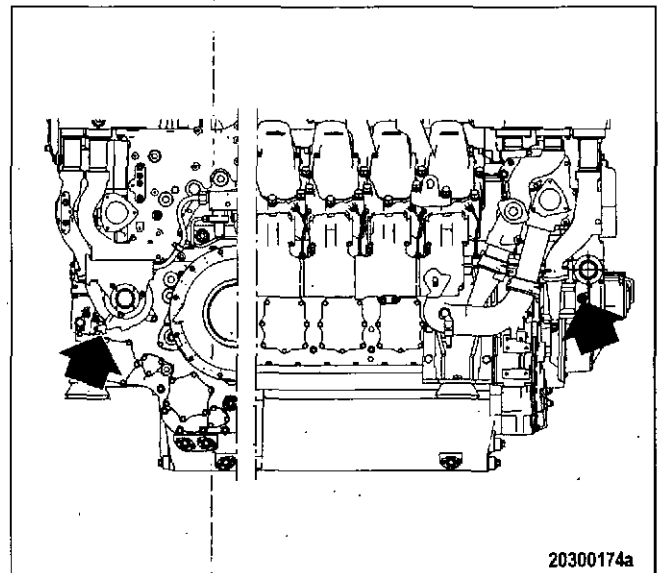

20300174a

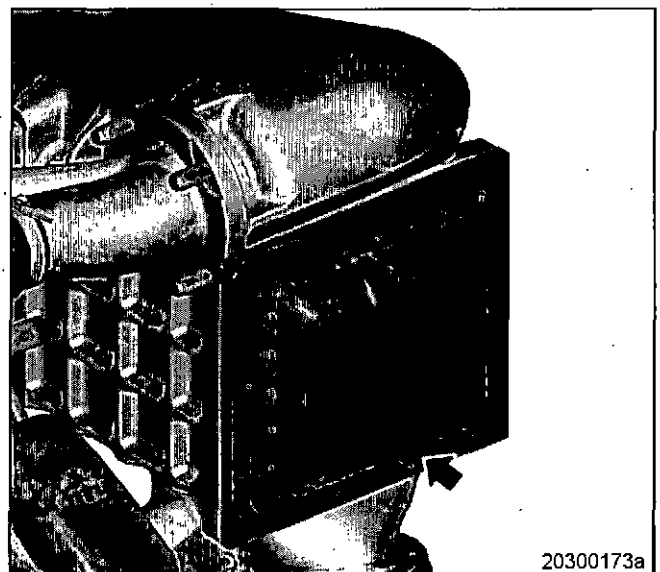

20300173a

6.15.4 Charge-air coolant – Filling

Preconditions

- Engine is stopped and starting disabled.
- MTU Fluids and Lubricants Specifications (A001061/..) are available.

Material

Designation / Use	Part No.	Qty.
Charge-air coolant		



WARNING

Coolant is hot and under pressure.

Risk of injury and scalding!

- Let the engine cool down.
- Wear protective clothing, gloves, and goggles / safety mask.



CAUTION

Cold coolant in hot engine can cause thermal stress.

Formation of cracks in components!

- Fill / top up coolant only into cold engine.

Preparatory steps

1. Turn breather valve of coolant expansion tank counterclockwise to the first stop and allow pressure to escape.
2. Continue to turn breather valve counterclockwise and remove.

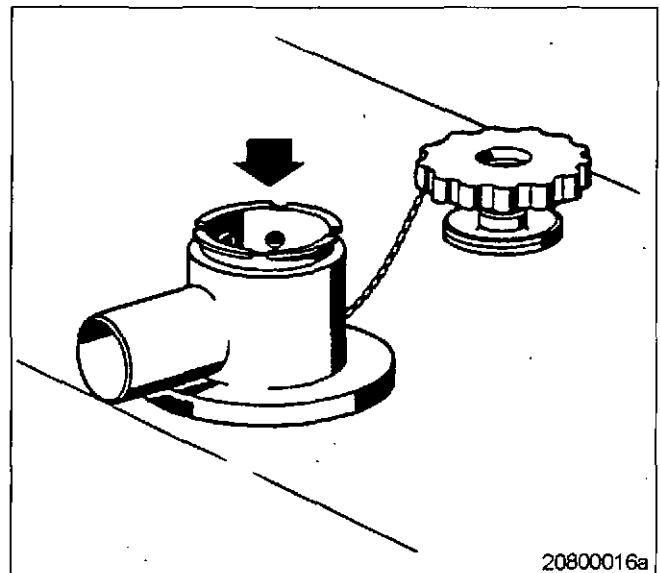

20800016a

Filling coolant with pump

1. Connect a suitable pump with a hose to the drain valve (arrowed).
2. Undo the vent line union at the distributor piece (arrowed).
3. Open drain valve and pump coolant into engine at 0.5 bar minimum.
4. Tighten the union (arrowed) if coolant leaks out at the loose union.
5. Fill expansion tank until overflow edge is reached.
6. Close drain valve.
7. Check proper condition of breather valve and clean sealing faces if required.
8. Place breather valve on filler neck and close.
9. Start engine (→ Page 55).
10. After the engine has run without load for 10 seconds, stop the engine (→ Page 59).
11. Turn breather valve of coolant expansion tank counterclockwise to the first stop and allow pressure to escape.
12. Continue to turn breather valve counterclockwise and remove.
13. Check coolant level (→ Page 184) and top up coolant as necessary:
 - 13.1. Fill in coolant in expansion tank until coolant level at top edge of filler neck remains constant.
 - 13.2. Place breather valve on filler neck and close.
14. Repeat the steps from "Start engine" → 9. until coolant is no longer needed to be topped up.
15. Disconnect pump and hose.

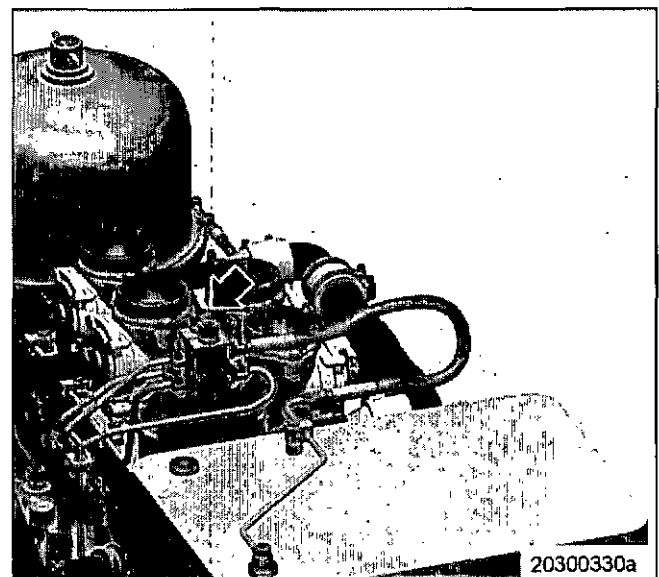
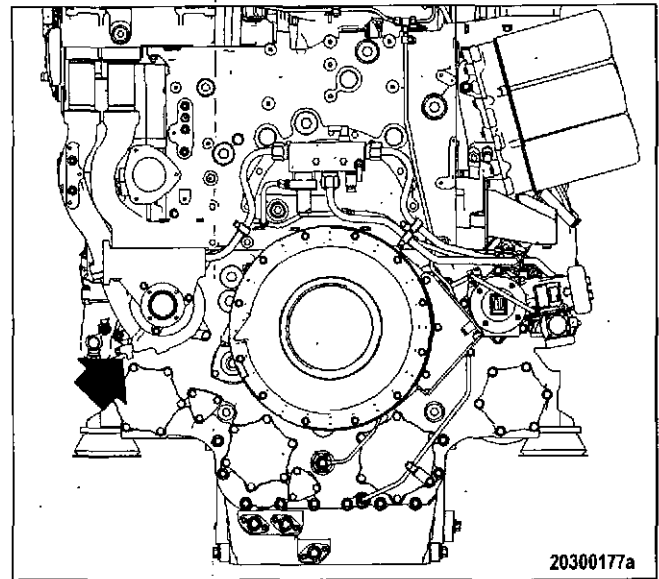

Alternatively: filling coolant through filler neck.

1. Undo the vent line union at the distributor piece (arrowed).
2. Fill in coolant in expansion tank via filler neck until coolant level at top edge of filler neck remains constant.
3. Tighten the union (arrowed) if coolant leaks out at the loose union.
4. Check proper condition of breather valve on coolant expansion tank and clean sealing faces if required.
5. Fit breather valve and close.
6. Start engine (→ Page 55).
7. After the engine has run without load for 10 seconds, stop the engine (→ Page 59).
8. Turn breather valve of coolant expansion tank counterclockwise to the first stop and allow pressure to escape.
9. Turn breather valve counterclockwise and remove.
10. Check coolant level (→ Page 184) and top up coolant via filler neck as necessary:
 - 10.1. Top up coolant in expansion tank via filler neck until coolant level at top edge of filler neck remains constant.
 - 10.2. Fit breather valve and close.
11. Repeat the steps from "Start engine" → 6. until coolant is no longer needed to be topped up.

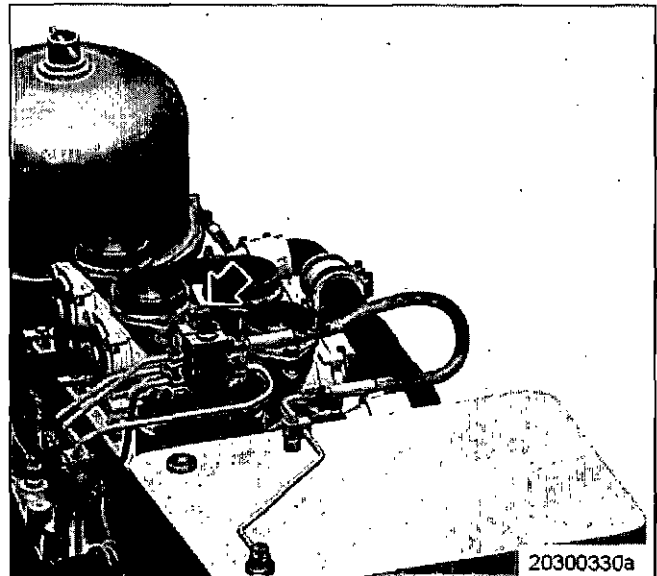
**Final steps**

1. Start the engine and operate it at unloaded condition for some minutes.
2. Check coolant level (→ Page 184) and top up coolant as necessary.

6.15.5 Charge-air coolant pump – Relief bore check



DANGER

Unguarded rotating and moving engine components.

Risk of serious injury – danger to life!

- Take special care when working on a running engine.



WARNING

Engine noise above 85 dB (A).

Risk of damage to hearing!

- Wear ear protectors.

Charge-air coolant pump – Relief bore check

1. Check relief bore for oil and water discharge.
2. Stop the engine (→ Page 59) and disable engine start, observe general safety instructions.
3. Clean the relief bore with a wire if it is dirty.
 - Permissible coolant discharge: up to 10 drops per hour;
 - Permissible oil discharge: up to 5 drops per hour;
4. If discharge exceeds the specified limits: Contact Service.

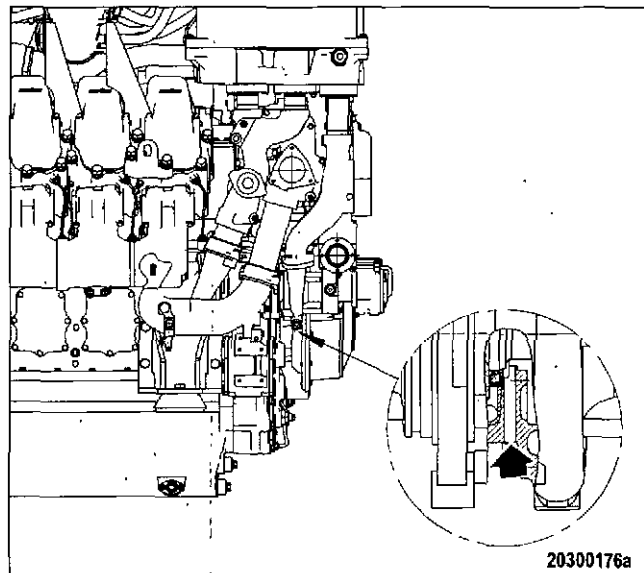

20300176a

6.16 Belt Drive

6.16.1 Drive belt – Condition check

Preconditions

- Engine is stopped and starting disabled.
- Guard is removed.

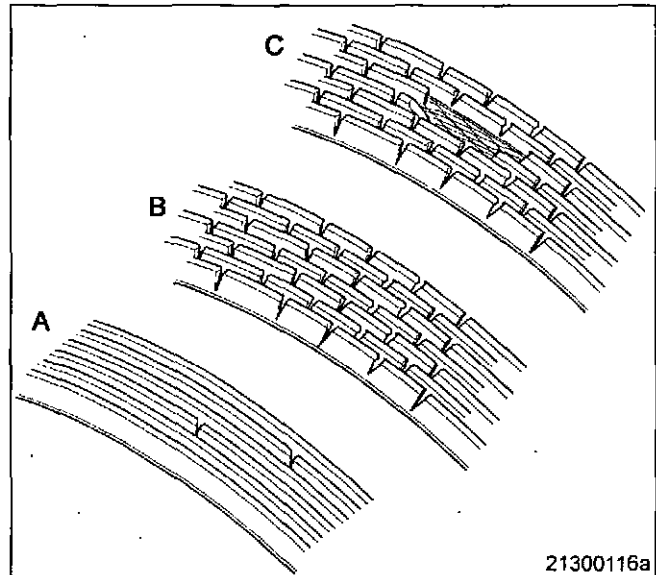

Item	Findings	Task
Drive belt A	Breaks in a few individual places	None
Drive belt	Belt is oily, shows signs of overheating	Replace (→ Page 193)
Drive belt B	Breaks around the entire circumference	
Drive belt C	Areas of belt material missing	

6.17 Battery-Charging Generator

6.17.1 Battery-charging generator drive – Drive belt tension adjustment

Preconditions

- Engine is stopped and starting disabled.



WARNING

Spring/circlip/tensioning roller preload.

Risk of injury!

- Only use specified tool and equipment.

Adjusting belt tension

1. Remove guard cover.
2. Slacken screws (1) and (2) by half a turn.
Result: Belt tensioner moves against the drive belt and tensions it.
3. Use torque wrench to tighten screw (1) to the specified torque 42 Nm and screw (2) to 60 Nm up to 65 Nm.
4. Install guard cover.

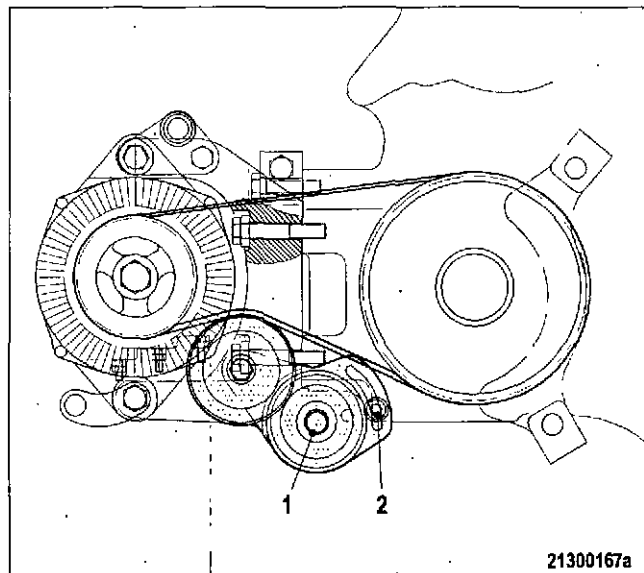

21300167a

6.17.2 Battery-charging generator drive – Drive belt replacement

Preconditions

- Engine is stopped and starting disabled.

Spare parts

Designation / Use	Part No.	Qty.
Drive belt		



WARNING

Spring/circlip/tensioning roller preload.

Risk of injury!

- Only use specified tool and equipment.

Battery-charging generator drive – Drive belt replacement

1. Remove guard cover.
2. Slacken screws (1) and (2) by half a turn.
3. Place socket adapter or box wrench on screw (3) and press belt tensioner in the direction indicated by the arrow as far as it will go.
4. Tighten screw (2).
5. Remove the used drive belt.
6. Fit new drive belt.
7. Slacken screw (2) by half a turn.
Result: Belt tensioner moves against the drive belt and tensions it.
8. Use torque wrench to tighten screw (1) to the specified torque 42 Nm and screw (2) to 60 Nm up to 65 Nm.
9. Install guard cover.
10. Readjust belt tension after 30 minutes and again after 8 hours engine runtime. (→ Page 192)

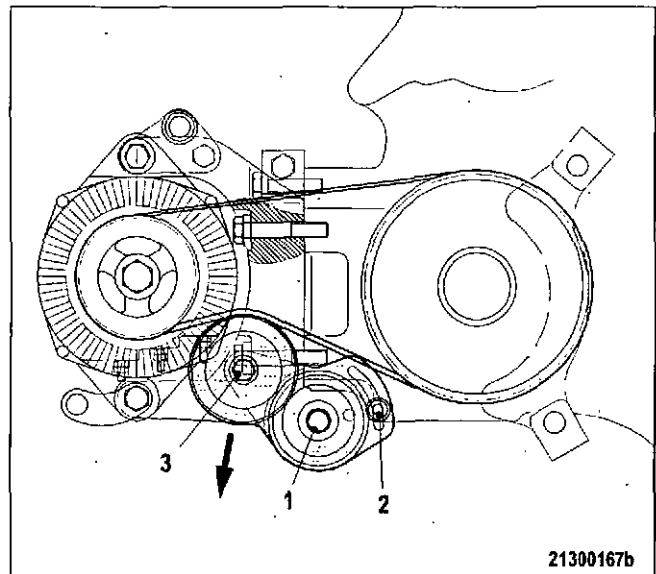

21300167b

6.18 Cabling, General for Engine / Gearbox / Unit

6.18.1 Engine wiring – Check

Preconditions

- Engine is stopped and starting disabled.

Material

Designation / Use	Part No.	Qty.
Isopropyl alcohol	46181	1

Engine wiring – Check

1. Check securing screws of cable clamps on the engine and tighten loose screw connections.
2. Make certain that cables are securely seated in clamps and cannot move freely.
3. Check cable binders for secure seating, tighten loose cable binders.
4. Replace defective cable binders.
5. Inspect electrical components visually for damage:
 - connector housings;
 - contacts;
 - connector sockets;
 - cables and terminals;
 - plug-in contacts.
6. If conductors are damaged (→Contact Service)
7. Clean dirty connector housings, sockets and contacts with isopropyl alcohol.
8. Make certain that all sensor connectors are securely latched.

6.19 Accessories for Engine Governor (Electronic) / Control System

6.19.1 Engine governor and connectors – Cleaning

Preconditions

- Engine is stopped and starting disabled.

Material

Designation / Use	Part No.	Qty.
Isopropyl alcohol		

Engine governor and connectors – Cleaning

1. Remove coarse dirt from housing surface using a cloth moistened with isopropyl alcohol.
2. Remove dirt from connector and cable surfaces with isopropyl alcohol.
3. Check legibility of cable labels. Clean or replace illegible labels.

Cleaning heavily contaminated connectors on engine governor

1. Release latches of connectors and withdraw connectors.
2. Clean connector housings, connector socket housings and all contacts with isopropyl alcohol.
3. When connectors, sockets and all contacts are dry: Fit connectors and secure latches.

6.19.2 Engine governor plug-in connections – Check

Preconditions

- Engine is stopped and starting disabled.

Checking plug-in connections on engine governor

1. Verify that all plug-in connections are securely seated.
2. Secure loose connectors and latch.

6.19.3 Engine governor – Removal and installation

Preconditions

- Engine is stopped and starting disabled.



Wrong engine governor installed.

Engine damage!

- When reassembling an engine, make sure that the governor with the data record for the given engine is installed.

Removing engine governor from engine

1. Note or mark assignment of cables and connectors.
2. Remove all screws (2).
3. Release lock (3) of connectors.
4. Withdraw all connectors.
5. Remove screws (1).
6. Take off engine governor.

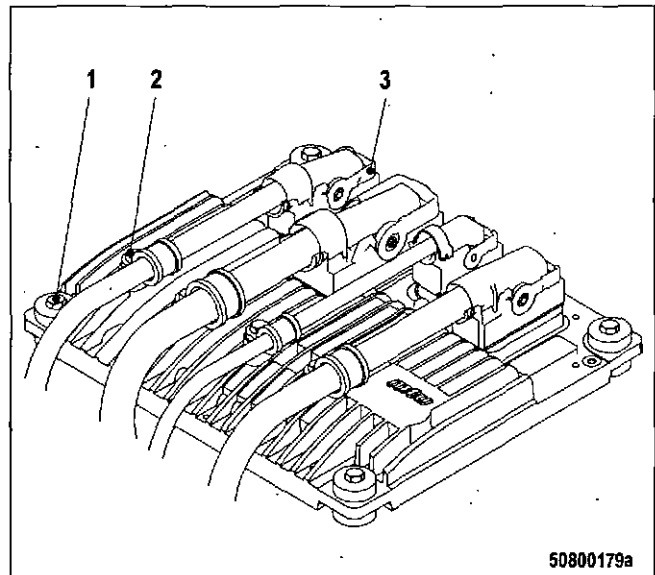

Installing engine governor on engine

1. For installation follow reverse sequence of working steps. Ensure that connectors are plugged in the correct socket.
2. Check rubber bearing before installation.
Result: If the rubber bearing is porous or defective, fit a new one.

7 Special Tools

7.1 Special tools

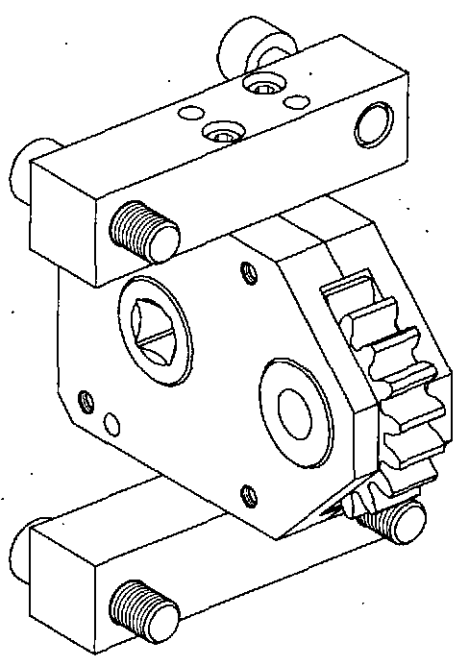
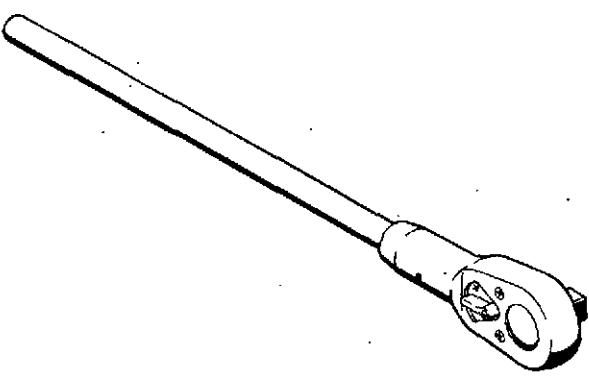

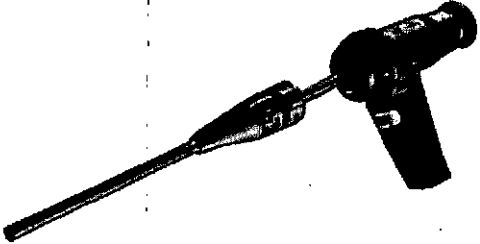
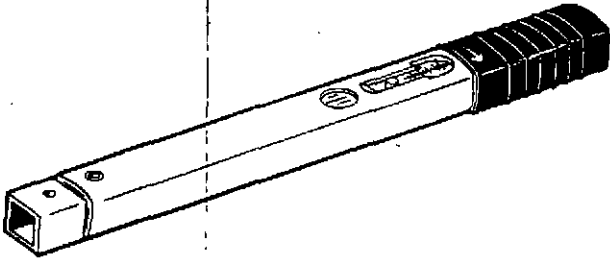
Part No.	Designation / Use	Qty.	
	Steam jet cleaner		
F6555766	Barring gear	1	
F30006212	Ratchet head with extension	1	

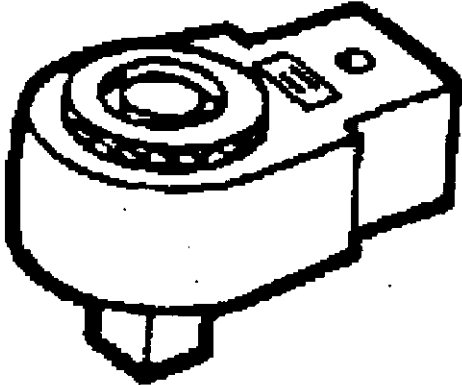
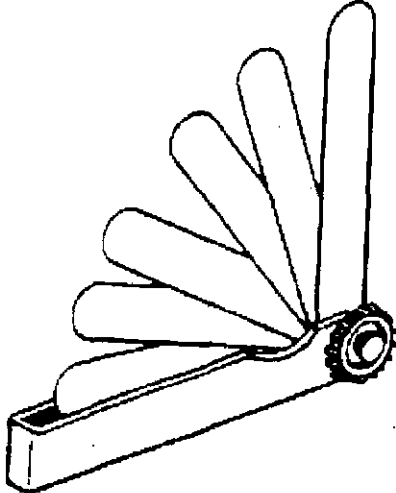

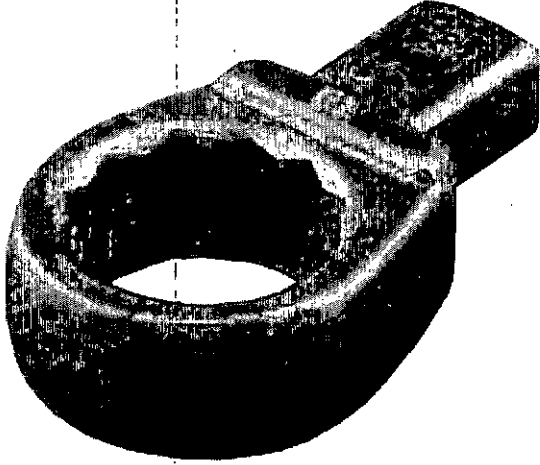
Part No.	Designation / Use	Qty.	
Y20097353	Rigid endoscope	1	 A rigid endoscope tool with a long, thin shaft and a T-shaped handle.
F30027336	Torque wrench 6-50 Nm	1	 A torque wrench with a long handle and a square drive end.

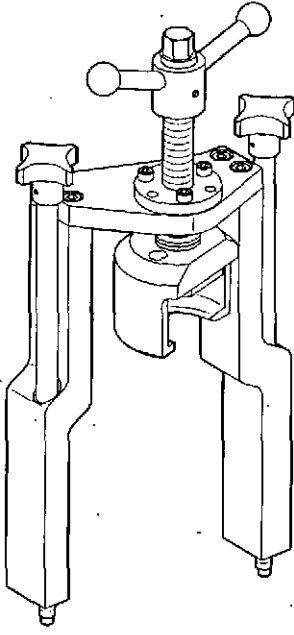
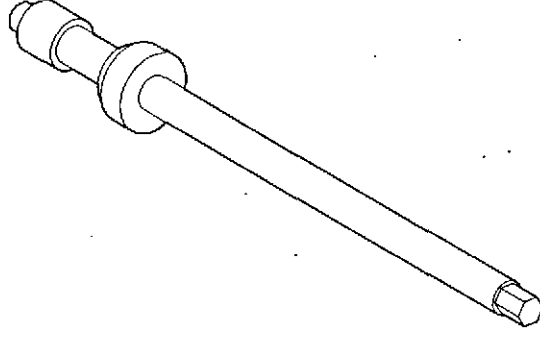
Part No.	Designation / Use	Qty.	
F30027340	Ratchet adapter	1	
Y20010128	Feeler gauge	1	

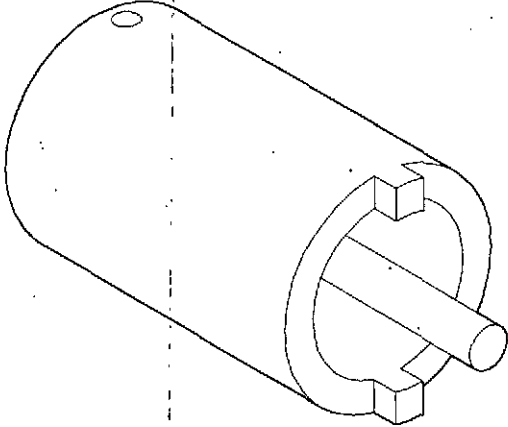
Part No.	Designation / Use	Qty.	
F30047446	Torque wrench, 60-320 Nm	1	
F30039526	Ring socket, 24 mm	1	

Part No.	Designation / Use	Qty.	
F6789889	Installation/removal tool for injector	1	
F30452739	Milling cutter	1	

Part No.	Designation / Use	Qty.	
F30452578	Slotted nut driver	1	
0015384230	Torque wrench 0.5-5 Nm	1	

Part No.	Designation / Use	Qty.	
F30510423	Torque wrench 10-60 Nm	1	
F30047446	Torque wrench 60-320 Nm	1	

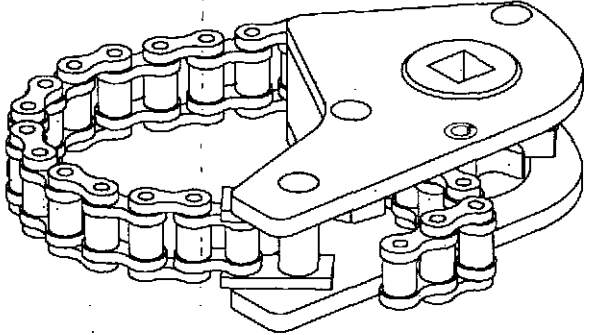
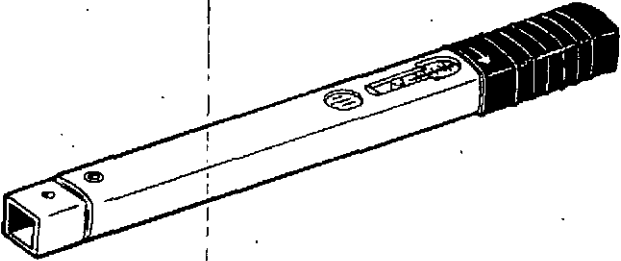
Part No.	Designation / Use	Qty.	
F30379104	Filter wrench	1	
F30027337	Torque wrench, 40-200 Nm	1	

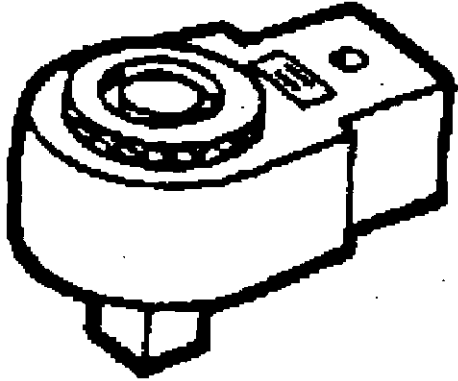
Part No.	Designation / Use	Qty.	
F30027341	Ratchet adapter	1	

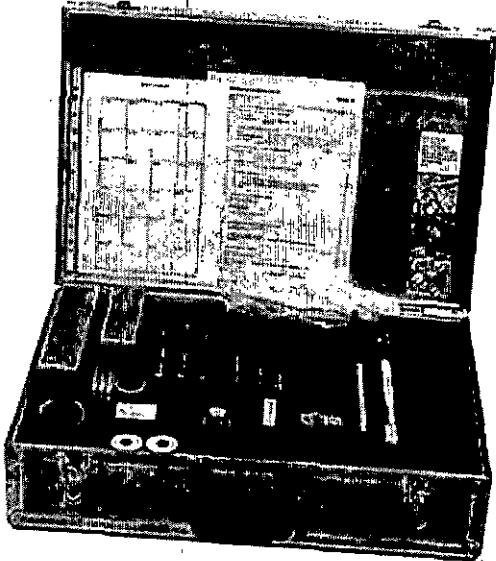
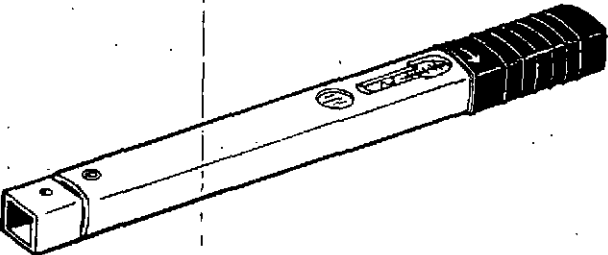
Part No.	Designation / Use	Qty.	
5605892099/00	MTU test kit	1	 <p data-bbox="1317 921 1474 947">5605892099/00</p>
F30027336	Torque wrench, 6-50 Nm	1	

8 Appendix

8.1 Manufacturer's documentation

See Manufacturer's documentation.

8.2 MTU-contact person/service partner

Service

We provide immediate attention through fast and direct access to our worldwide sales and service network.

On-site service

Skilled product experts will assist you with knowledge and experience and thus contribute to your business success.

For further information on our on-site service, visit: <http://www.mtu-online.com/mtu/wor/>

24h hotline

With our 24h hotline and the flexibility of our service staff, we are always ready to assist you - either during operation, for preventive maintenance, corrective work in case of malfunction or changed operating conditions, or for spare parts supply.

Your contact in our headquarters: Service-support@mtu-online.com

Spare parts service

Fast, straightforward and accurate identification of spare parts for your drive plant or vehicle fleet.

The right spare part at the right time, at the right place.

With this aim in mind, we can call on a globally networked spares logistics system,

- a central warehouse at headquarters and on-site stores at our subsidiary companies, agencies and service workshops.

Your contact in our headquarters:

E-Mail: spare.parts@mtu.online.com

Phone: +49 7541 908779

Fax: +49 7541 908102

8.3 Abbreviations

Abbreviation	Meaning	Explanation
A/D	Analog/Digital	Transformer: transforms sensor voltages into numeric values
AFRS	Air Filter Restriction Sensor	
ANSI	American National Standards Institute	
ATL	Abgasturbolader	Exhaust turbocharger
ATS	Air Temperature Sensor	
BR	Baureihe	Series
CAN	Controller Area Network	Data bus system, bus standard
CEL	Check Engine Light	1st function: Warning lamp (rectify fault as soon as possible) 2nd function: Read out fault codes
CKT	Circuit	
CLS	Coolant Level Sensor	Monitors coolant level
CPS	Coolant Pressure Sensor	Monitors coolant pressure
CTS	Coolant Temperature Sensor	Monitors coolant temperature
DDEC	Detroit Diesel Electronic Controls	Engine control system made by Detroit Diesel
DDL	Diagnostic Data Link	
DDR	Diagnostic Data Reader	
DIN	Deutsches Institut für Normung e. V.	German Standardization Organization, at the same time identifier of German standards ("Deutsche Industrie-Norm")
DL	Default Lost	Alarm: Default CAN bus failure
DT	Diagnostic Tool	
ECM	Electronic Control Module	Electronic control unit of the DDEC system
ECU	Engine Control Unit	Engine Governor
EDM	Engine Data Module	Storage module engine data
EEPROM	Electrically Erasable Programmable Read Only Memory	
EFPA	Electronic Foot Pedal Assembly	
EGR	Exhaust Gas Recirculation	
EMU	Engine Monitoring Unit	
EUI	Electronic Unit Injector	
FLS	Fluids and Lubricants Specifications	MTU Publication No. A01061/..
FPS	Fuel Pressure Sensor	Monitors fuel pressure

Abbreviation	Meaning	Explanation
FRS	Fuel - Differential Pressure Sensor	
FTS	Fuel Temperature Sensor	Monitors fuel temperature
FWCP	Fire Water Control Panel	
GND	Ground	
HI	High	Alarm: Measured value exceeds 1st maximum limit
HIHI	High High	Alarm: Measured value exceeds 2nd maximum limit
HT	High Temperature	
IDM	Interface Data Module	
INJ	Injector	
ISO	International Organization for Standardization	
KGS	Kraftgegenseite	Engine free end in accordance with DIN ISO 1204
KS	Kraftseite	Engine driving end in accordance with DIN ISO 1204
LED	Light Emitting Diode	
LO	LOW	Alarm: Measured value lower than 1st minimum limit
LOLO	Low Low	Alarm: Measured value lower than 2nd minimum limit
LSG	Limiting Speed Governor	
N/A	Not Applicable	
OEM	Original Equipment Manufacturer	
OI	Optimized Idle	
OLS	Oil Level Sensor	Monitors oil level
OPS	Oil Pressure Sensor	Monitors oil pressure
OTS	Oil Temperature Sensor	Monitors oil temperature
OT	Oberer Totpunkt	Top dead center
PAN	Panel	
PIM	Peripheral Interface Module	
PWM	Pulsewidth modulated	
P-xyz	Pressure-xyz	Pressure measuring point xyz
RL	Redundancy Lost	Alarm: Redundant CAN bus failure
SAE	Society of Automotive Engineers	U.S. standardization organization

Abbreviation	Meaning	Explanation
SD	Sensor Defect	Alarm: Sensor failure
SEL	Stop Engine Light	1st function: Warning lamp (stop engine and rectify fault) 2nd function: Read out fault codes
SID	System Identifier	
SPC	Spare Parts Catalog	
SRS	Synchronous Reference Sensor	TDC cylinder 1
SS	Safety System	Indicated alarm is initiated by the safety system
TBS	Turbocharger Boost Sensor	Monitors charge-air pressure
TC	Tools Catalog	
TCI	Turbo Compressor Inlet	
TCO	Turbo Compressor Outlet	
TD	Transmitter Deviation	Alarm: Sensor-comparison failure
TPS	Throttle Position Sensor	
TRS	Timing Reference Sensor	
T-xyz	Temperature-xyz	Temperature measuring point xyz
UT	Unterer Totpunkt	Bottom dead center
VNT	Variable nozzle turbine	
VSG	Variable Speed Governor	
VSS	Vehicle Speed Sensor	

8.4 Index

20V 4000 Gx3 engine data: Continuous operation variable 3B, optimized exhaust emissions (EPA2)	45	Battery-charging generator drive – Drive belt replacement	193
20V 4000 Gx3 engine data: Continuous operation, variable 3B, optimized exhaust emissions (TA-Luft)	49	Battery-charging generator drive – Drive belt tension adjustment	192
20V 4000 Gx3 engine data: Continuous operation, variable 3B, optimized fuel consumption	38	Belt Drive	191
20V 4000 Gx3 engine data: Standby operation 3D, optimized exhaust emissions (EPA stage 2)	34	Drive belt – Condition check	191
20V 4000 Gx3 engine data: Standby operation 3D, optimized fuel consumption	27	Bypassing the safety system (Override)	56
A			
Abbreviations	211	C	
Accessories for Engine Governor (Electronic) / Control System	195	Cabling, General for Engine / Gearbox / Unit	194
Engine governor – Removal and installation	197	Engine wiring – Check	194
Engine governor and connectors – Cleaning	195	Centrifugal oil filter – Cleaning and filter-sleeve replacement	174
Engine governor plug-in connections – Check	196	Charge-air coolant – Change	185
Activities	68, 72	Charge-air coolant – Draining	186
After stopping the engine – engine remains ready for operation	61	Charge-air coolant – Filling	187
After stopping the engine – putting the engine out of service	62	Charge-air coolant – Level check	184
Air Filter	163	Charge-air coolant pump – Relief bore check	190
Air filter – Check	164	Charge-Air Cooling	162
Air filter – Removal and installation	165	Intercooler – Checking condensate drains for coolant discharge and obstructions	162
Air filter replacement	163	Coolant Circuit, General, HT Circuit	176
Air filter – Check	164	Engine coolant – Change	177
Air filter – Removal and installation	165	Engine coolant – Draining	178
Air filter replacement	163	Engine coolant – Filling	179
Air Intake	166	Engine coolant – Sample extraction and analysis	183
Service indicator – Signal ring position check	166	Engine coolant level – Check	176
Air starter – manual operation	167	Engine coolant pump – Relief bore check	182
Auxiliary materials, fire prevention and environmental protection	13	Crankcase Breather	138
B			
Battery-Charging Generator	192	Crankcase breather – Oil separator replacement, diaphragm check and replacement	138
Battery-charging generator drive – Drive belt replacement	193	Crankcase breather – Oil separator replacement, diaphragm check and replacement	138
Battery-charging generator drive – Drive belt tension adjustment	192	Crankshaft transport locking device	08
		Cylinder head cover – Removal and installation	145
		Cylinder Liner	134
		Cylinder liner – Endoscopic examination	134
		Instructions and comments on endoscopic and visual examination of cylinder liners	136
		Cylinder liner – Endoscopic examination	134
		D	
		Drive belt – Condition check	191

E

Emergency stop	60
Engine	131
Engine – Barring manually	131
Engine – Barring with starting system	132
Engine test run	133
Engine – Barring manually	131
Engine – Barring with starting system	132
Engine coolant – Change	177
Engine coolant – Draining	178
Engine coolant – Filling	179
Engine coolant – Sample extraction and analysis	183
Engine coolant level – Check	176
Engine coolant pump – Relief bore check	182
Engine governor – Removal and installation	197
Engine governor ADEC (ECU 7) for Series 4000 genset engines – Fault messages	79
Engine governor and connectors – Cleaning	195
Engine governor plug-in connections – Check	196
Engine layout	17
Engine oil – Change	170
Engine oil – Level check	169
Engine oil – Sample extraction and analysis	172
Engine oil filter – Replacement	173
Engine Overview	17
Engine layout	17
Sensors, actuators and injectors – Overview	19
Engine side and cylinder designations	23
Engine Side and Cylinder Designations	23
Engine side and cylinder designations	23
Engine test run	133
Engine wiring – Check	194

F

Fault messages on the SAM display	78
Final compression pressure	26
Final Compression Pressure	26
Final compression pressure	26
Firing order	25
Firing Sequence	25
Firing order	25
Fuel Filter	153
Fuel filter – Replacement	153

Fuel prefilter – differential pressure check and adjustment of gauge	155
Fuel prefilter – Draining	156
Fuel prefilter – filter element replacement	160
Fuel prefilter – Flushing	158
Fuel prefilter cleaning	154
Fuel filter – Replacement	153
Fuel Injector	146
Injector – Removal and Installation	147
Injector – Replacement	146
Fuel prefilter – differential pressure check and adjustment of gauge	155
Fuel prefilter – Draining	156
Fuel prefilter – filter element replacement	160
Fuel prefilter – Flushing	158
Fuel prefilter cleaning	154
Fuel System	152
Fuel system – Venting	152
Fuel system – Venting	152

G

General conditions	05
--------------------------	----

I

Index	215
Injector – Removal and Installation	147
Injector – Replacement	146
Instructions and comments on endoscopic and visual examination of cylinder liners	136
Intercooler – Checking condensate drains for coolant discharge and obstructions	162

L

LT Circuit	184
Charge-air coolant – Change	185
Charge-air coolant – Draining	186
Charge-air coolant – Filling	187
Charge-air coolant – Level check	184
Charge-air coolant pump – Relief bore check	190
Lube Oil System, Lube Oil Circuit	169
Engine oil – Change	170
Engine oil – Level check	169
Engine oil – Sample extraction and analysis	172

M

Main engine dimensions	24
Main Engine Dimensions	24
Main engine dimensions	24
Maintenance schedule matrix	67, 71

Manufacturer's documentation	209
MTU-contact person/service partner	210

O

Oil Filtration / Cooling	173
Centrifugal oil filter – Cleaning and filter-sleeve replacement	174
Engine oil filter – Replacement	173
Operational checks	58

P

Personnel and organizational require- ments	06
Plant – Cleaning	63
Preface	65, 70
Putting the engine into operation after extended out-of-service-periods (>3 months)	53
Putting the engine into operation after scheduled out-of-service-period	54

S

Safety requirements when working on the engine	10
Sensors, actuators and injectors – Overview	19
Service indicator – Signal ring position check	166
Special tools	199
Standards for warning notices in the publication	15
Start engine in manual mode (testing mode)	55
Starter – Condition check	168
Starting Equipment	167

Air starter – manual operation	167
Starter – Condition check	168

Starting the engine in emergency situations (override mode)	57
Stop engine in manual mode (testing mode)	59

T

Technical Data	27
20V 4000 Gx3 engine data: Continuous operation variable 3B, optimized exhaust emissions (EPA2)	45
20V 4000 Gx3 engine data: Continuous operation, variable 3B, optimized exhaust emissions (TA-Luft)	49
20V 4000 Gx3 engine data: Continuous operation, variable 3B, optimized fuel consumption	38
20V 4000 Gx3 engine data: Standby operation 3D, optimized exhaust emissions (EPA stage 2)	34
20V 4000 Gx3 engine data: Standby operation 3D, optimized fuel consumption	27
Transport	07
Troubleshooting	75

V

Valve clearance – Check and adjustment	141
Valve Gear	140
Cylinder head cover – Removal and installation	145
Valve clearance – Check and adjustment	141
Valve gear – Lubrication	140
Valve gear – Lubrication	140

