

STAMFORD[®]

Installation, Service & Maintenance Manual for HC 4, 5 & 6 AC Generators

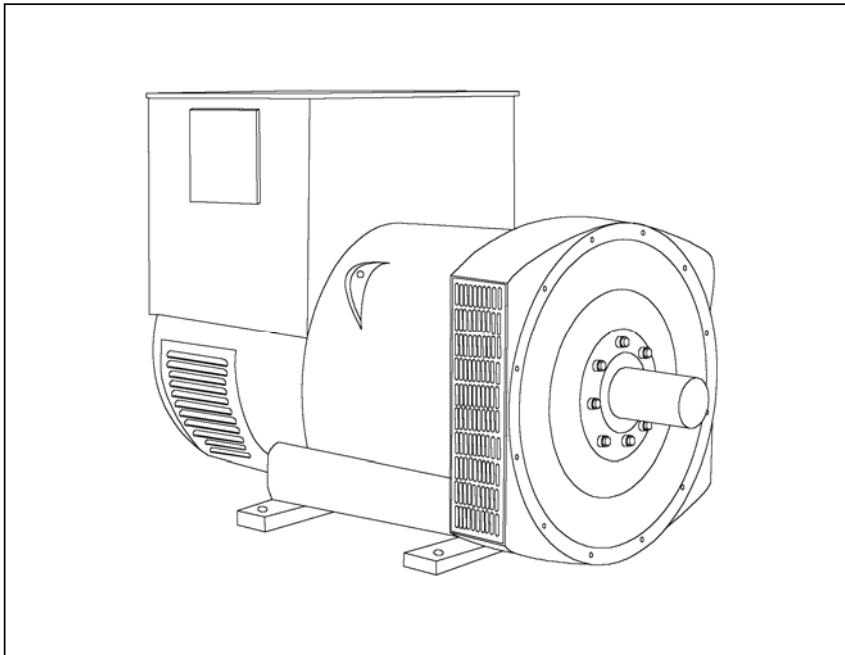

Safety Precautions

First Steps to Safe Operation

Read this manual, obey all Warnings and Cautions, and become familiar with the product.

Warnings & Notices used in this manual

The various warnings are outlined below and appear in the text in this format. Warnings and Cautions appear at the appropriate position in the, to which they refer.

Warning: Information that draws attention to the risk of injury or death.

Caution: Information that draws attention to the risk of damage to the product, process or surroundings.

Note: Used to convey, or draw attention to, additional information or explanations.

Notes appear after the text to which they refer.

Skill requirements of personnel

Service and maintenance procedures should only be carried out by experienced, qualified engineers, familiar with the procedures and the equipment. Before any intrusive procedures are carried out, ensure that the engine is inhibited and the generator is electrically isolated.

Electrical Equipment

All electrical equipment can be dangerous if not operated correctly. Always service and maintain the generator in accordance with this manual. Always use genuine STAMFORD replacement parts.

Warning: Electrical shock can cause injury or death. Ensure that all personnel operating, servicing, maintaining or working near this equipment are fully aware of the emergency procedures in case of accidents.

Before removing the protective covers to carry out service maintenance or repair, ensure that the engine is inhibited and the generator is electrically isolated. The AVR access covers are designed to be removed while the generator is on load.

Lifting

Lift the generator using the points provided with the aid of a spreader and chains. The angle on the chains must be vertical during the lift. Do not lift single bearing generators without the, securely fitted, transit bar. When removing the transit bar just prior to offering the generator up to the engine, be aware that the rotor is not securely held in the generator. Keep the generator in the horizontal plane to when the transit bar is not fitted.

Warning: The lifting points provided are designed for lifting the generator only. Do not lift the Generating Set by the generator's lifting points.

Note: Due to our policy of continuous improvement, details in this manual which were correct at time of going to print and may now be due for amendment. Information included must therefore not be regarded as binding.

Note: The Front Cover drawing is representative of the range of generators. Several variations are available within this range that, are covered by this manual.

Foreword

The Manual

Before operating, the generating set read this manual and all additional documentation supplied with it. Great care has been taken with the design of this product to ensure that it is safe to operate. Misuse and the failure to follow the safety precautions contained in the manual are potential causes of accidents.

Read the manual and make sure that all personnel who work on the equipment have access to the manual. The manual should be considered as part of the product and should remain with the product. Make sure that the manual is available to all users throughout the life of the product.

Scope

This manual contains guidance and instructions for the Installation, Servicing and Maintenance of the generator.

It is not possible, within the scope of the manual, to teach the basic electrical and mechanical skills required to safely carry out the procedures enclosed. The manual is written for skilled electrical and mechanical technicians and engineers, who have prior knowledge and experience of generating equipment of this type.

We offer a range of training courses that cover all aspects of STAMFORD generators.

Generator Designation

HC	(K)	I	5	3	4	C	2	(eg)
HC	-	Standard range Generators						
HCK	-	Dedicated range (not HC6)						
I	-	Applications, M = Marine I = Industrial, K = dedicated.						
5	-	Frame size, 4, 5, or 6						
3	-	Separate excitation, PMG						
or								
4	-	Self Excited						
4	-	Number of poles, 4 or 6						
C	-	Core Size						
2	-	Number of bearings, 1 or 2						

The Product

The product is an AVR controlled, separately excited (by a shaft driven pilot exciter) synchronous 'ac generator' or a self excited (shunt arrangement). Designed for incorporation into a generating-set. (A generating-set is defined as 'machinery' in European directives).

Serial Number Location

Each generator has a unique serial number stamped into the upper section of the drive end of the frame.

The serial number is also shown on the nameplate.

Two other labels are located inside the terminal box, both fixed inside of the terminal box, one on the sheet metal-work and the other on the main frame of the generator. Neither of these two labels is considered to be permanently fixed.

Rating Plate

The generator has been supplied with a self-adhesive rating plate label to enable fitting after final assembly and painting. Stick the nameplate to the outside of the non-drive end of the terminal box. The surface in the area where a label is to be stuck must be flat, clean, and any paint finish must be fully dry before attempting to attach label. Recommended method for attaching label is peel and fold back sufficient of the backing paper to expose some 20 mm of label adhesive along the edge which is to be located against the sheet metal protrusions. Once this first section of label has been carefully located and stuck into position progressively peel off the backing paper and smooth down with a clean cloth. The adhesive will achieve a permanent bond in 24 hours.

A factory fitted metal nameplate is available for some applications.

Caution. Do not exceed the parameters marked on the rating plate.

Contents

SAFETY PRECAUTIONS 2
 FIRST STEPS TO SAFE OPERATION 2
 WARNINGS & NOTICES USED IN THIS MANUAL 2
 SKILL REQUIREMENTS OF PERSONNEL 2
 ELECTRICAL EQUIPMENT 2
 LIFTING 2

FOREWORD 3
 THE MANUAL 3
 SCOPE 3
 GENERATOR DESIGNATION 3
 THE PRODUCT 3
 SERIAL NUMBER LOCATION 3
 RATING PLATE 3

CONTENTSINTRODUCTION 4

INTRODUCTION 8
 GENERAL DESCRIPTION, WITH PMG – SEPARATELY EXCITED 8
 MX341 AVR 8
 MX321 AVR 8
 GENERAL DESCRIPTION WITHOUT PMG – SELF EXCITED 9
 AS440 AVR 9
 MX341 AVR 9
 MX321 AVR 10

STANDARDS 11
 EUROPEAN DIRECTIVES 11
 Applications for use within the EU 11
 Unsuitable Applications 12
 Additional information for EMC compliance 12

APPLICATION OF THE GENERATOR 13
 ENVIRONMENTAL PROTECTION 13
 Air Flow 13
 AIRBORNE CONTAMINATES 13
 Air Filters 13
 HIGH HUMIDITY ENVIRONMENTS 13
 Anti-condensation heaters 13
 Enclosures 13
 VIBRATION 13
 Definition of BS5000 – 3 14
 Definition of ISO 8528 - 9 14
 Vibration Monitoring 14
 Excessive Vibration levels 14
 BEARINGS 14
 Re-greasable Bearings 14
 Bearing Life 15
 Health Monitoring of the Bearings 15
 Bearing 'Service Life' Expectancy 15

INSTALLATION INTO THE GENERATING SET 16
 DELIVERY 16
 HANDLING THE GENERATOR 16
 STORAGE 16
 AFTER STORAGE 16
 ROTOR BALANCING 16
 GENERATOR VIBRATION, FREQUENCY 16
 COUPLING ARRANGEMENTS 17
 Coupling Single Bearing Generators 17

Single Bearing Coupling Alignment.....	17
EARTH ARRANGEMENT	18
PAINT FINISH	18
WARNING LABELS	18
PRE-RUNNING CHECKS.....	18
Insulation resistance test.....	19
DIRECTION OF ROTATION	19
PHASE ROTATION	19
VOLTAGE AND FREQUENCY	19
AVR ADJUSTMENT	19
ACCESSORIES	19
INSTALLATION, ON SITE.....	20
GENERAL	20
CUSTOMER CABLE ENTRY.....	20
EARTH CONNECTIONS.....	20
ELECTRICAL PROTECTION.....	20
VOLTAGE SURGES AND MICRO- INTERRUPTIONS.....	20
SYNCHRONISATION NOTES	21
AUTOMATIC VOLTAGE REGULATORS.....	21
AS440 AVR	21
AS440 AVR	22
INITIAL CHECKS	22
INITIAL START UP	22
Voltage Set Up.....	23
Stability Set Up.....	23
AVR ADJUSTMENTS	23
UNDER FREQUENCY ROLL OFF (UFRO).....	23
EXC TRIP (Excitation Trip)	23
Transient Load Switching.....	23
DIP.	24
SUMMARY OF CONTROLS, MX341	24
AUTOMATIC VOLTAGE REGULATOR TYPE MX321.....	25
INITIAL CHECKS	25
INITIAL START UP	25
Voltage Set Up.....	25
Stability Set Up.....	25
RAMP ADJUSTMENT	26
AVR ADJUSTMENTS.....	26
UNDER FREQUENCY ROLL OFF (UFRO).....	26
EXC TRIP (Excitation Trip)	26
OVER/V (Over Voltage)	27
Transient Load Switching.....	27
DIP.	27
DWELL	27
OVERVOLTAGE DE-EXCITATION CIRCUIT BREAKER.....	27
Resetting The Excitation Breaker.....	27
CURRENT LIMITING	28
Setting Procedure	28
SUMMARY OF CONTROLS, MX321	28
FAULT FINDING, MX321 & MX341 AVRS	29
SEPARATE EXCITATION TEST PROCEDURE.....	29
Checking the Permanent Magnet Generator (PMG).....	29
Checking Generator Windings and Rotating Diodes	29
Check Rectifier Diodes.....	30
Replacement of Faulty Diodes.....	30
Surge Suppressor	30
Main Excitation Windings	30
Unbalanced Main Terminal Voltages	30
EXCITATION CONTROL TEST.....	30
AVR Function Test	30
ACCESSORIES	32
Remote Voltage Adjustment	32

PARALLEL OPERATION	32
Load Sharing	32
Droop	32
Droop Setting Procedure	33
MANUAL VOLTAGE REGULATOR (MVR).....	33
POWER FACTOR CONTROLLER (PFC3).....	34
SERVICE	35
WINDING CONDITION.....	35
New Machines	35
At Generating Set Assembler's Works	35
Generators in Service.....	35
Winding Condition Assessment	35
PROCEDURE FOR INSULATION TESTING.....	36
METHODS OF DRYING OUT GENERATORS	36
Cold Run.....	36
Blown Air Drying.....	36
Short Circuit Method.....	36
TYPICAL DRYING OUT CURVE.....	37
AIR FILTERS	37
Air Filter Cleaning Procedure	38
MAINTENANCE	39
ANTI-CONDENSATION HEATERS.....	39
REMOVAL OF PERMANENT MAGNET GENERATOR (PMG).....	39
Re-assembly.....	39
REMOVAL OF BEARINGS	39
REMOVAL OF THE NON DRIVE END BEARING.....	40
DRIVE END BEARING REMOVAL	40
REMOVAL OF THE MAIN ROTOR	40
REFITTING BEARINGS.....	41
Equipment	41
Preparation	41
Bearing preparation.....	41
Bearing Cartridge	41
Assemble Bearing into Cartridge	41
Assemble Bearing onto Shaft	42
BEARING CAP & FLINGER	42
Re-lubrication pipe	42
Returning To Service.....	42
BEARING MAINTENANCE.....	42
Re-lubrication	42
PARTS IDENTIFICATION HC6	46
SINGLE BEARING GENERATOR.....	46
TWO BEARING GENERATOR.....	47
SPARES AND AFTER SALES SERVICE	48
RECOMMENDED SPARES.....	48
AFTER SALES SERVICE	48
KLUBER ASONIC GHY72 GREASE	48
TECHNICAL DATA	49
Air Flow requirements	49
Winding Resistances.....	49
Main Stator Winding Resistances	49
Coupling disc Torque setting.....	50
Bending Moments	50
Customer output cables	50
Generator internal connections.....	50
Re-lubrication Details for Regreasable Bearings	51
Initial fill for Regreasable Bearings.....	51

Generator Weight.....	51
Recommended Service Parts	51
A.C. GENERATOR WARRANTY	53
WARRANTY PERIOD	53
Defects, After Delivery	53
EXTENSIONS TO THE WARRANTY PERIOD	53
END OF LIFE DISPOSAL.....	54
RECYCLABLE MATERIAL.....	54
ITEMS REQUIRING SPECIALIST TREATMENT.	54
WASTE MATERIAL	54
STAMFORD WORLDWIDE	55

Introduction

General Description, with PMG – Separately Excited

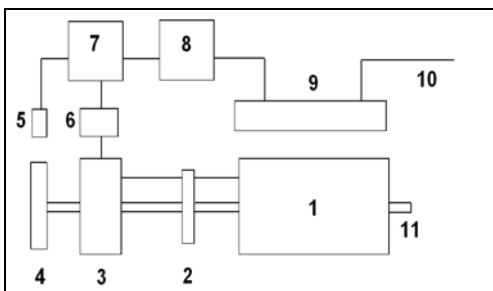

1	Main rotor	7	AVR
2	Rotating diodes	8	Isolating transformer (if fitted)
3	Exciter rotor	9	Main stator
4	PMG rotor	10	Output
5	PMG stator	11	Shaft
6	Exciter stator		

The Permanent Magnet Generator (PMG) provides power for the excitation of the exciter field via the Automatic Voltage Regulator (AVR) which is the controlling device governing the level of excitation provided to the exciter field. The AVR responds to a voltage-sensing signal derived, via an isolating transformer, from the main stator winding. By controlling the low power of the exciter field, control of the high power requirement of the main field is achieved through the rectified output of the exciter armature.

MX341 AVR

The Automatic Voltage Regulator (AVR) is of the thyristor type and forms part of the excitation system for a brushless generator. In addition to regulating the generator voltage, the AVR circuitry includes protective features to ensure safe reliable control of

the generator. Excitation power is derived from a permanent magnet generator (PMG) to guarantee low Radio Frequency Interference (RFI) and immunity from thyristor type loads. The AVR is linked with the main stator windings and controls the power fed to the exciter stator and hence the main rotor to maintain the machine output voltage within the specified limits, compensating for load, speed, temperature and power factor of the generator. Soft start circuitry is included to provide a smooth controlled build up of generator output voltage.

A frequency measuring circuit continually monitors the generator output and provides underspeed protection of the excitation system by reducing the generator output voltage proportionally with speed below an adjustable pre-set threshold. A further enhancement of this feature is an adjustable volts/Hz slope to improve frequency recovery time on turbo charged engines.

Uncontrolled over excitation is limited to a safe period by internal shutdown of the AVR output device.

This condition remains latched until the generator has been stopped. For complete protection, a circuit breaker option is available providing circuit isolation in event of a short circuit power device. In addition it detects engine speed and provides adjustable voltage fall off with speed, below a pre-selected speed (Hz) setting, preventing over-excitation at low engine speeds and softening the effect of load switching to relieve the burden on the engine. It also provides over-excitation protection that acts following a time delay, to de-excite the generator in the event of excessive exciter field voltage.

Provision is made for the connection of a remote voltage trimmer allowing the user fine control of the generator's output. Accessories are available for this AVR. Please refer to factory for further details.

MX321 AVR

In addition to the above the MX321 AVR has 3 phase rms sensing for improved regulation plus:

- Over-voltage protection.
- Adjustable recovery on underspeed protection
- Current limiting may be included to allow control over the amount of short circuit current flowing during three phase and single phase short circuits on the generator output. An additional current transformer is required.

General Description without PMG – Self Excited

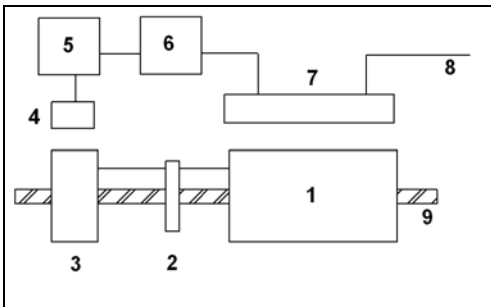

1	Main rotor	6	Isolating transformer (if fitted)
2	Rotating diodes	7	Main stator
3	Exciter rotor	8	Output
4	Exciter stator	9	Shaft
5	AVR		

Power for the excitation system is provided from the main stator output to the AVR to the exciter field. The Automatic Voltage Regulator (AVR) is the controlling device governing the level of excitation provided to the exciter field. The AVR responds to a voltage-sensing signal derived from the main stator winding. By controlling the low power of the exciter field, control of the high power requirement of the main field is achieved through the rectified output of the exciter armature.

AS440 AVR

The AVR senses average voltage on two phases ensuring close regulation. In addition it detects engine speed and provides voltage fall off with speed, below a pre-selected speed (Hz) setting, preventing over-excitation at low engine speeds and softening the effect of load switching to relieve the burden on the

engine. The detailed function of the AVR circuits and their adjustment are covered in the load testing section.

The AS440 AVR also incorporates circuits which, when used in conjunction with accessories, can

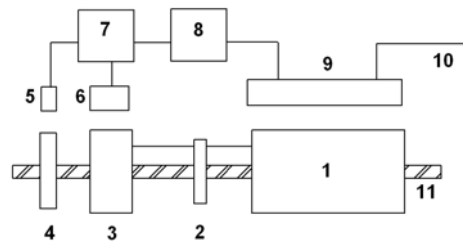

provide for parallel operation with 'droop' control.

The Permanent Magnet Generator (PMG) provides power for the excitation of the exciter field via the Automatic Voltage Regulator (AVR) which is the controlling device governing the level of excitation provided to the exciter field. The AVR responds to a voltage-sensing signal derived, via an isolating transformer, from the main stator winding. By controlling the low power of the exciter field, control of the high power requirement of the main field is achieved through the rectified output of the exciter armature.

MX341 AVR

The Automatic Voltage Regulator (AVR) is of the thyristor type and forms part of the excitation system for a brushless generator. In addition to regulating the generator voltage, the AVR circuitry includes protective features to ensure safe reliable control of the generator. Excitation power is derived from a permanent magnet generator (PMG) to guarantee low Radio Frequency Interference (RFI) and immunity from thyristor type loads. The AVR is linked with the main stator windings and controls the power fed to the exciter stator and hence the main rotor to maintain the machine output voltage within the specified limits, compensating for load, speed, temperature and power factor of the generator. Soft start circuitry is included to provide a smooth controlled build up of generator output voltage.

A frequency measuring circuit continually monitors the generator output and provides underspeed protection of the excitation system by reducing the generator output voltage proportionally with speed

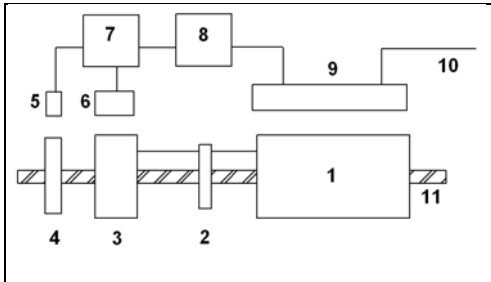

1	Main rotor	7	AVR
2	Rotating diodes	8	Isolating transformer (if fitted)
3	Exciter rotor		
4	PMG rotor	9	Main stator
5	PMG stator	10	Output
6	Exciter stator	11	Shaft

below an adjustable pre-set threshold. A further enhancement of this feature is an adjustable volts/Hz slope to improve frequency recovery time on turbo charged engines.

Uncontrolled over excitation is limited to a safe period by internal shutdown of the AVR output device. This condition remains latched until the generator has been stopped. For complete protection, a circuit breaker option is available providing circuit isolation in event of a short circuit power device. In addition it detects engine speed and provides adjustable voltage fall off with speed, below a pre-selected speed (Hz) setting, preventing over-excitation at low engine speeds and softening the effect of load switching to relieve the burden on the engine. It also provides over-excitation protection that acts following a time delay, to de-excite the generator in the event of excessive exciter field voltage.

Provision is made for the connection of a remote voltage trimmer allowing the user fine control of the generator's output. Accessories are available for this AVR. Please refer to factory for further details.

MX321 AVR

In addition to the above the MX321 AVR has 3 phase rms sensing for improved regulation plus:

- Over-voltage protection.
- Adjustable recovery on underspeed protection
- Current limiting may be included to allow control over the amount of short circuit current flowing during three phase and single phase short circuits on the generator output. An additional current transformer is required.

Standards.

Our AC generators meet the relevant parts of national and international standards pertaining to generators. The generator must be operated within the limits laid down in the relevant standards and within the parameters on the generator rating plate.

Marine generators meet the requirements of all the major marine classification societies.

European Directives.

AC generators sold for use in the European Union must meet the relevant European directives. An ac generator has no intrinsic function; it must be have a mechanic input in order to provide an electrical output. The generator is supplied as a component part of a Generating-Set. To reflect this each generator is supplied with an 'EC Declaration of Incorporation' in accordance the Machinery Directive.

The ac generator meets the relevant directives applicable to an ac generator (component part) before it is incorporated into 'machinery'.

EC DECLARATION OF INCORPORATION	
<p>IN ACCORDANCE WITH THE SUPPLY OF MACHINERY (SAFETY) REGULATIONS 1992 AND THE SUPPLY OF MACHINERY (SAFETY) (AMENDMENT) REGULATIONS 1994 IMPLEMENTING THE EC MACHINERY DIRECTIVE 89/32/EEC AND SUBSEQUENT AMENDMENTS</p>	
<p>THIS STAMFORD A.C. GENERATOR WAS MANUFACTURED BY OR ON BEHALF OF</p>	
<p>NEVAGE INTERNATIONAL LTD BARNACK ROAD, STAMFORD, LINCOLNSHIRE, ENGLAND.</p>	
<p>THIS COMPONENT MACHINERY MUST NOT BE PUT INTO SERVICE UNTIL THE MACHINERY INTO WHICH IT IS TO BE INCORPORATED HAS BEEN DECLARED IN CONFORMITY WITH THE PROVISIONS OF THE SUPPLY OF MACHINERY (SAFETY) REGULATIONS 1995/MACHINERY DIRECTIVE.</p>	
<p>FOR AND ON BEHALF OF THE MANUFACTURER NEVAGE INTERNATIONAL LIMITED</p>	
<p>NAME: POSITION: SIGNATURE:</p>	
<p>THIS COMPONENT MACHINERY CARRIES THE CE MARK FOR COMPLIANCE WITH THE STATUTORY REQUIREMENTS FOR THE IMPLEMENTATION OF THE FOLLOWING DIRECTIVES.</p>	
<p>WARNING i) The EMC Directive 89/36/EEC and subsequent amendments. This Component Machinery shall not be used in the Residential, Commercial and Light Industrial environment unless it also conforms to the relevant standard (EN 50081-1) - REFER TO FACTORY FOR DETAILS ii) The Low Voltage Directive 73/23/EEC and subsequent amendments.</p>	

The directives identified as pertaining to ac generators are:

- The Machinery (Safety) Directive, 98/37/EEC.
- The Low Voltage Directive, 73/23/EEC.
- The EMC Directive, 89/336/EEC

The generator is CE marked; CE labels are supplied loose in case the generating set manufacturer needs to paint the generating set before delivery to the end user.

Note: Once the generator is build into a generating-set (machinery), it is the responsibility of the generating-set manufacture to ensure that the generating-set complies with the relevant EC Directives.

It is contrary to the EC Directives to misrepresent compliance of the EC directives by displaying the CE mark supplied with a component part of the product. The directive requires compliance to be assessed as a component part, as the complete product and during installation on site.

Applications for use within the EU

STAMFORDrators are supplied on the basis that:

- They are used for power generation or related functions.
- They are to be applied in one of the following environments:
 - Portable (open construction – temporary site supply)
 - Portable (enclosed – temporary site supply)
 - Containerised (temporary or permanent site supply)
 - Ship – borne, below decks (marine auxiliary power)
 - Commercial vehicle (road transport / refrigeration etc.)
 - Road transport (auxiliary power)
 - Industrial vehicle (earthmoving, cranes etc.)
 - Fixed installation (Industrial – factory / process plant)
 - Fixed installation (residential, commercial and light industrial – home / office / health.)
 - Energy management (combined heat & power and/or peak lopping.)
 - Alternative energy schemes.
- The standard generators are designed to meet the 'industrial' emissions and immunity standards. Where the generator is required to meet the residential, commercial and light industrial emissions and immunity standards reference must be made document reference N4/X/011. This publication outlines the additional equipment that may be required.
- The installation 'earth/ground' arrangements require the connection of the generator frame to the site protective earth conductor using a minimum lead length.
- Maintenance and servicing with unauthorised parts, will invalidate any liability for EMC compliance.

- Installation, maintenance and servicing are carried out by adequately trained personnel fully aware of the requirements of the relevant EC directives.

Unsuitable Applications

Synchronous generators require a constant speed for power generation. Applications where the generator is not run at a constant speed are not suitable for the standard generator. Such applications may be possible within certain parameters. Contact the factory for advice, there is every possibility that we can provide you with a satisfactory technical solution to meet your requirement.

Additional information for EMC compliance

Standard generators are designed to meet the 'industrial' emissions and immunity standards. Where the generator is required to meet the residential, commercial and light industrial emissions and immunity standards, reference must be made to document reference N4/X/011. This publication outlines the additional equipment that may be required.



Application of the generator

Environmental Protection

Stamford generators are protected to IP23. IP23 is not adequate protection for use outdoors without additional measures.

Ambient Temperature	<40°C
Humidity	<60%
Altitude	<1000m

This table represents the normal operating conditions that the generator is designed for. Operation outside of these parameters is possible after due consideration and will be reflected on the generator nameplate. If the operating environment for the generator

has changed after purchase, the rating of the generator needs to be revised, refer to the factory for details.

Air Flow

The air flow requirements for the generator can be found in the Data section at the back of this manual. Ensure that the air inlets and outlets are not obstructed when the generator is running.

Airborne Contaminates

Contaminates such as salt, oil, exhaust fumes, chemicals, dust, sand, etc., will reduce the effectiveness of the insulation and lead to premature failure of the windings. Consider using air filters or an enclosure to protect the generator.

Air Filters

Air filters are available on request. Filters present a restriction to the airflow so the rating of the generator must be reduced by 5%. If the filters are supplied, factory fitted, the rating on the nameplate will include the reduced rating. The filters can be up-fitted after delivery in which case the customer must apply the power reduction.

Air filters remove airborne particulates above 3 microns. The frequency of changing and cleaning the filters depend on the site conditions. We recommend that the filters are monitored frequently until a suitable cycle of change is established.

Air filters do not remove water. Additional protection must be employed to prevent the filters from getting wet. If the filters are allowed to get wet the airflow will be restricted and the generator will overheat. This will reduce the life expectancy of the insulation leading to premature failure of the generator.

High Humidity environments

The humidity of the air will allow condensation to form on the windings if the temperature of the windings falls below the dew point. The dew point is a relationship between the ambient temperature and humidity. In areas of high humidity additional protection may be required even if the generator is fitted inside an enclosure.

Anti-condensation heaters

Anti-condensation heaters are designed to raise the temperature of the windings above the temperature of the surrounding material so that the condensation will not form on the windings.

We recommend that anti-condensation heaters are fitted to all generators that are left switched off for any period of time. The best practice is to wire the heaters such that the heaters come on when the generator is switched off. This is particularly important in applications where high humidity is a significant problem. Always check the condition of the generators windings before switching the generator on. If moisture is observed carry out one or more of the drying-out methods outlined in the Service section of this manual.

Enclosures

An enclosure should be employed to protect the generator from adverse environmental conditions.

If the generator is to be fitted inside an enclosure, ensure that there is adequate airflow to support both the engine and the generator. Ensure that the generator air supply is clean (free from moisture and contaminants) and at or below the ambient temperature stated on the rating plate.

Vibration

generators are designed to withstand the vibration levels encountered on generating sets built to meet the requirements of ISO 8528-9 and BS 5000-3. (Where ISO 8528 is taken to be broad band measurements and BS5000 refers to the predominant frequency of any vibrations on the generating set).

Definition of BS5000 – 3

Generators shall be capable of continuously withstanding linear vibration levels with amplitudes of 0.25mm between 5Hz and 8Hz and velocities of 9.0mm/s rms between 8 Hz and 200 Hz, when measured at any point directly on the carcass or main frame of the machine. These limits refer only to the predominant frequency of vibration of any complex waveform.

Definition of ISO 8528 - 9

ISO 8528-9 refers to a broad band of frequencies; the broad band is taken to be between 2 Hertz and 300 Hertz. The table below is an example from ISO 8528 - 9 (value 1). This simplified table lists the vibration limits by kVA and speed for acceptable genset operation.

Vibration Levels As Measured On The Generator				
Engine Speed Min ⁻¹	Set Output Kva	Vibration Displacement (<i>S rms</i>)	Vibration Velocity (<i>V rms</i>)	Vibration Acceleration (<i>a rms</i>)
1500 – 1800 (rpm)	>250 kVA	0.32 mm	20 mm/sec	13 m/sec ²
	>1250	0.29 mm	18 mm/sec	11 m/sec ²
The 'Broad band' is taken as 2 Hz - 300 Hz				

Caution: Exceeding either of the above specifications will have a detrimental effect on the life of the bearings and other components. This will invalidate the generator warranty. If you are in any doubt, contact the factory.

Vibration Monitoring

We recommend that the set builder checks the vibration levels using vibration analysing equipment. Ensure that the vibration levels of the generating set are within the levels stated in BS 5000-3 and ISO 8528-9. If the vibration levels are not within tolerance the genset builder should investigate the root cause of the vibrations and eliminate them. The 'best practice' is for the genset builder to take initial readings as a base line and the user to periodically monitor the genset and bearings to detect any deteriorating trend. It will then be possible to plan ahead for bearing changes and eliminate vibration problems before excessive damage to the generating set occurs.

Vibration checks should be made every 3 months.

Excessive Vibration levels

If the vibration levels of the generating set are not within the parameters quoted above:

- Consult the genset builder; the genset builder should address the genset design to reduce the vibration levels as much as possible.
- Discuss, with us the impact of not meeting the above levels on both bearing and generator life expectancy.
- When requested, or it is deemed necessary, we will work with the genset builder in an attempt to find a satisfactory solution.

Bearings

Sealed for life or re-greasable bearings are fitted to the P range of generators. The bearings are fitted within machined housings, these housings form an assembly located and bolted, within the end brackets. All of the have bearings have pressed steel cages and are type C3. The grease used is a high specification synthetic compound that must not be mixed with grease with a different specification.

Re-greasable Bearings

When re-greasable bearings are fitted the bearing housings incorporate fittings for pipework to an external grease nipple. Generators with re-greasable bearings are supplied with information labels advising the user of grease type, re-lubrication frequency, and the quality of grease to be used. These instructions must be followed. The information is repeated in the Data section of this manual. The bearing housing has a grease escapement slot at the bottom of the outer area. At the drive end the grease, expelled from the escapement slot, will discharge into the coupling area. At the non-drive end the grease, from escapement slot, is deflected by a metal plate to ensure that it cannot foul the Permanent Magnet Generator (PMG). The sheet metal cover over the PMG has a slot at the bottom to enable the excess grease to escape.

Bearing Life

Factors that effect bearing life:

The life of a bearing in service is subject to the working conditions and the environment:

- High levels of vibration from the engine or misalignment of the set will stress the bearing and reduce its service life. If the vibration limits set out in BS 5000-3 and ISO 8528-9 are exceeded bearing life will be reduced. Refer to 'Vibration' below.
- Long stationary periods in an environment where the generator is subject to vibration can cause false brinnelling, which puts flats on the balls and grooves on the races, leading to premature failure.
- Very humid atmospheric or wet conditions can emulsify the grease causing corrosion and deterioration of the grease, leading to premature failure of the bearings.

Health Monitoring of the Bearings

We recommends that the user check the bearing condition, using monitoring equipment, to determine the state of the bearings. The 'best practice' is to take initial readings as a base line and periodically monitor the bearings to detect a deteriorating trend. It will then be possible to plan a bearing change at an appropriate generating set or engine service interval.

Bearing 'Service Life' Expectancy

Bearing manufacturers recognise that the "service life" of their bearings is dependent upon many factors that are not in their control; they cannot therefore quote a "service life".

Although "service life" cannot be guaranteed, it can be maximised by attention to the generating set design. An understanding of the generating set's application will also help the user to maximise the service life expectancy of the bearings. Particular attention should be paid to the alignment, reduction of vibration levels, environmental protection, maintenance and monitoring procedures.

We do not quote life expectancy figures for bearings, but suggests practicable replacement intervals based on the L10 life of the bearing, the type of grease and the recommendations of the bearing and grease manufacturers.

For general-purpose applications: providing the correct maintenance is carried out, vibration levels do not exceed the levels stated in ISO 8528-9 and BS5000-3, and the ambient temperature does not exceed 50°C. Plan to replace re-greaseable bearing within 40,000 hours and sealed for life bearing within 30,000 hours of operation. (This estimate is based on the use of Kluber Asonic GHY 72 grease only.) (In theory any grease with an equivalent specification would achieved a similar performance).

It is important to note that bearings in service, under good operating conditions, can continue to run beyond the recommended replacement period. It should also be remembered that the risk of bearing failure increases with time.

If in doubt about any aspect of the 'bearing life' on generators, contact your nearest Stamford supplier.

Installation into the Generating Set

The generator is supplied as a component part for installation into a 'generating set'.

Delivery

Upon receipt of the generator, check the generator for damage that may have occurred during transport. Also check that the rating-plate details are correct and as ordered for the application.

Handling the generator

When lifting the generator use a spreader bar to ensure that the angle on the lifting chains are vertical to the lifting position on the generator.

Warning: The generator lifting points are designed to lift the generator only. Do not lift the complete generating set by the generator lifting points.

Single bearing generators have a transit bar fitted at the drive end. This bar holds the rotor in position during transit. The transit bar should be left in position until it is necessary to remove it to allow the generator to be coupled to the engine.

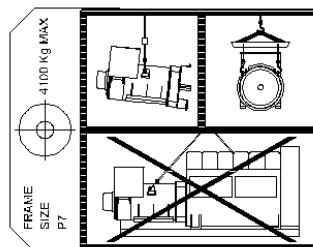

Warning: If the generator is moved without the transit bar be aware that the rotor could fall out of the frame. When moving the generator always keep it in the horizontal plane, this will reduce the risk of the rotor falling out.

Storage

If the generator is not to be used immediately, it must be stored in a clean, dry, vibration free environment. If anti-condensation heaters are fitted, switch them on. If heaters are not fitted use other means to ensure that condensation cannot form on the windings. Spin the shaft by hand every month to prevent flat spots in the bearings and to free up the grease.

After Storage

After a period of storage, carry out 'pre running checks' to determine the condition of the windings. If the winding are damp or the insulation is low, follow one of the 'drying out procedures', in the Service section of this manual. If the generator has re-greasable bearings and has been in storage for 6 months or more, re-lubricate the bearings before use. If the bearings are sealed for life, replace the bearing after 12 months in storage. (see the Maintenance section)

Rotor balancing

Dynamic balancing of the generator rotor assembly has been carried out during manufacture in accordance with BS 6861 Part 1 Grade 2.5 to ensure vibration limits of the generator are in accordance with BS 4999 Part 142.

Generator Vibration, Frequency

The main vibration frequencies produced by the component generator are as follows:

1500 rpm	25 Hz
1800 rpm	30 Hz
1000 rpm	16.7Hz
1200 rpm	20Hz

However, vibrations induced by the engine are complex and contain frequencies of 1.5, 3, 5 or more times the fundamental frequency of vibration. These induced vibrations can result in generator vibration

levels higher than those derived from the generator itself. It is the responsibility of the generating set designer to ensure that the alignment and stiffness of the bedplate and mountings are such that the vibration limits of BS5000 part 3 and ISO 8528 part 9 are not exceeded.

In standby applications where the running time is limited and reduced life expectancy is accepted, higher levels than specified in BS5000 part 3 can be tolerated, up to a maximum of 18mm/sec.

Coupling arrangements

Single and two bearing arrangements are available both arrangements can be close coupled. Both arrangements also need a firm level foundation.

Two bearing generators require a substantial bedplate with engine/generator mounting pads to ensure a good base for accurate alignment. Close coupling of the engine to the generator can increase the overall rigidity of the set. A flexible coupling, designed to suit the specific engine/generator combination, is recommended to minimise the torsional effects.

Accurate alignment of single bearing generators is essential, vibration can occur due to the flexing of the flanges between the engine and generator. A substantial bedplate with engine/generator mounting pads is required.

For the purposes of establishing set design the bending moment at the engine flywheel housing to generator adaptor interface should not exceed 140 kgm (1000 ft.lbs) for the frame 4& 5 and 275 kgm. (2000ft.lbs.) for the frame 6

The maximum bending moment of the engine flange must be checked with the engine manufacturer.

Torsional vibrations occur in all engine-driven shaft systems and may be of a magnitude to cause damage at certain critical speeds. It is therefore necessary to consider the torsional vibration effect on the generator shaft and couplings.

It is the responsibility of the generator set manufacturer to ensure compatibility, and for this purpose drawings showing the shaft dimensions and rotor inertias are available for customers to forward to the engine supplier. In the case of single bearing generators coupling details are included.

Caution: Torsional incompatibility and/or excessive vibration levels can cause damage or failure of the generator and/or engine components.

Coupling Two Bearing Generators

A flexible coupling should be fitted and aligned in accordance with the coupling manufacturer's instruction.

If a close coupling adaptor is used the alignment of machined faces must be checked by offering the generator up to the engine. Shim the generator feet if necessary. Ensure adaptor guards are fitted after generator/engine assembly is complete. Open coupled sets require a suitable guard, to be provided by the set builder.

Axial loading of the generator bearings should be avoided. Should it be unavoidable contact the factory for advice.

Warning: Incorrect guarding and/or generator alignment can result in injury and/or equipment damage.

Coupling Single Bearing Generators

Alignment of single bearing generators is critical. If necessary, shim the generator feet to ensure alignment of the machined surfaces.

For transit and storage purposes the generator frame spigot and rotor coupling plates have been coated with a rust preventative. This MUST BE removed before assembly to engine.

A practical method for removal of this coating is to clean the mating surface areas with a de-greasing agent based on a petroleum solvent.

Warning: Care should be taken not to allow any cleaning agent to come into prolonged contact with skin.

Single Bearing Coupling Alignment

1. On the engine check the distance from the coupling mating face on the flywheel to the flywheel housing mating face. This should be within 0.5mm of nominal dimension. This is necessary to ensure

- that a thrust is not applied to the ac generator bearing or engine bearing.
2. Check that the bolts securing the flexible plates to the coupling hub are tight and locked into position. Refer to the Data section of the manual for tightening torques.
 3. Remove air outlet covers from the drive end of the generator to gain access to coupling and adaptor bolts. Check that coupling joint interfaces are clean and lubricant free.
 4. Check that coupling discs are concentric with adaptor spigot. This can be adjusted by the use of tapered wooden wedges between the fan and adaptor. Alternatively the rotor can be suspended by means of a rope sling through the adaptor opening.
 5. Consider using alignment studs to ensure that the disc and the flywheel are in alignment.
 6. Offer the generator to engine and engage both coupling discs and housing spigots at the same time, pushing generator towards engine until coupling discs are against flywheel face, and the housing spigots are located.

Caution: Do not pull the generator to the engine using bolts through the flexible discs.

7. Fit housing and coupling bolts taking care to use heavy gauge washers between coupling bolt head and coupling disc. Tighten bolts evenly around assembly sufficiently to ensure correct alignment.
8. Tighten housing bolts.
9. Tighten coupling disc to flywheel bolts. Refer to engine manufacturer's manual for correct tightening torque.
10. Remove rotor aligning aids, the sling, or wooden wedges and replace all covers.

Caution: Incorrect generator alignment can result in damage to the generator.

Warning: Failure to replace protective covers can result in injury.

Earth arrangement

The generator frame should be solidly bonded to the generating set bedplate. If anti-vibration mounts are fitted between the generator frame and its bedplate a suitably rated earth conductor (normally one half of the cross sectional area of the main line cables) should bridge across the anti-vibration mounts.

Warning: Refer to local regulations to ensure that the correct earth requirements are incorporated in the installation. Inadequate earth installations put lives at risk.

Paint Finish

Unless previous arrangements have been agreed, the generator will be supplied in a water based primer coat. It is expected that the generating set assembler will want to paint the generating set with a final coat in their company livery.

Note: The primer coat is not adequate protection for many applications without additional protection.

Warning labels

As we expect the set builder to paint the generator in his own livery we supply the warning labels loose. The labels can be found in a wallet attached to the generator together with this manual.

Use the labels as per the instructions printed on the reverse of the labels.

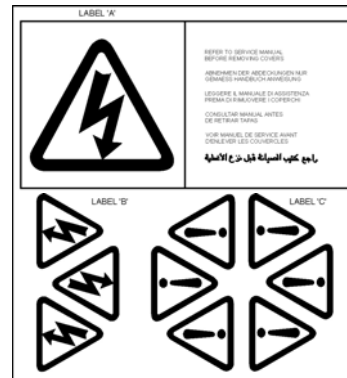

Pre-Running Checks

Before starting the generating set.

- Test the insulation resistance of windings.
- Check all connections are in the correct location and tight

- Check the generator air path is clear of obstructions
- Replace all covers.

Insulation resistance test

The AVR should be disconnected during this test.

A 500V Megger or similar instrument should be used. Disconnect any earth conductor connected between neutral and earth and megger an output lead terminal U, V or W to earth. The insulation resistance reading should be in excess of 5 Megohm to earth. Should the insulation resistance be less than 5 Megohm the winding must be dried out. See the Service section of this Manual.

Caution: The windings have been H.V. tested during manufacture and further H.V. testing may degrade the insulation with consequent reduction in operating life. Should it be necessary to demonstrate H.V. testing, for customer acceptance, the tests must be carried out at reduced voltage levels i.e.

Test Voltage= 0.8 (2 X Rated Voltage + 1000)

Direction of Rotation

The direction of rotation of the generator is designed to be clockwise as viewed from the drive end of the generator.

Phase Rotation

The output from the generator will have a phase sequence of U V W with the generator running clockwise as viewed from the drive end. If the phase rotation of the generator has to be reversed the customer must rearrange the output cables to a UVW configuration. Ask for a circuit diagram of 'reverse phase connections'.

Voltage and Frequency

Check that the voltage and frequency levels required for the generating set application are as indicated on the generator nameplate.

AVR adjustment

To make AVR selections and adjustments remove the AVR cover. Use the tool provided to make adjustments to the AVR settings. The AVR is factory set and will give satisfactory performance during initial running tests. Subsequent voltage adjustment both on and off load may be required. Guidance can be found in the section for the relevant AVR.

Accessories

If there are accessories for control panel mounting supplied with the generator refer to the specific accessory fitting procedures inserted inside the back cover of this book.

Installation, On Site

General

The extent of site installation will depend upon the generating set build, e.g. if the generator is installed in a canopied set with integral switchboards and circuit breaker, on site installation will be limited to connecting up the site load to the generating set output terminals. In this case reference should be made to the generating set manufacturer's instruction book and any pertinent local regulations.

If the generator has been installed on a set without switchboard or circuit breaker the following points relating to connecting up the generator should be noted.

Customer cable entry

The terminal box can accept cable entry from either side. Both panels are removable for drilling/punching to suit glands/or gland boxes. If single core cables are taken through the terminal box side panel a non-magnetic gland plate should be fitted.

Caution: To avoid the possibility of debris entering the generator, remove the panel before drilling.

Incoming cables should be supported from either below or above the box level and at a sufficient distance from the centre line of the generating set so as to avoid a tight radius at the point of entry into the terminal box panel, and allow movement of the generator set on its anti-vibration mountings without excessive stress on the cable.

Before making final connections, test the insulation resistance of the windings.

A 500V Megger or similar instrument should be used. Should the insulation resistance be less than 5.0 Megohm the windings must be dried out as detailed in the Service section of this manual.

Clean the mating surfaces and lightly abrade the mating surfaces, do not score the surface. The current carrying surfaces must connect face to face.

Earth Connections

The neutral of the generator is not bonded to the generator frame when it is supplied from the factory. An earth terminal is provided inside the terminal box adjacent to the main terminals. Should it be required to operate with the neutral earthed a substantial earth conductor (normally equivalent to one half of the section of the line conductors) must be connected between the neutral and the earth terminal provided inside the terminal box. It is the responsibility of the generating set builder to ensure the generating set bedplate and generator frame are all bonded to the main earth terminal in the terminal box.

Caution: Reference should be made to local rules and regulations concerning earth requirements and ensure they are followed.

Electrical Protection

It is the responsibility of the end user and his contractors/sub-contractors to ensure that the overall system protection meets the needs of any inspectorate, local electricity authority or safety rules, pertaining to the site location.

To enable the system designer to achieve the necessary protection and/or discrimination, fault current curves are available on request from the factory, together with generator reactance values to enable fault current calculations to be made.

Warning: Incorrect installation and/or protective systems can result in injury and/or equipment damage. Installers must be qualified to perform electrical installation work.

Adequate electrical protection should be provided so that there will be no danger to personnel, danger of fire or damage to the generator under fault conditions.

Voltage Surges and Micro- Interruptions.

Precautions should be taken to prevent transient voltages generated by the connected load and/or the distribution system from causing damage to the generator components.

To identify any possible risk, all aspects of the generator’s proposed application should be considered, especially the following:-

- Loads with characteristics that result in large load step changes.
- Load control by Switchgear, and power control by any method likely to generate transient voltage spikes.
- Distribution systems susceptible to external influences, such as overhead lines and lightning strikes.
- Applications involving parallel operation to a mains supply, where the risk of a mains disturbance in the form of a micro-interruption could occur.

If the generator is at risk of voltage surges or micro-interruptions adequate protection must be incorporated into the generation system. This is normally in the form of surge arrestors and suppressors.

Synchronisation notes

- The synchronising switch/breaker should be of a type that will not cause “contact bounce” when it operates.
- The synchronising switch/breaker should be adequately rated to withstand the continuous full load current of the generator.
- The switch/breaker should be able to withstanding the rigorous closing cycles during synchronising and the currents produced if the generator is parallel out of synchronism.
- The closing time of the synchronising switch/breaker should be under the control of the synchroniser settings.
- The switch/breaker should be capable of operation under fault conditions such as short circuits. Generator data sheets are available to help calculate this level.

Note: The fault level may include a contribution from other generators as well as from the grid/mains utility.

- The method of synchronising should be either automatic, or by check synchronising. The use of manual synchronising is not recommended.
- The settings on the synchronising equipment should be such that the generator will close smoothly.

Voltage difference	+/- 0.5%
Frequency difference	0.1 Hz/sec
Phase angle	+/- 10°
C/B closing time	50 ms
The Phase sequence must match	

The settings for the synchronising equipment to achieve this must be within these parameters. The voltage difference when paralleling with the grid/mains utility is +/- 3% .

Automatic Voltage Regulators

AS440 AVR

AS440 AVR

The AVR senses average voltage on two phases ensuring close regulation. In addition it detects engine speed and provides voltage fall off with speed, below a pre-selected speed (Hz) setting, preventing over-excitation at low engine speeds and softening the effect of load switching to relieve the burden on the engine. The detailed function of the AVR circuits and their adjustment are covered in the load testing section.

- 8 & Z2 linked for normal remove for auxiliary winding
- Output Voltage adjustment
- Hand trimmer link when not used
- Low voltage selection (110v)
- Droop adjustment
- To optimise analogue input sensitivity
- Excitement trip cut off adjustment
- Stability control
- UFRO adjustment
- Stability section
- Frequency section

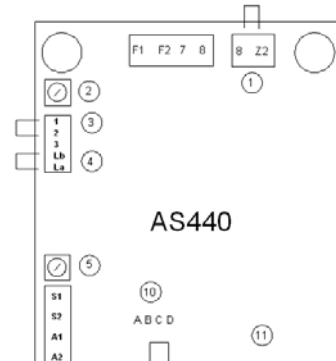

No.	Power range	Response
B-D	< 100kW	Slow
A-C	< 100kW	Fast
B-C	100-550kW	Fast

The MX341 AVR is powered by a 'shaft mounted Permanent Magnet Generator (PMG), Pilot Exciter. The PMG forms part of the separate excitation system for the STAMFORD synchronous, brushless, generator.

Initial Checks

The following 'jumper' connections must be in the correct position for the correct number of poles and the operating frequency of the generator.

Frequency selection terminals	
4 pole 50Hz	LINK 2-3
4 pole 60Hz	LINK 1-3
Stability selection terminals	
Excitation Interruption Link	K1-K2

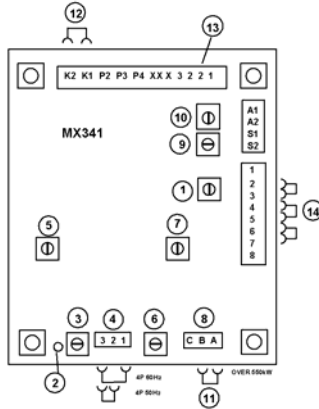

1	Volts	8	Stability section
2	Indicator led	9	Droop
3	UFRO	10	Trim
4	Frequency	11	Link (over 550kW)
5	Dip	12	Isolation link
6	Stability	13	2 x pin 2 use either
7	Excitation trip	14	Std. sensing links

Initial Start Up

On completion of generating set assembly and before starting the generating set, ensure that all of the engine manufacturer's pre-running procedures have been completed, and that adjustment of the engine governor is such that the generator will not be subjected to speeds in excess of 125% of the rated speed.

Caution: Over-speeding the generator during initial setting of the speed governor can result in damage to the generator rotating components.

Voltage Set Up

The voltage is factory set as per the rating plate. If necessary adjust the voltage to the no load level as required.

To adjust the voltage remove the AVR access cover plate, use the insulated tool supplied.

Stability Set Up

The STABILITY control potentiometer is pre-set and should not normally require adjustment. If adjustment is necessary proceed as follows:

- Run the generating set on no-load and check that speed is correct and stable.
- Turn the STABILITY control potentiometer clockwise, and then turn slowly anti-clockwise until the generator voltage starts to become unstable. The correct setting is slightly clockwise from this position (i.e. where the machine volts are stable but close to the unstable region).

AVR adjustments

Having adjusted VOLTS and STABILITY during the initial start-up procedure the other AVR control functions should not require adjustment. If instability on load is experienced, recheck STABILITY setting.

If poor performance is experienced refer to the following paragraphs on each function:

Check that the symptoms indicate that adjustment is necessary.

Make the necessary adjustments.

Under Frequency Roll Off (UFRO)

The AVR incorporates an underspeed protection circuit which gives a voltage/speed (Hz) characteristic as shown:

The UFRO control potentiometer sets the "knee point" [1].

- Symptoms of incorrect setting are
- a) The light emitting diode (LED) indicator permanently lit when the generator is on load
 - b) Poor voltage regulation on load, i.e. operation on the sloping part of the characteristic [2].

Clockwise adjustment lowers the frequency (speed) setting of the "knee point" and extinguishes the LED. For optimum setting the LED should illuminate as the frequency falls just below nominal frequency, i.e. 47Hz on a 50Hz generator or 57Hz on a 60Hz generator.

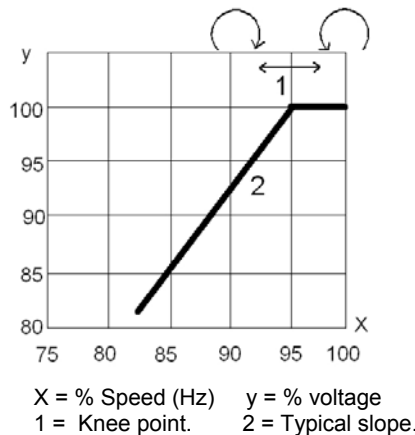

Caution: If the LED is illuminated and no output voltage is present, refer to EXC TRIP and/or OVER/V sections below.

EXC TRIP (Excitation Trip)

An AVR supplied from a permanent magnet generator inherently delivers maximum excitation power on a line to line or line to neutral short circuit. In order to protect the generator windings the AVR incorporates an over excitation circuit which detects high excitation and removes it after a pre-determined time, (10 seconds).

Symptoms of incorrect setting are the generator output collapses on load or small overload, and the LED is permanently illuminated.

The correct setting is 70 volts +/- 5% between terminals X and XX.

Transient Load Switching

The additional function controls of DIP and DWELL are provided to enable the load acceptance capability of the generating set to be optimised. The overall generating set performance depends upon the engine capability and governor response, in conjunction with the generator characteristics.

It is not possible to adjust the level of voltage dip or recovery independently from the engine performance, and there will always be a 'trade off' between frequency dip and voltage dip.

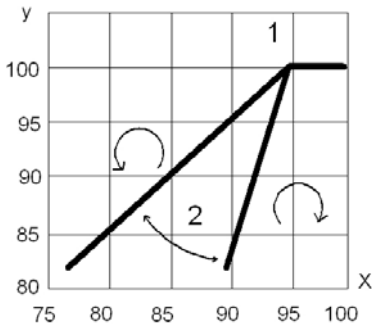

DIP.

The dip function control potentiometer adjusts the slope of the voltage/speed (Hz) characteristic below the knee point as shown below:

- X = % Speed (Hz)
- y = % voltage
- 1 = Knee point
- 2 = Adjustable slope

Summary of Controls, MX341

Control	Function	Direction
Volts	To adjust generator output voltage	Clockwise increases output voltage
Stability	To prevent voltage hunting	Clockwise increases stability or damping effect
UFRO	To set under frequency roll off knee point	Clockwise reduces knee point frequency
Droop	To set generator droop to 5% at full load 0 PF	Clockwise increases the droop
V/Trim	To match AVR input to accessory output	Clockwise allows the accessory more control over
Exc Trip	To set the over excitation cut off level	Clockwise increases the cut off level
Dip	To set the initial frequency related voltage dip	Clockwise increases the voltage dip

Automatic Voltage Regulator Type MX321

The MX321 is the most sophisticated AVR in the STAMFORD range. Powered by a 'shaft mounted Permanent Magnet Generator (PMG), Pilot Exciter' it forms part of the separate excitation system for the brushless generator.

Initial Checks

The following 'jumper' connections must be in the correct position for the correct number of poles and the operating frequency of the generator.

MX321 jumper connections	
Frequency selection terminals	
4 pole 50Hz operation	LINK 2-3
4 pole 60Hz operation	LINK 1-3
Stability selection terminals	LINK A-B
Excitation Interruption Link	K1-K2

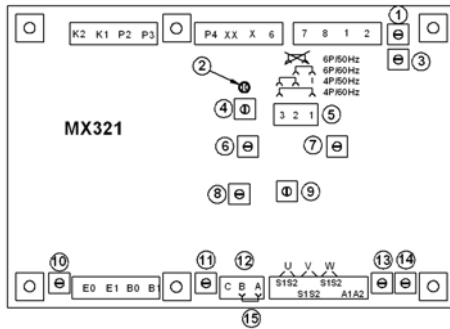

1	Volts	9	Stability
2	Indicator led	10	Over/v
3	I/limit	11	Exc trip
4	UFRO	12	Stability selector
5	Frequency selector	13	Droop
6	Dip	14	Trim
7	rms	15	Link (over 550kW)
8	Dwell		

Initial Start Up

On completion of generating set assembly and before starting the generating set, ensure that all of the engine manufacturer's pre-running procedures have been completed, and that adjustment of the engine governor is such that the generator will not be subjected to speeds in excess of 125% of the rated speed.

Caution: Overspeeding the generator during initial setting of the speed governor can result in damage to the generator rotating components.

Voltage Set Up

The voltage is factory set as per the rating plate. If necessary adjust the voltage to the no load level as required.

To adjust the voltage remove the AVR access cover plate, use the insulated tool supplied.

Stability Set Up

The STABILITY control potentiometer is pre-set and should not normally require adjustment. If adjustment is necessary proceed as follows:

- Run the generating set on no-load and check that speed is correct and stable.
- Turn the STABILITY control potentiometer clockwise, then turn slowly anti-clockwise until the generator voltage starts to become unstable.

Note: The correct setting is slightly clockwise from this position (i.e. where the machine volts are stable but close to the unstable region).

Ramp Adjustment

The AVR includes a soft start circuit to control the rate of voltage build-up when the generator runs up to speed. This is normally pre-set to give a voltage ramp-up time of approximately three seconds. If required, this can be adjusted between the limits defined in the specification.

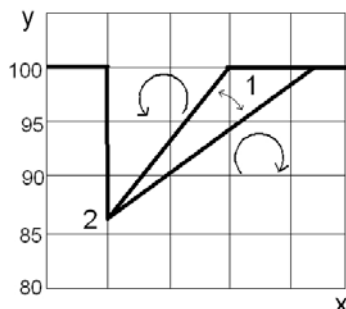

With the [RAMP] control fully counter-clockwise the AVR ramp time is approximately 0.5s. With the [RAMP] control fully clockwise the value is extended to approximately 4.0s.

X = % Voltage y = time
1 = Adjustable slope 2 = Instant of load application

AVR Adjustments

Having adjusted VOLTS and STABILITY during the initial start-up procedure, other AVR control functions should not normally need adjustment. If instability on load is experienced, recheck stability setting. If however, poor performance is experienced, refer to the following paragraphs on each function to:

- Check that the symptoms observed do indicate adjustment is necessary.
- Make the necessary adjustments.

Under Frequency Roll Off (UFRO)

The AVR incorporates an underspeed protection circuit which gives a voltage/speed (Hz) characteristic as shown:

The UFRO control potentiometer sets the "knee point" [1]. Symptoms of incorrect setting are

- The light emitting diode (LED) indicator permanently lit when the generator is on load
- Poor voltage regulation on load, i.e. operation on the sloping part of the characteristic [2].

Clockwise adjustment lowers the frequency (speed) setting of the "knee point" and extinguishes the LED. For Optimum setting the LED should illuminate as the frequency falls just below nominal frequency, i.e. 47Hz on a 50Hz generator or 57Hz on a 60Hz generator.

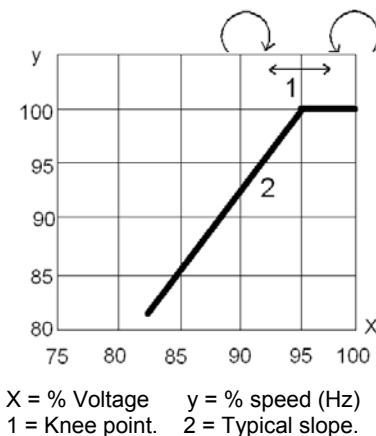

X = % Voltage y = % speed (Hz)
1 = Knee point. 2 = Typical slope.

Caution: If the LED is illuminated and no output voltage is present, refer to EXC TRIP and/or OVER/V sections below.

EXC TRIP (Excitation Trip)

An AVR supplied from a permanent magnet generator inherently delivers maximum excitation power on a line to line or line to neutral short circuit. In order to protect the generator windings the AVR incorporates an over excitation circuit which detects high excitation and removes it after a pre-determined time, i.e. 8-10 seconds.

Symptoms of incorrect setting are the generator output collapses on load or small overload, and the LED is permanently illuminated.

The correct setting is 70 volts +/- 5% between terminals X and XX.

OVER/V (Over Voltage)

Over voltage protection circuitry is included in the AVR to remove generator excitation in the event of loss of AVR sensing input. The AVR has both internal electronic de-excitation and provision of a signal to operate an external circuit breaker.

The correct setting is 300 volts +/-5% across terminals E1, E0.

Clockwise adjustment of the OVER/V control potentiometer will increase the voltage at which the circuit operates.

Transient Load Switching

The additional function controls of DIP and DWELL are provided to enable the load acceptance capability of the generating set to be optimised. The overall generating set performance depends upon the engine capability and governor response, in conjunction with the generator characteristics.

It is not possible to adjust the level of voltage dip or recovery independently from the engine performance, and there will always be a 'trade off' between frequency dip and voltage dip.

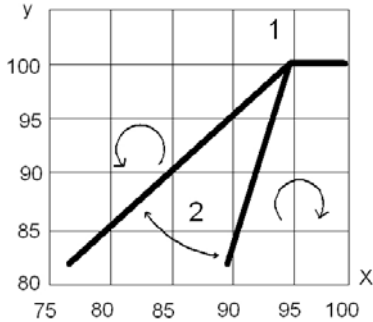

DIP.

The dip function control potentiometer adjusts the slope of the voltage/speed (Hz) characteristic below the knee point as shown below:

- X = % Voltage
- Y = % speed (Hz)
- 1 = Knee point
- 2 = Adjustable slope

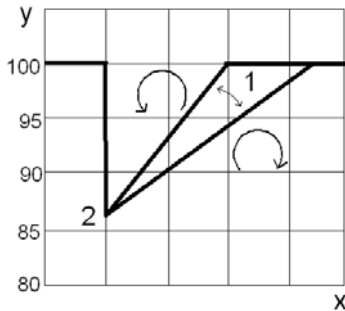

DWELL

The dwell function introduces a time delay between the recovery of voltage and recovery of speed.

The purpose of the time delay is to reduce the generator kW below the available engine kW during the recovery period, thus allowing an improved speed recovery.

Again this control is only functional below the "knee point", i.e. if the speed stays above the knee point during load switching there is no effect from the DWELL function setting.

- X = % Voltage
- y = % speed (Hz)
- 1 = Adjustable slope
- 2 = Instant of load application

Overvoltage De-Excitation Circuit Breaker

This accessory provides positive interruption of the excitation power in the event of overvoltage due to loss of sensing or internal AVR faults including the output power device.

With the MX321 AVR this accessory is supplied loose for fitting in the control panel.

Caution: When the Circuit Breaker is supplied loose, terminals K1&K2 at the auxiliary terminal block are fitted with a link to enable operation of the AVR. When connecting the circuit breaker this link must be removed.

Resetting The Excitation Breaker

In the event of operation of the circuit breaker, indicated by loss of generator output voltage, manual resetting is required. When in the "tripped" state the circuit breaker switch lever shows "OFF". To reset move the switch lever to the position showing "ON".

Warning: Terminals, which are LIVE with the generating set running, are exposed when the AVR access cover is removed. Resetting of the circuit breaker must be carried out with the generating set stationary, and engine starting circuits disabled.

When fitted in the generator, access to the breaker is gained by removal of the AVR access cover. The circuit breaker is mounted on the AVR mounting bracket either to the left or to the right of the AVR depending upon AVR position. After resetting the circuit breaker replace the AVR access cover before restarting the generating set.

Current Limiting

This accessory works in conjunction with the MX321AVR circuits to provide an adjustment to the level of current delivered into a fault. One current transformer (CT) per phase is fitted to provide current limiting on any line to line or line to neutral fault. Note: The W phase CT can also provide "DROOP". Refer to 'Droop', for setting droop independent of current limit. Adjustment means is provided with the "/LIMIT" control potentiometer on the AVR. If current limit transformers are supplied with the generator the limit will be set in accordance with the level specified at the time of order, and no further adjustment will be necessary. However, should the level need to be adjusted, refer to the setting procedure.

Setting Procedure

Run the generating set on no-load and check that engine governor is set to control nominal speed.

Stop the generating set. Remove the link between terminals K1-K2 at the auxiliary terminal block and connect a 5A switch across the terminals K1-K2.

Turn the "/LIMIT" control potentiometer fully anticlockwise. Short-circuit the stator winding with a bolted 3 phase short at the main terminals. An AC current clip-on ammeter is required to measure the winding lead current.

With the switch across K1-K2 open start the generating set.

Close the switch across K1& K2 and turn the "/LIMIT" control potentiometer clockwise until required current level is observed on the clip-on ammeter. As soon as correct setting is achieved open the K1& K2 switch.

Should the current collapse during the setting procedure, the internal protective circuits of the AVR will have operated. In this event shut down the set and open the K1&K2 switch. Restart the set and run for 10 minutes with K1&K2 switch open, to cool the generator windings, before attempting to resume the setting procedure.

Caution: Failure to carry out the correct COOLING procedure may cause overheating and consequent damage to the generator windings

Summary of Controls, MX321

Control	Function	Direction
Volts	To adjust generator output voltage	Clockwise increases output voltage
Stability	To prevent voltage hunting	Clockwise increases stability or damping effect
UFRO	To set under frequency roll off knee	Clockwise reduces knee point frequency
Droop	To set generator droop to 5% at full	Clockwise increases the droop
V/Trim	To match AVR input to accessory	Clockwise allows the accessory more control
Exc Trip	To set the over excitation cut off level	Clockwise increases the cut off level
Dip	To set the initial frequency related	Clockwise increases the voltage dip
I Limit	To set the maximum short cct. current	Clockwise increases the short circuit current
Dwell	To set under frequency recovery	Clockwise increases the recovery time

Fault Finding, MX321 & MX341 AVRs

Warning: Fault finding procedures present hazards, which can result in injury or death. Only personnel qualified to perform electrical and mechanical service should carry out these procedures. Ensure engine-starting circuits are disabled before commencing service or maintenance procedures. Isolate any anti-condensation heater supply.

Note: Before commencing any fault finding procedures examine all wiring for broken or loose connections.

No voltage build-up when starting set	1) Check link K1&K2 on auxiliary terminals. Follow Separate Excitation Test Procedure to check machine and AVR.
Voltage very slow to build up	Check setting of ramp potentiometer. MX321 only
Loss of voltage when set running	First stop and restart set. If no voltage or voltage collapses after short time, follow Separate Excitation Test Procedure.
Generator Voltage high followed by collapse	1) Check sensing leads to AVR. 2) Carry out Separate Excitation Test Procedure.
Voltage unstable, either on no-load or with load	1) Check speed stability. 2) Check "STAB" setting. Refer to Load Testing section for procedure.
Low voltage On-load	1) Check speed. 2) If correct check "UFRO" setting.
Excessive voltage / speed Dip on load Switching	1) Check governor response. Refer to generating set manual. 2) Check "DIP" setting.
Sluggish recovery on load switching	Check governor response. Refer to generating set manual.

Separate Excitation Test Procedure

Important: The resistances quoted apply to a standard winding. For generators having windings or voltages other than those specified refer to factory for details. Ensure all disconnected leads are isolated and free from earth.

Important: Incorrect speed setting will give proportional error in voltage output.

Checking the Permanent Magnet Generator (PMG).

Start the set and run at rated speed.

Measure the voltages at the AVR terminals P2, P3 and P4. These should be balanced and within the following ranges: 50Hz generators - 170-180 volts. 60Hz generators - 200-216 volts.

Should the voltages be unbalanced stop the set, remove the PMG sheet metal cover from the non-drive end bracket and disconnect the multi-pin plug in the PMG output leads. Check leads P2, P3, and P4 for continuity. Check the PMG stator resistances between output leads. These should be balanced and within +/-10% of 2.6 ohms for the 4 pole generators and 5.6 ohms on 6 pole generators. If resistances are unbalanced and/or incorrect the PMG stator must be replaced. If the voltages are balanced but low and the PMG stator winding resistances are correct - the PMG rotor must be replaced.

Checking Generator Windings and Rotating Diodes

This procedure is carried out with leads F1 & F2 (X and XX) disconnected at the AVR or and using a 12 V d.c. supply connected to leads F1 & F2 (X and XX).

Start the set and run at rated speed.

Measure the voltages at the main output terminals U, V and W. If voltages are balanced and within +/-1% of the generator nominal voltage, go to section on 'Balanced Main Terminal Voltages'.

Check voltages at AVR terminals 6, 7 and 8. These should be balanced and between 170-250 volts. If voltages at main terminals are balanced but voltage at 6, 7 and 8 are unbalanced, check continuity of leads 6, 7 and 8. Where an isolating transformer is fitted (MX321 AVR) check transformer windings. If faulty the transformer unit must be replaced.

If voltages are unbalanced, refer to the section on 'Unbalanced Main Terminal Voltages'.

Balanced Main Terminal Voltages

If all voltages are balanced within 1% at the main terminals, it can be assumed that all exciter windings, main windings and main rotating diodes are in good order, and the fault is in the AVR. Refer the section for the 'AVR Function Test'.

If voltages are balanced but low, there is a fault in the main excitation windings or rotating diode assembly.

Check Rectifier Diodes

The diodes on the main rectifier assembly can be checked with a multimeter. The flexible leads connected to each diode should be disconnected at the terminal end, and the forward and reverse resistance checked. A healthy diode will indicate a very high resistance (infinity) in the reverse direction, and a low resistance in the forward direction. A faulty diode will give a full deflection reading in both directions with the test meter on the 10,000 ohms scale, or an infinity reading in both directions. On an electronic digital meter a healthy diode will give a low reading in one direction, and a high reading in the other.

Replacement of Faulty Diodes

The rectifier assembly is split into two plates, the positive and negative, and the main rotor is connected across these plates. Each plate carries 3 diodes, the negative plate carrying negative biased diodes and the positive plate carrying positive biased diodes. Care must be taken to ensure that the correct polarity diodes are fitted to each respective plate. When fitting the diodes to the plates they must be tight enough to ensure a good mechanical and electrical contact, but should not be over tightened. The recommended torque tightening is 4.06 - 4.74Nm (36-42 lb in).

Surge Suppressor

The surge suppressor is a metal-oxide varistor connected across the two rectifier plates to prevent high transient reverse voltages in the field winding from damaging the diodes. This device is not polarised and will show a virtually infinite reading in both directions with an ordinary resistance meter. If defective this will be visible by inspection, since it will normally fail to short circuit and show signs of disintegration. Replace if faulty.

Main Excitation Windings

If after establishing and correcting any fault on the rectifier assembly the output is still low when separately excited, then the main rotor, exciter stator and exciter rotor winding resistances should be checked (see Resistance Charts), as the fault must be in one of these windings. The exciter stator resistance is measured across leads F1 & F2 (X and XX). The exciter rotor is connected to six studs, which also carry the diode lead terminals. The main rotor winding is connected across the two rectifier plates. The respective leads must be disconnected before taking the readings. Resistance values should be within +/-10% of the values given in the tables at the back of this manual.

Unbalanced Main Terminal Voltages

If voltages are unbalanced, this indicates a fault on the main stator winding or main cables to the circuit breaker.

Note: Faults on the stator winding or cables may also cause noticeable load increase on the engine when excitation is applied.

Disconnect the main cables and separate the winding leads U1-U2, (U5-U6), V1-V2, (V5-V6), W1-W2, (W5-W6) to isolate each winding section.

Note: Leads suffixed 5 and 6 apply to 12 wire windings only.

Measure each section resistance - values should be balanced and within +/-10% of the value given at the back of this manual

Measure insulation resistance between each phase and each phase to earth.

Unbalanced or incorrect winding resistances and/or a low insulation resistance to earth indicates defective or contaminated windings. See Winding condition in the Service Section.

Cleaning the windings requires specialist equipment and is therefore beyond the scope of this manual.

Excitation Control Test

AVR Function Test

Remove exciter field leads X & XX (F1 & F2) from the AVR terminals X & XX (F1 & F2).

Connect a 60W 240V household lamp to AVR terminals X & XX (F1 & F2).
Set the AVR VOLTS control potentiometer fully clockwise.
Connect a 12V, 1.0A DC supply to the exciter field leads X & XX (F1 & F2) with X (F1) to the positive.
Start the generating set and run at rated speed.
Check that the generator output voltage is within +/- 10% of rated voltage.

Voltages at P2, P3, P4 terminals can be found in the data section of this manual
If the generator output voltage is correct but the voltage on 7-8 (or P2- P3) is low, check auxiliary leads and connections to main terminals.

The lamp connected across X & XX should glow for approximately 10 seconds and then turn off. Failure to turn off indicates faulty protection circuit and the AVR should be replaced. Turning the "VOLTS" control potentiometer fully anti-clockwise should turn off the lamp.

Should the lamp fail to light the AVR is faulty and should be replaced.

Important After this test turn VOLTS control potentiometer fully anti-clockwise.

To reset the voltage, start the generating set and run on no-load at nominal frequency. Slowly turn VOLTS control potentiometer clockwise until rated voltage is reached.

Accessories

The following accessories are available with the MX321 & MX341 AVR as fitted options. These control accessories may be fitted in the generator terminal box. If fitted at the time of supply, the wiring diagram(s) in the back of this book shows the connections. When the options are supplied separately, fitting instructions are provided with the accessory.

Paralleling Droop kit	Manual Voltage Regulator	Power Factor Control	Current Limiting
-----------------------	--------------------------	----------------------	------------------

Remote Voltage Adjustment.

A remote voltage adjustment trimmer (hand trimmer) can be fitted. If fitted it connects across AVR terminals 1 & 2. If a remote trimmer is not used, terminals 1 & 2 will be linked. When the remote trimmer is used the link across terminals 1 & 2 must be removed.

Parallel Operation

Understanding of the following notes on parallel operation is useful before attempting the fitting or setting of the droop kit accessory. (see synchronising notes)

When operating in parallel with other generators or the mains, it is essential that the incoming generator matches the condition of the busbar.

Voltage difference	+/- 0.5%
Frequency difference	0.1 Hz/sec
Phase angle	+/- 10°
C/B closing time	50 ms
The Phase sequence must match	

The settings for the synchronising equipment to achieve this must be within these parameters.

The voltage difference when paralleling with the grid/mains utility is +/- 3% .

Caution: Failure to meet these conditions before closing the interconnecting circuit breaker between two or more running generators will generate excessive mechanical and electrical stresses, resulting in serious damage to the generators and associated equipment.

A variety of techniques, varying from simple synchronising lamps to fully automatic synchronisers, can be used to ensure these conditions are met.

Once connected in parallel a minimum instrumentation level per generator of voltmeter, ammeter, wattmeter (measuring total power per generator), and frequency meter is required in order to adjust the engine and generator controls to share kW in relation to engine ratings and kVAr in relation to generator ratings.

Load Sharing

It is important to recognise that:

kW load is derived from the engine, the speed governor characteristics determine the kW sharing between sets. To set up the governor Read generating set manufacturer's instructions for setting controls

kVA load is derived from the generator, and the excitation control characteristics determine the kVA sharing.

Droop

Quadrature droop is the most commonly used method of kVAr sharing. The droop circuit creates a generator voltage characteristic that falls with decreasing power factor (increasing kVAr). This is achieved with an additional current transformer (C.T.) and a burden resistor on the AVR board. The C.T. provides a signal dependent on the current phase angle (i.e. the power factor). This and a percentage of the burden resistor voltage are summed into the AVR circuit. Increasing droop is obtained by turning the DROOP control potentiometer clockwise.

Generally 5% droop at full load current zero p.f. is sufficient to ensure kVAr sharing.

If the droop accessory C.T. has been supplied with the generator it will have been tested to ensure correct polarity and set to a nominal level of droop. The final level of droop will be set during generating set commissioning.

Although nominal droop setting may be factory set it is advisable to go through the setting procedure below.

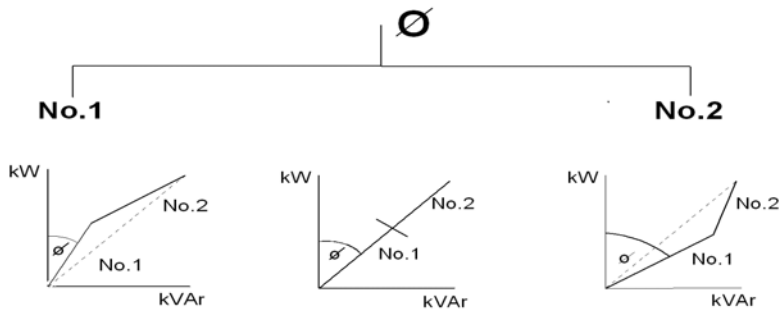

Although nominal droop setting may be factory set it is advisable to go through the setting procedure below.

Droop Setting Procedure

Depending upon available load the following settings should be used - all are based on rated current level.

0.8 p.f. load (at full load current) set droop to 3%

zero p.f. load (at full load current) set droop to 5%

Setting the droop with low power factor load is the most accurate.

Run each generator as a single unit at rated frequency or rated frequency + 4% depending upon type of governor and nominal voltage. Apply available load to rated current of the generator. Adjust 'DROOP' control potentiometer to give droop in line with above table. Clockwise rotation increases amount of droop. Refer the section for the appropriate AVR to establish the location of the droop potentiometer.

Note 1) Reverse polarity of the C.T. will raise the generator voltage with load. The polarities S1&S2 shown on the wiring diagrams are correct for clockwise rotation of the generator looking at the drive end. Reversed rotation requires S1&S2 to be reversed.

Note 2) the most important aspect is to set all generators equal. The precise level of droop is less critical.

Note 3) A generator operated as a single unit with a droop circuit set at rated load 0.8 power factor is unable to maintain the usual 0.5% regulation. A shorting switch can be connected across S1&S2 to restore regulation for single running.

Caution: LOSS OF FUEL to an engine can cause its generator to motor with consequent damage to the generator windings. Reverse power relays should be fitted to trip main circuit breaker.

Caution: LOSS OF EXCITATION to the generator can result in large current oscillations with consequent damage to generator windings. Excitation loss detection equipment should be fitted to trip main circuit breaker.

Manual Voltage Regulator (MVR)

This accessory is provided as an 'emergency' excitation system, in the event of an AVR failure.

Powered from a PMG output the unit is manually set, but automatically controls the excitation current, independent of generator voltage or frequency.
The unit is provided with 'MANUAL', 'OFF', 'AUTO' switching facility.

'MANUAL':

Position connects the exciter field to the MVR output. The generator output is then controlled by the operator adjusting the excitation current.

'OFF'

Disconnects the exciter field from both MVR and the normal AVR.

'AUTO'

Connects the exciter field to the normal AVR and the generator output is controlled at the pre-set voltage under AVR control.

Power Factor Controller (PFC3)

This accessory is primarily designed for those generator applications where operation in parallel with the mains supply is required.

Protection against loss of mains voltage or generator excitation is not included in the unit and the system designer must incorporate suitable protection.

The electronic control unit requires both droop and kVAr current transformers. When supplied with the generator, wiring diagrams inside the back cover of this manual show the connections and the additional instruction leaflet provided gives details of setting procedures for the Power Factor Controller.

The unit monitors the power factor of the generator current and adjusts excitation to maintain the power factor constant.

This mode can also be used to control the power factor of the mains if the point of current monitoring is moved to the mains cables. Refer to the factory for appropriate details.

It is also possible to operate the unit to control kVAr of the generator if required. Refer to the factory for appropriate details.

Service

Warning: Service and fault finding procedures present hazards which can result in severe personal injury or death. Only personnel qualified to perform electrical and mechanical service should carry out these procedures. Ensure engine-starting circuits are disabled before commencing service or maintenance procedures. Isolate any anti-condensation heater supply.

Winding Condition

Guidance of Typical Insulation Resistance [IR] Values

The following is offered as general information about IR values and is aimed at providing guidance about the typical IR values for generators from new, through to the point of refurbishment.

New Machines

The generator's Insulation Resistance, along with many other critical factors, will have been measured during the generator manufacturing process. The generator will have been transported with an appropriate packaging suitable for the method of delivery to the Generating Set assembler's works. The assembler is expected to store the generator in a suitable location, protected from adverse environmental (and other) conditions.

However, absolute assurance that the generator will arrive at the Genset production line with IR values still at the factory test levels of above 100 Megohm to be guaranteed.

At Generating Set Assembler's Works

The generator should have been transported and stored such that it will be delivered to the assembly area in a clean dry condition. If held in appropriate storage conditions the generator IR value should typically be 25 Megohm

If the unused/new generator's IR values fall below 5 Megohm then a drying out procedure should be implemented by one of the processes outlined below, before being despatched to the end customer's site. Some investigation should be undertaken into the storage conditions of the generator while on site.

Generators in Service

It is known that a generator will give reliable service with an IR value of just 1.0 Megohm. For a relatively new generator to be so low it must have been subjected to inappropriate operating or storage conditions. Any temporary reduction in IR values can be restored to expected values by following one of the drying out procedures.

Winding Condition Assessment

Caution: The AVR should be disconnected and the Resistance Temperature Detector (R.T.D.) leads grounded during this test.

Caution: The windings have been H.V. tested during manufacture and further H.V. testing may degrade the insulation with consequent reduction in operating life. Should it be necessary to demonstrate H.V. testing, for customer acceptance, the tests must be carried out at reduced voltage levels i.e.

Test Voltage= 0.8 (2 X Rated Voltage + 1000)

The condition of the windings can be assessed by measurement of insulation resistance [IR] between phase to phase, and phase to earth.

Measurement of winding insulation should be carried out: -

- As part of a periodic maintenance plan.
- After prolonged periods of shutdown.
- When low insulation is suspected, e.g. damp or wet windings.

Care should be taken when dealing with windings that are suspected of being excessively damp or dirty. The initial measurement of the [IR] Insulation Resistance should be established using a low voltage (500V) megger type instrument. If manually powered, the handle should initially be turned slowly so that the full test voltage will not be applied. If low values are suspected or immediately indicated the test should only continue for long enough to very quickly assess the situation.

Full megger tests (or any other form of high voltage test) should not be applied until the windings have been dried out, and if necessary cleaned.

Procedure for Insulation Testing

1. Disconnect all electronic components, AVR, electronic protection equipment etc. Ground the RTD's (Resistance Temperature Detection devices) if fitted.
2. Short out the diodes on the rotating diode assembly. Be aware of all components connected to the system under test that could cause false readings, or be damaged by the test voltage.
3. Carry out the insulation test in accordance with the 'operating instructions' for the test equipment.
4. The measured value of insulation resistance for all windings to earth and phase to phase should be compared with the guidance given above for the various 'life stages' of a generator. The minimum acceptable value is 1.0 Megohm on a 500V megger.

If low winding insulation is confirmed, one or more of the methods, given below, for drying the winding should be carried out.

Methods of Drying Out Generators

Cold Run

In the case of a generator in otherwise good condition that has not been run for some time, and has been standing in damp, humid conditions a simple procedure may suffice. It is possible that simply running the generator set unexcited – AVR terminals "K1" "K2" open circuit - for a period of say 10 minutes will sufficiently dry the surface of the windings and raise the IR to greater than 1.0 Megohm, and so allow the unit to be put into service.

Blown Air Drying

Remove the covers from all apertures to allow the escape of the water-laden air. During drying, air must be able to flow freely through the generator in order to carry off the moisture.

Direct hot air from two electrical fan heaters of around 1 – 3 kW into the generator air inlet apertures. Ensure the heat source is at least 300mm away from the windings to avoid over heating and damage to the insulation.

Apply the heat and plot the insulation value at half hourly intervals. The process is complete when the parameters covered in the section entitled, 'Typical Drying Out Curve', are met.

Remove the heaters, replace all covers and re-commission as appropriate.

If the set is not to be run immediately ensure that the anti-condensation heaters are energised, and retest prior to running.

Short Circuit Method

Warning: This process should only be performed by a competent engineer familiar with safe operating practices within and around generator sets of the type in question. Ensure the generator is safe to work on, initiate all mechanical and electrical safety procedures pertaining to the genset and the site.

Caution: The short circuit must not be applied with the AVR connected in circuit. Current in excess of the rated generator current will cause damage to the windings.

1. Bolt a short circuit of adequate current carrying capacity, across the main terminals of the generator. The shorting link should be capable of taking full load current.
2. Disconnect the cables from terminals "X" and "XX" of the AVR.
3. Connect a variable dc supply to the "X" (positive) and "XX" (negative) field cables. The dc supply must be able to provide a current up to 2.0 Amp at 0 - 24 Volts.
4. Position a suitable ac ammeter to measure the shorting link current.
5. Set the dc supply voltage to zero and start the generating set. Slowly increase the dc voltage to pass current through the exciter field winding. As the excitation current increases, so the stator current in the shorting link will increase. This stator output current level must be monitored, and not allowed to exceed 80% of the generator's rated output current.

6. After every 30 minutes of this exercise:
Stop the generator and switch off the separate excitation supply, measure and record the stator winding IR values, and plot the results. The resulting graph should be compared with the classic shaped graph. This drying out procedure is complete when the parameters covered in the section entitled 'Typical Drying Out Curve' are met.
7. Once the Insulation Resistance is raised to an acceptable level - minimum value 1.0 Megohm the dc supply may be removed and the exciter field leads "X" and "XX" re-connected to their terminals on the AVR.
8. Rebuild the genset, replace all covers and re-commission as appropriate.
9. If the set is not to be run immediately ensure that the anti-condensation heaters are energised, and retest the generator prior to running.

Typical Drying Out Curve

Whichever method is used to dry out the generator the resistance should be measured every half-hour and a curve plotted as shown

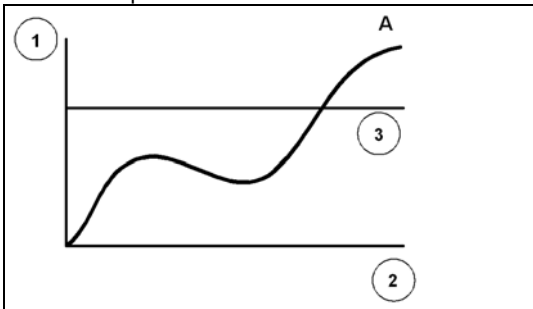

- 1) Y axis = Resistance
- 2) X axis = Time
- 3) One Megohm limit

The illustration shows a typical curve for a machine that has absorbed a considerable amount of moisture. The curve indicates a temporary increase in resistance, a fall and then a gradual rise to a steady state. Point 'A', the steady state, must be greater than 1.0 Megohm (If the windings are only slightly damp the dotted portion of the curve may not appear). For general guidance, expect that the typical time to reach point 'A' will be around 3 hours.

Drying should be continued after point "A" has been reached for at least one hour.

It should be noted that as winding temperature increases, values of insulation resistance may significantly reduce. Therefore, the reference values for insulation resistance can only be established with windings at a temperature of approximately 20°C.

If the IR value remains below 1.0 Megohm, even after the above drying methods have been carried out correctly, then a Polarisation Index test [PI] should be carried out.

If the minimum value of 1.0 Megohm for all components cannot be achieved, rewinding or refurbishment of the generator will be necessary.

Caution: The generator must not be put into service until the minimum values are achieved.

After drying out, the insulation resistances should be rechecked to verify the minimum resistances quoted above are achieved. On re-testing it is recommended that the main stator insulation resistance is checked as follows:

Separate the neutral leads

Ground V and W phase and megger U phase to ground

Ground U and W phase and megger V phase to ground

Ground U and V phase and megger W phase to ground

Caution: The generator must not be run if the minimum insulation value of 1.0 Megohm is not obtained.

Air Filters

Air filters for the removal of airborne particulate matter (dust) are offered as an addition to the standard build option. The filter elements do not remove and must not be allowed to get wet.

The frequency of filter maintenance will depend upon the severity of the site conditions. Regular inspection of the elements will be required to establish when cleaning is necessary.

Caution: Do not charge filters with oil.

Warning: Removal of filter elements enables access to LIVE parts. Only remove elements with the generator out of service.

Air Filter Cleaning Procedure

1. Remove the filter elements from the filter frames, taking care not to damage them.
2. Invert the filters dirty side down and agitate to remove particles of dirt.
To remove stubborn particles low-pressure air can be used, in the reverse direction of flow, to force out stubborn particles.
If necessary use a soft brush to gently brush off any remaining dirt particles.
3. Clean the sealing gaskets and surrounding area.
4. Visually check the condition of the filter elements and sealing gaskets, replace as necessary.
5. Ensure that the filter elements are dry before putting them back into service.
6. Carefully replace the filter elements

Maintenance

Warning: Before disassembling or assembling procedures are carried out ensure that the generating set is inhibited mechanically and isolated electrically.

Anti-Condensation Heaters

Warning: The electrical supply to the heaters must be isolated before attempting any work adjacent to the heater.

If anti condensations heaters are defect repair by replacement. Access is available via the air inlets at the non-drive end.

Removal of Permanent Magnet Generator (PMG)

1. Remove access cover if fitted (4).
2. Disconnect the multi-pin electrical connector
3. Remove the bolts retaining the stator .
4. Tap the stator (2) out of its spigot and remove.
5. Note: As the highly magnetic rotor will attract the stator core, care must be taken to avoid a contact which may damage the winding.
6. Remove the exciter rotor securing bolt (5) and stow safely. Firmly pull the complete rotor assembly (3) from its location.

Note: Keep the rotor clean and avoid contact with metal dust or particles.

Note: The rotor assembly must not be dismantled.

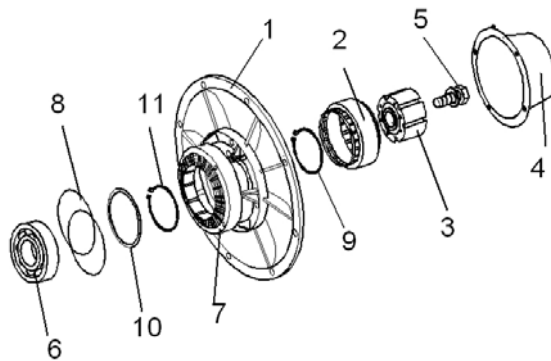

Re-assembly

- Re-assembly is a reversal of the above procedure.
- Ensure rotor magnet assembly is free of metal pieces or particles.
- Care is needed to avoid winding damage when re-assembling the stator pack, due to strong magnetic attraction.

Removal of Bearings

Caution: When lifting single bearing generators, care is needed to ensure the generator frame is kept in the horizontal plane. The rotor is free to move in the frame and can slide out if not correctly lifted. Incorrect lifting can cause serious injury to personnel.

Caution: Always position the main rotor so that a full pole face of the main rotor core is at the bottom.

Note: Removal of the bearings may be effected either after the rotor assembly has been removed or more simply by removal of endbracket(s).

Note: Be sure to note the location of all components during removal to assist during the assembly process

Removal of the non drive end Bearing.

Note: This procedure assumes that there is sufficient space to carry out the work, if not it will be necessary to remove the generator from the generating set.

1. Remove the PMG
2. Disassemble remove the bearing grease pipes.
3. Remove 4 bolts from the bearing cap (2). Discard the wave-washer (11).
4. Remove the bearing cap and remove 4 bolts from the end bracket, holding the bearing cartridge (13).
5. Remove 8 bolts from the endbracket (1).

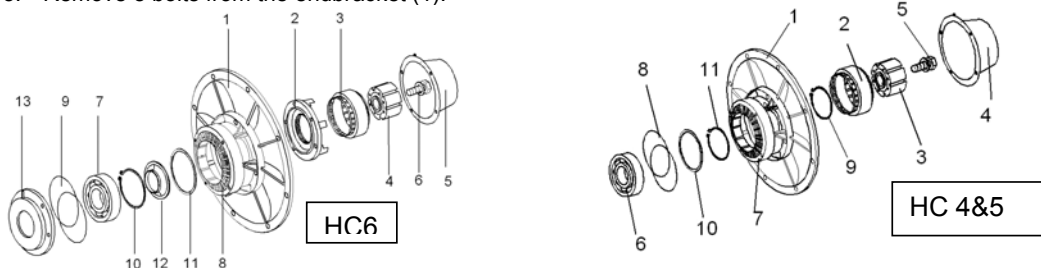

6. Support the endbracket with a hoist, insert two M10 jacking bolts (on the end bracket horizontal centre line) to drive the endbracket from the spigot. Screw in the bolts until the end bracket spigot is clear of the locating recess, lower the whole assembly until the main rotor is resting in the stator bore. Still supporting the non drive end bracket, tap the bracket off the non drive end bearing cartridge (taking care that the exciter stator does not foul exciter rotor windings) and remove.
7. Lift the endbracket (1) and place aside.
8. Use bearing pullers to remove and discard the flinger (12)
9. Use circlip pliers to remove and discard the circlip (10).
10. Use bearing pullers to remove the bearing (7) by pulling on the bearing cartridge (13).

Drive End Bearing Removal

Note: To access the drive end bearing it is necessary to remove the generator from the generating set and remove the coupling arrangements.

Carry out the same procedure as used for the single bearing arrangement.

Removal of the Main Rotor

This procedure is similar for both single and two bearing arrangements and assumes that the generator has been removed from the generating set.

Note: Position the rotor so that a full pole face is at bottom dead centre.

1. Remove the PMG (if fitted)
2. Remove the bearing and discard. Never refit the rotor with the old bearings.
3. Remove all access covers and terminal box lid.
4. Locate the exciter field leads X & XX and disconnect them.
5. To withdraw the rotor from the stator the rotor must be supported by a rope at the drive end and eased out of the stator core until half the main rotor is protruding out of the stator. At this point it is safe to release the weight from the rope sling.
6. Tightly bind a rope sling around the rotor core, and supporting the non-drive end of the rotor, guide it clear of the stator.

Caution: The rope sling may not be at the centre of gravity of the rotor and guidance at the ends of the rotor is essential. The full weight of the rotor given in the table below must be supported by the crane and sling. If the rotor core is allowed to drop more than a few millimetres at this point, it will make contact with the stator windings and may damage them.

Re-assembly is a reversal of the above procedure.

Note: Before assembly of a single bearing rotor into stator housing check that the drive discs are not damaged or cracked or showing any other signs of fatigue. Also check that holes in the discs for drive fixing screws are not elongated.

- Damaged components must be replaced.
- Refer to torque setting at the back of this book when refitting the drive discs.
- Refer to engine manual for torque setting of disc to flywheel bolts.

Refitting Bearings

Caution: Every effort must be made to establish a clean area around the generator when removing and replacing bearings. Contamination is a major cause of bearing failures.

Equipment

- Suitable cleaning solvent
- Thin protective gloves
- Lint free cleaning cloth
- Induction heater.

Preparation

Caution: Ensure that the bearing contact surfaces show no sign of wear or corrosion prior to fitting the bearing.

Caution: Never refit used bearings, grease flingers, wave washer or 'O' rings.

Caution: Only the outer race should be used to transmit load during assembly (NEVER use the inner race).

1. The bearing cap(s) and cartridge(s) must be thoroughly flushed out with clean solvent and checked for wear or damage, before re-assembly. Damaged components should be replaced before refitting the bearing.
2. Note: Gloves must be worn at all times when handling the bearings, grease and solvent.
3. Wipe clean the assembly surface, using cleaning solvent on lint free cloth.
4. Wipe clean: Bearing Cartridge, Wave Washer, Bearing Cap, grease flinger, all re-lubrication pipes and fittings (internal and external). Visually inspect all components after cleaning, for contamination.
5. Place all components on the clean assembly surface.
6. Caution: Do not use an air line to blow off excess fluid.
7. Thoroughly clean the external surface of the grease gun nozzle using lint free cloth.

Bearing preparation

8. Remove the bearing from its packaging.
9. Wipe off the preservative oil from the surface of the inner and outer rings - using lint free cloth only.
10. Place the bearing on the clean assembly surface, with the bearing designation marking facing down.
11. Apply half the specified bearing grease fill quantity to the upper face of the bearing (opposite side to the bearing designation markings).
12. Thumb the applied grease into the bearing, ensuring good penetration into the raceways/balls (use clean protective gloves).

Bearing Cartridge

Note: grease quantities can be found in the back of this book

13. Apply the specified cartridge grease fill quantity to the back face of the bearing housing.
14. Apply a small amount of grease to the grooved sealing surface in the cartridge.
15. Apply anti-fretting lubricant (MP14002 - Klüber Altemp Q NB 50) to the bearing housing circumference. Apply paste in a thin coherent layer by use of a lint free cloth (DO NOT rub in) (use clean protective gloves).
16. Non-drive end - fit new 'O' Rings into the 'O' Ring grooves in the bearing housing circumference.

Assemble Bearing into Cartridge

17. Heat the bearing cartridge to 25° C above ambient with an induction heater (Do not exceed 100°C).
18. With greased face of the bearing facing the cartridge bore, fit the bearing into the bearing housing.

Ensure the bearing outer race contacts the location shoulder.

Assemble Bearing onto Shaft

19. Heat the Bearing and Cartridge assembly to 80°C above ambient with an induction heater (use induction heater, no other heat source is suitable)
20. Slide the Bearing and Cartridge assembly over the shaft, pushing it firmly against the bearing seating shoulder.
21. Rotate the assembly (including inner race) 45° in either direction, to provide correct alignment. The bearing must be held firmly in place until it is cool enough to positively self locate.

Note: Ensure cartridge is at ambient temp. before assembling bracket.

Bearing Cap & Flinger

22. Apply the specified cap grease fill quantity to the inside face of the cap.
23. Fill the grease exhaust slot with grease.
24. Apply a small amount of grease to the grooved sealing surface in the cap.
25. Fit circlip. (single bearing only).
26. Heat flinger to 120°C and place on shaft up to the bearing inner race. Hold firmly until positively located.
27. Place wave washer in cap, fit cap to bearing cartridge.

Re-lubrication pipe

28. Fill pipe and grease nipple with grease.
29. Fit pipe work to machine.

Returning To Service

After rectification of any faults found, remove all test connections and reconnect all control system leads.

30. Refit all terminal box covers/access covers and reconnect heater supply.
31. Carry out pre-running checks
32. Restart the set and adjust VOLTS control potentiometer on AVR by slowly turning clockwise until rated voltage is obtained.

Warning: Failure to refit all guards, access covers and terminal box covers can result in injury or death.

Bearing Maintenance

Re-lubrication

Ensure that the grease, grease gun, grease gun nozzle and re-lubrication nipple are free from abrasive materials and other contaminants.

If the generator is running, apply the specified quantity of grease via the grease nipple (see table below). Keep the generator running for at least 10 minutes after applying the grease.

If the generator is not running, apply the grease as above then start the generator and run for at least 10 minutes to allow excess grease to exhaust from the bearing assembly.

Exhaust grease can build up inside of the PMG cover. At the first opportunity, when the generator is stopped, remove the PMG cover and clean out any build up of exhaust grease.

Warning: Do not remove the PMG cover with the generator r

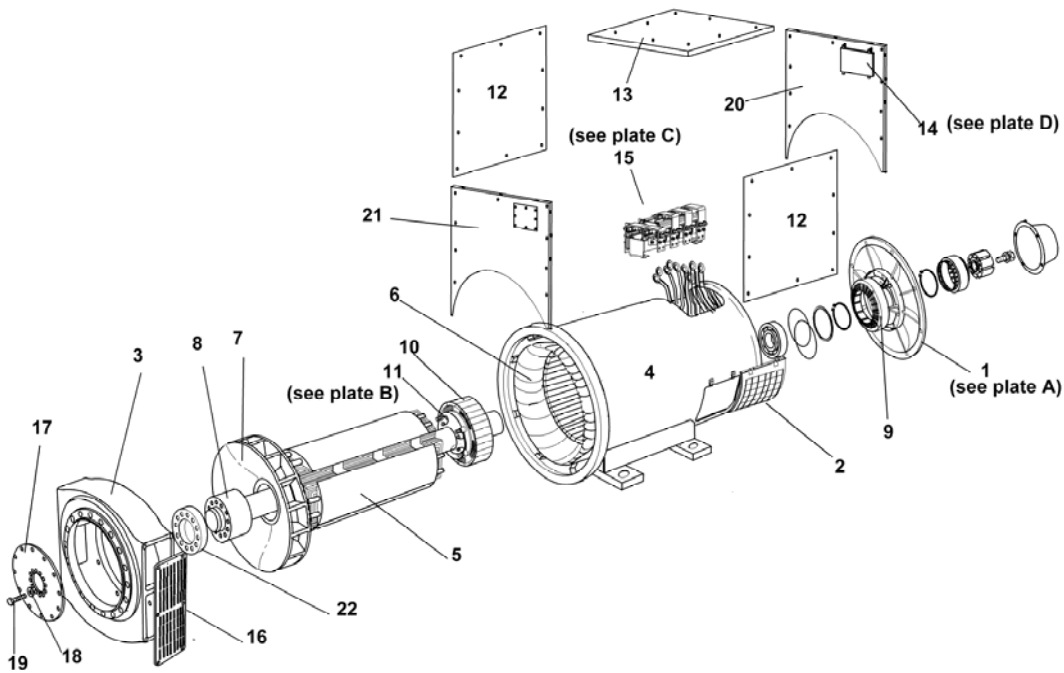

ITEM No.	DESCRIPTION
	HC4 & HC5 single bearing
1	N. D. E. Bracket (Non Drive End)
2	N. D. E. Cover
3	D. E. Adaptor SAE-0 (Drive End)
4	Main Frame Only (Non Service Part)C,D,E
4	Main Frame Only (Non Service Part)F
5	Wound Main Stator Assembly(No sensors)
6	Wound Rotor Assembly Complete
7	Fan
8	SHAFT (Non Service Part)
9	Wound Exciter Stator 65mm
10	Wound Exciter Rotor 65mm
11	Rotating Rectifier Assembly
12	Terminal Box Side Panel
13	Terminal Box Lid
14	A. V. R. MX341-2
15	Main Terminal Arrangement
16	Drive End Screen
17	Coupling Disc SAE 18
18	Coupling Disc Washer
19	Coupling Bolt M20 x 60 Long
20	Terminal Box Endpanel N.D.E.

21	Terminal Box Endpanel D.E.
22	Coupling Spacer
23	Foot Hole Reducing Bush

ITEM DESCRIPTION
HC 4&5

- 1 N.D.E. Bracket
- 2 Perm Magnet Stator Assy
- 3 Perm Magnet Rotor Assy
- 4 Perm Magnet Endcover
- 5 P M Rotor Fixing Bolt
- 6 Bearing
- 7 Exciter Stator
- 8 Bearing O Ring
- 9 Circlip
- 10 Waved washer
- 11 Circlip

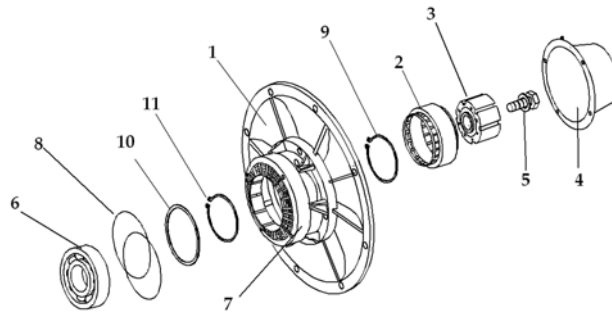

(Items 2 to 5 supplied as Permanent Magnet Kit)
(Items 6, 8, & 10 supplied as Replacement Bearing Kit)

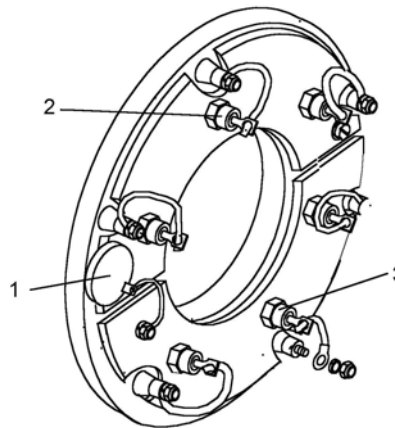

ITEM DESCRIPTION
HC 4&5

- 1 Varistor Assembly
- 2 Diode Forward (1 SET of 3)
- 3 Diode Reverse (1 SET of 3)

(Items 1 to 3 supplied as Rectifier Service Kit)

Parts Identification HC6

Single Bearing Generator

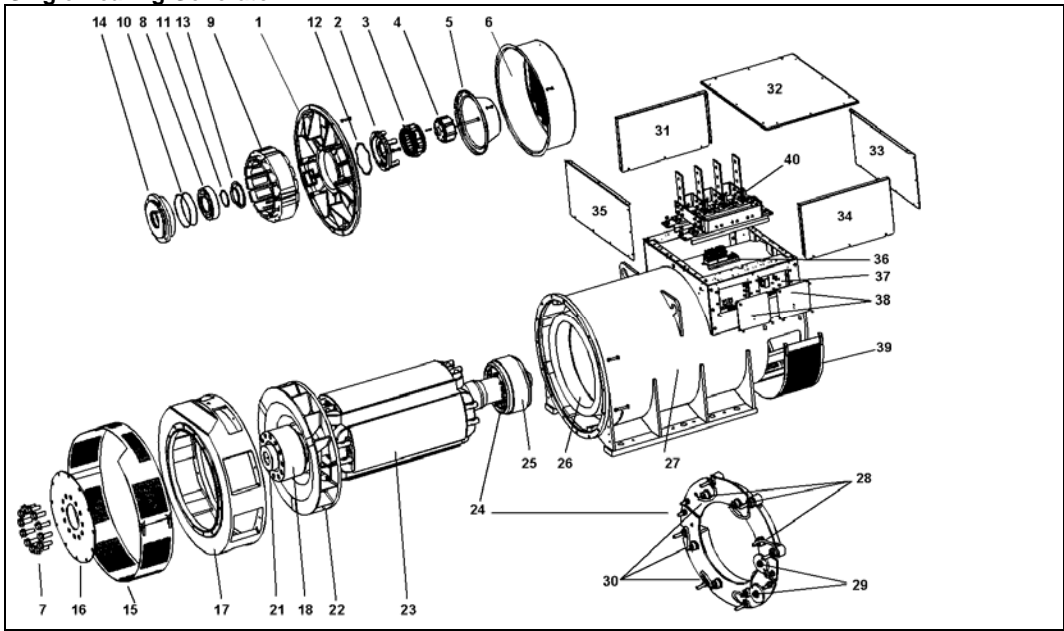

Item No.	Replacement parts	Item No.	Replacement parts	Not supplied as individual parts
1	NDE Bracket	23	Rotor	Includes:
2	NDE bearing cap (HC6)	2		Bearing cap
3	PMG stator	8		Bearing kit
4	PMG rotor	14		Bearing cartridge
5	PMG Cover	18		Shaft hub
6	Rear air inlet cover (if fitted)	21		Shaft
7	Bolts for discs	22		Fan
9	Main Exciter Stator	24		Rectifier assembly
14	NDE brg cartridge (HC6)	25		Exciter rotor
15	NDE cover	27	Main Frame	Includes:
16	Coupling Disc	26		Wound Stator
17	DE Adapter	24	Rotating rectifier	Kit contains
31	Terminal box side panel	28		3 forward diodes
32	Terminal box lid	29		2 varistors
33	Terminal box endpanel	30		3 reverse diodes
34	Terminal box side panel	Kit	NDE bearing	Kit contains:
35	Terminal box endpanel DE	8		Bearing
36	Isolating transformer	10		2 X bearing 'O' rings
37	AVR & fixing arrangement	11		Circlip
38	AVR access covers	12		Waved washer
39	NDE cover	13		Grease Flinger
40	Main terminals			

Two Bearing Generator.

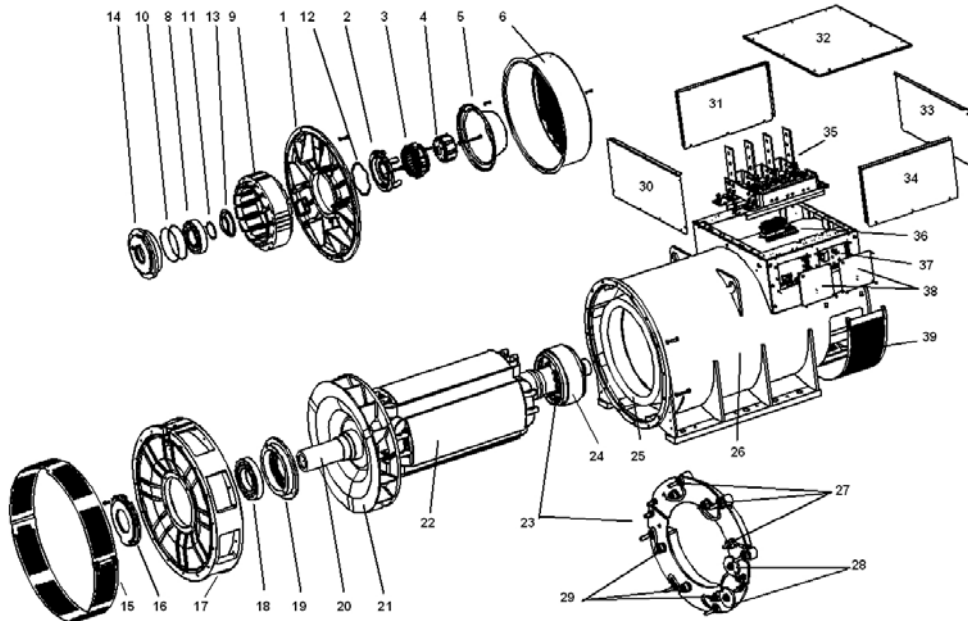

Item No.	Replacement parts	Item No.	Replacement parts	Not supplied as individual parts
1	NDE Bracket	22	Rotor	Includes:
2	NDE bearing cap	16 & 2		Bearing cap DE & NDE
3	PMG stator	18 & 8		Bearing kit DE & NDE
4	PMG rotor	14 &		Bearing cartridge DE &
5	PMG Cover	20		Shaft
6	Rear air inlet cover (if	21		Fan
9	Main Exciter Stator	30		Rectifier assembly
14	NDE bearing cartridge	24		Exciter rotor
15	NDE cover	26	Main Frame	Includes:
16	Coupling Disc	25		Wound Stator
17	DE Adapter	23	Rotating rectifier	Kit contains:
30	Terminal box endpanel	27		3 forward diodes
31	Terminal box side panel	28		2 varistors
32	Terminal box lid	29		3 reverse diodes
33	Terminal box endpanel	8	NDE bearing	Kit contains:
34	Terminal box side panel	10		Bearing
35	Main terminals			2 X bearing 'O' rings
36	Isolating transformer	12		Waved washer
37	AVR & fixing	13		Grease Flinger
38	AVR access covers	18	DE bearing	Kit contains:
39	NDE cover			Bearing
				2 X bearing 'O' rings
				Grease Flinger

Spares and After Sales Service

Recommended Spares

We recommend the use of genuine service parts supplied from one of our service outlets; these are supplied conveniently packaged for easy identification. Genuine parts may be recognised by the STAMFORD logo.

The recommend spares for Service and Maintenance can be found in the Data section of this manual. In critical applications a set of these service spares should be held with the generator.

When ordering parts the machine serial number or machine identity number and type should be quoted, together with the part description. The machine serial number can be found on the 'generator's name plate'.

If the nameplate is missing look for additional markings; each generator has its unique serial number stamped in to the upper section of the drive-end frame end-ring. In addition each generator is supplied with two adhesive rectangular labels fixed inside the terminal box; each carries the generator's unique identity number. One label has been fixed to the inside of the terminal box sheet metal-work, and the second label fixed to the main frame of the generator.

Orders and enquiries for parts should be addressed to:

Parts Department,
Barnack Road,
Stamford,
Lincolnshire
PE9 2NB
England.

UK Telephone: +44 (0) 1780 484000
UK Fax: +44 (0) 1780 766074

After Sales Service

Service Engineers are available to give technical support and advice as well as carry out maintenance and repair through Stamford and our subsidiary companies. An on-site service and repair facility is also available at our Stamford Works.

UK Telephone: +44 (0) 1780 484732
UK Fax: +44 (0) 1780 484104

Kluber Asonic GHY72 Grease

All bearing trials and calculated life expectancy are based on the use of Kluber Asonic GHY 72. We recommend the use of this Ester Oil/Polyurea grease or an alternative grease with the same specification. The grease specification is available by request.

Kluber has a world-wide distribution network, contact the manufacturers for your nearest stockist.

Alternatively supplies can be purchased from STAMFORD parts in handy packages at advantageous rates. We also offer a suitable grease dispenser

Technical Data

Air Flow requirements - 4 pole & 6 pole(intake/outlet)

Formatted: Heading 3 Char Char Char

frequency	50 Hz		60 Hz		(intake – outlet)	
	speed	1500 rpm	1000rpm	1800 rpm	1200rpm	Pressure Drop
HC4		0.8 m ³ /sec	-	0.99m ³ /sec	-	6mm water
		1700cfm	-	2100cfm	-	(0.25")
HC5		1.04m ³ /sec	-	1.31m ³ /sec	-	6mm water
		2202cfm	-	2708cfm	-	(0.25")
HCK5		1.23m ³ /sec	-	1.59m ³ /sec	-	6mm water
		2615cfm	-	3366cfm	-	(0.25")
HC6		1.62m ³ /sec		1.96m ³ /sec		6mm water
		3420cfm		4156cfm		(0.25")

The air intake/outlet must be suitable for the air flow given in the table with additional pressure drops less than or equal to those shown:

Winding Resistances

4 POLE	Main Rotor	Exciter Stator	Exciter Rotor	PM Stator
4C	0.91	18	0.136	2.6
4D	1.04	18	0.136	2.6
4E	1.17	18	0.136	2.6
4F	1.35	18	0.136	2.6
5C	1.55	17	0.184	2.6
5D	1.77	17	0.184	2.6
5E	1.96	17	0.184	2.6
5F	2.16	17	0.184	5.6
6G	1.75	17	0.158	5.6
6H	1.88	17	0.158	5.6
6J	2.09	17	0.158	
6K	2.36	17	0.158	
6 POLE				
6G	1.12	17	0.2	
6H	1.33	17	0.2	
6J	1.5	17	0.2	
6K	1.75	17	0.2	

PMG stator resistance measured between P2, P3, P4 should be within +/-10%

Main Stator Winding Resistances

4 POLE	Wdg 311	Wdg 312	Wdg. 07	Wdg. 17	Wdg. 28
4C	0.0056	N/A	N/A	0.0115	Wdg. 26
4D	0.006	N/A	N/A	0.01	
4E	0.0045	N/A	N/A	0.0075	
4F	0.0037	N/A	N/A	0.0055	
5C	0.0032	N/A	N/A	0.0053	
5D	0.0024	N/A	N/A	0.004	
5E	0.0022	N/A	N/A	0.0034	
5F	0.0019	N/A	N/A	0.0025	
6G	0.0017	0.0034	0.0055	N/A	
6H	0.0013	0.0025	0.0036	N/A	
6J	0.0011	0.0022	0.003	N/A	
6K	0.0085	0.0017	0.0026	N/A	
6 POLE					
6G	0.0045	0.009	0.015	N/A	
6H	0.0032	0.0063	0.01	N/A	
6J	N/A	0.0049	0.007	N/A	
6K	0.002	0.0039	0.006	N/A	

Coupling disc Torque setting

Frame	No. Of Discs	Single Disc Thickness	Total Thickness	Tightening Torque
4	4	1.2	48	48 kgm
				479 Nm
5	4	1.2	4.8	48 kgm
				479 Nm
6	6	1.2	7.2	84 kgm
				822 Nm

Bending Moments

For the purposes of establishing the genset design the bending moment at the engine flywheel housing to generator adaptor interface should not exceed 275 kgm. (2000ft.lbs.) on frame 6, 140kgm. (1000ft.lbs.) on frame 4&5

Customer output cables

Clean plated surfaces with a degreasing agent, then lightly abrade them to remove any tarnish. Don't score the surface. The output cables should be connected to the terminals using grade 8.8 steel bolts and associated anti-vibration hardware. The table is for your guidance.

Frame	Hole Size	Bolt Size	Torque Nm
	17	16	90

Generator internal connections.

The torque settings for all connections within the generator, links, CTs, accessories, cables, etc., are 45Nm.

Re-lubrication Details for Regreasable Bearings				
Frame	Bearing Position	Grease Quantity		Lubrication Period
		cm ³	Grams	
5	Non-Drive End	33	29	4000 - 4500 Hrs
5	Drive End	46	41	4000 - 4500 Hrs
6	Non-Drive End	60	53	4000 - 4500 Hrs
6	Drive End	75	66	4000 - 4500 Hrs

Initial fill for Regreasable Bearings							
Frame	Bearing Position	bearing		cartridge		cap	
		cm ³	gms	cm ³	gms	cm ³	gms
5	Non-Drive End	65	58	33	29	33	29
5	Drive End	92	82	46	41	46	41
6	Non-Drive End	121	111	63	56	63	56
6	Drive End	156	139	78	69	78	69

Generator Weight

Kgms	Main Stator		Main Rotor		Complete generator	
	1B	2B	1B	2B	1B	2B
No Bearings						
4 pole						
4			473			
5			685			
6			1093			
6 pole						
4			1050			
5			1592			
6			1790			

Recommended Service Parts

Diode Set	RSK6001 (3 forward & 3 reverse diodes with Surge Suppressors)
MX321 AVR	
MX341 AVR	

Kluber Grease	45-0281
---------------	---------

STAMFORD part numbers for bearings.				
Bearing type	Bearing position	HC 4	HC 5	HC 6
Regreasable bearings	Drive end	N/A	Optional 051-01067	Optional 051-01064
	Non drive end	N/A	Optional 051-01068	Optional 051-01065
Sealed for life with cartridge	Drive end	Standard 051-01070	Standard 051-01071	Standard 051-01069
	Non drive end	N/A	N/A	Optional 051-01070
Sealed for life without cartridge	Drive end	N/A	N/A	N/A
	Non drive end	Optional 051-01072	Optional 051-01072	N/A

A.C. GENERATOR WARRANTY**Warranty Period**

In respect of a.c. generators the Warranty Period is eighteen months from the date when the goods have been notified as ready for despatch or twelve months from the date of first commissioning (whichever is the shorter period).

Defects, After Delivery

We will make good by repair, or at our option, by replacement, any fault that under proper use appears in the goods within the warranty period. Provided, on examination by us, the defect is solely due to defective material or workmanship. The defective part is to be promptly returned, carriage paid, to us at the factory, our Subsidiary or, if appropriate to the Dealer who supplied the goods. All identification marks and numbers must be intact to aid identification.

Any part repaired or replaced, under warranty, will be returned to the customer free of charge (via sea freight if outside the UK).

We shall not be liable for any expenses that may be incurred in removing or replacing any part sent to us for inspection or in fitting any replacement part supplied by us.

We shall be under no liability for defects in any goods which have not been properly installed in accordance with our recommended installation practices as detailed in the 'Installation, Service and Maintenance Manual' and Installation Guidelines.

We shall be under no liability for defects on products that have been improperly used or stored or which have been repaired, adjusted or altered by any person except our authorised agents or ourselves.

We shall not be liable for any second-hand goods, proprietary articles or goods not of our own manufacture although supplied by us, such articles and goods are being covered by the warranty (if any) given by the manufacturers.

All claims must contain full particulars of the alleged defect, the description of the goods, the Serial Number, the date of purchase, and the name and address of the Vendor (as shown on the manufacturer's identification plate). For Spare Parts, claims must contain the order reference under which the goods were supplied.

Our judgement, in all cases of claims, shall be final and conclusive and the claimant shall accept our decision on all questions as to defects and the exchange of a part or parts.

Our liability shall be fully discharged by either repair or replacement as above, and in any event shall not exceed the current list price of the defective goods.

Our liability under this clause shall be in lieu of any warranty or condition implied by law as to the quality or fitness for any particular purpose of the goods, and save as expressly provided in this clause we shall not be under any liability, whether in contract, tort or otherwise, in respect of defects in goods delivered or for any injury, damages or loss resulting from such defects or from any work undone in connection therewith.

Extensions to the warranty period

Extensions to the warranty period can be purchased, subject to additional terms and conditions pertaining to the specific application. Apply to the Stamford parts Department.

MACHINE SERIAL NUMBER.....

End of Life Disposal

Companies, specialising in reclaiming material from scrap products can reclaim most of the iron, steel and copper from the generator.

Recyclable material

Mechanically separate the base materials, iron, copper and steel, removing paint, polyester resin, and insulation tape and/or plastics residues from all components. Dispose of this 'waste material'

The iron, steel and copper can now be recycled.

Items requiring specialist treatment.

Remove electrical cable, electronic accessories and plastic materials from the generator. These components need special treatment to remove the waste from the reclaimable material.

Forward the reclaimed materials for recycling.

Waste material

Dispose of waste material from both of the above processes via a specialist disposal company.

STAMFORD WORLDWIDE

AUSTRALIA Tel: +61 2 9680 2299
Fax: +61 2 9680 1545

NORWAY Tel: +47 22 97 44 44
Fax: +47 22 97 44 45

CHINA Tel.: +86 51 0521 6212
Fax: +86 51 0521 7673

MEXICO Tel: +52 48 26 84 00
Fax: +52 48 26 84 05

GERMANY Tel: (49) (0) 61 03 50 39 0
Fax: (49) 61 03 50 39 40

SINGAPORE Tel: +65 6794 3730
Fax: +65 6898 9065

INDIA Tel: +91 20 402 5329-30
Fax: +91 20 402 5331

SPAIN Tel: +34 91 498 2000
Fax : +34 91 498 2004

ITALY Tel: +39 02 380 00714
Fax: +39 02 380 03664

U.S.A. Tel: +1 763 528 7301
Fax: +1 763 57485082

JAPAN Tel: +81 426 77 2881
Fax +81 426 77 2884

STAMFORD®

BARNACK ROAD, STAMFORD
LINCOLNSHIRE, PE9 2NB ENGLAND
Tel: +44 (0) 1780 484 000

Fax: +44 (0) 1780 484 100

'STAMFORD' is a registered trademark