

For Reference Purpose Only

SS460 AUTOMATIC AVR

SPECIFICATION, INSTALLATION AND ADJUSTMENTS



GENERAL DESCRIPTION

The SS460 is a half-wave phase-controlled thyristor type Automatic Voltage Regulator (AVR) and forms part of the excitation system for a brushless generator.

In addition to regulating the generator voltage, the AVR circuitry includes underspeed and sensing loss protection to ensure safe, reliable control of the generator. Excitation power is derived directly from the generator terminals.

Positive voltage build up from residual levels is ensured by the use of efficient semiconductors in the power circuitry of the AVR.

The AVR is linked with the main stator windings and the exciter field windings to provide closed loop control of the output voltage with load regulation of +/- 1.5%.

In addition to being powered from the main stator, the AVR also derives a sample voltage from the output windings for voltage control purposes. In response to this sample voltage, the AVR controls the power fed to the exciter field, and hence the main field, to maintain the machine output voltage within the specified limits, compensating for load, speed, temperature and power factor of the generator.

A frequency measuring circuit continually monitors the generator output and provides output underspeed protection of the excitation system, by reducing the output voltage proportionally with speed below a presettable threshold. A manual adjustment is provided for factory setting of the under frequency roll off point, (UFRO). This can easily be changed to 50 or 60 Hz in the field by push-on wire link selection.

Provision is made for the connection of a remote voltage trimmer, allowing the user fine control of the generator's output.

TECHNICAL SPECIFICATION

INPUT

Voltage	85-125 V ac	Jumper Selectable
	170-250 V ac	
Frequency	50-60 Hz nominal	
Phase	1	

OUTPUT

Voltage	max 90 V dc at 207 V ac input
Current	Continuous 4 A dc Transient 6 A for 10 seconds
Field Resistance	15 W minimum

REGULATION (See Note 1) +/- 1.5%

THERMAL DRIFT

(after 10 min)
1% for 40°C change in AVR ambient

TYPICAL SYSTEM RESPONSE

Field current to 90%	80ms
Machine Volts to 97%	300ms

EXTERNAL VOLTAGE ADJUSTMENT

+/- 5% with 1 K W trimmer

UNDER FREQUENCY PROTECTION

Set Point (See Note 2)	95% Hz
Slope	170% down to 30 Hz

UNIT POWER DISSIPATION

10 watts maximum

BUILD UP VOLTAGE

3.5 V ac @ AVR terminals

ENVIRONMENTAL

Vibration	20-100 Hz	50mm/sec
	100 Hz-2 kHz	3.3g
Relative Humidity	0-60°C	95%
Operating Temperature		-40°C to + 70°C
Storage Temperature		-55°C + 80°C

NOTES

1. With 4% engine governing.
2. Factory set, semi-sealed, jumper selectable.

DESIGN DETAILS

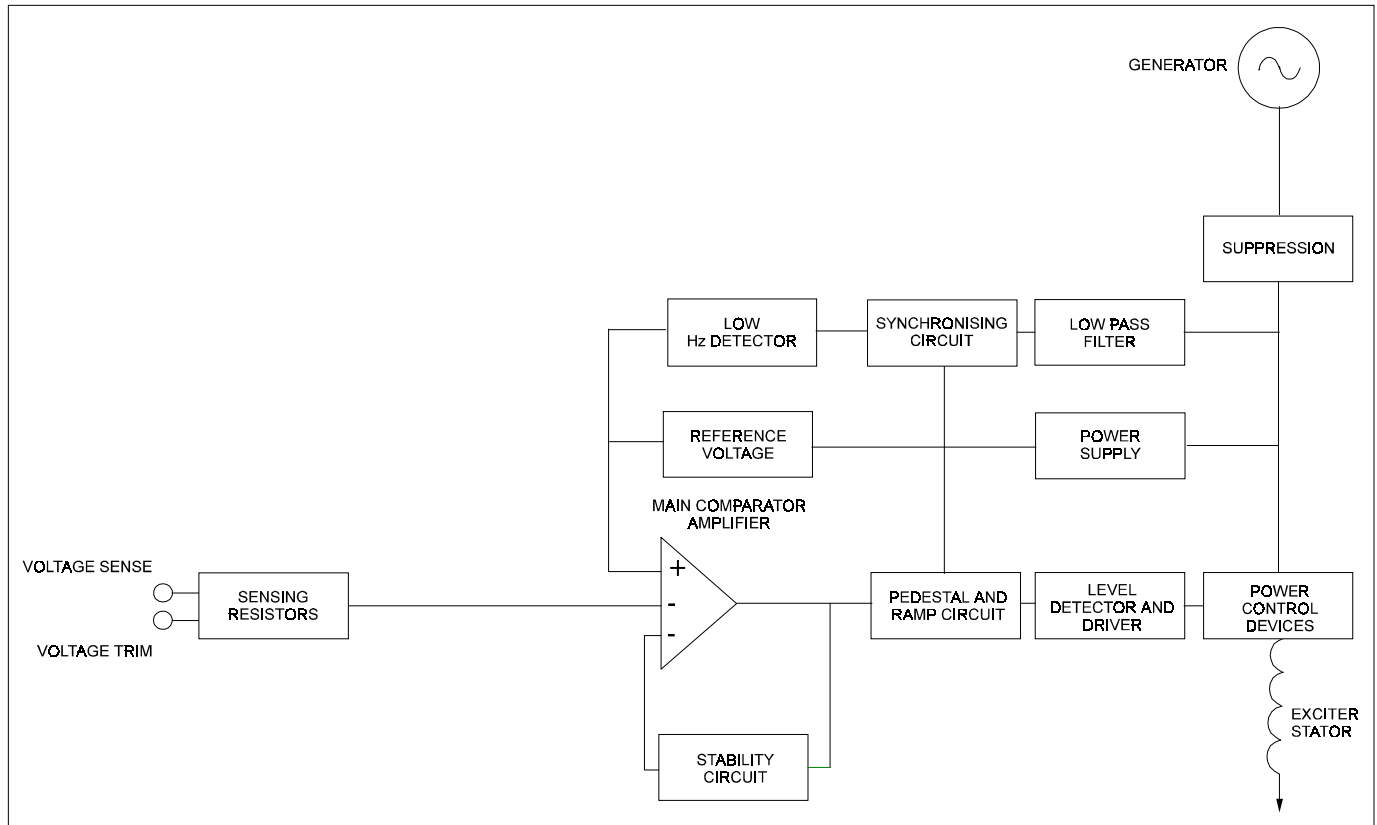

The main functions of the AVR are:

Sensing Resistors take a proportion of the generator output voltage and attenuate it. This input chain of resistors includes the range potentiometer and hand trimmer which adjust the generator voltage. An operational precision rectifier converts the a.c. for further processing.

Main Comparator/Amplifier compares the sensing voltage to the "reference voltage" and amplifies the difference (error) to provide a controlling signal for the power devices. The "pedestal and ramp" circuit and "level detector and driver" infinitely control the conduction period of the output device over each half cycle (phase control), and hence provide the exciter with the required power to maintain the generator voltage within specified limits. The **stability circuit** provides adjustable negative ac feedback to ensure good steady state and transient performance of the control system.

Low Hz detector measures the period of each electrical cycle and causes the reference voltage to be reduced approximately linearly with speed below a presettable threshold. A Light Emitting Diode gives indication of underspeed running.

Synchronising circuit provides a short pulse at zero crossing at each half cycle and is used to synchronise the underspeed and pedestal and ramp circuit to the generator waveform. The circuit is preceded by a low **pass filter** to prevent false zero crossing pulses caused by distorted waveforms.

Power devices are configured as half wave thyristor and freewheel diode to vary the amount of exciter field current in response to the error signal produced by the main comparator.

Suppression components are included to prevent sub cycle voltage spikes damaging the AVR components and also to reduce the amount of AVR thyristor noise on the main terminals of the generator.

Power Supply components consist of zener diodes with dropper resistor and smoothing to provide the required voltages for the integrated circuits and reference voltage.

FITTING AND OPERATING

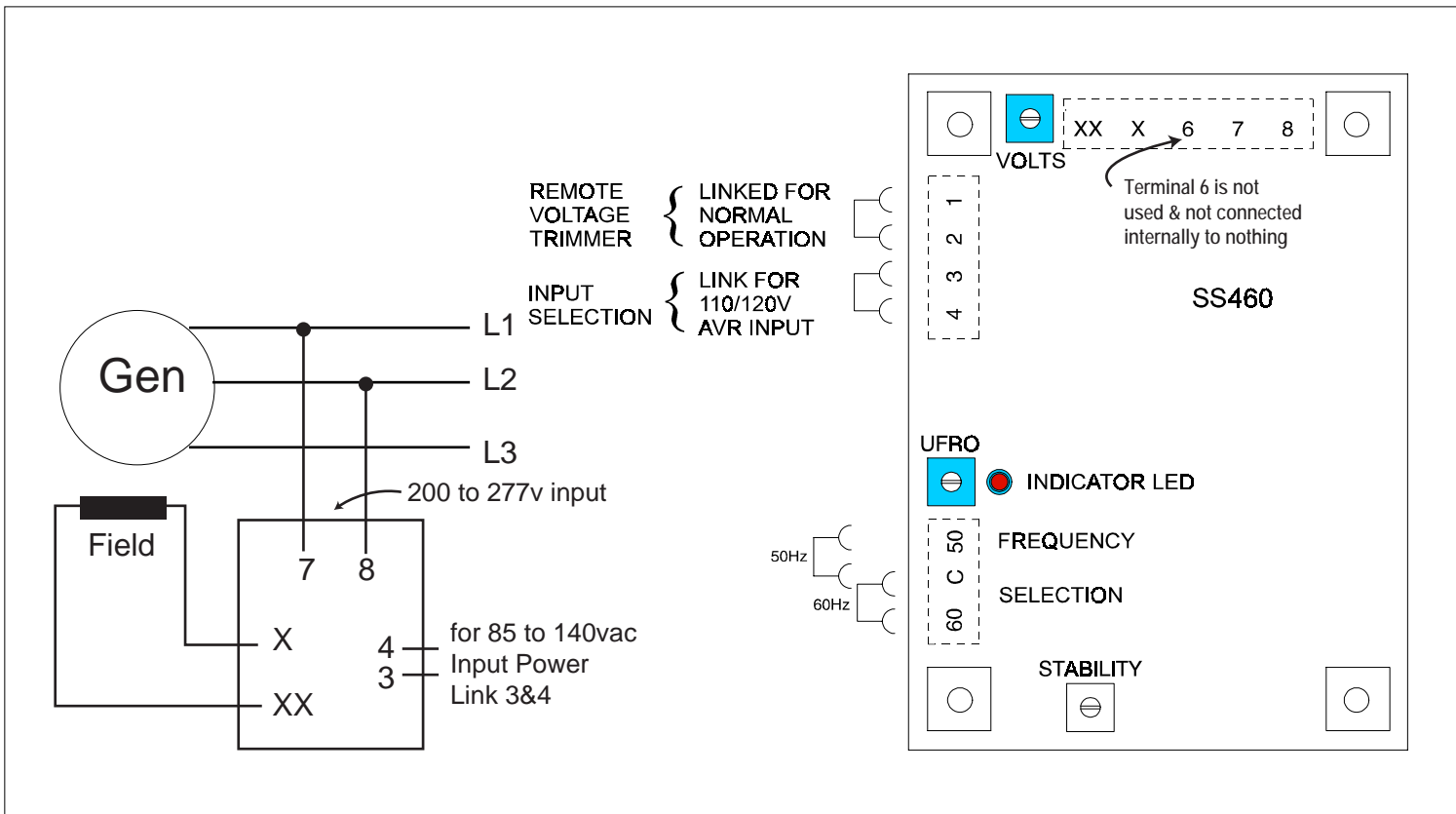

SUMMARY OF AVR CONTROLS		
CONTROL	FUNCTION	DIRECTION
VOLTS STABILITY UFRO	TO ADJUST GENERATOR OUTPUT VOLTAGE TO PREVENT VOLTAGE HUNTING TO SET UNDER FREQUENCY ROLL OFF KNEE POINT	CLOCKWISE INCREASES OUTPUT VOLTAGE CLOCKWISE INCREASES STABILITY OR DAMPING EFFECT CLOCKWISE REDUCES THE KNEE POINT FREQUENCY

The AVR is fully encapsulated to ensure long-trouble-free operation. It is usually fitted on a panel of the terminal box. It can also be separately fitted in a switchboard

ADJUSTMENT OF AVR CONTROLS

VOLTAGE ADJUSTMENT

The generator output voltage is set at the factory, but can be altered by careful adjustment of the volts control on the AVR board, or by the external hand trimmer if fitted. Terminals 1 and 2 on the AVR will be fitted with a shorting link if no hand trimmer is required. Terminals 3 and 4 are used for low voltage only, and are linked only for special low voltage applications.

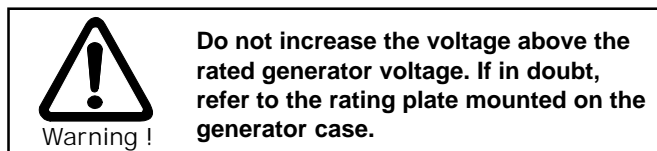

If a replacement AVR has been fitted or re-setting of the VOLTS

adjustment is required, proceed as follows:

- 1) Before running generator, turn VOLTS control fully anti-clockwise.
- 2) Turn remote volts trimmer (if fitted) to midway position.
- 3) Turn STABILITY control to midway position.
- 4) Connect a suitable voltmeter (0-300V ac) across line to neutral of the generator.
- 5) Start generator set, and run on no load at nominal frequency e.g. 50-53Hz or 60-63Hz.
- 6) If the red Light Emitting Diode (LED) is illuminated, refer to the Under Frequency Roll Off (UFRO) adjustment.
- 7) Carefully turn VOLTS control clockwise until rated voltage is reached.
- 8) If instability is present at rated voltage, refer to stability adjustment, then re-adjust voltage if necessary.
- 9) Voltage adjustment is now completed.

STABILITY ADJUSTMENT

The AVR includes a stability or damping circuit to provide good steady state and transient performance of the generator.

The correct setting can be found by running the generator at no load and slowly turning the stability control anti-clockwise until the generator voltage starts to become unstable.

The optimum or critically damped position is slightly clockwise from this point (i.e. where the machine volts are stable but close to the unstable region).

UNDER FREQUENCY ROLL OFF (UFRO) ADJUSTMENT

The AVR incorporates an underspeed protection circuit which

gives a volts/Hz characteristic when the generator speed falls below a presettable threshold known as the "knee" point.

The red Light Emitting Diode (LED) gives indication that the UFRO circuit is operating.

The UFRO adjustment is preset and sealed and only requires the selection of 50/60Hz using the jumper link.

For optimum setting, the LED should illuminate as the frequency falls just below nominal, i.e. 47Hz on a 50Hz system or 57Hz on a 60Hz system.

