

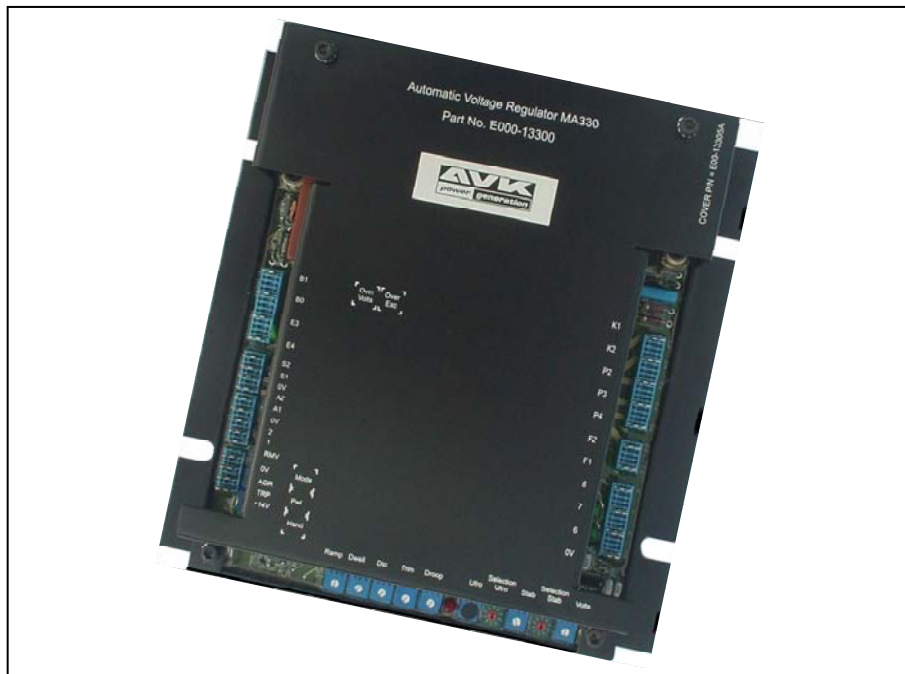

MA330 AUTOMATIC VOLTAGE REGULATOR Specification, Installation, and Adjustments Manual



Safety Precautions

Before installing, adjusting or using this product it is important that you read the contents of this document, the contents of the generator instruction manual and also become familiar with the equipment. Observe all Caution and Warning notices:

- Caution** **Caution refers to a hazard or unsafe method or practice which can result in product damage.**
- Warning** **Warning refers to a hazard or unsafe method or practice which can result in injury or death.**

Many accidents occur because of failure to follow basic rules and precautions. Electric shock can cause injury or death.

Safe and efficient operation will only be achieved if the equipment is correctly installed, adjusted, operated and maintained.

These instructions have been written for use with the AVR specification as originally supplied with the generator.

Ensure that the installation meets all applicable safety regulations and codes-of-practice.

All work and adjustments must be carried out by skilled technicians using instruments and equipment which are regularly checked for safety.

Disable engine starting systems, automatic closure circuits and isolate anti-condensation heaters before carrying out any maintenance work.

Never expose 'LIVE' connections unless you have created a safe working area around you. Make sure you have made all other persons in the immediate area fully aware of what you are doing and ensure that there is someone in the area that is conversant with the first aid requirements of a victim of an electrical shock.

Do not operate the equipment with the protective covers removed

- Warning:** **Reservoir capacitors within the AVR can store charge after stopping the generator and can remain present on terminals K1, K2, F1, F2, B0 and B1 for up to four minutes. Do not work on the machine wiring or the AVR assembly until this time has elapsed. Do not attempt to force discharge the capacitors.**

Contents

SAFETY PRECAUTIONS	2
GENERAL DESCRIPTION	4
ELECTROMAGNETIC COMPATIBILITY	4
TECHNICAL SPECIFICATION	5
BLOCK DIAGRAM.....	6
BASIC OPERATION.....	6
AVR CONTROLS.....	8
SUMMARY OF AVR CONTROLS	8
STABILITY TABLE.....	8
AVR CHECKS.....	9
VOLTAGE AND FREQUENCY CHECK	9
AVR SETTINGS.....	9
FREQUENCY SELECTION	9
STABILITY SELECTION - STABILITY SELECTION SWITCH - SELECT POSITION 6.	9
GENERATOR SET TESTING.....	9
INITIAL START-UP.....	9
LOCATION DRAWING, CONTROL AND CONNECTION	9
AVR ADJUSTMENTS.....	10
VOLTAGE [VOLTS] ADJUSTMENT.....	10
STABILITY [STAB] ADJUSTMENT	10
RAMP ADJUSTMENT:	11
UNDER FREQUENCY ROLL OFF [UFRO].....	11
V/Hz SLOPE [DIP] ADJUSTMENT:.....	12
DROOP ADJUSTMENT	12
TRIM ADJUSTMENT	13
OVER VOLTAGE PROTECTION ADJUSTMENT:	13
OVER EXCITATION ADJUSTMENT:	14
PWL (PULSE WIDTH LIMIT):.....	14
MODE AND HAND:	14
FAULT FINDING CHART	15
TYPICAL WIRING DIAGRAM.....	16

General Description

The MA330 AVR is a three phase full wave, pulse width modulated type automatic voltage regulator (AVR) and forms part of the excitation system of the brushless generator.

Excitation power is derived from a shaft mounted three phase permanent magnet generator (PMG) which provides an isolated supply to the AVR control circuits. The independent PMG assures the performance of the AVR against non-linear loads and reduces the radio frequency interference on the generator terminals. The PMG supply enables the generator to maintain current into a short circuit.

The AVR senses the voltage on the main generator winding either directly or via transformers. This signal is used to control the power fed to the exciter stator (and hence the main rotor) to maintain the generator output voltage within the specified limits, compensating for load, speed, temperature and power factor.

Three phase RMS sensing is employed for superior voltage regulation.

Provision is made for the connection of a remote trimmer allowing the user fine control of the generator output voltage.

Soft-start circuitry is included to provide a smooth controlled build up of generator output voltage.

A frequency measuring circuit continually monitors the speed of the generator to provide protection of the excitation system. This operates by reducing the generator output voltage proportionally with speed below an adjustable threshold. A further enhancement of this feature is an adjustable 'volts per Hertz' slope (dip) and a delayed voltage recovery (dwell) both designed to improve speed recovery time when the generator is used in conjunction with turbo-charged engines.

Protection circuitry is included which cuts off the excitation power in event of over-voltage or over-excitation caused by malfunction or excessive load on the generator. The over-voltage protection requires additional wiring between the AVR and the main generator windings. An output signal is produced which can be used to trip an external protection device in the event of over-voltage or over-excitation. Both conditions remain latched until the generator has stopped.

Excitation limiting [PWL] allows control over the amount of current flowing during overload of the generator output.

Electromagnetic Compatibility

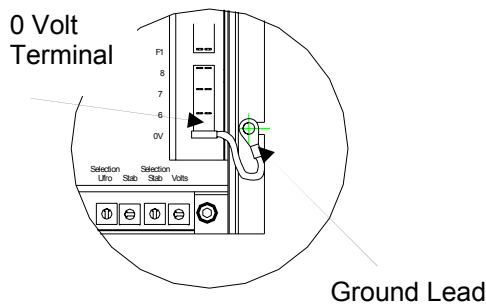

All aspects of EMC have been type tested, assessed and recorded in a Technical Construction File as required by EEC Directive 89/336/EEC. Any modifications to the generator and/or its wiring could impact on compatibility within the electromagnetic environment and are therefore the responsibility of the assembler.

All metalwork of the AVR is intended for safe operation at earth/ground potential. A separate ground lead (2.5mm²) should connect the AVR terminal 0V to the nearest control box earth point.

Technical Specification

Sensing input:	Voltage	170 ... 250 Vac max
	Frequency	50 ... 60 Hz nominal
	Phase	1 or 3
Power input (PMG):	Wire	2 or 3
	Voltage	140 ... 220 Vac max
	Frequency	100 ... 120 Hz nominal
Output:	3 Phase, 3 Wire.	
	Voltage	180 V dc (max @ 1800 rpm)
	Current	Continuous 6 A Intermittent 12 A for 10s
Regulation:	Resistance	15Ω minimum
Thermal drift:	+/- 0.5% RMS (inclusive of 4% engine governing)	
Soft start ramp time:	0.015%V per degree centigrade	
Typical system response: (AVR and generator)	0.5 ... 4s	
External voltage adjustment:	Exciter current to 97% - 300 ms	
Under frequency protection:	+/-10% with 5kΩ/1 watt trimmer	
Unit power dissipation:	Set point	95% Hz
	Slope	100 ... 300% down to 25 Hz
	Max. Dwell	10 % Volts/s recovery
Accessory input:	30 watts max	
Quadrature droop sensitivity:	Maximum +/- 5Vdc	
	+/-1 volt input = +/- 5% generator volts	
Excitation limit:	0.04 Amps for 5% droop @ zero power-factor	
Over excitation protection:	Setting range	50 ... 100%
	Setting range	60 ... 90 V dc (factory set = 75V)
	Time delay inverse time >125 % setting = 10s max	
	External trip coil circuit voltage 10 ... 60 V dc	
Over-volts protection:	External trip coil circuit resistance 50 ... 100 ohms	
	Setting range	250 ...350 volts (factory set = 300V)
	Time delay	1s fixed
	External trip coil circuit voltage 10 ... 60 V dc	
Environmental:	External trip coil circuit resistance 50 ... 100 ohms	
	Vibration	5...10Hz 1mm pk 10...100Hz 50mm/s
	RMS	100Hz...300Hz 4.4g pk
	Relative humidity	0-70°C 95%
EMC:	Operating temperature	-40 ... +70°C
	Storage temperature	-55 ... +80°C
	EN 61000-6-2; 2001 (Industrial Emissions)	
Compatible Accessories:	EN 61000-6-4; 2001 (Industrial Immunity)	
	Power Factor Controller.	
	Diode Failure Detector	
	Remote Control Interface	

Block Diagram

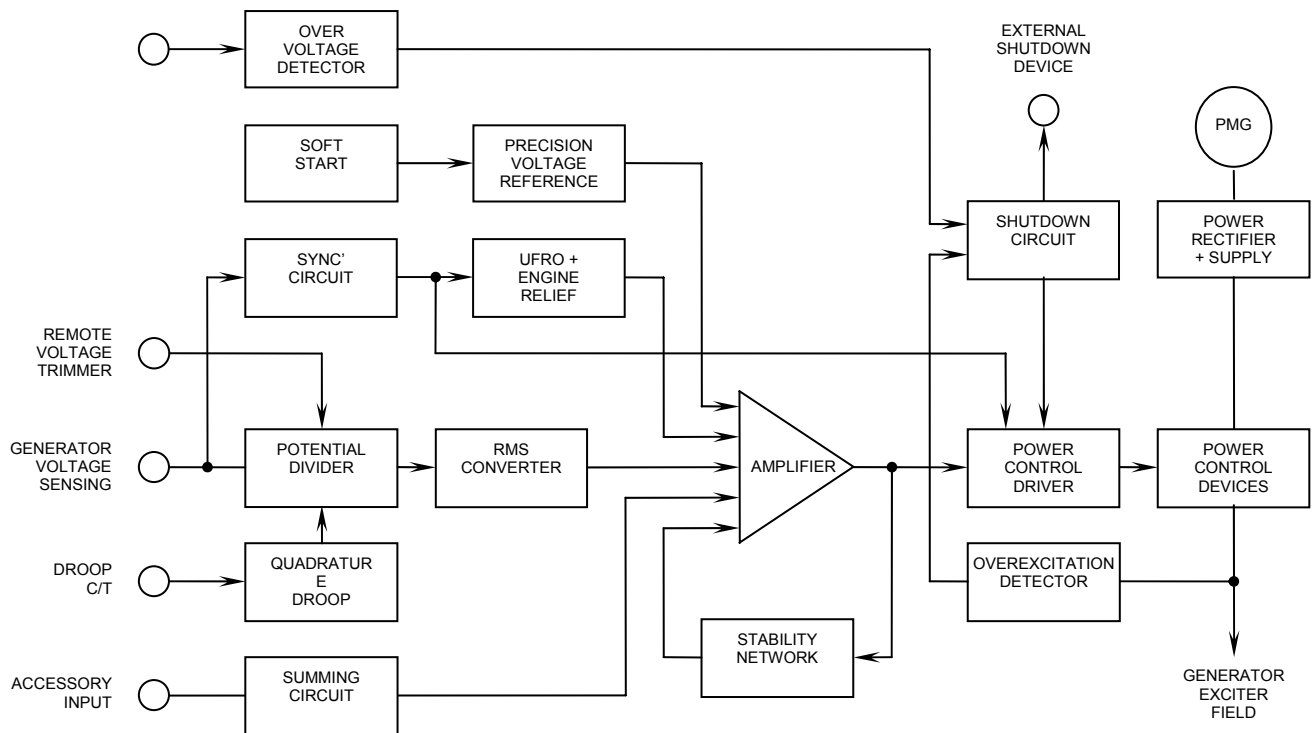

Basic Operation

The main functions of the AVR are as follows:-

Potential divider takes a proportion of the generator output voltage and attenuates it for use by the RMS converter and main control amplifier. Provision is made to allow the attenuation ratio to be adjusted by the internal AVR 'Volts' potentiometer or an external hand trimmer if required. This allows adjustment of the generator output voltage.

Quadrature droop circuit converts the current input from a C/T into a voltage which is mixed with the incoming sensing voltage. The result of the vector mixing is a modification of the output from the RMS converter. The phase position of the C/T is arranged so as to provide for reactive load sharing of paralleled generators.

RMS converter converts the incoming a.c. signals from the potential divider into a d.c. signal representing the 'True RMS' value of the generator output voltage waveform.

Summing circuit provides an interface between the AVR and accessories (usually a power-factor controller).

Power supply components consist of wound components, resistors, regulator diodes and smoothing capacitors all configured to provide the required voltages for the various electronic circuits.

Precision voltage reference is a highly stable temperature compensated voltage reference used by several circuits within the AVR. The performance of this device will determine the overall temperature stability of the main generator output.

Soft start circuit overrides the precision voltage reference during generator run-up to provide a linear rising voltage with time. This helps reduce any start-up voltage overshoot. The speed of the start-up is set on the ramp control.

Amplifier compares the RMS value of the sensing voltage and the precision reference voltage to produce an error signal. This error is then amplified to provide a controlling signal for the AVR power device.

Stability network provides adjustable feedback to ensure optimum steady state and transient performance of the generator output.

Power control driver controls the conduction period of the output device using pulse width modulation techniques.

Power control devices vary the amount of current flowing in the exciter field in response to the signals produced by the amplifier and power control driver.

Sync circuit provides the necessary signals to synchronise the Under Frequency Roll Off (UFRO) and power control circuits to the generator output period. The UFRO circuit uses this signal as a measure of generator / engine frequency.

UFRO circuit measures the period of each electrical cycle and reduces the reference voltage linearly with speed below an adjustable threshold. A light emitting diode (LED) gives indication of under-speed operation.

Engine relief circuit provides adjustment for increasing the gradient of V/Hz slope in order to aid engine recovery after the application of a step load (kW). A "Dwell" feature is included which can delay the rate of recovery of generator volts after application of load and provide further assistance for engine speed recovery.

Overexcitation detector continuously monitors the excitation voltage and provides signals to shutdown the AVR power output device and trip an optional external device if a threshold setting is exceeded. An produces a latched shutdown and requires the generator to be stopped for reset.

A **timer** is included in the circuit to prevent nuisance tripping during transient overloads. The duration of the timer is based on an inverse time characteristic with a minimum trip time of between 8 and 10seconds.

Over-voltage detector continuously monitors the voltage at two dedicated AVR terminals and provides signals to shut down the AVR power output device and trip an optional external device if a threshold setting is exceeded. An over-voltage condition produces a latched shutdown and requires the generator to be stopped for reset.

A fixed one second timer is included in the circuit to prevent nuisance tripping during transient over-voltages.

Power rectifier converts the three phase output from the PMG into a high power d.c. supply for the generator exciter.

AVR Controls

Controls shown [in brackets] are factory sealed after test and should not normally require adjustment.

Summary of AVR Controls		
Control:	Function:	Direction:
VOLTS	To adjust generator output voltage	Clockwise increases output voltage
STAB (stability)	To prevent voltage hunting	Clockwise increases the damping effect
STAB SEL (selection)	To optimise transient performance	See 'Stability Table' below
[UFRO]	To set Under Frequency Roll Off knee point	Clockwise reduces knee point frequency
UFRO SEL (selection)	To set UFRO setting range	Switch position 5 = 50 Hz 6 = 60 Hz
DROOP	To set voltage droop to 5% at 0 PF	Clockwise increases the droop
TRIM	To match AVR input to Accessory output	Clockwise increases AVR sensitivity
DIP	To adjust frequency related voltage dip	Clockwise increases the dip
DWELL	To set the rate of voltage recovery time	Clockwise lengthens the recovery time
RAMP	To set the soft start voltage ramp time	Clockwise lengthens the ramp time
HAND	For manual excitation control (mode=4)	Clockwise increases excitation
PWL (pulse width limit)	To set the maximum excitation voltage limit	Clockwise increase the voltage limit
MODE	To select 'AVR' or 'Hand' control mode	8 = AVR control. 4 = Hand control
[O/VOLTS]	To set the over-voltage protection trip level	Clockwise increases the trip level
[O/EXC]	To set the over-excitation protection trip level	Clockwise increases the trip level

Stability Table	
Switch position:	
0 = under 100kW	5 = 2500 ... 3200 kW
1 = 100 ... 500kW	6 = 3200 ... 4000 kW
2 = 500 ... 1000kW	7 = 4000 ... 4800 kW
3 = 1000 ... 1800kW	8 = not used
4 = 1800 ... 2500 kW	9 = not used

AVR Checks

Voltage and Frequency Check

Check that the voltage and frequency levels required for the generating set application are within the range indicated on the generator nameplate.

AVR Settings

To adjust AVR settings remove the housing cover, and refer to the label inside cover for guidance of adjustment potentiometers and selection link location. Fig 2 also shows AVR layout.

Most of the AVR adjustments are factory set in positions which will give satisfactory performance during initial running tests. Subsequent adjustment may be required to achieve optimum performance of the set under operating conditions. Refer to section 4.7 for details.

The following 'jumper' connections on the AVR should be checked to ensure they are correctly selected for the generating set application:

Frequency selection - UFRO switch selection to suit the operating frequency.

Initial Switch Position	4P/50Hz	corresponds to 1500 r.p.m.	5
	4P/60Hz	corresponds to 1800 r.p.m.	6

Stability selection - Stability selection switch - select position 6.

Generator Set Testing

Warning During testing it may be necessary to remove covers to adjust controls exposing 'live' terminals or components. Only personnel qualified to perform electrical service should carry out testing and/or adjustments.

Initial Start-Up

On completion of generating set assembly and before starting the generating set ensure that all engine manufacturer's pre-running procedures have been completed, and that adjustment of the engine governor is such that the generator will not be subjected to speeds in excess of 125% of the rated speed.

Location drawing, control and connection

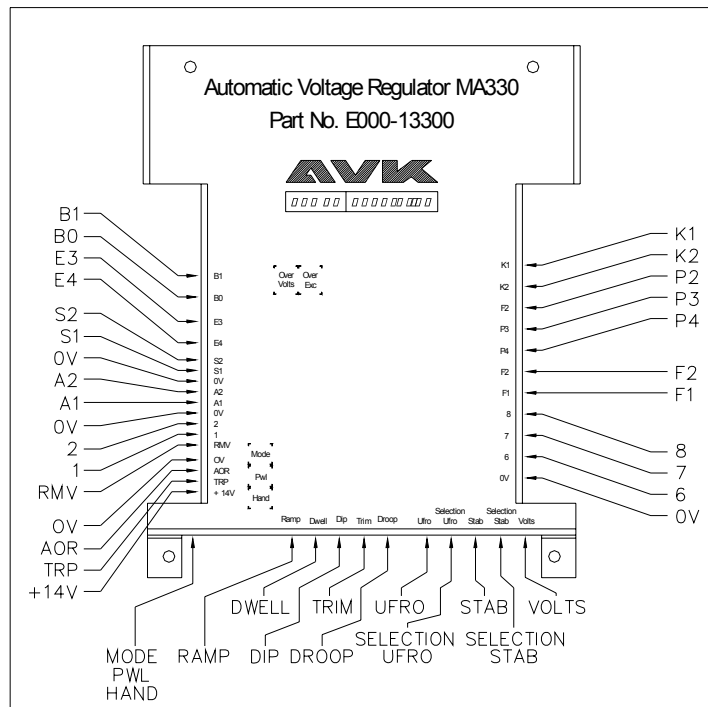

AVR Adjustments

Voltage [VOLTS] Adjustment

The generator output voltage is set to the customer requirements at the factory but can be altered by careful adjustment of the [VOLTS] control or by the external hand trimmer (if fitted).

Important **Do not increase the voltage above the rated voltage of the generator**
..... If in doubt, refer to the generator rating plate.

If a replacement AVR has been fitted or re-setting of the voltage adjustment is required, proceed as follows:

1. Before running the generator:
2. Ensure that a suitable voltmeter is available in order to measure the generator output voltage.
3. Turn the [VOLTS] control fully anti-clockwise and turn the external hand trimmer (if fitted) to its midway position.
4. Turn the [STAB] control to its midway position.
5. Start the generator set, and run at a no-load condition at nominal frequency e.g. 50-53 Hz or 60-63 Hz.
6. If the red light-emitting-diode (LED) is illuminated (constant), refer to the notes on under frequency roll off adjustment.
7. If the LED is flashing then refer to the notes on over-excitation and over-voltage protection adjustments.
8. Carefully turn the [VOLTS] control clockwise until rated voltage is reached.
9. If instability is present at rated voltage, refer to the notes on stability adjustment, and then re-adjust the generator voltage if necessary.

Voltage adjustment is now complete.

Stability [STAB] Adjustment

The AVR includes a stability (damping) circuit to ensure good steady state and transient performance of the generator. A switch is provided to change the response of the stability circuit to suit different frame size generators and applications.

The correct setting of the stability control can be found as follows:

1. Before running the generator:
2. Select the appropriate [STAB SEL] switch setting for the generator frame size. (see stability table)
3. Turn the [STAB] control clockwise of its midway position (i.e. approx 75%)
4. Run the generator at no load
5. Slowly turn the [STAB] control anti-clockwise until the generator voltage become slightly unstable. (The optimum position is slightly clockwise from this point.
6. Slowly return the [STAB] control clockwise until the voltage is again stable. This is the correct running position.

Stability adjustment is now complete.

Ramp adjustment:

The AVR includes a soft start circuit to control the rate of voltage build-up when the generator runs up to speed. This is normally pre-set to give a voltage ramp-up time of approximately three seconds. If required, this can be adjusted between the limits defined in the specification.

With the [RAMP] control fully counter-clockwise the AVR ramp time is approximately 0.5s. With the [RAMP] control fully clockwise the value is extended to approximately 4.0s.

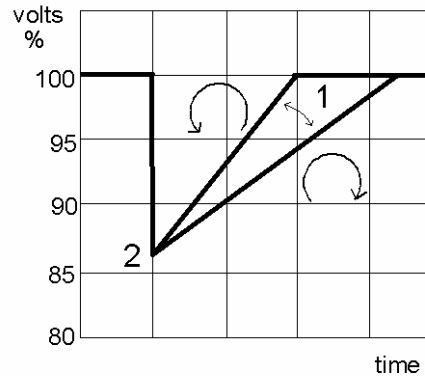

1) Adjustable slope 2) Instant of load application

Under Frequency Roll Off [UFRO]

The AVR incorporates an under speed protection circuit which gives a 'Volts per Hertz' characteristic when the generator speed falls below an adjustable threshold (knee point). Under normal circumstances it will not be necessary to adjust the factory setting and a jumper link allows selection of either 50Hz or 60Hz operation. A red light emitting diode (LED) gives an indication that the UFRO circuit is in operation

Should it be necessary to adjust the UFRO 'knee' set-point then proceed as follows: (Note; it will be necessary to adjust the generator/engine speed during this procedure).

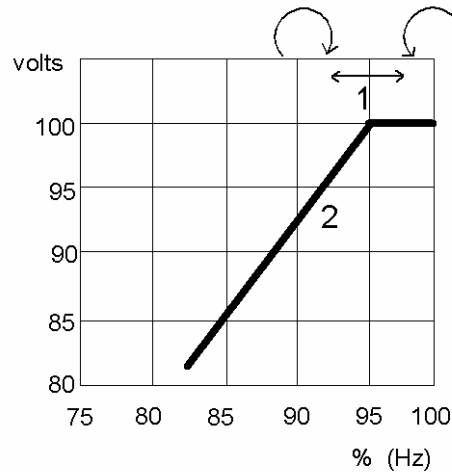

1 Knee point. 2 Typical slope.

1. Run the generator at no load and at nominal frequency. (50Hz or 60Hz)
2. Turn the [UFRO] control fully clockwise (the red LED should be 'off').
3. If the LED is flashing, refer to section detailing Over Excitation and Over-Voltage protection adjustments.
4. Run the generator at no load and at the required 'knee' frequency. (typically 47Hz or 57Hz)
5. Turn the [UFRO] control slowly counter-clockwise until the LED illuminates.
6. Return the [UFRO] control slowly clockwise until the LED just turns off.
7. The setting can be checked by varying the generator speed above and below the knee point and observing the LED: (Hz above = LED OFF; Hz below = LED ON)

UFRO adjustment is now complete.

V/Hz slope [DIP] adjustment:

The dip adjustment allows the user to have control over the amount of frequency related voltage dip upon the application of load. This feature is mostly used when the generator is coupled to turbo charged engines with limited step load acceptance capability. The feature only operates when the speed is below the UFRO knee point and works by increasing the V/Hz slope to give greater voltage dip (hence kW) in proportion to falling speed.

With the [DIP] control fully counter-clockwise the generator voltage characteristics will follow the minimum V/Hz line as the frequency falls below nominal. (1%Hz = 1%Volts)

Turning the [DIP] control clockwise creates a greater slope in the V/Hz characteristic (to a maximum of 1%Hz = 3%Volts) thus aiding engine speed recovery.

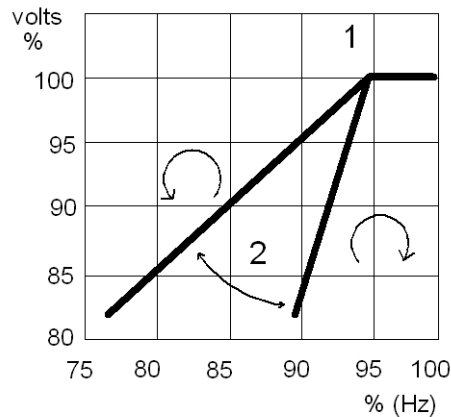

1) Knee point 2) Adjustable slope

Dwell [DWELL] adjustment

The dwell function introduces a time delay between the recovery of voltage and recovery of speed. The purpose of the time delay is to reduce the generator kW below the available engine kW during the recovery period, thus allowing an improved speed recovery. Again this control is only functional below the "knee point", i.e. if the speed stays above the knee point during load switching there is no effect from the DWELL function setting.

This feature is mostly used when the generator is coupled to turbo charged engines with limited block load acceptance.

With the DWELL control fully anti-clockwise, the generator voltage will follow the V/Hz line. Turning the DWELL control clockwise increase the delay time between speed recovery and voltage recovery. Turning the [DWELL] control clockwise decreases the rate of voltage recovery as the engine speed recovers. This further aids the engine speed recovery by reducing the load on the engine whilst the generator shaft accelerates back to full speed.

The voltage recovery (hence engine loading) can be 'held back' for several seconds using this feature.

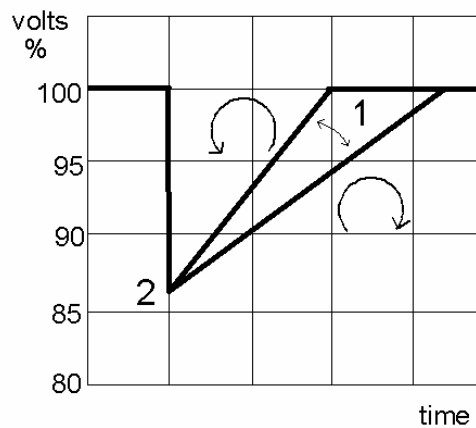

1) Adjustable slope 2) Instant of load application

Droop adjustment

Generators intended for parallel operation are fitted with a quadrature droop current transformer (CT) which provides a signal for the AVR, allowing each generator to share reactive current.

Caution It is important to have the Quadrature Droop Current Transformer polarity correct before paralleling is attempted. With CT 'P1' facing the generator star connection, the following conventions should be used.

Generator rotation: (viewed on drive end)

Clockwise	CT S1 to AVR S1 CT S2 to AVR S2.
Counter-Clockwise	CT S1 to AVR S2 CT S2 to AVR S1.

It is important to match the generator no-load voltages to within 1% of each other, to ensure good reactive load sharing.

The droop adjustment is normally pre-set in the works to give 5% voltage droop at full-load zero power-factor. ($\cos\phi = 0$) With the control fully anti-clockwise there is no droop.

If droop needs to be reset for any reason, then the following procedure should be followed:

1. Run the generator at 50% rated current at any power-factor between 0.8 lagging and 1.0 (unity). Ensure that the generator rated current value used is the maximum rating for the frame-size without any derate factor. If in doubt, check with the factory.
2. Measure the voltage on AVR terminals S1 and S2 (this should be between 0.2 and 1.9 Vac)
Calculate: 20

measured S1:S2 voltage
3. This result should be between 0 and 100 and indicates the required position (in % rotation) of the [DROOP] control. If the result is greater than 100 then it suggests that the droop CT ratio is incorrect.
4. Set the [DROOP] control to this value (0 ... 100%), where 0% = fully counter-clockwise and 100% = fully clockwise.

Droop adjustment is now complete.

Trim adjustment:

An auxiliary input is provided to connect to accessories (usually a Power-Factor Controller) and is designed to accept d.c. signals up to +/- 5 volts.

Caution Any signal connected to this input must be fully floating and earth free.

The d.c. signal presented to this input adds to, or subtracts from the AVR sensing circuit input and allows the accessory to have an influence on the generator excitation.

The [TRIM] control allows the user to determine how much control the accessory has over the AVR. With the [TRIM] control fully clockwise the accessory has full control. With the [TRIM] control fully anti-clockwise the accessory has no control and can be of use during equipment commissioning.

Over Voltage protection adjustment:

The AVR includes protection circuitry to remove generator excitation in the event of over-voltage. Separate terminals are provided for the over-voltage sensing circuit (E3, E4) and the shut-down signal acts on the AVR power control device.

Provision is made for the (optional) connection of an external device to cut off the excitation power directly. This provides extra protection in the event of a malfunction of the AVR power control device. The details of this output are given in the Technical Specification.

The over-voltage adjustment is set and sealed at the factory but can be reset if required. Clockwise rotation of the [O/VOLTS] control increases the voltage trip level. An over-voltage trip condition is indicated by a flashing red LED (which also indicates over excitation trip and UFRO operation). The generator must be stopped to reset an over-voltage trip condition.

To assist in resetting the [O/VOLTS] control the LED is set to 'ON' whenever the voltage threshold is exceeded. The AVR is shutdown (indicated by a flashing LED) only after the appropriate time delay.

Over excitation adjustment:

The AVR includes protection circuitry to remove generator excitation in the event of over-excitation. This condition is usually a result of overload and can damage the rotor components within the generator.

Provision is made for the (optional) connection of an external device to cut off the excitation power directly. This provides extra protection in the event of a malfunction of the AVR power control device. The details of this output are given in the Technical Specification.

The over-excitation adjustment is set and sealed at the factory but can be reset if required. Clockwise rotation of the [O/EXC] control increases the excitation trip level. An over-excitation trip condition is indicated by a flashing red LED (which also indicates over-voltage trip and UFRO operation). The generator must be stopped to reset an over-voltage trip condition.

To assist in resetting the [O/EXC] control the LED is set to 'ON' whenever the excitation threshold is exceeded. The AVR is shutdown (indicated by a flashing LED) only after the appropriate time delay.

PWL (Pulse Width Limit):

The [PWL] control is provided to enable a limit to be placed on the maximum excitation available from the AVR. This could be used to limit short-circuit current capability if required. This control is factory set to the fully clockwise position which represents 'no limit' to the AVR output.

Mode and Hand:

These controls are for Service Engineers use only.

Fault Finding Chart

Fault	Action
No voltage build-up when starting set	Follow separate excitation or residual voltage tests.
Loss of voltage when set running	First stop and re-start set. If no voltage or voltage collapses after short time, follow the Separate Excitation Test Procedure.
Generator voltage high followed by collapse	Check sensing leads to AVR. Check isolating transformer secondary output - Refer to Separate Excitation Test Procedure.
Voltage unstable, either on no-load or with load	Check speed. If correct check "UFRO" setting Refer to Load Testing,
Voltage low on load	Check speed. If correct check "UFRO" setting. Refer to Load Testing,
Phase voltages unbalanced	Check stator winding and cables to main circuit breaker. Refer to unbalanced Main Terminal Voltages, In the Installation Manual
Excessive voltage/speed dip on load switching	Check governor response - Refer to generating set manual. Check "DIP" setting – refer to Load Testing.
Sluggish recovery on load switching	Check governor response – Refer to generating set manual. Check "DWELL" setting.

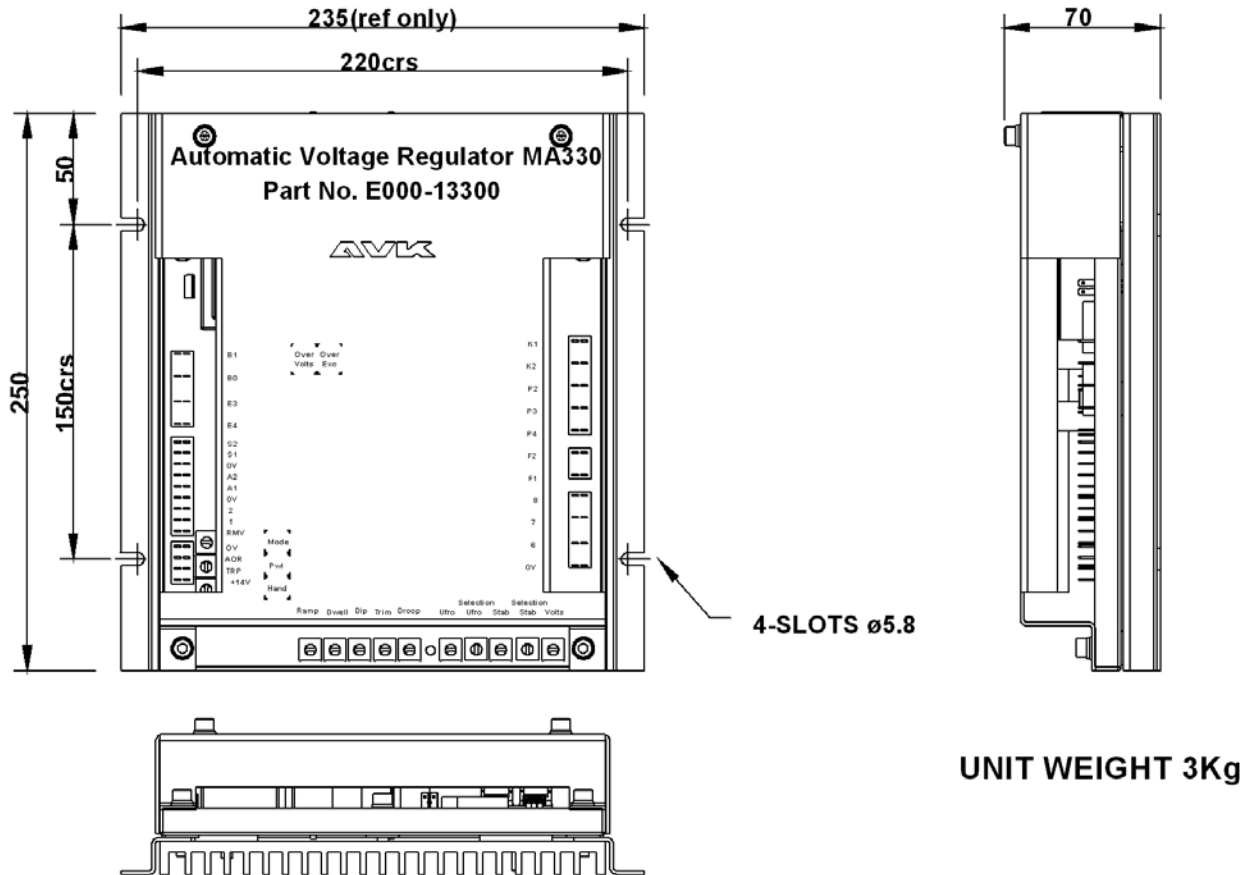

Typical Wiring Diagram

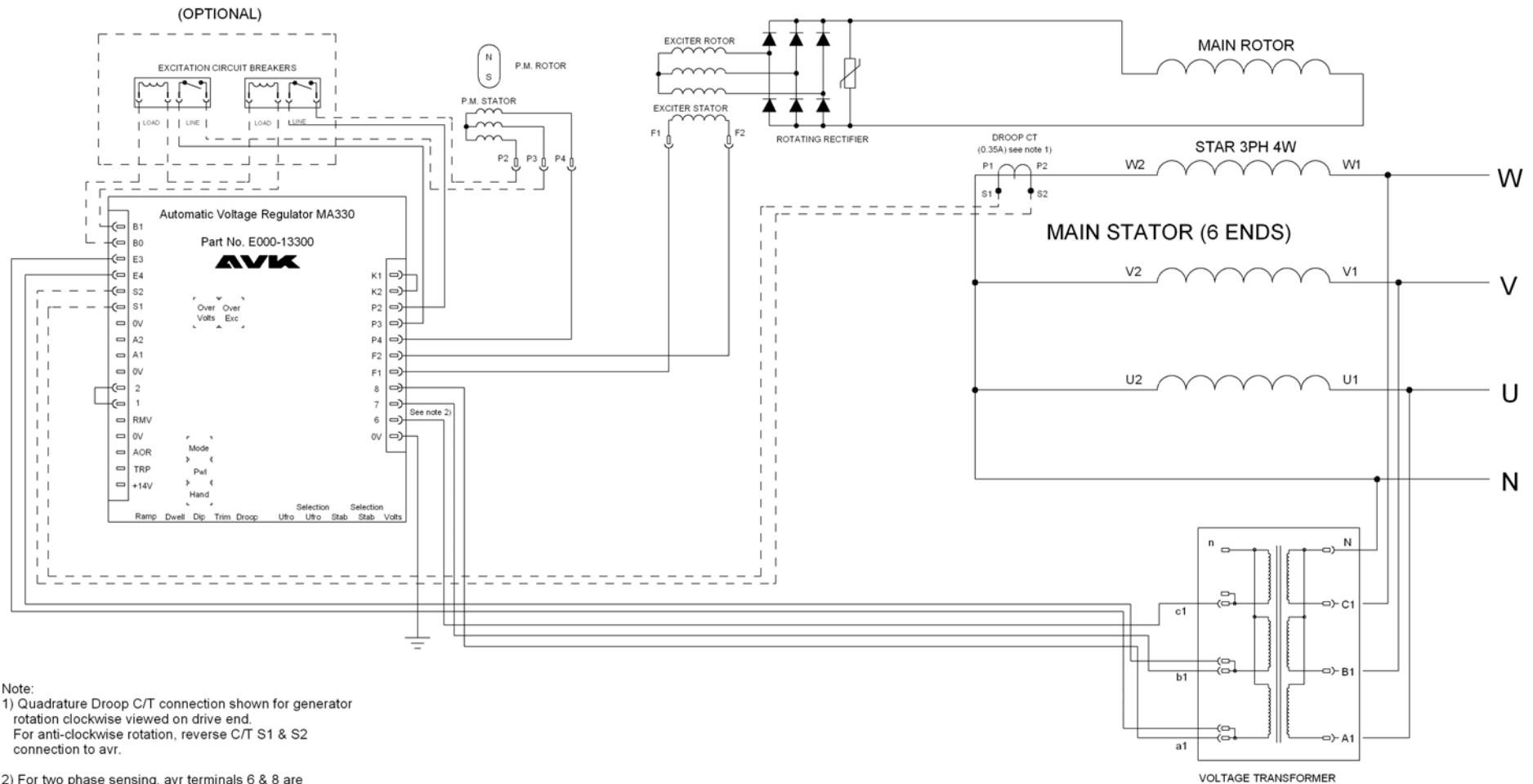

- Note:
- 1) Quadrature Droop C/T connection shown for generator rotation clockwise viewed on drive end. For anti-clockwise rotation, reverse C/T S1 & S2 connection to avr.
 - 2) For two phase sensing, avr terminals 6 & 8 are commoned, with the sensing input then to 6-8 & 7.

AUSTRALIA Tel: +61 2 9680 2299 Fax: +61 2 9680 1545	MEXICO Tel: +52 48 70 44 00 Fax: +52 48 70 44 71
BELGIUM Tel: +32 15 479 170 Fax: +32 15 479 173	NORWAY Tel: +47 229 74444 Fax: +47 229 74445
CANADA Tel: +1 416 259 3741 Fax: +1 416 259 7167	ROMANIA Tel: +40 251 439 600 Fax: +40 251 439 689
CHINA Tel: +86 510 521 6212 Fax: +86 510 521 7673	SINGAPORE Tel: +65 6794 3730 Fax: +65 6898 9065
FRANCE Tel: +33 1 6074 9843 Fax: +33 1 6074 9844	SPAIN Tel: +34 91 498 2000 Fax: +34 91 498 2004
GERMANY AVK Tel: +49 (0) 61 03 50 39 0 Fax: +49 (0) 61 03 50 39 40 AVK Ingolstadt Tel: +49 (0) 8 41/7 92 – 0 Fax: +49 (0) 8 51/7 92 – 250	UK Tel: +44 (0) 1780 484000 Fax: +44 (0) 1780 484100 AVK Tel: +44 (0) 1780 484000 Fax: +44 (0) 1780 484107 Markon Tel: +44 (0) 1572 723811 Fax: +44 (0) 1572 756856
INDIA Pune Board: +91-(0) 20-6624 6700 Direct: +91-(0) 20-6624 6723 Fax: +91-(0) 20-6602 5331 Mobile: +91 98508 32511 Ahmednagar Tel: +91 241 5603464-7 Fax: +91 241 2777494	USA Tel: +1 763 528 7301 Fax: +1 763 574 5082 Dist. Centre Tel: +1 713 672 2801 Fax: +1 713 673 2827 (SALES) David Lanchbery Tel: +1 610 578 9233 Fax: +1 610 578 9244 Steve Sharpe Tel: +1 775 826 1224 Fax: +1 775 826 1225 Tom Varani Tel: +1 262 240 0562 Fax: +1 262 240 0563
ITALY Tel: +39 (0)2 380 00714 Fax: +39 (0)2 380 03664	
JAPAN Tel: +81 3 5999 3355 Fax: +81 3 3994 6029 Nitta Plant: Tel: +81 276 56 7335 Fax: +81 276 56 6075	