

EA08A

Generator Automatic Voltage Regulator Operation Manual

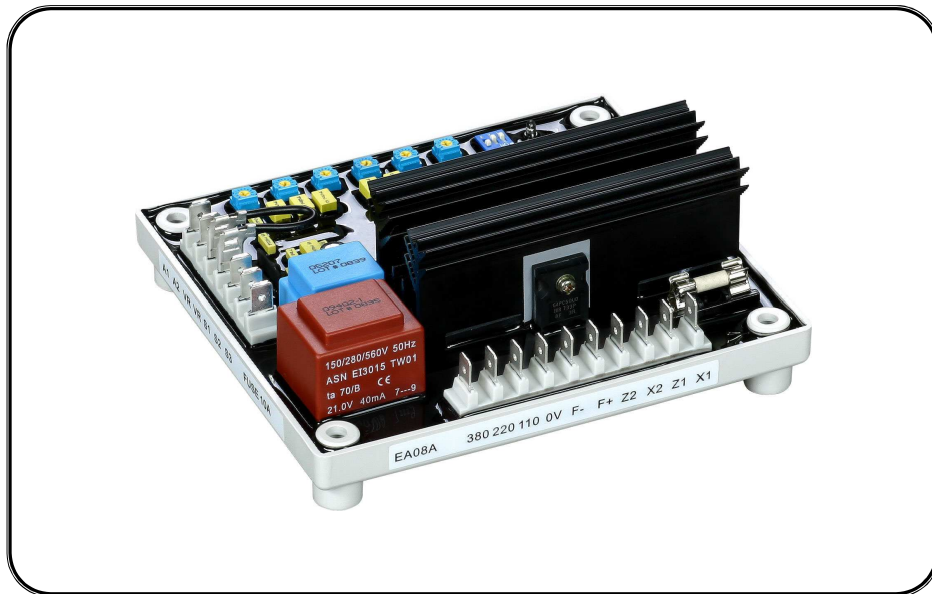

Self Excited Automatic Voltage Regulator
For use in Brushless Full Harmonic or Harmonic and Auxiliary
Winding. Compatible with the Leroy Somer R438 & RS128.



This component must be housed inside alternator terminal box and be fitted by a competent electrical engineer.

SP POWERWORLD LTD
Willows, Waterside, Ryhall, Stamford, Lincs, PE9 4EY, UK
Tel: +44 1780 756872 - Email: info@sp-powerworld.com
www.sp-powerworld.com

1. INTRODUCTION

Sensing Input

- Terminal 0 ~ 110V = 95 ~ 135V
- Terminal 0 ~ 220V = 180 ~ 250V
- Terminal 0 ~ 380V = 360 ~ 515V
- Frequency 50/60 Hz, Jumper selectable

Harmonic Voltage

Voltage 25 ~ 300VAC

Voltage Regulation

< ±0.5% (with 4% engine governing)

Voltage Build-up

Harmonic Residual Volt. > 5 VAC

Output Voltage

Maximum 90VDC @220VAC

Output Current

- Maximum Continuous 8 A
- Intermittent 12 A for 10 sec

External Volts Adjustment

±10% @ 1KΩ

X1 · X2 Z1 · Z2

45 ~ 600HZ

Thermal Drift

0.05% per °C change in AVR ambient

Analog Voltage Input

10% generator voltage per 1VDC

Current Compensation

- N : 5 A or N : 1A Input
- Maximum 4% @ P.F. = 0.8

Dimensions

150mm L * 135mm W * 55.3mm H

Weight

600g ± 5%

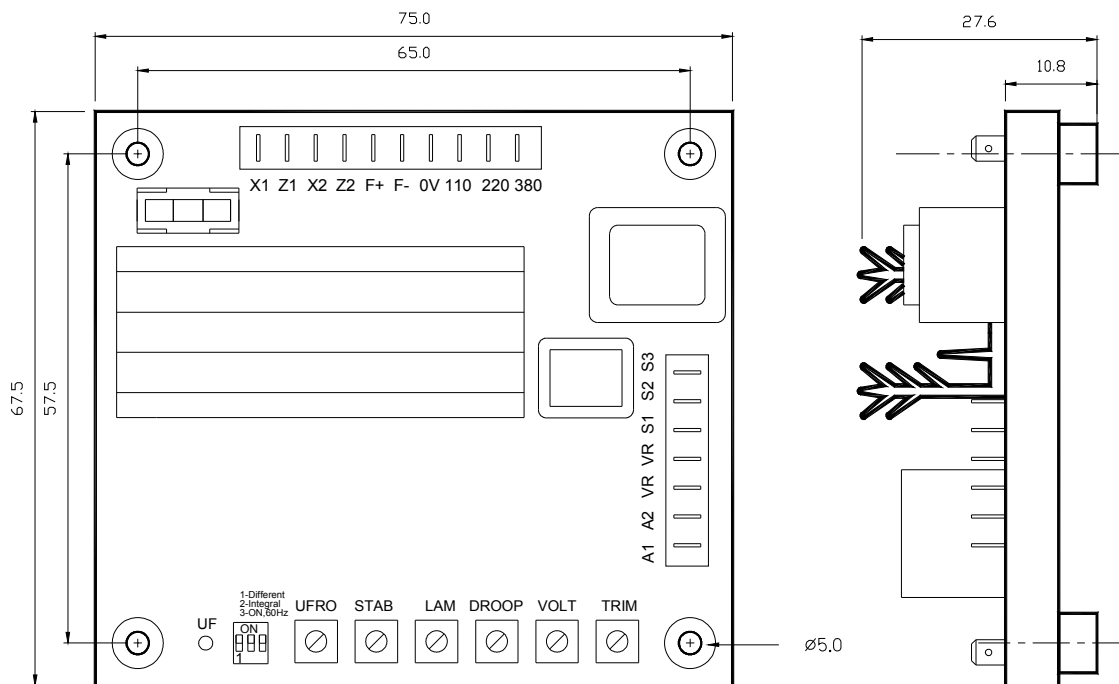

Figure 1 Outline Drawing

Mechanical Specifications

AVR can be mounted directly on the engine, genset, switchgear or control panel that conforms to the mounting specification.

All voltage readings are to be taken with an average-reading voltmeter Meggers and high-potential test equipment must not be used. Use of such equipment could damage the AVR.

2. WIRING

1. 0V-110-220-380 Sensing Input terminal.
2. F+ 、 F- : Excitation Output.
3. X1-X2 、 Z1-Z2 Power Input terminal. When using single phase power input, please connect to X1 - X2 or Z1 - Z2. For 3 phase power input, please connect to X1 、 Z1 、 Z2 terminals. The power input can be PMG, Harmonic, Full Harmonic and Auxiliary Winding.
4. S1-S2 : Current compensation input. Current Transformer secondary current = 1A.
5. VR-VR External Voltage Adjustment 1KΩ.
6. Analog Voltage Input Can accept remote DC voltage to adjust generator output voltage.

- TRIM : Analog Voltage Input Adjustment.

- VOLT : Voltage Adjustment.

- DROOP : Droop Adjustment.

- DIP : To set the frequency related voltage dip

- STAB : Stability Adjustment.

- UFRO : UFRO Knee Point set.

- DIP SWITCH : Function Selection Switch.

1. Voltage Compensation : ON => for over 550KW

2. Reaction Time Range: ON = > for 90 ~ 550KW

3. Rated Frequency 50/60Hz Selection :

ON = 60Hz

OFF = 50Hz

3. ADJUSTMENTS

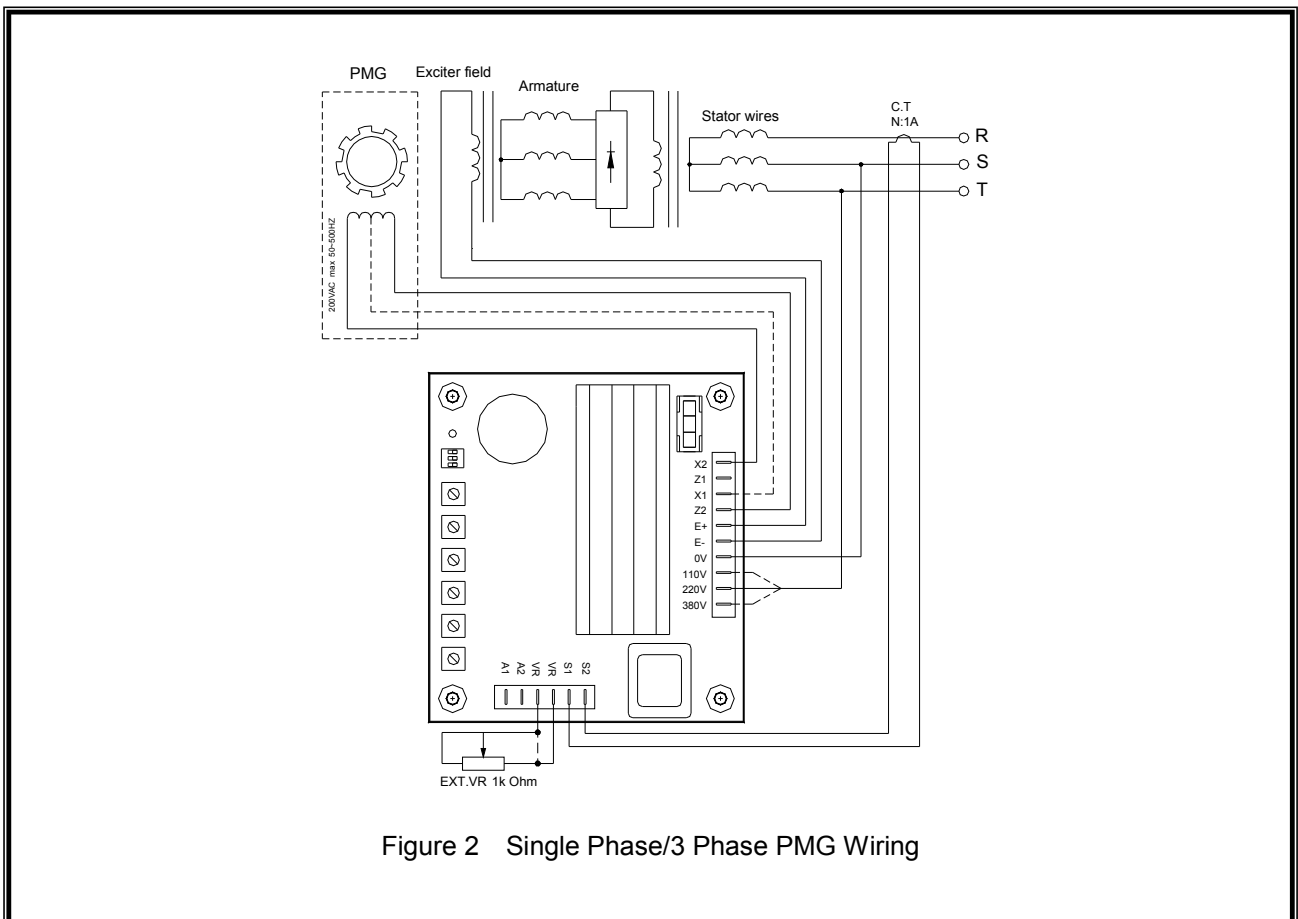

Figure 2 Single Phase/3 Phase PMG Wiring

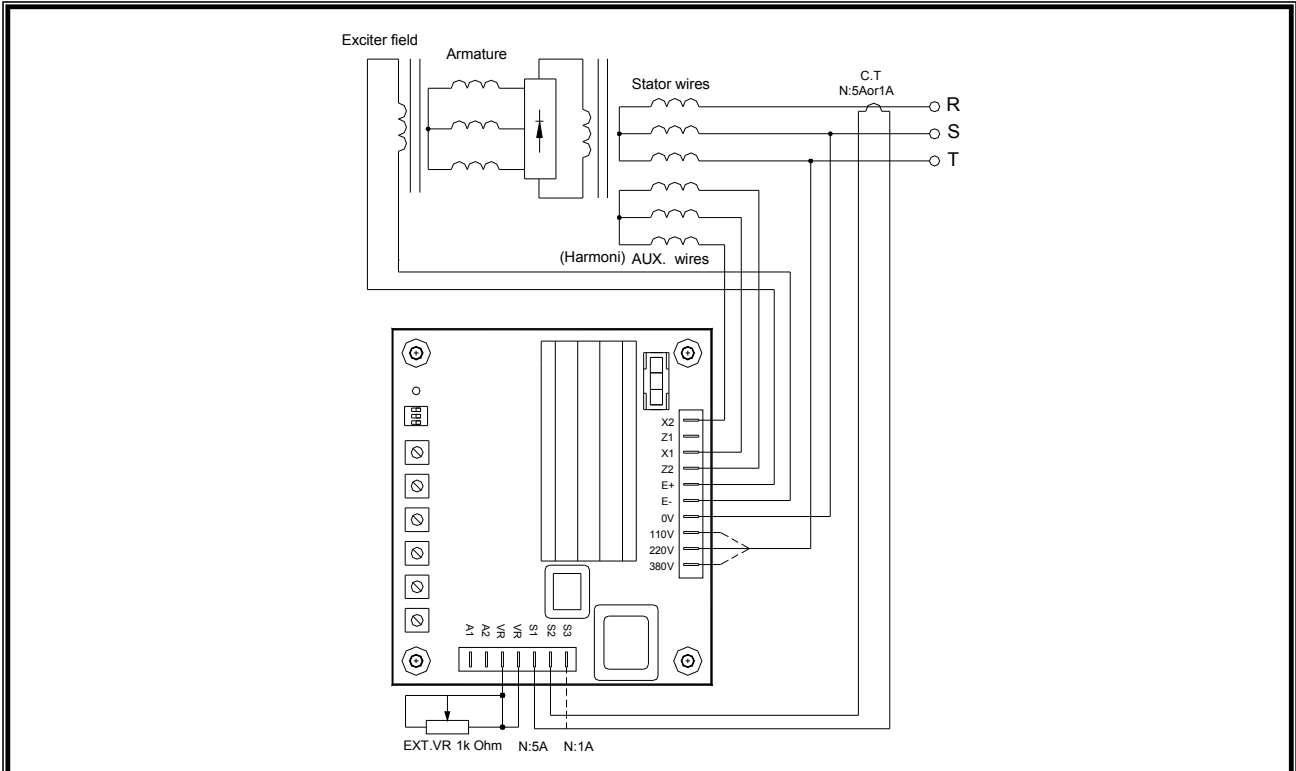

Figure 3 3 Phase (Auxiliary Winding, Full Harmonic, Self Excited) Wiring

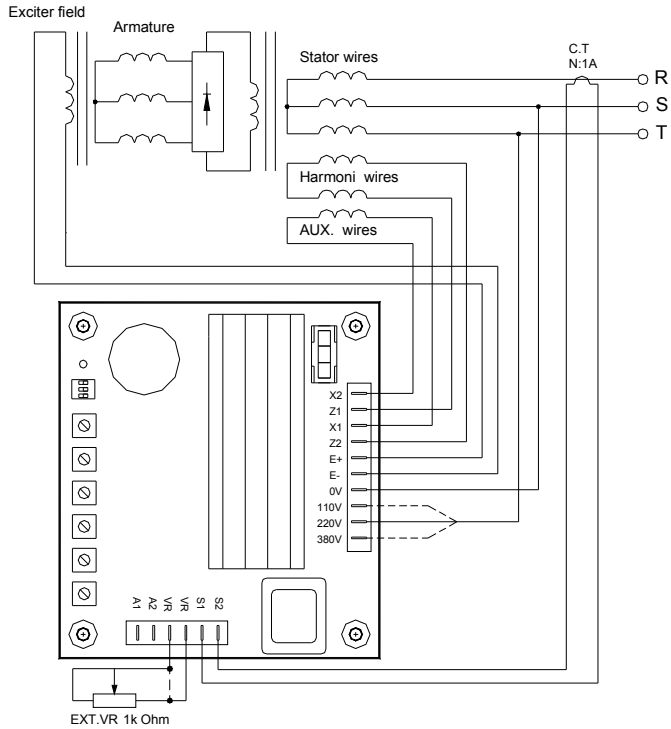

Figure 4 Auxiliary Winding & Harmonic Wiring

- ※ Please use original spare fuse (10A).
- ※ Product Performance, specification and appearance are subject to change (Improvement) without prior notification.