

RADIATOR AIR DISCHARGE

EXHAUST OUTLET

1 1/4" PIPE COUPLING FUEL INLET

1 1/4" PIPE COUPLING FOR DUAL FUEL ONLY

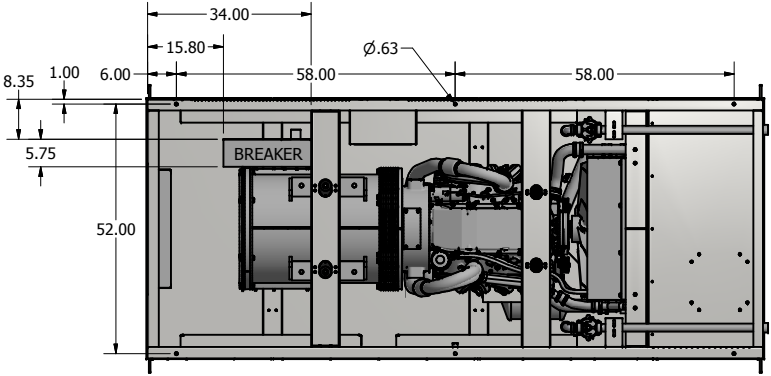

DRAWN	1/28/2013	TAYLOR POWER SYSTEMS	
CHECKED		TITLE	
QA		TG125 MODEL WITH 8.8L	
MFG		GENERAL MOTORS ENGINE	
APPROVED		SIZE	DWG NO
		C	TG125
		SCALE	SHEET 1 OF 1