

CUSTOMER APPROVAL SIGNATURE	APPROVAL DATE	COMMENTS
INCLUDED FEATURES	PART #	WEIGHT
ENGINE: General Motors S7L V-8 (Roader for through flywheel)	VA39001016	600 Lbs.
ALTERNATOR: MARATHON 361CSL1601	361CSL1601	620 Lbs.
SUB-BASE: STRUCTURAL STEEL NARROW	BOLT TOGETHER	176 Lbs.
ISOLATORS: (2) LF15570 (2) LF26502		12 Lbs.
OIL DRAIN EXTENSION: WITH VALVE ROUTED TO SKID	V11204N	MISC.
(1) BATTERIES: GROUP 31 STYLE 12V BATTERY RACK AND CABLES FOR BATTERY Note: Rack is integral to the skid	V13P6	41 Lbs.
CONTROL PANEL		MISC.
CIRCUIT BREAKER: ABB		MISC.
ABB ENCLOSURE		MISC.
WEIGHT SUBTOTAL		1,449 Lbs.
MISC. WEIGHT: 5% of subtotal		72 Lbs.
TOTAL WEIGHT:		1,521 Lbs.

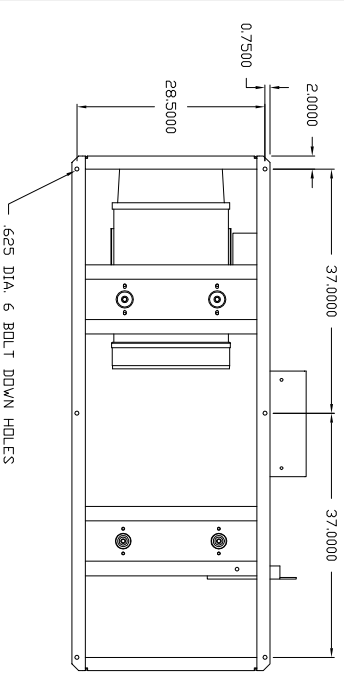
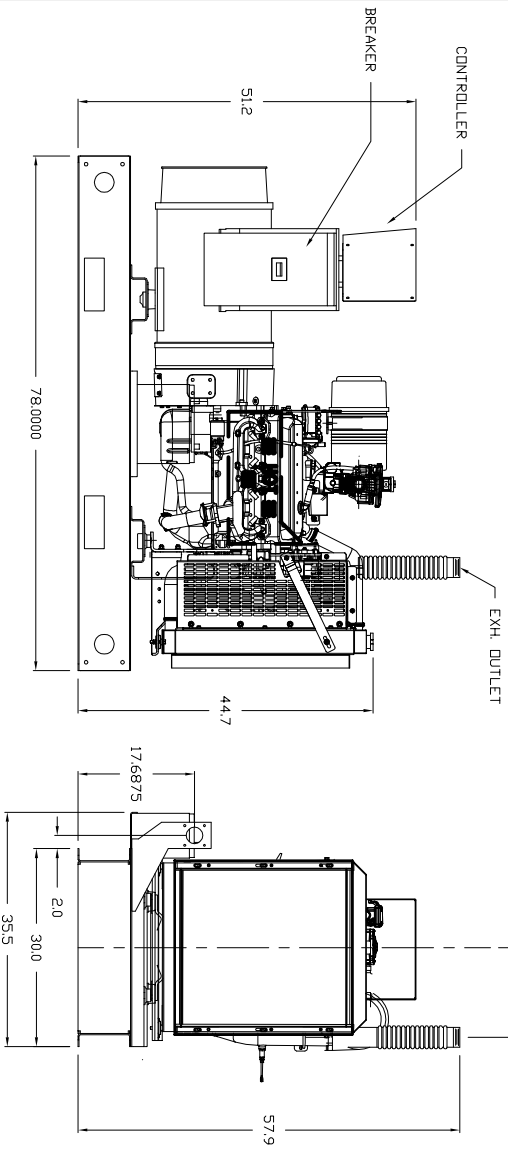
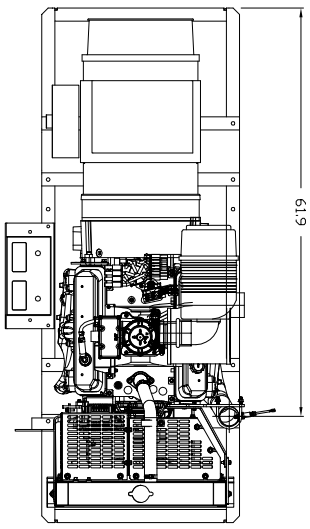

DRAWN JOHN	9/30/2011	TITLE TAYLOR POWER SYSTEMS	
CHECKED			
QA		TG60 OPEN UNIT NARROW SKID	
MFG			
APPROVED		SIZE C	DWG NO. TG60 NARROW SKID
		SCALE	REV