

CUSTOMER APPROVAL SIGNATURE	APPROVAL DATE	COMMENTS
INCLUDED FEATURES	PART #	WEIGHT
ENGINE: DODSON AND (order or through flywheel)	0111L	2695 Lbs. WET
ALTERNATOR: MARATHON	431C3L6206	1415 Lbs.
SUB-BASE: STRUCTURAL STEEL		1092 Lbs.
SIDE-IN TOP-OUT VERTICAL MOUNT SILENCER	V162304	80 Lbs.
STANDARD ENCLOSURE		1743 Lbs.
SKID EXTENSION		177 Lbs.
ISOLATORS (4) LF21000	V1LF21000	12 Lbs.
FUEL SYSTEM		MISC.
OIL DRAIN EXTENSION WITH VALVE ROUTED TO SKID		MISC.
(2) BATTERIES 80 GAL SYSTEM	V18D	150 Lbs.
BACK AND CABLES FOR BATTERY		
Note: Rack is integral to the skid		
CONTROL PANEL		MISC.
CIRCUIT BREAKER: ABB		MISC.
ABB ENCLOSURE		MISC.
WEIGHT SUBTOTAL		7,364 Lbs.
MISC. WEIGHT: 5% of subtotal		368 Lbs.
TOTAL WEIGHT:		7,732 Lbs.

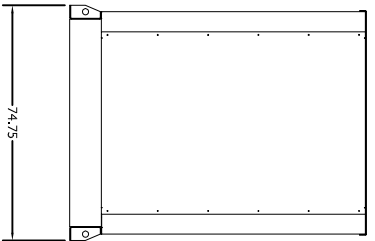
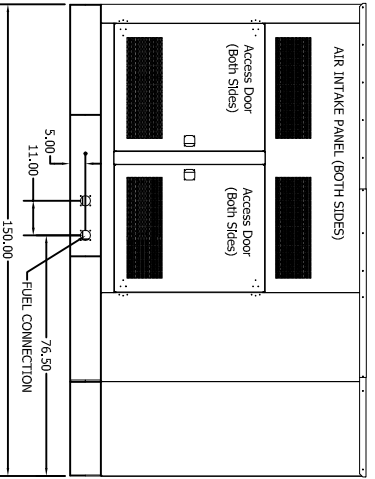
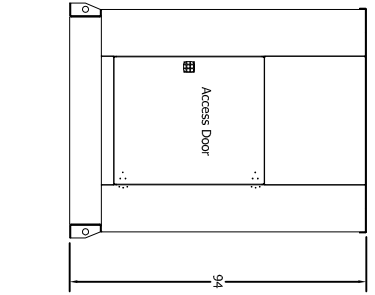
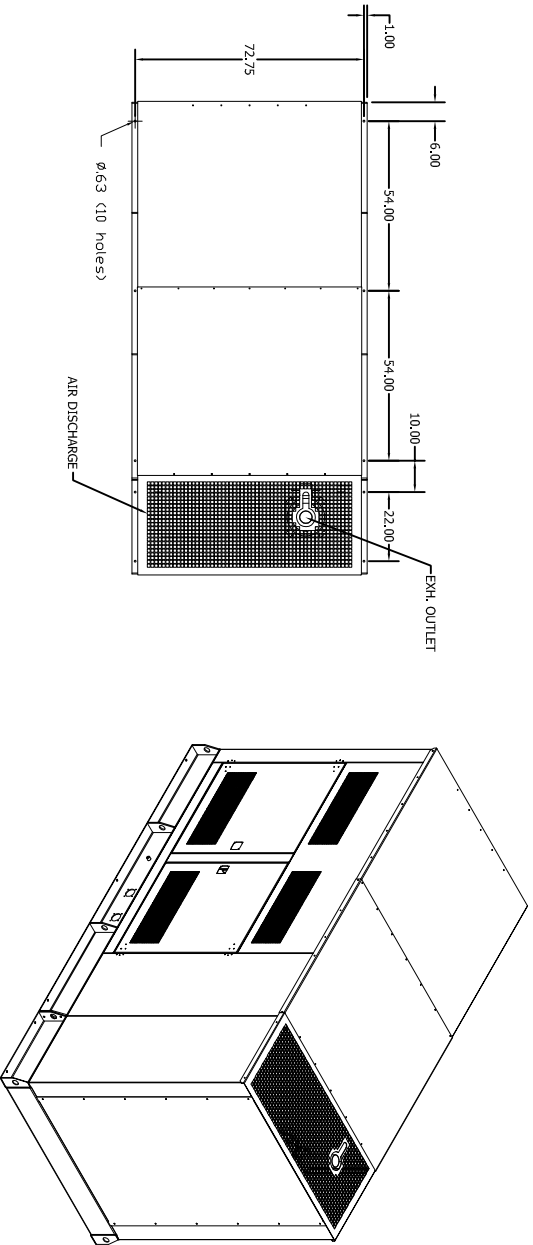

DRAWN	6/13/2011	TITLE	TAYLOR POWER SYSTEMS
JOHN		SIZE	C
CHECKED		DWG. NO.	TG200 ENC
QA		REV	
APPROVED		SCALE	SHEET 1 OF 1
		TG200 STANDARD ENCLOSURE	