

NEWAGE J BOX NRTT GENERATOR CONTROL MANUAL

GENERAL DESCRIPTION

The NUB1P-3P Generator Control System is a micro processor based, digital read out control system consisting of:

ENGINE CONTROL BOARD

The Engine Control Board houses the Engine Control Relays, Engine Interconnect Terminals, Speed Sensing, Power Supply, and Signal Conditioning. The NUB1P-3P is available with Magnetic Pickup speed sensing. The Engine Control Relays are rated at 10 Amps. The plug harness connection is rated at 10 amps.

AC MONITORING BOARD

The AC Monitoring Board senses the AC Voltage and AC Current through its respective plugs. The AC Monitoring Board is internally connected to the Engine Control Board.

The NUB1P-3P Control System is available for diesel, natural gas, LP, and gasoline engines with either 12 or 24 VDC battery. The engine vital: Oil Pressure, Engine Temperature, Battery Voltage, and Safeties are monitored on the large two line Super Twist, extended temperature, Back-Lighted LCD display. Automotive type senders are provided with the control system. Generator AC Voltage, AC Amperage, and Frequency are also displayed on the LCD display. Current transformers are provided with the Generator Control System.

Oil Pressure, Engine Temperature, and Battery Voltage are displayed continuously. The AC Volts and AC Amps are scrolled between each phase along with frequency. The Running Time is displayed every 60 seconds.

The NUB1P-3P is mounted with vibration isolated on a J box mounting plate with Oil Pressure Sender, Engine Temperature Sender, Current Transformers, and mating plug harness is included for ease of maintenance.

INSTALLATION INSTRUCTIONS

NOTE: BEFORE INSTALLATION MAKE CERTAIN THAT THE ENGINE BATTERY IS DISCONNECTED AND THAT THE ENGINE SELECTOR TOGGLE IS IN THE OFF POSITION

TOOLS REQUIRED

Drills punch, 16 AWG wire, wire fittings, cutters, crimpers, screw driver, and nut drivers.

1. Install Oil Pressure Sender in engine block.
2. Install Engine Temperature Sender in engine block.
3. Install Magnetic Pickup in fly wheel housing.
4. Install Current Transformers. (must physically be aligned in the same manner)
5. Connect wire harnesses and connections to toggle switch per schematic.
6. After checking that the Engine Selector is in the OFF position, connect the Battery Positive (+) and Negative (-) per schematic.

NOTE:
THE NEWAGE J BOX CONTROL SYSTEM IS DESIGNED TO OPERATE ON A GROUNDED "Y" CONNECTED GENERATOR. FAILING TO GROUND THE NEUTRAL WILL CAUSE DAMAGE TO THE CONTROL SYSTEM.

ENGINE SEQUENCE OF OPERATION

- A. With the Selector Toggle in OFF no display or power draw.

SELECTOR SWITCH IN RUN POSITION

Placing the Selector Switch in the RUN mode will initiate the start sequence:

- A. The engine Start Contact will close battery positive (+) to the Cranking Motor Slave Relay. There should be a suppression DIODE connected across the Slave Relay. (See technical notes.)
- B. The Engine Fuel Contact will close battery positive (+) to the Fuel system. There should be a suppression DIODE connected across the Fuel system coil. (See technical notes.)
- C. The LCD display will display STARTING ENGINE during cranking.
- D. When Crank Termination is reached the Start Contact will open, disengage the Cranking Motor Slave Relay and lock out the starting circuit until the system is Reset. There are 5 cranking cycles of 10 seconds on and 10 seconds rest between cranks. If the engine does not start after the fifth crank, the Crank Contact and the Fuel Contact will be opened and locked out. The LCD display will read **FAULT OVER CRANK**. Manual reset by placing the toggle switch in the OFF position is required before another cranking cycle can be initiated or removing the Remote Start signal will cause a reset.

- E. Upon Crank Termination the NUB1P-3P checks for false crank termination. The **START CHECK** feature monitors the engine speed immediately after crank termination. If the engine speed goes below crank termination speed, during the first 10 seconds of run, the Fuel Contact is opened, and engine speed is monitored while the engine coasts to rest, preventing the cranking motor from energizing if the engine is not at **ZERO SPEED**, a **RESTART SEQUENCE** is initiated, after the engine speed equals zero.

- F. After **START** the NUB1P-3P enters an Oil Pressure bypass time delay, followed by display engine and generator information.

- G. The Oil Pressure, Water Temperature, Frequency and Battery Voltage are displayed while the AC volts and amperage values are scrolled. Running Time is displayed every 60.0 seconds.

- H. Should a Fault such as Low Oil Pressure, High Engine Temperature, Overspeed, or Overcrank occur, the Fuel Contact will be opened and locked out. The LCD display will display the Fault Condition. Manual Reset is required before a Restart can be initiated.

SELECTOR IN THE AUTO POSITION

Placing the selector in the Auto position:

- A. No display and no power draw.
- B. Closing the Remote Start Contact will place the NUB1P-3P in the **RUN SEQUENCE** as described above. Removing the Remote Start signal will stop the Generator placing the NUB1P-3P back into the Automatic mode awaiting another Remote Start signal.
- C. If any faults occur in Auto, a manual reset or removing the remote start signal is required before a restart can be initiated.

FAULT TEST PROCEDURE

OVERCRANK

Disconnect the Fuel system. Place toggle switch in RUN position. The engine will crank 5 times with 10 seconds cranking efforts with 10 seconds rest. The Crank Relay and Fuel Relay will lock out, and the LCD display will read FAULT OVERCRANK. Manual reset is required before restart can be initiated. (It is recommended that the cranking motor also be disconnected while doing the test to preserve cranking battery charge).

OVERSPEED

Place the Engine selector in the RUN position, allowing the engine to run. Manually increase the fuel until OVERSPEED speed is achieved. The Fuel Contact will open and lock out, and the LCD will display FAULT OVERSPEED. Manual reset is required before another start can be initiated.

HIGH TEMP

Place the Engine Selector in the RUN position allowing the engine to run. Manually ground the Engine Temperature Sender to the engine block. The Fuel Contact will open and lock out, the Fault Relay will close, and the LCD will display FAULT HIGH ENGINE TEMPERATURE. Manual reset is required before a restart can be initiated. There is a 5 second delay on this fault.

LOW OIL PRES

Place the Engine Selector in the RUN position allowing the engine to run. Manually remove the Oil Pressure Sender wire. The Fuel Contact will lock out, and the LCD will display FAULT LOW OIL PRESSURE. Manual reset is required before a restart can be initiated. There is a 5 second delay on this fault.

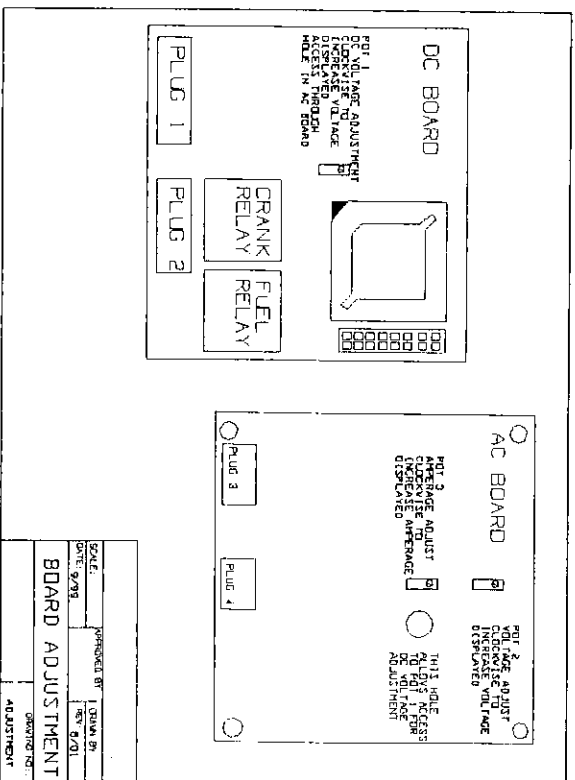

- AC Voltage Adjustment
- AC Amperage Adjustment
- DC Voltage Adjustment

TECHNICAL NOTE 17 Frequency Adjustment

SPEED SET PROGRAM (optional) Push button through face plate

A small push button has been installed at the top of the engine board. The push button is located directly behind the 1/4" hole in the face plate.

Start and allow the engine to come up to 1900 RPM, measured with a frequency meter or hand held tachometer.

When the engine is at 1900 RPM – Using the wooden dowel depress the push button. The speed should be set to 60.0 Hz or 1800 RPM on power units. Double check the LCD readings with your manual reading. If they agree place the 1/4" plug in the hole in the face plate.

If the reading is not correct repeat the procedure.

TECHNICAL BULLETIN #3

OIL PRESSURE SENDERS

The typical automotive oil pressure sender utilizes the engine block as a ground reference. The pressure change is measured through a small restricting orifice to a diaphragm which moves a wiper across a resistor. The resistor may be Thick Film, Ceramic or Wire Wound. The typical resistance change, using a Stewart Warner curve for 0 - 100 lb. is 230-240 ohms equal 0 pounds and 29-33 ohms equal 100 pounds pressure.

Oil pressure readings may vary slightly from sender to sender. Pressure readings from gauge to gauge will also vary, slightly depending upon the specific gauge. Pressure readings will also vary if the readings are taken from different ports on the engine. As the wiper moves across the resistor, the reading may vary depending on the arm sweep and which segment of the resistor the arm is resting on.

Some engines may have enough vibration to cause a sender to fail prematurely. The wiper may wear a specific portion of the resistor, or cause the wiper to bounce on the resistor. If this occurs the pressure will read lower than actual. If a total failure occurs, it will be to 0 pounds pressure. In some applications a rubber or nylon hose may be required to dissipate the vibration. In some prime power applications the oil pressure sender may fail due to dirt buildup caused by constant speed or the engine not allowing the wiper to clean itself across the resistor by starting and stopping.

If the engine has a harmonic vibration that caused the oil pressure sender to fail frequently or precise oil pressure measurement is desired, a Strain Gauge can be considered for these specific applications. The Strain Gauge is relatively expensive, but the accuracy and long life in these applications are well worth the expense. Strain Gauges are available from Controls Inc.

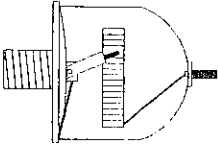

NOTE: 1

THE CONTROL YOU HAVE PURCHASED IS A HIGH QUALITY ELECTRONIC INSTRUMENT. THE HEART OF WHICH IS DESIGNED TO RUN ON 5 VOLTS DC. THE MOST COMMON INSTALLATION PROBLEMS THAT OUR CUSTOMERS HAVE RELATED TO EITHER LACK OF OR A POOR GROUND AND ELECTRONIC NOISE FROM SPARK IGNITED ENGINES. WHEN ANY ELECTRONIC CONTROLS ARE USED THE MOST IMPORTANT CONNECTION IS THE GROUND. THE BEST GROUND IS DIRECTLY TO THE NEGATIVE BATTERY POST. IT IS ALSO IMPORTANT TO CONNECT THE POSITIVE CONNECTION AS CLOSE TO THE POSITIVE BATTERY POST AS POSSIBLE TO AVOID VOLTAGE DROPS AND PROVIDE THE BEST POWER TO THE CONTROLS AS POSSIBLE.

IF YOU HAVE EXPERIENCED ANY PROBLEM WITH THE INSTALLATION FEEL FREE TO CALL OUR ENGINEERING STAFF, AT (330) 239-4345, BUT FIRST CHECK THE FOLLOWING:

1. Make sure that the neutral is bonded to ground when you load bank the unit. Failure to do this may result in erroneous read outs to the control. When the generator is shipped into the field your customer may ground the neutral differently than you did, as long as they follow the NEC there will not be a problem.
2. If the control faults out at crank termination (when the engine starts) the suppression diode may not be installed on the cranking motor relay. If the diode is not installed on the cranking motor solenoid and the fuel relay large negative voltage spikes approaching 300 volts may be generated. These voltage spikes can cause either a glitch or damage to electronic controls, including electronic governors.
3. On spark ignited engines ignition noise is especially high. Make certain that none of the wires to the electronic control are touching the spark plug wires. Air is the best insulator. The high voltage noise from spark ignited engines can cause the microprocessor to crash. With proper installation the noise problem can be eliminated.
4. Our control system requires 2 battery positive connections. This is done to prevent voltage drop to the microprocessor during cranking. Remember that the battery positive connection should be as close to the battery post as possible. If one battery connection is used to feed both battery positives on the control engine board make certain that the conductor is large enough to prevent voltage drop caused by current draw and inrush.
5. Please review all of the manuals, technical notes, and schematics. If you have done so and still are experiencing problems please check our web site for additional technical information www.controlsinc.com or call us at 330-239-4345 for assistance.

We at Controls Inc. strive to manufacture leading edge technology based control systems. Our control systems are manufactured and tested under the strictest quality control procedures available to us. Our products are designed specifically for the industrial environment that engines and generators are used for. When properly applied and installed Controls Inc. products will provide years of reliable service.

UNITED WARRANTY

CONTROLS, INC. is herein called "Seller". The person, firm or corporation to whom or which the sale is made is herein called "Buyer".

Seller warrants to the Buyer that all products furnished under this order will conform to Seller's specification, drawings as described in its current catalog or quotation and will be free from defects in materials and workmanship. Other special requirements asked for by the Buyer in its purchase order must be approved in writing by Seller. Parts replaced or repaired in the warranty period shall carry the unexpired portion of the original warranty. The foregoing is subject to the provisions that in no case will the total warranty period extend beyond twelve (12) months from date seller ships equipment from point of sale.

The Liability of Seller hereunder is limited to replacing or repairing at Seller's factory or on job site at Seller's option, any part or parts which have been returned to the Seller and which are proved by buyer as defective or not conforming to Seller's specifications, drawings or other written descriptions, accepted by Seller, provided that such part or parts are returned by the buyer within thirty (30) days after such defect is discovered. The Seller shall have the sole right to determine if the parts are to be repaired at the job site or whether they are to be returned to the factory for repair or replacement. All items returned to Seller for repair or replacement must be sent freight prepaid to its factory. Buyer must obtain Seller's Return Goods Authorization prior to returning items. The above conditions must be met if warranty is valid. Seller will not be liable for any damage done by unauthorized repair work, unauthorized misapplication in non suitable environment.

In no event shall the Seller be liable for loss, damage, or expense directly or indirectly arising from the use of the units, or from any other cause, except as expressly stated in the warranty. Seller makes no warranties, express or implied, including any warranty as to merchantability of fitness for a particular purpose or use. Seller is not liable for and buyer waives any right or action it has or may have against seller for any consequential or special damages arising out of any breach of warranty, and for any damages buyer may claim for damage to any property or injury or death to any person arising out of its purchase or the use, operation or maintenance of the product. Seller will not be liable for any labor subcontracted or performed by buyer for preparation of warranted item for return to Seller's factory, or for preparation work for field repair or replacement. Invoicing of Seller for labor either performed or subcontracted by buyer will not be considered as a liability by the Seller.

This warranty shall be exclusive of any and all other warranties express or implied and may be modified only by a writing signed by an officer of the Seller. With respect to accessories supplied by Seller, but manufactured by others, there is no warranty of any kind, express or implied, and specifically there is no warranty of merchantability or fitness, except as may be set forth in any warranty the manufacturer have made to Seller and which can be passed to the Buyer.

Buyer has not relied and shall not rely on any oral representation regarding the products sold hereunder and any oral representation shall not bind seller and shall not be part of warranty.

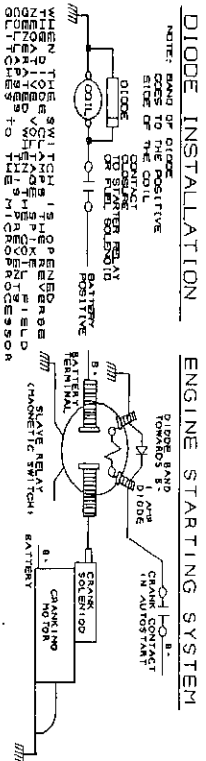
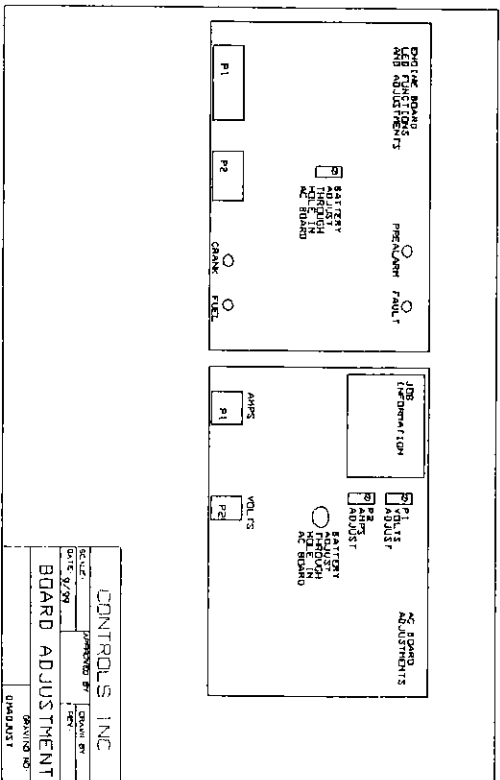

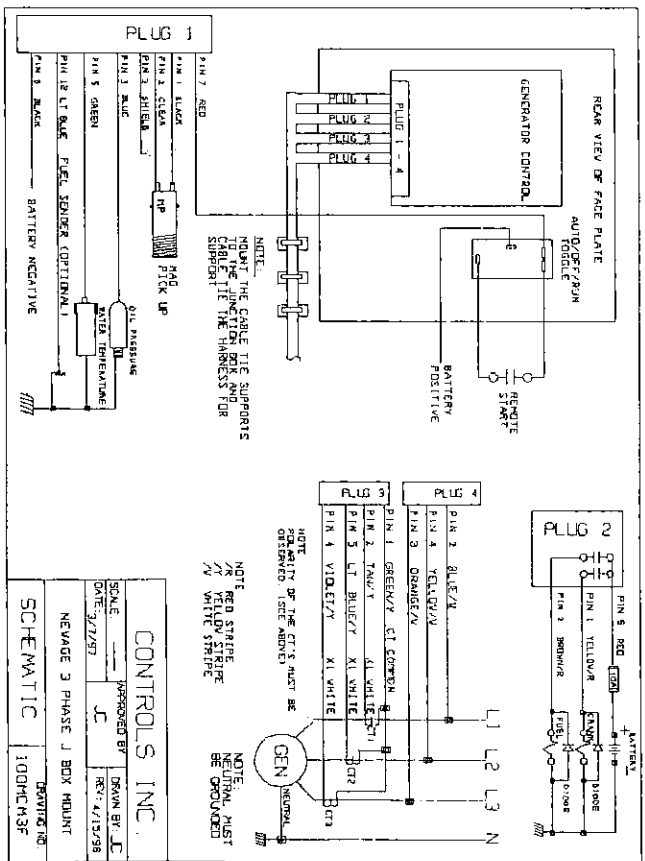
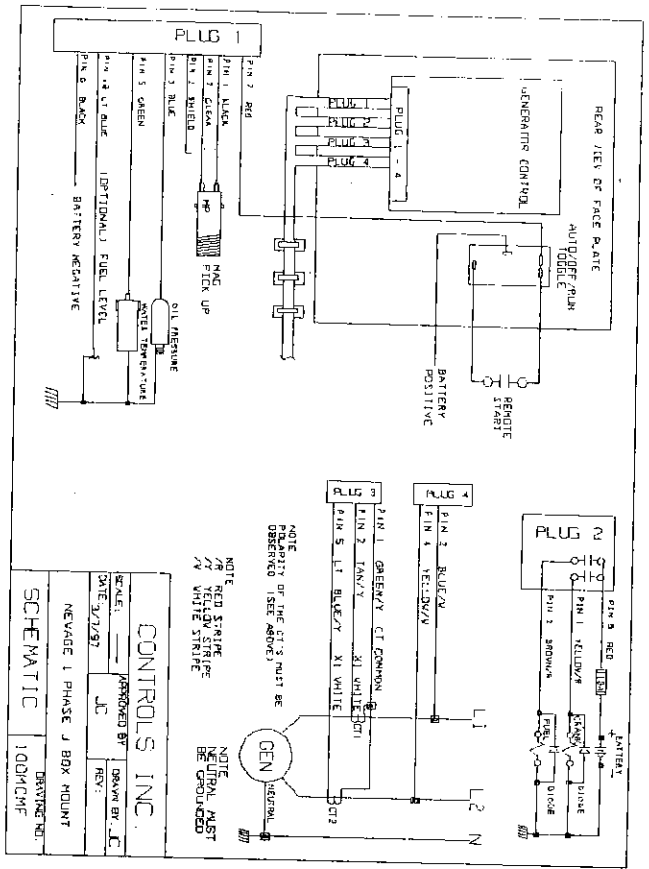

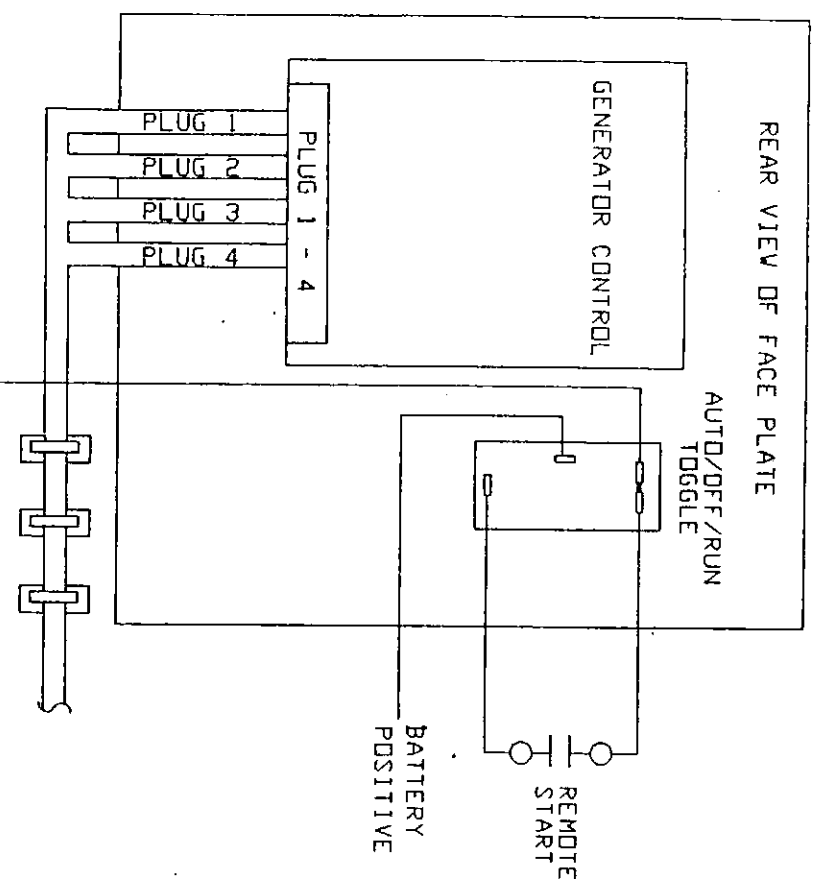
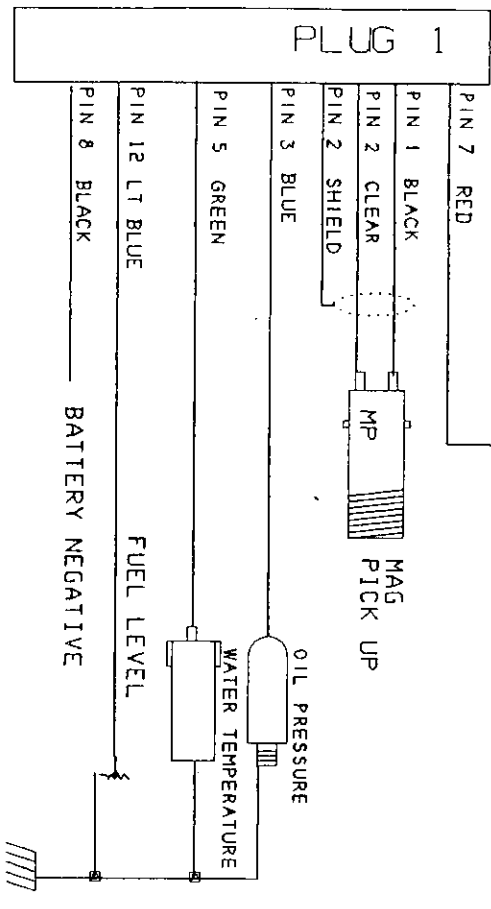

NOTE:
POLARITY OF THE CT'S MUST BE OBSERVED. (SEE ABOVE)

NOTE:
RED STRIPE /R
YELLOW STRIPE /Y
WHITE STRIPE /W

NOTE:
NEUTRAL MUST BE GROUNDED

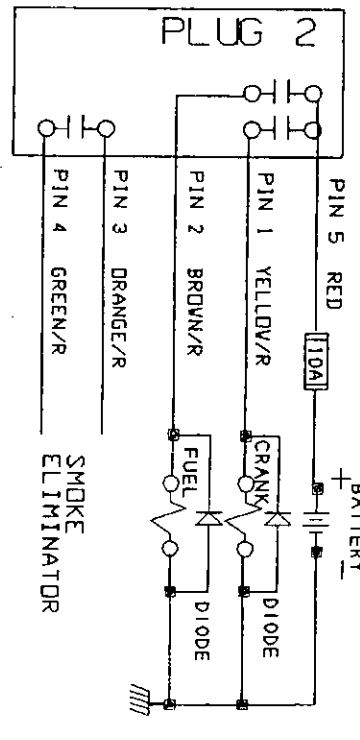
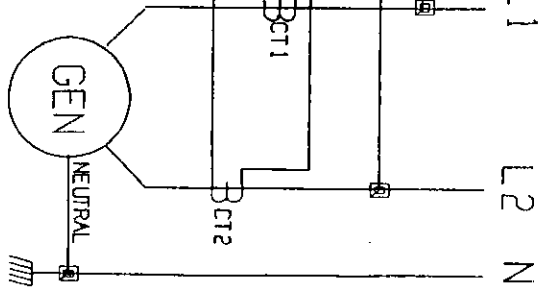

CONTROLS INC.

SCALE: _____ APPROVED BY: JC

DATE: 3/7/97 REV: _____

NEVAGE 1 PHASE J BDX MOUNT

SCHEMATIC

DRAWING NO: 100MCMF