

CUSTOMER APPROVAL SIGNATURE	APPROVAL DATE	COMMENTS	
INCLUDED FEATURES		PART #	WEIGHT
ENGINE: PERKINS 1106D-E66TAG3 (radiator through flywheel)		VAPJ38418	1,654 Lbs.
ALTERNATOR: MARATHON		43ICSL6202	1220 Lbs.
SUB-BASE: STRUCTURAL STEEL NARROW		BOLT TOGETHER	200 Lbs.
ISOLATORS: (4) 4960060		VT4960060	12 Lbs.
BLOCK HEATER: 1500 WATT / 120 VOLT		VTTPS151GT1	MISC.
FLEX FUEL LINES		VTGRU03202	MISC.
CABLE AND WIRING		N/A	MISC.
HARDWARE (BOLTS & WASHERS)		N/A	MISC.
(1) BATTERIES: GROUP 31 STYLE 12V BATTERY RACK AND CABLES FOR BATTERY Note: Rack is integral to the skid		VT31P6	41 Lbs.
CONTROL PANEL: Digital Auto Start			MISC.
CIRCUIT BREAKER: ABB			MISC.
WEIGHT SUBTOTAL			3,127 Lbs.
MISC. WEIGHT: 5% of subtotal			156 Lbs.
TOTAL WEIGHT OPEN UNIT:			3,283 Lbs.

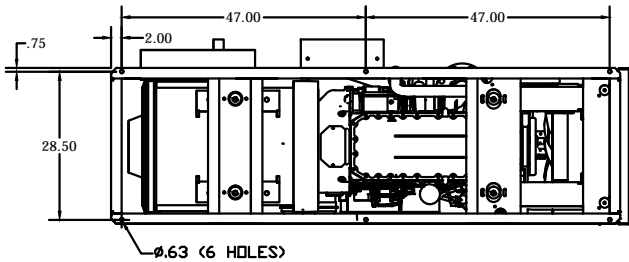
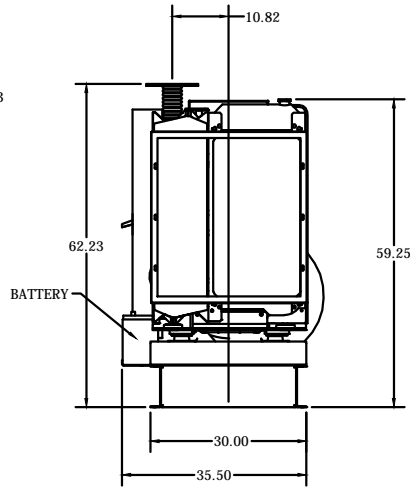
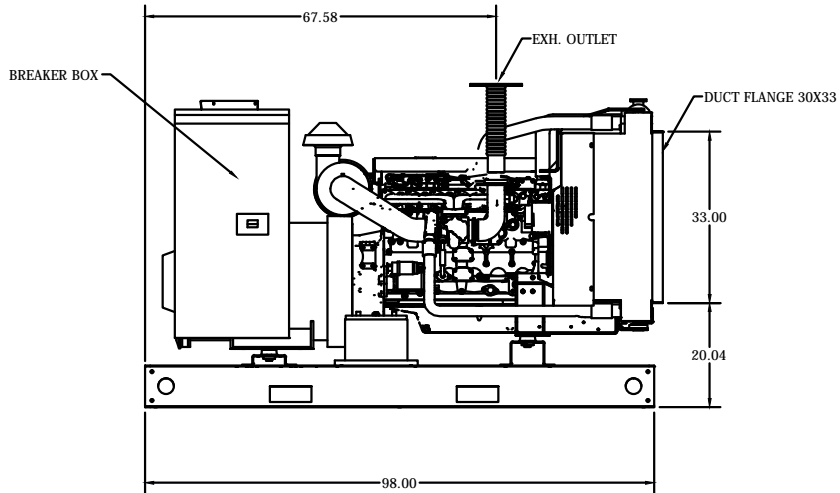

DRAWN John	6/15/2011	TAYLOR POWER SYSTEMS	
CHECKED		TITLE	
QA		TD150 OPEN UNIT WITH NARROW SKID	
MFG		SIZE	DWG NO
APPROVED		C	TD150 OPEN UNIT
		SCALE	REV
			SHEET 1 OF 1