

CUSTOMER APPROVAL SIGNATURE	APPROVAL DATE	COMMENTS	
INCLUDED FEATURES		PART #	WEIGHT
ENGINE: PERKINS 2206D-E13TAG3 Electropak (radiator through flywheel)		VAE13TAG3	3,252 Lbs.
ALTERNATOR: MARATHON 433CSL6220		433CSL6220	2,245 Lbs.
SUB-BASE: STRUCTURAL STEEL		VT087522	779 Lbs.
ISOLATORS: (2) LF31200 (2) LF42100		VTLF31200 VTLF42100	12 Lbs. 15 Lbs.
BLOCK HEATER 4000W 240V		VTCL1402102	MISC.
FLEX FUEL LINES:		VTGRU03218	MISC.
WIRE AND CABLE			MISC.
FLUIDS			MISC.
STAINLESS HARDWARE (BOLTS, HINGES, ETC.)			MISC.
(2) BATTERIES: 8D STYLE RACK AND CABLES FOR (2) BATTERIES Note: Rack is integral to the skid		VT8D	150 Lbs.
CONTROL PANEL: Digital Auto Start DGC2020			MISC.
CIRCUIT BREAKER: ABB			MISC.
WEIGHT SUBTOTAL			6,453 Lbs.
MISC. WEIGHT: 5% of subtotal			323 Lbs.
TOTAL WEIGHT:			6,776 Lbs.

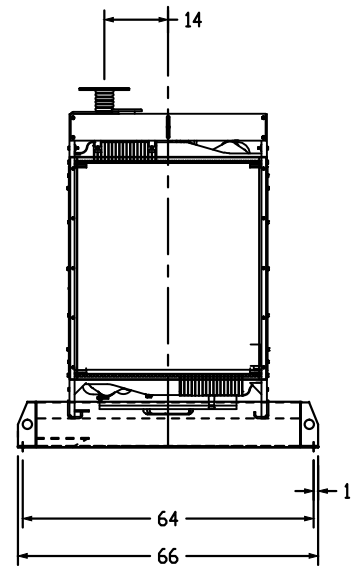
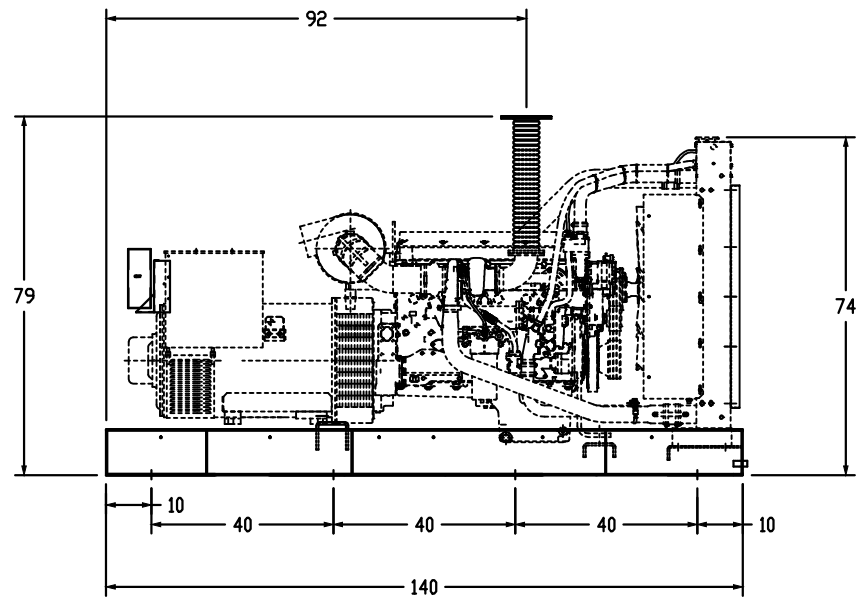
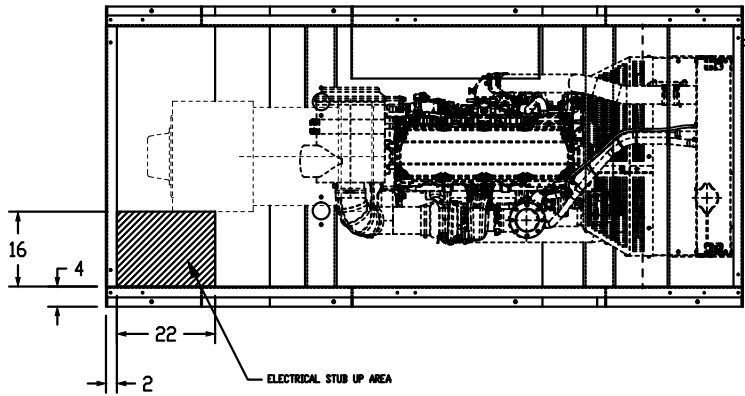

DRAWN John	6/15/2011	TAYLOR POWER SYSTEMS	
CHECKED		TITLE	
QA		TD400 OPEN UNIT	
MFG			
APPROVED			
SIZE C	DWG NO TD400 OPEN UNIT	REV	
SCALE			SHEET 1 OF 1