

CUSTOMER APPROVAL SIGNATURE	APPROVAL DATE	COMMENTS
INCLUDED FEATURES		PART #
ENGINE: PERKINS 2506D-E15TAG3 Electropak (radiator through flywheel)		VAE15TAG3
ALTERNATOR: Marathon		572RSL4029
SUB-BASE: STRUCTURAL STEEL		VT087586
ISOLATORS: (2) LF31200 (2) LF42800		VTLF31200 VTLF42800
FLEX FUEL LINES:		VTGRU03218
WIRE AND CABLE		MISC.
FLUIDS		MISC.
STAINLESS HARDWARE (BOLTS, HINGES, ETC.)		MISC.
(2) BATTERIES: 8D STYLE RACK AND CABLES FOR (2) BATTERIES Note: Rack is integral to the skid		VT8D
CONTROL PANEL: Digital Auto Start DGCC020		MISC.
WEIGHT SUBTOTAL		7,829 Lbs.
MISC. WEIGHT: 5% of subtotal		391 Lbs.
TOTAL WEIGHT:		8,220 Lbs.

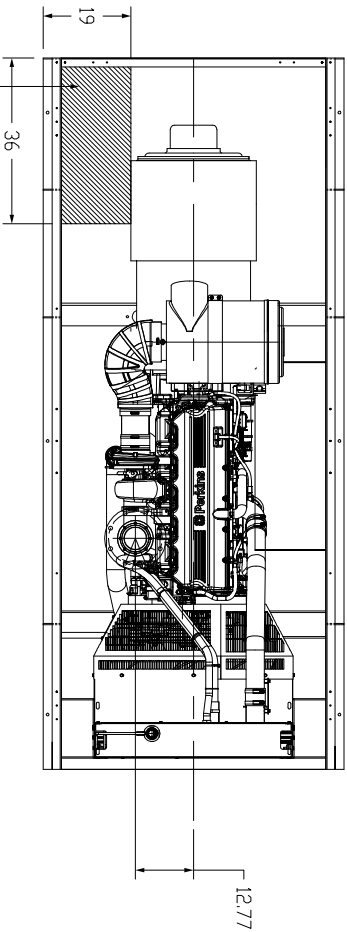

ELECTRICAL STUB UP AREA

DUCT FLANGE 45.75" X 43.375"

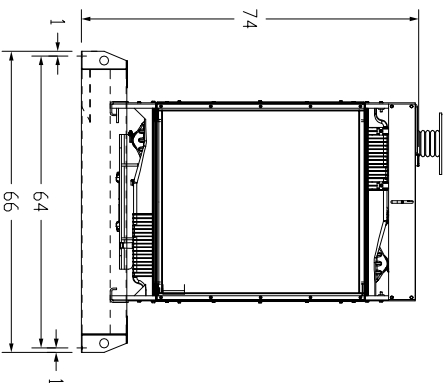
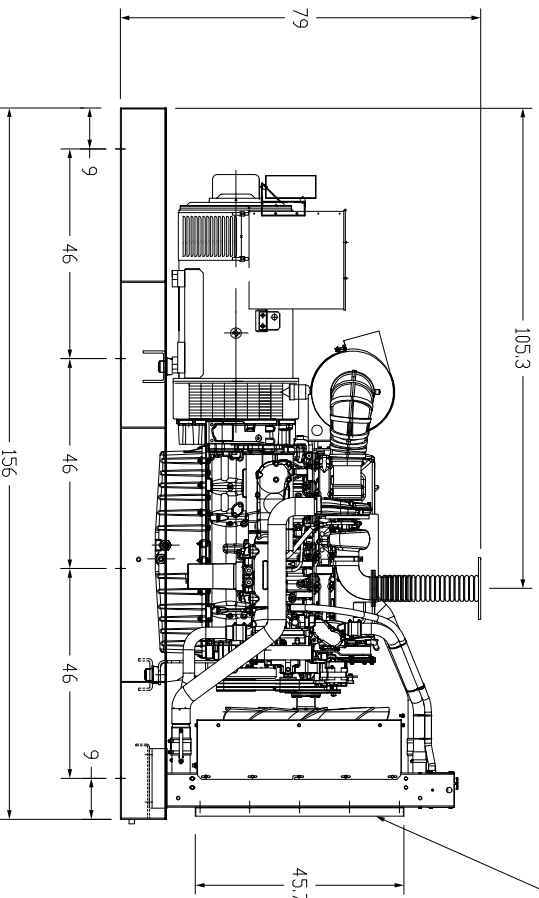

DRAWN		6/15/2011		TAYLOR POWER SYSTEMS	
CHECKED				TITLE	
QA				TD500 OPEN UNIT	
DESIGNED				SIZE	
APPROVED		C		DRAWING NO.	
		TD500 OPEN UNIT		REV	
		SCALE		SHEET 1 OF 1	