

CUSTOMER APPROVAL SIGNATURE	APPROVAL DATE	COMMENTS
INCLUDED FEATURES		PART #
ENGINE PERKINS 403D-15G (operator through flywheel)	GR65596	435 Lbs.
ALTERNATOR MARATHON 282CS1504	282CS1504	230 Lbs.
SUB-BASE STRUCTURAL STEEL	V1087375	126 Lbs.
ISOLATORS (4) Barry Controls 256416	V1256416	4 Lbs.
ENCLOSURE: CLAY POWDER COAT, 14 GA STEEL SOUND ATTENUATED ENCLOSURE	V16908459	465 Lbs.
FUEL TANK: U142 80 GALLON DOUBLE WALL	V1244078	510 Lbs.
SILENCER: SIDE-IN TOP-OUT VERTICAL MOUNT INTERNALLY MOUNTED	V162202	19 Lbs.
(1) BATTERIES: GROUP 26 STYLE 12V BATTERY RACK AND CABLES FOR BATTERY Note: Rack is integral to the skid	V161026	30 Lbs.
CIRCUIT BREAKER: AMP 400 ABB ENCLOSURE	MISC.	MISC.
FUEL LINES/FITTINGS	V16900325	MISC.
FLUID DRAIN EXTENSION WITH VALVE ROUTED TO SKID	V17108N	MISC.
CONTROL PANEL	MISC.	MISC.
HARDWARE: BOLTS, NUTS, WASHERS, LATCHES	MISC.	MISC.
FLUIDS: OIL & ANTIFREZE	MISC.	MISC.
WEIGHT SUBTOTAL		1,839 Lbs.
MISC. WEIGHT 5% of subtotal		92 Lbs.
TOTAL WEIGHT:		1,931 Lbs.

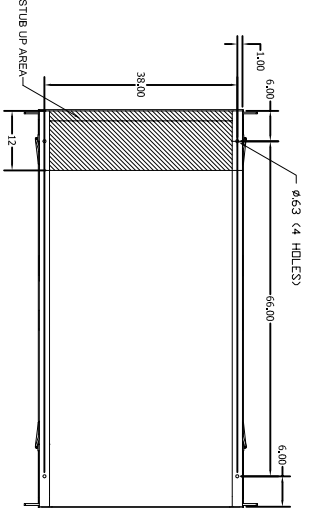
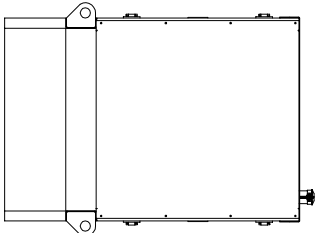
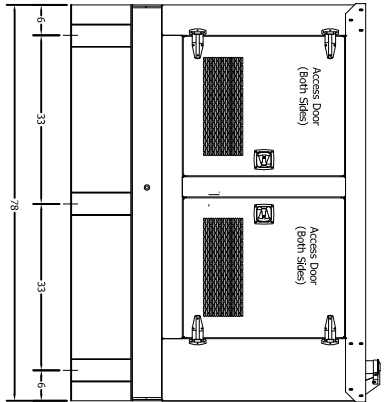
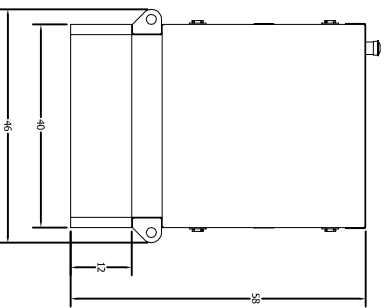
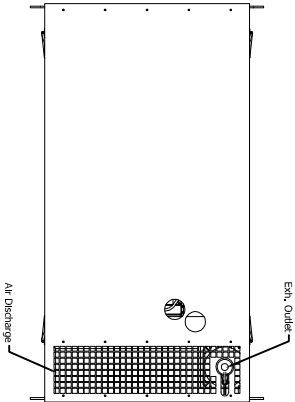

ENCLOSURE MATERIAL: 14 ga. Galvaneal
COLOR: Akzonobel Clay #20-8247HY POWDER COAT

DESIGNER	DATE	TITLE
SWAN	8-21-11	TAYLOR POWER SYSTEMS
CHECKED		
QA		TD13 SOUND ATTENUATED
DRG		ENCLOSURE WITH 80 GAL BASETANK
APPROVED		
SCALE		DWG NO.
		REV