

CUSTOMER APPROVAL SIGNATURE	APPROVAL DATE	COMMENTS
INCLUDED FEATURES		PART #
ENGINE: PERKINS 404D-22G (rated for rough terrain)	GN65733	535 Lbs.
ALTERNATOR: MARATHON 282CS1505	282CS1505	275 Lbs.
SUB-BASE: STRUCTURAL STEEL ISOLATORS	VT087375	126 Lbs.
(4) Barry Controls 256416	VT56416	4 Lbs.
ENCLOSURE: CLAY POWDER COAT, 14 GA STEEL SOUND ATTENUATED ENCLOSURE	VT6R08459	465 Lbs.
FUEL TANK: UL142 270 GALLON DOUBLE WALL	VT364078	1056 Lbs.
SILENCER: SIDE-IN TOP-OUT VERTICAL MOUNT INTERNALLY MOUNTED	VT62302	19 Lbs.
(2) BATTERIES: GGGP-26 STL E 12V BATTERY RACK AND (2) EXTERIOR BATTERY Note: Rack is integral to the skid	VT16056	30 Lbs.
CIRCUIT BREAKER: AMP 400 AB8 ENCLOSURE	MISC	MISC
FUEL LINES/FITTINGS	VT6R03135	MISC
FLUID DRAIN EXTENSION: WITH VALVE ROUTED TO SKID	VT1708N	MISC
CONTROL PANEL	MISC	MISC
HARDWARE: BOLTS, NUTS, WASHERS, LATCHES	MISC	MISC
FLUIDS: OIL & ANTIFREEZE	MISC	MISC
WEIGHT SUBTOTAL		2,510 Lbs.
MISC WEIGHT 5% of subtotal		126 Lbs.
TOTAL WEIGHT:		2,636 Lbs.

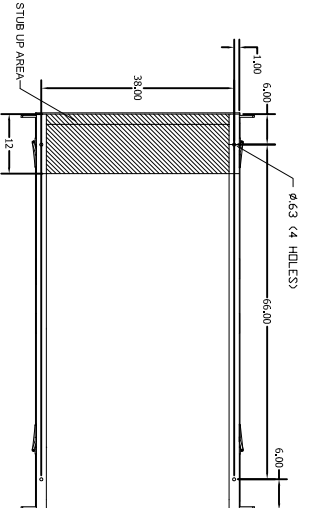
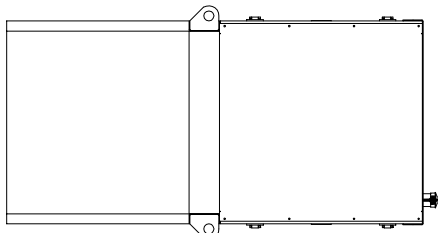
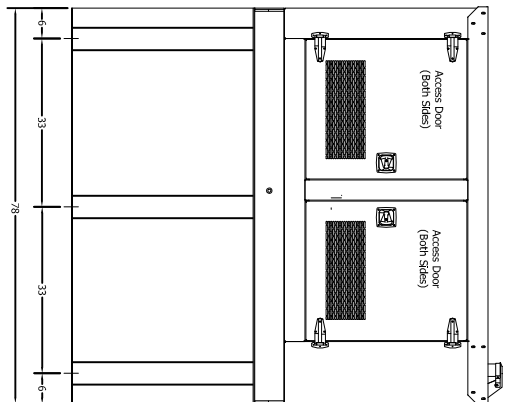
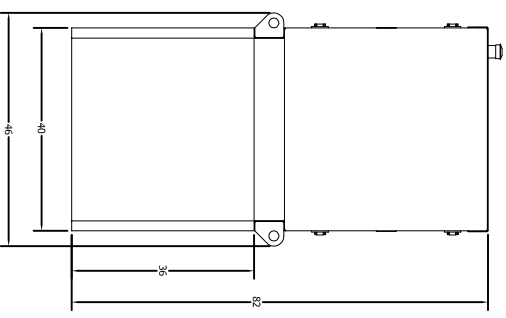
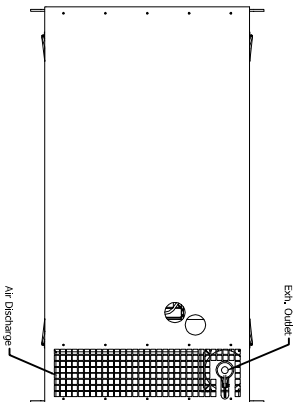

ENCLOSURE MATERIAL: 14 ga. Galvaneal
 COLOR: Akzonobel Clay #20-8247HY POWDER COAT

DESIGN	DATE	TITLE
DRAWN	8-31-11	TAYLOR POWER SYSTEMS
CHECKED		
QA		
MFG		
APPROVED		
SIZE	DWG NO.	REV.
SCALE		