

CUSTOMER APPROVAL SIGNATURE	APPROVAL DATE	COMMENTS
INCLUDED FEATURES		PART #
ENGINE: PERKINS 4140-226 (coolant through flywheel)	0N65733	535 Lbs.
ALTERNATOR: MARATHON 28CCS1505	28CCS1505	275 Lbs.
SUB-BASE: STRUCTURAL STEEL	VT087375	126 Lbs.
ISOLATORS: (4) Berry Controls 256416	VT56416	4 Lbs.
ENCLOSURE: CLAY POWDER COAT, 14 GA. STEEL SOUND ATTENUATED ENCLOSURE	VT6R08499	465 Lbs.
FUEL TANK: UL142 80 GALLON DOUBLE WALL	VT124078	510 Lbs.
SILENCER: SIDE-IN TOP-OUT VERTICAL MOUNT INTERNALLY MOUNTED	VT62302	19 Lbs.
(3) BATTERIES: GROUP 26, STYLE 12V BATTERY RACK AND CABLES FOR BATTERY Note: Rack is integral to the skid	VT6026	30 Lbs.
CIRCUIT BREAKER: AMP ABB ABB ENCLOSURE	MISC.	MISC.
FUEL LINES/FITTINGS	VT6R09135	MISC.
FLUID DRAIN EXTENSION WITH VALVE ROUTED TO SKID	VT1108N	MISC.
CONTROL PANEL	MISC.	MISC.
HARDWARE: BOLTS, NUTS, WASHERS, LATCHES	MISC.	MISC.
FLUIDS: OIL & ANTIFREEZE	MISC.	MISC.
WEIGHT SUBTOTAL		1,964 Lbs.
MISC. WEIGHT 5% of subtotal		98 Lbs.
TOTAL WEIGHT:		2,062 Lbs.

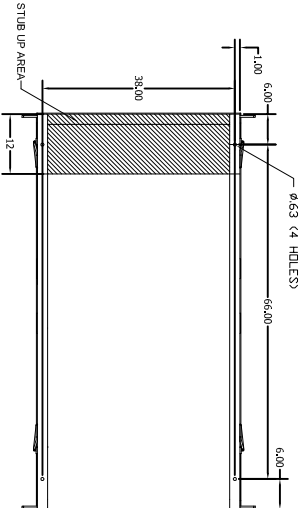
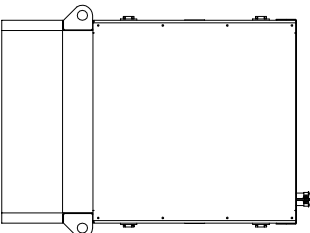
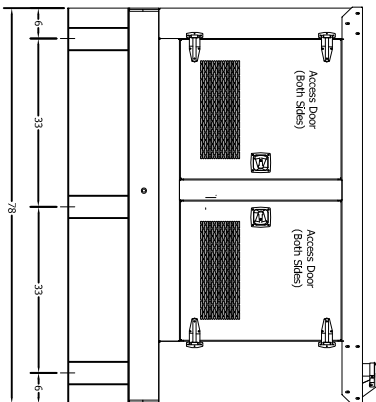
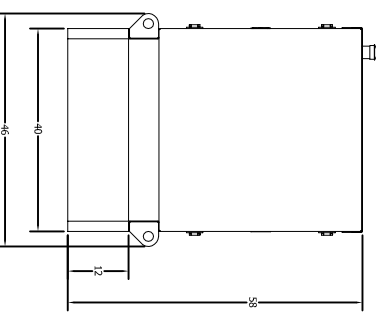
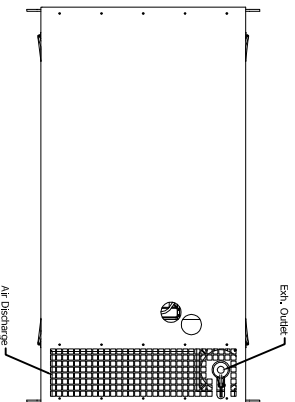

ENCLOSURE MATERIAL: 14 ga. Galvaneal
 COLOR: Akzonobel Gray #20-8247HY POWDER COAT

TAYLOR POWER SYSTEMS

DESIGN	8-31-11	TITLE	TAYLOR POWER SYSTEMS
DESIGNED		DATE	
QA		REV	
APPROVED		SCALE	
		SIZE	
		DWG NO.	
		REV	

TD20 SOUND ATTENUATED
 ENCLOSURE WITH 80 GAL BASE TANK