

CUSTOMER APPROVAL SIGNATURE	APPROVAL DATE	COMMENTS
INCLUDED FEATURES		PART #
ENGINE PERKINS 404D-22G (generator through flywheel)	0165733	535 Lbs.
ALTERNATOR MARATHON 282C3L1505	282C3L1505	275 Lbs.
SUB-BASE STRUCTURAL STEEL	V10817375	126 Lbs.
ISOLATORS (4) Barry Controls 256416	V1256416	4 Lbs.
ENCLOSURE: CLAY POWDER COAT, 14 GA. STEEL STANDARD ENCLOSURE	V16R008459	465 Lbs.
FUEL TANK: U142 270 GALLON DOUBLE WALL	V1364478	1056 Lbs.
SILENCER: STEEL-TOP-OUT VERTICAL MOUNT INTERNALLY MOUNTED	V162302	19 Lbs.
(1) BATTERIES: GROUP 26 STYLE 12V BATTERY RAIL AND CABLES FOR BATTERY Note: Racks is integral to the skid CIRCUIT BREAKER: AMP 400 ABB ENCLOSURE	V16026	30 Lbs.
FUEL LINES/FITTINGS	V16R003135	MISC.
FLUID DRAIN EXTENSION: WITH VALVE ROUTED TO SKID	V170081	MISC.
CONTROL PANEL	MISC.	MISC.
HARDWARE: BOLTS, NUTS, WASHERS, LATCHES	MISC.	MISC.
FLUIDS: OIL & ANTIFREEZE	MISC.	MISC.
WEIGHT SUBTOTAL		2,510 Lbs.
MISC. WEIGHT: 5% of subtotal		126 Lbs.
TOTAL WEIGHT:		2,636 Lbs.

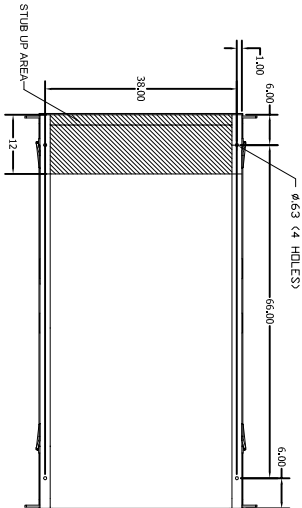
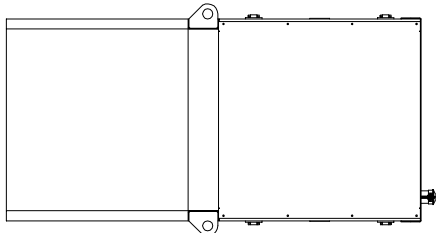
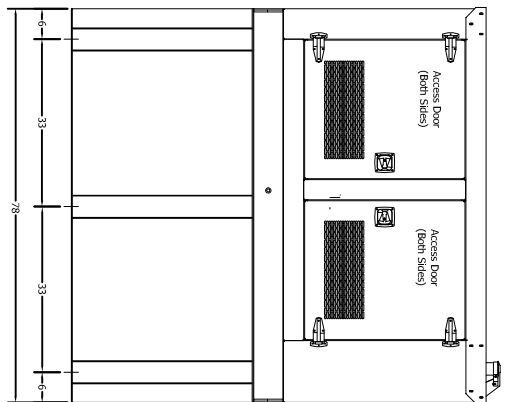
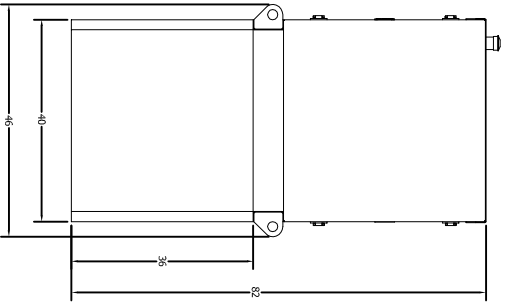
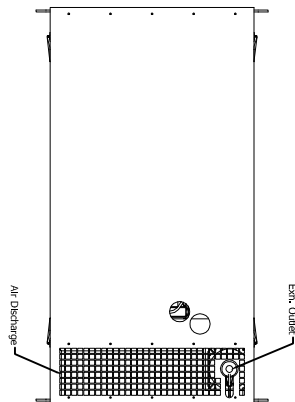

ENCLOSURE MATERIAL: 14 ga. Galvalume
COLOR: AkzoNobel Clay #20-8247HY POWDER COAT

DESIGN	DATE	TITLE
3/11/11	8-31-11	TAYLOR POWER SYSTEMS
DESIGNED		
CHECKED		
QA		
APPROVED		
SIZE		
SCALE		

TD20 STANDARD ENCLOSURE
WITH 270 GAL BASETANK