

CUSTOMER APPROVAL SIGNATURE	APPROVAL DATE	COMMENTS
<b>INCLUDED FEATURES</b>		
ENGINE: PERKINS 4040-226 (credit for through flywheel)	GN65733	535 Lbs.
ALTERNATOR: MARATHON 28CCSL1505	28CCSL1505	275 Lbs.
SUB-BASE: STRUCTURAL STEEL	V1087375	126 Lbs.
ISOLATORS (4) Berry Controls 256416	VT56416	4 Lbs.
ENCLOSURE: CLAY POWDER COAT, 14 GA. STEEL STANDARD ENCLOSURE	VT6R08459	465 Lbs.
FUEL TANK: UL142 80 GALLON DOUBLE WALL	VT124078	510 Lbs.
SILENCER: SIDE-IN TOP-CUT VERTICAL MOUNT INTERNALLY MOUNTED	VT62302	19 Lbs.
(3) BATTERIES: GROUP 26 STYLE 12V BATTERY RACK AND CABLES: FLP BATTERY Note: Rack is integral to the sled	VT6026	30 Lbs.
CIRCUIT BREAKER: AMP ABB	MISC.	MISC.
FUEL LINES/FITTINGS: ABB ENCLOSURE	VT6R09135	MISC.
FLOOD DRAIN EXTENSION: WITH VALVE ROUTED TO SKID	VT108N	MISC.
CONTROL PANEL	MISC.	MISC.
HARDWARE: BOLTS, NUTS, WASHERS, LATCHES	MISC.	MISC.
FLUIDS: OIL & ANTIFREEZE	MISC.	MISC.
WEIGHT SUBTOTAL		1,964 Lbs.
MISC. WEIGHT 5% of subtotal		98 Lbs.
TOTAL WEIGHT:		2,062 Lbs.

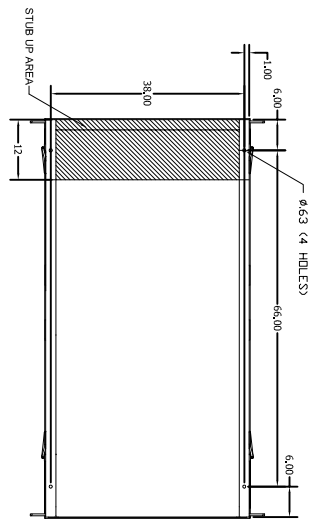
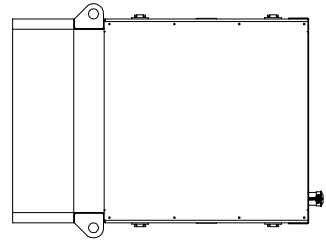
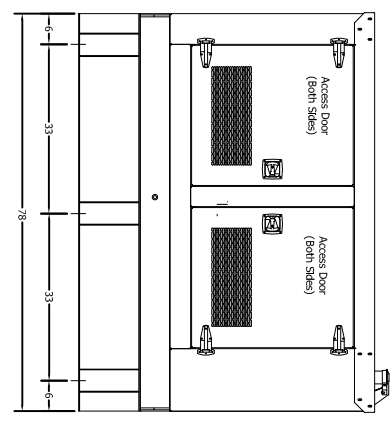
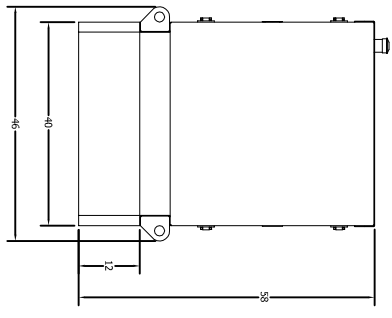
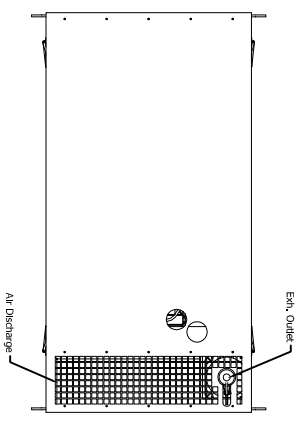

**ENCLOSURE MATERIAL: 14 ga. Galvneal**  
**COLOR: AkzoNobel Clay #20-8247HY POWDER COAT**

FORMAN	DATE	TITLE	SCALE	REV
CHKD	8-31-11	TAYLOR POWER SYSTEMS		
ENGR		TD20 STANDARD ENCLOSURE		
APPROVED		WITH 80 GAL BASETANK		