

CUSTOMER APPROVAL SIGNATURE	APPROVAL DATE	COMMENTS
<b>INCLUDED FEATURES</b>		
ENGINE: PERKINS 400-221G (double through flywheel)	PR65795	535 Lbs.
ALTERNATOR: MARATHON 283CS1507	283CS1507	350 Lbs.
SUB-BASE: STRUCTURAL STEEL	VT0897375	166 Lbs.
ISOLATORS: (4) Barry Controls 256416	VT256416	4 Lbs.
ENCLOSURE: CLAY POWDER COAT, 14 GA. STEEL STANDARD ENCLOSURE	VT18008459	465 Lbs.
FUEL TANK: UL142 80 GALLON DOUBLE WALL	VT124078	510 Lbs.
SILENCER: SIDE-IN TOP-OUT VERTICAL MOUNT INTERNALLY MOUNTED	VT62302	19 Lbs.
(4) BATTERIES: GROUP 26 STILE 12V BATTERY 50 AMP/42 HOUR BATTERY Note: Rack is integral to the sled	VT16066	30 Lbs.
CIRCUIT BREAKER: AMP 400 400 ENCLOSURE		MISC.
FUEL LINES/FITTINGS	VT18003195	MISC.
FLUID DRAIN EXTENSION WITH VALVE ROUTED TO SKID	VT171081	MISC.
CONTROL PANEL		MISC.
HARDWARE: BOLTS, NUTS, WASHERS, LATCHES		MISC.
FLUIDS: OIL & ANTIFREEZE		MISC.
WEIGHT SUBTOTAL		2,039 Lbs.
MISC. WEIGHT: 5% of subtotal		102 Lbs.
<b>TOTAL WEIGHT:</b>		<b>2,141 Lbs.</b>

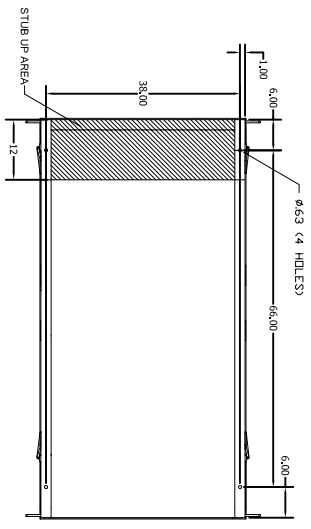
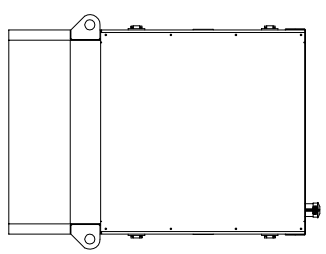
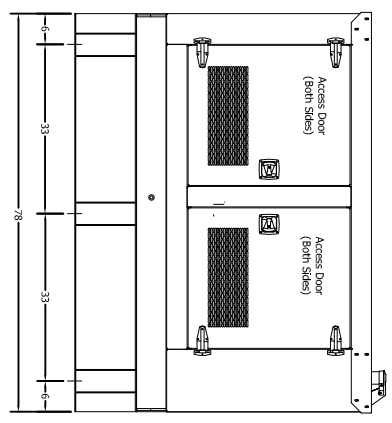
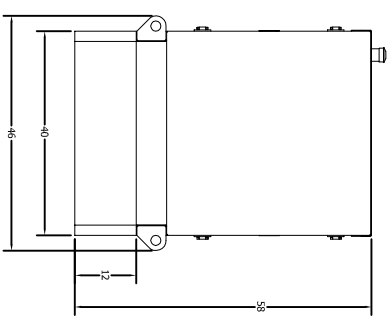
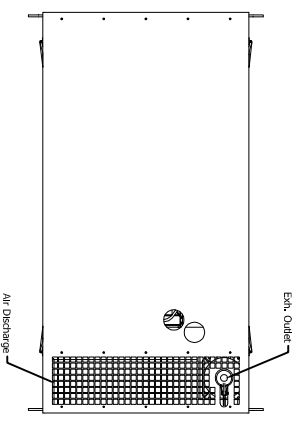

ENCLOSURE MATERIAL: 14 ga. Galvaneal  
 COLOR: Akzonobel Gray #20-8247HY POWDER COAT

**TAYLOR POWER SYSTEMS**

DRAWN: 8-31-11  
 CHECKED: [ ]  
 QA: [ ]  
 MFG: [ ]  
 APPROVED: [ ]

SCALE: [ ] DWG. NO. [ ] REV. [ ]