

CUSTOMER APPROVAL SIGNATURE	APPROVAL DATE	COMMENTS
INCLUDED FEATURES	PART #	WEIGHT
ENGINE: Perkins 404D-22TAG (radiator through flywheel)	VAGR65815	675 Lbs.
ALTERNATOR: MARATHON	283CSL1507	350 Lbs.
SUB BASE: STRUCTURAL STEEL	VT087190	132 Lbs.
ISOLATORS: (4) Barry Controls 256416	VT256416	4 Lbs.
(1) BATTERY: GROUP 26 STYLE 12V BATTERY RACK AND CABLES FOR BATTERY Note: Rack is integral to the skid CONTROL PANEL	VT6026	30 Lbs.
WEIGHT SUBTOTAL		MISC.
MISC. WEIGHT 5% of subtotal		60 Lbs.
TOTAL WEIGHT:		1,251 Lbs.

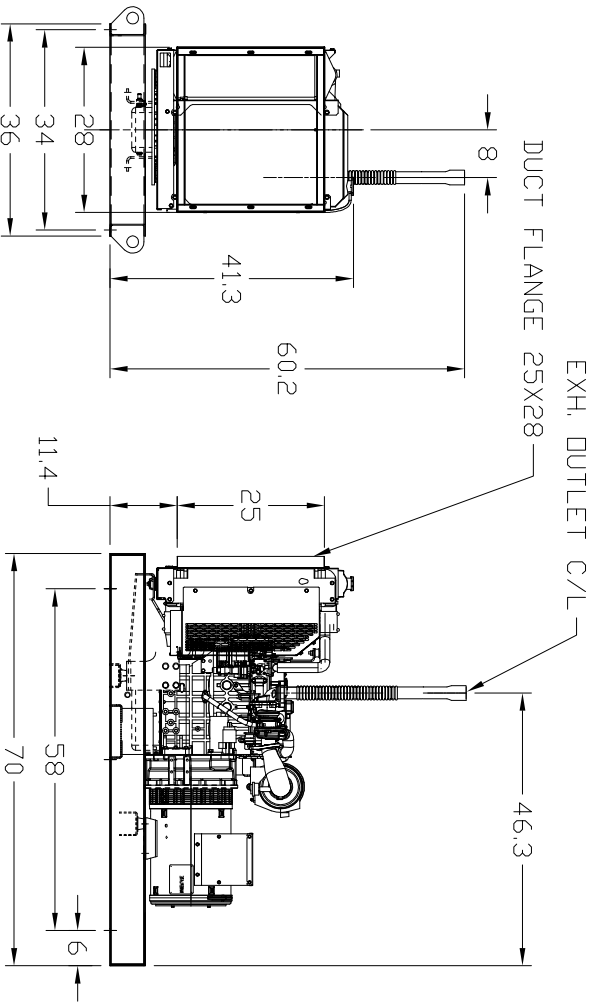
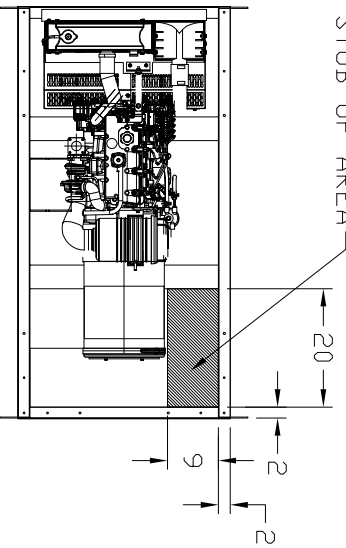

DESIGNER	5/13/2011	TAYLOR POWER SYSTEMS
DATE		
CHKD		
APPROVED		
SIZE		
C	100% 1/0	TD30 OPEN UNIT
SCALE		REV
		REVISED 1, 08-1