

CUSTOMER APPROVAL SIGNATURE	APPROVAL DATE	COMMENTS
INCLUDED FEATURES		PART #
ENGINE PERKINS 4030-116 (radiator through flywheel)		G165598
ALTERNATOR MARATHON 281CSL1502		281CSL1502
SUB-BASE STRUCTURAL STEEL		VT1897375
ISOLATORS (4) Barry Controls 256416		VT256416
ENCLOSURE: CLAY POWDER COAT 14 GA. STEEL STANDARD ENCLOSURE		VT1GR008459
FUEL TANK: UL142 175 GALLON DOUBLE WALL		VT1244078
SILENCER: SIDE-IN TOP-OUT VERTICAL MOUNT INTERNALLY MOUNTED		VT162302
(4) BATTERIES: GROUP 26 STYLE 12V BATTERY PACK AND CABLES FOR BATTERY Note: Rack is integral to the shed		VT161056
CIRCUIT BREAKER: AMP 400 ABB ENCLOSURE		MISC. MISC.
FUEL LINES/FITTINGS		VT1GR003135
FLUID BRAIN EXTENSION: WITH VALVE ROUTED TO SKID		VT1F108N
CONTROL PANEL		MISC.
HARDWARE: BOLTS, NUTS, WASHERS, LATCHES		MISC.
FLUIDS: OIL & ANTIFREEZE		MISC.
WEIGHT SUBTOTAL		1,937 Lbs.
MISC. WEIGHT 5% of subtotal		97 Lbs.
TOTAL WEIGHT:		2,034 Lbs.

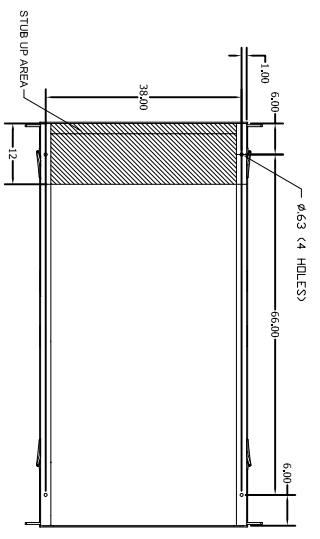
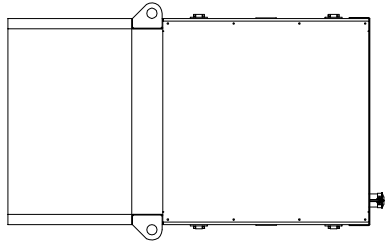
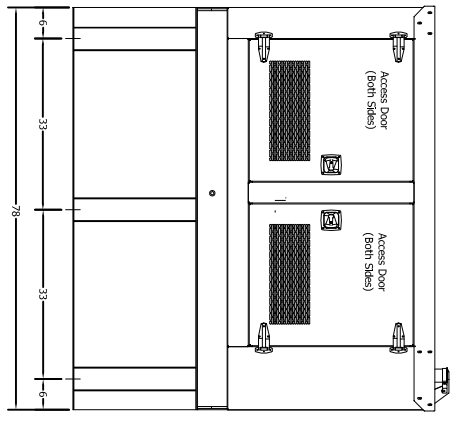
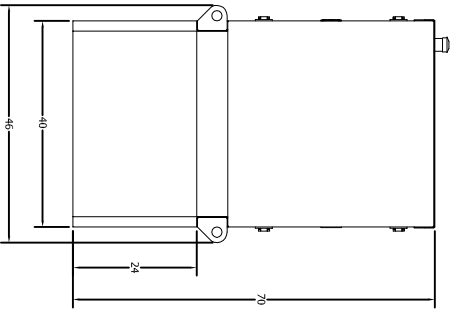
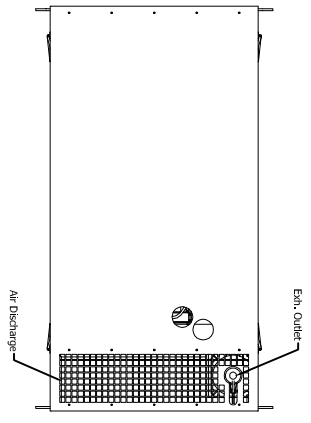

ENCLOSURE MATERIAL: 14 ga. Galvalume
COLOR: AkzoNobel Clay #20-8247HY POWDER COAT

REVISION	DATE	TITLE
DESIGNED	8-31-11	TAYLOR POWER SYSTEMS
CHECKED		TD9 STANDARD ENCLOSURE
DATE		WITH 175 GALLON BASTANK
APPROVED		
SCALE		