

MEC 310

GENSET CONTROLLER

INSTALLATION AND OPERATION MANUAL

r. 0472f



PM075 Rev 2 09/08/20

This description of options covers the following products:

MEC 310

SW version 1.2X.X

Table of Contents

1. ABOUT THIS DOCUMENT	1
GENERAL PURPOSE	1
INTENDED USERS	1
CONTENTS/OVERALL STRUCTURE	1
2. WARNINGS AND LEGAL INFORMATION	3
LEGAL INFORMATION AND RESPONSIBILITY	3
ELECTROSTATIC DISCHARGE AWARENESS	3
SAFETY ISSUES	3
FACTORY SETTINGS	3
DEFINITIONS	3
3. GENERAL PRODUCT INFORMATION	5
INTRODUCTION	5
TYPE OF PRODUCT	5
STANDARD FUNCTIONS	5
OPTIONS	6
4. INSTALLATION INSTRUCTIONS	7
MOUNTING	7
TERMINALS	7
WIRING.....	11
BINARY INPUTS.....	12
CHARGER ALTERNATOR CONNECTIONS.....	13
CONNECTION OF THE 3-PHASE VOLTAGE AND CURRENT	14
CONNECTION OF THE 1-PHASE 2-WIRE VOLTAGE AND CURRENT	14
CONNECTION OF THE 2-PHASE 3-WIRE VOLTAGE AND CURRENT	15
COMMUNICATION	16
TECHNICAL INFORMATION	21
5. PUSH-BUTTONS, LEDS AND DISPLAY	24
UNIT	24
6. FUNCTIONAL DESCRIPTIONS	28
ALARM FUNCTION	28
TIMER FUNCTION	28
MAINS VOLTAGE UNBALANCE DETECTION	29
PHASE SEQUENCE ERROR.....	29
TPS 300 SOFTWARE INPUT CONFIGURATION	29
OUTPUT FUNCTIONS.....	31
ALARM INHIBIT	39
ALARM INDICATION LEDS.....	43
PARAMETER GROUPS	44
LANGUAGE SELECTION	44
TRANSLATION.....	45
FAIL CLASS	46
SERVICE TIMERS	47
COUNTERS	48
COMMAND TIMER	48
CONFIGURABLE VIEWS IN THE DISPLAY.....	50
VDO SENSORS.....	54
BINARY INPUTS WITH CABLE SUPERVISION	58

FUEL PUMP LOGIC	59
ANALOGUE INPUTS 0(4)-20MA	61
RPM INPUTS	62
GENERATOR BREAKER CONTROL	64
TEST FUNCTION	65
M-LOGIC	67
BUZZER	68
UPGRADE OF FIRMWARE	69
GSM COMMUNICATION	74
SMS ALARMS	75
TPS 300 SOFTWARE CONNECTION VIA MODEM	76
TPS 300 SOFTWARE COMMUNICATION SAFETY	77
AUTO ENGINE START	78
START SEQUENCES	79
STOP SEQUENCES	84
5. PARAMETER LIST	86
PARAMETER GROUPS	86
SETUP	86
PARAMETER OVERVIEW	88
FAIL CLASS	90
ENGINE ALARM SETTINGS (PROTECTION)	91
MULTI-INPUTS	95
BINARY INPUTS WITH WIRE BREAK	95
ANALOGUE INPUTS 0(4)-20MA	96
VDO INPUTS	98
RPM INPUT	100
Hz/V MONITORING SETTINGS	107

1. About this document

This chapter includes general user information about this handbook concerning the general purpose, the intended users, the overall purpose and the overall contents and structure.

General purpose

This document is the Installation Instructions and Reference Handbook for Thomson Technology's MEC 310 Generator Controller. The document mainly includes installation instructions, presentation of push-buttons, LEDs and display, functional descriptions and complete standard parameter lists.

The general purpose of the Installation Instructions and Reference Handbook is to provide the information needed to install the unit correctly and to provide information about the functionality of the unit and its applications. The handbook also offers the user the information he needs in order to successfully set up the parameters needed in his specific application.



Please make sure to read this handbook before working with the MEC 310 controller and the gen-set to be controlled. Failure to do this could result in human injury or damage to the equipment.

Intended users

The handbook is mainly intended for the person responsible for installing the unit and for the person responsible for the unit setup. Naturally, others might also find useful information in the handbook.

Contents/overall structure

The Installation Instructions and Reference Handbook is divided into chapters and in order to make the structure of the document simple and easy to use, each chapter will begin from the top of a new page. The following will outline the contents of each of the chapters.

About this document

This first chapter includes general information about this handbook as a document. It deals with the general purpose and the intended users of the Installation Instructions and Reference Handbook. Furthermore, it outlines the overall contents and structure of the document.

Warnings and legal information

The second chapter includes information about general legal issues and safety precautions relevant in the handling of Thomson Technology products. Furthermore, this chapter will introduce note and warning symbols, which will be used throughout the handbook.

General product information

The third chapter will deal with the unit in general and its place in the Thomson Technology product range.

Installation instructions

This chapter includes the information needed to perform correct installation of the unit, e.g. mounting instructions, terminals, wiring, inputs etc.

Push-buttons, LEDs and display

This chapter deals with push-button and LED functions. Furthermore, information about the display including icon list is presented.

Functional descriptions

This chapter includes functional descriptions for the unit's standard functions. Screen dumps and flow charts are used in order to simplify the information.

Parameter list

This chapter includes a complete standard parameter list for setup. Therefore, this chapter is to be used for reference, when information about specific parameters is needed.

2. Warnings and legal information

This chapter includes important information about general legal issues relevant in the handling of Thomson Technology products. Furthermore, some overall safety precautions will be introduced and recommended. Finally, the highlighted notes and warnings, which will be used throughout the document, are presented.

Legal information and responsibility

Thomson Technology takes no responsibility for installation or operation of the generator set. If there is any doubt about how to install or operate the generator set controlled by the unit, the company responsible for the installation or the operation of the set must be contacted.

The units are not to be opened by unauthorized personnel. If opened anyway, the warranty will be lost.

Electrostatic discharge awareness

Sufficient care must be taken to protect the terminals against static discharges during the installation. Once the unit is installed and connected, these precautions are no longer necessary.

Safety issues

Installing the unit implies work with dangerous currents and voltages. Therefore, the installation should only be carried out by authorized personnel who understand the risks involved in working with live electrical equipment.



Be aware of the hazardous live currents and voltages. Do not touch any AC measurement inputs as this could lead to injury or death.

Factory settings

The unit is delivered with certain factory settings. Given the fact that these settings are based on average values, they are not necessarily the correct settings for matching the individual engine. Thus precautions must be taken to check the settings before running the engine.

Definitions

Throughout this document a number of notes and warnings will be presented. To ensure that these are noticed, they will be highlighted in order to separate them from the general text.

Notes



The notes provide general information which will be helpful for the reader to bear in mind.

Warnings



The warnings indicate a potentially dangerous situation which could result in death, personal injury or damaged equipment, if certain guidelines are not followed.

3. General product information

This chapter includes overall product information about the unit in general and its place in the Thomson Technology product range.

Introduction

The concept of the MEC 310 is to offer a simple and effective solution to gen-set builders, who need a flexible yet cost-competitive protection and control unit for small and medium-sized generators.

Type of product

The Generator Controller MEC 310 is a microprocessor-based control unit containing all necessary functions for protection and control of a power generator. Besides the control and protection of the diesel engine it contains a full 3-phase AC voltage and current measuring circuit. The unit is equipped with an LCD display presenting all values and alarms.

Standard functions

Engine control

- Start preparation (preheating or prelubrication)
- Start/stop sequences with selectable number of start attempts
- Fuel solenoid selection (coil type)
- Idle speed control
- Local or remote start/stop
- Stop sequence with cooling down
- Command timers
- Shut down override (fire pump)
- Fuel logic
- Running speed detection selectable
 - Generator Hz/V
 - Charger alternator input (W terminal)
 - Binary input (D+)
 - Oil pressure
 - RPM input

Engine monitoring

- 3 configurable inputs, all selectable between
 - VDO or
 - 0(4)-20mA from active transducer or
 - Binary with cable supervision
- 6 binary inputs, configurable
- RPM input, selectable
 - Magnetic pick-up
 - NPN or PNP pick-up
 - Tacho generator
 - Charger alternator W terminal

Generator monitoring

- 3-phase or single phase generator monitoring
 - Voltage/current/frequency/power factor/power/reactive power

Generator protection (ANSI)

- Over-/undervoltage (27/59)
- Over-/underfrequency (81)
- Overcurrent (51)
- Reverse power (32)
- Voltage unbalance (60)
- Phase sequence error (47)

M-logic

- Simple logic configuration tool
- Selectable input events
- Selectable output commands

Clear text display

- 128 x 64 pixel backlight STN
- Alarm texts editable
- All texts in multi-language
- Clear text alarm messages
- Clear text diagnostics for both hardwired inputs and CANbus messages (J1939)
- Log book holding 150 log entries
- Real time clock for time and date

Options

The basic MEC 310 generator controller unit can be equipped with an AMF option needed to provide a real emergency power system controller. Furthermore, CANbus communication for different engine types is available and CANbus for up to two EAPs is possible at the same time. Also Modbus RS485 is available as an option.



A full options list is included in the data sheet.

4. Installation instructions

This chapter includes the information needed to perform correct installation of the unit, e.g. mounting instructions, terminals, wiring, inputs etc.

Mounting

The unit is designed for flush mounting by means of 4 fixing clamps (IP52), which are included at delivery. To have the IP65 (12 fixing clamps) the unit must be ordered with option L. The two fixing clamps on each side are mounted on the top and bottom of the MEC 310 box.



For Use on a Flat Surface of a Type 1 Enclosure.

Terminals

Unit rear view

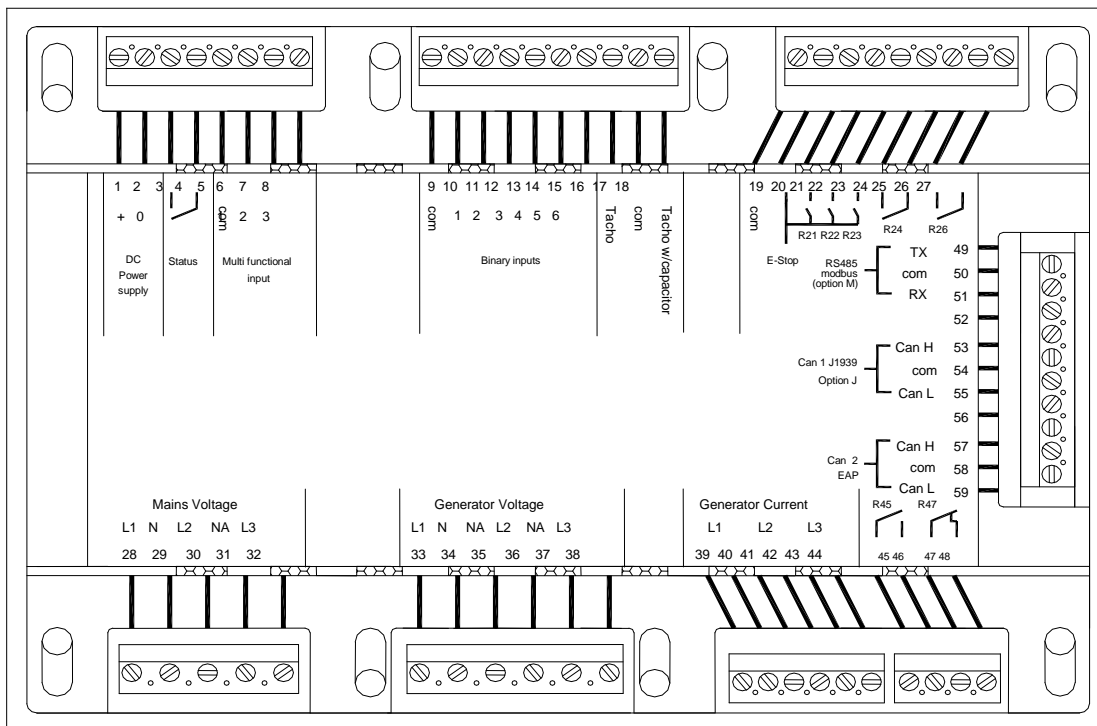

The RJ11 connector for the PC connection interface (SSP) is placed on the side of the unit.

Terminal Description



- **Must be installed in accordance with the NEC (United States) or the CEC(Canada)**
- **Wire size: AWG 30 – 12 (or equivalent)**
- **Use 60/75°C copper conductors only**
- **Tightening torque: 5-7 lb-in (or equivalent)**
- **Main disconnect shall be provided by installer**

Term.	Technical data	Description
1	Power supply +	6...36V DC (UL/C-UL: 7.5...32.7V DC)
2	Power supply –	GND
3-4	Status out. Contact ratings 1A 24V DC/V AC Resistive	General status output for marine approvals**
9	Common	Common for term. 10...15
10	Digital input	Start enable/configurable
11	Digital input	Remote start/stop/configurable
12	Digital input	Charge alternator D+ (running)/configurable
13	Digital input	Configurable
14	Digital input	Coolant temperature/configurable
15	Digital input	Oil pressure/configurable
19	Common	Common for emergency stop term. 20
20	Emergency stop and common for 21...23	Common for relay 1, 2 and 3 and input for emergency stop*
21	Relay output 21. Contact ratings 2A 30V DC/V AC (UL/C-UL: 1A Resistive)	Start prepare/configurable. Function NO
22	Relay output 22. Contact ratings 2A 30V DC/V AC (UL/C-UL: 1A Resistive)	Starter (crank)/configurable. Function NO
23	Relay output 23. Contact ratings 2A 30V DC/V AC (UL/C-UL: 1A Resistive)	Run coil/stop coil/configurable. Function NO
24-25	Relay output 24. Contact ratings 8A 30V DC/V AC (UL/C-UL: 6A Resistive)	Horn/configurable. Function NO
26-27	Relay output 26. Contact ratings 8A 30V DC/V AC (UL/C-UL: 6A Resistive)	Alarm/configurable. Function NO
Multi-functional inputs		
5	Common	Common for term. 6...8
6	VDO1/4...20mA/binary input	Fuel level/configurable
7	VDO2/4...20mA/binary input	Oil pressure/configurable
8	VDO3/4...20mA/binary input	Water temp./configurable
Tacho RPM input		
16	RPM input (MPU)	Magnetic pick-up/tacho generator
17	RPM-GND	Common for RPM input
18	RPM input (W/L)	Magnetic pick-up. PNP, NPN or charge alternator W terminal
3-phase generator voltage input		
33	Gen. voltage L1	Generator voltage and frequency
34	Gen. neutral	
35	Not used, must not be connected	
36	Gen. voltage L2	
37	Not used, must not be connected	
38	Gen. voltage L3	
3-phase generator current input		
39	Gen. current L1, s1	Generator current. Use listed or R/C (XODW2,8) current transformer.
40	Gen. current L1, s2	
41	Gen. current L2, s1	
42	Gen. current L2, s2	

43	Gen. current L3, s1	
44	Gen. current L3, s2	
Optional 3-phase mains voltage inputs (option A)		
28	Mains voltage L1	
29	Mains voltage neutral	
30	Mains voltage L2	
31	Not used, must not be connected	
32	Mains voltage L3	
Breaker relays		
45	Relay R45 Contact ratings 2A 30V DC/250V AC (UL/cUL Listed: Contact ratings 2A 30V DC/30V AC)	Generator circuit breaker/configurable, function NO (normally open).
46	Relay R45	
Optional relay for closing mains breaker (option A)		
47	Relay R47 Contact ratings 2A 30V DC/250V AC (UL/cUL Listed: Contact ratings 2A 30V DC/30V AC)	Mains circuit breaker/configurable, function NC (normally closed). Option A.
48	Relay R47	
Optional Modbus RS485 interface (option M)		
49	B (-)	Modbus RS485 RTU or ASCII
50	GND	
51	A (+)	
Optional CANbus engine interface (option J)		
53	CAN-H	CAN J1939 engine communication
54	CAN-GND	
55	CAN-L	
Optional CANbus port #2: External I/O interface (feature EXP)		
57	CAN-H	CAN communication port to External I/O
58	CAN-GND	
59	CAN-L	

* If terminal 20 is used for emergency stop, please see wiring diagram on page 15.

** The status relay is the uP watchdog output. This relay is normally energised, and the switch is closed after power-up. If the uP fails or the power is lost, the relay will de-energize and the switch will open. If the unit fails to start up at power-up, then the relay switch will remain open.

The binary output functions are configurable via the TPS 300 software and can be configured to cover the following functions:

- Alarm/limit
- Engine running
- Horn
- Idle speed
- Not used
- Start prepare
- Run coil
- Starter
- Stop coil
- External heater
- Stop coil (not acc. in start seq.)
- Fuel pump

It is possible to choose run coil on one relay and stop coil on another, thus supporting engines with double systems.

The multi-functional inputs can be configured to cover the following functions:

- VDO sensor input
- 0...20mA input
- 4...20mA input
- Binary input with the possibility of cable supervision

Tacho RPM input (MPU) can be configured to cover the following functions:

- Magnetic pick-up (2-wire)
 - NPN or PNP pick-up*
- * These RPM inputs require external equipment.

Tacho RPM input with capacitor (M/L) can be configured to cover the following functions:

- Magnetic pick-up (2-wire)
 - W terminal on charger alternator
 - NPN or PNP pick-up*
- * These RPM inputs require external equipment

The generator voltage and current input can be configured to the following:

- Voltage 100...25000V primary
- Current 5....9000A primary

Wiring

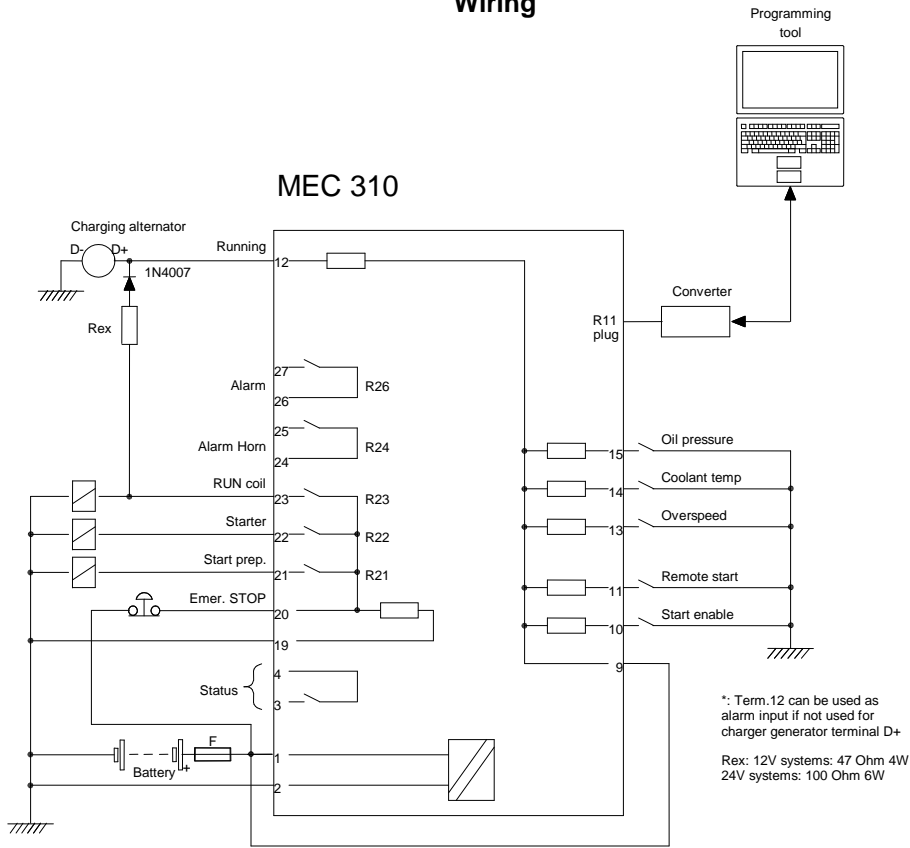

<p>Engine communication option</p>	<p>Modbus option</p>	<p>External I/O and EAP300 feature</p>
<p>Multi-functional inputs VDO sensors</p>	<p>Multi-functional inputs 4-20 mA transmitters</p>	<p>Multi-functional inputs Binary input w. cable superv.</p> <p>R= 100 Ohm</p>
<p>Tacho input Magnetic pickup/ Tacho generator</p>	<p>Tacho input NPN/PNP pickup</p>	<p>Tacho input W input from charger alternator</p>

- i** If a stop coil is used, the REX resistor can be connected to the starter relay (crank).
- i** The illustrated configuration is the default factory setting. The use of the relays can be chosen freely.
- i** It is important to protect the unit against damage caused by high voltages. Therefore, the fuse must not be more than 2A.

Binary inputs

All binary inputs are 12/24V DC bi-directional optocoupler type. The typical wiring is illustrated below:

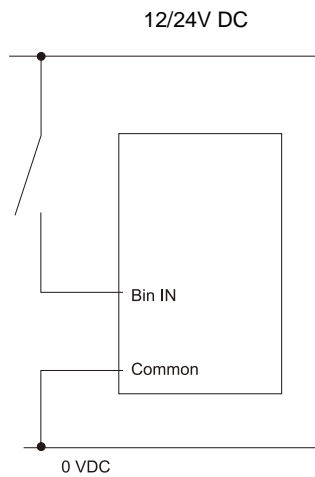

- i** The binary inputs use fixed signals. Only the mode shift input and the test input (if the timer is used) use pulse signal.

Charger alternator connections

The charger alternator can be connected in 2 different ways:

- 1) Using the D+ terminal connected to terminal 12
- 2) Using the W terminal connected to the RPM input



Usually only one of these possibilities is used.

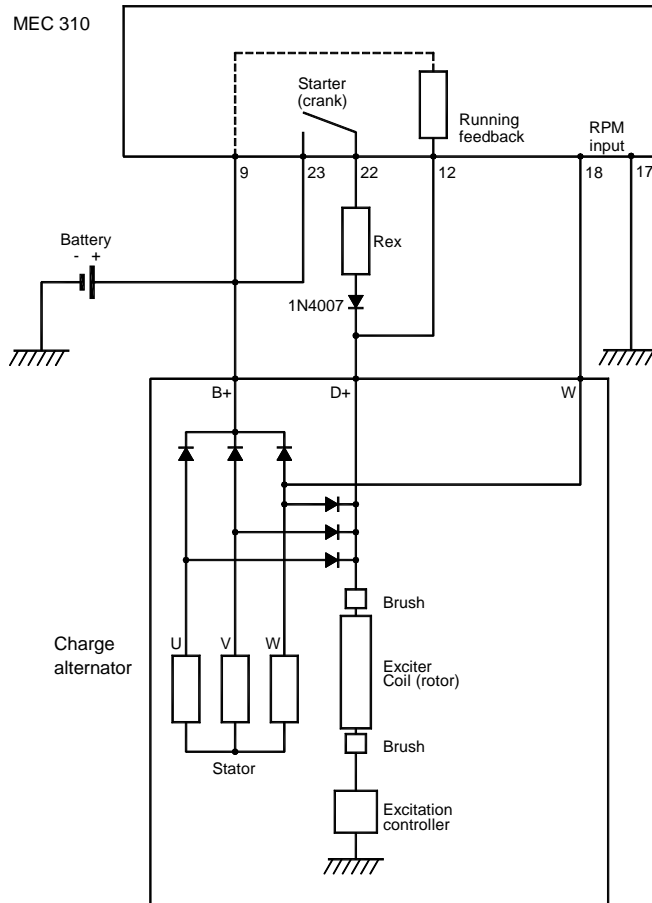

Rex: Excitation resistor	12V systems: 47Ω 4 W
	24V systems: 100Ω 6 W

At standstill the battery + is connected to terminal 9 (common), and a current flows to terminal 12 and via the D+ input on the alternator to ground (battery -). When the starter is engaged (cranking), the battery will supply the D+ through the REX resistor, helping the alternator to excite. When the alternator starts to produce voltage (excitation OK), the speed of the alternator will be above running speed, and the voltage on term. 12 will rise to a value higher than the battery voltage and then interrupt the current flow through REX and activate the running feedback input. Engine is running.



If a stop coil is used, the REX resistor can be connected to the starter relay (crank).

Connection of the 3-phase voltage and current

Wiring, AC interface

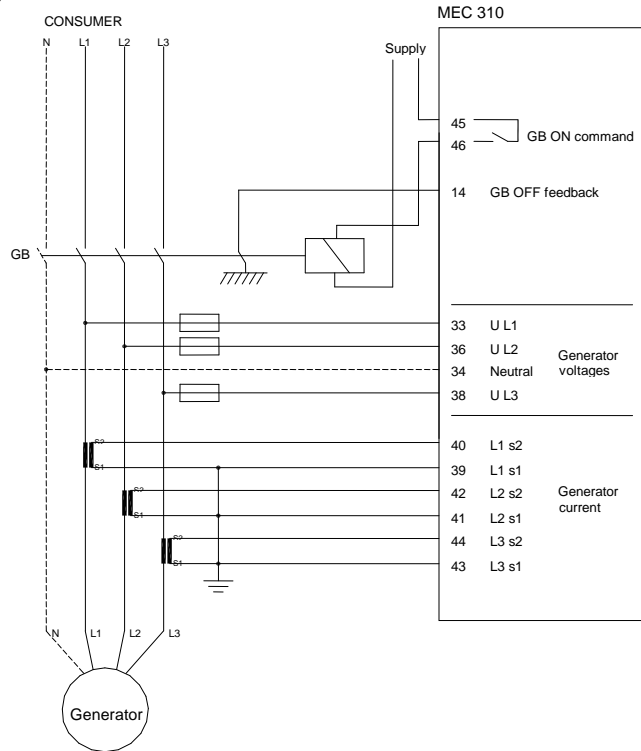

Connection of the 1-phase 2-wire voltage and current

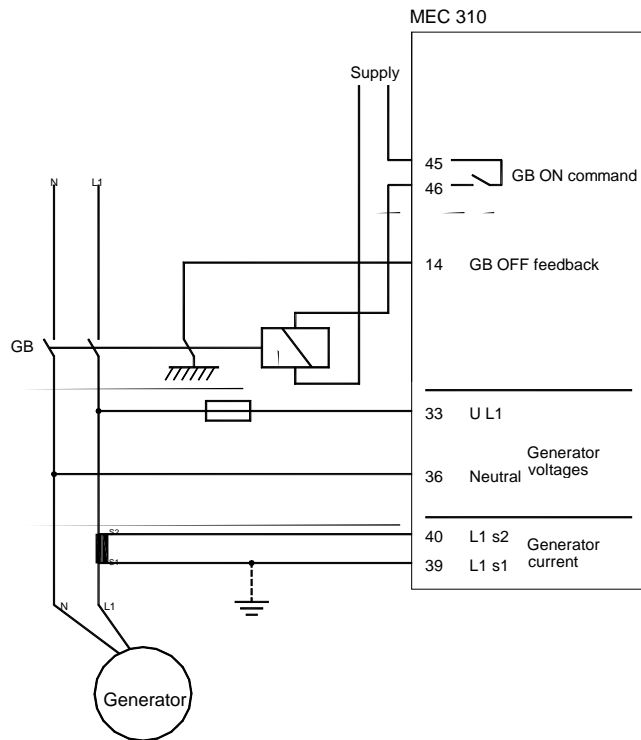

Connection of the 2-phase 3-wire voltage and current

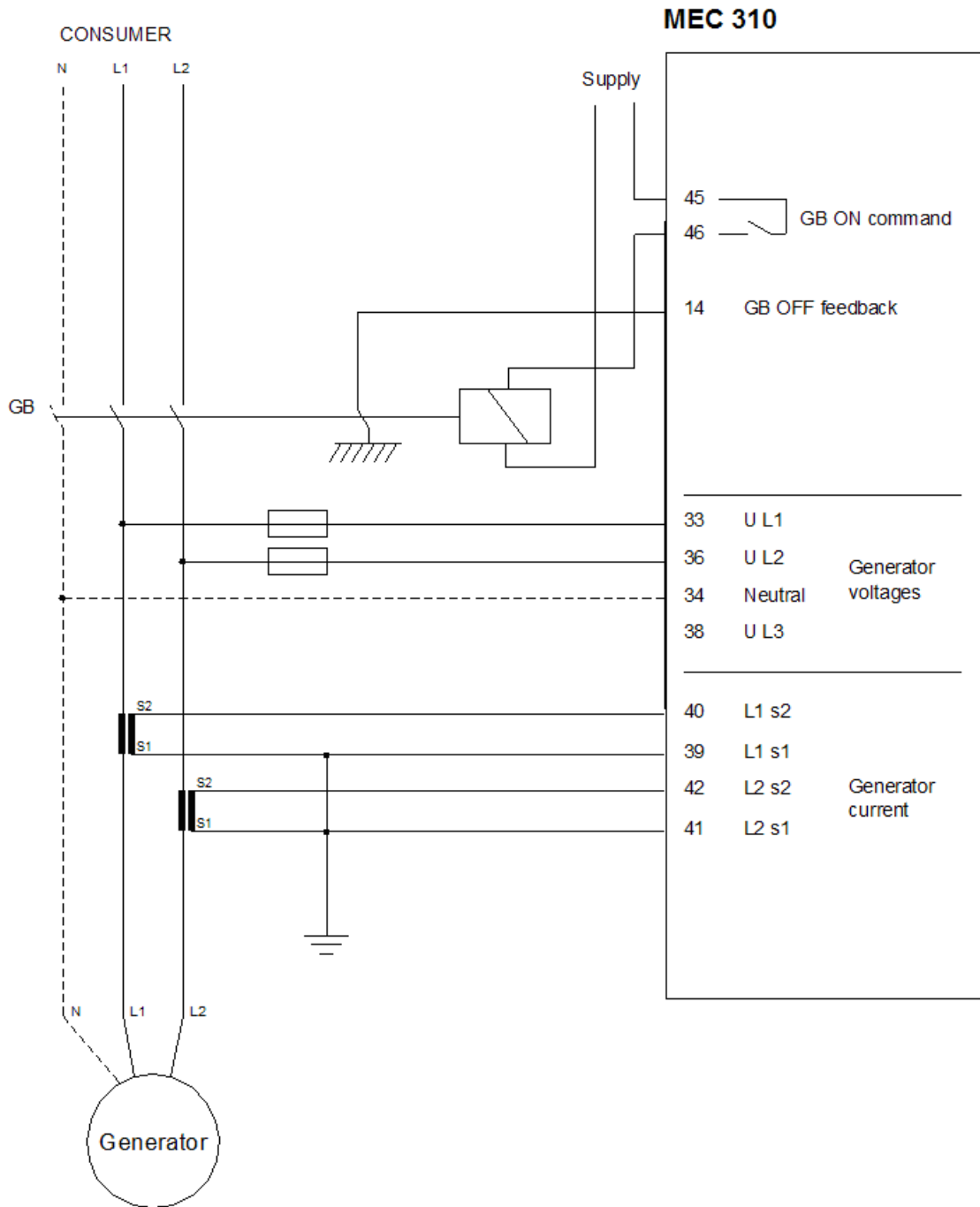

Communication

Wiring instructions

Cable

Belden 3106A or equivalent. 22 AWG (0.324 mm²) shielded twisted pair, min. 95% shield coverage.

Cable shield

Connect the cable shield to earth at one end only.

GND terminal connection

In case of communication problems, the GND terminals of the MEC 310 unit and the external device can be linked together using a third wire.

CANbus Termination resistor

The size of the terminating resistors should be 120Ω 1%, 0.5W resistor.



Never connect the GND terminal to earth directly or through the shield!



If the GND terminal is connected to a PLC or other device, the GND connection of this device must be isolated from earth!



Maximum length of the CANbus line is 400m.

Option M, Modbus RTU

Connection with 3-wire shielded cable:

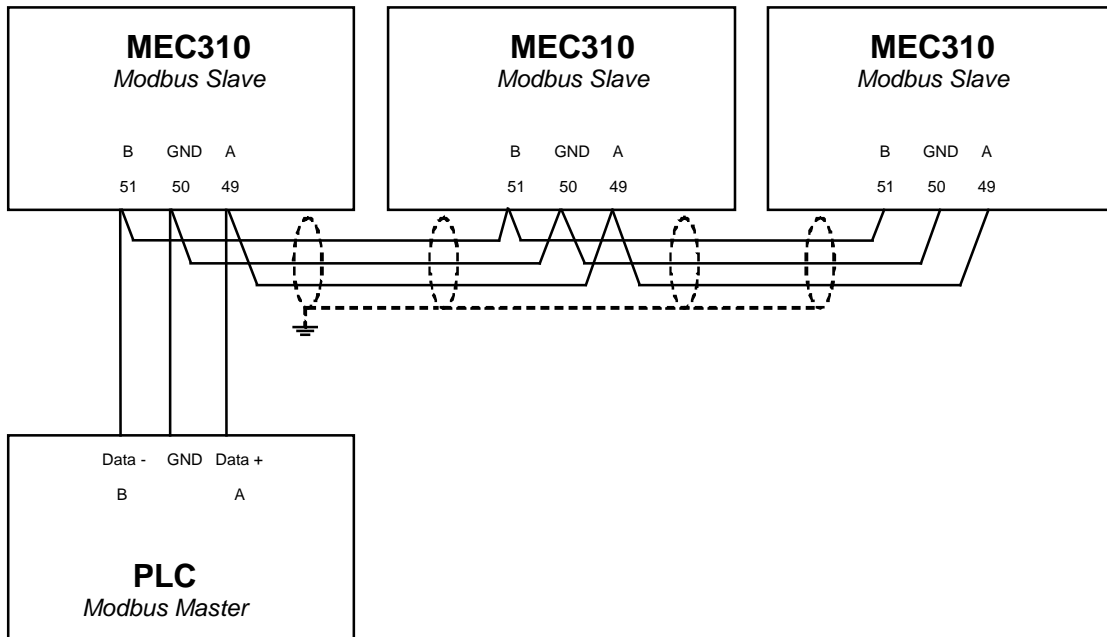



For wiring details, please refer to 'Wiring instructions' in this section.



In case of very long lines on the network, terminating resistors might be needed (typically 120 Ω 1%, 0.5W).



The calculation should be based on the following data:

- A line internal pull-up bias resistor: 22 k Ω
- B line internal pull-down bias resistor: 22 k Ω
- Receiver input sensitivity: +/-200 mV
- Receiver input impedance: 12 k Ω

Option J, CANbus engine communication

Connection with 2-wire shielded cable (recommended):

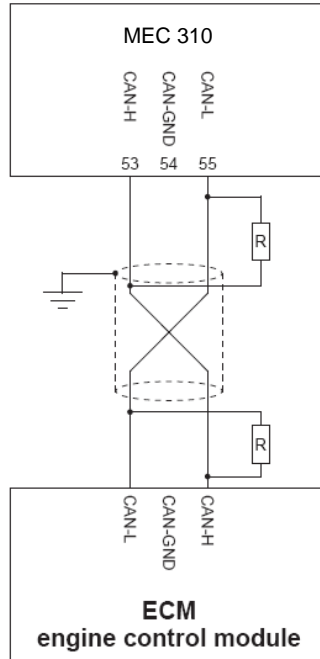

Connection with 3-wire shielded cable:

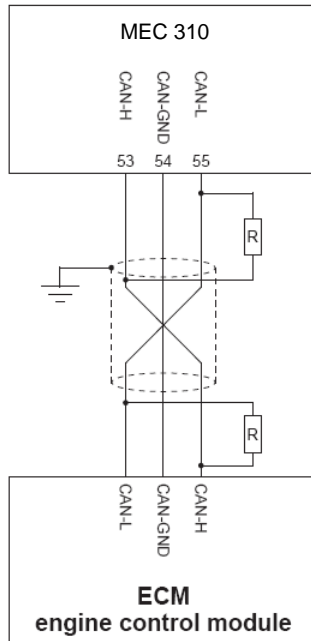

For wiring details, please refer to 'Wiring instructions' in this section.

External I/O modules

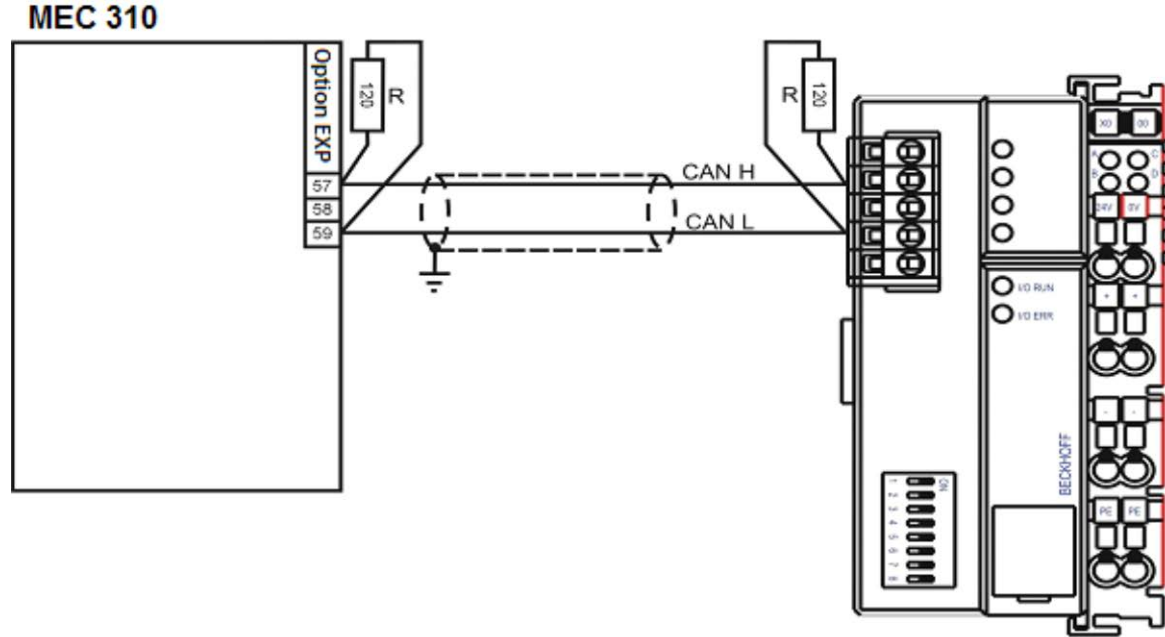

For wiring details, please refer to 'Wiring instructions' in this section.



If External I/O modules is used together with EAP 300, the total terminal resistance of the EAP 300 and the External I/O controller must be 120Ω

Additional operator's panel EAP 300

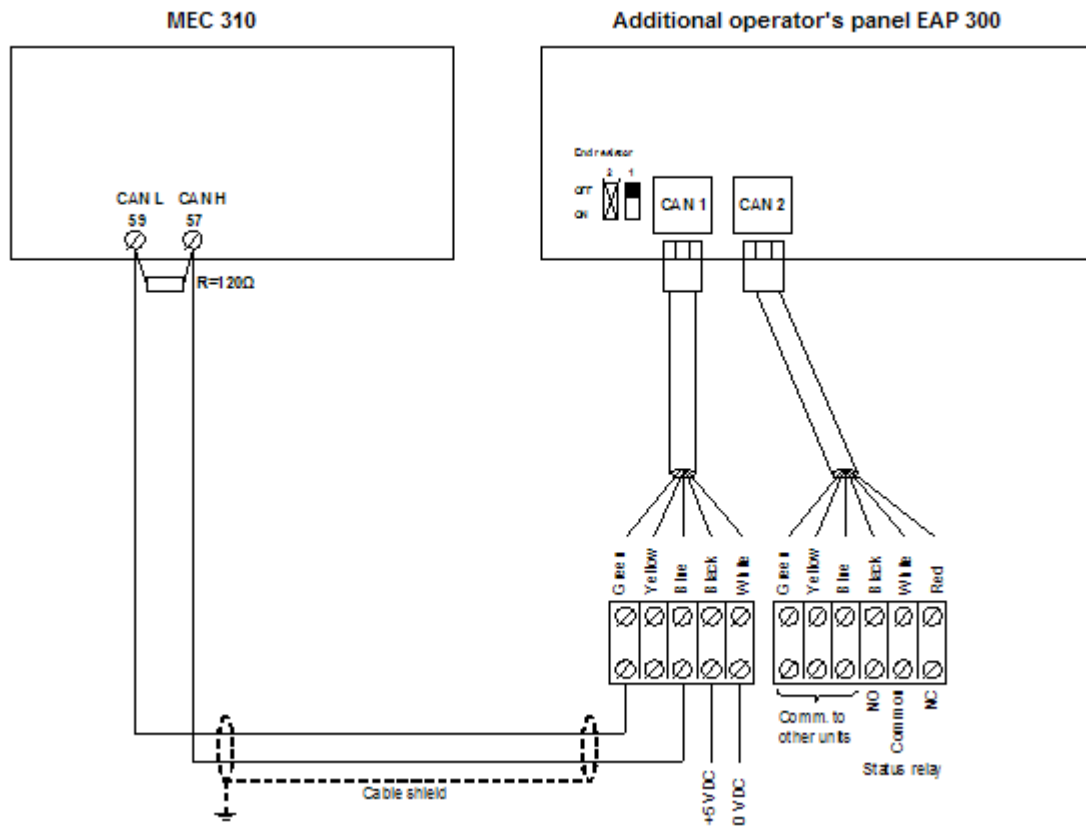

For wiring details, please refer to 'Wiring instructions' in this section.



If the External I/O modules are used together with EAP 300, the total terminal resistance of the EAP 300 and the External I/O controller must be 120Ω



A DC/DC converter for the DC supply voltage and 2x1m cable with an RJ12 plug in one end and stripped wires in the other end is included in the EAP 300 delivery.

Technical information**Technical specifications**

Accuracy:	Class 2.0 to EN 60688/IEC 688
Galvanic separation:	Between inputs and aux. power supply: 500V DC – 1 min.
Connections:	1.5 mm ² multi stranded
Operating temperature:	-20...70°C (-4...158°F) (UL/cUL Listed: Max. 50°C ambient)
Storage temperature:	-40...70°C (-40...158°F)
Aux. supply:	6-36V DC (UL/cUL Listed: 7.5...32.7V DC) continuously Max. 8W consumption
Measuring input voltage:	50...480V AC phase to phase (+20%)
Load:	1.5MΩ
Measuring input current (In):	1A or /5A AC from current transformer
Load:	Max. 0.3VA per phase
Frequency:	30...70Hz
Analogue input:	From active transducer
Current:	0(4)...20mA
Impedance:	50Ω Wire break: I < 2.5mA = Fault Response times: 500ms

(From the set point is reached till the output is activated or the delay timer is started).

Multi inputs:	Resistor inputs, internal 3V supply Wire break: R > 150Ω Response times: 500ms
---------------	--

(From the set point is reached till the output is activated and the delay timer is started).

Active binary inputs:	Dry contact inputs with wire break
Internal voltage:	3V DC
Impedance:	240Ω ~ 16mA
RPM input:	2.0...70V 10...10,000Hz
Passive binary in voltage:	Bi-directional optocoupler 6...36V DC

Relay outputs:	3 relays (R21-R23): 30V DC/AC 2A (UL/cUL Listed: 1A Resistive) 2 relays (MB & GB): 250V AC 30V DC 2A (UL/cUL Listed: Contact ratings 30V DC/30V AC 2A resistive) 2 relays (R24 & R26): 30V DC/AC 8A (UL/cUL Listed: 6A Resistive) 1 status relay: 24V DC 1A Resistive
Mounting:	Panel mounted
Size:	160 x 220mm
EMC/CE:	To EN 61000-6-1/2/3/4 SS4631503 (PL4) and IEC 255-3
Material:	All plastic materials are self-extinguishing according to UL94
Plug connections:	AC voltage inputs: 3.5 mm ² multi stranded (13 AWG) Other: 1.5 mm ² multi stranded (16 AWG)
Tightening torque, min.:	AC voltage input: 0.5Nm Other: 0.5Nm
PC connection:	RS232 converter box (option J5)
Approval:	CE & UL/cUL listed
Weight:	Approx. 0.9 kg (2.0 lbs)
UL/cUL demands:	Use 60/75°C copper conductors only Main disconnect must be provided by installer Installed in accordance with the NEC (United States) or the CEC (Canada) Use listed or R/C (XODW2,8) current transformers

Unit dimensions and panel cutout

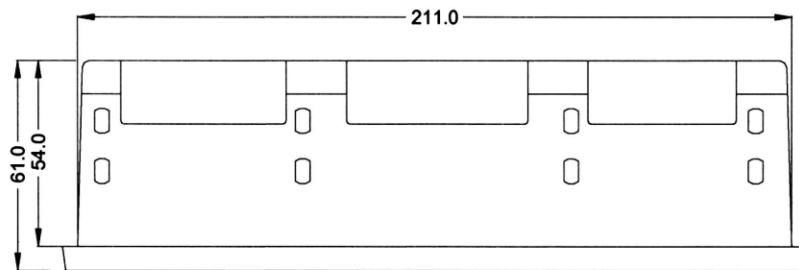
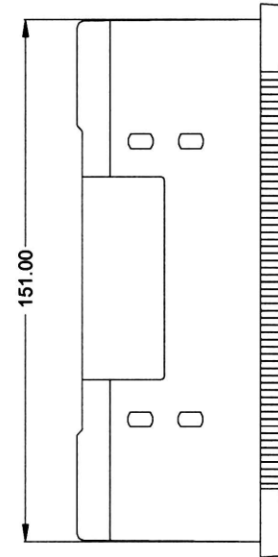

Panel cutout
 H x W = 151 x 211 +1 mm
 H x W = 5.94" x 8.31" +0.04"

5. Push-buttons, LEDs and display

This chapter deals with the display including the push-button and LED functions.

Unit

Front dimensions H x W	160 x 220 mm (6.30" x 8.66")
Unit depth	54 mm (2.13 ")

Push-button functions

The push-buttons on the unit have the following functions:

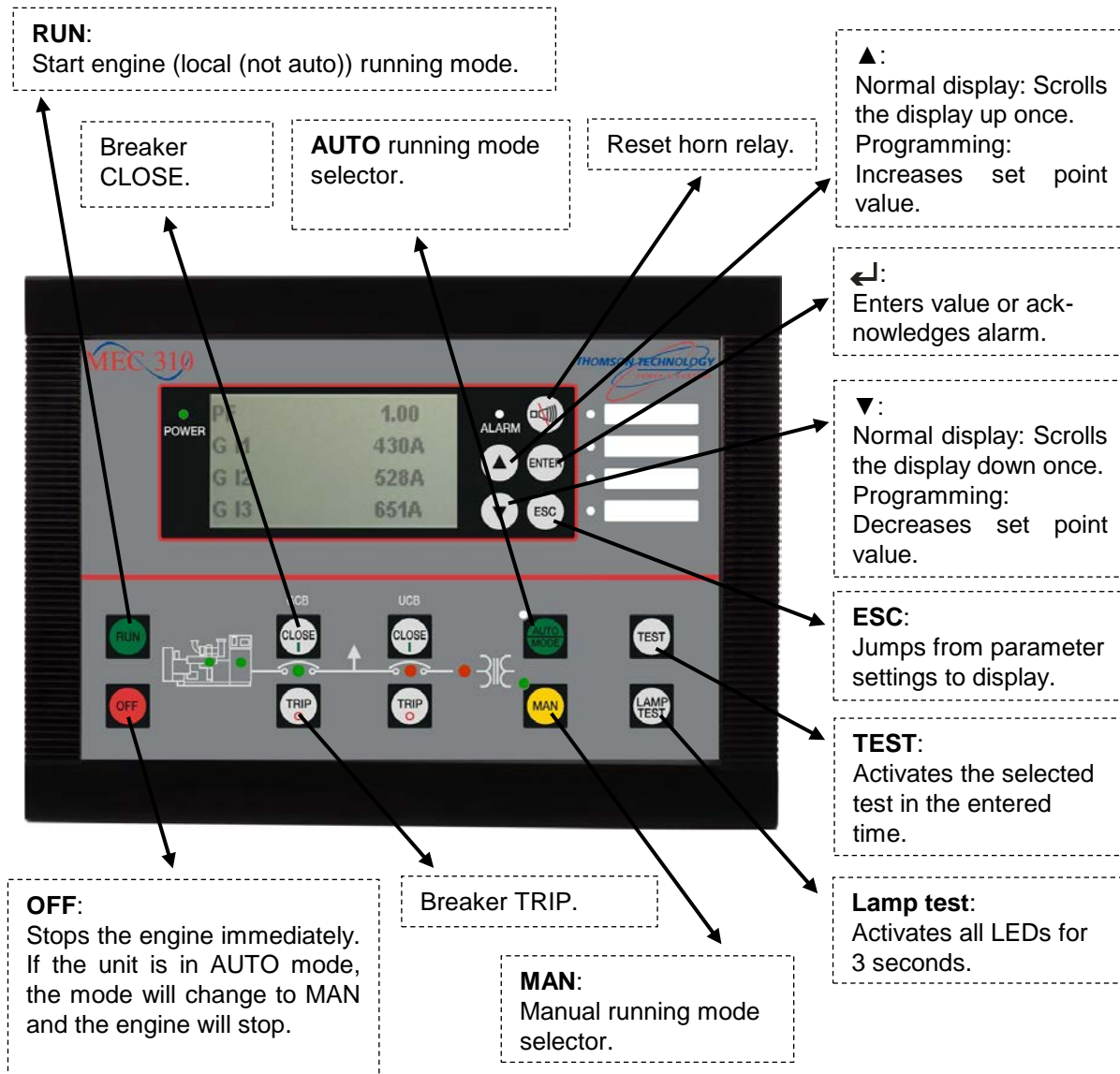

RUN:	Start engine (local (not auto)) running mode.
OFF:	Stops the engine instantaneously. If the unit is in AUTO mode, the mode will change to MANUAL and the engine will stop.
TRIP:	Trip the breaker.
CLOSE:	Close the breaker.
AUTO:	AUTO running mode selector.
MAN:	Manual running mode selector.
TEST:	Initiates the test sequence selected for the push-button.
LAMP TEST:	Lamp test. One push will illuminate all LEDs for 3 seconds.
ESC:	Jumps from parameter settings to display. Removes pop-up messages.
 :	Resets horn relay. Press 2 seconds to jump to the alarm list.
▲:	Normal display: Scrolls the display up once. Programming: Increases set point value.
▼:	Normal display: Scrolls the display down once. Programming: Decreases set point value.
ENTER:	Enters value/acknowledges alarm.

LED functions

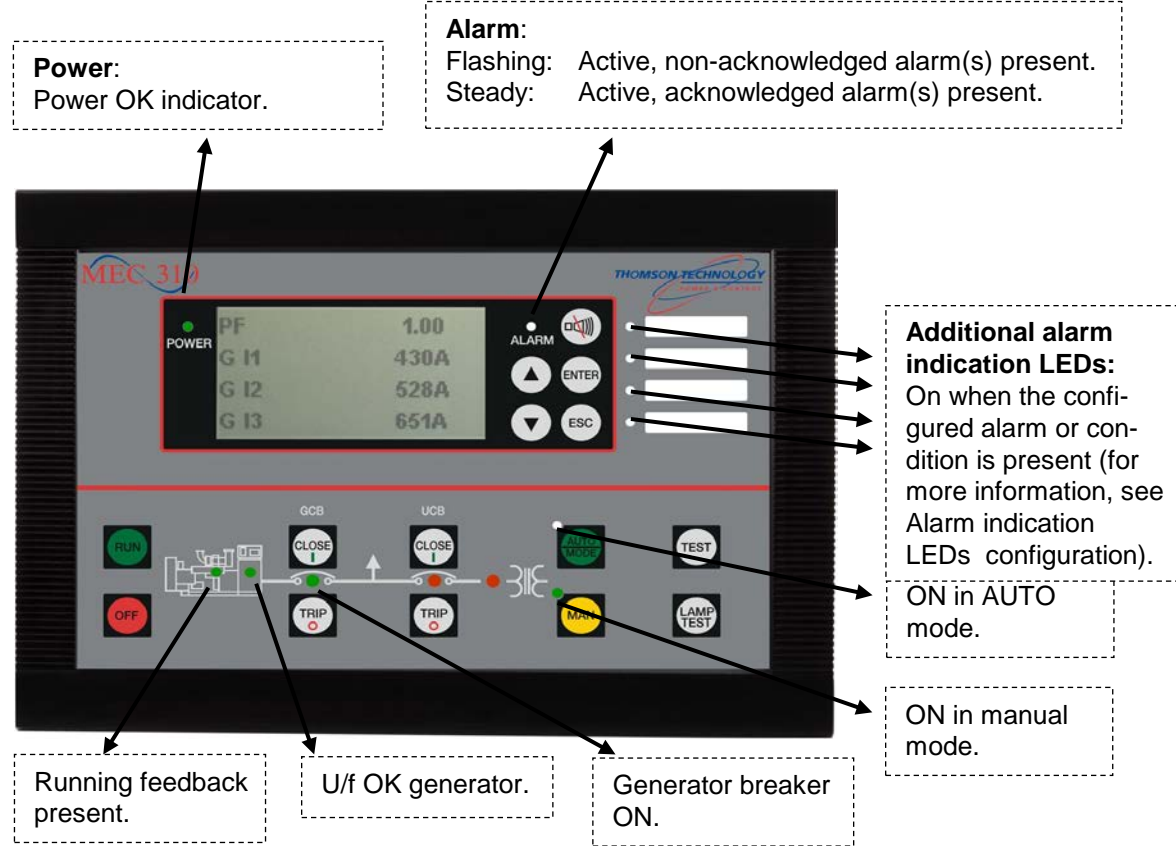

Power: Power OK indicator.

Alarm: Flashing: Active, non-acknowledged alarm(s) present (factory setting).
Steady: Active, acknowledged alarm(s) present (factory setting).

The alarm LED can also be adjusted to:

- Flashing (red): Active, non-acknowledged shutdown alarm(s) present.
- Steady (red): Active, acknowledged shutdown alarm(s) present.
- Flashing (amber): Active trip stop alarm, trip GB alarm or warning non-acknowledged alarm(s) present.
- Steady (amber): Active trip stop alarm, trip GB alarm or warning acknowledged alarm(s) present.



This is adjusted in parameter 6940.

Additional alarm indication LEDs:

- Flashing (red): Active, non-acknowledged alarm(s) where output A or B is configured to LED 1, 2, 3 or 4.
- Steady (red): Active, acknowledged alarm(s) where output A or B is configured to LED 1, 2, 3 or 4.

Alarm: Flashing (red): Active, non-acknowledged alarm(s) present (factory setting).
Steady (red): Active, acknowledged alarm(s) present (factory setting).

Display functions

The display indicates both readings and alarms. Illustrated below are examples with icons and English language.



Type and software version.

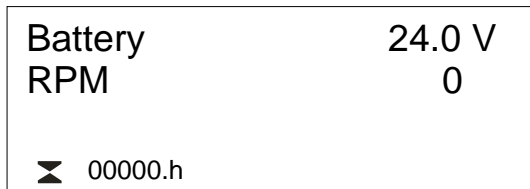

Battery voltage, RPM and running hours counter.

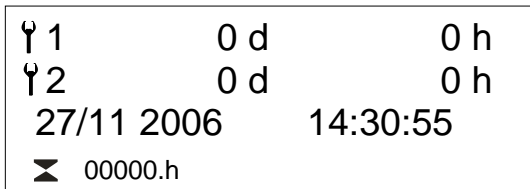

Service timer 1 and 2.

Date and time.

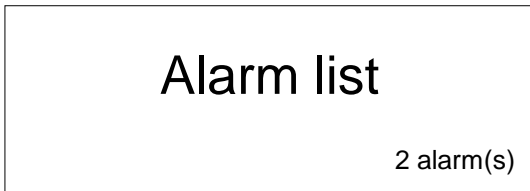

Press **↵** to enter the list of active alarms.

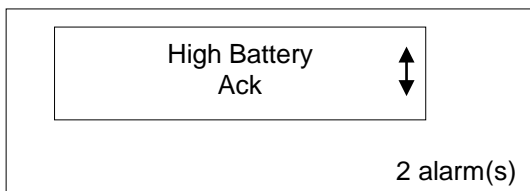

Active alarm list. The alarm list pops up automatically, when an alarm appears. When the arrow is present, more alarms are active. Press **▼** to scroll through the list. Exit the list by pressing ESC.



Press **↵** to enter the parameter setting.



Min. value Actual value Max. value

Parameter example: D+ delay setting. Use **▲** or **▼** to scroll through the settings list. If change of settings is necessary, press **↵** and enter the password. Then use **▲** or **▼** to change values. Use ESC to leave settings.



The available parameters depend on the set options. Some parameters can only be changed using the TPS 300 software. The parameter list will automatically be abandoned, if no button is pressed during a 30 sec. period.





6. Functional descriptions

This chapter includes functional descriptions for the unit's standard functions. Screen dumps and flow charts are used in order to simplify the information.

Alarm function

The unit will detect and display individual alarms that are enabled. Furthermore, it is possible to activate relays for alarm purposes. The alarms can be configured to any of the available relay outputs. Each alarm function has two output settings, namely output A and output B.

Alarms can be acknowledged in one of two ways: Either the binary input "alarm ack." (selectable to be one of the binary inputs 10, 11, 12, 13, 14 and 15) is used, if this is configured for alarm acknowledge, or the select button on the display is used:

- The alarm acknowledge input acknowledges all present alarms, and the alarm LED will change from flashing to steady light.
- The display can be used in the alarm information window. The alarm information window displays one alarm at a time and the alarm state whether the alarm is acknowledged or not. If it is unacknowledged, then press  to acknowledge it. Use the  and  push-buttons to scroll in the alarm list.
- Shortcut to Alarm list: press and hold 

The alarm LED will be flashing, if unacknowledged alarms are present. The alarm relay will deactivate, when the alarm situation is reset and the alarm is acknowledged.

Timer function

The delay settings are all of the definite time type, i.e. a set point and time is selected.

If the function is e.g. overspeed, the timer will be activated, if the set point is exceeded. If the RPM value goes below the set point value before the timer runs out, then the timer will be stopped and reset.

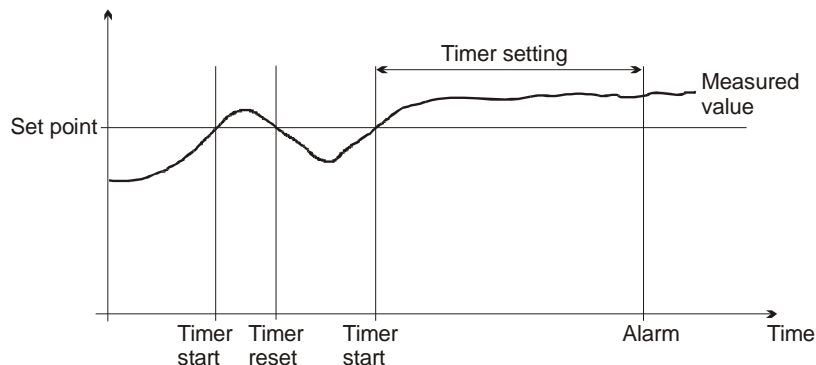

When the timer runs out and the alarm is present, the output is activated.

Mains voltage unbalance detection

The formula for mains voltage unbalance is:

$$(Most\ deviating\ line-to-line\ voltage - average\ voltage) * 100 / average\ voltage \quad (nominal\ value\ in\ \%)$$

Phase sequence error

Prior to closing a breaker the unit checks that the phase sequence is correct, depending on the chosen phase direction in parameter 2280: "phase rotation". If it's incorrect (reversed), an alarm will be issued and the breaker in question (generator or option A mains breaker) will not be closed and the breaker's LED will flash red.

TPS 300 software input configuration

It is possible to configure the inputs indicated in the table. The unit has a number of passive binary inputs (input terminals 10-15).

Input function	Comment
Test run	Configurable
Nom. setting 3 1 ph	Configurable
Alarm acknowledge	Configurable
Parameter shift (secondary parameters)	Configurable
Start enable (OFF = start blocked)	Configurable
GB Pos on	Configurable
GB Pos off	Configurable
MB Pos on	Configurable (option A)
MB Pos off	Configurable (option A)
Access lock	Configurable
Mode shift (auto/manual)	Configurable
Fire pump	Configurable
Remote start/stop	Configurable
D+	Configurable
Digital inputs no. 1....6 used as alarms	Configurable
Idle speed	Configurable
Inhibit EI alarms	Configurable (option J)

Input function description

1. Test run

When the test input is activated, the selected test sequence will start. Please see the test function description for further information.

2. Nom. setting 3 1 ph

Activates the third set of nominal settings, if the parameter 6026 is set to binary input. When deactivated, the MEC 310 returns to Nom. setting 1.

3. Alarm acknowledge

Acknowledges all present alarms.

4. Parameter shift

Selection of this input will make the unit use the secondary set of parameters (SP2).

5. Start enable

This input must be activated to start the engine.



Start enable is start control only, i.e. if removed when the engine is running, the engine keeps on running.

6. GB Pos on

When this input is activated, the MEC 310 sees the generator breaker as closed. If the GB on and the off feedback are on or off simultaneously, a GB position failure is displayed.

7. GB Pos off

When this input is activated, the MEC 310 sees the generator breaker as open. If the GB on and the off feedback are on or off simultaneously, a GB position failure is displayed.

8. MB Pos on

When this input is activated, the MEC 310 sees the mains breaker as open. If the MB on and the off feedback are on or off simultaneously, an MB position failure is displayed.

9. MB Pos off

When this input is activated, the MEC 310 sees the mains breaker as open. If the MB on and the off feedback are on or off simultaneously, an MB position failure is displayed.

10. Access lock

Activating the access lock input deactivates the control push-buttons on the display. It will only be possible to view measurements, alarms and the log.

11. Mode shift

Selection between manual and auto running. The mode is changed every time the input is activated (pulse input).

12. Fire pump (shutdown override)

Deactivates all protection functions except overspeed and emergency stop protection.

13. Remote start/stop input

Activating this input will start the gen-set. Deactivating it will stop the gen-set after cool down (auto mode only).

14. D+ (digital running feedback)

This input is used as a running indication of the engine. When the input is activated, the start relay is deactivated. Input for running feedback from charge generator +D terminal. (Runs when charger U > battery voltage).

15. Digital inputs 1...6

These inputs are configurable as alarm inputs.

16. Idle speed

Activating the idle speed input holds the engine at idle speed for as long as it is set.

17. Inhibit EI alarms

When this input is active, it will inhibit all engine interface (option J) alarms.



If nominal setting is going to be selected by a binary input, M-logic must be used.

Output functions

It is possible to configure the output functions indicated in the table. The unit has 7 configurable relay outputs (output terminals 20-27 and 45-48).

Input function	Factory setting
Run coil	Relay 23
Stop coil	
Prepare	Relay 21
Starter	Relay 22
Engine run indication	
Idle speed output	
Horn	Relay 24
Alarm/limit	Relay 26
Fuel pump	
Engine heater	
Stop coil (not acc in start seq.)	
Generator breaker	Relay 45
Mains Breaker	Relay 47



Relay 21/22/23/24/25/26 cannot be configured as MB or GB



Relay 47 is closed when de-energized, but works as all other relays when MEC 310 is powered up.

Output function description

1. Run coil

The relay configured to Run coil will be closed the entire time the engine is supposed to run.

2. Stop coil

This relay will close to stop the engine, and when no running feedback is present it will stay closed in the ext. stop time (parameter 6212).

3. Prepare

This function will close the relay as the first thing in the start sequence. The relay will be closed for the time programmed in parameter 6181. This function is used for preheating the engine or for prelubrication.

4. Starter

The relay configured to Starter will be closed for the time selected in parameter 6184 in the start sequence of the MEC 310.

5. Engine run indication

If a relay is configured to this function, this relay will close when a running feedback is detected. The relay will open again when the engine stops.

6. Idle speed output

This relay will close to give the engine governor the idle command (Low speed).

7. Horn

The horn relay is a common alarm output. This means that every time an alarm state appears the horn relay will close for the time configured in the parameter 6130 Alarm horn regardless of

fail class. If 6130 is set to 0 seconds, it will be on until the reset horn push-button is activated or the alarm(s) has (have) been acknowledged.

8. Alarm/limit

When this setting for the relay is selected, the relay can be used in the alarm parameters in the setting Output A and Output B. This means that with factory settings, the relay 2 can be used in the parameters as an alarm relay. If the relay is preferred to be a Limit relay, this selection must be done in the parameter list parameter 5000 to 5060.

9. Fuel pump

Output must be configured to use fuel pump settings.

10. Engine heater

The relay configured to Engine heater will close when the temperature is below the set point in parameter 6320 and open again when the temperature is above the set point in parameter 6330. For more information, see the description of the function.

11. Stop coil (not acc. in start seq.)

The relay configured to this function will do the same as the normal stop coil with one exception: It will not close between the start attempts.

After configuration of the input parameter, it is possible to assign an output. Use the dialogue box below for configuration of the output relay.

Remember to save and write the settings to the MEC 310 before closing the dialogue box.

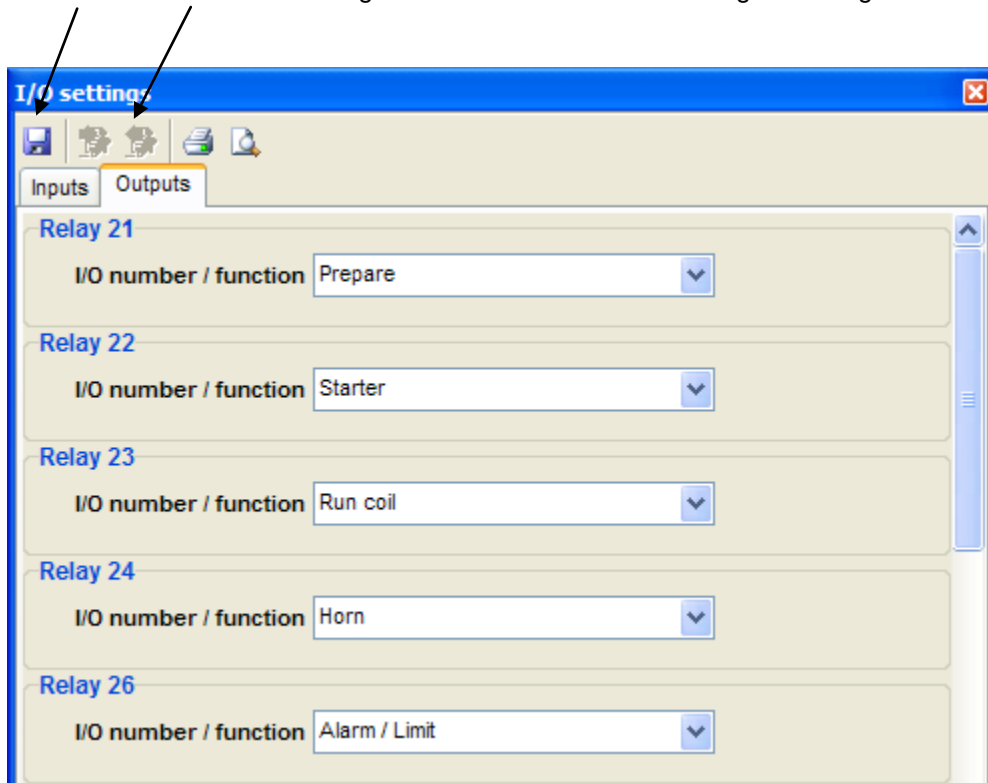

Configuration of the digital alarm inputs

The digital inputs are configured via the utility software (USW).

Use this button to upload the menu.

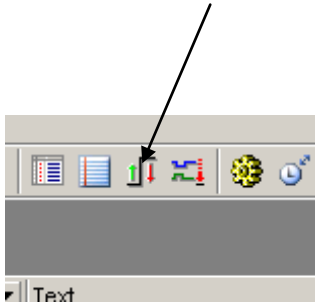

Remember to save and write the settings to the unit.

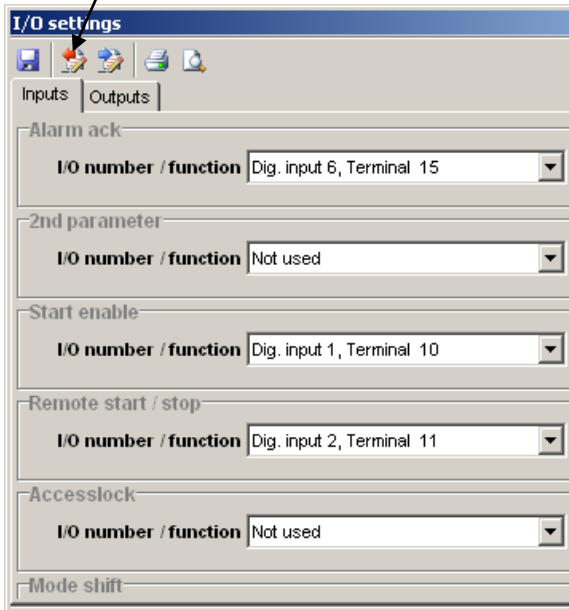

The individual I/O number and the function are now selected. In the example below 'Digital input 1' is chosen, and a terminal number must be assigned to the input. If the input is used as alarm input, then the name can be changed to the relevant name selected from the predefined list below.

3000-3050 Digital input term. 10-15, without wire break detection

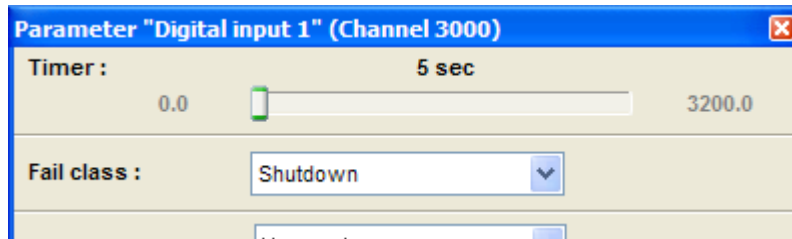

Renaming of the Digital input can be done in Translation.

Complete the input settings and select the appropriate fail class and outputs. The outputs A and B can be used to activate one or two of the configurable relay outputs or LEDs. If the relay function is set as a limit relay, no warning pop-up will be shown in the display. The relay 0 is a virtual relay, so both output A and B must be set to limit relays if no warning in the display is wanted.

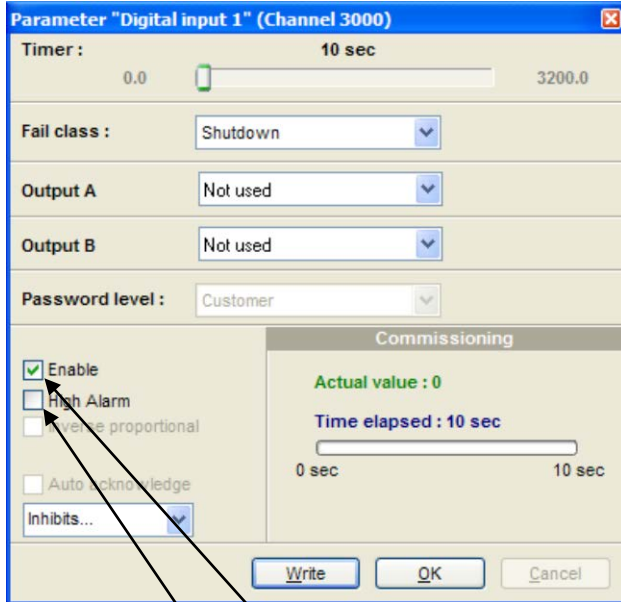

Remember to activate the function by marking the Enable tick box.

If the alarm is only to be active when the gen-set is running, the inhibit settings must be used. If etc "Not run status" is ticked in the inhibit settings, it means that the alarm is inhibited until the running feedback is present, when the Run status timer has not yet expired.

If the High Alarm is set, the alarm will be registered upon a closing contact. If the High Alarm is not set, the alarm will be registered upon an opening contact.

Configuration of common Alarm and Shutdown relay outputs

The versatility of the TPS 300 software permits the user to configure any output relay for available common Alarm or Common Shutdown relay output for the MEC 310 project. To properly configure a Common Alarm or Common Shutdown relay output you would need to perform the following steps:

NOTE: For this example Relay 45 will be used as a Common Shutdown and Relay 47 will be used as a Common Alarm.

1. In the I/O Settings window, set output relay 45 and relay 47 as Alarm/Limit.

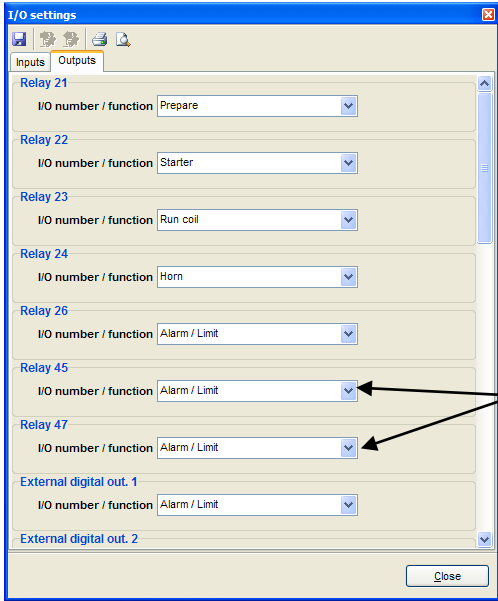

Remember to save and write the settings to the unit.

2. In the Outputs category of the Parameters tab, set relay 45 and relay 47 as Limit.

In the TPS300 Software, click on the Parameters tab found on the left hand side.

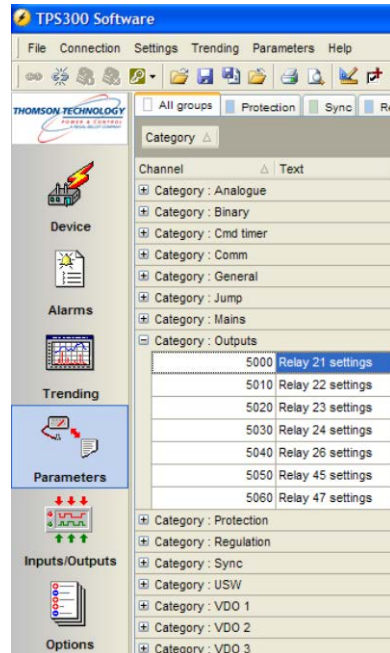
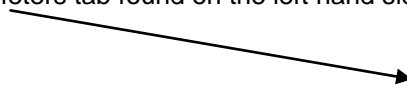

Double-click on relay 45 and relay 47 to open up the settings window. From the dropdown list found in the Setpoint section select 'Limit function'.

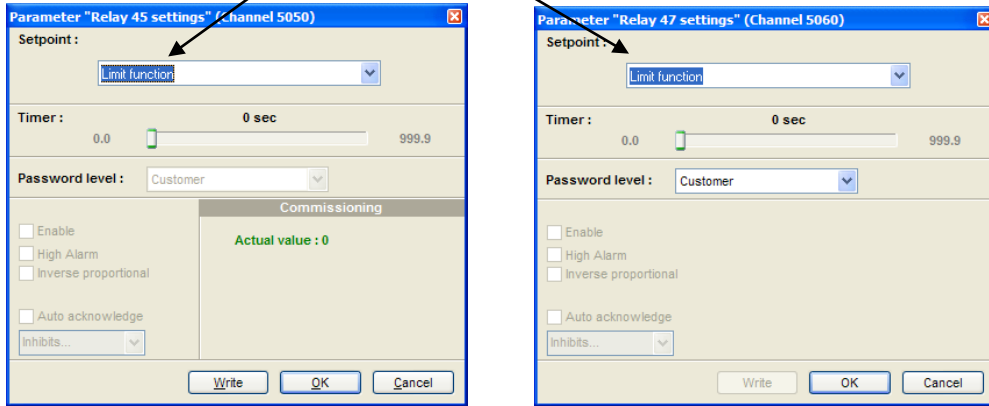

Remember to write the settings to the unit.

- Under the M-Logic tab, the user will need to setup a Logic rung for Common Warning and a Logic rung for Common Shutdown. Have each Logic rung tied to the appropriate output relay.

In the TPS300 Software, click on the Parameters tab found on the left hand side.

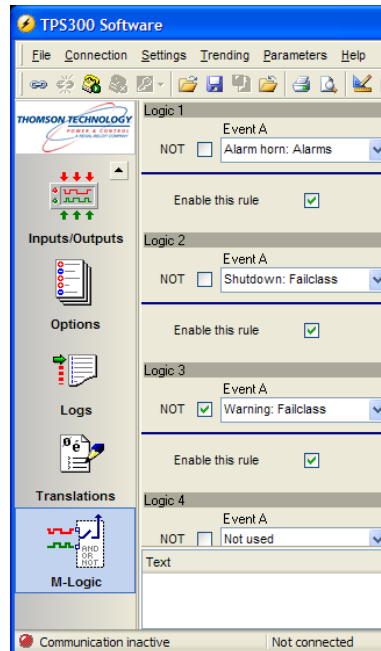

Setup a Logic rung with the following information for Relay 45 - Common Shutdown:

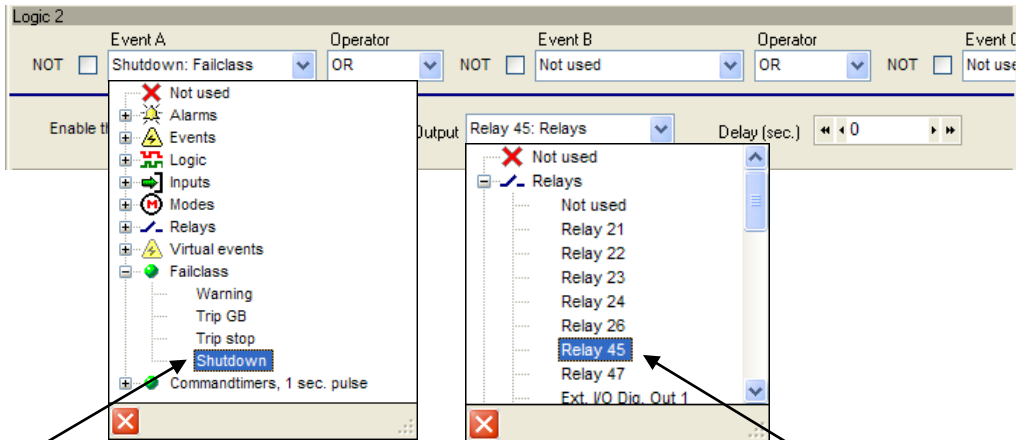

From the dropdown list for Event A - Select **Shutdown**

From the dropdown list for Output- Select **Relay 45**

- NOT –
- Event A – ‘Shutdown: Failclass’
- Output – ‘Relay 45: Relays’
- Enable this rule –

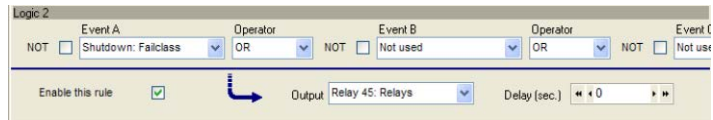

Setup a Logic rung with the following information for Relay 47 - Common Alarm:

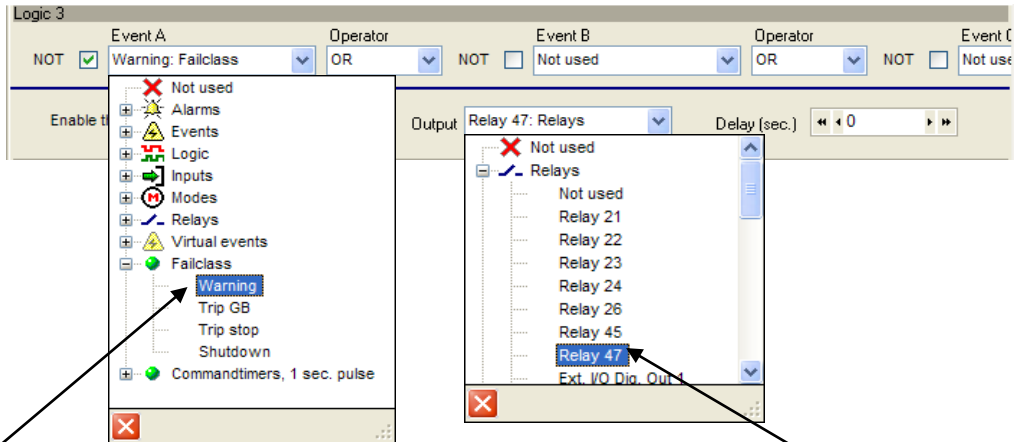

From the dropdown list for Event A - Select **Warning**

From the dropdown list for Output- Select **Relay 47**

- NOT –
- Event A – ‘Warning: Failclass’
- Output – ‘Relay 47: Relays’
- Enable this rule –

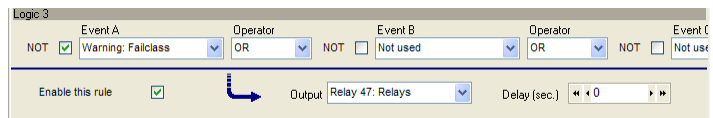

Relay 47 has a N/C (normally closed) contact, selecting NOT will invert the contact state. Remember to save and write the settings to the unit.

- Under the Parameters tab of the TPS300 Software the user will need to setup all of the required Channels that will need to be associated to the Common Alarm or Common Shutdown relays.

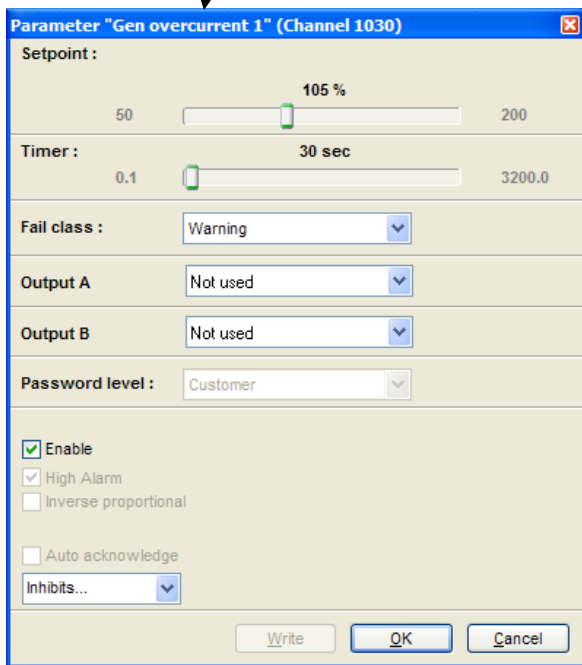
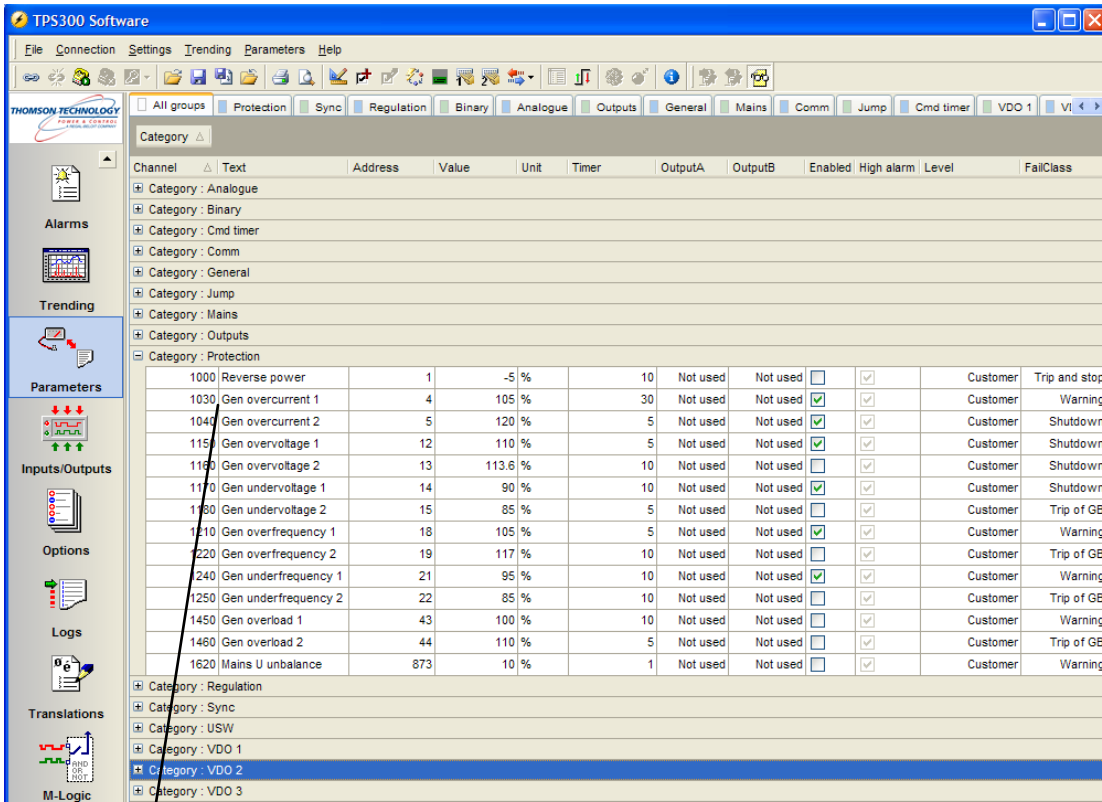

Example Parameter Settings:

- Setup parameter with required 'Setpoints' and 'Timer' values.
- Set 'Fail class' to WARNING or SHUTDOWN.
- Leave 'Output A' and 'Output B' to NOT USED.
- ENABLE to parameter settings.

Alarm inhibit

In order to select when the alarms are to be active, a configurable inhibit setting for every alarm has been made. The inhibit functionality is only available via the PC utility software. For every alarm there is a drop-down window where it is possible to select which signals that have to be present in order to inhibit the alarm.

In this example, inhibit is set to Not run status. Here, the alarm will only be active when the generator has started and running feedback is present.

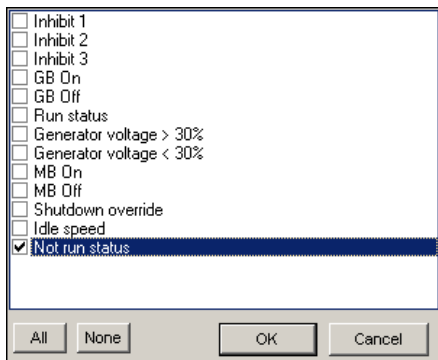
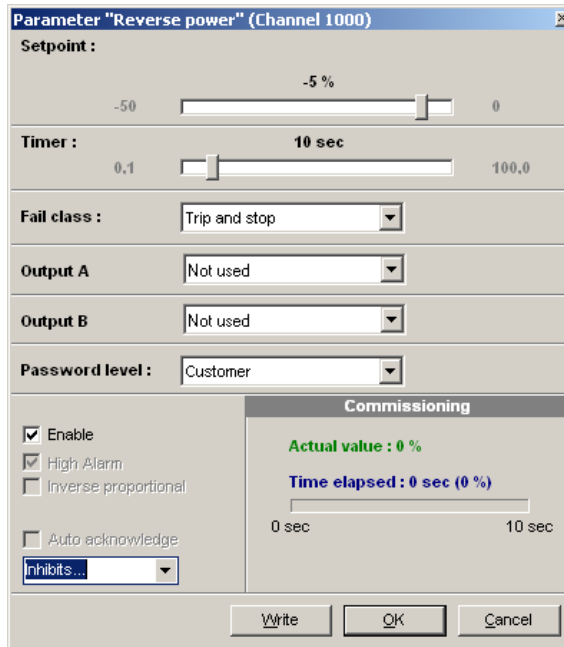

Function	Description
Inhibit 1	M-logic outputs: Conditions are programmed in M-logic
Inhibit 2	
Inhibit 3	
GB ON (TB ON)	The generator breaker is closed
GB OFF (TB ON)	The generator breaker is open
Run status	Running detected and the timer in menu 6160 expired
Not run status	Running not detected or the timer in menu 6160 not expired
Generator voltage > 30%	Generator voltage is above 30% of nominal
Generator voltage < 30%	Generator voltage is below 30% of nominal
MB ON	The mains breaker is closed
MB OFF	The mains breaker is open
Idle speed	Idle speed depends of the engine manufacture
Shutdown override	Inhibit if Shutdown override input is active



If an alarm is configured to activate a limit relay, the relay will activate despite the fact that the inhibit input is ON.

Configuration of the External I/O

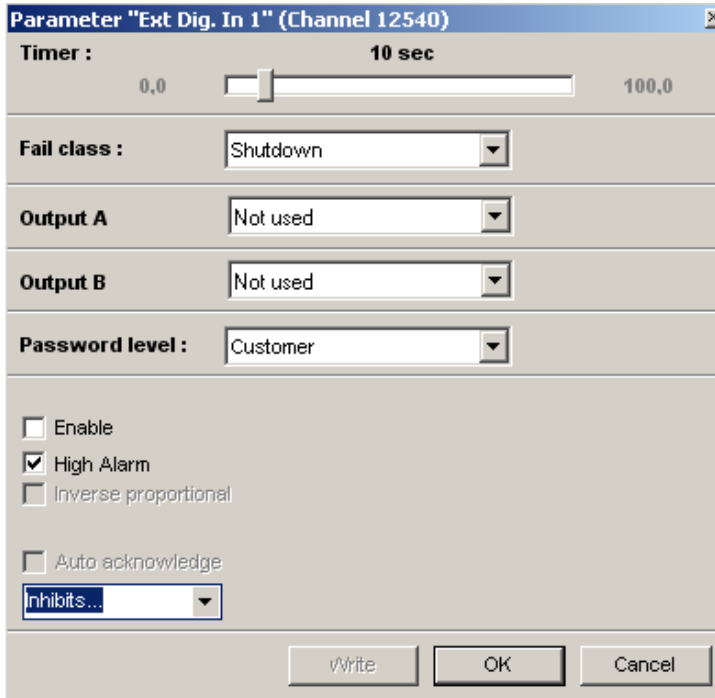

External I/O's have the same popup window with parameter settings as the internal I/O's in MEC 310.

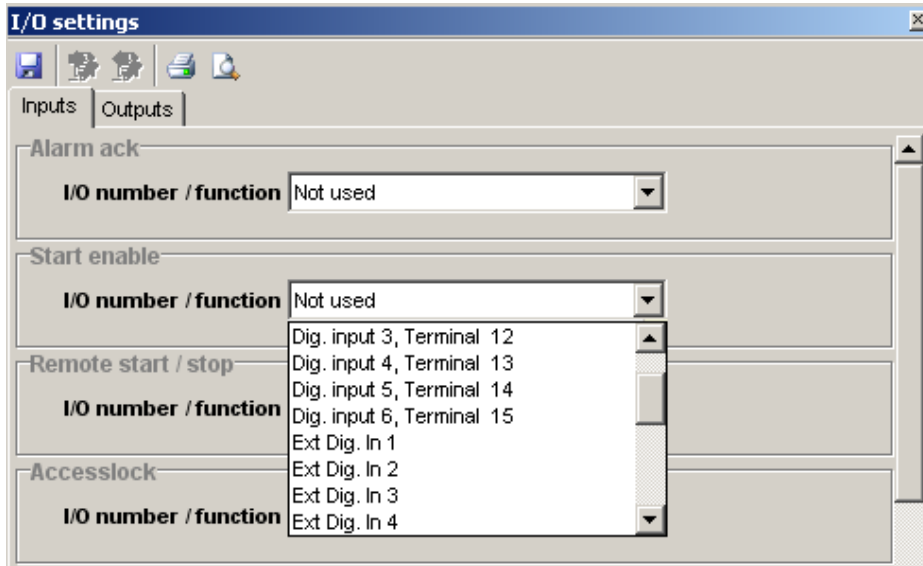

Programming of external I/O's are done the same way as the inbuilt I/O's in MEC 310. Using TPS 300 software.

Input status		Output status	
<input type="radio"/> Emergency stop	<input type="radio"/> Ext Dig. In 12	<input type="radio"/> Prepare relay	<input type="radio"/> Ext Dig. Out 12
<input type="radio"/> Not used	<input type="radio"/> Ext Dig. In 13	<input type="radio"/> Starter	<input type="radio"/> Ext Dig. Out 13
<input type="radio"/> Remote start / stop	<input type="radio"/> Ext Dig. In 14	<input checked="" type="radio"/> Run coil	<input type="radio"/> Ext Dig. Out 14
<input type="radio"/> D+	<input type="radio"/> Ext Dig. In 15	<input type="radio"/> Horn	<input type="radio"/> Ext Dig. Out 15
<input type="radio"/> Digital input 1	<input type="radio"/> Ext Dig. In 16	<input type="radio"/> Alarm	<input type="radio"/> Ext Dig. Out 16
<input type="radio"/> Digital input 2		<input type="radio"/> Mains breaker	
<input type="radio"/> Digital input 3		<input type="radio"/> Generator breaker	
<input type="radio"/> Ext Dig. In 1		<input type="radio"/> Ext Dig. Out 1	
<input type="radio"/> Ext Dig. In 2		<input type="radio"/> Ext Dig. Out 2	
<input type="radio"/> Ext Dig. In 3		<input type="radio"/> Ext Dig. Out 3	
<input type="radio"/> Ext Dig. In 4		<input type="radio"/> Ext Dig. Out 4	
<input type="radio"/> Ext Dig. In 5		<input type="radio"/> Ext Dig. Out 5	
<input type="radio"/> Ext Dig. In 6		<input type="radio"/> Ext Dig. Out 6	
<input type="radio"/> Ext Dig. In 7		<input type="radio"/> Ext Dig. Out 7	
<input type="radio"/> Ext Dig. In 8		<input type="radio"/> Ext Dig. Out 8	
<input type="radio"/> Ext Dig. In 9		<input type="radio"/> Ext Dig. Out 9	
<input type="radio"/> Ext Dig. In 10		<input type="radio"/> Ext Dig. Out 10	
<input type="radio"/> Ext Dig. In 11		<input type="radio"/> Ext Dig. Out 11	

Legend : ? State undetermined State low State high

Refresh I/O texts

Only available external I/O's are listed in Input/Output view. If e.g. one hardware module is removed, it will also be removed from the list above.



Remember to press “Refresh I/O texts” button after any changes made.

Alarm indication LEDs

Alarm indication LEDs are the 4 LEDs placed in the right side of the front label on the MEC 310. In the clear window next to the LEDs a label can be placed to explain the function of the LEDs. No label is provided from the factory. The label can be written on an overhead projector sheet and can be used with the print template on the cd-rom.

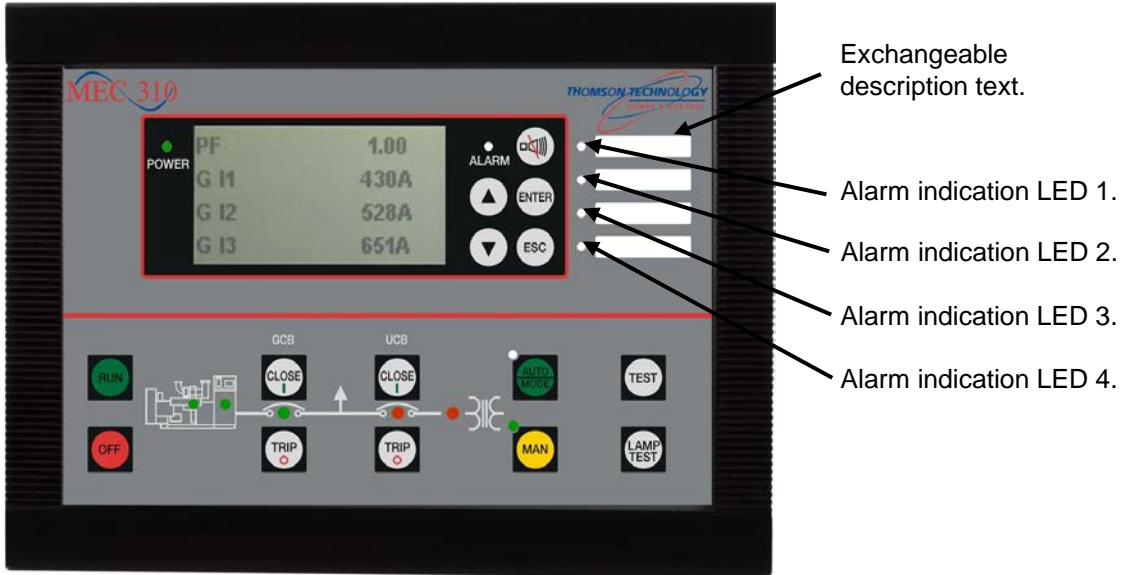

Configuration of the alarm indication LEDs

The alarm indication is able to indicate alarm status on one single alarm or a group of alarms. The factory setting for the LEDs is not used. When an alarm appears where one of the LEDs is set in output A or B, the LED will start flashing red. When the alarm is acknowledged, the LED will turn to steady red light. When the alarm status is no longer present, the LED will be turned off.

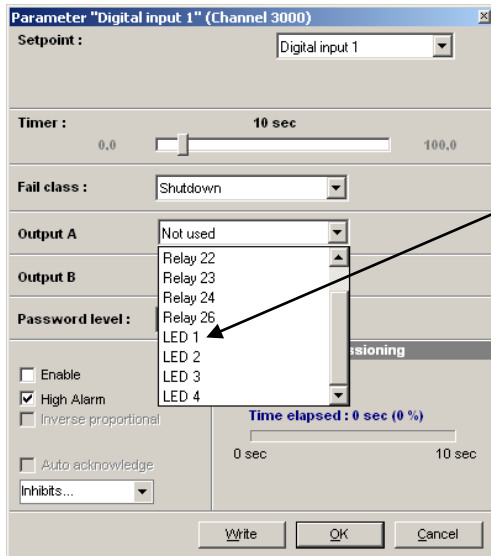

Here the alarm LED indication can be selected.

Parameter groups

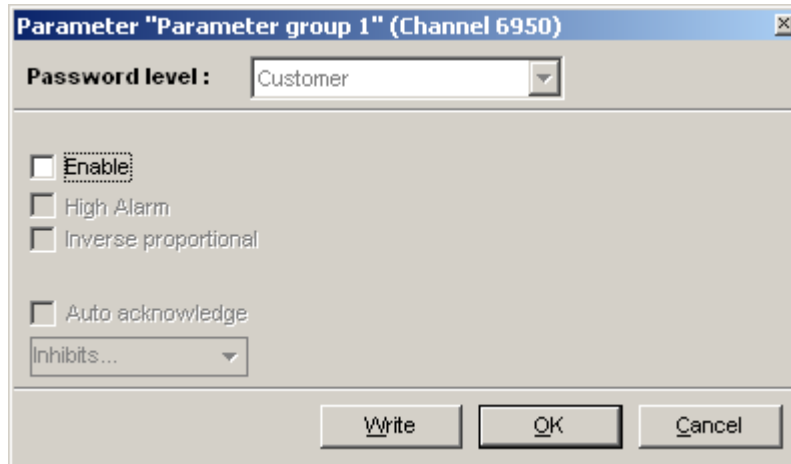

Parameters shown in the display are split up in a default parameter list and the rest into three groups. It's possible to select one or two of the groups or select them all.

Language selection

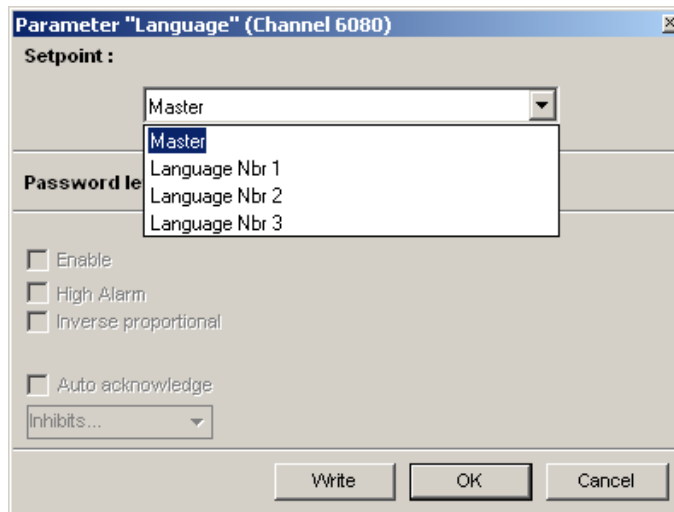

The unit has the possibility to display different languages. It is delivered with one master language which is English, furthermore three languages which are selected by the customer on the order specification. One or all of the three languages can be changed to a customised language made by the customer in translation in the TPS 300 software. The used language can be changed when connected to the TPS 300 software. It is not possible to make language configuration from the display, but the already configured languages can be selected.

Translation

Translation gives the customer the possibility to translate all texts that are shown in the display. Parameter texts used in the PC USW will only be shown in master language.

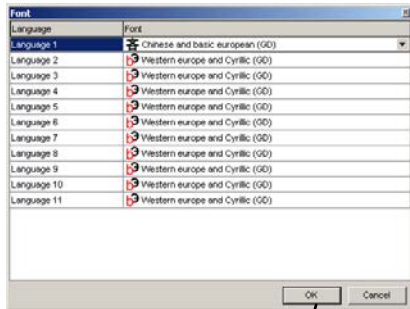

Setup for characters

Icons used for upload/download of translation. Sync icon used to synchronise between master language and customised language files done by customer.

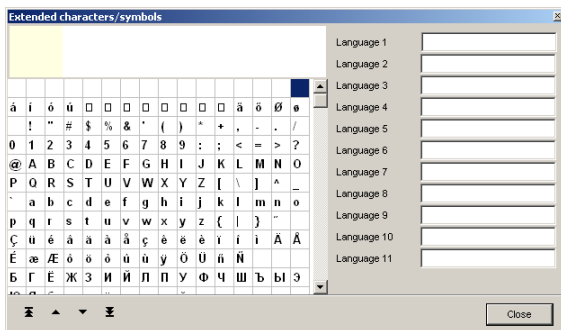
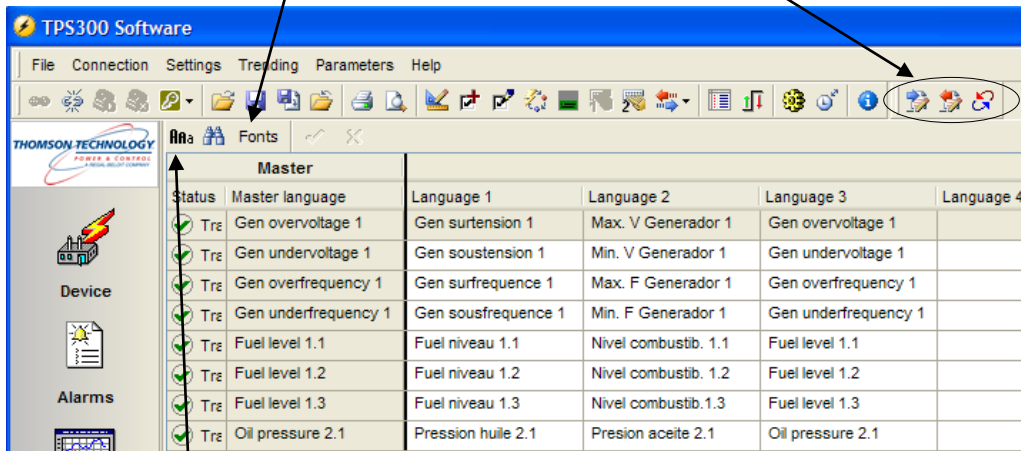

Extended characters/symbols



Characters not supported by MEC 310 will give a question mark in the text field.

Fail class

All the activated alarms of the MEC 310 must be configured with a fail class. The fail classes define the category of the alarms and the subsequent action of the alarm.

Four different fail classes are available:

Fail class	Action						
	Alarm horn relay*	Alarm display	Block engine start	Open gen. breaker	Stop generator	Cooldown	Shutdown
0 Warning	X	X					
1 Trip of GB	X	X		X			
2 Trip and stop	X	X	x	X	X	X	
3 Shutdown	X	X	x	X	X		X

* When alarm horn relay output is selected active.

Fail class configuration

The fail class can be selected for each alarm function via the TPS 300 software. To change the fail class via the TPS 300 software, the alarm function to be configured must be selected. Select the desired fail class in the fail class roll down panel.

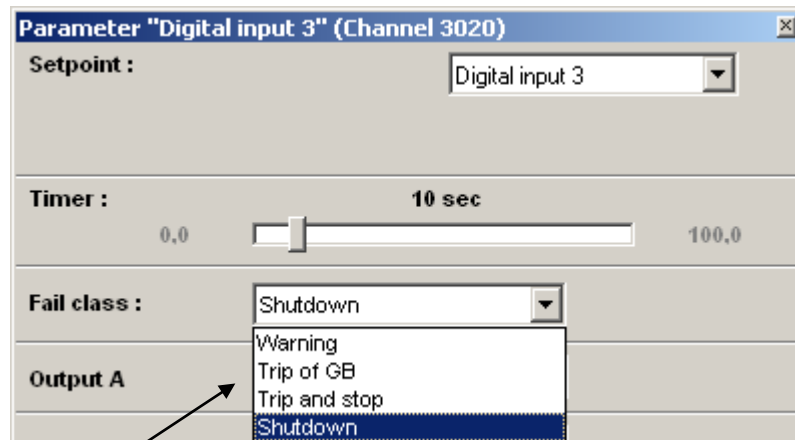

The fail class roll down panel is activated, and the individual functions are ready for selection.

Service timers

Parameter "Servicetimer 1" (Channel 6111)

Setpoint :

Counting up

Service timer off

Password level

Counting up

Counting down

Enable

High Alarm



Inverse proportional

Auto acknowledge

Inhibits...

Write OK Cancel

The controller can monitor two different maintenance intervals:

-  Service timer 1
-  Service timer 2

The service timers both have the possibility of a setting for days (total elapsed time) and hours (running hours). The day setting counts whenever there is aux. supply on the MEC 310, and the hours count when a running feedback is present. It is possible to set the service timers to count up or count down.

The service timer alarm activates whenever the amount of days or the amount of running hours has expired. If the service timer is set to count down the display will show 0 days or 0 hours; if the service timer is set to count up the display will show the amount of days or hours programmed in the parameter.

When the service timer alarm appears it can be acknowledged but the alarm will not become inactive before the service timer has been reset. This can be done from the display or via the TPS 300 software. Whenever the service timer is reset, the timer will start counting from the initial value.



The service timer alarm must be reset in the parameter list of the MEC 310 or via the TPS 300 software in parameter 6116 or 6126 to remove the actual alarm.

Counters

Counters for various values are included, and some of these can be adjusted if necessary, for instance if the unit is installed on an existing gen-set or a new circuit breaker has been installed. The table shows the adjustable values and their function in menu 6100: Description Function Comment.

Description	Function	Comment
6101 Running time	Offset adjustment of the total running hours counter.	Counting when the running feedback is present.
6103 GB operations	Offset adjustment of the number of generator breaker operations.	Counting at each GB close command.
6105 kWh reset	Resets the kWh counter.	Automatically resets to OFF after the reset. The reset function cannot be left active.



The service timer alarm must be reset in the parameter list via the MEC 310 display or via the utility software in parameter 6116 or 6126 to remove the actual alarm.

Command timer

The purpose of command timer is to be able to start and stop the gen-set automatically at specific times each weekday or certain weekdays. Up to 8 commands can be used for either start or stop. The settings are set up through the TPS 300 software. Each command can be set for the following time periods:

- Individual days (MO, TU, WE, TH, FR, SA, SU)
- MO, TU, WE, TH
- MO, TU, WE, TH, FR
- MO, TU, WE, TH, FR, SA, SU
- SA, SU

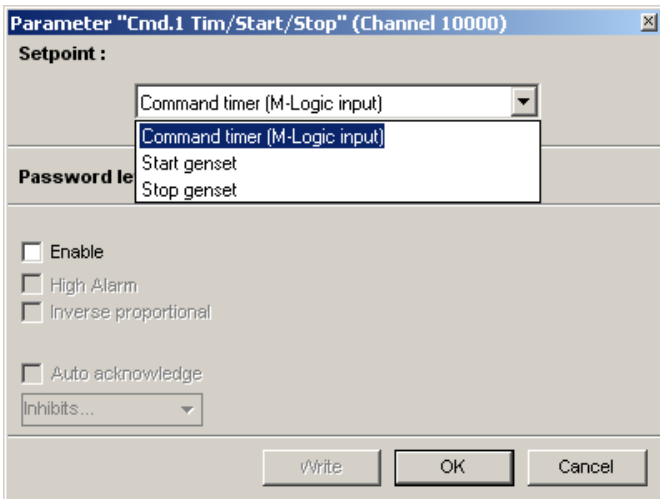

Select command timer function

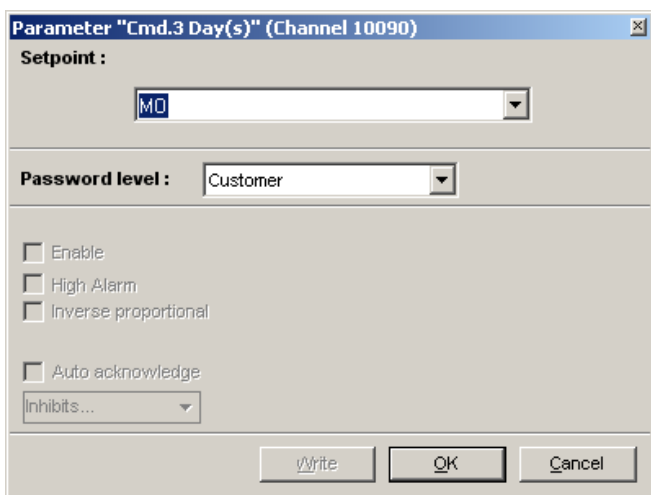

Select day(s) command timer should be active

Hour setting

Minute setting



The digital input 'auto start/stop' cannot be used, when this function is enabled.



It is necessary to use the TPS 300 software when setting up command timers (settings 10000 to 10310).

Configurable views in the display

The views in the display are configurable; this gives the customer the opportunity to make their own views. There are up to 15 configurable views, which can all be set to 3 or 4 line views.

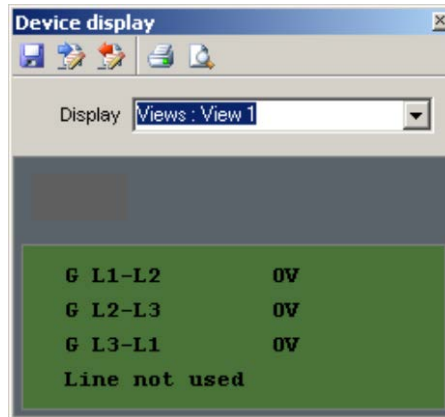

Possible views		
Text in USW	View in display	Comment
G L1-L2	G L1-L2 XXX V	
G L2-L3	G L2-L3 XXX V	
G L3-L1	G L3-L1 XXX V	
G L1-N	G L1-N XXX V	
G L2-N	G L2-N XXX V	
G L3-N	G L3-N XXX V	
G I L1	G I L1 XXX A	
G I L2	G I L2 XXX A	
G I L3	G I L3 XXX A	
G P L1	G P L1 XXX kW	
G P L2	G P L2 XXX kW	
G P L3	G P L3 XXX kW	
G f L1	G f L1 XX.X Hz	
G L1 L2 L3	G L1 L2 L3	Only in 4 line view
G UL1 UL2 UL3	XXXX XXXX XXXX Vpn	Only in 4 line view
G UL12 UL23 UL32	XXXX XXXX XXXX Vpp	Only in 4 line view
G IL1 IL2 IL3	XXXX XXXX XXXX A	Only in 4 line view
G PL1 PL2 PL3	XXXX XXXX XXXX kW	Only in 4 line view
PF	PF X.XX	The unit can be either I or C for Inductive or Capacitive
P	P XXX kW	
Q	Q XXX kVAr	
S	S XXX kVA	
E	E XXX kWh	
M L1-L2	M L1-L2 XXX V	
M L2-L3	M L2-L3 XXX V	
M L3-L1	M L3-L1 XXX V	
M L1-N	M L1-N XXX V	

MEC 310 GENSET CONTROLLER

M L2-N	M L2-N	XXX V	
M L3-N	M L3-N	XXX V	
M L1 L2 L3	M L1 L2 L3		Only in 4 line view
M UL1 UL2 UL3	XXXX XXXX XXXX Vpn		Only in 4 line view
M UL12 UL23 UL32	XXXX XXXX XXXX Vpp		Only in 4 line view
Multi-input 1	Fuel level	XXX %	
Multi-input 2	Oil press	XX.Xbar	
Multi-input 3	Water Temp	XX °C	
Run hours	Run hours	XXXXXh	
Fire pump hours	Fire pump	XXXXXh	Counting when running feedback OK and shutdown override input is active
Battery	Battery	XX.XV	
RPM	RPM	XXXX	
Time and date	10/01 2008	hh:mm:ss	
Service 1	Service 1	0d 0 h	
Service 2	Service 2	41d 16h	
Empty line			To make a view nice
EIC speed	RPM		
EIC T. Coolant	EIC T. Coolant		
EIC L. Coolant	EIC L. Coolant		
EIC P. Coolant	EIC P. Coolant		
EIC T. Oil	EIC T. Oil		
EIC L. Oil	EIC L. Oil		
EIC P. Oil	EIC P. Oil		
EIC T. Fuel	EIC T. Fuel		
EIC P. Fuel	EIC P. Fuel		
EIC T. Air Inl.	EIC T. Air Inl.		
EIC P. Air Inl.	EIC P. Air Inl.		
EIC P. Boost	EIC P. Boost		
EIC Faults	EIC Faults		
EIC Fuel Rate	EIC Fuel Rate		
EIC P. Charge Air	EIC P. Charge Air		
EIC T. Charge Air	EIC T. Charge Air		
EIC DDETorque	EIC DDETorque		
EIC ACTorque	EIC ACTorque		
EIC PosAcc	EIC PosAcc		
EIC Load speed	EIC Load speed		
EIC T. Ex. Gas	EIC T. Ex. Gas		
EIC engine run hours	EIC engine run hours		
EIC P. Fi. Oil	EIC P. Fi. Oil		
EIC Battery	EIC Battery		
EIC P. Crank	EIC P. Crank		
EIC Water In Fuel	EIC Water In Fuel		
EIC Blowby Flow	EIC Blowby Flow		
EIC P. Fuel R.	EIC P. Fuel R.		
EIC P. Timing	EIC P. Timing		
EIC T. Afterc. W.	EIC T. Afterc. W.		
EIC T. Turbo Oil	EIC T. Turbo Oil		
EIC P. Trap Inlet	EIC P. Trap Inlet		
EIC P. Air in diff	EIC P. Air in diff		

EIC P. Cool diff	EIC P. Cool diff	
EIC P. Barometric	EIC P. Barometric	
EIC T. Ambient Air	EIC T. Ambient Air	
EIC T. Exh. Right	EIC T. Exh. Right	
EIC T. Exh. Left	EIC T. Exh. Left	
EIC T. Winding 1	EIC T. Winding 1	
EIC T. Winding 2	EIC T. Winding 2	
EIC T. Winding 3	EIC T. Winding 3	
EIC P. Aux 1	EIC P. Aux 1	
EIC P. Aux 2	EIC P. Aux 2	
EIC T. Turbo	EIC T. Turbo	
EIC T. Intercooler	EIC T. Intercooler	

Factory default views:

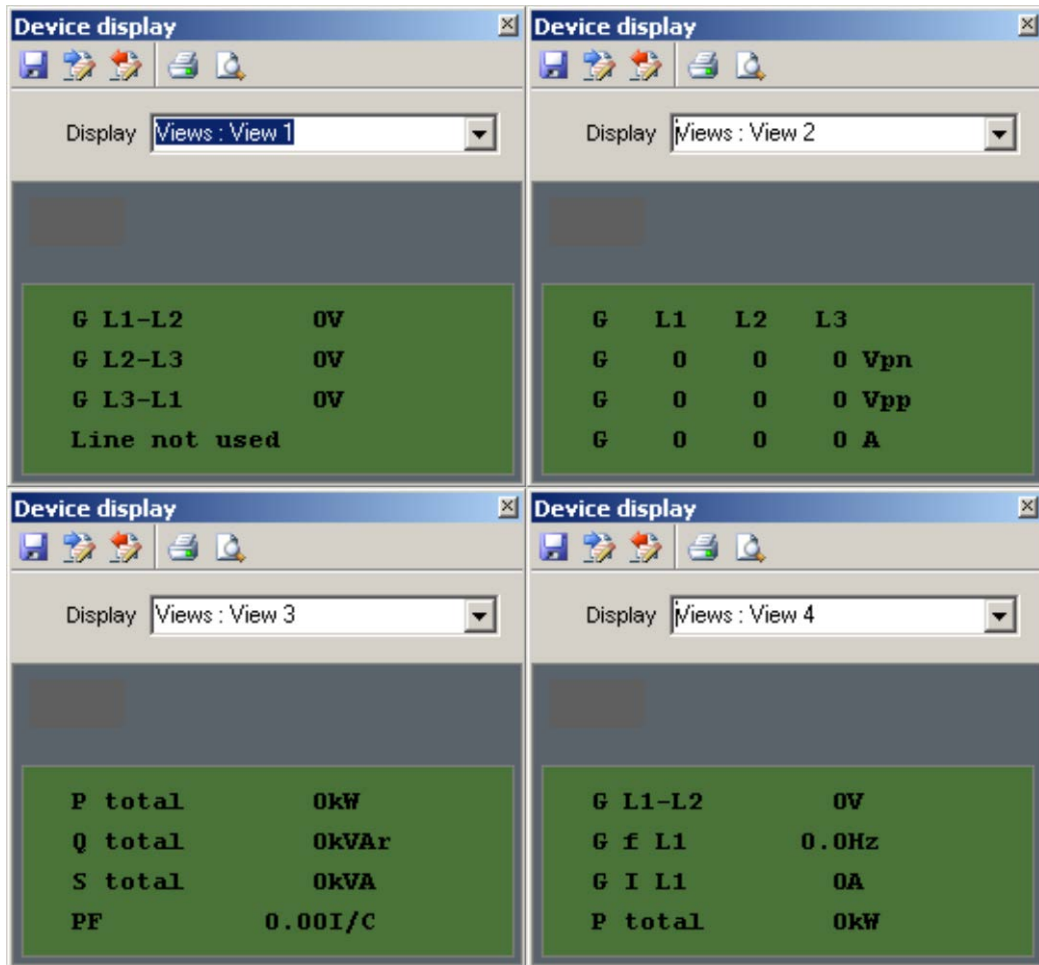

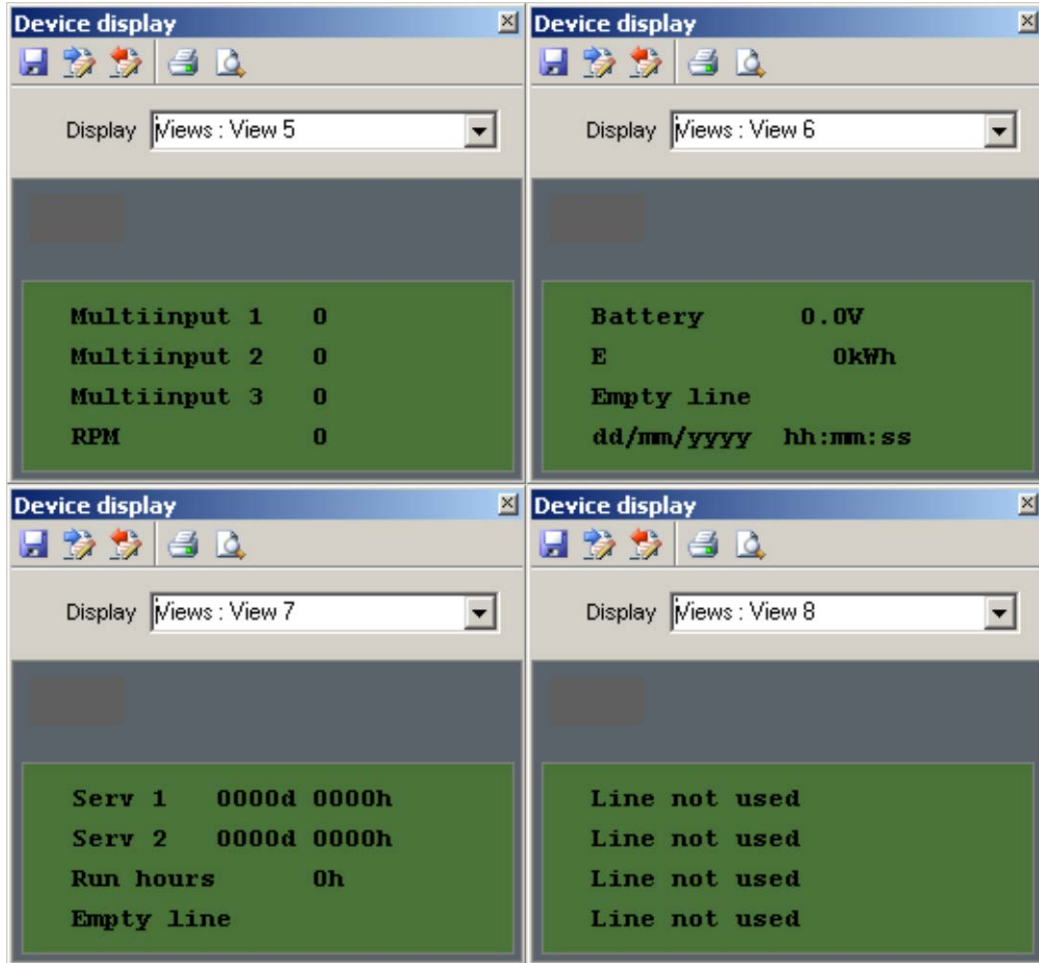

8-15 display views are empty

VDO sensors



In the following description of the VDO inputs the order will be input 2, 3, 1. In this way we are using the same order as in the TPS 300 software.



VDO sensors are noise sensitive; therefore we recommend using 2 wire sensors.

There are three VDO inputs in the unit. The inputs have different functions due to the fact that the hardware design is able to cover several VDO types.



All VDO inputs have a general accuracy of 2%.

- VDO input 1: Fuel level sensor - max. 180 Ohm
- VDO input 2: Oil pressure - max. 240 Ohm
- VDO input 3: Cooling water temperature - max. 2500 Ohm

VDO input 1, fuel level

VDO sensor type	
Type 1	
Value	Resistance
0%	78.8Ω
100%	1.6Ω

VDO sensor type	
Type 2	
Value	Resistance
0%	3Ω
100%	180Ω



VDO input 1, fuel level: type 1 and 2 curves are linear.

VDO sensor type	
Type 3	
Value	Resistance
%	Configurable
0	
10	
20	
30	
40	
50	
60	
70	
80	
90	
100	



Type 3 is fully configurable with 8 points in the input range 0-180Ω and 0-100%.

The TSP 300 software setting looks like this:

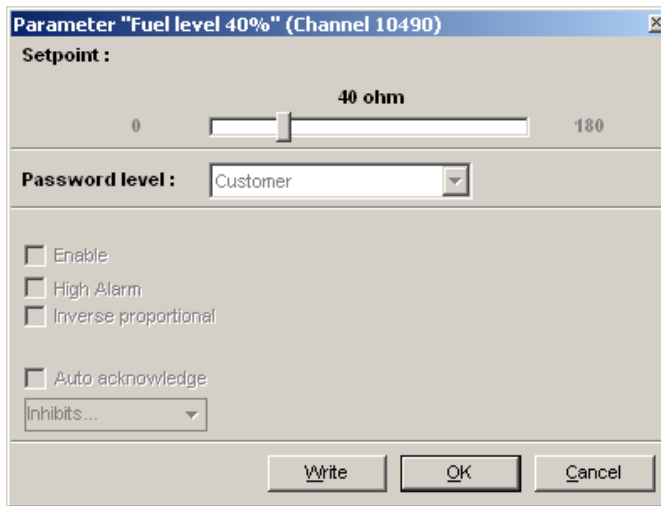

 8 settings are available from 0-150%.

VDO input 2, oil pressure

Pressure		VDO sensor type		
		Type 1	Type 2	Type 3
Bar	Psi	Ω	Ω	Ω
0	0	10.0	10.0	Configurable
0.5	7	27.2		
1.0	15	44.9		
1.5	22	62.9		
2.0	29	81.0	51.5	
2.5	36	99.2		
3.0	44	117.1	71.0	
3.5	51	134.7		
4.0	58	151.9	89.6	
4.5	65	168.3		
5.0	73	184.0	107.3	
6.0	87		124.3	
7.0	102			
8.0	116		155.7	
9.0	131			
10.0	145		184.0	

 Type 4 is fully configurable with 8 points in the range 0-240 Ω and 0-10.0 bar. The parameter settings can be found from menu 10810.

The TPS 300 software setting looks like this:

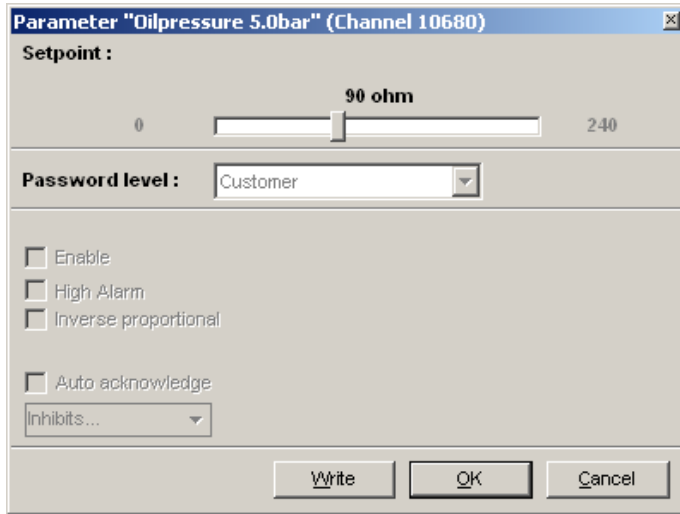

i 8 settings are available from 0-10 bar.

VDO input 3, cooling water temperature

		VDO sensor type			
Temperature		Type 1	Type 2	Type 3	Type 4
°C	°F	Ω	Ω	Ω	Ω
40	104	291.5	480.7	69.3	Configurable
50	122				
60	140	134.0	222.5	36.0	
70	158	97.1		27.9	
80	176	70.1	113.2	19.8	
90	184	51.2	83.2	15.8	
100	212	38.5	62.4	11.7	
110	230	29.1	47.6	9.5	
120	248	22.4		7.4	
130	266		28.9		
140	284				
150	302		18.2		

i Type 4 is fully configurable with 8 points in the range 0-2500Ω and 40-150°C or 104-302°F.

The TPS 300 software setting looks like this:

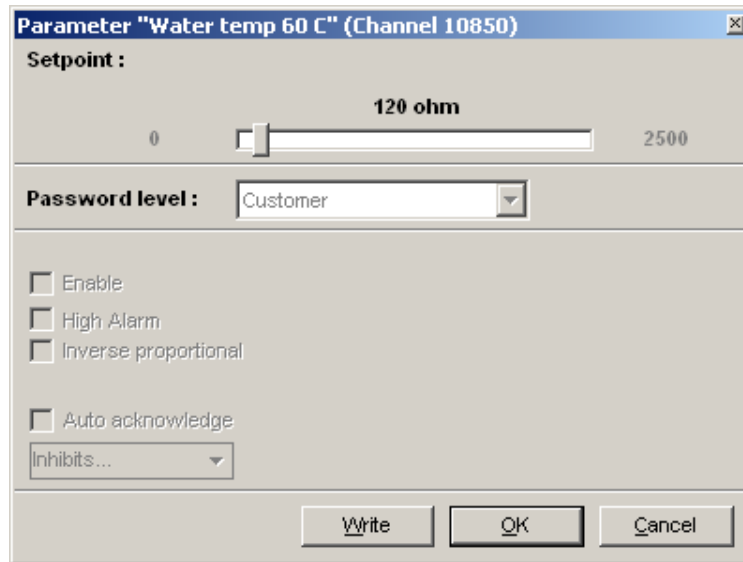

i 8 settings are available from 0-150° or 104-302°F.

VDO usage

The VDO inputs are used as alarm inputs and can be configured in the following menus.

VDO input 1: Fuel level - alarm settings in menus:

- 4230 VDO fuel level input 2.1
- 4240 VDO fuel level input 2.2

VDO input 2: Lubricating oil pressure - alarm settings in menus:

- 4310 VDO oil pressure input 2.1
- 4320 VDO oil pressure input 2.2

VDO input 3: Cooling water temperature - alarm settings in menus:

- 4460 VDO water temp input 3.1
- 4470 VDO water temp input 3.2
-

i In addition, VDO input 1 is also used for the fuel logic function.

Illustration of configurable inputs

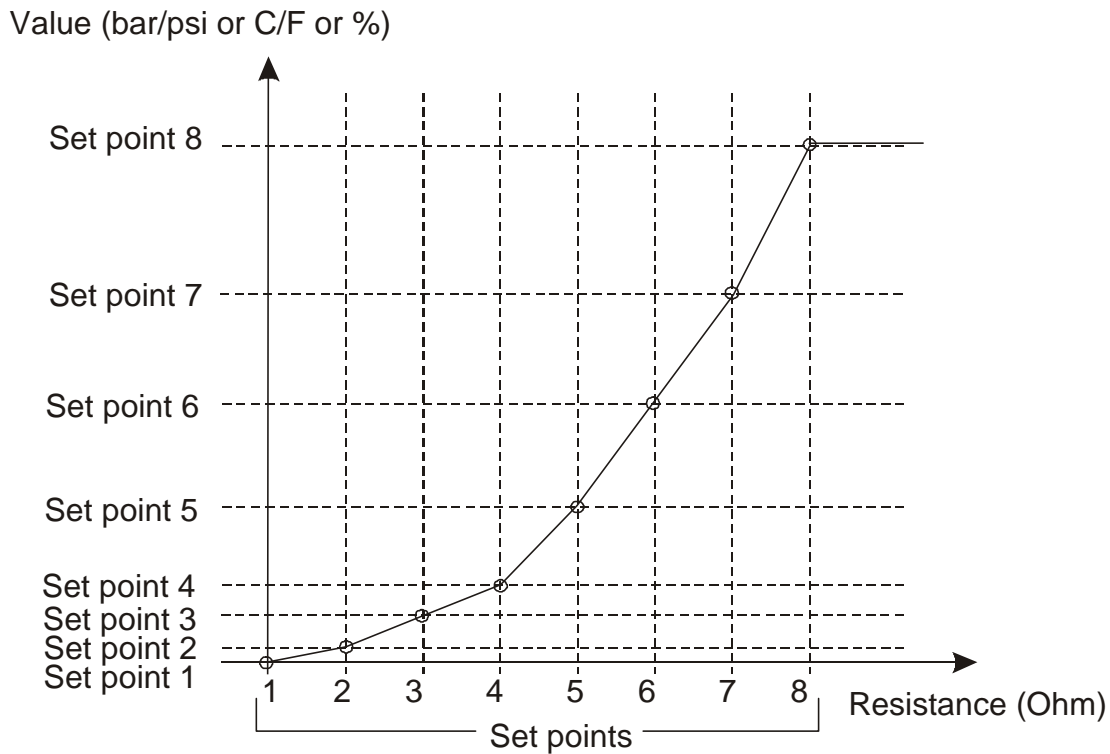

Configuration

The 8 curve settings for the configurable VDO inputs cannot be changed in the display, but **only** in the TPS 300 software.

Binary inputs with cable supervision

The binary inputs are based on the VDO inputs, i.e. if a VDO input is selected, the binary input cannot be chosen, and vice versa. When selected as multi-functional inputs, the 3 VDO inputs can be changed to binary inputs with cable supervision. The cable supervision is selectable (ON/OFF) and based on the VDO inputs using a 100 Ohm resistor across the monitored switch. The resulting function is:

- R < 20 Ohm = Switch closed
- 30 < R < 140 Ohm = Switch open, cable OK
- 150 Ohm < R = Wire break

The setting of the alarm input is carried out in the same way as the setting of the standard binary input. The texts can be changed in translation.

Fuel pump logic

The fuel pump logic is used in order to start and stop the fuel supply pump to maintain the fuel level in the service tank at predefined levels. The start and stop limits are detected from the VDO 1 input.

Start level, factory setting at 20% 6551

Stop level, factory setting at 80% 6552



The fuel pump relay is an NO relay and is configured to relay 2 by default. This configuration cannot be changed. If other alarm functions have been configured to relay 2, and the fuel logic is activated, then a *relay channel error* alarm will occur. Please make sure that relay 2 is configured to Fuel Pump.

- Start level, relay 2 activates
- Stop level, relay 2 deactivates

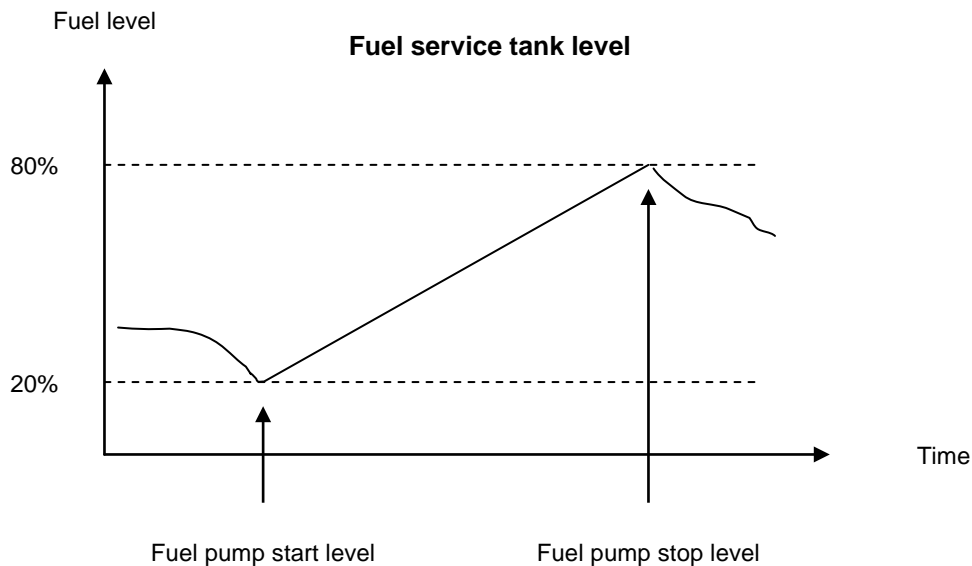

Fuel fill check

The fuel pump logic includes a *fuel fill check* function.

When the fuel pump is running, the fuel level must increase with 4% within the *fuel fill check* timer. This timer is adjusted in 6550 Fuel pump logic, but the level of increase cannot be changed. If the fuel level does not increase at least 4% within the adjusted delay time, then the fuel pump relay will deactivate, and a *fuel fill alarm* occurs.

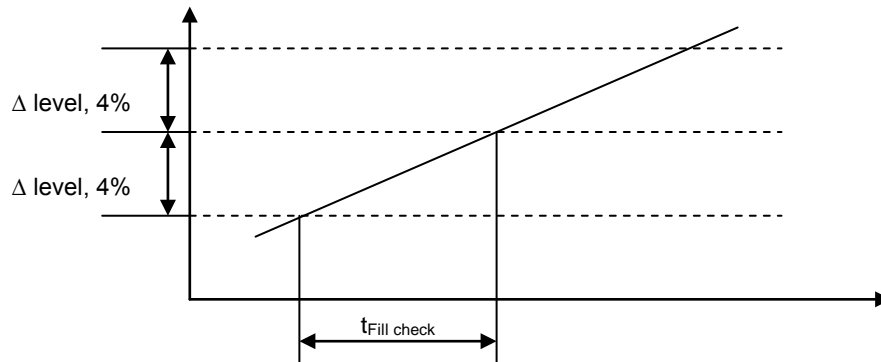

Emergency stop will also deactivate the fuel pump.

Analogue inputs 0(4)-20mA

The 0(4)-20mA setting can *only* be set in the TPS 300 software.
 4-20mA inputs have wire break detection. The wire break detection limit is 2.5mA.

Settings:

- Scale top point value (click the '...').
- Alarm setpoint: Freely configurable (click the '...').
- Scale low point value.

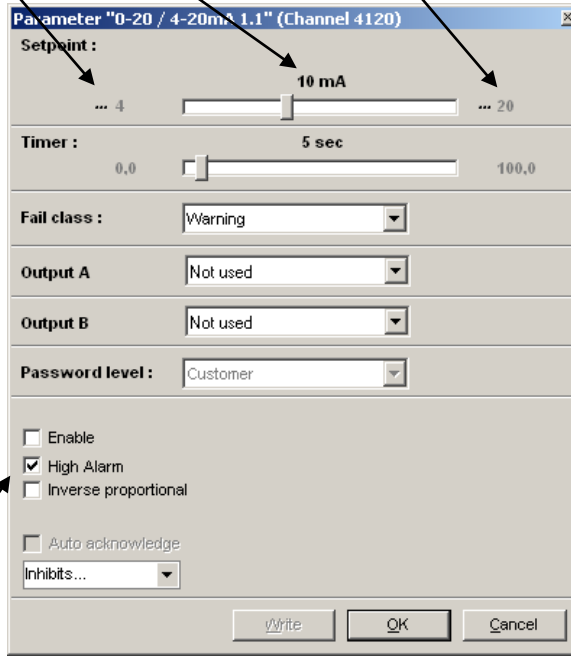

Tick boxes: Select the needed function.

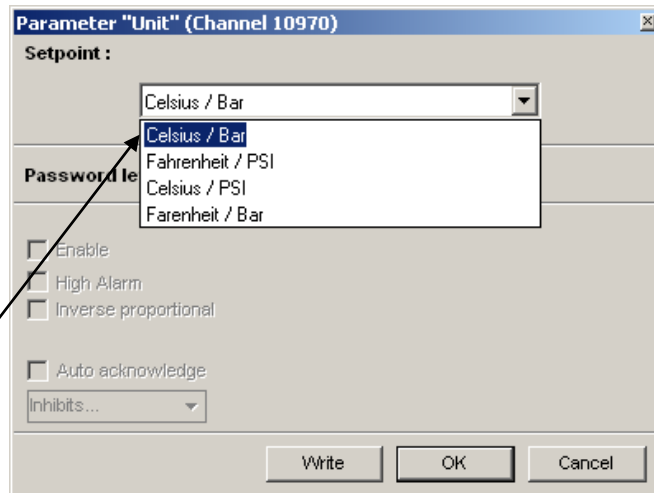

Unit: E.g. Bar, F, C, PSI.

Charger alternator terminal W

The terminal W output is an AC voltage.

Magnetic pick-up

The 2-wire magnetic pick-up can be connected directly to terminals 17-18.

NPN transistor output pick-up

Since the NPN output is a frequency modulated DC pulse signal, a few external components are needed in order to eliminate the DC component.

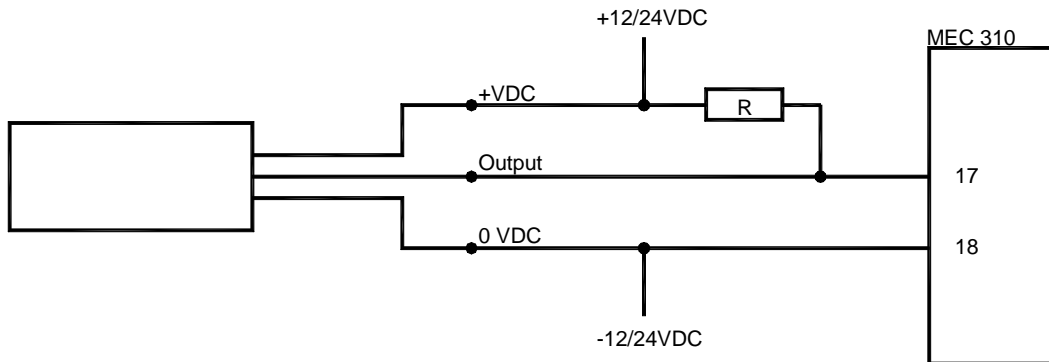

R = 1200Ω (24V DC), 600Ω (12V DC)

PNP transistor output pick-up

Since the PNP output is a frequency modulated DC pulse signal, a few external components are needed in order to eliminate the DC component.

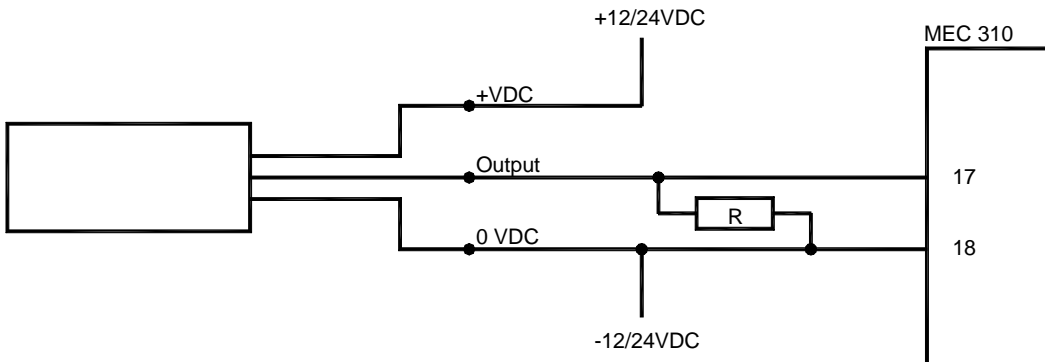

R = 1200Ω (24V DC), 600Ω (12V DC)

Generator breaker control

Breaker closing

Since the generator is assumed to run alone (single generator island), the breaker will close immediately when the Hz/V OK status is reached (AUTO), or if the breaker close button is activated (LOCAL). In LOCAL mode the breaker can be closed by pressing the GB close button on the front of the MEC 310, when Hz/V is OK.

Relay output control

The generator breaker is assumed to be a contactor, i.e. the relay output is steady ON when the breaker is closed, and steady OFF when the breaker is open. It is not possible to have 2 pulse outputs for a motorised breaker (ON and OFF).

Breaker trip control

Any alarm selected to have the fail class *Trip* or *Shutdown* will automatically open the breaker control relay. If the breaker is closed when the idle speed is activated, a breaker out signal will be transmitted.

Breaker ON/OFF feedback

As default there is no feedback for breaker ON or OFF. The breaker position LED is paralleled to the breaker control relay output. It is possible, however, to select a binary input to be breaker ON feedback and/or an OFF feedback. This is done via an extra selection in the input settings of the TPS 300 software. This extra input is called *GB Pos on* or *GB Pos off*.

This icon activates the inputs settings:



If the input *Breaker ON feedback* is selected, then the input must be connected and activated, if the breaker is ON. The reason is that a *Breaker close failure* alarm will appear, if the breaker control relay is activated without the binary input. Also, if the breaker control relay is OFF and the binary input is ON, then a *Breaker open failure* alarm will appear.

These alarms are fixed with the fail class *Warning*.

Engine temperature controlled GB closing

This function can be used, if it is recommendable that the engine cooling water temperature must be above a certain temperature before the engine is loaded. In the parameter 6360 it is possible to set the cooling water temperature that must be exceeded, before the generator breaker is closed.

The function is also enabled/disabled in parameter 6360. An engine heating message is displayed, until the engine cooling water temperature has reached the set point in parameter 6360.

The engine cooling water temperature sensor must be selected to be a VDO sensor to make the function work. If the option A (AMF logic) is enabled, this function will also work upon a mains failure.

Cool-down controlled by engine temperature

The engine temperature-controlled cool-down is to ensure that the engine is cooled down below the set point in parameter 6213 "Cool-down temperature" before the engine is stopped. This is particularly beneficial if the engine has been running for a short period of time, and therefore has not achieved normal cooling water temperature, as the cool-down period will be very short or none

at all and hereby save fuel. If the engine has been running for a long period it will have reached normal running temperature, the cool-down period will be the exact time it takes to lower the temperature to be less than the temperature in set point 6213.

If, for some reason, the engine cannot lower the temperature below the temperature set point in 6230 within the time limit in parameter 6560, the engine will be shut down due to this timer. The reason for this could be high ambient temperature.

The temperature-controlled cool-down function is selected in parameter 6214.

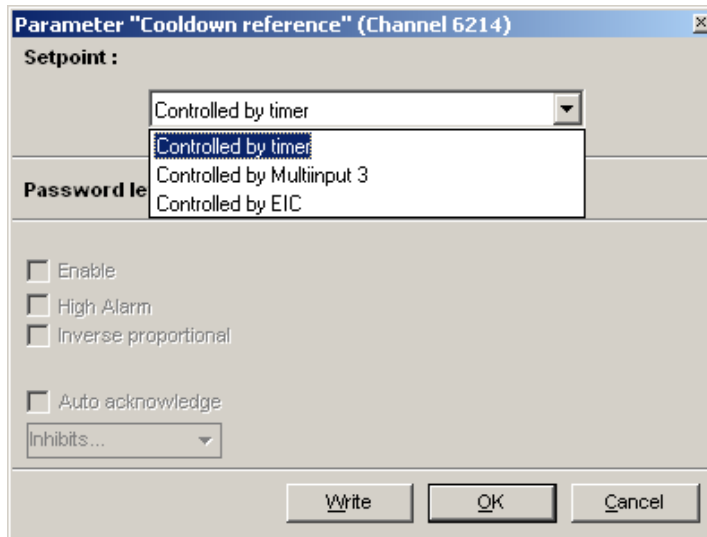

Test function

The MEC 310 has two test sequences if the option A is enabled. The test sequences can be initiated in two ways: Either with the test push-button on the front of the MEC 310 or by a digital input configured to this function.

Simple test function

When the simple test is initiated, the MEC 310 will go through the start sequence and run the engine for the time set in parameter 7090. In this parameter it is also selected if this sequence should be started by a digital input and/or the test push-button on the front of the MEC 310. If the timer is set to 0, the test sequence will be interrupted when the digital input or test push-button is deactivated. This means that digital input can be used to activate and deactivate the test sequence. When the timer runs out or the input is deactivated (timer set to 0), the stop sequence including cooling down will be carried out.



The MEC 310 must be in Auto mode in order to initiate the test sequence.

AMF test function (A dependent)

When the AMF test is initiated, the MEC 310 will go through the AMF sequence and run the engine for the time set in parameter 7040. In this parameter it is also selected if this sequence should be started by a digital input and/or the test push-button on the front of the MEC 310. If the timer is set to 0, the test sequence will be interrupted when the digital input or test push-button is deactivated. This means that digital input can be used to activate and deactivate the test sequence. When the timer runs out or the input is deactivated (timer set to 0), the mains restore sequence and the stop sequence including cooling down will be carried out.

M-logic

M-logic functionality is included in the unit and is not an option-dependent function.

The screenshot displays the M-logic configuration window with a sidebar on the left containing icons for Alarms, Trending, Parameters, Inputs/Outputs, Options, Logs, Translations, and M-Logic. The main area shows six logic rules, each with three input events (A, B, C) and their respective operators (OR). Logic 1 is the only one with 'Enable this rule' checked. Its output is 'Activate buzzer on main' and its delay is 0 seconds. The other rules (Logic 2-6) have 'Enable this rule' unchecked and their outputs are 'Not used'.

M-logic is used to execute different commands at predefined conditions. M-logic is not a PLC but substitutes one, if only very simple commands are needed.

M-logic is a simple tool based on logic events. One or more input conditions are defined, and at the activation of those inputs the defined output will occur. A great variety of inputs can be selected, such as digital inputs, alarm conditions and running conditions. A variety of the outputs can also be selected, such as relay outputs, change of gen-set modes, alarm LEDs and change of running modes.



The M-logic is part of the TPS 300 software, and as such it can only be configured in the TPS 300 software and not via the display.

The main purpose of M-logic is to give the operator/designer more flexible possibilities of operating the generator control system.

Buzzer

The MEC 310 has a built-in buzzer. The buzzer is configured in M-logic. This means that if the buzzer is going to be used as a horn annunciator, the input must be set to 'Horn' and the output must be set to 'Buzzer'. The buzzer will act concurrently to the horn output timer. If the delay timer in M-logic is used, the buzzer will be active after this time delay. See example below.

The screenshot shows the M-logic configuration interface with two logic rules:

- Logic 1:**
 - Event A: NOT Alarm horn: Alarms
 - Operator: OR
 - Event B: NOT Not used
 - Operator: OR
 - NOT
 - Enable this rule:
 - Output: Activate buzzer on main l
 - Delay (sec.): 0
- Logic 2:**
 - NOT Alarm horn: Alarms
 - Operator: OR
 - Event B: NOT Not used
 - Operator: OR
 - NOT
 - Enable this rule:
 - Output: Deactivate buzzer on mai
 - Delay (sec.): 0



If an EAP 300 is connected, the buzzer in the EAP 300 must be configured under the EAP 300 setup. But the configuration of the EAP 300 buzzer is similar to the above.

Upgrade of firmware

1. Connect PC to MEC 310 using Thomson Technology SSP interface
2. Open TPS 300 software(USW) and connect to MEC 310

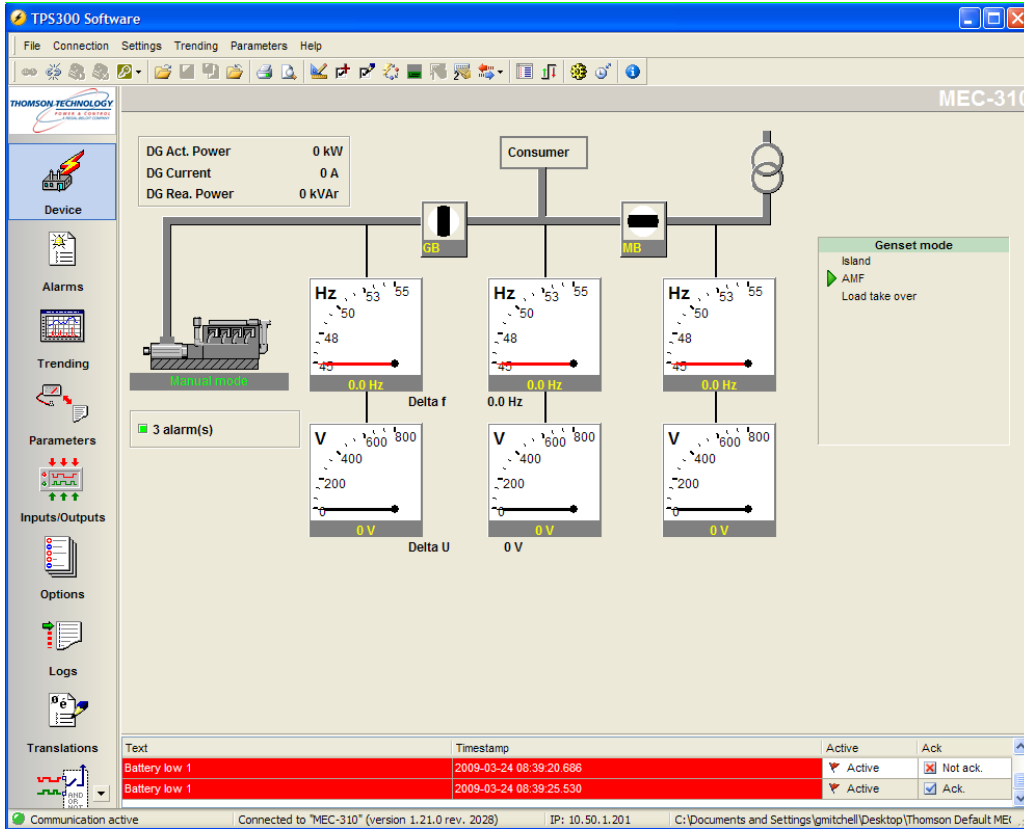

3. Read parameters from MEC 310 using "Batch job" function

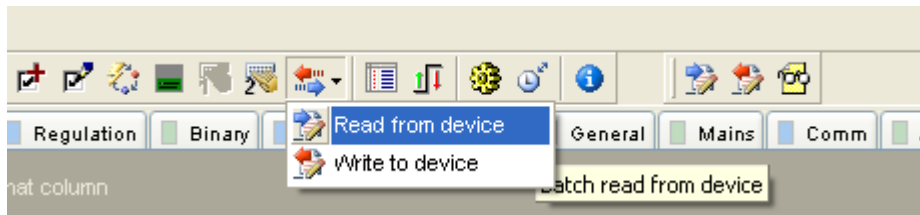

- Select ALL parameters to be saved in USW project file.

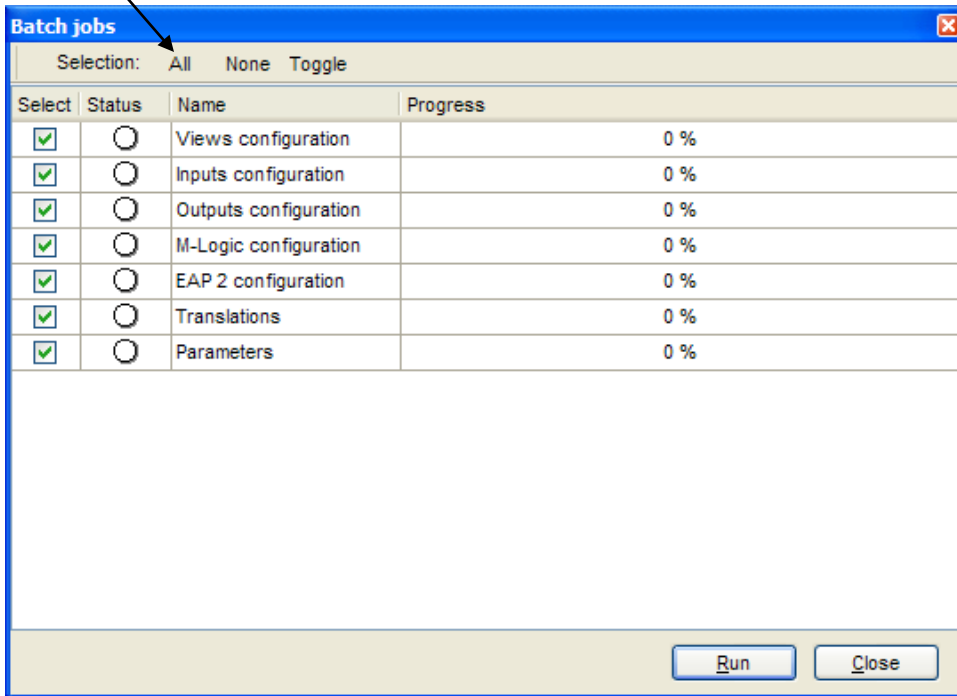

- Choose file name and where to save project file on PC

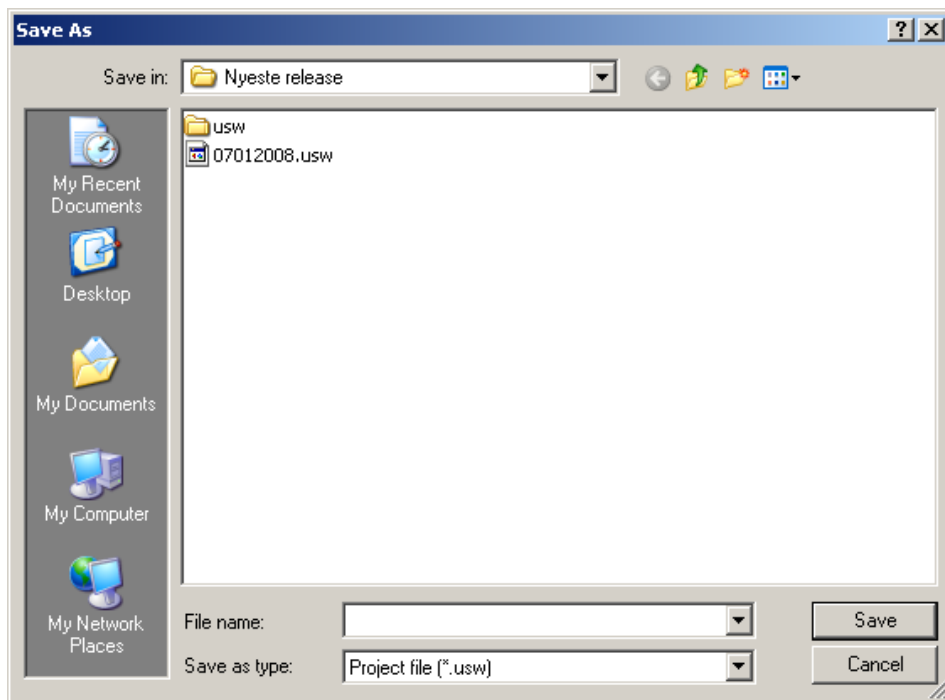

- Press Firmware update button and select new application software (*.A79 file)

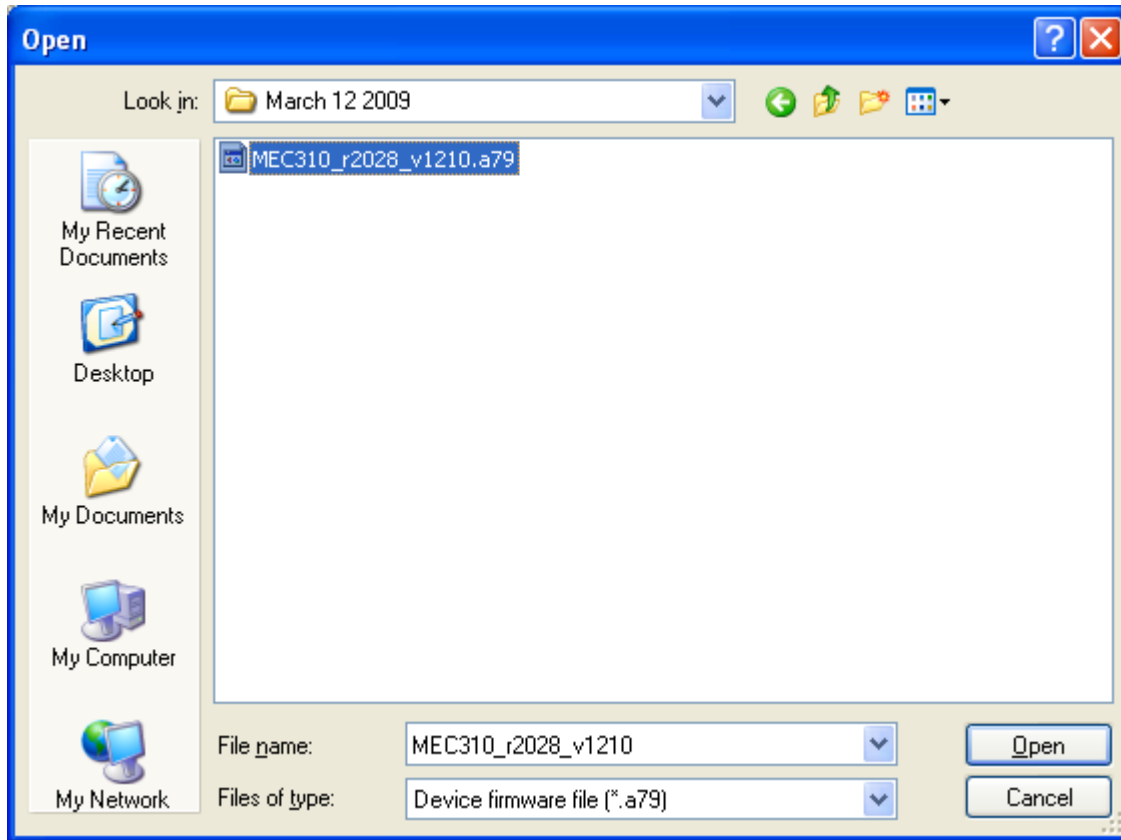

New application software can be downloaded from www.thomsontechnology.com

- This will force MEC 310 into boot mode (LED 1 will flash red)

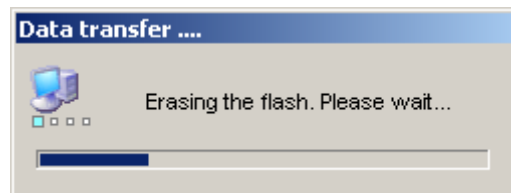

If the programming should be interrupted, it's possible to force the unit back into boot mode by disconnecting Aux. voltage. Press and hold the "OFF" button. Connect Aux. voltage and unit is into boot mode.



Indication of boot mode: blank display and LED 1 flash red.

8. After download of new firmware is done, saved parameters can be downloaded into unit.

9. Open saved project file from PC

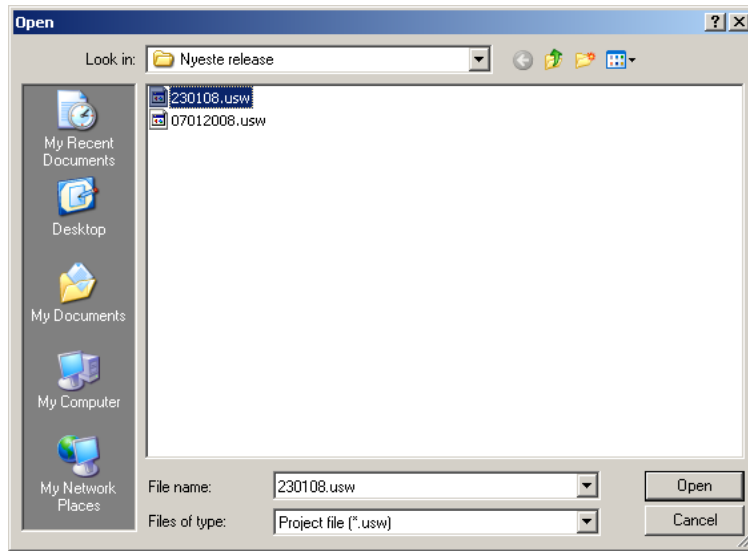

10. Write to device, using "Batch job" function

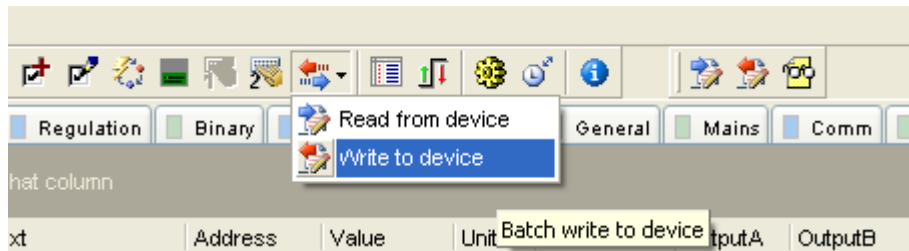

11. Select parameters which want to be downloaded into the unit.

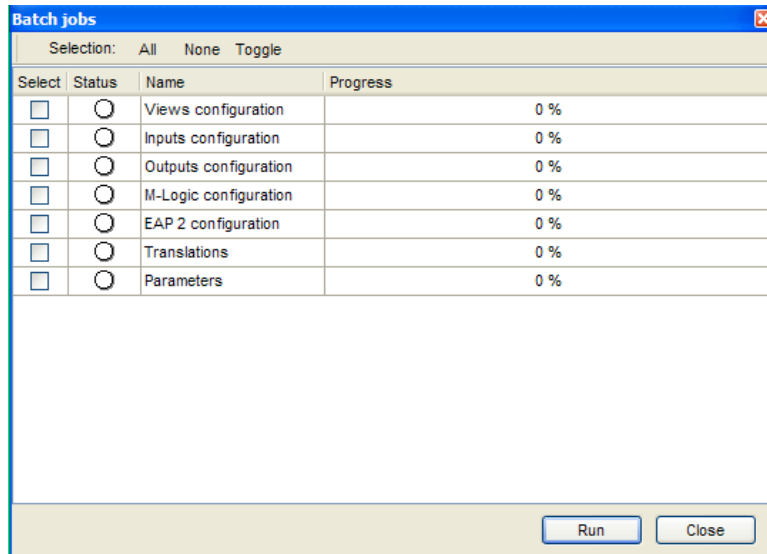

12. Restart unit

GSM communication

GSM communication can be used for 2 purposes:

1. Sending SMS alarm messages to up to 5 different mobile phones. The messages will be sent in clear text, representing the alarm in question (e.g. "Overspeed") and an ID. The ID represents the total numbers of sent SMS.
2. Communicate with the MEC 310 TSP 300 software.

Connection:

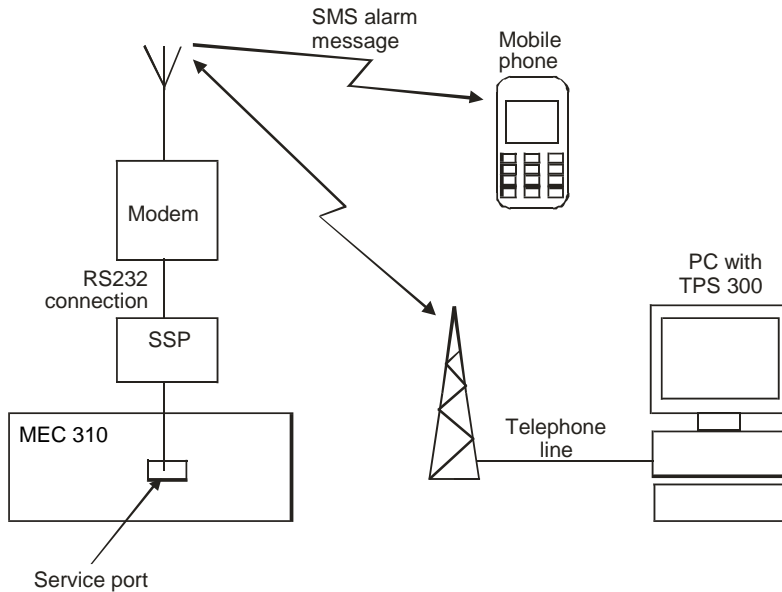

The connection is based on an RS232 connection to a GSM modem via the service port on the MEC 310. Since the connection on the MEC 310 is a TTL communication, the SSP interface box is needed to convert the signals to RS232. The SSP connects via a cable with SUB-D 9-pin female connector on the modem side.

We recommend using Siemens MC35 modem. The easiest way to get the modem is to purchase it through a local dealer. The SIM card needed comes from your local mobile net provider. The easiest way to set the PIN code in the modem itself is to mount the SIM card in a mobile phone and change the PIN code there. The SIM card will remember the PIN code when it is installed in the modem.

 Siemens recommends a short power interruption (30 sec.) once a day to prevent lock-up of the modem. The easiest way to do this is to use a 24 hour watch.

Should an alarm occur during the interruption, the multi-line unit will re-transmit it when the modem starts again, so no messages are lost.

The setting of communication protocol ASCII or RTU can be set in the display.

SMS alarms



SIM card must support data transfer. Contact your GSM provider for details.

1. Setup GSM pin code

2. Setup of Alarm call numbers

3. Connect GSM modem to service port.
4. Disconnect Aux. supply to MEC 310.
5. Connect Aux. supply to MEC 310.
6. MEC 310 will then setup the GSM modem under start up.

TPS 300 software connection via modem



If a TPS 300 software connection is required, then the SIM card must support data transfer. Contact your GSM provider for details.

TPS 300 software

Press the application settings push-button.



The settings dialog box appears:

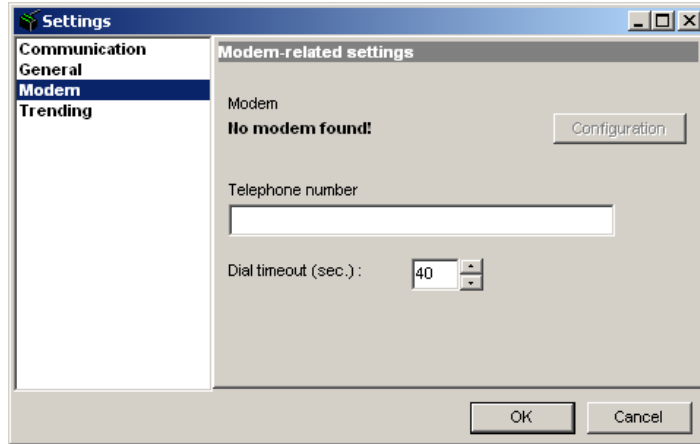

Select modem and key in the telephone number of your GSM modem connected to the unit.



In the above example the modem is selected automatically by the TPS 300 software (internal modem in the PC).

When you want to use modem dial-up, the TPS 300 software must also be set to run ASCII 7 bits data communication:

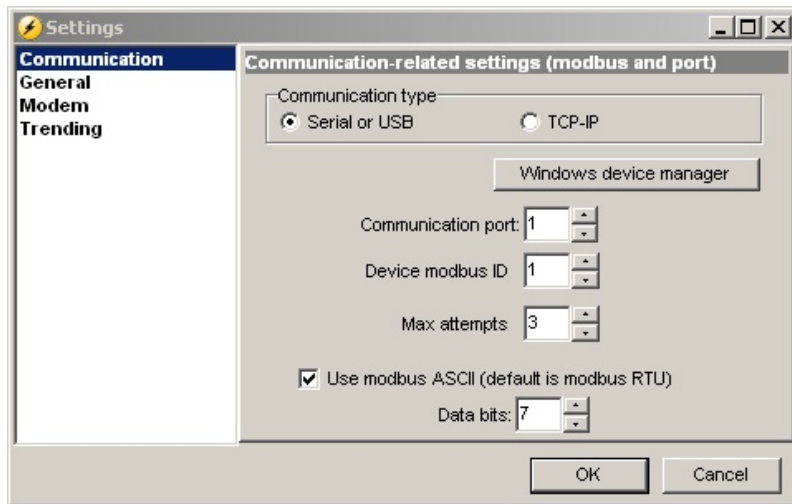

After this, dial-up can be used: Click on the telephone button.

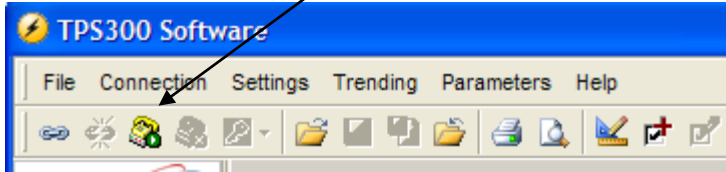

The modem communication is very much slower than the normal direct connection, so please be patient. It is not recommended to download the entire setting list. Use single setting downloads.

TPS 300 software communication safety

If the communication fails, the MEC 310 unit will operate according to the received data. If e.g. only half of the parameter file has been downloaded when the communication is interrupted, the settings are going to be a mix.

Auto engine start

The mains fail is an option

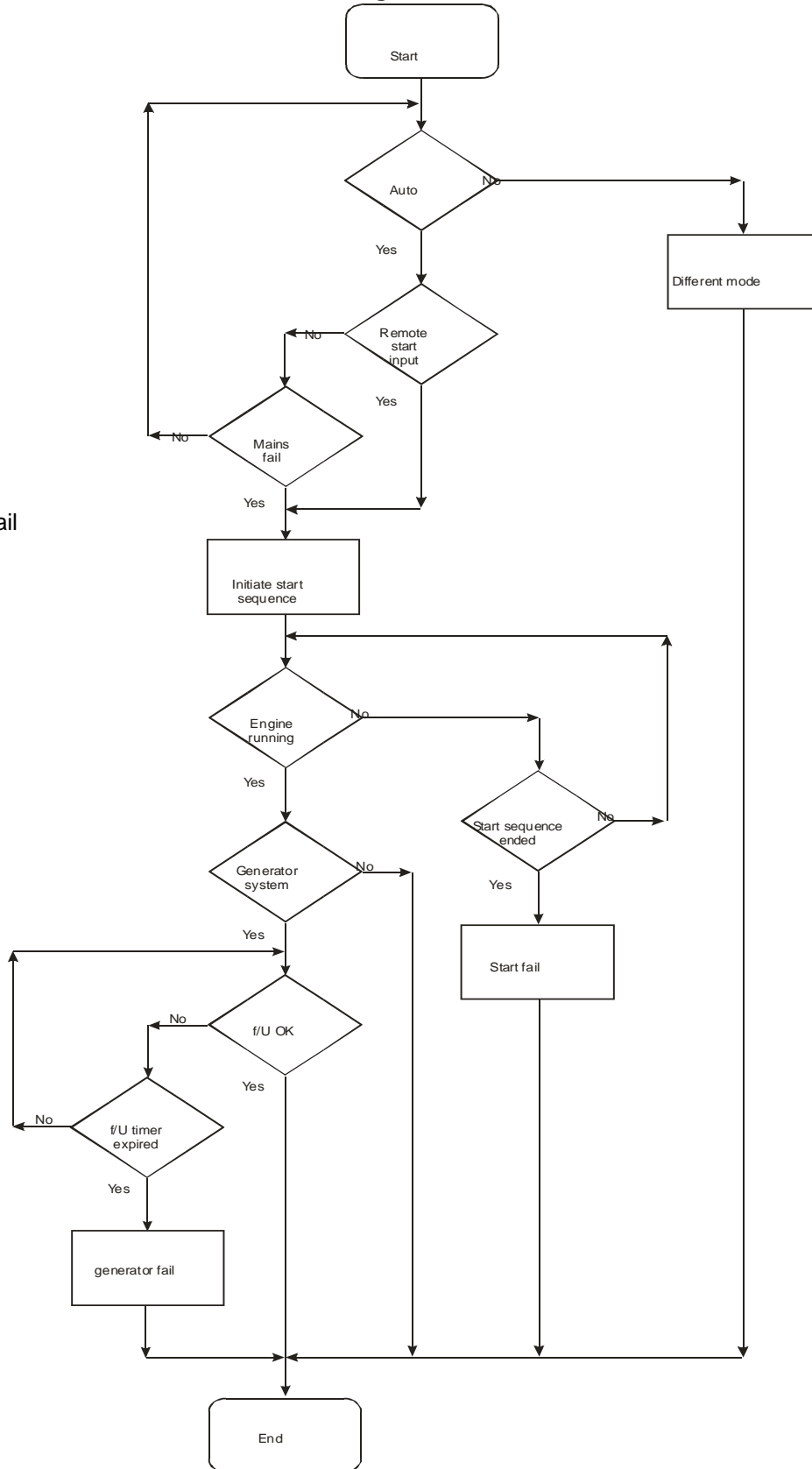

Start sequences

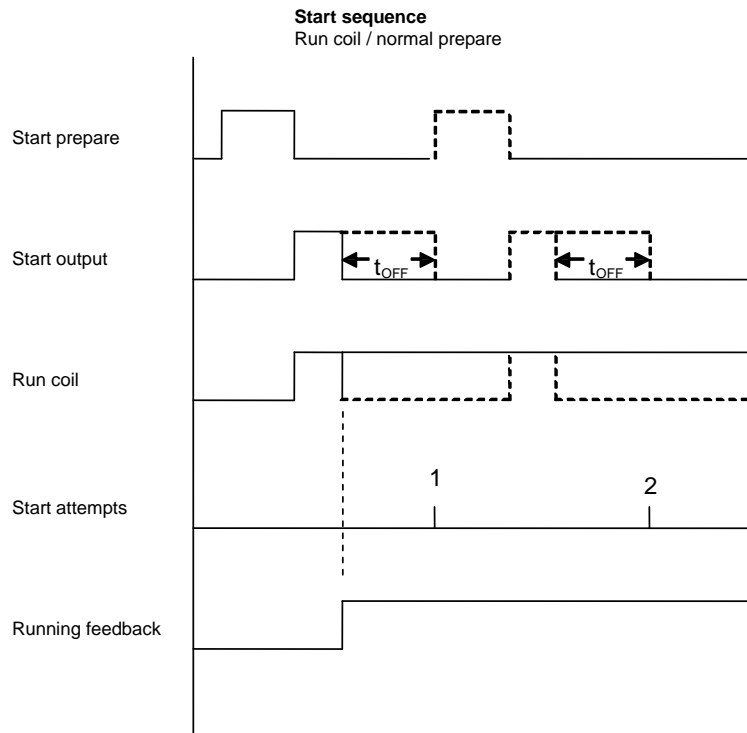
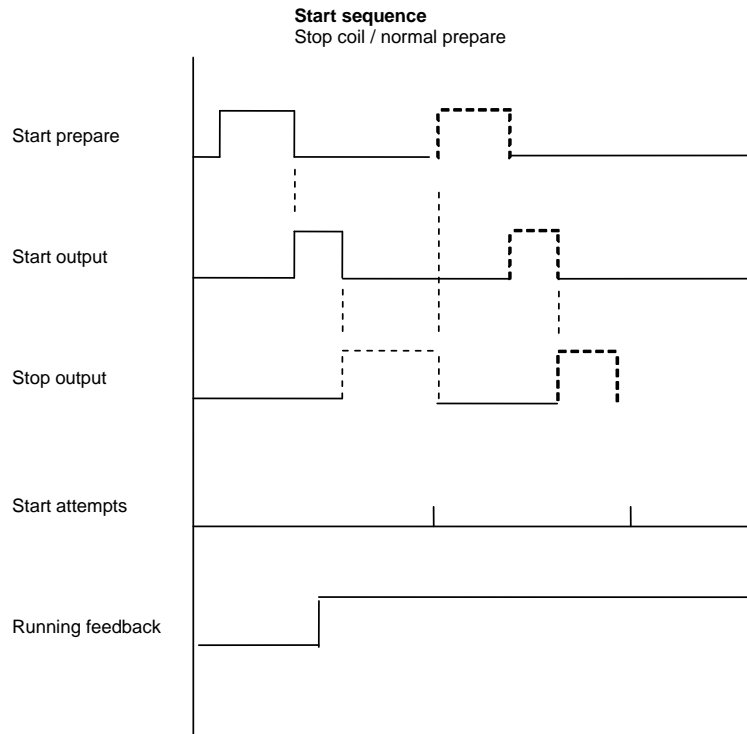

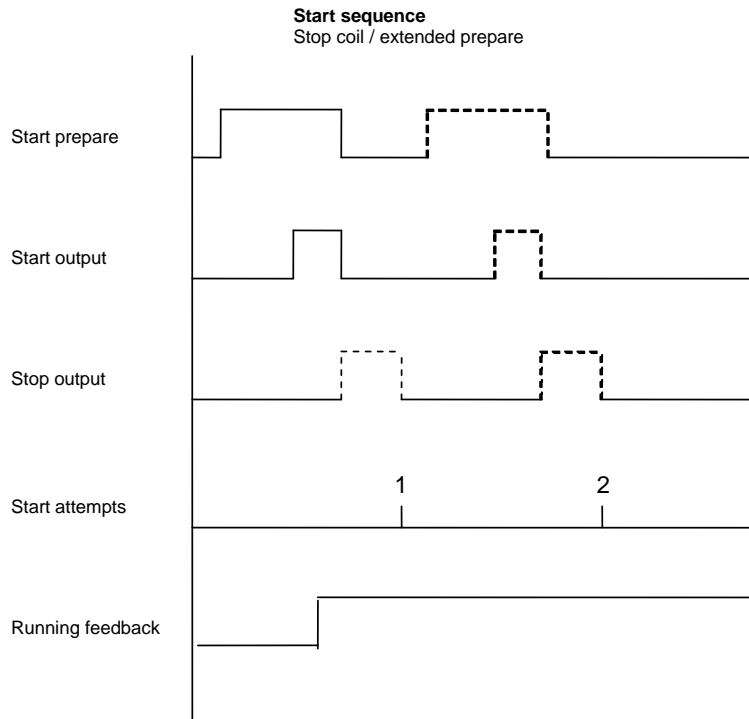
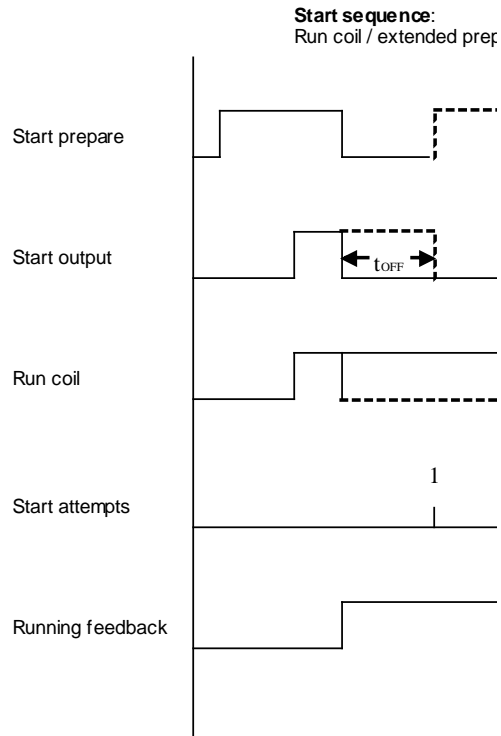

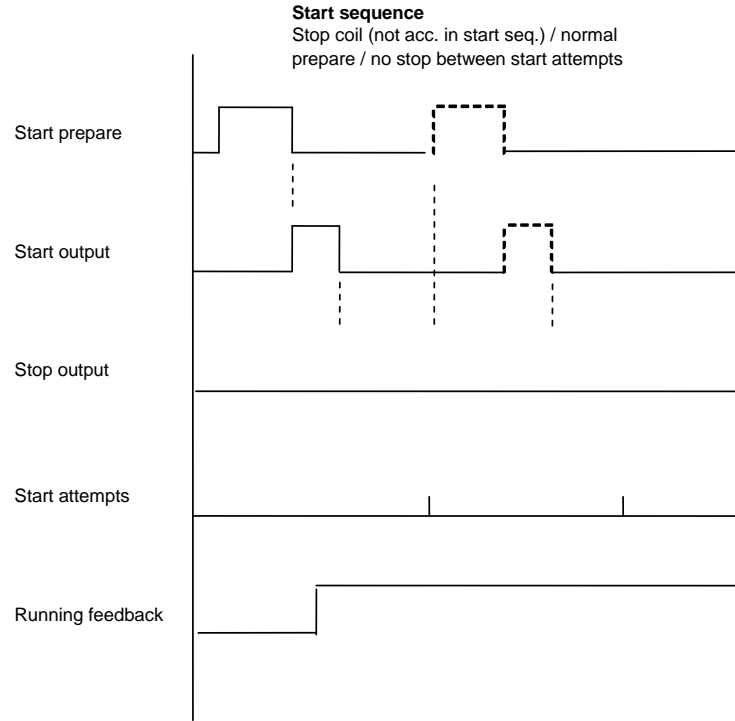

Running feedbacks

- **Voltage/Frequency**
The frequency measurement requires a voltage measurement of 30% U_{NOM} . So the running feedback based on the frequency measurement can only be used where the voltage builds up rapidly.

Selectable running feedbacks

- **RPM input**
Tacho RUN setpoint, menu 6173
- **Charger alternator W input.**
Charger gen. detect menu 4610 (Uses the same RUN setpoint as RPM input, menu 6173)
- **D+**
Binary input
- **Oil pressure**
RUN detect menu 6570

Interruption of start sequence

The start sequence is interrupted in the following situations:

Event	Comment
Auto mode stop	Removal of start cause (binary input) or shutdown.
Start failure	
Running feedback	Tacho set point, menu 6173.
Running feedback	Binary input, D+.
Running feedback	Frequency measurement above 30Hz. The frequency measurement requires a voltage measurement of 30% U_{NOM} . So the running feedback based on the frequency measurement can only be used where the voltage builds up rapidly.
Running feedback	Oil pressure RUN detect menu 6550.
Emergency stop	
Stop push-button on the display	In manual as well as in auto operation.

Start failure alarm – Auto only: Select Auto

The start failure alarm will occur, if the engine has not started after the last start attempt. A start failure will activate the HORN output and relay outputs if selected.

Start prepare

There are two possibilities for use of the start prepare timer:

Normal start prepare	The start prepare relay is activated when the start sequence is initiated for the adjusted time and before each start attempt. It deactivates before cranking.
Extended start prepare	The start prepare relay is activated when the start sequence is initiated, and it stays activated when cranking.

6290 Idle mode

6290 Idle mode can be selected in 2 ways:

1. Configurable binary input
2. Timer setting

If a binary input for idle mode is used, activating this will hold the engine in idle mode for as long as the input is activated. This works for both manual and auto mode. Any time the idle mode is activated, the generator breaker will be opened.

If a binary input is not used, a timer function can be set to hold the engine in idle upon start until the timer runs out. This function can be selected to be:

- Off (no idling of engine upon start)
- Active for:
 - both manual and auto: Select MAN/AUTO.
 - manual only: Select MAN
 - auto only: Select AUTO

In both cases a relay must be selected to Idle in the output list. When idle mode is selected, a delay where the engine is running at low RPM is given. The delay is controlled by the MEC 310, and a relay output will activate the idle control on the engine.

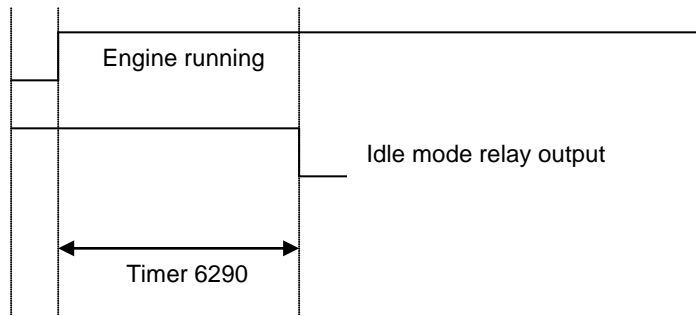

Engine heater

The external heater function can be used to turn on an external heat source, when the engine cooling water temperature gets below the limit in parameter 6320. When the engine cooling water temperature reaches the temperature set point in parameter 6330, the heater is turned off again.

A relay must be selected in the output list to turn this external heat source on/off. The relay will close to turn the heater on or open to turn it off.

This function will only work, if the engine cooling water temperature sensor is selected to be a VDO sensor.

Stop sequences

The illustrations indicate the stop sequence schematically.

Stop sequence / RUN coil

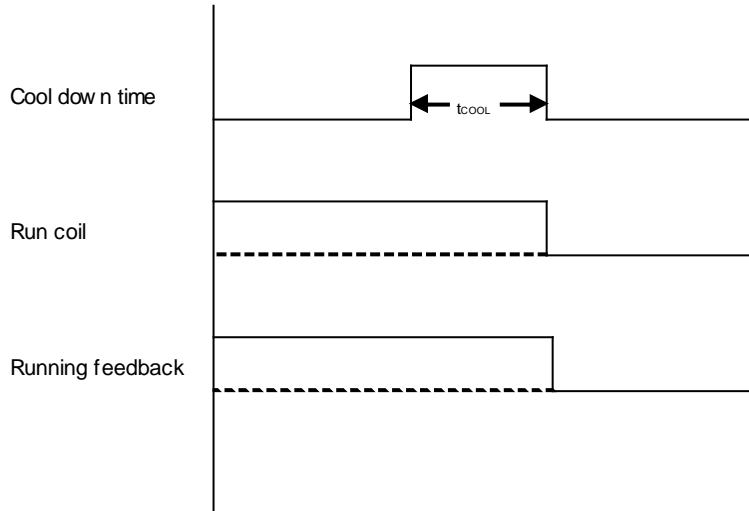

Stop sequence / STOP coil

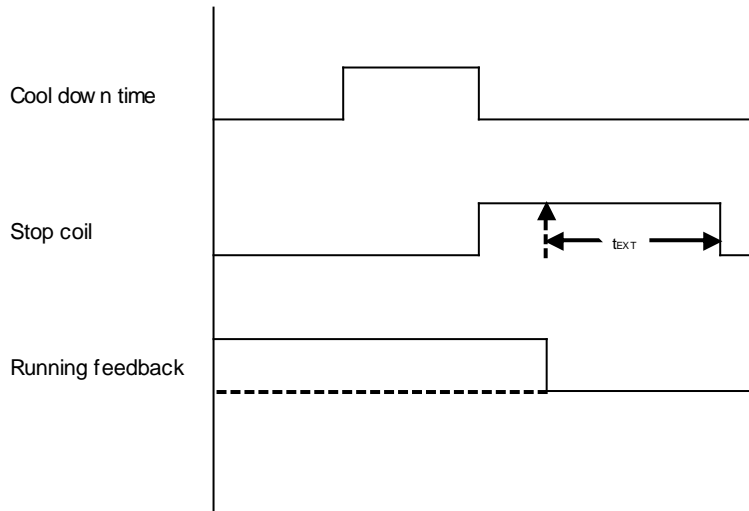

**Stop sequence / Stop coil and
Stop coil (not acc. in start seq.)**

Stop sequence

The stop sequence will be activated, if a stop command is given. The stop sequence can include the cooling down time, if the stop is a normal or controlled stop.

Description	Cooling down	Stop	Comment
Auto mode stop	X	X	
Trip and stop	X	X	
Stop button on display		X	
Binary shutdown input		X	
Emergency stop		X	Engine shutdown and GB opens.
Stop command (M-logic)		X	

The stop sequence can only be interrupted during the cool down period. Interruptions can occur in these situations:

Event	Comment
Start button is pressed	Manual mode only. Engine will run in idle speed if idle is ON.
Binary start input	Auto mode.
GB close button is pressed	Manual mode only.

Stop failure alarm

A stop failure alarm will occur, if the running feedback (or the generator voltage and frequency) is still present. The stop failure timer is adjusted in menu 4580. Stop failure will activate the HORN output, and relay outputs if selected. Factory setting is no relay outputs besides horn.

5. Parameter list

This chapter includes a complete standard parameter list for setup. Therefore, this chapter is to be used for reference, when information about specific parameters is needed.

Parameter groups

In the parameter overview, the parameters are divided into three parameter groups. The parameter groups can be enabled and disabled in the parameters 6950-6970. If a parameter group is enabled, the parameters will be accessible from the display of the MEC 310. To see the specific parameter, see in the parameter list. If e.g. a parameter is marked (P2), it is available from the display, if parameter group 2 is enabled. The default display parameter setting is the parameter setting that will always be present in the display parameter list. These parameters are marked with a *.

Setup

The setup of parameters is performed via the display or the TPS 300 software. Therefore, the default settings can be changed to the relevant settings through the TPS 300 software or by means of the push-buttons on the display.

The settings can be entered through the setup menu. If no entry has taken place before, then the first display to appear is the password display. Enter the factory setting password to gain access to the menus.



The factory Customer password is 2000. The factory Service password is 2001.

If no action has been taken after 30 seconds, then the password entry will be deactivated, and a new password entry is needed. (If entry via the TPS 300 is used, the password is only needed once per connection).

Each parameter description is structured according to the same principles. Under the parameter title heading, the detailed parameter descriptions are illustrated and presented. First, a table indicating the parameter facts related to the individual parameter title is presented:

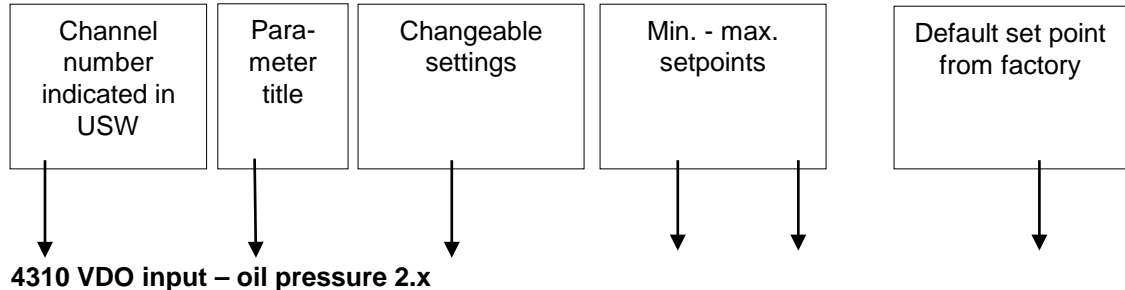

No.	Setting		Min. setting	Max. setting	Factory setting
4311	Oil pressure 2.1	Set point	0.0 bar	10.0 bar	4.0 bar
4312	Oil pressure 2.1	Delay	0.0 s	100.0 s	5.0 s
4313	Oil pressure 2.1	Output A	R0 (none)	R26 (relay 26)	R0 (none)
4314	Oil pressure 2.1	Output B	R0 (none)	R26 (relay 26)	R0 (none)
4315	Oil pressure 2.1	Enable	OFF	ON	OFF
4316	Oil pressure 2.1	Fail class	Warning	Shutdown	Trip of GB

The first column indicates the channel number in the TPS 300.

The second column indicates the changeable setting in the TPS 300 software.

The third and fourth columns indicate the minimum/maximum set point available for this setting.

The fifth column indicates the default set point of the unit from the factory.

When it is necessary, additional information will be supplied after the table in order to make the individual parameter descriptions as informative as possible.

Parameter overview

Parameter group 1 (Disp. view settings)	7513 Service mode (RTU/ASCII)
6181 Start prepare	7560 Engine I/F
6183 Start On time	Hour adjust. ("Sync. clock" to PC button)
6184 Start Off time	Minutes adjust. ("Sync. Clock" to PC button)
6211 Cool-down	Seconds Adjust.("Sync. Clock" to PC button)
6212 Extended stop	Date adjust ("Sync. Clock" to PC button)
Parameter group 2 (Disp. view settings)	Month adjust ("Sync. Clock" to PC button)
1030 Overcurrent 1: Delay + Setpoint	Year adjust ("Sync. Clock" to PC button)
1040 Overcurrent 2: Delay + Setpoint	Parameters only configurable from USW
1150 Overvoltage 1: Delay + Setpoint	1000 Reverse power
1160 Overvoltage 2: Delay + Setpoint	2150 Phase sequence error
1170 Undervoltage 1: Delay + Setpoint	2280 Phase rotation
1180 Undervoltage 2: Delay + Setpoint	2160-2170 GB control
1210 Overfrequency 1: Delay + Setpoint	2770 EIC control
1220 Overfrequency 2: Delay + Setpoint	3000-3050 Digital input term. 10-15
1240 Underfrequency 1: Delay + Setpoint	3490 Emergency stop
1250 Underfrequency 2: Delay + Setpoint	3400...3420 Binary multi input settings
1450 Overload 1: Delay + Setpoint	4120...4390 mA input settings
1460 Overload 2: Delay + Setpoint	4310...4470 VDO multi input settings
Parameter group 3 (Disp. view settings)	4510 Gen. overspeed 1
4220 Fuel 1.1: Delay + Setpoint*	4520 Gen. overspeed 2
4230 Fuel 1.2: Delay + Setpoint*	4580 Stop fail
4620 Fuel 1.3: Delay + Setpoint*	4630 Low water temp.
4600 V-belt: Delay	4950 Battery low 2
4610 Charger gen: Delay	5000...5060 Relay functions
6350 D+: Delay	6001...6005 Nominal settings 1
6550 Fuel pump: Delay*	6006 Enable nom. Settings
6551 Fuel pump 1: Setpoint*	6011...6015 Nominal settings 2
6552 Fuel pump 2: Setpoint*	6021...6025 Nominal settings 3 (1 ph)
* Only shown if multi-input 1 is set to VDO	6031...6035 Nominal settings 4 (2ph)
Always shown parameters in display	6041 Transformer U pri. Gen.
4560 Hz/V failure timer	6042 Transformer U sec. Gen.
4580 Stop fail	6043 Transformer I pri. Gen.
4960 Battery low 1: Delay + Setpoint	6044 Transformer I sec. Gen.
4970 Battery High: Delay + Setpoint	6080 Language
6101 Running time	6101 Running time
6105 kWh reset	6160 Run status
6112 Service timer 1: Hours	6171 Tacho – teeth
6113 Service timer 1: Days	6173 Tacho – run setpoint
6116 Service timer 1: Reset	6191 Start attempts
6122 Service timer 2: Hours	6213 Cool-down temperature
6123 Service timer 2: Days	6214 Cool-down reference
6126 Service timer 2: Reset	6290 Idle mode
6130 Alarm horn	6320 Engine heater ON

6221 Hz/V OK timer	6330 Engine heater OFF
6222 Hz/V OK voltage	6560 Cool-down timeout
6223 Hz/V OK frequency	6570 Oil pres. RUN detect
Parameters only configurable from USW	10010 Cmd.1 Days(S)
6700 Diode compensation	10020 Cmd.1 Hour(S)
6940 Alarm LED function	10030 Cmd.1 Minute(S)
6950 Parameter group 1	10040...10310 Cmd.2.....Cmd.8
6960 Parameter group 2	10320-10370 GSM pin code and numbers
6970 Parameter group 3	10470-10610 Fuel level config. sensor
6980 Sleep mode settings	10640-10780 Oil pressure config. sensor
7090 Island test function	10810-10950 Water temp. config sensor
7570-7660 EIC alarms configuration	10970 Unit settings
9116 Password – customer	10980 Multi input 1 selection (VDO/mA/Bin)
9117 Password – service	10990 Multi input 2 selection (VDO/mA/Bin)
10000 Cmd.1 Tim/start/stop	11000 Multi input 3 selection (VDO/mA/Bin)

Parameter list for standard MEC 310 unit without options

Parameter table description

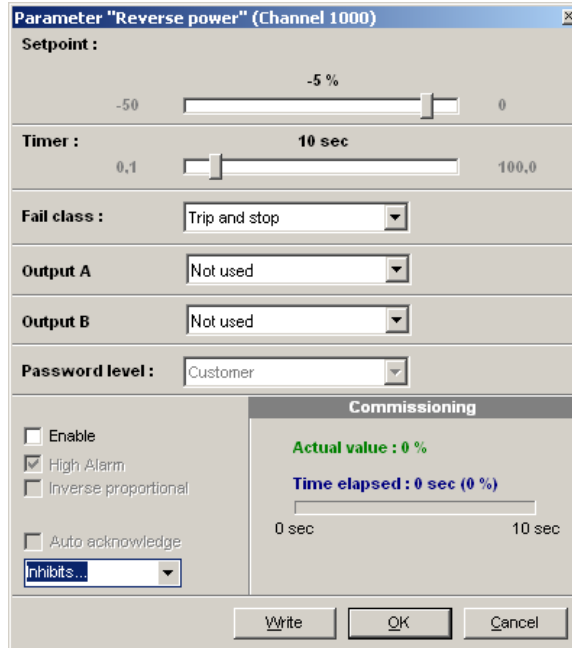

The table consists of the following possible adjustments:

Set point: The alarm set point is adjusted in the set point menu. The setting can be in percentage of the nominal values.

Timer (delay): The timer setting is the time that must expire from the alarm level is reached until the alarm occurs.

Relay output A: A relay can be activated by output A.

Relay output B: A relay can be activated by output B.

Enable: The alarm can be activated or deactivated. ON means always activated.

Inhibits: It is possible to inhibit some of the alarms. This means it is only activated when the running feedback signal is present.

Inhibit functions:

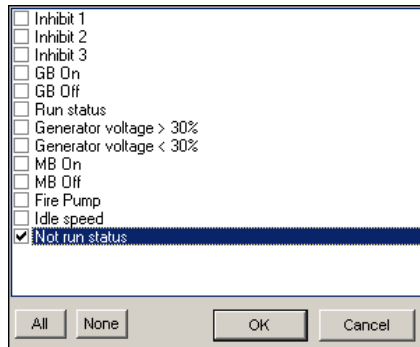

Fail class: When the alarm occurs, the unit will react depending on the selected fail class.



Small differences due to the character of the parameters may exist between the individual tables.

Fail class

The fail class settings for the protections have the following possibilities:

Value	Comment
0: Warning	Shown in alarm pop-up window and activates the chosen relays.
1: Trip	Shown in alarm pop-up window and activates the chosen relays. Trips the breaker.
2: Trip and stop	Shown in alarm pop-up window and activates the chosen relays. Trips the breaker, cools down the engine and stops it.
3: Shutdown	Shown in alarm pop-up window and activates the chosen relays. Trips the breaker and shuts the engine down immediately.

Engine alarm settings (protection)

1000 Reverse power

No.	Setting		Min. setting	Max. setting	Third setting	Factory setting
1001	Reverse power	Set point	-50.0%	0.0%	-	-5.0%
1002	Reverse power	Timer	0.1 s	100.0 s	-	10.0 s
1003	Reverse power	Relay output A	R0 (none)	R26 (relay 26)	-	R0 (none)
1004	Reverse power	Relay output B	R0 (none)	R26 (relay 26)	-	R0 (none)
1005	Reverse power	Enable	OFF	ON	Inhibit	ON
1006	Reverse power	Fail class	Warning	Shutdown	-	Trip

1030 Gen Overcurrent 1

No.	Setting		Min. setting	Max. setting	Third setting	Factory setting
1031	Overcurrent 1 (P2)	Set point	50.0%	200.0%	-	115.0%
1032	Overcurrent 1 (P2)	Timer	0.1 s	3200.0 s	-	10.0 s
1033	Overcurrent 1	Relay output A	R0 (none)	R26 (relay 26)	-	R0 (none)
1034	Overcurrent 1	Relay output B	R0 (none)	R26 (relay 26)	-	R0 (none)
1035	Overcurrent 1	Enable	OFF	ON	Inhibit	ON
1036	Overcurrent 1	Fail class	Warning	Shutdown	-	Trip

1040 Gen Overcurrent 2

No.	Setting		Min. setting	Max. setting	Third setting	Factory setting
1041	Overcurrent 2 (P2)	Set point	50.0%	200.0%	-	120.0%
1042	Overcurrent 2 (P2)	Timer	0.1 s	3200.0 s	-	5.0 s
1043	Overcurrent 2	Relay output A	R0 (none)	R26 (relay 26)	-	R0 (none)
1044	Overcurrent 2	Relay output B	R0 (none)	R26 (relay 26)	-	R0 (none)
1045	Overcurrent 2	Enable	OFF	ON	Inhibit	ON
1046	Overcurrent 2	Fail class	Warning	Shutdown	-	Trip

1150 Gen Overvoltage

No.	Setting		Min. setting	Max. setting	Third setting	Factory setting
1151	Overvoltage (P2)	Set point	80.0%	150.0%	-	115.0%
1152	Overvoltage (P2)	Timer	0.1 s	100.0 s	-	10.0 s
1153	Overvoltage	Relay output A	R0 (none)	R26 (relay 26)	-	R0 (none)
1154	Overvoltage	Relay output B	R0 (none)	R26 (relay 26)	-	R0 (none)
1155	Overvoltage	Enable	OFF	ON	Inhibit	ON
1156	Overvoltage	Fail class	Warning	Shutdown	-	Warning

1160 Gen overvoltage 2

No.	Setting		Min. setting	Max. setting	Third setting	Factory setting
1161	Overvoltage2(P2)	Set point	80.0%	120.0%	-	117.0%
1162	Overvoltage2(P2)	Timer	0.1 s	100.0 s	-	10.0 s
1163	Overvoltage2	Relay output A	R0 (none)	R26 (relay 26)	-	R0 (none)
1164	Overvoltage2	Relay output B	R0 (none)	R26 (relay 26)	-	R0 (none)
1165	Overvoltage2	Enable	OFF	ON	Inhibits	ON
1166	Overvoltage2	Fail class	Warning	Shutdown	-	Warning

1170 Gen undervoltage

No.	Setting		Min. setting	Max. setting	Third setting	Factory setting
1171	Undervoltage (P2)	Set point	50.0%	110.0%	-	90.0%
1172	Undervoltage (P2)	Timer	0.1 s	100.0 s	-	5.0 s
1173	Undervoltage	Relay output A	R0 (none)	R26 (relay 26)	-	R0 (none)
1174	Undervoltage	Relay output B	R0 (none)	R26 (relay 26)	-	R0 (none)
1175	Undervoltage	Enable	OFF	ON	Inhibit	ON
1176	Undervoltage	Fail class	Warning	Shutdown	-	Warning

1180 Gen undervoltage 2

No.	Setting		Min. setting	Max. setting	Third setting	Factory setting
1171	Undervoltage2(P2)	Set point	50.0%	110.0%	-	85.0%
1172	Undervoltage2(P2)	Timer	0.1 s	100.0 s	-	5.0 s
1173	Undervoltage2	Relay output A	R0 (none)	R26 (relay 26)	-	R0 (none)
1174	Undervoltage2	Relay output B	R0 (none)	R26 (relay 26)	-	R0 (none)
1175	Undervoltage2	Enable	OFF	ON	Inhibits	ON
1176	Undervoltage2	Fail class	Warning	Shutdown	-	Warning

1210 Gen overfrequency

No.	Setting		Min. setting	Max. setting	Third setting	Factory setting
1211	Overfrequency (P2)	Set point	80.0%	150.0%	-	115.0%
1212	Overfrequency (P2)	Timer	0.1 s	100.0 s	-	10.0 s
1213	Overfrequency	Relay output A	R0 (none)	R26 (relay 26)	-	R0 (none)
1214	Overfrequency	Relay output B	R0 (none)	R26 (relay 26)	-	R0 (none)
1215	Overfrequency	Enable	OFF	ON	Inhibit	ON
1216	Overfrequency	Fail class	Warning	Shutdown	-	Warning

1220 Gen overfrequency 2

No.	Setting		Min. setting	Max. setting	Third setting	Factory setting
1221	Overfrequency 2	Set point	80.0%	120.0%	-	117.0%
1222	Overfrequency 2	Timer	0.1 s	100.0 s	-	10.0 s
1223	Overfrequency 2	Relay output A	R0 (none)	R26 (relay 26)	-	R0 (none)
1224	Overfrequency 2	Relay output B	R0 (none)	R26 (relay 26)	-	R0 (none)
1225	Overfrequency 2	Enable	OFF	ON	Inhibits	ON
1226	Overfrequency 2	Fail class	Warning	Shutdown	-	Warning

1240 Gen underfrequency

No.	Setting		Min. setting	Max. setting	Third setting	Factory setting
1241	Underfrequency (P2)	Set point	50.0%	110.0%	-	90.0%
1242	Underfrequency (P2)	Timer	0.1 s	100.0 s	-	5.0 s
1243	Underfrequency	Relay output A	R0 (none)	R26 (relay 26)	-	R0 (none)
1244	Underfrequency	Relay output B	R0 (none)	R26 (relay 26)	-	R0 (none)
1245	Underfrequency	Enable	OFF	ON	Inhibit	ON
1246	Underfrequency	Fail class	Warning	Shutdown	-	Warning

1250 Gen underfrequency 2

No.	Setting		Min. setting	Max. setting	Third setting	Factory setting
1251	Underfrequency 2 (P2)	Set point	50.0%	110.0%	-	85.0%
1252	Underfrequency 2 (P2)	Timer	0.1 s	100.0 s	-	5.0 s
1253	Underfrequency 2	Relay output A	R0 (none)	R26 (relay 26)	-	R0 (none)
1254	Underfrequency 2	Relay output B	R0 (none)	R26 (relay 26)	-	R0 (none)
1255	Underfrequency 2	Enable	OFF	ON	Inhibits	ON
1256	Underfrequency 2	Fail class	Warning	Shutdown	-	Warning

1450 Gen overload 1

No.	Setting		Min. setting	Max. setting	Third setting	Factory setting
1451	Overload 1(P2)	Set point	10.0%	200.0%	-	100.0%
1452	Overload 1(P2)	Timer	0.1 s	3200.0 s	-	5.0 s
1453	Overload 1	Relay output A	R0 (none)	R26 (relay 26)	-	R0 (none)
1454	Overload 1	Relay output B	R0 (none)	R26 (relay 26)	-	R0 (none)
1455	Overload 1	Enable	OFF	ON	Inhibits	ON
1456	Overload 1	Fail class	Warning	Shutdown	-	Warning

1460 Gen overload 2

No.	Setting		Min. setting	Max. setting	Third setting	Factory setting
1461	Overload 2(P2)	Set point	10.0%	200.0%	-	110.0%
1462	Overload 2(P2)	Timer	0.1 s	3200.0 s	-	5.0 s
1463	Overload 2	Relay output A	R0 (none)	R26 (relay 26)	-	R0 (none)
1464	Overload 2	Relay output B	R0 (none)	R26 (relay 26)	-	R0 (none)
1465	Overload 2	Enable	OFF	ON	Inhibits	ON
1466	Overload 2	Fail class	Warning	Shutdown	-	Warning

2150 Phase sequence error

No.	Setting		Min. setting	Max. setting	Third setting	Factory setting
2152	Phase seq error	Timer	0.0 s	10.0 s	-	1.0 s
2153	Phase seq error	Relay output A	R0 (none)	R26 (relay 26)	-	R0 (none)
2154	Phase seq error	Relay output B	R0 (none)	R26 (relay 26)	-	R0 (none)
2155	Phase seq error	Enable	OFF	ON	Inhibit	OFF
2156	Phase seq error	Fail class	Warning	Shutdown	-	Warning

2160 GB open failure

No.	Setting		Min. setting	Max. setting	Factory setting
2161	GB open failure	Timer	0.0 s	10.0 s	1.0 s

2170 GB close failure

No.	Setting		Min. setting	Max. setting	Factory setting
2171	GB close failure	Timer	0.0 s	10.0 s	1.0 s

2280 Phase rotation

No.	Setting		Min. setting	Max. setting	Factory setting
2281	Phase rotation	Setpoint	L1L2L3	L1L3L2	L1L2L3
2282	Phase rotation	Password	Customer	Service	Customer



The setting of Phase rotation depends of the wiring of Mains L1, L2 and L3.

2770 EIC control

No.	Setting		Min. setting	Max. setting	Factory setting
2771	EIC Control	Droop	0.0%	25.0%	0.0%
2772	EIC Control	Scania rpm	User 1500 rpm 1800 rpm Low idle		User
2773	EIC Control	Cummins gain	0.00	10.00	5.00

3000-3050 Digital input term. 10-15, without wire break

No.	Setting		Min. setting	Max. setting	Third setting	Factory setting
30X1	Dig. input no. XX	Timer	0.0 s	3200.0 s	-	10.0 s
30X2	Dig. input no. XX	Relay output A	R0 (none)	R26 (relay 26)	-	R0 (none)
30X3	Dig. input no. XX	Relay output B	R0 (none)	R26 (relay 26)	-	R0 (none)
30X4	Dig. input no. XX	Enable	OFF	ON	Inhibit	OFF
30X5	Dig. input no. XX	Fail class	See description of fail classes			
30X6	Dig. input no. XX	NO/NC	NO	NC	-	NO

3490 Emergency stop (terminal 19-20)

No.	Setting		Min. setting	Max. setting	Factory setting	
3491	Emergency STOP	Timer	0.0 s	60.0 s	0.2 s	
3492	Emergency STOP	Relay output A	R0 (none)	R26 (relay 26)	R0 (none)	
3493	Emergency STOP	Relay output B	R0 (none)	R26 (relay 26)	R0 (none)	
3494	Emergency STOP	Enable	OFF	ON	ON	
3495	Emergency STOP	Fail class	See description of fail classes			

Multi-inputs



It is possible to combine VDO inputs with binary inputs and (0)4...20mA inputs in a mix.

Binary inputs with wire break

The text for the inputs for correct display reading can only be done via the TPS 300 software.

3400 Binary input 1 (fuel)

No.	Setting		Min. setting	Max. setting	Factory setting
3401	Binary input 1	Wire break	OFF	ON	OFF
3402	Binary input 1	Delay	0.0 s	100.0 s	5.0 s
3403	Binary input 1	Output A	R0 (none)	R26 (relay 26)	R0 (none)
3404	Binary input 1	Output B	R0 (none)	R26 (relay 26)	R0 (none)
3405	Binary input 1	Enable	OFF	ON	OFF
3406	Binary input 1	Fail class	See description of fail classes		

3410 Binary input 2 (oil)

No.	Setting		Min. setting	Max. setting	Factory setting
3411	Binary input 2	Wire break	OFF	ON	OFF
3412	Binary input 2	Delay	0.0 s	100.0 s	5.0 s
3413	Binary input 2	Output A	R0 (none)	R26 (relay 26)	R0 (none)
3414	Binary input 2	Output B	R0 (none)	R26 (relay 26)	R0 (none)
3415	Binary input 2	Enable	OFF	ON	OFF
3416	Binary input 2	Fail class	See description of fail classes		

3420 Binary input 3 (temp.)

No.	Setting		Min. setting	Max. setting	Factory setting
3421	Binary input 3	Wire break	OFF	ON	OFF
3422	Binary input 3	Delay	0.0 s	100.0 s	5.0 s
3423	Binary input 3	Output A	R0 (none)	R26 (relay 26)	R0 (none)
3424	Binary input 3	Output B	R0 (none)	R26 (relay 26)	R0 (none)
3425	Binary input 3	Enable	OFF	ON	OFF
3426	Binary input 3	Fail class	See description of fail classes		

Analogue inputs 0(4)-20mA

The scaling of the 0(4)-20mA inputs for correct display reading can only be done via the TPS 300 software.



4-20mA inputs have wire break function. Wire break alarm will be active when current goes below 2,5mA. It's not possible to disable the wire break function.

4120 0-20 4-20mA 1.1

No.	Setting		Min. setting	Max. setting	Factory setting
4121	0(4)-20mA 1.1	Set point	4mA	20mA	10mA
4122	0(4)-20mA 1.1	Delay	0.0 s	100.0 s	5.0 s
4123	0(4)-20mA 1.1	Output A	R0 (none)	R26 (relay 26)	R0 (none)
4124	0(4)-20mA 1.1	Output B	R0 (none)	R26 (relay 26)	R0 (none)
4125	0(4)-20mA 1.1	Enable	OFF	ON	OFF
4126	0(4)-20mA 1.1	Fail class	See description of fail classes		

4130 0-20 4-20mA 1.2

No.	Setting		Min. setting	Max. setting	Factory setting
4131	0(4)-20mA 1.2	Set point	4mA	20mA	10mA
4132	0(4)-20mA 1.2	Delay	0.0 s	100.0 s	5.0 s
4133	0(4)-20mA 1.2	Output A	R0 (none)	R26 (relay 26)	R0 (none)
4134	0(4)-20mA 1.2	Output B	R0 (none)	R26 (relay 26)	R0 (none)
4135	0(4)-20mA 1.2	Enable	OFF	ON	OFF
4136	0(4)-20mA 1.2	Fail class	See description of fail classes		

4250 0-20 4-20mA 2.1

No.	Setting		Min. setting	Max. setting	Factory setting
4251	0(4)-20mA 2.1	Set point	4mA	20mA	10mA
4252	0(4)-20mA 2.1	Delay	0.0 s	100.0 s	5.0 s
4253	0(4)-20mA 2.1	Output A	R0 (none)	R26 (relay 26)	R0 (none)
4254	0(4)-20mA 2.1	Output B	R0 (none)	R26 (relay 26)	R0 (none)
4255	0(4)-20mA 2.1	Enable	OFF	ON	OFF
4256	0(4)-20mA 2.1	Fail class	See description of fail classes		

4260 0-20 4-20mA 2.2

No.	Setting		Min. setting	Max. setting	Factory setting
4261	0(4)-20mA 2.2	Set point	4mA	20mA	10mA
4262	0(4)-20mA 2.2	Delay	0.0 s	100.0 s	5.0 s
4263	0(4)-20mA 2.2	Output A	R0 (none)	R26 (relay 26)	R0 (none)
4264	0(4)-20mA 2.2	Output B	R0 (none)	R26 (relay 26)	R0 (none)
4265	0(4)-20mA 2.2	Enable	OFF	ON	OFF
4266	0(4)-20mA 2.2	Fail class	See description of fail classes		

4380 0-20 4-20mA 3.1

No.	Setting		Min. setting	Max. setting	Factory setting
4381	0(4)-20mA 3.1	Set point	4mA	20mA	10mA
4382	0(4)-20mA 3.1	Delay	0.0 s	100.0 s	5.0 s
4383	0(4)-20mA 3.1	Output A	R0 (none)	R26 (relay 26)	R0 (none)
4384	0(4)-20mA 3.1	Output B	R0 (none)	R26 (relay 26)	R0 (none)
4385	0(4)-20mA 3.1	Enable	OFF	ON	OFF
4386	0(4)-20mA 3.1	Fail class	See description of fail classes		

4390 0-20 4-20mA 3.2

No.	Setting		Min. setting	Max. setting	Factory setting
4391	0(4)-20mA 3.2	Set point	4mA	20mA	10mA
4392	0(4)-20mA 3.2	Delay	0.0 s	100.0 s	5.0 s
4393	0(4)-20mA 3.2	Output A	R0 (none)	R26 (relay 26)	R0 (none)
4394	0(4)-20mA 3.2	Output B	R0 (none)	R26 (relay 26)	R0 (none)
4395	0(4)-20mA 3.2	Enable	OFF	ON	OFF
4396	0(4)-20mA 3.2	Fail class	See description of fail classes		

VDO inputs

4220 VDO fuel level input 1.1

No.	Setting		Min. setting	Max. setting	Factory setting
4221	Fuel level 1.1 (P3)	Set point	0%	100%	10%
4222	Fuel level 1.1 (P3)	Delay	0.0 s	100.0 s	5.0 s
4223	Fuel level 1.1	Output A	R0 (none)	R26 (relay 26)	R0 (none)
4224	Fuel level 1.1	Output B	R0 (none)	R26 (relay 26)	R0 (none)
4225	Fuel level 1.1	Enable	OFF	ON	OFF
4226	Fuel level 1.1	Fail class	See description of fail classes		

4230 VDO fuel level input 1.2

No.	Setting		Min. setting	Max. setting	Factory setting
4231	Fuel level 1.2 (P3)	Set point	0%	100%	99%
4232	Fuel level 1.2 (P3)	Delay	0.0 s	100.0 s	5.0 s
4233	Fuel level 1.2	Output A	R0 (none)	R26 (relay 26)	R0 (none)
4234	Fuel level 1.2	Output B	R0 (none)	R26 (relay 26)	R0 (none)
4235	Fuel level 1.2	Enable	OFF	ON	OFF
4236	Fuel level 1.2	Fail class	See description of fail classes		

4310 VDO oil press. input 2.1

No.	Setting (D)		Min. setting	Max. setting	Factory setting
4311	VDO 2.1	Set point	0.0 bar	10.0 bar	4.0 bar
4312	VDO 2.1	Delay	0.0 s	100.0 s	5.0 s
4313	VDO 2.1	Output A	R0 (none)	R26 (relay 26)	R0 (none)
4314	VDO 2.1	Output B	R0 (none)	R26 (relay 26)	R0 (none)
4315	VDO 2.1	Enable	OFF	ON	OFF
4316	VDO 2.1	Fail class	See description of fail classes		

4320 VDO oil press. input 2.2

No.	Setting (D)		Min. setting	Max. setting	Factory setting
4321	VDO 2.2	Set point	0.0 bar	10.0 bar	4.0 bar
4322	VDO 2.2	Delay	0.0 s	100.0 s	5.0 s
4323	VDO 2.2	Output A	R0 (none)	R26 (relay 26)	R0 (none)
4324	VDO 2.2	Output B	R0 (none)	R26 (relay 26)	R0 (none)
4325	VDO 2.2	Enable	OFF	ON	OFF
4326	VDO 2.2	Fail class	See description of fail classes		

4460 VDO water temp. input 3.1

No.	Setting		Min. setting	Max. setting	Factory setting
4461	VDO 3.1	Set point	0°C	150°C	95°C
4462	VDO 3.1	Delay	0.0 s	100.0 s	5.0 s
4463	VDO 3.1	Output A	R0 (none)	R26 (relay 26)	R0 (none)
4464	VDO 3.1	Output B	R0 (none)	R26 (relay 26)	R0 (none)
4465	VDO 3.1	Enable	OFF	ON	OFF
4466	VDO 3.1	Fail class	See description of fail classes		

4470 VDO water temp. input 3.2

No.	Setting		Min. setting	Max. setting	Factory setting
4471	VDO 3.2	Set point	0°C	150°C	95°C
4472	VDO 3.2	Delay	0.0 s	100.0 s	5.0 s
4473	VDO 3.2	Output A	R0 (none)	R26 (relay 26)	R0 (none)
4474	VDO 3.2	Output B	R0 (none)	R26 (relay 26)	R0 (none)
4475	VDO 3.2	Enable	OFF	ON	OFF
4476	VDO 3.2	Fail class	See description of fail classes		

4630 VDO low coolant temp. input 3.3

No.	Setting		Min. setting	Max. setting	Factory setting
4631	VDO 3.3	Set point	-50°C	50°C	10°C
4632	VDO 3.3	Delay	0.0 s	10.0 s	1.0 s
4633	VDO 3.3	Output A	R0 (none)	R26 (relay 26)	R0 (none)
4634	VDO 3.3	Output B	R0 (none)	R26 (relay 26)	R0 (none)
4635	VDO 3.3	Enable	OFF	ON	OFF
4636	VDO 3.3	Fail class	See description of fail classes		



VDO type: See functional description.

RPM input

4510 Overspeed 1 (RPM input)

No.	Setting		Min. setting	Max. setting	Factory setting
4511	Overspeed 1	Set point	0%	400%	160%
4512	Overspeed 1	Timer	0.2 s	100.0 s	15.0 s
4513	Overspeed 1	Relay output A	R0 (none)	R26 (relay 26)	R0 (none)
4514	Overspeed 1	Relay output B	R0 (none)	R26 (relay 26)	R0 (none)
4515	Overspeed 1	Enable	OFF	ON	OFF
4516	Overspeed 1	Fail class	See description of fail classes		

4520 Overspeed 2 (RPM input)

No.	Setting		Min. setting	Max. setting	Factory setting
4521	Overspeed 2	Set point	0%	400%	160%
4522	Overspeed 2	Timer	0.2 s	100.0 s	15.0 s
4523	Overspeed 2	Relay output A	R0 (none)	R26 (relay 26)	R0 (none)
4524	Overspeed 2	Relay output B	R0 (none)	R26 (relay 26)	R0 (none)
4525	Overspeed 2	Enable	OFF	ON	OFF
4526	Overspeed 2	Fail class	See description of fail classes		



Overspeed 1 and 2 are always active if enabled regardless of nominal setting. Thus it is possible to set two levels of overspeed.

4560 Hz/V failure

No.	Setting		Min. setting	Max. setting	Factory setting
4561	Hz/V failure*	Timer	1.0 s	99.0 s	30.0 s
4562	Hz/V failure	Relay output A	R0 (none)	R26 (relay 26)	R0 (none)
4563	Hz/V failure	Relay output B	R0 (none)	R26 (relay 26)	R0 (none)
4565	Hz/V failure	Enable	OFF	ON	ON
4566	Hz/V failure	Fail class	See description of fail classes		

When the frequency and voltage have not been OK for the adjusted delay time, a *Hz/V failure* alarm occurs, and output A and B activate.

4580 Stop failure

No.	Setting		Min. setting	Max. setting	Factory setting
4581	Stop failure*	Timer	10.0 s	120.0 s	30.0 s
4582	Stop failure	Relay output A	R0 (none)	R26 (relay 26)	R0 (none)
4583	Stop failure	Relay output B	R0 (none)	R26 (relay 26)	R0 (none)

If the engine has not stopped within the delay time, outputs A and B will activate and a *stop failure* alarm occurs.

4600 V-belt/RPM input failure

No.	Setting		Min. setting	Max. setting	Factory setting
4601	V-belt (P3)	Timer	0.0 s	10.0 s	1.0 s
4602	V-belt	Relay output A	R0 (none)	R26 (relay 26)	R0 (none)
4603	V-belt	Relay output B	R0 (none)	R26 (relay 26)	R0 (none)
4604	V-belt	Enable	OFF	ON	OFF
4605	V-belt	Fail class	See description of fail classes		



The V-belt failure is used on air-cooled engines to monitor that the V-belt driven cooling fan is operating properly. This alarm requires W input to be used in parallel with another running feedback at the same time. The status of both will be compared. If they do not match, a V-belt alarm will be activated.

4610 Charger gen.

No.	Setting		Min. setting	Max. setting	Factory setting
4611	Charger gen. (P3)	Timer	0.0 s	60.0 s	0.2 s
4612	Charger gen.	Relay output A	R0 (none)	R26 (relay 26)	R0 (none)
4613	Charger gen.	Relay output B	R0 (none)	R26 (relay 26)	R0 (none)
4614	Charger gen.	Enable	OFF	ON	OFF
4615	Charger gen.	Fail class	See description of fail classes		



This alarm requires D+ input to be used in parallel with another running feedback at the same time (binary input, tacho, generator voltage). The status of both will be compared. If they do not match, a charger gen. alarm will be activated.

4620 VDO fuel level input 1.3

No.	Setting		Min. setting	Max. setting	Factory setting
4621	Fuel level 1.3 (P3)	Set point	0%	100%	80%
4622	Fuel level 1.3 (P3)	Delay	0.0 s	100.0 s	5.0 s
4623	Fuel level 1.3	Output A	R0 (none)	R26 (relay 26)	R0 (none)
4624	Fuel level 1.3	Output B	R0 (none)	R26 (relay 26)	R0 (none)
4625	Fuel level 1.3	Enable	OFF	ON	OFF
4626	Fuel level 1.3	Fail class	See description of fail classes		

4950 Battery low 2

No.	Setting		Min. setting	Max. setting	Factory setting
4951	Battery low 2	Set point	6.0V	28.0V	15.0V
4952	Battery low 2	Timer	0.0 s	999.0 s	1.0 s
4953	Battery low 2	Relay output A	R0 (none)	R26 (relay 26)	R0 (none)
4954	Battery low 2	Relay output B	R0 (none)	R26 (relay 26)	R0 (none)
4955	Battery low 2	Enable	OFF	ON	ON

4960 Battery low 1

No.	Setting		Min. setting	Max. setting	Factory setting
4961	Battery low V*	Set point	6.0V	28.0V	16.0V
4962	Battery low V*	Timer	0.0 s	999.0 s	1.0 s
4963	Battery low V	Relay output A	R0 (none)	R26 (relay 26)	R0 (none)
4964	Battery low V	Relay output B	R0 (none)	R26 (relay 26)	R0 (none)
4965	Battery low V	Enable	OFF	ON	ON

4970 Battery high voltage

No.	Setting		Min. setting	Max. setting	Factory setting
4971	Battery high V*	Set point	15.0V	40.0V	28.0V
4972	Battery high V*	Timer	0.0 s	10.0 s	1.0 s
4973	Battery high V	Relay output A	R0 (none)	R26 (relay 26)	R0 (none)
4974	Battery high V	Relay output B	R0 (none)	R26 (relay 26)	R0 (none)
4975	Battery high V	Enable	OFF	ON	OFF

5000...5060 Relay functions

No.	Setting		First/min. setting	Second/max. setting	Factory setting
50X1	Relay X	Function	Alarm	Limit	Alarm
50X2	Relay X	Off delay	0.0 s	999.9 s	5.0 s



If option A is present, then parameter 5050 and 5060 are not available.

Alarm/Limit function of relays

Alarm relay function: When an alarm activates the relay, it is activated as long as the alarm is present and unacknowledged. If the Off delay is set different from 0.0 s, a short reset of the relay will take place when a new alarm appears.

Limit function: When an input activates the relay, no alarm message is displayed. After the condition activating this relay has returned to normal, the relay will deactivate when the Off delay has expired.



Relays used in M-logic strings must be set to limit function to work correct.

6000 Nominal settings 1

No.	Setting		Min. setting	Max. setting	Factory setting
6001	Nominal settings 1	Frequency	48.0Hz	62.0Hz	50.0Hz
6002	Nominal settings 1	Generator power	4kW	20000kW	480kW
6003	Nominal settings 1	Generator current	0A	9000A	787A
6004	Nominal settings 1	Generator volt.	50V	25000V	400V
6005	Nominal settings 1	Nom. RPM 1	0 RPM	4000 RPM	1500 RPM
6006	Nominal settings	Set			



Which set of nominal setting is used can be chosen in parameter 6006.

6010 Nominal settings 2

No.	Setting		Min. setting	Max. setting	Factory setting
6011	Nominal settings 2	Frequency	48.0Hz	62.0Hz	50.0Hz
6012	Nominal settings 2	Generator power	4kW	20000kW	480kW
6013	Nominal settings 2	Generator current	0A	9000A	787A
6014	Nominal settings 2	Generator volt.	50V	25000V	400V
6015	Nominal settings 2	Nom. RPM 2	0 RPM	4000 RPM	1500 RPM



The voltage set in nominal settings 1 and 2 is phase-to-phase values.

6020 Nominal settings 3 (1 ph)

No.	Setting		Min. setting	Max. setting	Factory setting
6021	Nominal settings 3	Frequency	48.0Hz	62.0Hz	50.0Hz
6022	Nominal settings 3	Generator power	4kW	20000kW	480kW
6023	Nominal settings 3	Generator current	0A	9000A	787A
6024	Nominal settings 3	Generator volt.	50V	25000V	230V
6025	Nominal settings 3	Nom. RPM 3	0 RPM	4000 RPM	1500 RPM

6030 Nominal settings 4 (split ph)

No.	Setting		Min. setting	Max. setting	Factory setting
6031	Nominal settings 4	Frequency	48.0Hz	62.0Hz	50.0Hz
6032	Nominal settings 4	Generator power	4kW	20000kW	480kW
6033	Nominal settings 4	Generator current	0A	9000A	787A
6034	Nominal settings 4	Generator volt.	50V	25000V	400V
6035	Nominal settings 4	Nom. RPM 4	0 RPM	4000 RPM	1500 RPM



Each nominal setting can be selected by parameter 6006, M-logic or by external communication.



The voltage set in nominal settings 4 is phase (L1) to phase (L2) values.

6040 Transformer generator

No.	Setting		Min. setting	Max. setting	Factory setting
6041	Transformer gen.	Primary	50V	25000V	440V
6042	Transformer gen.	Secondary	50V	480V	440V
6043	Transformer gen.	Current prim.	5A	9000A	1000A
6045	Transformer gen.	Current sec.	1A	5A	5A



If no voltage transformer is used, the setting 440/440V can be maintained.

6070 Gen-set mode

No.	Setting		Min. setting	Max. setting	Factory setting
6071	Gen-set mode	Setpoint	Island	Load take over	Island

6080 Language

No.	Setting		Setting	Factory setting
6081	Language	English	Master	Master
6082	Language	Selectable*	No 1	
6083	Language	Selectable*	No 2	
6084	Language	Selectable*	No 3	

*See chapter page 40 regarding language selection



The date and time can easily be synchronised with the laptop using the TPS 300 software or changed manual via display.

6100 Counter

No.	Setting		Min. setting	Max. setting	Factory setting
6101	Counter*	Running, hours	0	20000	0
6103	Counter*	GB operations	0	20000	0
6105	Counter*	Reset counter kWh	OFF	ON	OFF

6110 Service timer 1

No.	Setting		Min. setting	Second setting	Max. setting	Factory setting
6111	Service timer 1	Type	OFF	Counting down	Counting up	OFF
6112	Service timer 1*	Set point hours	1		10000	150
6113	Service timer 1*	Set point days	1		1000	365
6114	Service timer 1	Fail class	See description of fail classes			
6115	Service timer 1	Output A	Relay 0		Relay 5	Relay 0
6116	Service timer 1*	Reset	OFF		ON	OFF

6120 Service timer 2

No.	Setting		Min. setting	Second setting	Max. setting	Factory setting
6121	Service timer 2	Type	OFF	Counting down	Counting up	OFF
6122	Service timer 2*	Set point hours	1		10000	150
6123	Service timer 2*	Set point days	1		1000	365
6124	Service timer 2	Fail class	See description of fail classes			
6125	Service timer 2	Output A	Relay 0		Relay 5	Relay 0
6126	Service timer 2*	Reset	OFF		ON	OFF

6130 Alarm horn

No.	Setting		Min. setting	Max. setting	Factory setting
6131	Alarm horn*	Timer	0.0 s	990.0 s	20.0 s

According to factory setting the horn output will activate for 20 seconds when an alarm appears. If the timer setting is adjusted to 0, the horn relay will be activated continuously, until the reset alarm horn push-button is activated or the alarm is acknowledged.

6160 Run status

No.	Setting		Min. setting	Max. setting	Factory setting
6161	Run status	Timer	0.0 s	60.0 s	5.0 s
6162	Run status	Relay output A	R0 (none)	R26 (relay 26)	R0 (none)
6163	Run status	Relay output B	R0 (none)	R26 (relay 26)	R0 (none)
6164	Run status	Enable	OFF	ON	OFF

The running status detection has two purposes:

1. When the time delay period expires, all the alarms which have Enable selected to 'Not run status' will be activated.
2. An output relay can be selected, if one is available. In that case, the settings output A and output B must be set according to the desired relay. To avoid an unwanted display alarm, 'RUN STATUS ALARM', the function of this relay must be selected to 'Limit' function to avoid the alarm when the engine starts. Notice that both output A and output B must have the same settings, when the function of the relay is set only as limit switch.

6170 Tacho config.

No.	Setting		Min. setting	Max. setting	Factory setting
6173	Tacho config.	Set point	0 RPM	4000 RPM	400 RPM
6171	Tacho config.	Number of teeth	0 teeth	500 teeth	0 teeth



The tacho config. set point is used to deactivate the start relay. The number of teeth is used to configure the tacho input. The tacho input must be configured to 0 teeth when not in use. The tacho input accepts magnetic pick-up (direct connection) or NPN/PNP/charger generator W input. Refer to functional description for information. Note that the frequency range for the tacho input is 10Hz to 10000Hz.



The * indicates parameters that can be changed via the push-buttons/display.

6180 Starter

No.	Setting		Min. setting	Max. setting	Factory setting
6181	Starter (P1)	Start prepare	0.0 s	600.0 s	5.0 s
6183	Starter (P1)	Start ON time	1.0 s	180.0s	5.0 s
6184	Starter (P1)	Start OFF time	1.0 s	99.0 s	5.0 s



The settings “start prepare”, “start ON time” and “start OFF time” are the periods in which the start relay is activated.



The start prepare output can e.g. be used for prelubricating or preheating. The start relay output is for activating the engine starter. The start sequence can be activated manually by pressing the “START” push-button in Local (hand) mode.



If no output relay has been chosen as starter relay, the start and stop sequences (cooling down) will be ignored, and the MEC 310 will only operate as a safety stop device.

6190 Start attempts

No.	Setting		Min. setting	Max. setting	Factory setting
6191	Start attempts	Attempts	1	10	3
6192	Start attempts	Relay output A	R0 (none)	R26 (relay 26)	R0 (none)
6193	Start attempts	Relay output B	R0 (none)	R26 (relay 26)	R0 (none)

6210 Run/stop (cooling down)

No.	Setting		Min. setting	Max. setting	Factory setting
6211	Run/stop (P1)	Cooling down time	0.0 s	999.0 s	240.0 s
6212	Run/stop (P1)	Extended STOP	1.0 s	99.0 s	5.0 s
6213	Cool. down temp.	Cool down temp.	0°C	302°C	70°C
6214	Reference	Input for temp. ref.	VDO 3	EIC	VDO 3

Hz/V monitoring settings

6220 Hz/V OK

No.	Setting		Min. setting	Max. setting	Factory setting
6221	Hz/V OK*	Timer	1.0 s	99.0 s	5.0 s
6222	Hz/V OK*	Voltage	1%	70%	10%
6223	Hz/V OK*	Frequency	1Hz	20Hz	5Hz



The setting ranges refer to nominal setting (nominal voltage +/- setting %, nominal frequency +/- setting Hz).

6290 Idle mode

No.	Setting		Min. setting	Max. setting	Factory setting
6291	Idle mode	Enable	OFF	ON	OFF
6292	Idle mode	Timer	1.0 s	300.0 s	5.0 s
6293	Idle mode	Active	Man.	Man./aut.	Aut.

Idle mode can be controlled via a binary input. If this is selected, the idle mode remains for as long as the input is ON. If a binary input is not used, the idle mode can be selected to be active for manual or auto or both running modes.

- Both manual and auto: Select Man./Auto
- Manual only: Select Man.
- Auto only: Select Auto

6320 Engine heater on

No.	Setting		Min. setting	Max. setting	Factory setting
6321	External heater on	Set point	0 C/F	100 C/F	10 C/F

6330 Engine heater off

No.	Setting		Min. setting	Max. setting	Factory setting
6331	External heater off	Set point	0 C/F	100 C/F	20 C/F



In order to make the external heater function work, a relay must be designated to this function in the output settings.

6350 D+ input

No.	Setting		Min. setting	Max. setting	Factory setting
6351	D+ input (P3)	Timer	0.0 s	100.0 s	10.0 s
6352	D+ input	Relay output A	R0 (none)	R26 (relay 26)	R0 (none)
6353	D+ input	Enable	OFF	ON	OFF
6354	D+ input	NO/NC	NO	NC	NO



If the D+ input is selected to be ON, this will be used as a running feedback. The D+ output from the charge generator must be connected to the input terminal configured to this function. The terminal 9 (common for terminals 10-15) must be connected to +, otherwise the D+ input does not work.

6360 GB on water temp.

No.	Setting		Min. setting	Max. setting	Factory setting
6361	GB on water temp.	Set point	0 C/F	100 C/F	40 C/F
6362	GB on water temp.	Enable	OFF	ON	OFF

6550 Fuel pump logic

No.	Setting		Min. setting	Max. setting	Factory setting
6551	Fuel pump logic (P3)	Set point 1	0%	100%	20%
6552	Fuel pump logic (P3)	Set point 2	0%	100%	90%
6553	Fuel pump logic (P3)	Timer	0.1 s	300.0 s	60.0 s
6554	Fuel pump logic	Enable	OFF	ON	OFF



A relay must be configured to fuel pump in output settings.



10980 Config. input 1 must be set to VDO to activate the fuel pump logic.

6560 Cool-down timeout

No.	Setting		Min. setting	Max. setting	Factory setting
6561	Cool-down timeout	Timer	0.0 s	9999.0 s	900.0 s
6562	Cool-down timeout	Relay output A	R0 (none)	R26 (relay 26)	R0 (none)
6563	Cool-down timeout	Relay output B	R0 (none)	R26 (relay 26)	R0 (none)

6570 Oil press. run detection

No.	Setting		Min. setting	Max. setting	Factory setting
6571	Oil press. run detection	Set point	0 bar/PSI	150 bar/PSI	1 bar/PSI
6572	Oil press. run detection	Enable	OFF	ON	OFF



Parameter 6570 Oil pres. run detection makes it possible to use the oil pressure as a running feedback.

6700 Diode compensation

No.	Setting		Min. setting	Max. setting	Factory setting
6700	Diode compensation	Set point	0V	1V	0V



The parameter 6700 can add an offset to the supply voltage measurement displayed. This can be useful, if a diode is mounted in the supply connection.

6950 Parameter group 1

No.	Setting		Min. setting	Max. setting	Factory setting
6950	Parameter group 1	Enable	OFF	ON	OFF

6960 Parameter group 2

No.	Setting		Min. setting	Max. setting	Factory setting
6960	Parameter group 2	Enable	OFF	ON	OFF

6970 Parameter group 3

No.	Setting		Min. setting	Max. setting	Factory setting
6970	Parameter group 3	Enable	OFF	ON	OFF



If a parameter list is enabled, the parameters marked (PX) are available in the display parameter list.

6980 Sleep mode

No.	Setting		Min. setting	Max. setting	Factory setting
6981	Sleep	Timer	0 sec.	1800 sec.	600 sec.
6982	Sleep	ON/OFF	OFF	ON	OFF

The sleep mode is a standstill power save mode. If the engine is stopped and nothing has happened within the time setting, the unit will enter sleep mode, i.e. the most power consuming functions (e.g. display) are turned off. As soon as an event occurs (a button is activated, the input state changes), the sleep mode is ended.

7090 Simple test function

No.	Setting		Min. setting	Second setting	Max. setting	Factory setting
7091	Activation	Set point	Digital input	Button	Digital input or button	Button
7092	Timer	Timer	0.0 s	-	990.0 s	5.0 s
7093	Enable	Enable	OFF	-	ON	ON

6940 Alarm LED function

No.	Setting		Min. setting	Max. setting	Factory setting
6941	Alarm LED function	Customer	Red/Red (Warning/ Shutdown)	Amber/Red (Warning/ Shutdown)	Red/Red (Warning/ Shutdown)

7560 Engine I/F

No.	Setting		Min. setting	Max. setting	Factory setting
7561	Engine I/F	Engine type	OFF DDEC EMR JDEC Iveco Perkins Caterpillar Volvo Penta EMS Volvo Penta EMS 2 Scania EMS Scania EMS S6 MDEC 2000/4000 M.302 MDEC 2000/4000 M.303 MTU ADEC Cummins CM850 Generic J1939		OFF
7562	Engine I/F	Node CANopen ID	1	128	6
7563	Engine I/F	EIC Controls	on	off	on
7564	Engine I/F	EIC Auto View	on	off	on



Menu 7562 is only used when MTU ADEC is selected as engine type.

7570 EIC comm. error

No.	Setting		Min. setting	Max. setting	Factory setting
7571	EI comm. error	Delay	0.0 s	100.0 s	0.0 s
7572	EI comm. error	Relay output A	Not used	Option dependent	Not used
7573	EI comm. error	Relay output B	Not used		Not used
7574	EI comm. error	Enable	OFF	ON	OFF
7575	EI comm. error	Fail class	Unit dependent		Warning



Please choose MDEC 2000/4000 M.303, when M.201 or M.304 is required.

7580 EIC warning

No.	Setting		Min. setting	Max. setting	Factory setting
7581	EIC warning	Delay	0.0 s	100.0 s	0.0 s
7582	EIC warning	Relay output A	Not used	Option dependent	Not used
7583	EIC warning	Relay output B	Not used		Not used
7584	EIC warning	Enable	OFF	ON	OFF
7585	EIC warning	Fail class	Unit dependent		Warning

7590 EIC shutdown

No.	Setting		Min. setting	Max. setting	Factory setting
7591	EIC shutdown	Delay	0.0 s	100.0 s	0.0 s
7592	EIC shutdown	Relay output A	Not used	Option dependent	Not used
7593	EIC shutdown	Relay output B	Not used		Not used
7594	EIC shutdown	Enable	OFF	ON	OFF
7595	EIC shutdown	Fail class	Unit dependent		Shutdown

7600 EIC overspeed

No.	Setting		Min. setting	Max. setting	Factory setting
7601	EIC overspeed	Set point	0 %	400 %	107 %
7602	EIC overspeed	Delay	0.0 s	100.0 s	2.0 s
7603	EIC overspeed	Relay output A	Not used	Option dependent	Not used
7604	EIC overspeed	Relay output B	Not used		Not used
7605	EIC overspeed	Enable	OFF	ON	OFF
7606	EIC overspeed	Fail class	Unit dependent		Warning

7610 EIC coolant t. 1

No.	Setting		Min. setting	Max. setting	Factory setting
7611	EIC coolant t. 1	Set point	-40 deg.	210 deg.	100 deg.
7612	EIC coolant t. 1	Delay	0.0 s	100.0 s	5.0 s
7613	EIC coolant t. 1	Relay output A	Not used	Option dependent	Not used
7614	EIC coolant t. 1	Relay output B	Not used		Not used
7615	EIC coolant t. 1	Enable	OFF	ON	OFF
7616	EIC coolant t. 1	Fail class	Unit dependent		Warning

7620 EIC coolant t. 2

No.	Setting		Min. setting	Max. setting	Factory setting
7621	EIC coolant t. 2	Set point	-40 deg.	210 deg.	110 deg.
7622	EIC coolant t. 2	Delay	0.0 s	100.0 s	5.0 s
7623	EIC coolant t. 2	Relay output A	Not used	Option dependent	Not used
7624	EIC coolant t. 2	Relay output B	Not used		Not used
7625	EIC coolant t. 2	Enable	OFF	ON	OFF
7626	EIC coolant t. 2	Fail class	Unit dependent		Warning

7630 EIC oil press. 1

No.	Setting		Min. setting	Max. setting	Factory setting
7631	EIC oil press. 1	Set point	0.0 bar	10.0 bar	2.0 bar
7632	EIC oil press. 1	Delay	0.0 s	100.0 s	5.0 s
7633	EIC oil press. 1	Relay output A	Not used	Option dependent	Not used
7634	EIC oil press. 1	Relay output B	Not used		Not used
7635	EIC oil press. 1	Enable	OFF	ON	OFF
7636	EIC oil press. 1	Fail class	Unit dependent		Warning

7640 EIC oil press. 2

No.	Setting		Min. setting	Max. setting	Factory setting
7641	EIC oil press. 2	Set point	0.0 bar	10.0 bar	1.0 bar
7642	EIC oil press. 2	Delay	0.0 s	100.0 s	5.0 s
7643	EIC oil press. 2	Relay output A	Not used	Option dependent	Not used
7644	EIC oil press. 2	Relay output B	Not used		Not used
7645	EIC oil press. 2	Enable	OFF	ON	OFF
7646	EIC oil press. 2	Fail class	Unit dependent		Warning

7650 EIC oil Temp. 1

No.	Setting		Min. setting	Max. setting	Factory setting
7651	EIC oil temp. 1	Set point	0 C	300 C	40 C
7652	EIC oil temp. 1	Delay	0.0 s	100.0 s	5.0 s
7653	EIC oil temp. 1	Relay output A	Not used	Option dependent	Not used
7654	EIC oil temp. 1	Relay output B	Not used		Not used
7655	EIC oil temp. 1	Enable	OFF	ON	OFF
7656	EIC oil temp. 1	Fail class	Unit dependent		Warning

7660 EIC oil Temp. 2

No.	Setting		Min. setting	Max. setting	Factory setting
7661	EIC oil temp. 2	Set point	0 C	300 C	40 C
7662	EIC oil temp. 2	Delay	0.0 s	100.0 s	5.0 s
7663	EIC oil temp. 2	Relay output A	Not used	Option dependent	Not used
7664	EIC oil temp. 2	Relay output B	Not used		Not used
7665	EIC oil temp. 2	Enable	OFF	ON	OFF
7666	EIC oil temp. 2	Fail class	Unit dependent		Warning

9110 Password

No.	Setting		Min. setting	Max. setting	Factory setting
9116	Password	Customer	0	9999	2000
9117	Password	Service	0	9999	2001

User password

If you forget the password, contact Thomson Technology for details.

10000 Cmd.1 timer/start/stop

No.	Setting	Min. setting	Max. setting	Factory setting
10001	Cmd.1 timer/start/stop Setpoint	timer M-logic	Stop	timer M-logic
10002	Cmd.1 timer/start/stop Enable	OFF	ON	OFF

10010 Cmd.1 day(s)

No.	Setting	Setting	Factory setting
10010	Cmd.1 day(s)	MO	
		TU	
		WE	
		TH	
		FR	
		SA	
		SU	
		MO-TU-WE-TH	
		MO-TU-WE-TH-FR	
		SA-SU	
		MO-TU-WE-TH-FR-SA-SU	X

10020 Cmd.1 hour

No.	Setting	Min. setting	Max. setting	Factory setting
10020	Cmd.1 hour	0	23	10

10030 Cmd.1 min

No.	Setting	Min. setting	Max. setting	Factory setting
10030	Cmd.1 min	0	59	0



Same structure is repeated for day 2-8, settings 10040-10310.

10320-10370 GSM pin code and dial-up numbers

No.	Setting	Min. setting	Max. setting	Factory setting
10320	GSM GSM pin code	0	9999	0
10331	GSM SMS telephone no.	0	+99999999999999	+4511223344
10332	GSM Enable	OFF	ON	OFF
10341	GSM SMS telephone no.	0	+99999999999999	+4511223344
10342	GSM Enable	OFF	ON	OFF
10351	GSM SMS telephone no.	0	+99999999999999	+4511223344
10352	GSM Enable	OFF	ON	OFF
10361	GSM SMS telephone no.	0	+99999999999999	+4511223344
10362	GSM Enable	OFF	ON	OFF
10371	GSM SMS telephone no.	0	+99999999999999	+4511223344
10372	GSM Enable	OFF	ON	OFF



A telephone number set to 0 means not used. The prefix + and country code must always be entered. E.g. +1 for Canada.

10460-10620 Fuel level config. sensor

No.	Setting		Min. setting	Max. setting	Factory setting
10460	Fuel level type	Type	1	3	1
10470	VDO 1	Fuel level Input 1	0 ohm	180 ohm	0 ohm
10480	VDO 1	Fuel level Output 1	0%	150%	40%
10490	VDO 1	Fuel level Input 2	0 ohm	180 ohm	40 ohm
10500	VDO 1	Fuel level Output 2	0%	150%	50%
10510	VDO 1	Fuel level Input 3	0 ohm	180 ohm	50 ohm
10520	VDO 1	Fuel level Output 3	0%	150%	60%
10530	VDO 1	Fuel level Input 4	0 ohm	180 ohm	60 ohm
10540	VDO 1	Fuel level Output 4	0%	150%	80%
10550	VDO 1	Fuel level Input 5	0 ohm	180 ohm	70 ohm
10560	VDO 1	Fuel level Output 5	0%	150%	100%
10570	VDO 1	Fuel level Input 6	0 ohm	180 ohm	80 ohm
10580	VDO 1	Fuel level Output 6	0%	150%	110%
10590	VDO 1	Fuel level Input 7	0 ohm	180 ohm	90 ohm
10600	VDO 1	Fuel level Output 7	0%	150%	90%
10610	VDO 1	Fuel level Input 8	0 ohm	180 ohm	100 ohm
10620	VDO 1	Fuel level Output 8	0%	150%	120%

10630-10790 Oil pressure config. sensor

No.	Setting		Min. setting	Max. setting	Factory setting
10630	Oil pressure type	Type	1	4	1
10640	VDO 2	Oil pressure Input 1	0 ohm	240 ohm	30 ohm
10650	VDO 2	Oil pressure Output 1	0.0 bar	15.0 bar	4.0 bar
10660	VDO 2	Oil pressure Input 2	0 ohm	240 ohm	60 ohm
10670	VDO 2	Oil pressure Output 2	0.0 bar	15.0 bar	5.0 bar
10680	VDO 2	Oil pressure Input 3	0 ohm	240 ohm	90 ohm
10690	VDO 2	Oil pressure Output 3	0.0 bar	15.0 bar	6.0 bar
10700	VDO 2	Oil pressure Input 4	0 ohm	240 ohm	120 ohm
10710	VDO 2	Oil pressure Output 4	0.0 bar	15.0 bar	8.0 bar
10720	VDO 2	Oil pressure Input 5	0 ohm	240 ohm	150 ohm
10730	VDO 2	Oil pressure Output 5	0.0 bar	15.0 bar	10.0 bar
10740	VDO 2	Oil pressure Input 6	0 ohm	240 ohm	180 ohm
10750	VDO 2	Oil pressure Output 6	0.0 bar	15.0 bar	11.0 bar
10760	VDO 2	Oil pressure Input 7	0 ohm	240 ohm	210 ohm
10770	VDO 2	Oil pressure Output 7	0.0 bar	15.0 bar	11.5 bar
10780	VDO 2	Oil pressure Input 8	0 ohm	240 ohm	240 ohm
10790	VDO 2	Oil pressure Output 8	0.0 bar	15.0 bar	15.0 bar

10800-10950 Water temp. config. sensor

No.	Setting		Min. setting	Max. setting	Factory setting
10800	VDO	Type	1	5	1
10810	VDO 3	Water temp. Input 1	0 ohm	2500 ohm	0 ohm
10820	VDO 3	Water temp. Output 1	0	150	0°C
10830	VDO 3	Water temp. Input 2	0 ohm	2500 ohm	40 ohm
10840	VDO 3	Water temp. Output 2	0	150	40°C
10850	VDO 3	Water temp. Input 3	0 ohm	2500 ohm	60 ohm
10860	VDO 3	Water temp. Output 3	0	150	60°C
10870	VDO 3	Water temp. Input 4	0 ohm	2500 ohm	80 ohm
10880	VDO 3	Water temp. Output 4	0	150	80°C
10890	VDO 3	Water temp. Input 5	0 ohm	2500 ohm	90 ohm
10900	VDO 3	Water temp. Output 5	0	150	90°C
10910	VDO 3	Water temp. Input 6	0 ohm	2500 ohm	100 ohm
10920	VDO 3	Water temp. Output 6	0	150	100°C
10930	VDO 3	Water temp. Input 7	0 ohm	2500 ohm	120 ohm
10940	VDO 3	Water temp. Output 7	0	150	120°C
10950	VDO 3	Water temp. Input 8	0 ohm	2500 ohm	150 ohm
10960	VDO 3	Water temp. Output 8	0	150	150°C

10970-11000 Engineering units

No.	Setting		Min. setting	Max. setting	Factory setting
10971	Unit	Set point	C/bar	F/bar	C/bar

10980 Configurable input selection

No.	Setting		Min. setting	Max. setting	Factory setting
10980	Conf inp 1	Set point	VDO	Binary	VDO
10990	Conf inp 2	Set point	VDO	Binary	VDO
11000	Conf inp 3	Set point	VDO	Binary	VDO

Possible selections:

- VDO
- 4...20mA
- 0...20mA
- Binary

Thomson Technology reserves the right to change any of the above.