



MEC 20

MICROPROCESSOR ENGINE/GENERATOR CONTROLLER

**(WITH REMOTE COMMUNICATION, EXPANSION OUTPUT MODULE &
EAP 110 REMOTE ANNUNCIATOR OPTIONS)**

**INSTALLATION, OPERATING &
SERVICE MANUAL**

Software Version 1.81

PM047 Rev 12 03/03/04

CONTENTS

1.	INTRODUCTION	1
1.1.	PRODUCT REVISION HISTORY	1
1.2.	GENERAL DESCRIPTION	3
2.	INSTALLATION	5
2.1.	GENERAL INFORMATION	5
2.2.	BATTERY SUPPLY INPUT	5
2.3.	SPEED SENSING INPUT	6
2.4.	DC VOLTAGE INPUTS	7
2.5.	AC VOLTAGE INPUT	7
2.6.	AC CURRENT INPUT	8
2.7.	OUTPUTS	9
2.8.	EXTERNAL PANEL CONTROL WIRING	9
2.9.	REMOTE START CONTACT FIELD WIRING	10
2.10.	REMOTE COMMUNICATION WIRING	10
2.11.	EXPANSION OUTPUT MODULE LOCATION/INSTALLATION	11
2.12.	MEC MOUNTING LOCATION/INSTALLATION	12
2.13.	FACEPLATE MOUNTING DIMENSIONS	13
2.14.	MEC 20 ASSEMBLY - SIDE VIEW	13
2.15.	DIELECTRIC TESTING	14
3.	DESCRIPTION	15

3.1.	LEXAN FACEPLATE	15
3.2.	PRINTED CIRCUIT BOARD	17
4.	FAULT CIRCUIT DESCRIPTIONS	19
4.1.	MEC 20 FUNCTIONAL BLOCK DIAGRAM	20
4.2.	INTERNAL FAULT CIRCUITS	21
4.3.	DIGITAL FAULT INPUT CIRCUITS	22
4.4.	ANALOG FAULT INPUT CIRCUITS	24
5.	CONTROL OUTPUT CONTACT DESCRIPTIONS	29
5.1.	RUN, CRANK, COMMON FAIL OUTPUT CONTACTS	29
5.2.	PROGRAMMABLE OUTPUT CONTACTS	30
6.	REMOTE COMMUNICATION OPTION	34
7.	EXPANSION OUTPUT MODULE OPTION	38
8.	EAP 110 REMOTE ANNUNCIATOR OPTION	41
9.	OPERATING INSTRUCTIONS	42
9.1.	MEC 20 POWER-UP OPERATION SEQUENCE	42
9.2.	MEC 20 DISPLAY MENUS	42
9.3.	SEQUENCE OF OPERATION	50
9.4.	CONTROL PUSH-BUTTONS	57
10.	PROGRAMMING INSTRUCTIONS	59
10.1.	SECURITY PASSWORDS	59

10.2.	BASIC PROGRAMMING OPERATION	60
10.3.	MAIN PROGRAMMING MENU	61
10.4.	ANALOG FAULT PROGRAMMING MENU	69
10.5.	DIGITAL FAULT PROGRAMMING MENU	70
10.6.	CALIBRATION MENU	72
11.	PROGRAMMING SHEETS	83
11.1.	SUMMARY CONFIGURATION DATA SHEET	83
11.2.	MAIN CONFIGURATION	84
11.3.	ANALOG FAULT PROGRAMMING MENU	87
11.4.	DIGITAL FAULT PROGRAMMING MENU	88
11.5.	CALIBRATION MENU	89
12.	SPECIFICATIONS	90
13.	CONNECTION DIAGRAM	91
14.	TROUBLE SHOOTING	92
15.	NOTES	95

1. INTRODUCTION

1.1. PRODUCT REVISION HISTORY

The following information provides an historical summary of changes made to this product since the original release.

1.1.1. Software Version

<p>1.81 03/03/04</p>	<ul style="list-style-type: none"> ❑ Changed Oil Pressure Sender Manufacturer requiring revised pressure/resistance calibration data <p>New Oil Pressure Sender Thomson p/n-003654, Manufacturer-Datcon, p/n 102227.</p> <p>Discontinued Oil Pressure Sender Thomson p/n-000772, Manufacturer- Isspro, p/n R9279C</p> <p>Note: The oil pressure senders are <u>not</u> interchangeable with the software versions.</p>
<p>1.8 02/09/09</p>	<ul style="list-style-type: none"> ❑ Added Programmable Output Feature “EPS Supplying Load” ❑ Added Digital Input Feature “No-Load Test” ❑ Added New Digital Fault Names <ul style="list-style-type: none"> Basin Rupture ATS in Bypass Fuel Leak Vent Damper Fail High Fuel Level Low Fuel Press Bat Charger Fail Fail to Sync HighIntkManfTemp ❑ Added Independent Programming features for AMF Outputs ❑ Added references for EAP 110 Remote Annunciator ❑ Misc. Display & Menu changes

<p>1.7 02/02/15</p>	<p>Key changes implemented as follows:</p> <ul style="list-style-type: none"> • Auto Mains Failure (AMF) logic with new timers, control outputs and display features • Line to Neutral AC Voltage Display on 3 Phase 4 Wire Systems (neutral connection required) • Analog Shutdown Capability from Oil Pressure and Temperature Senders • Expanded oil pressure operation up to 150 PSI (was 100 PSI) • Single Point Calibration for Oil Pressure/engine temperature sender inputs (simplified calibration, field calibration is now mandatory) • Programmable Output features now expanded to map to every available fault circuit <p>Add new Programmable Output features Engine Ready & Engine Run (Fuel)</p> <p>There were also minor changes that are reflected in the manual.</p>
<p>1.6 01/07/18</p>	<p>Added Ready to load programmable output and new Isspro Oil Pressure sender curves; increased standard digital & analog fault features.</p>
<p>1.5 00/09/20</p>	<p>Added kVA metering.</p>
<p>1.4 99/12/09</p>	<p>Added new digital faults labels and blank selections.</p>
<p>1.3 98/02/09</p>	<p>New version with communication features, expansion relay module capability, deletion of “horn” programming, deletion of cooldown shutdown programmability, deletion of “common fail” programmability and revised password number.</p>
<p>1.2 97/06/04</p>	<p>Original version.</p>

1.1.2. Operating & Service Manual Version

<p>Rev 12 03/03/04</p>	<p>Changed Oil pressure/resistance calibration data and new software version 1.81.</p>
<p>Rev 11 02/09/09</p>	<p>Added descriptive information for new software version 1.8</p>

Rev 10 02/02/15	Added descriptive information for new software version 1.7
Rev 9 01/10/17	Clarification of faults required for C282 or NFPA 110.
Rev 8 01/07/18	Addition of "Static Precaution"; deletion of calibration jumpers to requiring external calibration resistors/potentiometers; standard fault circuits increase from 12 to 28; Ready status changes to "Ready to Load"; changes in temperature and pressure calibrations; extended temperature ratings.
Rev 7 00/12/01	Minor text changes.
Rev 6 00/10/06	Added KVA metering feature.
Rev 5 00/04/06	Changes made to digital fault labels.
Rev 4 99/02/01	Remote communication wiring changes; multiple controllers that can be connected changes from 5 to 10.
Rev 3 98/05/08	Corrected minor errors.
Rev 2 98/02/18	New version with communication features; expansion relay module capability and revised password number.
Rev 1 98/01/22	Corrected minor errors.
Rev 0 97/06/04	Original release.

Contact Thomson Technology, to obtain applicable instruction manuals. Soft copy of most current version is available at www.thomsontechnology.com.

1.2. GENERAL DESCRIPTION

The Thomson Technology MEC 20 Microprocessor-based Engine/Generator Controller utilizes the latest advancements in microprocessor design technology for the control and monitoring of engine-generator sets. The MEC 20 provides a comprehensive array of operational, protection and display features for automatically controlling an engine/generator set. All standard and optional features of the MEC 20 are configurable from the front panel LCD display and are security password protected. The LCD display screen prompts are in plain English, providing a user-friendly operator interface with many display options available. The microprocessor design provides high accuracy for all voltage monitoring, current monitoring and timing functions as well as providing many

standard features which were previously only available as expensive add-on optional features.

The MEC 20 provides the following advanced features:

- Up to 28 alarm/shutdown fault circuits utilizing analog and digital inputs.
- Standard model meets or exceeds CSA C282, NFPA 110 Level 1 generator set control requirements.
- RS 422 remote communication port.
- Expansion output module communication port for individual output fault contact capability.
- Backlit LCD display screen with alpha-numeric readout for display and programming.
- Digital 3-phase voltage, 3-phase current, KVA and frequency metering for generator output.
- Non-volatile memory retains logic and set points if control power is lost.
- Direct 3-phase voltage sensing inputs on generator supply from 120Vac up to 600Vac (nominal).
- Security password-protected programming levels.
- Self diagnostic features continuously verify processing, I/O and memory circuits.
- Superior EMI/RFI noise immunity and surge performance features as per IEEE C62.41 requirements.
- Dual microprocessor design provides independent speed sensing circuitry for higher performance.



CAUTION

contents subject to damage by
STATIC ELECTRICITY

This equipment contains static-sensitive parts. Please observe the following anti-static precautions at all times when handling this equipment. Failure to observe these precautions may cause equipment failure and/or damage.

- Discharge body static charge before handling the equipment (contact a grounded surface and maintain contact while handling the equipment, a grounded wrist strap can/should also be utilized).

- Do not touch any components on the printed circuit board with your hands or any other conductive equipment.
- Do not place the equipment on or near materials such as Styrofoam, plastic and vinyl. Place the equipment on grounded surfaces and only use an anti-static bag for transporting the equipment.

2. INSTALLATION

2.1. GENERAL INFORMATION

NOTE:

Installations should be done according to all applicable electrical regulation codes as required.

The following installation guidelines are provided for general information only pertaining to typical site installations. For specific site installation information, consult Thomson Technology as required. **Note:** Factory installations of TTI supplied control panels that have been tested and proven may deviate from these recommendations.

CAUTION!!!

All installation and/or service work performed must be done by qualified personnel only. Failure to do so may cause personal injury or death.

2.2. BATTERY SUPPLY INPUT

The MEC 20 can operate on any battery supply from 10 to 30 volts DC. The battery DC negative or common conductor must be grounded to the main generator-set frame ground. The MEC 20 is internally protected by a solid state type fuse that protects it from inadvertent shorts on the output terminals. The solid state fuse will automatically reset when the overcurrent condition is removed. Wiring from the engine cranking battery to the control panel should conform to the following guidelines to avoid possible controller malfunction and/or damage.

- 2.2.1. Avoid wiring from the engine starter terminals - wiring should go directly from the battery terminals to the engine control panel (to avoid voltage drop in the starter cables and starter motor commutator noise). **Note:** Unit mounted control panels with short wiring runs may utilize connections from the starter terminals provided that the specific application is tested satisfactorily.

CAUTION!!!

The battery charger must be turned off before battery cables are removed from the battery (i.e. for servicing). Failure to do so may subject the control panel to an overvoltage condition in which damage may result.

- 2.2.2. Wiring from battery to engine control panel should be two - #14 AWG (2.5mm²) wires (i.e. do not use the engine block as one of the common conductors).
- 2.2.3. Under noisy environments (i.e. gas engines with high voltage ignitions, etc.), wiring from battery should be a twisted pair of #14 AWG (2.5mm²) wires.

2.3. SPEED SENSING INPUT

Field wiring of the speed sensing signal wires should conform to the following guidelines to avoid possible controller malfunction and/or damage:

- 2.3.1. Wiring from magnetic pickup must utilize a 2 conductor shielded/twisted cable. The drain (shield) wire must be connected at the control panel end only.
- 2.3.2. Magnetic pickup voltage at cranking speed must be greater than 3.0VAC. At nominal speed, magnetic pickup voltage should be between 3.0 and 5VAC.
- 2.3.3. A single dedicated magnetic pickup is recommended for connection to the speed sensing input terminals. **Note:** One common magnetic pickup may be utilized for the system provided specific test measurements are done with the equipment installed (i.e. mag pickup voltage levels meet the required levels).

2.4. DC VOLTAGE INPUTS

All DC voltage inputs to the MEC 20 are optically isolated and filtered for protection from noise spikes and transients. Input wiring must be routed so that it is not near electrically "noisy" wiring such as ignition, starter wires or main AC power conductors. All contacts must be "dry" (i.e. non-powered) and one side must be connected to the common DC negative conductor.

2.5. AC VOLTAGE INPUT

The MEC 20 can accept direct AC voltage input from 120-600Vac (nominal). **Note:** Direct input voltage sensing can only be used when the generator utilizes a single phase 3 wire or 3 phase, 4 wire distribution system with a solidly grounded neutral conductor. For 3 phase 3 wire systems (i.e. no neutral) or high voltage systems, potential transformers must be used. Refer to FIGURES #1 - 4 for voltage sensing connections. To display generator line to neutral voltage in a 3 phase 4 wire system, the neutral must be connected as shown.

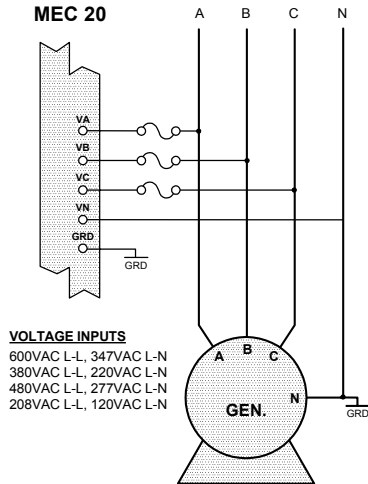

FIGURE #1
 3Ø, 4W 208/380/480/600VAC DIRECT SENSING
 SOLIDLY GROUNDED NEUTRAL SYSTEM

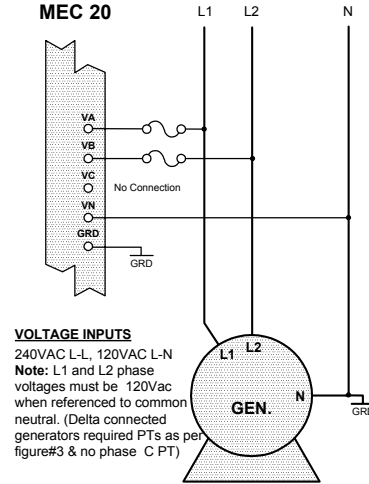

FIGURE #2
 1Ø, 3W 120/240VAC DIRECT SENSING
 SOLIDLY GROUNDED NEUTRAL SYSTEM

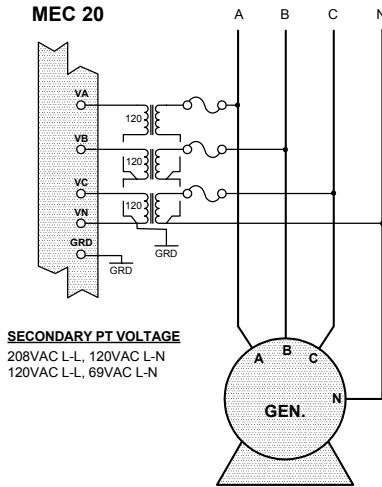

FIGURE #3
 3Ø, 4W WYE PT's

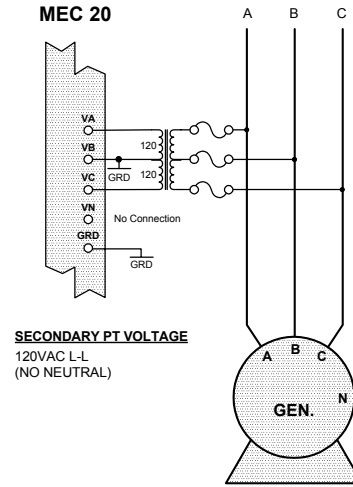

FIGURE #4
 3Ø, 3W DELTA PT's

G:\ENGINEER\PRODUCTS\MEC20\MEC20_08.VSD REV. 2 02/02/22

2.6. AC CURRENT INPUT

Current transformers (CT's) must be used to supply the MEC 20 current inputs. CT polarity is not critical for correct circuit operation. **Note:** The CT secondary common conductors must be externally grounded for correct operation. CT's must be rated for a minimum of 1.5VA output at the specified accuracy.

CAUTION!!!

When installing or performing any service work on CT circuits, always de-energize the system before proceeding with any work. Never open circuit an energized CT as extreme high voltages may result which may cause serious injury or death.

2.7. OUTPUTS

All outputs from the MEC 20 are relay driven contacts. Relay contacts have a 10A/240Vac resistive, 8A/24Vdc (3 Amp inductive 0.4pf), rating and are isolated Form A & Form C types. Interposing relays are recommended between the MEC 20 outputs and end devices to prevent internal damage due to possible excessive current draw and/or damage should an external fault occur. **Note:** These outputs will require external overcurrent protection (Maximum 10 Amp).

The use of AC or DC operated solenoids or relays in control systems can sometimes cause high voltage spikes on the DC power supply, which may cause electronic devices to fail. Transient suppression devices are recommended for all inductive devices sharing wiring or if physically located near engine/generator control panels. For DC operated relays or solenoids, use a suitably rated counter EMF Diode (or commonly known as “freewheeling” diode). For AC operated relays or solenoids, use a suitably rated metal oxide varistor (MOV) or capacitor/resistor suppressor.

2.8. EXTERNAL PANEL CONTROL WIRING

As a minimum, all control wiring shall conform to the local regulatory authority on electrical installations. Specific wire sizes for typical circuits[®] (of distances up to 100ft (30m)[®]) are as follows:

- | | |
|---|---|
| 2.8.1. Battery Control Power | #14 AWG (2.5mm ²) |
| 2.8.2. Engine Alarm/Shutdown Contacts | #16 AWG (1.5mm ²) |
| 2.8.3. Remote Start Contact for Transfer Switch | #14 AWG (2.5mm ²) |
| 2.8.4. Crank & Preheat Output Wiring | #14 AWG (2.5mm ²) (To pilot relays) |
| 2.8.5. Speed Sensing Wiring | #16 AWG (1.5mm ²) 2
Conductor Shielded Cable |
| 2.8.6. Metering Voltage Inputs | #16 AWG (1.5mm ²) |

2.8.7. Metering Current Inputs (from CT's) #14 AWG (2.5mm²)

• For distances exceeding 100 Ft. (30m) consult TTI.

• For unit mounted control panels, wire sizes may be reduced to the next smallest wire size available.

2.9. REMOTE START CONTACT FIELD WIRING

Field wiring of a remote start contact from a transfer switch to a control panel should conform to the following guidelines to avoid possible controller malfunction and/or damage.

2.9.1. Remote start contact wires (2 - #14 AWG (2.5mm²)) should be run in a separate conduit.

2.9.2. Avoid wiring near AC power cables to prevent pick-up of induced voltages.

2.9.3. An interposing relay may be required if field wiring distance is excessively long (i.e. greater than 100 feet (30m) and/or if a remote contact has a resistance of greater than 5.0 ohms.

2.9.4. The remote start contact must be voltage free (i.e. dry contact). The use of a "powered" contact will damage the engine controller.

2.10. REMOTE COMMUNICATION WIRING

All interconnecting wiring to/from the MEC 20 engine/generator controller communication port shall utilize #22 AWG (min.) 8 conductor, twisted, shielded cable with RJ45 connectors. The drain (shield) wire must be connected at the MEC 20 controller end only. Refer to *Section 6* for further information.

Communication cable from the controllers' com port must be suitably routed to protect it from sources of electrical interference. Guidelines for protection against possible electrical interference are as follows:

- Use high quality, 8 conductor shielded cable only with drain wire grounded at the controller end only.
- Route the communication cable at least 3 M (10") away from sources of electrical noise such as variable speed motor drives, high voltage power conductors, UPS systems, transformers, rectifiers etc.
- Use separate, dedicated conduit runs for all communication cables. Do not tightly bundle communication cables together in the conduit. Conduit

should be ferromagnetic type near sources of possible electrical interference. The entire length of conduit should be grounded to building earth ground.

- When communication cables must cross over low or high voltage AC power conductors, the communication cables must cross at right angles and not in parallel with the conductors.

For additional information on protection against electrical interference, contact TTI factory.

2.11. EXPANSION OUTPUT MODULE LOCATION/INSTALLATION

The expansion module(s) are to be mounted inside a control panel using four screws with stand-offs provided. The expansion module must be mounted within 300 metres (1000 feet) wiring distance from the MEC 20 using an 8 conductor shielded cable provided with the module. The communication cable must not be bundled together with other control wiring inside the panel. Mounting dimensions for the expansion output module are shown in FIGURE #5.

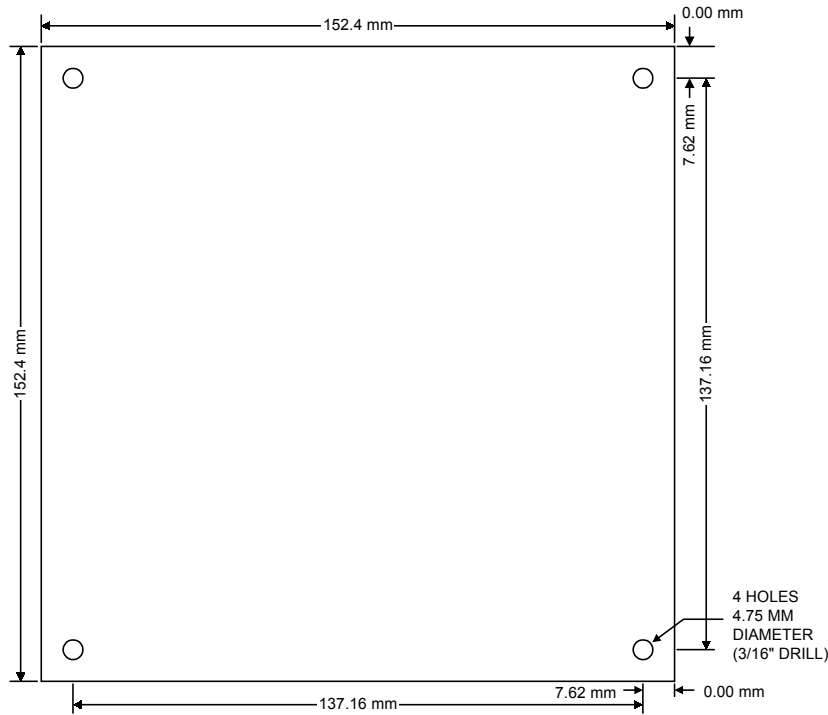

FIGURE #5: MEC 20 EXPANSION MODULE MOUNTING DIMENSIONS

G:\ENGINEER\PRODUCTS\MEC20\MEC20_14.VSD
DRAWING SCALE: 75:1

2.12. MEC MOUNTING LOCATION/INSTALLATION

The MEC 20 Engine-generator controller is designed for mounting directly onto a control panel door. Considerations should be given for the following:

- The controller should be installed in a dirt free, dry location away from extreme heat sources.
- The LCD window should be installed at an optimum height for operator viewing.
- Adequate space should be provided around the rear of the MEC 20 circuit board for control wiring.
- Verify that the intended AC voltage input to the controller does not exceed the maximum allowable level on the control panel door as per the applicable control panel certification standard.

The MEC 20 controller can be installed onto a door of a control panel using one of the following methods:

- The first method requires a special door cutout for the LCD display and LED's as shown in FIGURE #6. This mounting method requires the lexan faceplate to be mounted directly onto the door of the control panel. The controller must be disassembled to mount on the door, then re-assembled. Refer to FIGURE #7 for correct assembly location of all parts.
- The second method of controller mounting requires a factory supplied adapter faceplate as shown in FIGURE #8. This method only requires a single large rectangular hole to be cut out of the door as shown in FIGURE #9.

2.13. FACEPLATE MOUNTING DIMENSIONS

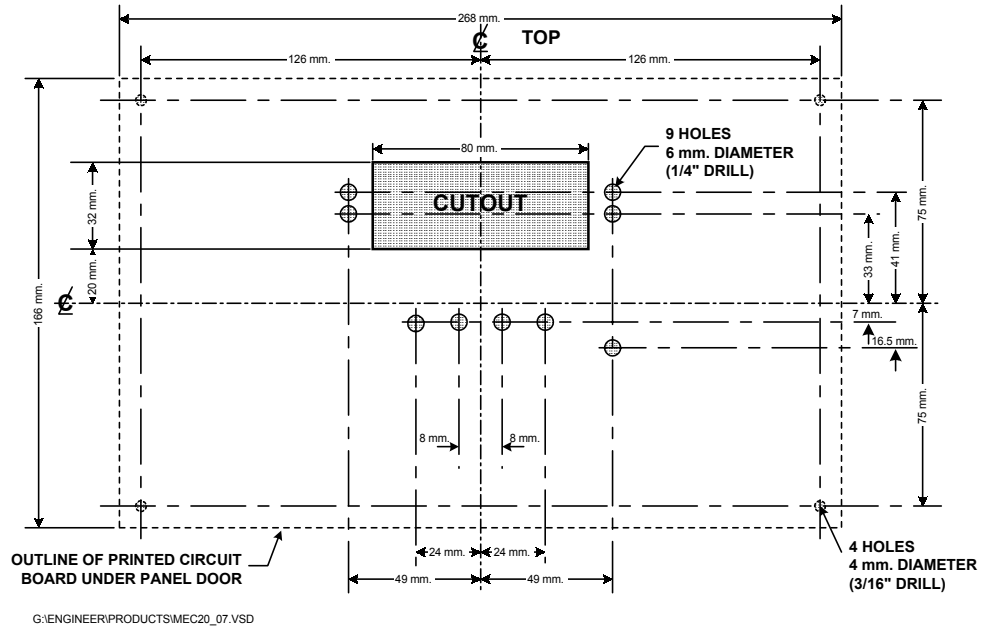

FIGURE #6

2.14. MEC 20 ASSEMBLY - SIDE VIEW

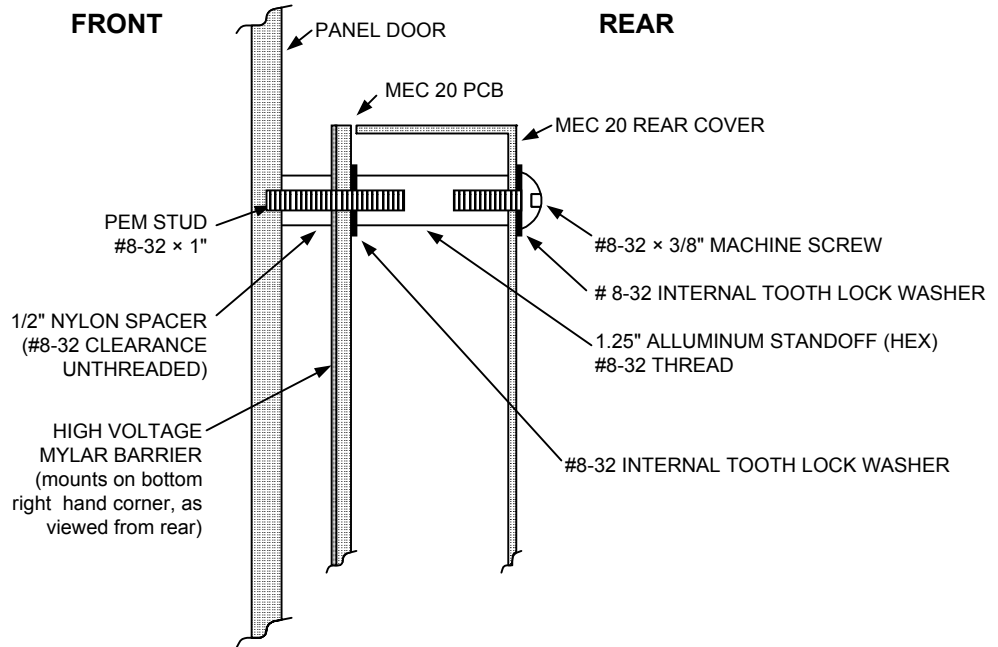

FIGURE #7

3. DESCRIPTION

The MEC 20 controller consists of three parts; a Lexan faceplate, which is mounted externally on the enclosure door, a printed circuit board (PCB) which is mounted inside the enclosure door, and a rear cover for the PCB.

3.1. LEXAN FACEPLATE

The Lexan faceplate is shown as in FIGURE #10. The Lexan push-buttons are connected to the main PCB via plug-in ribbon cable. The main features of the Lexan faceplate are described as follows with reference to FIGURE #10.

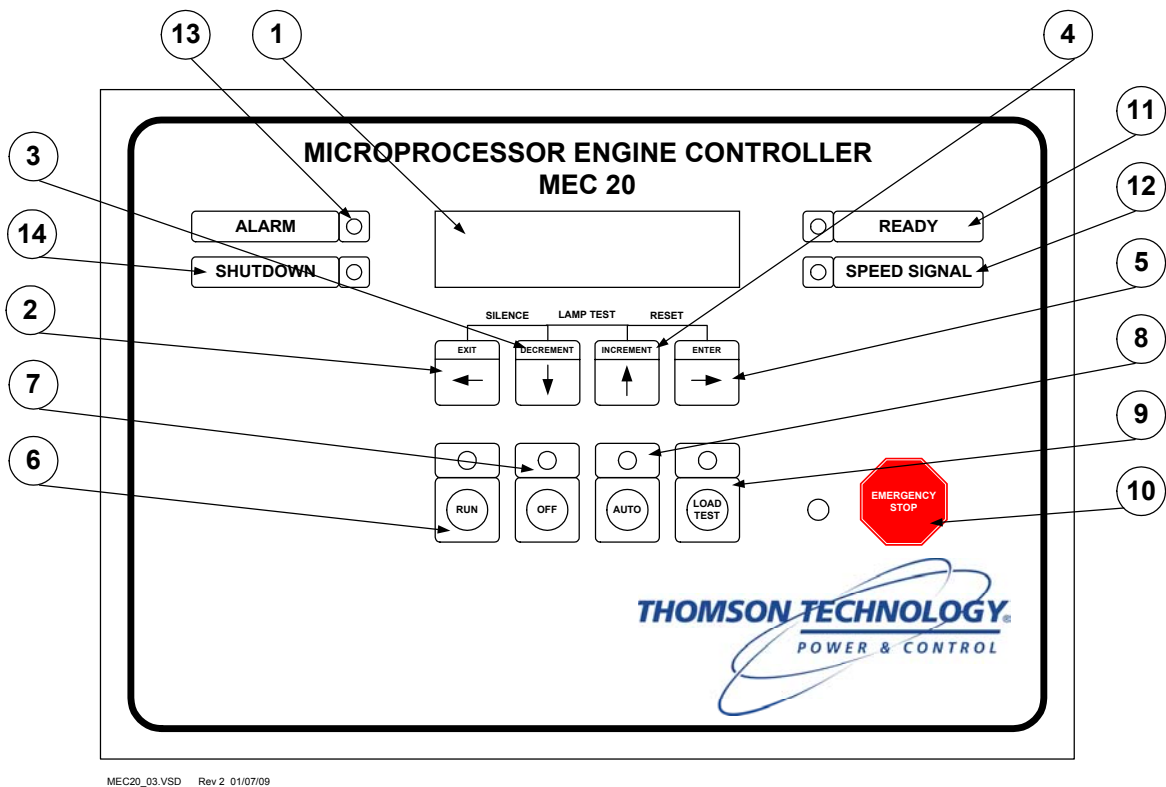

MEC20_03.VSD Rev 2 01/07/09

FIGURE #10

- ① LCD viewing window. The LCD display is mounted on the main PCB that is visible through the lexan faceplate viewing window.
- ② EXIT push-button. The EXIT function is used to scroll backwards through the status menus or programming prompts to the previous item. The EXIT function is used to “exit” the programming menu by holding this button down for approximately 2 seconds while in the programming mode.
- ③ DECREMENT push-button. The DECREMENT function is used to change a programming value while in the programming mode. When this push-

button is held down, the displayed value will be “decremented” to a lower value as desired. **Note:** The longer the push-button is held down, the faster the value will be decremented.

- ④ INCREMENT push-button. The INCREMENT function is used to change a programming value while in the programming mode or to select a desired programming menu loop. When this push-button is held down, the displayed value will be “incremented” to a higher value as desired. **Note:** The longer the push-button is held down, the faster the value will be incremented.
- ⑤ ENTER push-button. The ENTER function is used to scroll forwards through the status menus or programming prompts to the next item. The ENTER function is used to “enter” a programming mode as well as accepting changed programming values. **Note:** In the programming mode, the longer the ENTER push-button is held down, the faster the next menu prompts will appear.
- ⑥ RUN push-button and LED light viewing window. The RUN function is used to initiate a manual start signal to the engine-generator set. Refer to the operating instructions for detailed information.
- ⑦ OFF push-button and LED light viewing window. The OFF function is used to initiate a stop signal to the engine-generator set. Refer to the operating instructions for detailed information.
- ⑧ AUTO push-button and LED light viewing window. The AUTO function is used to initiate automatic operation of the engine-generator set. Refer to the operating instructions for detailed information.
- ⑨ LOAD TEST push-button and LED light viewing window. The LOAD TEST function is used to initiate load test of the engine-generator set when connected to an associated transfer switch. Refer to the operating instructions for detailed information.
- ⑩ EMERGENCY STOP push-button and LED light viewing window. The EMERGENCY STOP function is used to initiate an emergency stop signal to the engine-generator set. Refer to the operating instructions for detailed information.
- ⑪ READY LED light viewing window. The READY LED illuminates when the engine-generator set is set for automatic operation and no shutdown or alarm faults have been activated.
- ⑫ SPEED SIGNAL LED light viewing window. The SPEED SIGNAL LED

illuminates when the engines speed signal is detected (i.e. the engine is turning over).

- ⑬ ALARM LED light viewing window. The ALARM LED illuminates (flashes) when any pre-programmed alarm fault has been activated.
- ⑭ SHUTDOWN LED light viewing window. The SHUTDOWN LED illuminates (flashes) when any pre-programmed shutdown fault has been activated.

3.2. PRINTED CIRCUIT BOARD

The printed circuit board (PCB) is shown in FIGURE #11. The PCB contains the following user interface items:

MEC 20 CIRCUIT BOARD LAYOUT

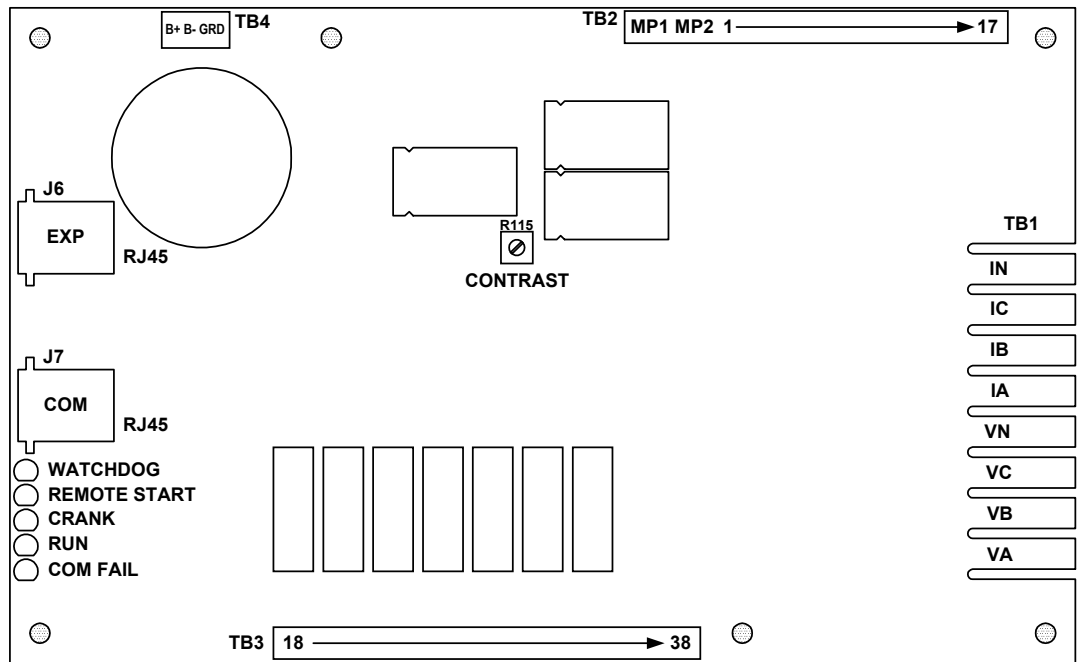

G:\ENGINEER\PRODUCTS\MEC20_02.VSD Rev. 2 01/07/09
DRAWING SCALE (mm) = .6:1

FIGURE #11

3.2.1. TERMINAL BLOCKS

Four terminal blocks are located on the PCB as follows:

TB1 AC Voltage and Current sensing terminal block (120-600VAC & 0-5AAC)

WARNING!!!

Voltage sensing circuits are capable of lethal voltages while energized. Current transformer (CT) secondary circuits are capable of generating lethal voltages when open circuited with their primary circuit energized. Standard safety procedures should be followed and be performed by qualified personnel only. Failure to do so may cause personal injury and/or death.

TB2 Speed sensing and digital contact input terminal block

TB3 Output contacts and engine temperature/pressure input signal terminal block

TB4 DC power input and ground connection terminal block

3.2.2. DIAGNOSTIC LED'S

The MEC 20 controller provides five diagnostics LED lights that are mounted on the rear of the printed circuit board as per FIGURE #11. Their functions are described as follows:

3.2.2.1. **WATCHDOG**

This LED flashes on and off at irregular intervals which indicates that the microprocessor is functioning normally.

3.2.2.2. **REMOTE START**

This LED is illuminated whenever the MEC 20 has received a remote start signal.

3.2.2.3. **CRANK**

This LED is illuminated whenever the MEC 20 is initiating an engine cranking signal.

3.2.2.4. **RUN**

This LED is illuminated whenever the MEC 20 has called the engine to run.

3.2.2.5. **COMMON FAIL**

This LED is illuminated whenever the MEC 20 has initiated a common fail signal (i.e. whenever an alarm or shutdown fault has been activated).

Note: All LED's will be illuminated whenever a lamp test function is performed.

3.2.3. CONTRAST ADJUSTMENT (R115)

A contrast adjustment potentiometer is located on the rear of the PCB and is factory set for ambient temperatures of 15° to 30° Celsius. For different ambient temperatures, consult the factory for adjustment procedures.

3.2.4. COMMUNICATION PORTS

Two RJ45 communication ports are provided on the circuit board for optional features as follows:

3.2.4.1 J6 - EXP This port is utilized to interconnect an external expansion module for additional output contacts and/or the EAP 110 remote annunciator. Refer to *Section 7.0 & 8.0* for additional information.

3.2.4.2 J7 - COM This port is utilized to interconnect to a remote communication system for remote monitoring and control. Refer to *Section 6.0* for additional information.

4. FAULT CIRCUIT DESCRIPTIONS

The MEC 20 engine-generator controller utilizes many analog and digital inputs to perform both monitoring and control functions. Three types of fault circuits are used to monitor and control the engine-generator set. The first type is *Internal Fault Circuits* that are derived from a combination of digital and analog inputs. The second type is *Digital Input Fault circuits* that are initiated from external contact inputs. The third type is *Analog Input Fault circuits* that are initiated from external analog signal inputs. The following functional block diagram (FIGURE #12) shows how all input/output fault circuits are organized.

4.1. MEC 20 FUNCTIONAL BLOCK DIAGRAM

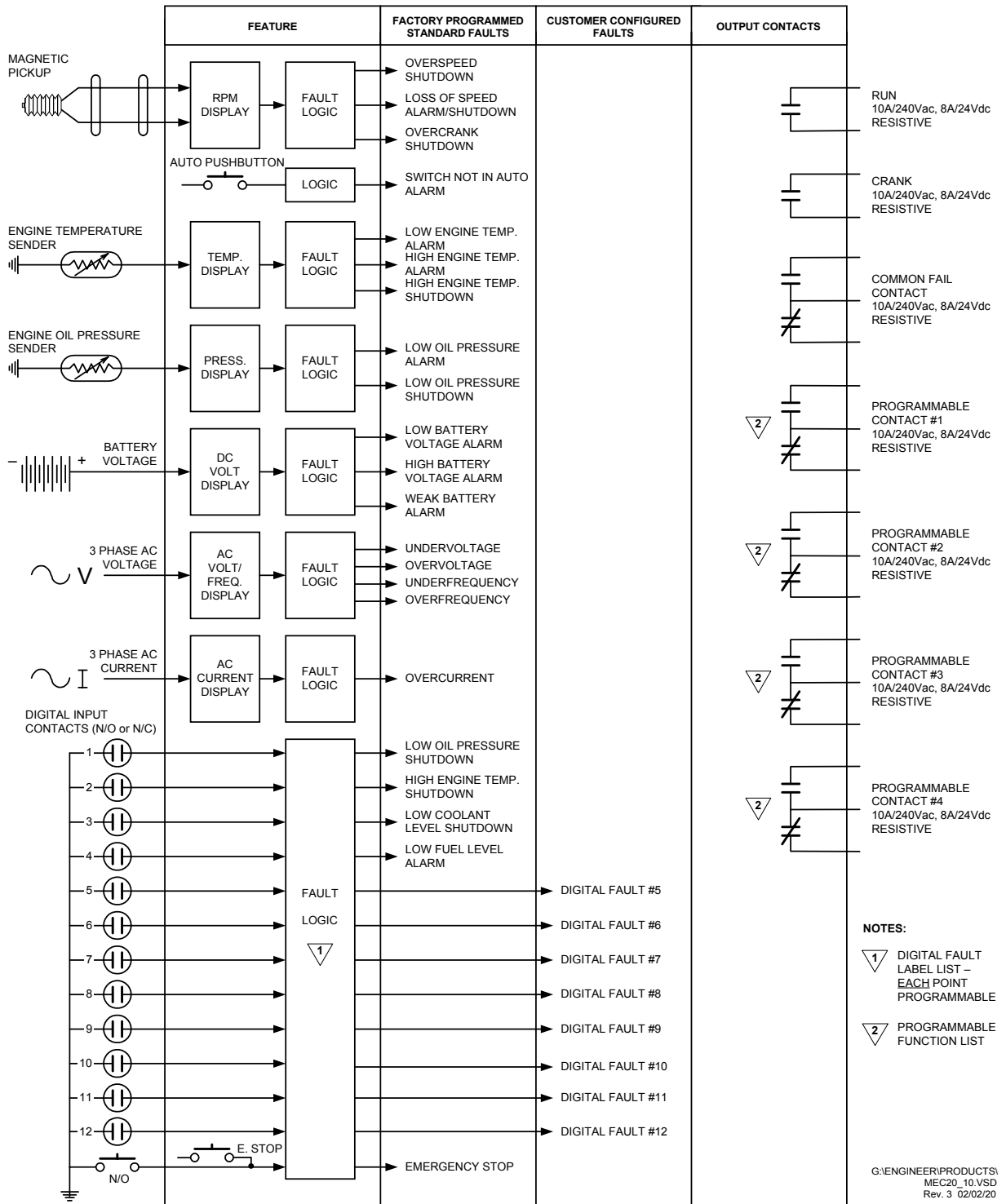

FIGURE #12

4.2. INTERNAL FAULT CIRCUITS

The MEC 20 Engine Controller provides four internally activated fault circuits as described below. All internal fault circuits are provided as standard with every MEC 20 controller.

4.2.1. OVERCRANK

The overcrank fault circuit is initiated when the engine fails to start after the selected crank time or number of crank cycles. The overcrank fault circuit is internally programmed as a latching shutdown fault and is not user programmable. Refer to the programming instructions for further information.

4.2.2. OVERSPEED

The overspeed fault circuit is initiated when the engine's speed has increased above the overspeed setpoint. The overspeed fault circuit is internally programmed as a latching shutdown fault. The overspeed shutdown fault circuit is programmable for the percentage of nominal engine speed (i.e. overspeed setpoint) and for the transient time delay period. The programming prompts for overspeed are located in the main menu programming loop. Refer to the programming instructions for further information.

4.2.3. LOSS OF SPEED

The loss of speed fault circuit is initiated when the engine's speed sensing circuit does not detect a speed signal for a period more than 2 seconds following a run signal. The loss of speed fault circuit may be user programmed as a latching shutdown fault or alarm only. The programming prompts for loss of speed are located in the main menu programming loop. Refer to the programming instructions for further information.

4.2.4. SWITCH NOT IN AUTO

The "Switch Not In Auto" fault circuit is initiated when the controller's operating mode switch is changed from the auto position to any other position via the front mounted keypad. This fault is internally programmed

as a non-latching alarm. In the main programming loop, this alarm may be user programmed to initiate the common fail output relay.

4.3. DIGITAL FAULT INPUT CIRCUITS

The MEC 20 Engine Controller provides up twelve digital fault input circuits that are user programmable. Each digital fault input circuit is activated via a remote sensing contact that is external to the controller.

Each digital fault input circuit may be programmed with a unique fault label description as stored in the controller’s non-volatile memory. The following digital fault labels are provided in each MEC 20 engine controller:

- | | |
|--|--------------------|
| AIR DAMPER TRIPPED | HIGH OIL TEMP |
| BAT CHARGER INPUT FAIL | HIGH WINDING TEMP |
| BAT CHRГ TROUBLE | IDLE |
| BREAKER TRIPPED | LOW COOLANT LEVEL |
| DC FAIL | LOW ENGINE TEMP |
| FAILED TO SYNC | LOW FUEL PRESS |
| GEN BREAKER OPEN | LOW FUEL LEVEL |
| GROUND FAULT | LOW OIL LEVEL |
| HIGH BEARING TEMP | LOW OIL PRESSURE |
| HIGH COOLER VIBRATION | REMOTE EMERG. STOP |
| HIGH ENGINE TEMP | REVERSE POWER |
| HIGH ENGINE VIBRATION | BASIN RUPTURE |
| HIGH FUEL LEVEL | ATS IN BYPASS |
| HIGH OIL LEVEL | FUEL LEAK |
| NO LOAD TEST | LOW FUEL PRESS |
| *HIGHINTKMANFTEMP | BAT CHARGER FAIL |
| VENT DAMPER FAIL | |
| HIGH FUEL LEVEL | |
| FAIL TO SYNC | |
| “Blank” (i.e. no text for unused inputs) | |

Note: Up to six *custom “user defined”* fault label names may be specified for the MEC 20 controller at time of purchase. The six *custom* fault label names cannot be changed once shipped from the factory.

4.3.1. FACTORY PROGRAMMED DIGITAL FAULT CIRCUITS

The MEC 20 is supplied from the factory programmed with twelve standard digital fault circuits as follows:

FAULT NAME	FAULT ACTION	INPUT TERMINAL #
Low Oil Pressure	Shutdown	1
High Engine Temperature	Shutdown	2
Battery Charger Input Fail ^o	Alarm	3
Low Fuel Level	Alarm	4
Digital Input #5	Alarm	5
Digital Input #6	Alarm	6
Digital Input #7	Alarm	7
Digital Input #8	Alarm	8
Digital Input #9	Alarm	9
Digital Input #10	Alarm	10
Remote Emergency Stop	Shutdown	11
Idle	N/A	12

Refer to *Section 11.4 Digital Fault Programming Menu* for the factory default settings.

Note: Fault Input #5 - #10 must be customer configured unless specified at time of order.

All faults require a customer connected contact to the MEC 20 input terminal as indicated. All fault circuits may be user field programmed for different control functions or alternate fault names.

^o**Note:** For CSA C282 applications the controller will be factory supplied with Low coolant level shutdown in place of Battery charger input fail alarm. Refer to the programming instructions for further information on digital fault circuits.

Note: Shutdown functions for Low Oil Pressure and High Engine Temperature may alternatively be provided via analog pressure and

temperature sender inputs if programmed accordingly in the analog fault programming menu. Refer to *Section 11.3* for further information.

4.4. ANALOG FAULT INPUT CIRCUITS

The MEC 20 Engine Controller provides up to fifteen analog fault input circuits that are user programmable. The controller is supplied from the factory with fifteen standard analog fault circuits. Each analog fault input circuit is activated via specific analog signal type. Refer to *Section 11.3 Analog Fault Programming Menu* for the factory default program settings for each analog fault provided.

WARNING!!!

The analog protection circuits for voltage, frequency, current, engine oil pressure, engine temperature and engine speed will be set at factory default settings only. Final settings will be required to be set by the commissioning authority. Failure to do so may result in severe equipment failure or damage.

4.4.1. ANALOG FAULT CIRCUITS

The MEC 20 is supplied from the factory with fifteen standard analog fault circuits as follows:

FAULT NAME	FAULT ACTION	INPUT SIGNAL
Undervoltage	Shutdown	Generator voltage
Overvoltage	Shutdown	Generator voltage
Underfrequency	Alarm	Generator frequency
Overfrequency	Alarm	Generator frequency
Overcurrent	Alarm	Generator current
Weak battery	Alarm	Battery voltage
Low battery voltage	Alarm	Battery voltage
High battery voltage	Alarm	Battery voltage
Low engine temperature	Alarm	Engine temperature
High engine temperature #1	Alarm	Engine temperature
High engine temperature #2	Shutdown	Engine temperature
Low oil pressure #1	Alarm	Oil pressure
Low oil pressure #2	Shutdown	Oil pressure
Overspeed	Shutdown	Engine speed
Loss of speed signal	Shutdown	Engine speed

All fault circuits may be user field programmed for different control functions however their designated fault function is not programmable. Refer to the programming instructions for further information.

4.4.2. GENERATOR AC VOLTAGE/FREQUENCY/CURRENT

4.4.2.1. GENERATOR UNDERVOLTAGE

The MEC 20 controller provides a 3-phase undervoltage sensor for the generator supply. The undervoltage sensor is programmable for type of fault action (i.e. alarm or shutdown), pickup and dropout voltage setpoints (i.e. adjustable hysteresis) and transient time delay settings. Refer to the programming instructions for further information.

4.4.2.2. GENERATOR OVERVOLTAGE

The MEC 20 controller provides a 3-phase overvoltage sensor for the generator supply. The overvoltage sensor is programmable for type of fault action (i.e. alarm or shutdown), pickup and dropout voltage setpoints (i.e. adjustable hysteresis) and transient time delay settings. Refer to the programming instructions for further information.

4.4.2.3. GENERATOR UNDERFREQUENCY

The MEC 20 controller provides a underfrequency sensor for the generator supply. The underfrequency sensor is programmable for type of fault action (i.e. alarm or shutdown), frequency setpoint, and transient time delay settings. Refer to the programming instructions for further information.

4.4.2.4. GENERATOR OVERFREQUENCY

The MEC 20 controller provides an overfrequency sensor for the generator supply. The overfrequency sensor is programmable for type of fault action (i.e. alarm or shutdown), frequency setpoint, and transient time delay settings. Refer to the programming instructions for further information.

4.4.2.5. GENERATOR OVERCURRENT

The MEC 20 controller provides a 3-phase current sensor for the generator supply. The current sensor is programmable for type of fault action (i.e. alarm or shutdown), pickup current setpoint, and transient time delay settings. Refer to the programming instructions for further information.

4.4.3. BATTERY VOLTAGE ANALOG INPUT

The MEC 20's battery voltage sensor measures DC voltage on terminals B+ and B- that are connected to the engines cranking battery. The battery voltage sensor provides information to perform the following control functions:

4.4.3.1. WEAK BATTERY ALARM

The weak battery alarm fault circuit is activated when the battery voltage drops below a pre-determined setpoint for a specified time delay. The weak battery alarm will detect a low capacity (i.e. "weak") battery condition during the cranking cycle. The weak battery alarm is programmed for a lower battery voltage setpoint and shorter time delay than the low battery alarm function. The weak battery alarm fault is programmable for voltage setpoint level, transient time delay settings and other functions. Refer to the programming instructions for further information.

4.4.3.2. LOW BATTERY VOLTAGE ALARM

The low battery voltage alarm fault circuit is activated when the battery voltage drops below a pre-determined setpoint for a specified time delay. The low battery voltage alarm fault is programmable for the voltage setpoint level, transient time delay settings and other functions. Refer to the programming instructions for further information.

4.4.3.3. HIGH BATTERY VOLTAGE ALARM

The high battery voltage alarm fault circuit is activated when the battery voltage rises above a pre-determined setpoint for a specified time delay. The high battery voltage alarm fault is

programmable for voltage setpoint level, transient time delay settings and other functions. Refer to the programming instructions for further information.

4.4.4. ENGINE TEMPERATURE ANALOG INPUT

The MEC 20's engine temperature sensor measures a DC analog signal from an engine mounted sender. The MEC 20 software provides calibration for engine temperature to coordinate with the engine mounted sender and control logic to detect a wiring or sender failure (i.e. open or shorted signal). In case of a sender or wiring failure, the MEC 20 will display zero or 9999 °C and will initiate an alarm signal as programmed by the user. The engine temperature analog input provides the following control functions:

4.4.4.1. LOW ENGINE TEMPERATURE ALARM

The low engine temperature alarm fault circuit is activated when the engine temperature drops below a pre-determined setpoint for a specified time delay. The low engine temperature alarm fault is programmable for temperature setpoint level, transient time delay settings and other functions. Refer to the programming instructions for further information.

4.4.4.2. HIGH ENGINE TEMPERATURE #1 ALARM

The high engine temperature alarm fault circuit is activated when the engine temperature rises above a pre-determined setpoint for a specified time delay. The high engine temperature alarm fault is programmable for the level of temperature setpoint, transient time delay settings and other functions. Refer to the programming instructions for further information.

4.4.4.3. HIGH ENGINE TEMPERATURE #2 SHUTDOWN

The high engine temperature shutdown fault circuit is activated when the engine temperature rises above a pre-determined setpoint for a specified time delay. The high engine temperature shutdown fault is programmable for the level of temperature setpoint, transient time delay settings and other functions. Refer to the programming instructions for further information.

Note: High Engine Temperature shutdown may alternately be programmed and wired as a digital fault input contact. Refer to *Section 4.3* for further details.

4.4.5. ENGINE OIL PRESSURE ANALOG INPUT

The MEC 20's engine oil pressure sensor measures a DC analog signal from an engine mounted sender. The MEC 20 software provides calibration for oil pressure to coordinate with the engine mounted sender and control logic to detect a wiring or sender failure (i.e. open or shorted signal). In case of a sender or wiring failure, the MEC 20 will display zero or 9999 PSI and will initiate an alarm and/or shutdown signal as programmed by the user. The engine oil pressure analog input provides the following control function:

4.4.5.1. LOW OIL PRESSURE #1 ALARM

The low oil pressure alarm fault circuit is activated when the oil pressure drops below a pre-determined setpoint for a specified time delay. The low oil pressure alarm fault is programmable for pressure setpoint level, transient time delay settings and other functions. Refer to the programming instructions for further information.

4.4.5.2. LOW OIL PRESSURE #2 SHUTDOWN

The low oil pressure shutdown fault circuit is activated when the oil pressure drops below a pre-determined setpoint for a specified time delay. The low oil pressure shutdown fault is programmable for pressure setpoint level, transient time delay settings and other functions. Refer to the programming instructions for further information.

Note: Low Oil Pressure shutdown may alternately be programmed and wired as a digital fault input contact. Refer to *Section 4.3* for further details.

4.4.6. ENGINE SPEED ANALOG INPUT

The MEC 20's engine speed sensor measures AC voltage and frequency from an engine mounted magnetic pick-up. The engine speed sensor provides information to perform the following control functions:

Overspeed shutdown
Crank Disconnect control
Loss of speed signal detection
Starter Re-engage control
RPM display

Refer to the programming instructions for further information.

5. CONTROL OUTPUT CONTACT DESCRIPTIONS

All output contacts from the MEC 20 Engine Controller are non-powered (i.e. dry contacts) and are rated 10A/240Vac, 8A/24Vdc resistive (3A inductive, 0.4pf). Output contacts are not fused therefore external overcurrent protection (maximum 10A) is required for all control circuits using these contacts. Contacts indicated on schematic drawings and connection diagrams are shown in a de-energized state and will change state upon activation of the specific control function.

5.1. RUN, CRANK, COMMON FAIL OUTPUT CONTACTS

The MEC 20 Controller provides three dedicated output contacts for basic control and alarm circuits as described below:

5.1.1. RUN OUTPUT

The Run output contact is a Form “A” dry contact and is used to control the engines “run” circuit. This typically includes external control devices such as “fuel rack solenoids” or electronic governors’. **Note:** An additional pilot relay will be required to energize high current devices that exceed the 10A resistive rating. The run output control logic provides an “energize to run signal” (i.e. the run contact closes when a run condition is activated). **Note:** For energize to *stop* control logic, refer to the programmable output control function.

5.1.2. CRANK OUTPUT

The Crank output contact is a Form “A” dry contact and is used to control an external crank pilot relay that directly controls the engine starter motor. **Note:** An external crank pilot relay is required to energize the high current starter motor pinion solenoid that exceeds the 10A resistive crank output contact rating. The crank output contact closes when a crank condition is activated and the contact will automatically open when crank disconnect speed is obtained and/or the generators output AC voltage exceeds 10%

of nominal level. The generators output AC voltage is utilized for back-up crank disconnect protection should the speed sensor fail.

5.1.3. COMMON FAIL OUTPUT

The Common Fail output contact is a Form “C” dry contact and is typically used to provide a remote alarm signal should the generator set fail. The common fail output contact closes when any programmed alarm or shutdown fault condition is activated. **Note:** The MEC 20 may be programmed to activate the common fail output for any desired fault input circuits or for abnormal switch position (i.e. switch not in auto). Refer to the programming instructions for further information.

5.2. PROGRAMMABLE OUTPUT CONTACTS

The MEC 20 Controller provides four standard programmable output contacts. Each programmable output is a Form “C” dry contact that is programmable for many different control functions. All programmable outputs may be user field programmed for the desired control function. The following programmable features are provided:

ENERGIZE TO STOP	GEN READY TO LOAD
AIR FLAP	UTILITY READY TO LOAD
OIL BYPASS TIMER COMPLETE	DIGITAL FAULTS #1 – #12
COMMON FAIL	OVERSPEED
SWITCH NOT IN AUTO	LOSS OF SPEED SIGNAL
ENGINE READY	LOW BAT VOLTAGE
ENGINE RUN (FUEL)	HIGH BAT VOLTAGE
PREHEAT	WEAK BAT VOLTAGE
ENGINE RUNNING	LOW OIL PRESS #1 ALARM
ATS TEST	LOW OIL PRESS #2 SHUTDOWN
COMMON ALARM	HIGH ENG TEMP #1 ALARM
COMMON SHUTDOWN	HIGH ENG TEMP #2 SHUTDOWN
EPS SUPPLYING LOAD	

5.2.1. ENERGIZE TO STOP

The designated programmable output relay will energize when a stop signal has been activated. The output will remain energized for 10

seconds once the engine has come to a complete stop, then de-energizes.

5.2.2. IDLE CONTROL

The designated programmable output relay will energize when an idle signal has been issued to the engine controller. The output contact would typically be connected to the "idle/run" input control of an electronic governor. **Note:** The controller receives an idle signal from a digital input contact that must additionally be programmed for an idle function. During an idle condition, the engine controller automatically bypasses all alarm or shutdown circuits (except oil pressure and overspeed) which are programmed for "bypass on start".

5.2.3. PRE/POST/CYCLIC LUBE CONTROL

The designated programmable output relay will energize when a "lube" signal has been initiated. **Note:** The Lube function will be automatically terminated once an engine start signal is issued. Refer to the programming instructions for further information.

5.2.4. SWITCH NOT IN AUTO

The designated programmable output relay will energize when the controller's operation mode switch is not in the auto position.

5.2.5. OVERCURRENT

The designated programmable output relay will energize when the overcurrent fault circuit is activated. The output will remain energized until the fault condition has been manually reset (if programmed as a latching type fault) or until the overcurrent level drops below the setpoint.

5.2.6. ENGINE READY

The designated programmable output relay will energize when the engine controller's mode switch is in the auto mode and no shutdown or alarm conditions are present.

5.2.7. PREHEAT

The designated programmable output relay will energize during the start delay timer period and cranking period until the engine starts and reaches

crank disconnect speed. The preheat output is typically used for an engine starting aid such as glow plugs. **Note:** An external pilot relay is required to switch the high current glow plug load.

5.2.8. GEN READY TO LOAD

The designated programmable output relay will energize when the generators voltage and frequency exceeds predetermined setpoints (e.g. voltage 90% nominal, frequency 95% nominal as user programmed) and a warm-up time delay period expires. Once the output has energized, it will remain latched on irrespective of voltage/frequency levels until the controller either has a stop/shutdown signal, or the engine's speed drops below crank disconnect level. The voltage, frequency and time delay levels programmable. Refer to *Section 10.3* for Programming.

The Generator Ready To Load output is typically used in an Auto Mains Failure (AMF) application. Refer to *Section 9.3.5* for further details on sequence of operation.

5.2.9. UTILITY READY TO LOAD

The designated programmable output relay will energize when the remote start input has not been activated (i.e. contact on terminals 16 & 17 is not closed) and the Return Delay & Neutral Delays have expired (if programmed). The output will de-energize when the remote start input has been activated and the Engine Start Delay & warm-up Delays have expired (if programmed). This output is typically used for Auto Mains Failure (AMF) applications. Refer to *Section 9.3.5* for further details on the sequence of operation.

5.2.10. ENGINE RUNNING

The designated programmable output relay will energize when the engine has started and has reached crank disconnect speed.

5.2.11. ENGINE RUN (FUEL)

The designated programmable output relay will energize when the engine "RUN" (i.e. FUEL) energizes prior to the engine starting. The output will remain on until the engine has reached a "stop" or "shutdown" command.

5.2.12. AIRFLAP

The designated programmable output relay will energize when the engine's speed exceeds the overspeed setpoint level. The output will remain energized until the engine's speed drops below the low speed setpoint (typically 5% of rated speed). **Note:** An external pilot relay will be required if the main air flap solenoid current rating exceeds the MEC 20 contact rating.

5.2.13. ATS TEST

NOTE:

This control feature is only operative if a remote transfer switch is interconnected with remote testing capability.

The designated programmable output relay will energize when a load test operating mode is selected via the front keypad push-button. Once initiated, the engine will receive a start signal from the transfer switch and upon the generator reaching nominal voltage and frequency levels, a load transfer will be initiated. The generator set will remain running on load until a different operating mode is selected or the generator set develops an alarm or shutdown condition.

Notes:

- 1) The MEC 20's standard programmable output contact is factory supplied with the ATS LOADTEST function programmed. When the "Utility Ready to Load" and "Generator Ready to Load" outputs are programmed, the "Load Test" programmable output is not required as the engine starting logic is internally initiated.
- 2) When both "Utility Ready to Load" and "Generator Ready to Load" programmable outputs are programmed and utilized in a AMF control configuration, the ATS Output is not utilized (i.e. engine start signal is internally generated).

5.2.14. OIL BYPASS TIMER COMPLETE

The designated programmable output relay will energize upon the expiry of the controller's oil bypass delay timer function, following a normal start sequence.

5.2.15. COMMON ALARM

The designated programmable output relay will energize when any alarm fault circuit has been activated.

5.2.16. COMMON FAIL

The designated programmable output relay will energize when any alarm or shutdown fault circuit has been activated.

5.2.17. COMMON SHUTDOWN

The designated programmable output relay will energize when any shutdown fault circuit has been activated.

5.2.18. EPS SUPPLYING LOAD

The designated programmable output relay will energize when the engine is running and the generator is supplying current to the load more than or equal to 10% of nominal CT ratio.

6. REMOTE COMMUNICATION OPTION

The MEC 20 engine generator controller is available with an optional remote communication feature. The remote communication feature allows a MEC 20 controller to be monitored and controlled from a remote location via serial communication link to a personal computer (PC). PC's may be connected locally via serial communication cable to the MEC 20 or remotely via modem and telephone systems. Remote communication can be via customer supplied equipment or an external communication interface module (CIM) as manufactured by Thomson Technology. The CIM module utilizes an internal modem and contains Modbus™ protocol to interface with different remote monitoring software programs. Refer to separate literature for detailed information on the CIM module. The MEC 20 remote communication option must be ordered and be factory enabled prior to shipment. The communication feature cannot be user enabled once shipped from the factory.

The MEC 20 communication port utilizes a RS422 data transmission signal which is directly interconnected to the CIM module via 8 conductor, shielded cable with plug-in RJ45 connectors. Refer to FIGURE #14 & 15 for detailed information on direct connected or remote connected PC applications with CIM module.

™Trademarks belong to their respective parties.

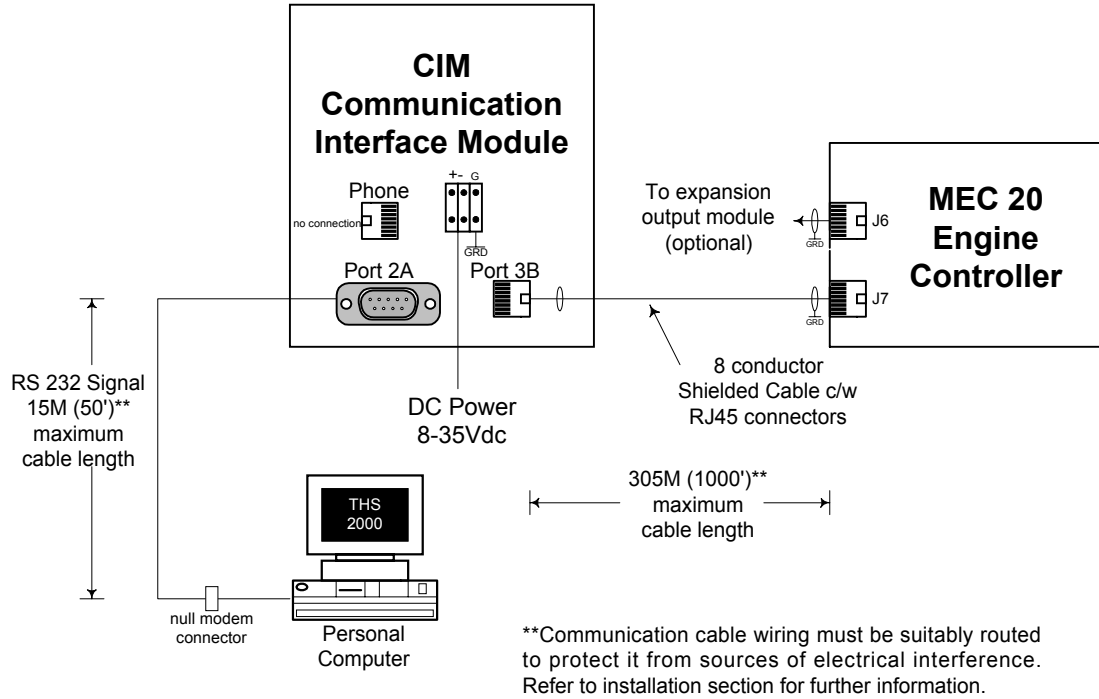

G:\ENGINEER\PRODUCTS\MEC20\MEC20_20.VSD

FIGURE #14 MEC 20 WITH CIM MODULE & DIRECT CONNECTED PC

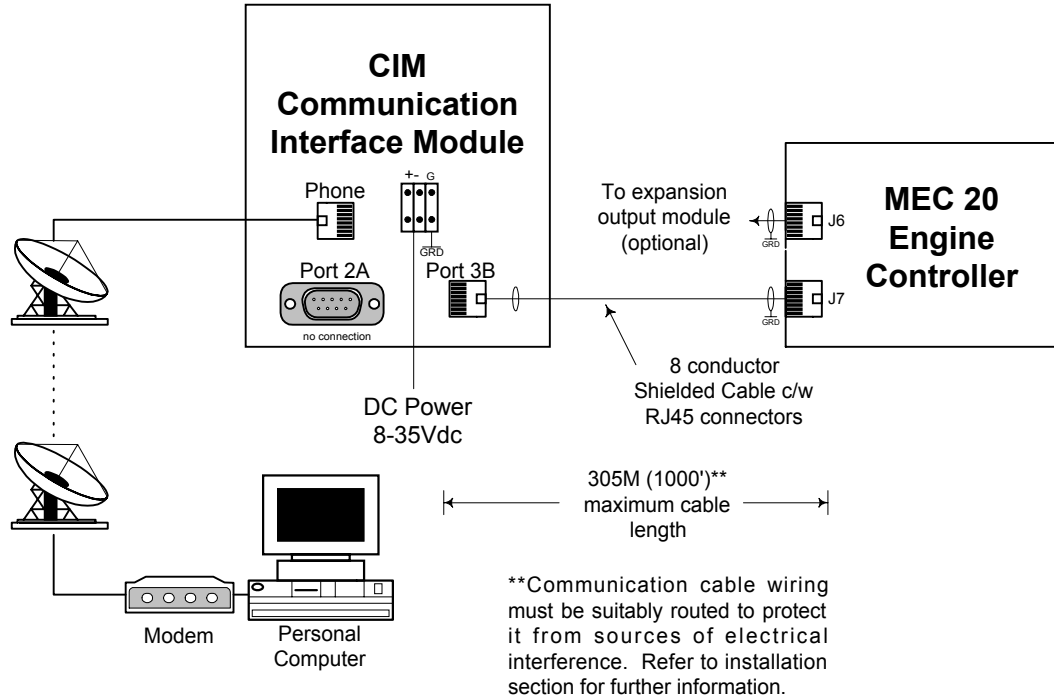

G:\ENGINEER\PRODUCTS\MEC20\MEC20_21.VSD

FIGURE #15 MEC 20 WITH CIM MODULE & REMOTE CONNECTED PC

The MEC 20 RS422 communication port allows multiple MEC 20 controllers to be directly interconnected together to form a single network system. Up to 10 MEC 20 controllers may be interconnected to a single CIM module. Each MEC 20 controller is programmed with an unique communication address number for the remote communication system to reference. The network system may be connected to a local PC or to a remote PC via telephone system and CIM module. Refer to FIGURE #15 for a typical MEC 20 network system with CIM module.

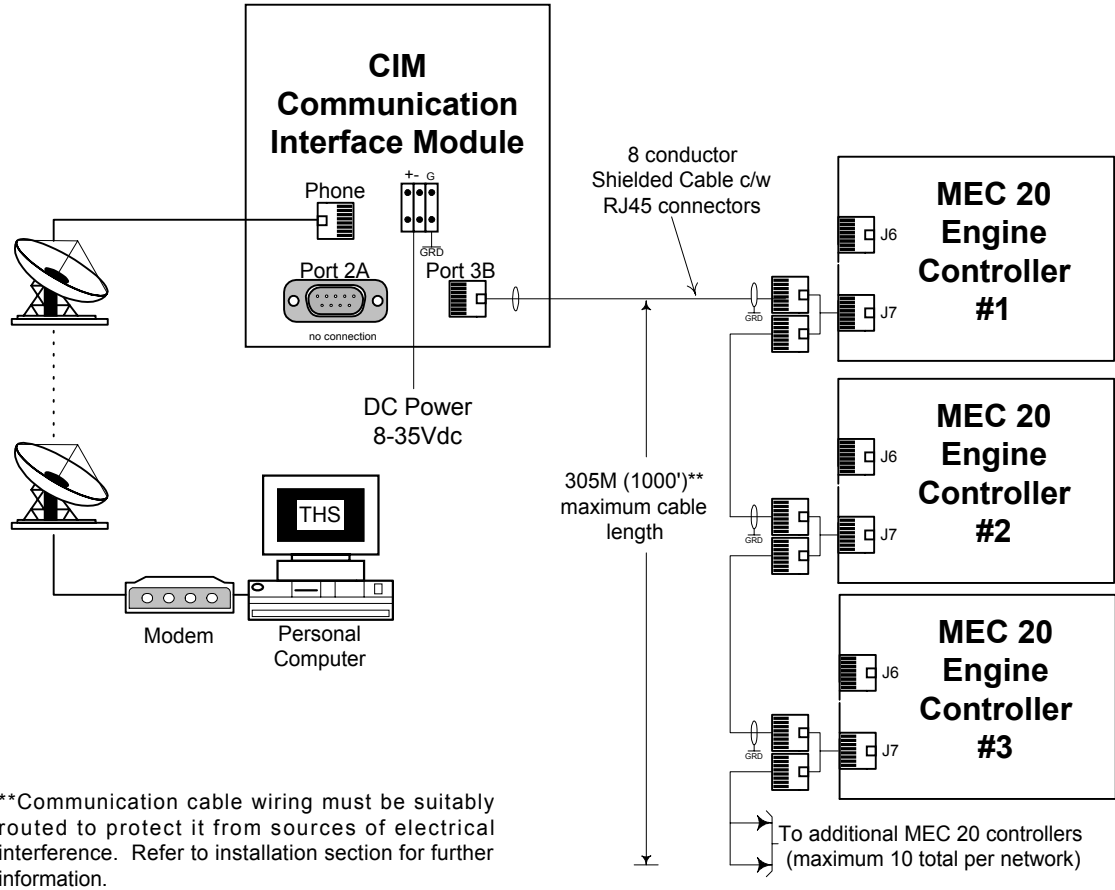

G:\ENGINEER\PRODUCTS\MEC20\MEC20_22.VSD

FIGURE #16 NETWORKED MEC 20 INTERCONNECTION DIAGRAM

7. EXPANSION OUTPUT MODULE OPTION

An optional expansion output module is available for the MEC 20 engine generator controller. This module provides 16 individual fault output contacts for remote alarming or control purposes. The expansion module is interconnected to the MEC 20 controller via RS 422 communication link utilizing 8 conductor shielded cable with plug-in RJ45 connectors. Refer to FIGURE #17 for the expansion output module connection diagram.

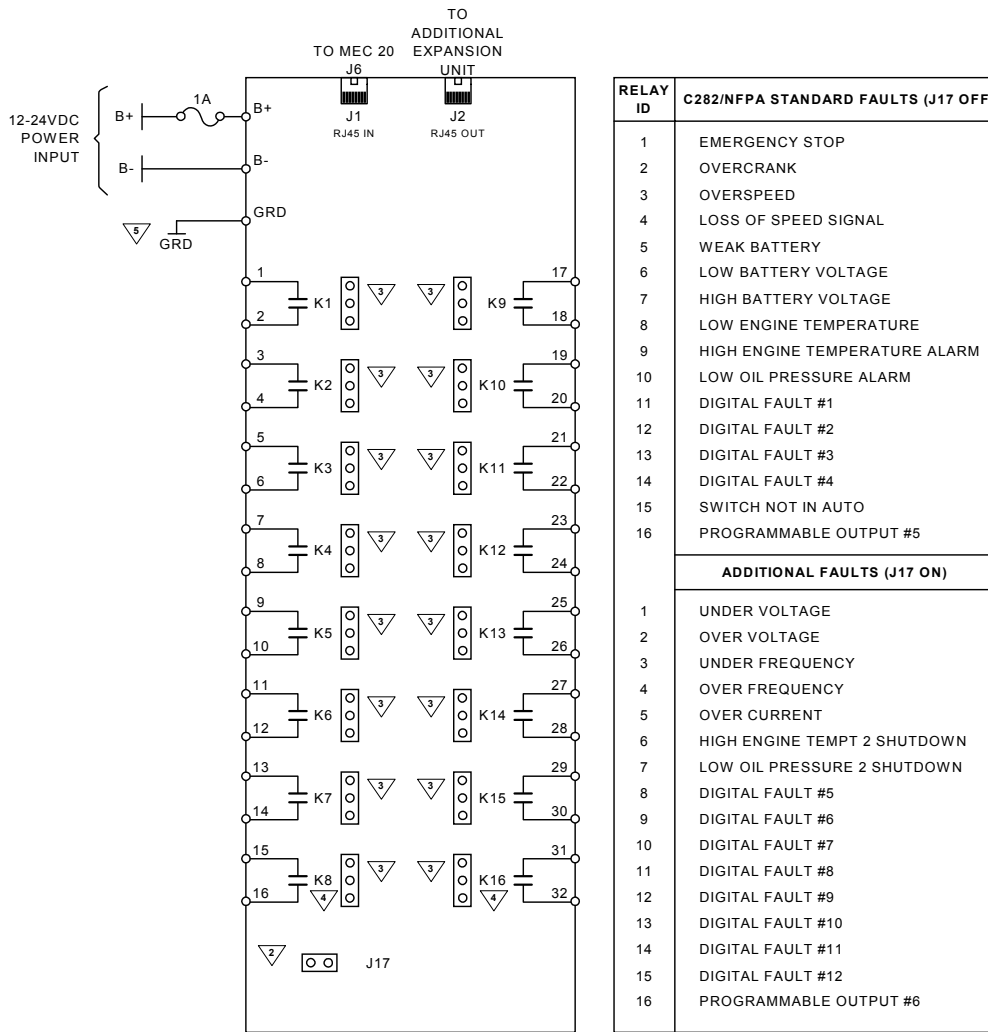

- NOTES:**
- 1 ALL CONTACTS RATED MAXIMUM 0.5A, 120Vac/1.0A, 30Vdc RESISTIVE
 - 2 PROGRAMMABLE MODULE ADDRESS (REMOVE JUMPER FOR STANDARD C282/NFPA FAULTS, ADD JUMPER FOR ADDITIONAL FAULTS)
 - 3 CONTACT LOGIC IS INDIVIDUALLY PROGRAMMABLE VIA PIN JUMPERS (CONTACT TO OPEN OR CLOSE WHEN FAULT ACTIVATED)
 - 4 PROGRAMMABLE CONTACT - USER CONFIGURED FUNCTION VIA MEC 20 SOFTWARE (REFER TO MEC 20 LITERATURE)
 - 5 "GRD" CONNECTION TO BE MADE TO COMMON CHASSIS/ENCLOSURE GROUND BOND SYSTEM
 - 6 C282 OR NFPA 110 STANDARD FAULTS EXCLUDE ANALOG FAULTS OVER/UNDER VOLTAGE, OVER/UNDER FREQUENCY, OVERCURRENT, SPARE DIGITAL FAULT INPUTS #5-#12 AND PROGRAMMABLE OUTPUT #6 (I.E. MUST SPECIFY SECOND EXPANSION MODULE TO OBTAIN CONTACTS FOR THESE FAULTS).

G:\ENGINEER\PRODUCTS\MEC 20\MEC20_15_VSD

FIGURE #17 : EXPANSION OUTPUT MODULE CONNECTION DIAGRAM

The expansion module outputs are relay contacts which may be individually configured for normally open or normally closed contact position. Contact configuration is via circuit board mounted jumper pins and clips. Refer to FIGURE #18 for jumper pin location and configuration settings. Each output contact is rated maximum 0.5A 120Vac, 1.0A 30Vdc resistive.

Each expansion module also provides one programmable contact for desired control function. The programmable contact on the first expansion module (in the system) is referenced as "Programmable Output #5". On the second expansion module, the programmable contact is referenced as "Programmable Output #6". Refer to *Section 9.0* of this manual for programming functions and procedures for the programmable contact feature.

Note: The communication cable between the MEC 20 and the expansion module must be ordered separately.

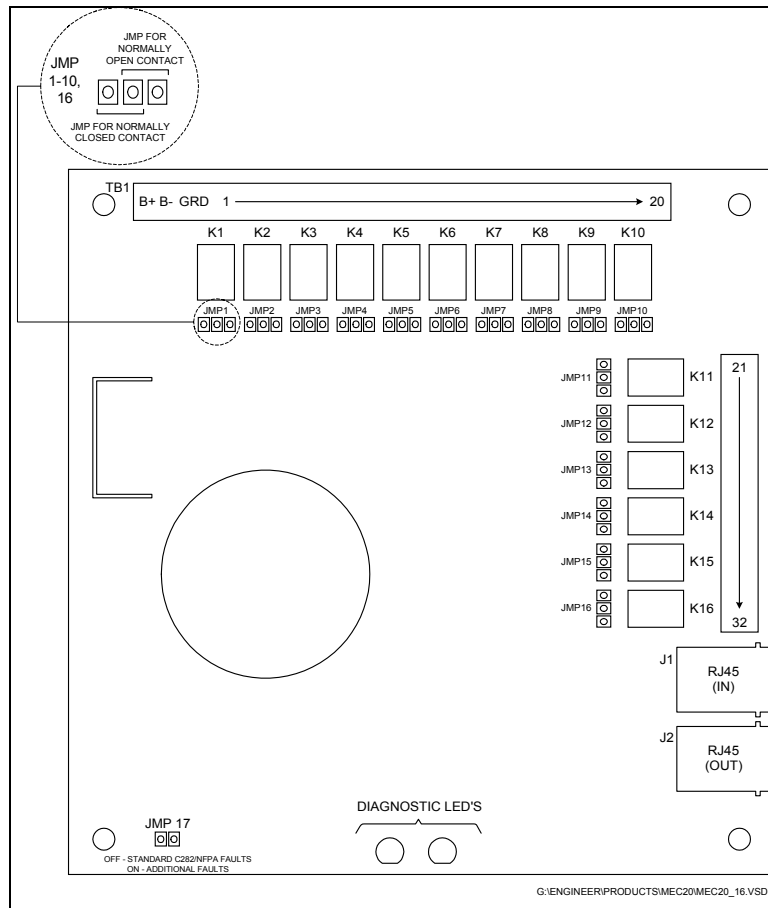

FIGURE #18: MEC 20 EXPANSION OUTPUT MODULE
PRINTED CIRCUIT BOARD LAYOUT

Diagnostic LED's are provided on each expansion module as shown in FIGURE #17. Their functions are described as follows:

WATCHDOG - This LED flashes on and off at a very high rate which indicates that the expansion module microprocessor is functioning normally.

MESSAGE - This LED flashes on and off at irregular intervals which indicates that the expansion module is correctly receiving all data messages from the MEC 20.

Two expansion modules may be connected to a single MEC 20 controller to provide a maximum of 32 output contacts. Two modules are interconnected together using a single communication cable to the MEC 20 controller. Refer to FIGURE #19 for interconnection details. The first expansion module addresses standard C282/NFPA110 MEC 20 fault circuits¹ and the second expansion module addresses all additional fault circuits. To select which faults are addressed by each expansion module, jumper pins and clips are provided on the circuit boards. Refer to FIGURE #18 for jumper pin location and configuration settings.

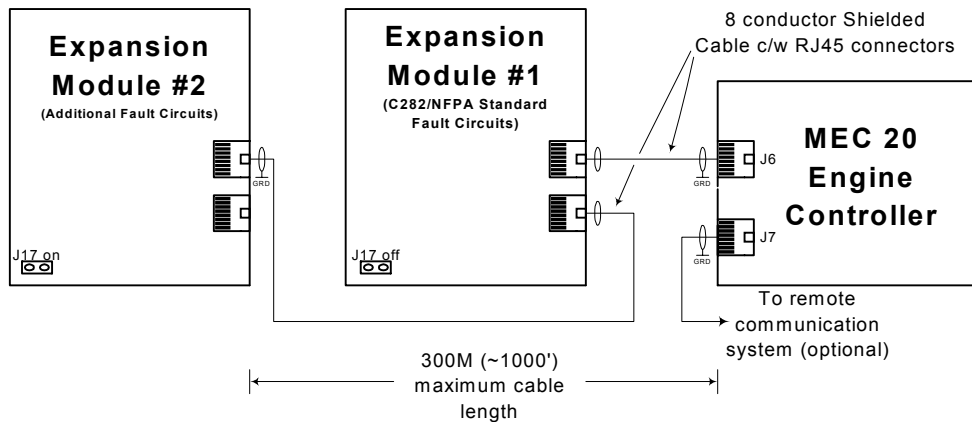

¹ C282 or NFPA 110 standard faults exclude analog faults Over/Under voltage, Over/Under Frequency, Overcurrent, spare digital inputs #5-#12 and programmable output #6 (i.e. must specify second expansion module to obtain contacts for these faults).

G:\ENGINEER\PRODUCTS\MEC20\MEC20_17.VSD

FIGURE #19 MEC 20 EXPANSION MODULE INTERCONNECTION DIAGRAM

8. EAP 110 REMOTE ANNUNCIATOR OPTION

An optional EAP 110 remote annunciator is available for the MEC 20 engine generator controller. The standard features of the **EAP 110** meet and exceed all requirements of NFPA 110, NFPA 99 & CSA 282-00 building code standards for Emergency Standby Generator systems. The design uses a 8 conductor RS 422 communication data link to provide the control & monitoring signals between the engine controller and remote annunciator. Up to 20 individual fault conditions are remotely monitored utilizing both visual LED lights & audible alarm annunciation. The **EAP 110** is DC powered from the same 12 or 24V engine starting battery as the engine controller is connected to. Two **EAP 110** annunciators can be interconnected together via the communication link to allow up to 40 remote annunciator points from a single engine controller.

For complete information on the **EAP 110** contact Thomson Technology to obtain the specific product documentation available.

Refer to FIGURE #20 for the EAP 110 remote annunciator connection diagram.

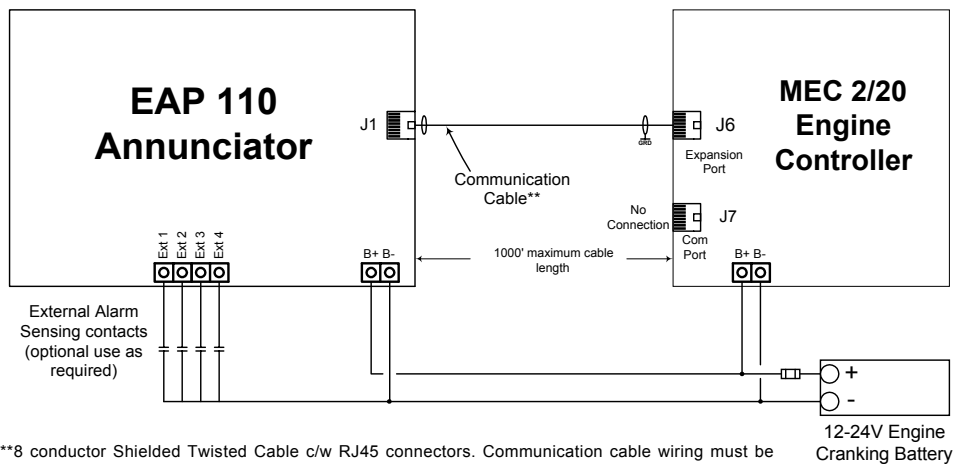

**8 conductor Shielded Twisted Cable c/w RJ45 connectors. Communication cable wiring must be suitably routed to protect it from sources of electrical interference. Refer to instruction manual for further information.

FIGURE #20 : EAP 110 REMOTE ANNUNCIATOR CONNECTION DIAGRAM

9. OPERATING INSTRUCTIONS

9.1. MEC 20 POWER-UP OPERATION SEQUENCE

When the MEC 20 is first energized with DC supply voltage at terminals B+ & B-, the controller will power-up into a fail-safe mode, preventing possible engine operation. The controller will default to an Emergency Stop failure mode and must be manually reset before the controller is put into normal operation. To reset the Emergency Stop condition, press the "OFF push-button first, then press both "INCREMENT" and "ENTER" push-buttons simultaneously. The controller will then reset, provided a *remote* emergency stop condition is not activated. The Utility Read to Load programmable output will energize if the remote start contact is open.

9.2. MEC 20 DISPLAY MENUS

The MEC 20 contains a Liquid Crystal Display (LCD) which is visible through the front lexan faceplate viewing window. The LCD has pre-programmed display screens and menus that may be selected by pressing the *ENTER* or *EXIT* push-buttons in succession until the desired screen or menu is displayed. The display screen types and order in which they are programmed are as follows:

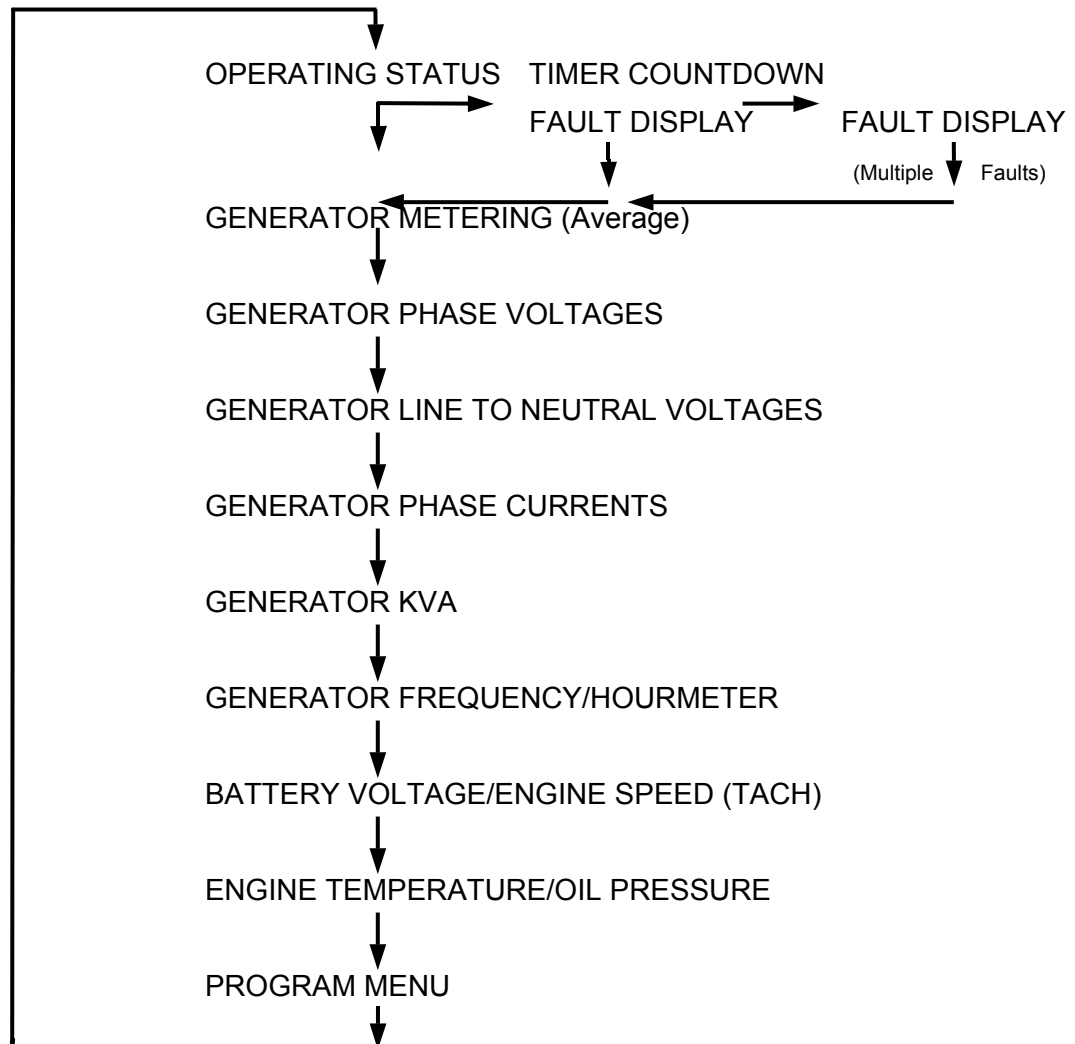

9.2.1. OPERATING STATUS MENU

The operating status menu provides the operator with detailed information as to the status of the engine-generator set.

NOTE:

The operating status screen may be momentarily replaced with a time delay countdown screen when a start or stop sequence is initiated. The display will automatically return to the previous menu following expiry of the timing sequence.

The operating status sub-menus are organized as follows:

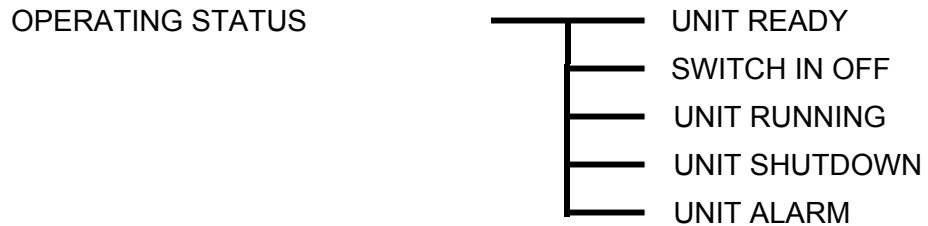

9.2.1.1. UNIT READY

This indicates that the controller is in “Auto” position and there are no active shutdowns or alarms.

9.2.1.2. SWITCH IN OFF

This indicates that the controller has been selected to the “off” position from the front panel keypad push-button.

9.2.1.3. UNIT RUNNING

This indicates that the engine is running and all conditions are normal.

9.2.1.4. UNIT SHUTDOWN

This indicates that a shutdown fault is active. The specific fault condition will be automatically displayed.

9.2.1.5. UNIT ALARM

This indicates that one or more alarm fault circuits are active. The display will automatically scroll through all active faults at a rate of every two seconds.

9.2.2. FAULT DISPLAY MENU

The fault display menu is automatically displayed when either an alarm or shutdown circuit is activated. The specific alarm or shutdown fault label will be displayed and if multiple alarm conditions are present, the display will automatically scroll through all active faults.

9.2.3. TIMER COUNTDOWN MENUS

Timer countdown menus are automatically displayed when a specific time delay function occurs during a control sequence. When a time delay

begins, the LCD display will indicate the time delay function name (i.e. ENGINE START DELAY) and the current time remaining in the countdown sequence. When the timing function has expired, the LCD display will automatically change to either the next timing sequence countdown display or return to the original system status menu.

LCD DISPLAY

**ENGINE START
DELAY^① 45 SEC^②**

- ① Displays specific time delay function currently in operation
- ② Displays current time in seconds or minutes that are left in the specific timing sequence.

NOTE:

During a timer countdown sequence, a different display screen may be selected by pressing the “ENTER” push-button.

The following timer countdown screens are provided:

ENG START DELAY	XX SEC.
CRANK PERIOD	XX SEC.
REST PERIOD	XX SEC.
STARTER RE-ENGAGE DELAY	XX SEC.
BYPASS DELAY	XX SEC.
COOLDOWN DELAY	XXXX SEC.
WARMUP DELAY*	XX SEC.
RETURN DELAY*	XXX SEC.
NEUTRAL DELAY*	XX SEC.

** Countdown screens only appear if Utility Gen Ready to Load outputs are programmed.

9.2.4. GENERATOR AC METERING

Four generator AC metering screens are provided as described below.

9.2.4.1. **AVERAGE VOLTAGE/CURRENT & FREQUENCY DISPLAY**

The generator average voltage/current & frequency metering screen allows the operator to simultaneously view all the listed parameters.

LCD DISPLAY

Vavg ^①	Aavg ^②	Freq ^③	600
	432	60.1	

① Displays the average generator voltage as follows:

3-phase system: AVERAGE LINE TO LINE VOLTAGE--
Phases AB, BC, CA

1-phase system: LINE TO LINE VOLTAGE--Phases A to B

② Displays the average generator current as follows:

3-phase system: AVERAGE LINE CURRENT--Phases A,B,C

1-phase system: AVERAGE LINE CURRENT--Phases A,B

③ Displays generator frequency in hertz (HZ). The frequency is displayed with a resolution of 1/10 of a hertz.

9.2.4.2. **GENERATOR KVA DISPLAY**

The generator's total power output in kilo-voltamperes (KVA) is displayed.

LCD DISPLAY

KVA
532.31

9.2.4.3. **GENERATOR PHASE VOLTAGE DISPLAY (LINE TO LINE)**

The generator phase voltage screen allows the operator to view the generator AC voltage on all 3 phases (or single phase system as selected).

LCD DISPLAY

Vab^①	Vbc^②	Vca^③
600	600	600

- ① Displays generator voltage as follows:
3-phase system: LINE TO LINE VOLTAGE--Phases A to B
1-phase system: LINE TO LINE VOLTAGE--Phases A to B
- ② Displays generator voltage as follows:
3-phase system: LINE TO LINE VOLTAGE--Phases B to C
1-phase system: LINE TO NEUTRAL VOLTAGE--Phases A-N
- ③ Displays generator voltage as follows:
3-phase system: LINE TO LINE VOLTAGE--Phases C-A
1-phase system: LINE TO NEUTRAL VOLTAGE--Phases B-N

9.2.4.4. **GENERATOR PHASE/NEUTRAL VOLTAGE DISPLAY (LINE TO NEUTRAL)**

The generator phase/neutral display allows the operator to view the generator line to neutral voltage for all 3 phases of the system. **Note:** The generators neutral must be connected to MEC 20 terminal TB1-VN and the “neutral connected” prompt in the main program menu must be selected as “Yes”.

LCD DISPLAY

Van^①	Vbn^②	Vcn^③
347	347	347

- ① Displays generator voltage Phase A to Neutral.
- ② Displays generator voltage Phase B to Neutral.
- ③ Displays generator voltage Phase C to Neutral.

9.2.4.5. **GENERATOR PHASE CURRENT DISPLAY**

The generator phase current screen allows the operator to view the generator load current on all 3 phases (or single phase system as selected).

LCD DISPLAY

Amps	a^①	b^②	c^③
	408	451	415

① Displays generator load current as follows:

3-phase system: PHASE A CURRENT

1-phase system: PHASE A CURRENT

② Displays generator load current as follows:

3-phase system: PHASE B CURRENT

1-phase system: PHASE B CURRENT

③ Displays generator load current as follows:

3-phase system: PHASE C CURRENT

1-phase system: not applicable

9.2.4.6. **GENERATOR FREQUENCY/HOURMETER DISPLAY**

The generator frequency and operating hours are displayed simultaneously on this screen.

LCD DISPLAY

FREQ	60.1 Hz^①
HOURS	56783 Hrs^②

① Displays generator frequency in hertz (HZ). The frequency is displayed with a resolution of 1/10 of a hertz.

② Displays unit operating hours

9.2.5. **ENGINE PARAMETER DISPLAY**

Two engine operating parameter screens are provided as described below.

9.2.5.1. **BATTERY VOLTAGE/ENGINE SPEED (tachometer)**

The battery voltage and engine speed are displayed simultaneously on this screen.

LCD DISPLAY



① Displays battery voltage in DC volts. The voltage is displayed with a resolution of 1/10 of a volt.

② Displays engine speed in revolutions per minute (RPM).

9.2.5.2. ENGINE TEMPERATURE/OIL PRESSURE

The engines operating temperature and oil pressure are displayed simultaneously on this screen.

LCD DISPLAY



① Displays engine temperature in either degrees Celsius or Fahrenheit (as selected).

② Displays engine oil pressure in either pounds per square inch (PSI) or in Kilopascals (KPA) (as selected).

9.2.6. PROGRAM MENU

The programming menu is used to access the MEC 20's programmable functions such as time delays, analog fault settings, digital fault settings and calibration.

Access to the programming *sub-menus* may only be obtained with a security password number. The sub menus are organized as follows:



LCD DISPLAY

<p>PROGRAM MENU?</p> <p>NO^⓪</p>
--

^⓪ Displays two messages that may be toggled between YES and NO by pressing the *INCREMENT* push-button. Their functions are described as follows:

NO Programming sub-menus are disabled when NO is displayed.

YES Programming sub-menus are enabled when YES is displayed and a valid password number is entered.

9.3. SEQUENCE OF OPERATION**9.3.1. GENERAL**

The MEC 20 Engine-generator controller is designed to start and stop an engine from either a local (“manual”) or remote (“automatic”) command. When this command is issued, the controller issues a run and crank output signal. The controller then monitors engine speed and when crank disconnect speed is reached, the crank signal is terminated. While the engine accelerates to normal speed, the controller continuously monitors the engines speed signal. Should the engine speed exceed the maximum predetermined setpoint, the overspeed shutdown fault circuit will activate, terminating the run signal. In addition to overspeed shutdown, the engine controller also monitors many other engine protection circuits and should they be activated, the engine will be stopped and/or alarm initiated. The engine will automatically stop for any shutdown condition, or when the remote and/or local start signal is removed. The engine controller operation includes time delay circuits for normal operating conditions such as start delays, cooldown and cranking periods.

9.3.2. MANUAL START/STOP SEQUENCE

When the “RUN” push-button on the front faceplate keypad is pressed, an ENGINE START DELAY timer will be initiated. **Note:** The start sequence will not be initiated if any shutdown fault condition is present. Once the engine start delay time expires, an engine RUN and CRANK output signal

will be initiated. **Note:** The RUN output may be programmed to only energize when a start signal is initiated and an engine speed signal is detected. Once the engine starts to turn over and begins to accelerate to nominal speed, the controllers speed sensor will terminate the CRANK output when engine speed reaches approximately 20% speed (i.e. CRANK DISCONNECT speed setpoint). Immediately upon reaching crank disconnect speed, the controller will initiate the BYPASS DELAY time delay function. Following the BYPASS DELAY time period (typically 10 seconds) all fault circuits programmed as BYPASS DELAY=YES will be activated. **Note:** All fault circuits programmed as BYPASS DELAY=NO are continuously armed irrespective of any operation sequence.

When the "OFF" push-button on the front keypad is depressed, the controllers RUN output will be immediately terminated which will initiate the engine to stop.

9.3.3. AUTOMATIC START/STOP SEQUENCE

When the controller is selected for automatic operation (via the front keypad push-button), the engine will automatically start upon activation of the remote start contact input. **Note:** The remote initiates a start sequence upon contact closure. Once the remote start signal is activated, the engine will start as per the sequence of operation described for the manual start sequence.

The automatic stop sequence will be initiated by removal of the remote start signal. Once the start signal is removed, a cooldown delay function will be initiated. Once the cooldown time delay period expires (typically programmed for 5 minutes), the controllers RUN output will be immediately terminated which will initiate the engine to stop.

9.3.4. AUTOMATIC FAULT SHUTDOWN SEQUENCE

When a fault circuit is programmed as a SHUTDOWN, the engine will immediately stop once the fault circuit is activated. **Note:** A specific shutdown fault may be programmed with a definite time *transient* delay period that must expire before the shutdown is activated. The stop

sequence will cause the controllers RUN output to be immediately terminated which will cause the engine to stop.

9.3.5. AUTO MAINS FAILURE (AMF) SEQUENCE

When the controller is applied in an Auto Mains Failure (AMF) application with a transfer switch, it must be wired as per FIGURE 21 shown at the end of this section. Programmable output #3 must be selected for Utility Ready To Load and programmable output #4 must be selected for Gen Ready To Load. Once the controller is programmed and wired as per FIGURE 21, the AMF sequence of operation will be as follows:

9.3.5.1. UTILITY NORMAL CONDITION:

- Remote Start input signal (MEC terminals 16 & 17) is not activated (i.e. Utility power is Normal)
- Utility Ready To Load output is energized (i.e. signal to transfer switch to transfer to utility power)
- Generator Ready To Load output is de-energized

9.3.5.2. UTILITY POWER FAILURE CONDITIONS:

- Remote Start input signal is activated (i.e. remote start contact closes when utility power fails, as sensed by utility voltage sensor)
- Engine starts following expiry of the Engine Start Delay timer (Utility Ready To Load output stays energized)
- Once the engine has started and the generator output rises above the programmed voltage and frequency limits, a warm-up timer is initiated.
- Once the warm-up timer expires the Utility Ready to Load output de-energizes and the NEUTRAL Delay timer is initiated.
- Once the NEUTRAL DELAY timer expires the Gen Ready to Load output energizes to signal the transfer switch to transfer to the generator supply. **Note:** The neutral delay

function is only operative with an electrically-held type transfer switch mechanism (i.e. electrical contactor type).

9.3.5.3. UTILITY POWER RETURN:

- Remote Start input signal is removed and the Return Delay timer is initiated (i.e. Utility Voltage returns to normal and the Utility voltage sensor contact opens)
- Once the Return Delay timer expires, the Generator Ready to Load output de-energizes and the Neutral Delay timer is initiated.
- Once the Neutral Delay timer expires the Utility Ready to Load output energizes to signal the transfer switch to transfer to the utility supply. **Note:** If the generator has a shutdown during the Return or Neutral Delay periods, the timers are bypassed, and the Utility Ready to Load output immediately energizes.
- The generator Cooldown Timer starts timing following expiry of the Return Delay timer.
- The generator stops following expiry of the Cooldown Timer.

9.3.5.4. MEC LOAD TEST PUSH-BUTTON OPERATION

NOTE:

The following sequence as described is applicable only if both “Utility Ready to Load” and Gen Ready to Load” outputs are programmed and used.

- When the MEC Load Test pushbutton is pressed, the controller’s logic will internally simulate receiving a remote start input.
- Engine starts following expiry of the Engine Start delay timer

- Once the engine has started and the generator output rises above the programmed voltage and frequency limits, a warm-up timer is initiated.
- Once the warm-up timer expires the Utility Ready to Load output de-energizes and the Neutral Delay timer is initiated.
- Once the Neutral Timer expires the Gen Ready To Load output energizes to signal the transfer switch to transfer to the generator supply. **Note:** if a generator shutdown occurs during a Load Test Operation, the Load Test mode will be de-activated.

When the MEC mode is re-selected to Auto Mode, the following sequence occurs:

- Simulated Remote Start input signal is removed
- Gen Ready To Load output de-energizes, and Neutral Delay timer is initiated.
- Once the Neutral Delay timer expires The Utility Ready To Load output energizes to signal the transfer switch to transfer to the utility supply.
- The generator Cooldown timer starts timing following the transfer to the utility supply.
- The generator stops following expiry of the Cooldown timer.

9.3.5.5. **NO LOAD TEST:**

To allow a timed No Load Test of the engine/generator set while using the AMF control application, a digital input contact from an external timer must be programmed for NO LOAD Test (*Refer to Section 10.5.8 for programming details*).

The sequence of operation for a No Load Test condition is as follows:

- With the utility supply normal and the generator stopped, a no load test sequence may be initiated by closing an external exercise timer contact to the programmed digital input for No Load Test.
- Once the external exercise timer contact closes, the engine will start and come-up to normal operating speed and voltage. The MEC will issue an alarm of a No Load Test condition. The connected transfer switch will remain on the utility and the generator will not transfer on load. **Note:** should the utility supply fail, the generator will automatically transfer on load.
- The engine will continue to run as long as the external exercise timer contact remains closed.
- Once the external exercise timer contact opens, the engine will continue to run for its cooldown time as programmed, then it will automatically stop.

TYPICAL MEC 2 / MEC 20 AUTO MAINS FAILURE (AMF) APPLICATION

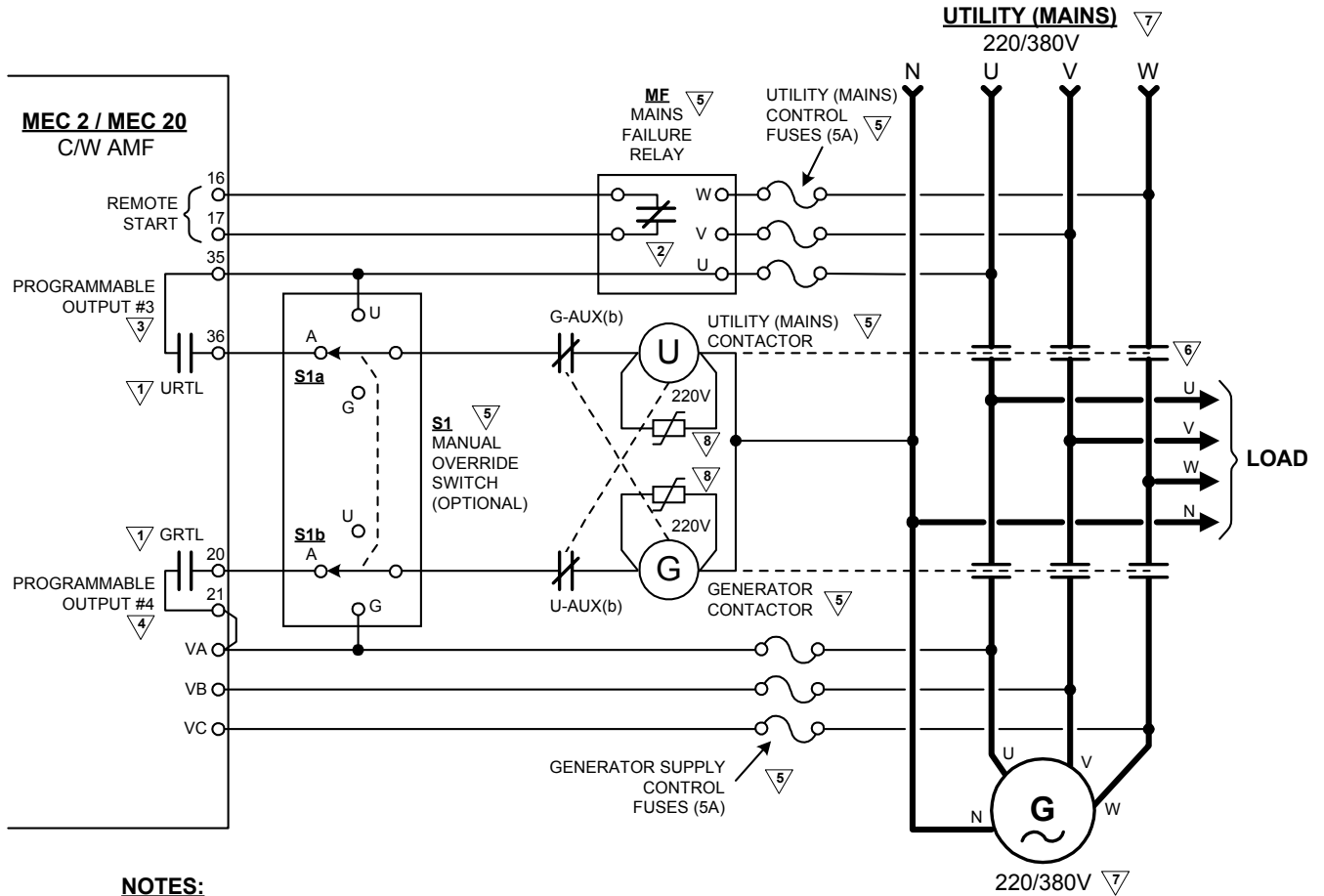

NOTES:

- 1 CONTACTS RATED 10A, 240VAC RESISTIVE
- 2 MAINS FAILURE CONTACT CLOSES WHEN VOLTAGE DROPS BELOW SETPOINT
- 3 PROGRAMMABLE OUTPUT #3 MUST BE PROGRAMMED FOR "UTILITY READY TO LOAD"
- 4 PROGRAMMABLE OUTPUT #4 MUST BE PROGRAMMED FOR "GENERATOR READY TO LOAD"
- 5 ALL COMPONENTS SHOWN EXTERNAL TO THE MEC 2 / MEC 20 ARE OPTIONAL ITEMS
- 6 3 POLE CHANGEOVER SWITCH SHOWN
- 7 FOR OTHER SYSTEM VOLTAGE APPLICATIONS, CONSULT TTI FACTORY
- 8 AC COIL SPIKE SUPPRESSION DEVICES ARE REQUIRED

G:\ENGINEER\PRODUCTS\MEC2\MEC2_10.VSD REV. 0 01/11/20

FIGURE 21

9.4. CONTROL PUSH-BUTTONS

The following control push-buttons are located on the front faceplate keypad.

9.4.1. RUN/OFF/AUTO/LOAD TEST

9.4.1.1. ***RUN***

In this position, the engine will start and operate continuously providing no shutdown circuits are active. All protective circuits will be operative in this mode. There will be no cooldown cycle at the end of a manual run sequence.

9.4.1.2. ***OFF***

This position immediately stops the engine and locks it out from operation. The OFF position also allows any shutdowns to be reset.

9.4.1.3. ***AUTO***

In this position, starting and stopping of the engine will be controlled by a remote contact. When the remote start signal is removed the engine will continue to run for the cooldown period (if selected) then stop. Re-selecting the *Off* position will stop the engine immediately, even if the cooldown period is not complete.

9.4.1.4. ***LOADTEST***

NOTE:

The control feature is only operative if used in the AMF application or if one of the programmable output contacts is configured for "ATS Test" and a remote transfer switch is interconnected with remote testing circuitry.

In this position, a signal will be issued to a remote transfer switch to permit an automatic engine start and load transfer.

Once initiated, the engine will receive a start signal from the transfer switch and upon the generator reaching nominal voltage and frequency levels, a load transfer will be initiated. The generator set will remain running on load until a different operating mode is selected or the generator set develops an alarm or shutdown condition.

9.4.2. EMERGENCY STOP PUSH-BUTTON

This push-button will cause the engine to immediately stop and be locked out from operation. The engine cannot be restarted in this mode until the controller has been reset.

9.4.3. FAULT RESET FUNCTION

To initiate a fault reset function, both “INCREMENT” and “ENTER” push-buttons must be simultaneously pressed. This function resets the controller when in a shutdown mode.

NOTE:

To initiate a reset command, the engine must come to a complete stop and the controller’s switch must be placed in the *Off* position.

9.4.4. HORN SILENCE FUNCTION

To initiate a horn silence function, both “EXIT” & “DECREMENT” push-buttons must be simultaneously pressed. This function will silence the audible alarm horn without resetting the fail condition.

9.4.5. LAMP TEST

A lamp test feature is provided to test all software controlled LED lights as well as the LCD display. To activate the lamp test feature, simultaneously push the INCREMENT and DECREMENT push-buttons. The LED’s and LCD display will illuminate for approximately 2 seconds then return to their original status. **Note:** The emergency stop LED will not be activated by a software initiated test as it is controlled via independent hardware circuitry only.

10. PROGRAMMING INSTRUCTIONS

10.1. SECURITY PASSWORDS

Access to the programmable parameters of the MEC 20 Controller is via a security password number. Three security password levels are provided as described below:

10.1.1. READ ONLY MODE

User can view the programmable parameters only and cannot change any values. The factory default number for the read-only level is one (1).

10.1.2. READ / WRITE MODE

User can view and modify any programming parameter as required. The Factory default number for the read/write level is two (2).

10.1.3. MASTER READ / WRITE MODE

User can view/modify any programming parameter as well as view/modify the security password level numbers. Contact TTI factory for master password if required.

To enter the programming mode, follow the procedure as shown:



PROGRAM MENU?
YES

Select the Program Menu by scrolling through the display menus using the "ENTER" push-button. When displayed, use the INCREMENT push-button to select the YES prompt and push the ENTER button

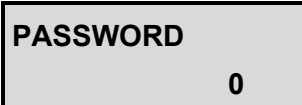

PASSWORD
0

Use the INCREMENT or DECREMENT push-buttons to ramp the displayed number up or down to the desired password access number. Press the ENTER push-button when the correct number is displayed.

NOTE:

If an invalid number is entered, programming access will be denied. To exit the programming mode, press the EXIT push-button for more two seconds until the display changes.

10.2. BASIC PROGRAMMING OPERATION

Once the correct password number is entered, the user may choose one of four separate programming menus as shown below:

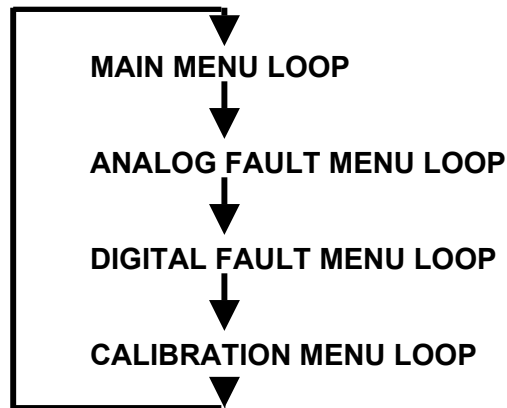

The MAIN MENU message will be displayed immediately upon entering the programming mode. To select the desired programming menu, press the INCREMENT push-button to scroll through the available menu types and once displayed, press the ENTER push-button to select the specific program menu.

When the programming mode is accessed, the programming parameters will be displayed in the same order as the Programming Sheets. To skip over parameters that do not require changes, push and hold the ENTER push-button until the desired function is displayed. The EXIT push-button may be used to scroll backwards through the programming parameter loops.

To change a programmed parameter, use the INCREMENT or DECREMENT push-buttons to scroll through the available options or to adjust a value up or

down to the desired number. When the desired option or number is displayed, press the ENTER push-button to accept the new value.

NOTE:

If the programming mode is terminated before the last change had been entered, the programming parameter will remain unchanged.

To exit the programming mode, press the EXIT push-button and hold for two seconds.

The controller will automatically exit the Program Mode when an internal timer set for 999 seconds, expires from when a key press was last received by the controller.

Note: The display menu will automatically revert to a low power “sleep” mode following the expiry of the 999 second internal timer.

10.3. MAIN PROGRAMMING MENU

The main programming menu contains general system configuration programming such as system input voltages, currents, transformer ratios, as well as standard operating time delay functions. The programming prompts are listed in order as they appear in the MEC 20 software. To program the specific MAIN MENU items, refer to the following descriptions:

10.3.1. NODE ADDRESS

Set to unique controller address (1-255) for use with network connected MEC 20 controllers.

Note: This programming feature is only active when the remote communication option is enabled. Default setting for single MEC 20 applications is 1.

10.3.2. SYSTEM VOLTAGE

Set to nominal system voltage as expressed in “phase to phase” voltage (i.e. a 347/600 volt system would be entered as “600”). The programmable range of values is 120V-15,000V.

10.3.3. SYSTEM FREQUENCY

Set to nominal system frequency of either 50 HZ or 60 HZ.

10.3.4. SYSTEM PHASES

Set to match the power distribution system used on the generator set (i.e. either single phase or 3 phase system).

10.3.5. NEUTRAL CONNECTED

Set to “Yes” if generator’s neutral conductor is connected to the MEC 20 controller terminal TB1-VN and it is desired to display line-neutral AC voltages for a 3 phase, 4 wire system.

10.3.6. VOLTAGE SENSING RATIO

For direct voltage sensing wiring connections from 208 to 600 volts, enter “1” (i.e. a ratio of “1:1”). When potential transformers are utilized for voltage sensing, enter the calculated transformer ratio (e.g. when using 600:120 transformers, enter a number of “5”).

10.3.7. CURRENT SENSING RATIO

For current sensing wiring connections from current transformers (CT’s), enter the calculated CT ratio (e.g. when using a 600:5 CT, enter a number of “120”).

10.3.8. TEMPERATURE SCALE

Select the desired type of engineering units for the engine temperature display and analog setpoints as provided: Degrees Fahrenheit or Degrees Celsius.

Note: Alarm setpoints do not automatically re-configure when changing between Fahrenheit or Celsius.

10.3.9. PRESSURE SCALE

Select the desired type of engineering units for the engine pressure display and analog setpoints as provided: Pounds per square inch (PSI) or Kilopascals (KPA).

Note: Alarm setpoints do not automatically re-configure when changing between PSI and KPA.

10.3.10. START DELAY

Select desired engine start delay time in seconds. If engine start delay is not required, set to zero.

Note: If preheat and /or prelube functions are utilized, the engine start delay time should be set as required for these functions.

10.3.11. CRANK TIME

Select desired cranking time in seconds. If cycle cranking is selected, this time will be the crank time period on each attempt.

10.3.12. REST TIME

Select desired rest time between cranking attempts. (Only valid if multiple crank attempts are selected).

Note: This value will be ignored if only one attempt has been programmed.

10.3.13. STARTER RE-ENGAGE DURATION

This feature will check for a speed signal while cranking. If no speed signal is sensed, the controller assumes that the engine starter is not turning the engine over (for whatever reason), and disengages it after the programmed time delay, and re-engages it again. This process will repeat until a speed signal is sensed or cranking time expires, whichever occurs first. If a speed signal is sensed, the cranking output will be maintained until the unit starts or an overcrank condition occurs. Set time in seconds for desired sampling period, i.e. a setting of 5 seconds will attempt cranking for 5 seconds after which time if no speed signal is detected, the crank output will be removed for a preset 1 second delay before re-engaging.

Note: This action is more than a cycle cranking function and is independent of the number of attempts selected, therefore, the "crank" time should be considered. To disable this feature, set to zero.

10.3.14. NUMBER OF CRANK CYCLES

Set to the number of cranking cycles required. (Zero will default to one.)

10.3.15. BYPASS DELAY

This setting is the time period that affected Alarm or Shutdown inputs will be ignored after crank disconnect, allowing the engine to settle into its normal operating mode (i.e. proper oil pressure, etc.). This is typically set to 10 seconds.

10.3.16. COOLDOWN TIME

Set to desired cooldown time in seconds. Up to 9999 seconds of cooldown time may be programmed. Set to zero if not required. **Note:** If the controller is used in an AMF application it is recommended to set the cooldown timer to a minimum of 10 seconds to allow the generator to transfer Off Load before enabling the cooldown time. (Ensures the load is transferred off of generator prior to stopping the engine.)

10.3.17. NOMINAL ENGINE RPM

Set to the nominal engine speed in revolutions per minute (RPM).

10.3.18. FLYWHEEL TEETH

Set to the number of ring gear teeth on the engine flywheel. The magnetic pick-up must be installed to sense the same teeth for speed sensing as programmed.

10.3.19. CRANK DISCONNECT SPEED

Set crank disconnect speed in percentage of nominal speed, i.e. 30% or 540 RPM on a 1800 RPM engine.

10.3.20. OVERSPEED

Set overspeed shutdown point in percentage of nominal speed (i.e. 110% or 1980 RPM on a 1800 RPM engine).

10.3.21. OVERSPEED TRANSIENT DELAY

Select desired overspeed transient delay time in seconds. Time setting may be entered in tenths of seconds.

10.3.22. RUN OUTPUT FAIL-SAFE

When enabled, this feature will inhibit the run output until the controller receives a speed sensing signal, thus preventing possible damage from

starting the engine with no speed sensing for crank disconnect and overspeed. If selected, ensure that the speed signal is not less than 3.0Vac from the magnetic pick up while the engine is cranking. **Note:** If this feature is disabled, no overspeed protection or crank disconnect will be provided if the speed signal fails. Should the user elect to disable this feature Thomson Technology strongly recommends that backup crank disconnect protection and additional overspeed protection is utilized.

NOTE:

The run output Fail-safe feature will be factory programmed as enabled. The user of this equipment may elect to change this feature dependent upon site conditions and does so at their discretion.

10.3.23. LOSS OF SPEED SIGNAL

Select the desired action (i.e. alarm or shutdown) when a loss of speed signal is detected during operation. **Note:** A loss of speed signal must be detected for longer than 2 seconds to initiate the desired action.

10.3.24. COMMON FAIL FOR “NOT IN AUTO” FUNCTION

Use this function to select if a “common fail” alarm condition is to be activated when the engine controller is not selected for “automatic” operation.

10.3.25. HORN FOR NOT IN AUTO

The Horn may be programmed to sound when the controllers operating mode is switched from the Auto position. If the Horn is not to sound, select program setting “no”.

10.3.26. WARM-UP DELAY

The WARM-UP Delay programming menu appears when the Gen Ready To Load programmable output is selected as is typically used in an AMF application. Set to the desired time in seconds, which the generator requires to effectively “warm-up” before accepting load. This

is typically set for 3 seconds. The warm-up Delay is initiated once the generator output rises above programmed voltage and frequency limits (per the analog programming menus). Refer to *Section 9.3.* for further details on this timing function.

10.3.27. NEUTRAL DELAY

The Neutral Delay programming menu appears when the Utility Ready To Load programmable output is selected as is typically used in an AMF application. The Neutral Delay timer is initiated when transferring between the available sources. When transferring from the utility supply to the generator supply, the Neutral Delay timer will start when The Utility Ready To Load output de-energizes. Once the Neutral Delay time period expires, The Generator Ready To Load output will then be energized. The similar sequence will occur when transfer in the opposite direction. The purpose of the Neutral Delay timer is to prevent out of phase transfers, which may be caused by a fast transfer and the two sources of supply are out of synchronism. The Neutral Delay timer ensures the load voltages decay before the transfer is initiated.

Set to the desired time in seconds. The Neutral Delay timer is typically set for 3 seconds. Refer to *Section 9.3* for further details on this timing function.

NOTE:

The Neutral Delay feature is only effective when an electrically held “contactor-type” transfer switch is connected. Contact Thomson Technology for further application information on use with other types of transfer switch mechanisms.

10.3.28. RETURN DELAY

The Return Delay programming menu appears when the Utility Ready To Load programmable output is selected as is typically used in an AMF application. The Return Delay is initiated once the remote start

signal is removed, signaling that utility power is now available. Once the Return Delay timer expires, the Generator Ready To Load output will be removed, and the Utility Ready To Load output energizes to signal transfer the load back to the utility supply. The purpose of the Return Delay timer is to ensure that the utility power has returned to a steady state for the selected time period before the load is transferred back to the utility supply. The Return Delay timer is typically set for 120 seconds. Refer to *Section 9.3* for further details on this timing function.

10.3.29. PROGRAMMABLE OUTPUT CONTACTS

Select the desired function that will activate the designated programmable relay output contact. One of the following functions may be selected:

Note: Programmable output contacts #5 and #6 are located on external expansion output module as optionally available. Refer to *Section 7.0* for additional information.

PRE/POST/CYCLIC LUBE CONTROL	IDLE CONTROL
OVERCURRENT	EPS SUPPLYING LOAD
ENERGIZE TO STOP	GEN READY TO LOAD
AIR FLAP	UTILITY READY TO LOAD
OIL BYPASS TIMER COMPLETE	DIGITAL FAULTS #1 – 12
COMMON FAIL	OVERSPEED
SWITCH NOT IN AUTO	LOSS OF SPEED SIGNAL
ENGINE READY	LOW BAT VOLTAGE
ENGINE RUN (FUEL)	HIGH BAT VOLTAGE
PREHEAT	WEAK BAT VOLTAGE
ENGINE RUNNING	LOW OIL PRESS #1 ALARM
ATS TEST	LOW OIL PRESS #2 SHUTDOWN
COMMON ALARM	HIGH ENG TEMP #1 ALARM
COMMON SHUTDOWN	HIGH ENG TEMP #1 SHUTDOWN

CAUTION!!!

The programming function selected must co-ordinate with external control wiring prior to energizing the control system. Failure to do so may cause severe equipment damage.

10.3.30. AUTO CALLOUT

When the remote communication option is enabled, this programming prompt will appear. The controller can be programmed for the desired type of common fault (i.e. common shutdown, common fail or common alarm) which will initiate an automatic call out to a remote communication device.

10.3.31. POST-LUBE DURATION

Program the desired post lube duration in minutes (0 - 999) for *postlube duration* function.

Note: Lube functions are disabled in *Off* and whenever the engine is above *crank disconnect* speed.

10.3.32. CYCLE LUBE INTERVAL

A cyclic lube function can be set up to circulate oil through the engine several times per day while the engine is not running. A non-zero post-lube duration must be entered to enable the lube output. Select the desired cycle lube interval (i.e. time on/ time off) in minutes (1-9999).

10.3.33. CYCLE LUBE DURATION

Once the lube interval timer has expired it resets itself and starts the lube pump for this time duration. If the *cycle-lube duration* is longer than the *lube interval*, the pump will run continuously when the engine is not running. The pre-lube output is also energized during the engine start delay and crank cycles, and de-energized when the engine reaches crank disconnect speed. Select the desired cycle lube duration (i.e. on time) in minutes (0-999).

10.3.34. RESET RUN HOURS

The controller's engine hourmeter may be reset to zero hours when yes is programmed. **Note:** This programming prompt is only accessible while using the "Master" programming security password.

10.4. ANALOG FAULT PROGRAMMING MENU

To program the controller's analog fault circuits, refer to the following descriptions.

Note: certain programming functions listed below may not be provided for a specific fault. Refer to *Section 11.3* for a table indicating programmable features provided.

10.4.1. LEVEL

This setting determines the actual analog signal setpoint at which the selected fault type will be activated. **Note:** For AC voltage fault circuits, two levels (i.e. pick-up & drop-out) must be programmed.

10.4.2. ACTION

This setting allows a fault circuit to be programmed as either an *alarm* or a *shutdown*.

10.4.3. ALARM LATCH

If an alarm fault was programmed, it may be selected as a "latching" alarm or "non-latching". When "latching" is selected, it will not un-latch until a reset command clears it. **Note:** This programming prompt only appears if alarm faults are programmed. Shutdown faults are automatically set as latching.

10.4.4. BYPASS ON START DELAY

This allows the alarm or shutdown circuit to be disabled until after the bypass timer has expired. Fault circuits that are not delayed will be enabled at all times (i.e. engine running or stopped).

10.4.5. TRANSIENT DELAY TIMES

This allows the selected fault circuit to be inhibited from being activated until the specified time delay period has expired. Delay times from 0.0 to 999.9 seconds are available by entering the time required.

10.5. DIGITAL FAULT PROGRAMMING MENU

To program the controller’s digital fault circuits, refer to the following descriptions.

10.5.1. DIGITAL FAULT LABEL

To select the desired fault label description, use the “increment” key to scroll through the available labels. The digital fault labels are stored in non-volatile memory and are as follows:

- | | |
|------------------------|--------------------|
| AIR DAMPER TRIPPED | HIGH OIL TEMP |
| BAT CHARGER INPUT FAIL | HIGH WINDING TEMP |
| BAT CHRG TROUBLE | IDLE |
| BREAKER TRIPPED | LOW COOLANT LEVEL |
| DC FAIL | LOW ENGINE TEMP |
| FAILED TO SYNC | LOW FUEL PRESS |
| GEN BREAKER OPEN | LOW FUEL LEVEL |
| GROUND FAULT | LOW OIL LEVEL |
| HIGH BEARING TEMP | LOW OIL PRESSURE |
| HIGH COOLER VIBRATION | REMOTE EMERG. STOP |
| HIGH ENGINE TEMP | REVERSE POWER |
| HIGH ENGINE VIBRATION | BASIN RUPTURE |
| HIGH FUEL LEVEL | ATS IN BYPASS |
| HIGH OIL LEVEL | FUEL LEAK |
| NO LOAD TEST | LOW FUEL PRESS |
| *HIGHINTKMANFTEMP | BAT CHARGER FAIL |
| VENT DAMPER FAIL | |
| HIGH FUEL LEVEL | |
| FAIL TO SYNC | |
- “Blank” (i.e. no text for unused inputs)

Once the desired fault label is selected, press the “enter” key to accept the selection.

WARNING!!!

The digital fault label programming must match with the external control wiring to the controller. Failure to do so may cause severe equipment damage.

10.5.2. ACTION

This setting allows a fault circuit to be programmed as either an *alarm* or a *shutdown*.

Note: All activated alarm and shutdown faults will energize the “common fail” circuit and sound the alarm horn.

10.5.3. ALARM LATCH

If an alarm fault was programmed, it may be selected as a “latching” alarm or “non-latching”. When latching is selected, it will not unlatch until a reset command clears it. **Note:** This programming prompt only appears if alarm faults are programmed. Shutdown faults are automatically set as latching.

10.5.4. POLARITY

This setting allows the digital fault circuit to be set for *Open to Fail* or *Close to Fail* sensing contacts.

10.5.5. BYPASS ON START DELAY

This allows the alarm or shutdown circuit to be disabled until after the bypass timer has expired. Fault circuits that are not delayed will be enabled at all times (i.e. engine running or stopped).

10.5.6. TRANSIENT DELAY TIMES

This allows the selected fault circuit to be inhibited from being activated until the specified time delay period has expired. Delay times from 0.0 to 999.9 seconds are available by entering the time required.

10.5.7. IDLE CONTROL DIGITAL INPUT PROGRAMMING

When a digital input is programmed as Idle function, the following settings must be programmed to ensure correct operation.

ACTION

Alarm

ALARM LATCH	No
POLARITY	Close
BYPASS ON START	No
TRANSIENT TIME	0.1

NOTE:

A programmable output must also be programmed for IDLE to enable correct operation. Refer to *Section 5.2.2* for further details

10.5.8. NO LOAD TEST CONTROL DIGITAL INPUT PROGRAMMING

When a digital input is programmed as NO LOAD TEST, the following settings must be programmed to ensure correct operation.

ACTION	Alarm
ALARM LATCH	No
POLARITY	Close or Open (dependent on external circuit used)
BYPASS ON START	No
TRANSIENT TIME	0.1

The No Load Test digital input feature is typically used in an AMF application where it is required to do an automatic timed No Load Test of the engine/generator set. A contact from an external exercise clock timer is required to be connected to the digital input circuit which is programmed for “No Load Test”.

Refer to *Section 9.3.6* for details on sequence of operation.

10.6. CALIBRATION MENU

10.6.1. GENERAL

AC Voltage, AC current and battery voltage analog circuits are factory calibrated before the product is shipped therefore these circuits should not require any field calibration. Should field calibration be required refer to the applicable procedure as described further in this section.

Engine oil pressure and engine temperature analog circuits are not factory calibrated and therefore require field calibration before the equipment is placed into service. Refer to *Section 10.6.9 & 10.6.10* for detailed information on field calibration procedures required.

WARNING!!!

Failure to field calibrate and validate the correct operation of the engine oil pressure and engine temperature analog circuits on the equipment may result in severe equipment failure or damage.

10.6.2. VOLTAGE SENSING CALIBRATION (PHASE TO PHASE OR PHASE TO NEUTRAL)

**VOLTS AB^① ZERO^②
99^③ 600V^④**

- ① Displays the generator's phase voltages to be calibrated.
- ② Displays the type of calibration function, either ZERO or SPAN.
- ③ Displays the calibration correction factor number (0-255) used to obtain the correct voltage reading. **Note:** To correctly calibrate any of the voltage sensors, the ZERO function must be calibrated before the SPAN function.
- ④ Displays the actual voltage measurement that will be the same value as shown on the MEC 20 display menus for generator supply. This voltage reading may be calibrated higher or lower by changing the correction factor number.

10.6.3. VOLTAGE CALIBRATION PROCEDURE

NOTE:

To accurately calibrate the MEC 20's voltage sensors, an external test voltage meter is required, with an accuracy of 0.5% or better.

Note: Zero Calibration must be completed before Span Calibration.

To calibrate the generator supply voltage sensors, perform the following procedure:

10.6.3.1. ZERO CALIBRATION

Connect an external AC voltmeter of adequate voltage range and accuracy to the MEC 20 controller terminals associated with the voltage phases to be calibrated. With the generator stopped, confirm there is Zero volts on the phases to be calibrated.

In the programming mode, scroll to each of the desired generator supply voltage phases (i.e. phase to phase or phase to neutral) with the ZERO function selected.

Use the INCREMENT or DECREMENT push-buttons to adjust the correction factor number to obtain zero volts on the right hand side of the display as confirmed with the external voltmeter. The factory default correction factor is 127. Increasing this will raise the displayed value, conversely decreasing this value will decrease the displayed value. **Note:** Adjusting the ZERO function with voltage applied will result in non-linear voltage readings.

With the correct voltage displayed, press the ENTER push-button to accept the correction factor number. Record the correction factor number on the MEC 20 programming sheet for future reference.

Repeat the above procedure for all remaining phases of the generator supply as required.

10.6.3.2. SPAN CALIBRATION

Energize the generator supply voltage to the controller at nominal level. **Note:** It may be necessary to program the optional under and over voltage shutdowns as alarms to ensure the generator will continue to operate during calibration. Caution must be taken to ensure the generator output voltage is set within nominal limits.

In the programming mode, scroll to the desired generator supply voltage phases with the SPAN function selected.

Connect an external AC voltmeter of adequate voltage range and accuracy to the MEC 20 controller terminals associated with the voltage phases to be calibrated.

WARNING!!!

Voltage sensing circuits are capable of lethal voltages while energized. Standard safety procedures should be followed and be performed by qualified personnel only. Failure to do so may cause personnel injury and/or death.

Use the INCREMENT or DECREMENT push-buttons to adjust the correction factor number while observing the displayed voltage level on the MEC 20. Adjust the correction factor number to obtain an identical voltage reading as measured with the external AC voltmeter.

With the correct voltage displayed, press the *ENTER* push-button to accept the correction factor number. Record the correction factor number on the MEC 20 programming sheet for future reference if required.

Repeat the above procedures for all remaining phases of the generator supply as required.

NOTE:

Once the span calibration setting has been completed, re-confirm the zero calibration points. If the zero calibration setpoint needs further adjustment, the span calibration point must also be re-calibrated.

10.6.4. CURRENT SENSING CALIBRATION

**CURRENT A^① ZERO^②
99^③ 350A^④**

^① Displays the generator's load current (phase A, B or C) to be calibrated.

- ② Displays the type of calibration function, either ZERO or SPAN.
- ③ Displays the calibration correction factor number (0-255) used to obtain the correct current reading. **Note:** To correctly calibrate any of the current sensors, the ZERO function must be calibrated before the SPAN function.
- ④ Displays the actual current measurement that will be the same value as shown on the MEC 20 display menus for generator supply. This current reading may be calibrated higher or lower by changing the correction factor number.

10.6.5. CURRENT CALIBRATION PROCEDURE

NOTE:

To accurately calibrate the MEC 20's current sensors, an external test AC ammeter and current clamp is required, with an accuracy of 0.5% or better.

Note: Zero calibration must be completed before span calibration.

To calibrate the generator supply current sensors, perform the following procedure:

10.6.5.1. ZERO CALIBRATION

Connect an external AC ammeter with current clamp of adequate current range to the MEC 20 controller terminals associated with the current phases to be calibrated. With the generator stopped, confirm there is "0" current on the phases to be calibrated. In the programming mode, scroll to each of the desired generator supply current phases with the ZERO function selected.

Use the INCREMENT or DECREMENT push-buttons to adjust the correction factor number while observing the displayed current level. Adjust the correction factor number just until "0" amps is obtained.

With the correct current displayed, press the ENTER push-button to accept the correction factor number. Record the

correction factor number on the MEC 20 programming sheet for future reference.

Repeat the above procedure for all remaining generator current phases.

10.6.5.2. **SPAN CALIBRATION**

Apply 50%-100% load to the generator set. **Note:** It is recommended to load the generator set to 100% rated load for calibration purposes to obtain good accuracy throughout the full span of operation.

NOTE:

Do not exceed the current rating of the CT. Non-linear output of the CT will result when the secondary current exceeds 5 amps and will similarly effect the MEC 20 displayed values.

In the programming mode, scroll to the desired generator supply current phases with the SPAN function selected.

Connect an external AC ammeter and current clamp of adequate current range to the MEC 20 controller terminals associated with the current phases to be calibrated.

WARNING!!!

Never open circuit an energized CT as extreme high voltages may result which may cause serious injury or death. Standard safety procedures should be followed and be performed by qualified personnel only. Failure to do so may cause personnel injury and/or death.

Use the INCREMENT or DECREMENT push-buttons to adjust the correction factor number while observing the displayed current level on the MEC 20. Adjust the correction factor

number to obtain an identical current reading as measured with the external AC ammeter.

With the correct current displayed, press the *ENTER* push-button to accept the correction factor number. Record the correction factor number on the MEC 20 programming sheet for future reference if required.

Repeat the above procedures for all remaining generator current phases.

NOTE:

Once the span calibration setting has been completed, re-confirm the zero calibration points. If the zero calibration setpoint needs further adjustment, the span calibration point must also be re-calibrated.

10.6.6. BATTERY VOLTAGE CALIBRATION

BAT VOLTS SPAN^①

99^② 24.6V^③

- ① Displays the type of calibration function (SPAN).
- ② Displays the calibration correction factor number (0-255) used to obtain the correct voltage reading.
- ③ Displays the actual battery voltage measurement that will be the same value as shown on the MEC 20 display menu. This voltage reading may be calibrated higher or lower by changing the correction factor number.

10.6.7. BATTERY VOLTAGE CALIBRATION PROCEDURE

NOTE:

To accurately calibrate the MEC 20's battery voltage sensor, an external test DC voltmeter is required, with an accuracy of 0.5% or better.

To calibrate the battery voltage sensor, perform the following procedure:

10.6.7.1. SPAN CALIBRATION

Energize the battery supply voltage to the controller and connect the external test DC voltmeter to the battery terminals, B+ and B-.

In the programming mode, scroll to the battery span calibration point.

Use the INCREMENT or DECREMENT push-buttons to adjust the correction factor number while observing the displayed battery voltage level on the MEC 20. Adjust the correction factor number to obtain an identical voltage reading as measured with the external DC voltmeter.

With the correct voltage displayed, press the *ENTER* push-button to accept the correction factor number. Record the correction factor number on the MEC 20 programming sheet for future reference if required.

10.6.8. ENGINE TEMPERATURE & OIL PRESSURE CALIBRATION

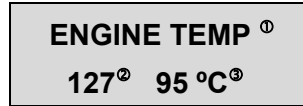

^① Displays the type of calibration function.

^② Displays the calibration correction factor number (0-255) used to obtain the correct Temperature or Pressure reading.

^③ Displays the actual temperature or pressure measurement that will be the same value as shown on the MEC 20 display menus. This reading may be calibrated higher or lower by changing the correction factor number.

10.6.9. TEMPERATURE CALIBRATION PROCEDURE

Before the equipment is put into final operating service, the engine temperature analog circuit must be field calibrated to meet the performance accuracy as specified, to ensure correct operation. The engine temperature analog circuit must be calibrated with the engine

temperature sender supplied with the controller and mounted on the engine.

WARNING!!!

Failure to field calibrate and validate the correct operation of the temperature analog circuit on the equipment may result in severe equipment failure or damage.

To calibrate the MEC 20 temperature sensor, perform the following procedure:

NOTE:

To accurately calibrate the MEC 20's temperature sensor, an external temporary engine mounted temperature gauge is required. The external temperature gauge should be connected as close as possible to the temperature sender for the MEC 20.

The calibration procedure is to be done only at a single point, which is the normal operating temperature of the engine.

Connect a temporary engine mounted temperature gauge of suitable accuracy and start the engine. Once the engine reaches normal operating temperature, enter the programming mode and scroll to the "Engine Temperature Offset" calibration point.

Use the INCREMENT or DECREMENT push-buttons to adjust the correction factor number while observing the displayed temperature on the MEC 20. Adjust the correction factor number to obtain the identical temperature reading as measured with the external temperature gauge. With the correct temperature displayed, press the "enter" push-button to accept the correction factor number. Record the correction factor number on the MEC 20 programming sheet for future reference if required.

10.6.10. PRESSURE CALIBRATION PROCEDURE

Before the equipment is put into final operating service, the engine pressure analog circuit must be field calibrated to meet the performance accuracy as specified, to ensure correct operation. The engine pressure analog circuit must be calibrated with the engine pressure sender supplied with the controller and mounted on the engine.

WARNING!!!

Failure to field calibrate and validate the correct operation of the pressure analog circuit on the equipment may result in severe equipment failure or damage.

To calibrate the MEC 20 pressure sensor, perform the following procedure:

NOTE:

To accurately calibrate the MEC 20's pressure sensor, an external temporary engine mounted pressure gauge is required. The external pressure gauge should be connected as close as possible to the pressure sender for the MEC 20.

The calibration procedure is to be done only at a single point, which is the normal operating pressure of the engine.

Connect a temporary engine mounted pressure gauge of suitable accuracy and start the engine. Once the engine reaches normal operating pressure and temperature, enter the programming mode and scroll to the "Engine Pressure Offset" calibration point.

Use the INCREMENT or DECREMENT push-buttons to adjust the correction factor number while observing the displayed pressure on the MEC 20. Adjust the correction factor number to obtain the identical pressure reading as measured with the external pressure gauge.

With the correct pressure displayed, press the “enter” push-button to accept the correction factor number. Record the correction factor number on the MEC 20 programming sheet for future reference

Engine Pressure		Sender Resistance ¹
KPA	PSI	Ohms
1034	150	38
965	140	42
896	130	48
827	120	54
758	110	62
689	100	70
621	90	79
552	80	89
483	70	101
414	60	114
345	50	127
276	40	142
207	30	160
138	20	183
69	10	206

Engine Temperature		Sensor Resistance
F	C	Ohms
392	200	20
374	190	24
356	180	28
338	170	33
320	160	39
302	150	46
284	140	55
266	130	65
248	120	76
230	110	90
212	100	106
194	90	147
176	80	197
150	70	290
140	60	426
122	50	622
104	40	952
86	30	1486
68	20	2322
50	10	3644
32	0	6284

¹ Sender resistance data shown are for Oil Pressure Sender p/n-003654 (Thomson p/n), Manufacturer- Datcon, p/n 102227. Datcon Sender must be used with MEC software version 1.81 or greater (previous software versions cannot be used).

Figure 22

11. PROGRAMMING SHEETS

11.1. SUMMARY CONFIGURATION DATA SHEET

 MEC 20 MICROPROCESSOR ENGINE/GENERATOR CONTROLLER SUMMARY CONFIGURATION DATA SHEET			
WORK ORDER #:	REV:	REV DATE:	
INITIATED BY:	CUSTOMER:	DEFAULT PROGRAM:	
DATE:	PROJECT NAME:	TPS VER:	
NOTES:			
ENGINE/GEN SYSTEM INPUTS			
SYSTEM AC VOLTS:	PHASES:	FREQUENCY:	DC VOLTAGE:
DIGITAL DISPLAY FEATURES			
<input type="checkbox"/> AC VOLTAGE	<input type="checkbox"/> AC CURRENT	<input type="checkbox"/> BATTERY VOLTAGE	
<input type="checkbox"/> ENGINE TEMPERATURE	<input type="checkbox"/> KVA	<input type="checkbox"/> TACHOMETER	
<input type="checkbox"/> OIL PRESSURE	<input type="checkbox"/> FREQUENCY	<input type="checkbox"/> HOURMETER	
DIGITAL FAULT CIRCUITS (15)		ANALOG FAULT CIRCUITS	
FAULT NAME	INPUT NAME	FAULT NAME	INPUT NAME
Overcrank Shutdown	Internal	Overspeed Shutdown	Mag-Pickup
Switch Not in Auto Alarm	Internal	Loss of Speed Sig. Shtdn	Mag-Pickup
Emergency Stop	Internal/ext	Undervoltage Shutdown	AC Voltage
<input type="checkbox"/> Low Oil Press Shtdn (Std Default) or <input type="checkbox"/> Custom _____	Ext Dig Input #1	Overvoltage Shutdown	AC Voltage
<input type="checkbox"/> High Eng Temp Shtdn (Std Default) or <input type="checkbox"/> Custom _____	Ext Dig Input #2	Under Frequency Alarm	AC Freq
<input type="checkbox"/> Low Coolant Lvl Shtdn(CSA Std Default) or <input type="checkbox"/> Bat Chgr AC Fail (NFPA Std Default) or <input type="checkbox"/> Custom _____	Ext Dig Input #3	Over Frequency Alarm	AC Freq
<input type="checkbox"/> Low Fuel Level Alarm (Std Default) or <input type="checkbox"/> Custom _____	Ext Dig Input #4	Overcurrent Alarm	AC Current
	Ext Dig Input #5	Weak Battery Alarm	DC Volts
	Ext Dig Input #6	Low Battery Voltage Alarm	DC Volts
	Ext Dig Input #7	High Battery Voltage Alarm	DC Volts
	Ext Dig Input #8	Low Engine Temp. Alarm	Temp. Sender
	Ext Dig Input #9	High Engine Temp #1 Alm	Temp. Sender
	Ext Dig Inpt #10	High Engine Temp #2 Shdn	Temp. Sender
<input type="checkbox"/> Remote Emerg Stop (Std Default) or <input type="checkbox"/> Custom _____	Ext Dig Inpt #11	Low Oil Pressure #1 Alarm	Press. Sender
<input type="checkbox"/> Idle Control or <input type="checkbox"/> Custom _____	Ext Dig Inpt #12	Low Oil Pressure #2 Shutdown	Press. Sender
STANDARD OUTPUT CONTACTS			
	OUTPUT NAME	OUTPUT TYPE	
	Run (Fuel)	Form A	
	Crank	Form A	
	Common Fail	Form C	
PROGRAMMABLE CONTACTS			
OUTPUT NAME			OUTPUT TYPE
<input type="checkbox"/> ATS Test (Std Default) or Custom _____			Programmable #1 – Form C
<input type="checkbox"/> Common Alarm (Std Default) or Custom _____			Programmable #2 – Form C
<input type="checkbox"/> Common Shutdown (Std Default) or Custom _____			Programmable #3 – Form C
<input type="checkbox"/> Engine Running (Std Default) or Custom _____			Programmable #4 – Form C
<input type="checkbox"/> EPS Supplying Load/Engine Running (Std Default) or Custom _____			Programmable #5 – Form A/B (EAP 110/MEC 20 Exp –Group 1 Only)
<input type="checkbox"/> Disabled (Std Default) or Custom _____			Programmable #6 – Form A/B] (EAP 110/MEC 20 Exp –Group 2 Only)
OTHER OPTIONAL FEATURES			
<input type="checkbox"/> Remote Communication Port Enabled		<input type="checkbox"/> VFD Display	

11.2. MAIN CONFIGURATION

MAIN PROGRAMMING MENU		
NODE ADDRESS		REMOTE COM OPTION
XXX		1-255
SYSTEM VOLTAGE		LINE TO LINE VOLTAGE
XXXXX VAC		120-15000VAC
SYSTEM FREQUENCY		
50HZ/60HZ		TOGGLE BETWEEN 50/60 HZ
SYSTEM PHASES		
1 PHASE/3 PHASE		TOGGLE BETWEEN 1 & 3 PHASE
NEUTRAL CONNECTED		TOGGLE BETWEEN YES/NO
VOLTAGE SENSING		VOLTAGE SENSING PT RATIO
RATIO XXX		ENTER NUMBER 1-208 (1=DIRECT)
CURRENT SENSING		CURRENT SENSING CT RATIO
RATIO XXX		ENTER NUMBER 1-999 (1=DIRECT)
TEMPERATURE SCALE		
DEG C/DEG F		TOGGLE BETWEEN DEG C/DEG F
PRESSURE SCALE		
PSI/KPA		TOGGLE BETWEEN PSI/KPA
START DELAY		
XXX SECONDS		0-999 SECONDS
CRANK TIME		
XX SECONDS		0-99 SECONDS
REST TIME		
XX SECONDS		0-99 SECONDS
STARTER RE-ENGAGE		
DELAY XX SECONDS		0-99 SECONDS 0=DISABLED

MAIN PROGRAMMING MENU		
NUMBER OF CRANKS		
XX		0-99 TIMES 0=CONTINUOUS
BYPASS DELAY		
XX SECONDS		0-99 SECONDS
COOLDOWN DELAY		
XX SECONDS		0-9999 SECONDS
NOMINAL RPM		
XXXX RPM		0-4000RPM
FLYWHEEL TEETH		ENGINE SPEED SENSING VIA MAGNETIC PICK UP
XXX		0-999 TEETH
CRANK DISCONNECT		
XX PERCENT		0-100%
OVERSPEED		
XX PERCENT		100-150%
OVERSPEED TRANSIENT		
X.X SEC		0.0-9.9 SEC
RUN OUTPUT		
FAIL SAFE YES/NO		TOGGLE BETWEEN YES/NO
LOSS OF SPEED SIGNAL		
SHUTDOWN ALARM/SHUTDOWN		TOGGLE BETWEEN ALARM/SHUTDOWN
COMMON FAIL FOR		
NOT IN AUTO YES/NO		TOGGLE BETWEEN YES/NO
PROG OUTPUT #1		Common Fail (Factory default, unless otherwise specified)
PROG OUTPUT #2		
PROG OUTPUT #3		

MAIN PROGRAMMING MENU		
PROG OUTPUT #4		
PROG OUTPUT #5		
PROG OUTPUT #6		
WARMUP DELAY		0 – 99 SECONDS
NEUTRAL DELAY		0 – 99 SECONDS
RETURN DELAY		0 – 999 SECONDS
RESET RUN HOURS		ACCESS VIA MASTER PASSWORD ONLY
YES/NO		TOGGLE YES/NO,

11.3. ANALOG FAULT PROGRAMMING MENU

TYPICAL PROGRAM FACTORY DEFAULT SETTINGS

ANALOG FAULT PROGRAMMING MENU								
FAULT NAME	INPUT ANALOG TYPE	FAULT E=ENABLE D=DISABLE	SETPOINT LEVEL (PICK-UP)	SETPOINT LEVEL (DROP-OUT)	ACTION S=SHUTDOWN A=ALARM	ALARM LATCH Y=YES N=NO	BYPASS ON START Y=YES N=NO	TRANSIENT DELAY (SEC)
UNDER VOLTAGE	AC VOLTAGE	E*			S	Y	Y*	5.0
OVER VOLTAGE	AC VOLTAGE	E*			S	Y	N	2.0
UNDER FREQUENCY	AC FREQUENCY	E*			S	Y	Y*	5.0
OVER FREQUENCY	AC FREQUENCY	E*			A	Y	N	2.0
OVER CURRENT	AC CURRENT	E*	500	4990	A	Y	N	20.0
WEAK BATTERY	DC VOLTAGE	E*	18.0	N/A	A*	Y	N*	3.0
LOW BATTERY VOLTAGE	DC VOLTAGE	E*	25.6	N/A	A*	N	N*	120.0
HIGH BATTERY VOLTAGE	DC VOLTAGE	E*	30.4	N/A	A*	N	N*	10.0
LOW ENGINE TEMP	TEMP SENDER	E*	95°F	N/A	A*	Y	N*	5.0
HIGH ENG TEMP #1 ALARM	TEMP SENDER	E*	198°F	N/A	A	Y	Y	2.0
HIGH ENG TEMP #2 SHUTDOWN	TEMP SENDER	E*	206°F	N/A	S	Y	Y	2.0
LOW OIL PRESS#1 ALARM	PRESS SENDER	E*	30PSI	N/A	A	Y	Y*	2.0
LOW OIL PRESS#2 SHUTDOWN	PRESS SENDER	E*	20PSI	N/A	S	Y	Y*	2.0

* Indicates feature is non-programmable (i.e. is fixed) in software

11.4. **DIGITAL FAULT PROGRAMMING MENU**

TYPICAL PROGRAM FACTORY DEFAULT SETTINGS

DIGITAL FAULT PROGRAMMING MENU						
FAULT NAME	INPUT #	ACTION S=SHUTDOWN A=ALARM	ALARM LATCH Y=YES N=NO	POLARITY O=OPEN C=CLOSE	BYPASS ON START Y=YES N=NO	TRANSIENT DELAY (SEC)
LOW OIL PRESSURE	1	S	—	O	Y	0.5
HIGH ENG TEMP	2	S	—	O	Y	1.0
BATT CHGR INPUT FAIL	3	A	Y	C	N	30.0
LOW FUEL LEVEL	4	A	N	C	N	0.1
“blank”	5	A	N	C	N	0.0
“blank”	6	A	N	C	N	0.0
“blank”	7	A	N	C	N	0.0
“blank”	8	A	N	C	N	0.0
“blank”	9	A	N	C	N	0.0
“blank”	10	A	N	C	N	0.0
REMOTE EMERG STOP	11	S	N	C	N	0.1
IDLE	12	A	N	C	N	0.1

11.5. CALIBRATION MENU

CALIBRATION MENU					
VOLTS	A-B	ZERO	XXX	XXXVAC	
VOLTS	A-B	SPAN	XXX	XXXVAC	
VOLTS	B-C	ZERO	XXX	XXXVAC	
VOLTS	B-C	SPAN	XXX	XXXVAC	
VOLTS	C-A	ZERO	XXX	XXXVAC	
VOLTS	C-A	SPAN	XXX	XXXVAC	
VOLTS	A-N	ZERO	XXX	XXXVAC	
VOLTS	A-N	SPAN	XXX	XXXVAC	
VOLTS	B-N	ZERO	XXX	XXXVAC	
VOLTS	B-N	SPAN	XXX	XXXVAC	
VOLTS	C-N	ZERO	XXX	XXXVAC	
VOLTS	C-N	SPAN	XXX	XXXVAC	
CURRENT	A	ZERO	XXX	XXXVAC	
CURRENT	A	SPAN	XXX	XXXVAC	
CURRENT	B	ZERO	XXX	XXXVAC	
CURRENT	B	SPAN	XXX	XXXVAC	
CURRENT	C	ZERO	XXX	XXXVAC	
CURRENT	C	SPAN	XXX	XXXVAC	
BATTERY VOLTAGE		SPAN	XXX	XXXVAC	
ENGINE TEMPERATURE		XXX	XXX	C/F	
OIL PRESSURE		XXX	XXXX	PSI/KPA	

12. SPECIFICATIONS

- **Power supply:** 10 to 30Vdc, negative ground
- **Operating temperature:** -15°C to +50°C¹

¹Extended temperature ratings are available using the VFD display option. Extended ratings are: Operating -40°C to +70°C, Storage -50°C to +85°C

- **Environmental (Faceplate):** NEMA 12
- **Vibration:** 4g, 5-250Hz
- **Power consumption:** 5 watts (max.)
- **Storage temperature:** -20°C to +70°C¹
- **Humidity:** 5 to 95% non-condensing
- **Dimensions:** 10.75"W x 6.75"H x 2.0"D
- **AC Metering Accuracy:** ± 1.0%, @ 25°C Volts, Amps
± 2% @25°C KVA
- **Inputs:**
 - Engine Speed Sensing 100 - 10,000Hz, 3.0 - 20Vac, rms
 - AC Voltage 120 - 600Vac (nominal), 0.1VA, 3 phase, 50/60Hz
 - AC Current 0 - 5Aac (nominal), 1.5VA, 3 phase
 - Engine Parameters Dedicated Senders (supplied loose)
 - Digital Fault Contacts Open or close to DC Negative
- **Output contacts:**
 - Run, Crank 10A/240Vac, 8A/24Vdc resistive (3A inductive, 0.4pf), Form A
 - Programmable 10A/240Vac, 8A/24Vdc resistive (3A inductive, 0.4pf), Form A
- **Analog Oil Pressure Measurement:**
 - Range: 15 PSI – 150 PSI (maximum)
 - Pressure Accuracy Operating range 15 - 59 PSI = +-6 PSI
Operating range 60 - 75 PSI = +-2 PSI
Operating range 76-150 PSI = +-7 PSI
- **Analog Engine Temperature Measurement:**
 - Range: 0-200°C (maximum)
 - Temperature Accuracy Operating range 0 - 30°C = +-8°C
Operating range 30 -100°C = +-2°C
Operating range 100 -200°C = +-8°C

Specifications subject to change without notice.

13. CONNECTION DIAGRAM

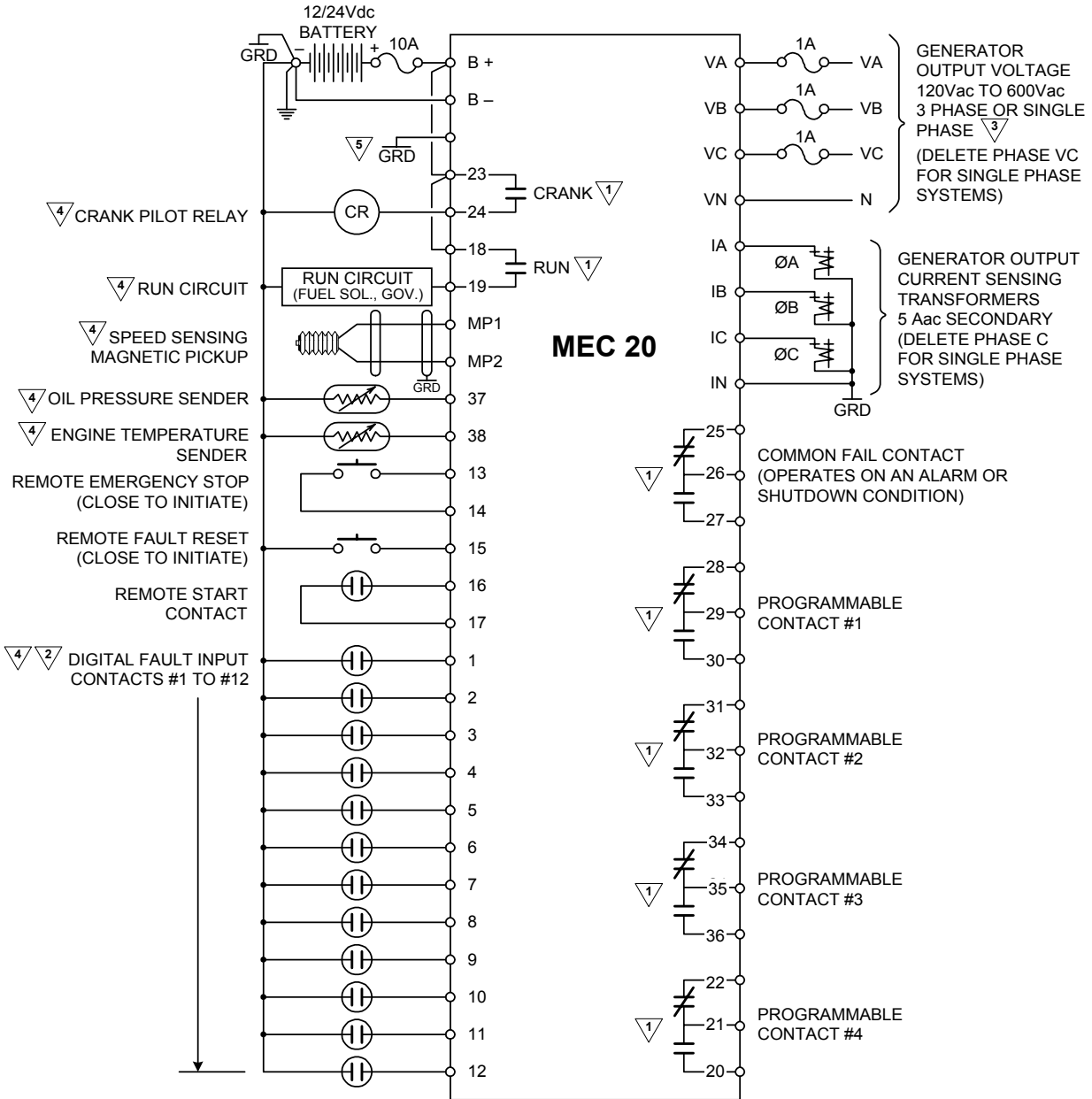

NOTES:

- 1 CONTACTS RATED MAXIMUM 10A/240Vac, 8A/24Vdc RESISTIVE
- 2 LOGIC IS SOFTWARE PROGRAMMABLE FOR OPEN OR CLOSE ON FAIL
- 3 GENERATOR SUPPLY MUST UTILIZE A SOLIDLY GROUNDED NEUTRAL SYSTEM – REFER TO INSTRUCTION MANUAL FOR ALTERNATE CONNECTIONS
- 4 ENGINE MOUNTED COMPONENTS
- 5 "GRD" CONNECTION TO BE MADE TO COMMON CHASSIS/ENCLOSURE GROUND BOND SYSTEM

G:\ENGINEER\PRODUCTS\MEC20_04.VSD REV 3 02/02/20

14. TROUBLE SHOOTING

A number of problems can cause the MEC 20 controller not to function properly. Refer to the following list of typical problems. Consult the factory for any detailed information or for any problems not listed.

CAUTION!!!

Before opening the enclosure to perform any service task, it is imperative to isolate the control system from any possible source of power. Failure to do so may result in serious personal injury or death due to electrical shock.

Service procedures must be undertaken by qualified personnel only!

SYMPTOM	CORRECTIVE ACTION
Controller does not power up even with correct DC power applied	<ul style="list-style-type: none"> - Check that there are no wiring errors/short circuits connected to the controller. Note: The MEC 20 contains an electronic fuse that triggers upon an overload condition and does <u>not</u> reset until the supply voltage is removed, and overload condition is corrected.
LCD Display is not operational	<ul style="list-style-type: none"> - Check that the controller's microprocessor is running by observing a red flashing "watchdog" LED on the rear of the PCB. - Check that there is sufficient DC supply voltage to input terminals B+ & B- (10-30VDC). - Verify that the LCD contrast potentiometer (R115) on rear of PCB is adjusted for good pixel resolution for the operating temperature of the unit.
Controller cannot be "Reset"	<ul style="list-style-type: none"> - Check that the controller is set to the OFF mode before trying to reset. - Check that the engine has come to a complete stop before trying to reset.

SYMPTOM (CONT'D)	CORRECTIVE ACTION (CONT'D)
No "RUN" output signal	<ul style="list-style-type: none"> - Check that all shutdown circuits are reset (red shutdown LED must be off). - Engine speed signal must be detected (speed signal green LED on) during cranking if the "run-output fail safe" feature is enabled. Verify correct magnetic pick-up signal at cranking (2.0VAC min.). - Check that the RUN output LED (on the rear of the PCB) is on. If yes, verify relay contact operation on terminals #18 & #19.
Overspeed shutdown occurs at normal speed	<ul style="list-style-type: none"> - Verify that the controller has been programmed with the correct values for the number of flywheel teeth, nominal RPM, and overspeed setpoint percentage.
Voltage or current metering is reading incorrectly	<ul style="list-style-type: none"> - Verify that the controller has been programmed with the correct values for the voltage sensing PT ratio and/or current sensing CT ratio. - Verify that the battery supply DC negative conductor is properly grounded to the engine block (i.e. to a common ground point). - Verify that the controller's analog input has been properly calibrated as per manual instructions. - Verify the voltage sensing wiring connection to the MEC 20 matches power distribution type. (Note: standard <i>direct</i> voltage connection requires that the generators neutral is solidly grounded.)
Engine temperature or oil pressure display is reading incorrectly	<ul style="list-style-type: none"> - Verify that the controller's analog input has been properly calibrated as per manual instructions. - Verify engine sensor wiring is correct. (Note: engine sensors must be factory supplied units only.) - Verify that the battery supply DC negative conductor is properly grounded to the engine block (i.e. to a common ground point).

SYMPTOM (CONT'D)	CORRECTIVE ACTION (CONT'D)
<p>Engine temperature or oil pressure displays 9999</p>	<ul style="list-style-type: none"> - Check the wiring from the MEC 20 terminal #37 & #38 to the engine mounted sender are correct (i.e. wiring is not open or shorted). - Verify the engine mounted senders have correct resistance reading for corresponding input temperature or pressure (refer to the Analog Temperature and Pressure Calibration table for values). - Verify calibration.
<p>Engine alarms on high engine temperature or low oil pressure when engine is operating within normal limits</p>	<ul style="list-style-type: none"> - Check the wiring from the MEC 20 terminals #37 & #38 to the engine mounted senders is correct (i.e. wiring is not open or shorted). - Verify the engine mounted senders have correct resistance reading for corresponding input temperature or pressure (refer to the Analog Temperature and Pressure Calibration table for values).
<p>Key presses on the lexan faceplate do not operate</p>	<ul style="list-style-type: none"> - Verify the interconnecting ribbon cable between the lexan faceplate and main printed circuit board is correctly connected.

15. NOTES