

Cat. No. Z183-E1-01

ZEN Programmable Relay

OPERATION MANUAL

OMRON

ZEN Programmable Relay

Operation Manual

Produced May 2003

Notice:

OMRON products are manufactured for use according to proper procedures by a qualified operator and only for the purposes described in this manual.

The following conventions are used to indicate and classify precautions in this manual. Always heed the information provided with them. Failure to heed precautions can result in injury to people or damage to property.

 **DANGER** Indicates an imminently hazardous situation which, if not avoided, will result in death or serious injury.

 **WARNING** Indicates a potentially hazardous situation which, if not avoided, could result in death or serious injury.

 **Caution** Indicates a potentially hazardous situation which, if not avoided, may result in minor or moderate injury, or property damage.

OMRON Product References

All OMRON products are capitalized in this manual. The word “Unit” is also capitalized when it refers to an OMRON product, regardless of whether or not it appears in the proper name of the product.

Visual Aids

The following headings appear in the left column of the manual to help you locate different types of information.

Note Indicates information of particular interest for efficient and convenient operation of the product.

1,2,3... 1. Indicates lists of one sort or another, such as procedures, checklists, etc.

Precaution Indicates precautionary information that should be heeded in using the ZEN.



Indicates that the display (the word “LANGUAGE” in this case) is flashing. In this manual, this state is described by saying that the “flashing cursor” is at the word “LANGUAGE”. In this state it is possible to change settings and the position of the cursor.

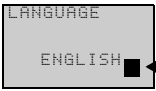

Indicates that the display (the letter “H” in this case) is flashing in reverse video. In this manual, this state is described by saying that the “highlighted cursor” is at the word “H”. In this state it is not possible to change settings but the cursor can be changed to the flashing cursor by pressing the **OK** button.



Indicate the buttons that needs to be pressed in operating procedures. Press each button once.



Indicate buttons that needs to be pressed in operating procedures. Press one of the buttons once or more.

© OMRON Electronics LLC 2003

All rights reserved. No part of this publication may be reproduced, stored in a retrieval system, or transmitted, in any form, or by any means, mechanical, electronic, photocopying, recording, or otherwise, without the prior written permission of OMRON.

No patent liability is assumed with respect to the use of the information contained herein. Moreover, because OMRON is constantly striving to improve its high-quality products, the information contained in this manual is subject to change without notice. Every precaution has been taken in the preparation of this manual. Nevertheless, OMRON assumes no responsibility for errors or omissions. Neither is any liability assumed for damages resulting from the use of the information contained in this publication.

TABLE OF CONTENTS

PRECAUTIONSxi
1 Safety Precautions	xii
2 Application Precautions	xiii
3 Operating Environment Precautions	xvi
4 Conformance to EC Directives	xvi
5 Operating Mode at Startup.....	xix
6 Memory Backup.....	xx
7 Version Upgrades.....	xxi

SECTION 1

Outline	1
1-1 Outline	2
1-2 Features and Part Names	8
1-3 Display Screen and Basic Operations	16
1-4 Memory Areas	27
1-5 Allocating I/O Bit Numbers.....	29
1-6 Preparations for Operation.....	30

SECTION 2

Installation and Wiring31
2-1 Mounting	32
2-2 Wiring	33

SECTION 3

Programming and Operating Methods49
3-1 Selecting Display Language	50
3-2 Setting the Date and Time	51
3-3 Creating Ladder Programs.....	52
3-4 Confirming Ladder Program Operation.....	62
3-5 Correcting Ladder Programs	64
3-6 Using Timers (T) and Holding Timers (#).....	67
3-7 Using Counters (C)	70
3-8 Using Weekly Timers (@).....	72
3-9 Using Calendar Timers (*).....	74
3-10 Analog Inputs (Analog Comparators (A)).....	75
3-11 Comparing Timer/Counter Present Values Using Comparators (P)	79
3-12 Displaying Messages (Display Bits (D))	82
3-13 Using Button Switches (B)	85

TABLE OF CONTENTS

SECTION 4

Special Functions	87
4-1 Protecting Programs.....	88
4-2 Stabilizing Input Operations.....	90
4-3 Changing Backlight Automatic Cutout Time.....	92
4-4 Adjusting LCD Screen Contrast.....	93
4-5 Setting Summertime.....	93
4-6 Reading System Information.....	94

SECTION 5

Optional Products	95
5-1 Mounting Battery Units.....	96
5-2 Using Memory Cassettes.....	97
5-3 Connecting the ZEN Support Software.....	99

SECTION 6

Troubleshooting	101
6-1 Troubleshooting.....	102
6-2 Error Messages.....	102
6-3 Deleting Error Messages.....	104

Appendices

A Product Configurations.....	105
B Specifications.....	109
C Ladder Program Execution.....	121
D Application Examples.....	123
E Allocations and Setting Sheets.....	137

Index	145
--------------------	------------

Revision History	149
-------------------------------	------------

PRECAUTIONS

This section provides general precautions for using the ZEN Programmable Relay.

The information contained in this section is important for the safe and reliable application of the ZEN. You must read this section and understand the information contained before attempting to set up or operate the ZEN.

1	Safety Precautions	xi
2	Application Precautions	xii
2-1	Circuit Design and Ladder Programming	xii
2-2	Installation	xiii
2-3	Wiring and Connections.	xiii
2-4	I/O Connections and Startup Precautions	xiv
2-5	Handling.	xiv
2-6	Maintenance.	xv
2-7	Transportation and Storage	xv
3	Operating Environment Precautions	xv
4	Conformance to EC Directives	xvi
4-1	Applicable Directives.	xvi
4-2	Concepts.	xvi
4-3	Conformance to EC Directives	xvii
4-4	Relay Output Noise Reduction Methods	xvii
5	Operating Mode at Startup.	xix
6	Memory Backup.	xix
7	Version Upgrades.	xx
7-1	Application Precautions for Differences between Versions.	xxi
7-2	CPU Units Covered in this Manual	xxii

1 Safety Precautions

 **WARNING** Never attempt to disassemble any Units while power is being supplied. Doing so may result in serious electrical shock or electrocution.

 **WARNING** Never touch the I/O terminals, computer connector, Expansion Unit connector, or Battery Unit connector while power is being supplied. Doing so may result in serious electrical shock or electrocution.

 **WARNING** Provide safety measures in external circuits (i.e., not in the ZEN), including the following items, to ensure safety in the system if an abnormality occurs due to malfunction of the ZEN or another external factor affecting the ZEN operation. Not doing so may result in serious accidents.

- Emergency stop circuits, interlock circuits, limit circuits, and similar safety measures must be provided in external control circuits.
- The ZEN will turn OFF all outputs when its self-diagnosis function detects any error. As a countermeasure for such errors, external safety measures must be provided to ensure safety in the system.
- The ZEN outputs may remain ON or OFF due to deposition or burning of the output relays or destruction of the output transistors. As a countermeasure for such problems, external safety measures must be provided to ensure safety in the system.
- Provide double safety mechanisms to handle incorrect signals that can be generated by broken signal lines or momentary power interruptions.

 **WARNING** Do not short the battery terminals or charge, disassemble, heat, or incinerate the battery. Do not subject the battery to strong shocks. Doing any of these may result in leakage, rupture, heat generation, or ignition of the battery. Dispose of any battery that has been dropped on the floor or otherwise subjected to excessive shock. Batteries that have been subjected to shock may leak if they are used.

 **Caution** Tighten the AC power supply terminal block screws to the torque specified in the manual. Loose screws can result in fire or faulty operation.

2 Application Precautions

Observe the following precautions when using the ZEN.

2-1 Circuit Design and Ladder Programming

- Provide external interlock circuits, limit circuits, and other safety circuits in addition to any provided within the ZEN to ensure safety.

- The output relays or the output transistors may remain ON due to faults in internal circuits such as output relays or output transistors. As a countermeasure for such problems, external safety measures must be provided to ensure safety in the system.
- Always turn ON power to the ZEN before turning ON power to the I/O circuits. If the ZEN power supply is turned ON after the I/O power supply, temporary errors may result in operation.
- The life of the output relays is largely affected by the switching conditions. Confirm the operation of the system under actual operating conditions and set the switching frequency to ensure that adequate performance will be provided. Insulation faults and burning in the ZEN may result if relays are used after their performance has deteriorated.

2-2 Installation

- Install the ZEN according to instructions in the operation manual. Improper installation may cause faulty operation.
- Do not install the ZEN in locations subject to excessive noise. Malfunction may occur.
- Do not allow the ZEN to fall during installation.
- Be sure that all the mounting screws on the ZEN and Expansion I/O Unit are tightened to the torque specified in the manual. Incorrect tightening torque may result in malfunction.
- Use with the cover of the computer connector mounted. Using without the cover may result in malfunction due to dust or other foreign matter.
- Be sure that the DIN rail mounting levers, Expansion I/O Units, Memory Cassettes, Battery Units, cable connectors, and other items with locking devices are properly locked into place. Improper locking may result in malfunction.

2-3 Wiring and Connections

- Use the wires specified in this manual when wiring. Use straight crimp terminals when connecting loose wires.
- Provide circuit breakers and other safety measures to provide protection against shorts in external wiring.
- Use separate wiring ducts for signal wires from those used for power supply and high-voltage lines.
- Always check polarity when connecting cables.
- Leave the label attached to the Unit when wiring. Removing the label may result in malfunction if foreign matter enters the Unit.

- Remove the label after the completion of wiring to ensure proper heat dissipation. Leaving the label attached may result in malfunction.
- Tighten the terminal block screws to the torque specified in the manual.
- Wire the ZEN according to instructions in the operation manual. Improper installation may cause faulty operation.

2-4 I/O Connections and Startup Precautions

- Use the Units only with the power supplies and voltages specified in the operation manual. Other power supplies and voltages may damage the Units.
- Take measures to stabilize the power supply to conform to the rated supply if it is not stable.
- Do not apply voltages exceeding the rated input voltage to input circuits. The input circuits may be destroyed.
- Do not apply voltages exceeding the maximum switching capacity to output circuits. The output circuits may be destroyed.
- Double-check all wiring before turning ON the power supply. Incorrect wiring may result in burning.
- Check the user program for proper execution before actually running it on the Unit. Not checking the program may result in an unexpected operation.

2-5 Handling

- Use, store, and transport the ZEN under the limits given for general specifications in this manual.
- Do not attempt to disassemble, repair, or modify any Units. Any attempt to do so may result in malfunction, fire, or electric shock.
- Always turn OFF the power supply to the ZEN before attempting any of the following.
 - Assembling the ZEN.
 - Attaching or removing the Expansion I/O Unit.
 - Connecting or disconnecting any cables or wiring.
 - Attaching or removing the Memory Cassette.
 - Attaching or removing the Battery Unit.
- Confirm that no adverse effect will occur in the system before attempting any of the following. Not doing so may result in an unexpected operation.
 - Changing the operating mode.
 - Using the button switches.

- Changing bit status or parameter settings.
- Before touching a Unit, be sure to first touch a grounded metallic object in order to discharge any static build-up.
- Do not pull on the cables or bend the cables beyond their natural limit. Doing either of these may break the cables.
- Do not place objects on top of the cables or other wiring lines. Doing so may break the cables.
- Do not short the battery terminals or charge, disassemble, heat, or incinerate the battery. Do not subject the battery to strong shocks. Doing any of these may result in leakage, rupture, heat generation, or ignition of the battery. Dispose of any battery that has been dropped on the floor or otherwise subjected to excessive shock. Batteries that have been subjected to shock may leak if they are used.
- Abide by all local ordinances and regulations when disposing of the ZEN.

2-6 Maintenance

- When replacing parts, be sure to confirm that the rating of a new part is correct.
- When replacing a Unit, transfer to the new Unit and confirm all settings for clock data, internal holding bits, holding timers, and counter before starting operation again.

2-7 Transportation and Storage

- Use special packaging boxes when transporting the ZEN and do not subject it to excessive shock or vibration or drop it during shipment.
- Store the ZEN in the following temperature and humidity ranges without condensation or icing.

Model	Ambient temperature	Humidity
LCD	-20 to 75°C	10% to 90%
LED	-40 to 75°C	

3 Operating Environment Precautions

Do not operate the control system in the following places.

- Where the ZEN is exposed to direct sunlight.
- Where the ambient temperature or humidity is beyond the specified ranges.

- Where the ZEN may be affected by condensation due to radical temperature changes.
- Where there is any corrosive or inflammable gas.
- Where there is excessive dust, saline air, or metal powder.
- Where the ZEN is affected by vibration or shock.
- Where any water, oil or chemical may splash on the ZEN.
- Any other place with conditions beyond those specified in the general specifications.

Take appropriate and sufficient countermeasures when installing systems in the following locations:

- Locations subject to static electricity or other forms of noise.
- Locations subject to strong electromagnetic fields.
- Locations subject to possible exposure to radioactivity.
- Locations close to power supplies.

4 Conformance to EC Directives

4-1 Applicable Directives

- EMC Directives
- Low Voltage Directive

4-2 Concepts

EMC Directives

OMRON devices that comply with EC Directives also conform to the related EMC standards so that they can be more easily built into other devices or the overall machine. The actual products have been checked for conformity to EMC standards (see the following note). Whether the products conform to the standards in the system used by the customer, however, must be checked by the customer.

EMC-related performance of the OMRON devices that comply with EC Directives will vary depending on the configuration, wiring, and other conditions of the equipment or control panel on which the OMRON devices are installed. The customer must, therefore, perform the final check to confirm that devices and the overall machine conform to EMC standards.

Note Applicable EMC (Electromagnetic Compatibility) standards are as follows:

EMS (Electromagnetic Susceptibility): EN61000-6-2
EMI (Electromagnetic Interference): EN50081-2
(Radiated emission: 10-m regulations)

Low Voltage Directive

Always ensure that devices operating at voltages of 50 to 1,000 VAC and 75 to 1,500 VDC meet the required safety standards for the ZEN (EN61131-2).

4-3 Conformance to EC Directives

The ZEN complies with EC Directives. To ensure that the machine or device in which the ZEN is used complies with EC Directives, the ZEN must be installed as follows:

- 1,2,3...**
1. The ZEN must be installed within a control panel.
 2. You must use reinforced insulation or double insulation for the DC power supplies used for the communications power supply and I/O power supplies.
 3. ZEN models complying with EC Directives also conform to the Common Emission Standard (EN50081-2). Radiated emission characteristics (10-m regulations) may vary depending on the configuration of the control panel used, other devices connected to the control panel, wiring, and other conditions.

You must therefore confirm that the overall machine or equipment complies with EC Directives.

4-4 Relay Output Noise Reduction Methods

The ZEN conforms to the Common Emission Standards (EN50081-2) of the EMC Directives. However, noise generated by relay output switching may not satisfy these Standards. In such a case, a noise filter must be connected to the load side or other appropriate countermeasures must be provided external to the ZEN.

Countermeasures taken to satisfy the standards vary depending on the devices on the load side, wiring, configuration of machines, etc. Following are examples of countermeasures for reducing the generated noise.

Countermeasures

(Refer to EN50081-2 for more details.)

Countermeasures are not required if the frequency of load switching for the whole system with the ZEN included is less than 5 times per minute.

Countermeasures are required if the frequency of load switching for the whole system with the ZEN included is more than 5 times per minute.

Countermeasure Examples

When switching an inductive load, connect a surge protector, diodes, etc., in parallel with the load or contact as shown below.

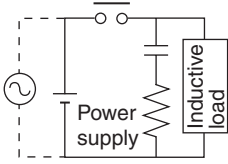
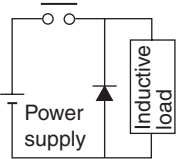
Circuit	Current		Characteristic	Required element
	AC	DC		
<p>CR method</p> 	Yes	Yes	<p>If the load is a relay or solenoid, there is a time lag between the moment the circuit is opened and the moment the load is reset.</p> <p>If the supply voltage is 24 or 48 V, insert the surge protector in parallel with the load. If the supply voltage is 100 to 200 V, insert the surge protector between the contacts.</p>	<p>The capacitance of the capacitor must be 1 to 0.5 μF per contact current of 1 A and resistance of the resistor must be 0.5 to 1 Ω per contact voltage of 1 V. These values, however, vary with the load and the characteristics of the relay. Decide these values from experiments, and take into consideration that the capacitance suppresses spark discharge when the contacts are separated and the resistance limits the current that flows into the load when the circuit is closed again.</p> <p>The dielectric strength of the capacitor must be 200 to 300 V. If the circuit is an AC circuit, use a capacitor with no polarity.</p>
<p>Diode method</p> 	No	Yes	<p>The diode connected in parallel with the load changes energy accumulated by the coil into a current, which then flows into the coil so that the current will be converted into Joule heat by the resistance of the inductive load.</p> <p>This time lag, between the moment the circuit is opened and the moment the load is reset, caused by this method is longer than that caused by the CR method.</p>	<p>The reversed dielectric strength value of the diode must be at least 10 times as large as the circuit voltage value. The forward current of the diode must be the same as or larger than the load current.</p> <p>The reversed dielectric strength value of the diode may be two to three times larger than the supply voltage if the surge protector is applied to electronic circuits with low circuit voltages.</p>

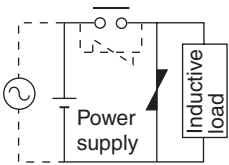
Circuit	Current		Characteristic	Required element
	AC	DC		
<p>Varistor method</p> 	Yes	Yes	<p>The varistor method prevents the imposition of high voltage between the contacts by using the constant voltage characteristic of the varistor. There is time lag between the moment the circuit is opened and the moment the load is reset.</p> <p>If the supply voltage is 24 or 48 V, insert the varistor in parallel with the load. If the supply voltage is 100 to 200 V, insert the varistor between the contacts.</p>	---

5 Operating Mode at Startup

The operating mode at startup depends on the model and the presence of a user program as shown in the following table.

User program	In CPU	No	Yes	No	Yes
	In Memory Cassette	No	No	Yes	Yes
LCD model (with LCD and operation buttons)	STOP mode	STOP mode	RUN mode with program in CPU	RUN mode with program in Memory Cassette	RUN mode with program in CPU
LED model (with LED and no operation buttons)	STOP mode	STOP mode	RUN mode with program in CPU	RUN mode with program in Memory Cassette	RUN mode with program in CPU

6 Memory Backup

The ladder program and settings are stored in EEPROM and thus will not be lost even if the power supply is turned OFF for an extended period of time (e.g., 2 days at 25°C). The status of the following data, however, is backed up by an internal capacitor, and may be lost if power is turned OFF for an extended period of time: ON/OFF status of holding bits (H), holding timers (#), and counters (C) and the prevent value areas. For models equipped with a clock/calendar, the time and date may be reset. Always reconfirm system operation before restarting operation after the power has been turned OFF for an extended period of time. We recommend that a Battery Unit be (optional) connected in any system in which power may be interrupted for an extended period of time.

7 Version Upgrades

The following table shows the relationship between the versions and functionality of the ZEN CPU Unit and ZEN Support Software

Date of upgrade	CPU Unit		Support Software
	System software version	Main changes	
January 2002	Ver. 1.10	<p>The following functions were added to the CPU Units with LCD displays.</p> <ul style="list-style-type: none"> • A Clear Display function • A Day/Month display object (DAT1) 	<p>The following functions were added to version 2.00 (ZEN-SOFT01-V2).</p> <ul style="list-style-type: none"> • Support for changes to display function • Simulation function • Improvements to functions, operating procedures, and displays
May 2003	Ver. 2.00	<ul style="list-style-type: none"> • The number of timers, counters, weekly timers, calendar timers, and display areas was increased from 8 to 16 each and the number of holding timers was increased from 4 to 8. (See note 2.) • A new CPU Unit with 20 I/O points was added. (See note 2.) • The input circuits of CPU Units with DC power supply were made compatible with both PNP and NPN. • A password input was added to the memory all clear function for CPU Units with LCDs. <p>Note The model numbers of CPU Units with 10 or 20 I/O points end in “-V1.”</p>	<p>The following functions were added to version 3.00 (ZEN-SOFT01-V3).</p> <ul style="list-style-type: none"> • Support for V1 CPU Units with 20 I/O points • Support for V1 CPU Units with 10 I/O points

- Note**
1. The number of the system software version in the CPU Unit is not related to the model number. The system software version of CPU Units with LCDs can be read by selecting **SYSTEM INFO** from the **OTHER** Menu. “V02.00” will be displayed as the system software version for V1 CPU Units.

2. Memory Area Comparison between V1 and Pre-V1 CPU Units

Area	V1 CPU Units		Pre-V1 CPU Units
	ZEN-10C□□□□-□-V1	ZEN-20C□□□□-□-V1	ZEN-10C□□□□-□
CPU Unit input bits	I0 to I5 (6 bits)	I0 to Ib (12 bits)	I0 to I5 (6 bits)
CPU Unit output bits	Q0 to Q3 (4 bits)	Q0 to Q7 (8 bits)	Q0 to Q3 (4 bits)
Timers	T0 to Tf (16 bits)		T0 to T7 (8 bits)
Holding timers	#0 to #7 (8 bits)		#0 to #3 (4 bits)
Counters	C0 to Cf (16 bits)		C0 to C7 (8 bits)
Weekly timers	@0 to @f (16 bits)		@0 to @f(8 bits)
Calendar timers	*0 to *f (16 bits)		*0 to *7 (8 bits)
Displays	D0 to Df (16 bits)		D0 to D7 (8 bits)
Work bits	M0 to Mf (16 bits)		
Holding bits	H0 to Hf (16 bits)		
Expansion I/O Unit input bits	X0 to Xb (12 bits)		
Expansion I/O Unit output bits	Y0 to Yb (12 bits)		
Analog comparators	A0 to A3 (4 bits)		
Comparators	P0 to Pf (16 bits)		

7-1 Application Precautions for Differences between Versions

Memory Cassette Compatibility

Be aware of the following restrictions when using a Memory Cassette containing a program that was stored from a CPU Unit with a different version of system software.

Version of CPU Unit used to write the Memory Cassette		Version of CPU Unit used to read the Memory Cassette			
		Ver. 1.00	Ver. 1.10	Ver. 2.20 (V1 CPU Units)	
				10 I/O points	20 I/O points
Ver. 1.00		OK	OK	OK	OK
Ver. 1.10		Restrictions (See note 1.)	OK	OK	OK
Ver. 2.00 (V1 CPU Units)	10 I/O points	Restrictions (See note 1.)	Restrictions (See note 2.)	OK	OK
	20 I/O points	Restrictions (See notes 1, 2, and 3.)	Restrictions (See notes 2 and 3.)	Restrictions (See note 3.)	OK

Note 1. The new display functions (display clear: -CD□ and day/month display: DAT1) cannot be used and will be ignored.

2. Only the memory area ranges supported by the pre-V1 CPU Units can be used for Timers, Holding Timers, Counters, Weekly Timers, Calendar Timers, and Displays (i.e., only half of each).
3. Only 6 inputs and 4 outputs can be used in the CPU Unit I/O bits. Any others will be ignored.

Compatibility of Programs Depending on Support Software Version

CPU Unit system software		Support Software		
		Ver. 1.00 ZEN-SOFT01	Ver. 2.00 ZEN-SOFT01-V2	Ver. 3.00 ZEN-SOFT01-V3
Ver. 1.00		OK	OK	Restrictions (See notes 1 and 2.)
Ver. 1.10		Restrictions (See note 1.)	OK	Restrictions (See note 2.)
Ver. 2.00 (V1 CPU Units)	10 I/O points	Restrictions (See notes 1 and 2.)	Restrictions (See note 2.)	OK
	20 I/O points	Not applicable.	Not applicable.	OK

- Note**
1. The new display functions (display clear: -CD□ and day/month display: DAT1) cannot be used and will be ignored.
 2. Only the memory area ranges supported by the pre-V1 CPU Units can be used for Timers, Holding Timers, Counters, Weekly Timers, Calendar Timers, and Displays (i.e., only half of each).

7-2 CPU Units Covered in this Manual

The material in this manual is based on the memory areas of the V1 CPU Units. If you are using a pre-V1 CPU Unit, the sizes of some of the memory areas will be different. Refer to page xxi for details.

Also, the I/O circuits and I/O terminal arrangements for CPU Units for DC power supply different between V1 and pre-V1 CPU Units, as described in the following table. Refer to page 38 for details

CPU Unit	I/O circuits
V1 CPU Units	With CPU Units for DC power supply, the common is separated from the power supply circuit in the I/O circuits, and a COM (common) terminal is provided for input terminals. This enables connecting devices with sourcing outputs (+ common) in addition to connecting devices with sinking outputs (- common).
Pre-V1 CPU Units	The negative size of the power supply for input circuits is connected internally to the negative side of the DC power supply. The input circuits can thus be used only with a - common.

Certain Terms and Conditions of Sale

- Offer; Acceptance.** These terms and conditions (these "Terms") are deemed part of all catalogs, manuals or other documents, whether electronic or in writing, relating to the sale of goods or services (collectively, the "Goods") by Omron Electronics LLC and its subsidiary companies ("Seller"). Seller hereby objects to any terms or conditions proposed in Buyer's purchase order or other documents which are inconsistent with, or in addition to, these Terms. Please contact your Omron representative to confirm any additional terms for sales from your Omron company.
- Prices.** All prices stated are current, subject to change without notice by Seller. Buyer agrees to pay the price in effect at time of shipment.
- Discounts.** Cash discounts, if any, will apply only on the net amount of invoices sent to Buyer after deducting transportation charges, taxes and duties, and will be allowed only if (i) the invoice is paid according to Seller's payment terms and (ii) Buyer has no past due amounts owing to Seller.
- Orders.** Seller will accept no order less than \$200 net billing.
- Governmental Approvals.** Buyer shall be responsible for, and shall bear all costs involved in, obtaining any government approvals required for the importation or sale of the Goods.
- Taxes.** All taxes, duties and other governmental charges (other than general real property and income taxes), including any interest or penalties thereon, imposed directly or indirectly on Seller or required to be collected directly or indirectly by Seller for the manufacture, production, sale, delivery, importation, consumption or use of the Goods sold hereunder (including customs duties and sales, excise, use, turnover and license taxes) shall be charged to and remitted by Buyer to Seller.
- Financial.** If the financial position of Buyer at any time becomes unsatisfactory to Seller, Seller reserves the right to stop shipments or require satisfactory security or payment in advance. If Buyer fails to make payment or otherwise comply with these Terms or any related agreement, Seller may (without liability and in addition to other remedies) cancel any unshipped portion of Goods sold hereunder and stop any Goods in transit until Buyer pays all amounts, including amounts payable hereunder, whether or not then due, which are owing to it by Buyer. Buyer shall in any event remain liable for all unpaid accounts.
- Cancellation; Etc.** Orders are not subject to rescheduling or cancellation unless Buyer indemnifies Seller fully against all costs or expenses arising in connection therewith.
- Force Majeure.** Seller shall not be liable for any delay or failure in delivery resulting from causes beyond its control, including earthquakes, fires, floods, strikes or other labor disputes, shortage of labor or materials, accidents to machinery, acts of sabotage, riots, delay in or lack of transportation or the requirements of any government authority.
- Shipping; Delivery.** Unless otherwise expressly agreed in writing by Seller:
 - Shipments shall be by a carrier selected by Seller;
 - Such carrier shall act as the agent of Buyer and delivery to such carrier shall constitute delivery to Buyer;
 - All sales and shipments of Goods shall be FOB shipping point (unless otherwise stated in writing by Seller), at which point title to and all risk of loss of the Goods shall pass from Seller to Buyer, provided that Seller shall retain a security interest in the Goods until the full purchase price is paid by Buyer;
 - Delivery and shipping dates are estimates only.
 - Seller will package Goods as it deems proper for protection against normal handling and extra charges apply to special conditions.
- Claims.** Any claim by Buyer against Seller for shortage or damage to the Goods occurring before delivery to the carrier must be presented in writing to Seller within 30 days of receipt of shipment and include the original transportation bill signed by the carrier noting that the carrier received the Goods from Seller in the condition claimed.
- Warranties.** (a) **Exclusive Warranty.** Seller's exclusive warranty is that the Goods will be free from defects in materials and workmanship for a period of twelve months from the date of sale by Seller (or such other period expressed in writing by Seller). Seller disclaims all other warranties, express or implied. (b) **Limitations.** SELLER MAKES NO WARRANTY OR REPRESENTATION, EXPRESS OR IMPLIED, ABOUT NON-INFRINGEMENT, MERCHANTABILITY OR FITNESS FOR A PARTICULAR PURPOSE OF THE GOODS. BUYER ACKNOWLEDGES THAT IT ALONE HAS DETERMINED THAT THE GOODS WILL SUITABLY MEET THE REQUIREMENTS OF THEIR INTENDED USE. Seller further disclaims all warranties and responsibility of any type for claims or expenses based on infringement by the Goods or otherwise of any intellectual property right. (c) **Buyer Remedy.** Seller's sole obligation hereunder shall be to replace (in the form originally shipped with Buyer responsible for labor charges for removal or replacement thereof) the non-complying Good or, at Seller's election, to repay or credit Buyer an amount equal to the purchase price of the Good; provided that in no event shall Seller be responsible for warranty, repair, indemnity or any other claims or expenses regarding the Goods unless Seller's analysis confirms that the Goods were properly handled, stored, installed and maintained and not subject to contamination, abuse, misuse or inappropriate modification. Return of any goods by Buyer must be approved in writing by Seller before shipment. Seller shall not be liable for the suitability or unsuitability or the results from the use of Goods in combination with any electrical or electronic components, circuits, system assemblies or any other materials or substances or environments. Any advice, recommendations or information given orally or in writing, are not to be construed as an amendment or addition to the above warranty.
- Damage Limits; Etc.** SELLER SHALL NOT BE LIABLE FOR SPECIAL, INDIRECT OR CONSEQUENTIAL DAMAGES, LOSS OF PROFITS OR PRODUCTION OR COMMERCIAL LOSS IN ANY WAY CONNECTED WITH THE GOODS, WHETHER SUCH CLAIM IS BASED IN CONTRACT, WARRANTY, NEGLIGENCE OR STRICT LIABILITY. Further, in no event shall liability of Seller exceed the individual price of the Good on which liability is asserted.
- Indemnities.** Buyer shall indemnify and hold harmless Seller, its affiliates and its employees from and against all liabilities, losses, claims, costs and expenses (including attorney's fees and expenses) related to any claim, investigation, litigation or proceeding (whether or not Seller is a party) which arises or is alleged to arise from Buyer's acts or omissions under these Terms or in any way with respect to the Goods. Without limiting the foregoing, Buyer (at its own expense) shall indemnify and hold harmless Seller and defend or settle any action brought against Seller to the extent that it is based on a claim that any Good made to Buyer specifications infringed intellectual property rights of another party.
- Property; Confidentiality.** The intellectual property embodied in the Goods is the exclusive property of Seller and its affiliates and Buyer shall not attempt to duplicate it in any way without the written permission of Seller. Notwithstanding any charges to Buyer for engineering or tooling, all engineering and tooling shall remain the exclusive property of Seller. All information and materials supplied by Seller to Buyer relating to the Goods are confidential and proprietary, and Buyer shall limit distribution thereof to its trusted employees and strictly prevent disclosure to any third party.
- Miscellaneous.** (a) **Waiver.** No failure or delay by Seller in exercising any right and no course of dealing between Buyer and Seller shall operate as a waiver of rights by Seller. (b) **Assignment.** Buyer may not assign its rights hereunder without Seller's written consent. (c) **Amendment.** These Terms constitute the entire agreement between Buyer and Seller relating to the Goods, and no provision may be changed or waived unless in writing signed by the parties. (d) **Severability.** If any provision hereof is rendered ineffective or invalid, such provision shall not invalidate any other provision. (e) **Setoff.** Buyer shall have no right to set off any amounts against the amount owing in respect of this invoice. (f) As used herein, "including" means "including without limitation".

Certain Precautions on Specifications and Use

- Suitability of Use.** Seller shall not be responsible for conformity with any standards, codes or regulations which apply to the combination of the Good in the Buyer's application or use of the Good. At Buyer's request, Seller will provide applicable third party certification documents identifying ratings and limitations of use which apply to the Good. This information by itself is not sufficient for a complete determination of the suitability of the Good in combination with the end product, machine, system, or other application or use. The following are some examples of applications for which particular attention must be given. This is not intended to be an exhaustive list of all possible uses of this Good, nor is it intended to imply that the uses listed may be suitable for this Good:
 - Outdoor use, uses involving potential chemical contamination or electrical interference, or conditions or uses not described in this document.
 - Energy control systems, combustion systems, railroad systems, aviation systems, medical equipment, amusement machines, vehicles, safety equipment, and installations subject to separate industry or government regulations.
 - Systems, machines and equipment that could present a risk to life or property. Please know and observe all prohibitions of use applicable to this Good.NEVER USE THE PRODUCT FOR AN APPLICATION INVOLVING SERIOUS RISK TO LIFE OR PROPERTY WITHOUT ENSURING THAT THE SYSTEM AS A WHOLE HAS BEEN DESIGNED TO ADDRESS THE RISKS, AND THAT THE SELLER'S PRODUCT IS PROPERLY RATED AND INSTALLED FOR THE INTENDED USE WITHIN THE OVERALL EQUIPMENT OR SYSTEM.
- Programmable Products.** Seller shall not be responsible for the user's programming of a programmable Good, or any consequence thereof.
- Performance Data.** Performance data given in this catalog is provided as a guide for the user in determining suitability and does not constitute a warranty. It may represent the result of Seller's test conditions, and the user must correlate it to actual application requirements. Actual performance is subject to the Seller's Warranty and Limitations of Liability.
- Change in Specifications.** Product specifications and accessories may be changed at any time based on improvements and other reasons. It is our practice to change part numbers when published ratings or features are changed, or when significant construction changes are made. However, some specifications of the Good may be changed without any notice. When in doubt, special part numbers may be assigned to fix or establish key specifications for your application. Please consult with your Seller's representative at any time to confirm actual specifications of purchased Good.
- Errors and Omissions.** The information in this catalog has been carefully checked and is believed to be accurate; however, no responsibility is assumed for clerical, typographical or proofreading errors, or omissions.

SECTION 1

Outline

This section gives an outline of the ZEN, including example applications, the system configurations and basic operations.

1-1	Outline	2
1-2	Features and Part Names	8
1-2-1	Features and System Configuration	8
1-2-2	Part Names	10
1-3	Display Screen and Basic Operations	16
1-3-1	Screens	18
1-3-2	Basic Operation	22
1-4	Memory Areas	27
1-5	Allocating I/O Bit Numbers	29
1-6	Preparations for Operation	30

1-1 Outline

The ZEN Programmable Relay is an extremely small programmable controller that provides 10 programmable I/O points (6 inputs and 4 outputs) to enable low-cost, small-scale automation. There is also a new model that provides 20 programmable I/O points (12 inputs and 8 outputs) along with 16 of each of the following: Timers, counters, displays, etc.

In this manual, the ZEN Programmable Relay is referred to as merely the "ZEN."

The ZEN comes in basically two types: LCD and LED.

- LCD Type: LCD screen and operation buttons
- LED Type: No LCD screen or operation buttons

The following pages provide a few examples of the way the ZEN meets a wide variety of application needs.

Low-cost, Small-scale Automatic Control

One CPU Unit provides 12 inputs and 8 outputs (with CPU Unit with 20 I/O points).

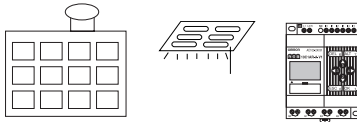

Water-supply facilities in apartments, lighting control in offices.

Easy Operation with an Inexpensive Controller

Ladder programming is possible directly from a LCD-type CPU Unit. Ladder programs can be easily copied to low-cost LED-type CPU Units by using Memory Cassettes (optional).

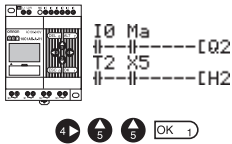

Smaller Control Panels

The ZEN is very small at 90 x 70 x 56 mm (H x W x D) and mounts essentially anywhere.

Note Dimensions are 90 x 122.5 x 56 mm (H x W x D) for CPU Units with 20 I/O points.

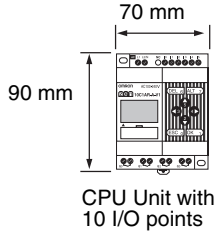

Less Assembly and Wiring Time Required for Control Panels

Simple one-touch DIN Track mounting. Built-in timers and counters so only power supply and I/O circuit wiring required.

Solid wires can be easily connected using only a screwdriver.

Refer to page 33.

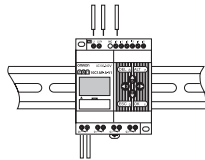

Future System Expandability

I/O capacity can be expanded to up to 24 inputs and 20 outputs by connecting 3 Expansion I/O Units.

Refer to page 9 and 33.

CPU Unit Expansion I/O Units (up to 3)

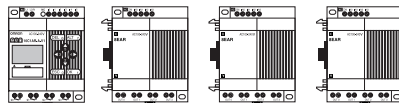

12 inputs/8outputs + (4 inputs/4outputs) × 3

Power Failure Countermeasures

EEPROM backs up the program and system settings data when no power is supplied to the ZEN.

Use a Battery Unit (optional) to back up work bits, holding timers, counters, and date/time data.

Refer to page 96.

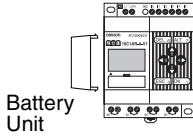

Easy Saving and Copying of Programs

Use an optional Memory Cassette to easily save and copy programs.

Refer to page 97.

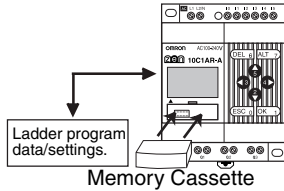

Programming and Monitoring from a Personal Computer

Windows-based ZEN Support Software is available and provides a complete simulation function.

Refer to page 99.

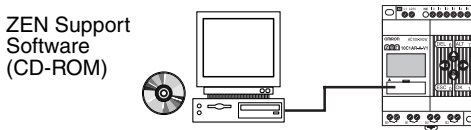

Greater Switching Capacity

The output contacts have 8-A switching capacity (250 VAC). All contacts are independent (for CPU Units with 10 I/O points).

Refer to page 45.

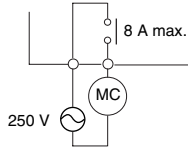

AC Inputs

For CPU Units with AC power supply inputs, 100 to 240 VAC can be directly connected.

Refer to page 35.

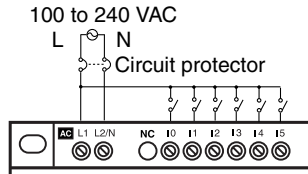

Easy Program Design

There are 4 different operations that can be set for bit outputs. Self-holding bits also can be easily programmed.

Refer to page 58.

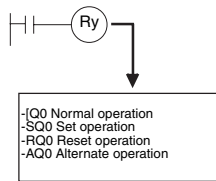

Complicated Timers without Additional Programming

Any of the 16 timers support 4 types of operation and 3 timing ranges.

There are also 8 built-in holding timers that hold data during power interruptions.

Refer to page 66.

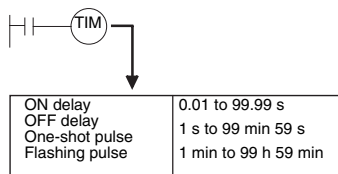

Incremental and Decremental Counters

There are 16 built-in counters that can be switched between incrementing and decrementing.

Use Comparators to enable programming multiple outputs from a counter.

Counters: Refer to page 69.

Comparators: Refer to page 78.

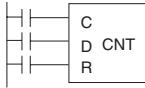

Control number of cars entering and leaving a car park.

Season- or Day-dependent Operating Times

CPU Units with built-in calendar and clock functions have 16 weekly timers and 16 calendar timers. Seasonal control is possible using calendar timers and day/time control is possible with weekly timers.

Weekly timers: Refer to page 71.

Calendar timers: Refer to page 73.

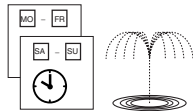

For gardens, parks, and recreational ponds.

Direct Analog Inputs

CPU Units with DC power supply inputs have 2 analog input points (0 to 10 V) and 4 analog comparators.

Refer to page 75.

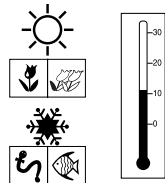

Temperature control for hot houses and tanks. Prevent freezing of swimming pools.

Easier Maintenance

Use the display function in LCD-type CPU Units to display user-set messages, the date, time, or other data. Button switches can also be used as input contacts. Applications include usage as a simple display operation panel.

Refer to page 80.

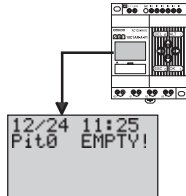

Longer Backlight for Dark Situations

The automatic cutout time for the backlight for LCD-type CPU Units can be set to 2, 10, or 30 minutes, or set to operate continuously. With the display function, the backlight can also be set to turn ON when a message is displayed.

Refer to page 92.

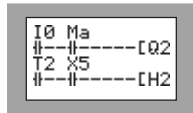

Prevent Chattering and Noise-related Malfunctions

Set the input filters to extend the filter timer and prevent malfunctions.

Refer to page 90.

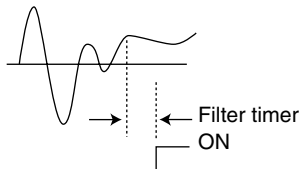

Exporting Systems Overseas

Display for LCD-type CPU Units is available in 6 languages. A Summertime function also supported.
 Changing display language: Refer to page 50.
 Summertime settings: Refer to page 93.

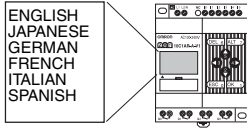

Programming Security

Programs can be protected by setting a password.
 Refer to page 88.

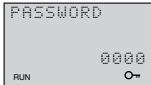

1-2 Features and Part Names

1-2-1 Features and System Configuration

The ZEN is small but has a wide range of functions and is easy to use. The ZEN facilitates small-scale automatic control.

LCD-type CPU Unit Features

- Simple button-operated programming.
- Highly visible, backlit LCD.
- Adjustable automatic cutout time for the backlight.
- Adjustable contrast for the LCD screen.
- Six-language display.
- Display function for user-set messages (4 lines x 12 characters), time, or timer, counter, or analog-converted value displays.
- Button switches allowing operation buttons to be used as input contacts.
- Built-in weekly and calendar timers to allow simple seasonal, daily, or time-based operation.

LCD-type and LED-type CPU Unit Features

- Both 100 to 240-VAC and 24-VDC power supply models available.
- Built-in analog comparator for temperature control and other analog applications (provided on CPU Units with DC power supply inputs, two analog inputs 0 to 10 V).
- Input filter settings to prevent noise-related malfunctions for both CPU Units and Expansion I/O Units.
- Program and settings data backed up on built-in EEPROM.
- Programming using ladder diagrams.
- Password function to protect programs.

Work bits, holding timer data, counter data, and date/time data will be backed up during long-term power supply interruptions if a Battery Unit (optional) is mounted.

ZEN-BAT01 Battery Unit

ZEN-ME01 Memory Cassette

Programs can be saved and copied by using a Memory Cassette (optional).

With CPU Units with 10 I/O points, up to 18 inputs and 16 outputs are possible if 3 Expansion I/O Units are connected.

With CPU Units with 20 I/O points, up to 24 inputs and 20 outputs are possible if 3 Expansion I/O Units are connected.

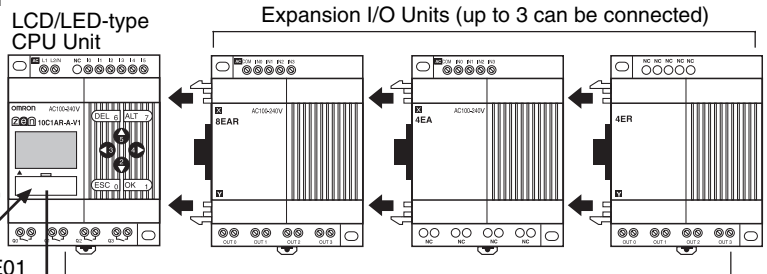

Relay outputs have large a switching capacity, (8A at 250 VAC), while transistor outputs can switch 0.5 A at 24 VDC.

All outputs have independent contacts except for CPU Units with 20 I/O points, which have one common for each 2 outputs for 4 of the 8 outputs.

Programs can be created, edited, saved, and printed, and operation can be simulated using the ZEN Support Software (optional).

1-2-2 Part Names

**LCD-type CPU Units with 10 I/O Points
(with LCD and Operation Buttons)**

Power supply	Inputs		Outputs	Input filter	Analog inputs	Calendar/time	Model number
100 to 240 VAC, 50/60 Hz	100 to 240 VAC	Not isolated	6 Relays	Yes	No	Yes	ZEN-10C1AR-A-V1
24 VDC	24 VDC		4 Transistors				Yes
		ZEN-10C1DT-D-V1					

Left Side

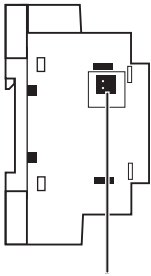

Battery Unit connector
(Remove the seal to connect the Battery Unit.)

Front

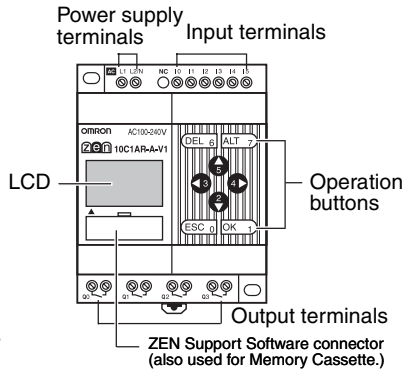

Right Side

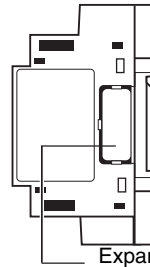

Expansion Unit connector cover.
Remove this cover to connect Expansion Unit.

**LCD-type CPU Units with 20 I/O Points
(with LCD and Operation Buttons)**

Power supply	Inputs		Outputs	Input filter	Analog inputs	Calendar/time	Model number	
100 to 240 VAC, 50/60 Hz	100 to 240 VAC	Not isolated	12 Relays	Yes	No	Yes	ZEN-20C1AR-A-V1	
24 VDC	24 VDC		8 Transistors				Yes	ZEN-20C1DR-D-V1
								ZEN-20C1DT-D-V1

Left Side

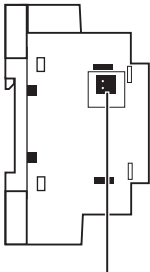

Battery Unit connector
(Remove the seal to connect the Battery Unit.)

Front

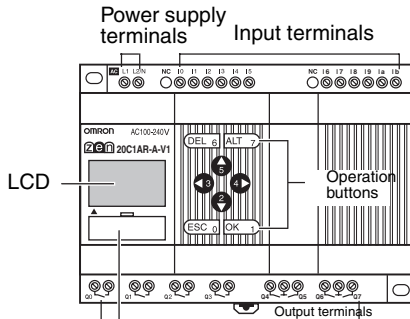

ZEN Support Software connector
(also used for Memory Cassette.)

Right Side

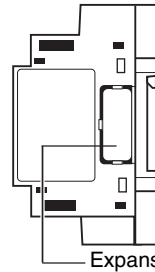

Expansion Unit connector cover.
Remove this cover to connect Expansion Unit.

**LED-type CPU Units with 10 I/O Points
(without LCD/Operation Buttons)**

The ZEN is also available in an LED type that provides full operating functionality, but no direct programming input. The ZEN Support Software or a Memory Cassette containing a program is required.

Power supply	Inputs		Outputs	Input filters	Analogue inputs	Calendar/time	Model number
100 to 240 VAC, 50/60 Hz	100 to 240 VAC	Not isolated	6 Relays	4 Yes	No	No	ZEN-10C2AR-A-V1
24 VDC	24 VDC		4 Transistors		Yes		ZEN-10C2DR-D-V1
					ZEN-10C2DT-D-V1		

Left Side

Front

Right Side

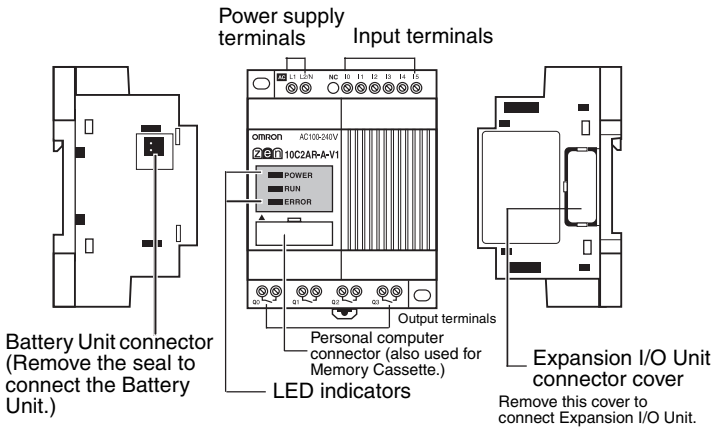

Indicators

Name	Color	Meaning	
POWER	Green	Lit	Power supplied
		Not lit	No power
RUN	Green	Lit	Operating (RUN)
		Not lit	Stopped (STOP)
ERROR	Red	Lit	Error
		Not lit	Normal

**LED-type CPU Units with 20 I/O Points
(without LCD/Operation Buttons)**

Power supply	Inputs		Outputs	Input filters	Analog inputs	Calendar/time	Model number
100 to 240 VAC, 50/60 Hz	100 to 240 VAC	Not isolated	Relays 8	Yes	No	No	ZEN-20C2AR-A-V1
24 VDC	24 VDC		Transistors		Yes		ZEN-20C2DR-D-V1
					ZEN-20C2DT-D-V1		

Left Side

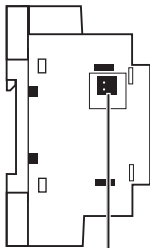

Battery Unit connector
(Remove the seal to connect the Battery Unit.)

Front

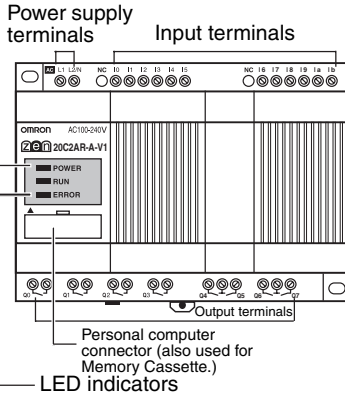

Right Side

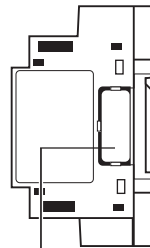

Expansion I/O Unit connector cover
Remove this cover to connect Expansion I/O Unit.

Indicators

Name	Color	Meaning	
POWER	Green	Lit	Power supplied
		Not lit	No power
RUN	Green	Lit	Operating (RUN)
		Not lit	Stopped (STOP)
ERROR	Red	Lit	Error
		Not lit	Normal

Differences between LCD- and LED-type CPU Units

Item		LCD type		LED type	
		AC power supply	DC power supply	AC power supply	DC power supply
Program editing, parameter settings, operation monitoring		Yes (Also possible with ZEN Support Software.)		Yes (ZEN Support Software required.)	
Operating mode switching		Yes (Also possible with ZEN Support Software)		Yes (ZEN Support Software required.)	
Calendar and clock function		Yes		No	
Bits	Input, output, work, holding bits	Yes		Yes	
	Timer, holding timer, counter	Yes		Yes	
	Weekly timer, calendar timer	Yes		No	
	Analog comparator	No	Yes	No	Yes
	Timer/counter comparator	Yes		Yes (ZEN Support Software required.)	
	Button switches	Yes		Yes	
	Display function	Yes		No	
Settings	Display language	Yes (Also possible with ZEN Support Software.)		-	
	Backlight cutout time	Yes (Also possible with ZEN Support Software.)		-	
	Input filters	Yes (Also possible with ZEN Support Software.)		Yes (ZEN Support Software required.)	
	Password	Yes (Also possible with ZEN Support Software.)		Yes (ZEN Support Software required.)	
Expansion I/O Unit connection		Yes		Yes	
Memory Cassette functions	ZEN to Memory Cassette transfer	Yes		No	
	Memory Cassette to ZEN transfer	Yes		Yes (Automatic transfer when power is turned ON.)	
	Memory Cassette initialization	Yes		No	
Battery Unit connection		Yes		Yes	
ZEN Support Software connection		Yes		Yes	

Expansion I/O Units

No. of I/O Points	Inputs			Outputs		Model
	100 to 240 VAC, 50/60 Hz	Isolated	4	Relays	4	
8 I/O	100 to 240 VAC, 50/60 Hz	Isolated	4	Relays	4	ZEN-8EAR
	24 VDC	Isolated	4	Relays	4	ZEN-8EDR
					Transistors	4
4 inputs	100 to 240 VAC, 50/60 Hz	Isolated	4	---	---	ZEN-4EA
	24 VDC	Isolated	4	---	---	ZEN-4ED
4 outputs	---	---	---	Relays	4	ZEN-4ER

Left Side

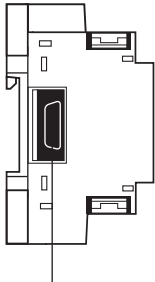

Expansion Unit connector

Front

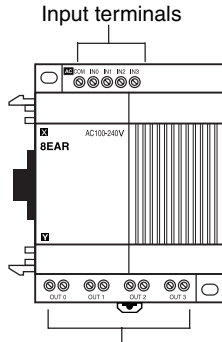

Input terminals

Output terminals

Right Side

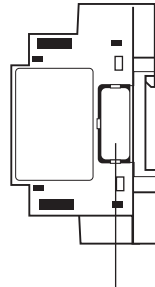

Expansion Unit connector cover.

(Remove this cover to connect Expansion I/O Unit.)

1-3 Display Screen and Basic Operations

The display screen for the LCD-type CPU Units and the operations of the buttons are shown below.

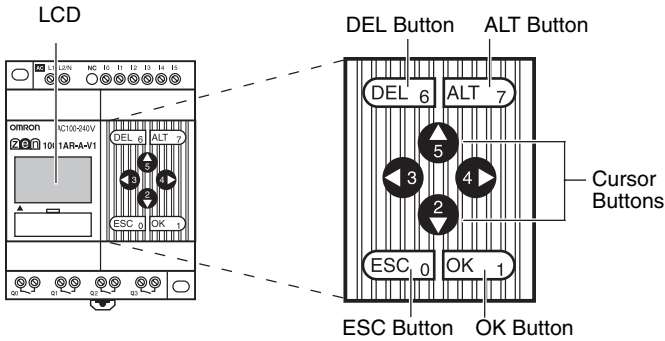

Icon Meanings



Icon	Meaning
RUN	Displayed while in RUN mode.
ERR	Indicates an error.
▲	Displayed when there is a higher-level menu or ladder program line than the one currently displayed.
▼	Displayed when there is a lower-level menu or ladder program line than the one currently displayed.
○—	Displayed when a password has been set.

Operation Button Names and Operations

Button	Function			
	Menus	Writing ladder program	Setting parameters	Button switch (See83.)
DEL	---	Deletes inputs, outputs, connection lines, and blank lines.	---	B6 ON
ALT	---	Switches between normally open and normally closed conditions. Changes to connection line write mode. Inserts a line.	---	B7 ON
Up	Moves the cursor up and down.	Moves the cursor up and down. Selects bit types and functions.	Moves the cursor up and down.	B5 ON
Down			Changes numerals and parameters.	B2 ON
Left	---	Moves the cursor right and left.	Moves the cursor right and left.	B3 ON
Right				B4 ON
ESC	Returns to the previous screen.	Cancels the setting and returns to the previous operation.	Cancels the setting and returns to the previous operation.	B0 ON
OK	Selects the menu item at the cursor position.	Confirms the setting.	Confirms the setting.	B1 ON

1-3-1 Screens

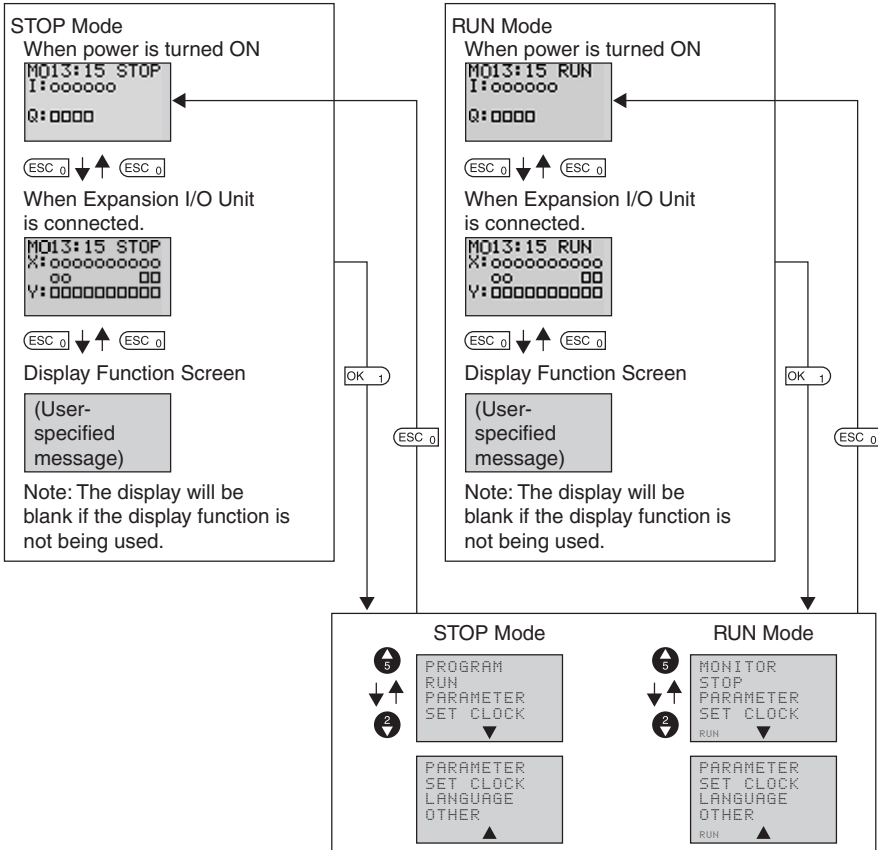

Display Screens

Main Screen

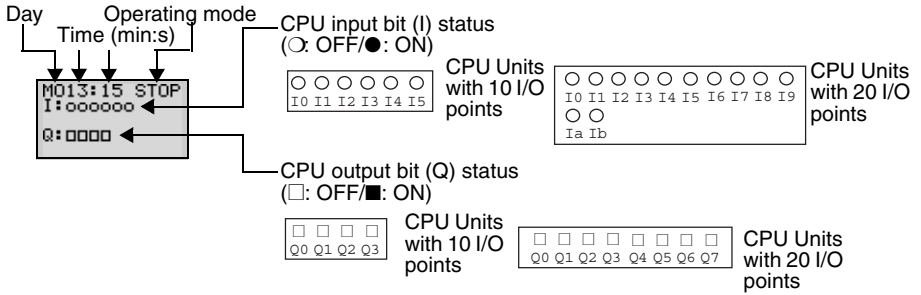

When One or More Expansion I/O Units Are Connected

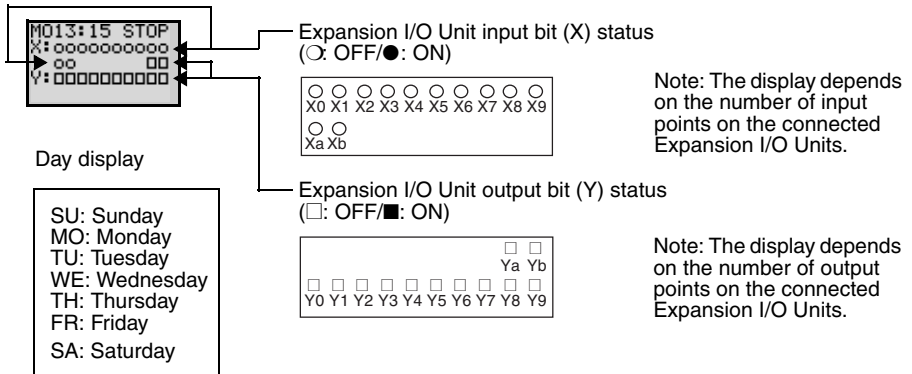

Menu Screen Configuration

RUN Mode

Ladder Monitor Screen

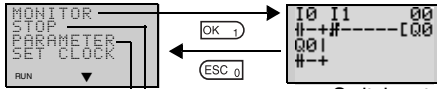

The ON/OFF status of input bits can be checked by monitoring the ladder program.

- Switches to STOP mode.
- The operation status of the timers, counters, and analog comparators can be monitored and the settings changed during operation. Refer to page 25.

STOP Mode

Ladder Program Edit Screen
(Refer to page 23.)

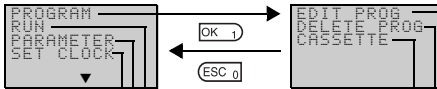

Creates and edits ladder program.

- Deletes ladder program and parameters.
- Memory Cassette Operation (Refer to page 97.)

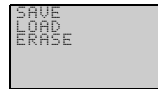

Transfers programs between ZEN and the Memory Cassette and initializes the Memory Cassette.

Note: Displayed only when a Memory Cassette is mounted.

- Switches to RUN mode.
- Changes the settings for timers, counters, and analog comparators. (Refer to page 28.)

Date and Time Settings (Refer to page 51.)



Sets the date and time.

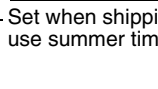

Set when shipping to countries that use summer time. (Refer to page 93.)

Display Language Settings (Refer to page 50.)

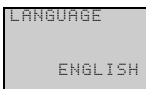

The display language can be changed. English, Japanese, German, French, Italian, and Spanish

Other Settings



Other settings can be made. Refer to the following page for details.

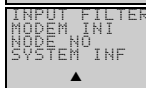

Other Submenus

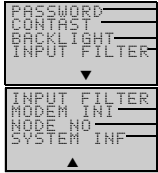

Setting Passwords (Refer to page 88.)

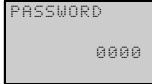

Set a password when you want to protect programs from being read. The password setting range is 0000 to 9999.

Adjusting Contrast (Refer to page 93.)



Adjust the contrast when the LCD screen is faint and difficult to read or when it is too dark to read. There are 5 contrast levels.

Changing Cutout Time for Backlight (Refer to page 92.)

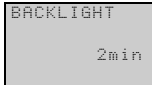

Set the automatic cutout time for the backlight in the LCD screen.
2 min, 10 min, 30 min, Always ON

Setting Input Filters (Refer to page 90.)

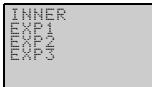

Set the input filters to ON or OFF for the CPU Unit or Expansion I/O Units. Set to ON when noise or chattering may affect operation.
“EXP1” to “EXP3” will be displayed depending on the number of Expansion I/O Units connected.

Do not use. For future system expansion.

Setting Node Number (Refer to page 99.)

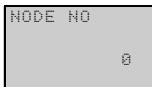

Set to the node number specified using the ZEN Support Software.

Reading System Information (Refer to page 94.)

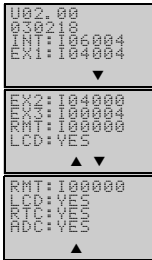

Read system information, such as the CPU Unit software version or the date it was created, the number of I/O points on the CPU Unit or the Expansion I/O Units, and whether or not LCD, RTC, or analog input functions are supported.

1-3-2 Basic Operation

Menu Selection Example

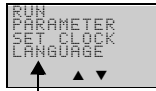
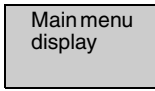

Flashing cursor

Use the **Up/Down** Buttons to move the cursor.

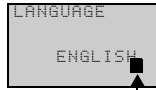

Highlighted cursor

Press the **OK** Button to select the flashing menu. The settings will flash on a reversed display.

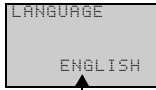

Flashing cursor

Press the **OK** Button to change from a highlighted cursor to a flashing cursor. Settings can now be changed.

Use the **Up/Down** Buttons to change the setting.

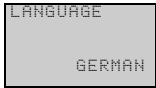

Use the **Up** Button to select **GERMAN**.

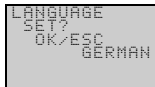

A confirmation message will be displayed asking if you want to change to German display.



Press the **OK** Button to change from English to German.



Press the **ESC** Button to cancel the change and return to the previous screen.

Example Operation in the Ladder Program Edit Screen

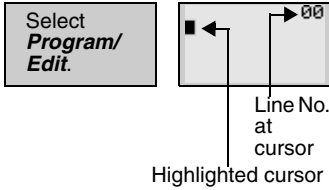

The highlighted cursor will appear in the initial write position. During highlighted cursor display, the cursor can be moved to the input or output write positions.

Up/Down Buttons: Move the highlighted cursor up and down.

Left/Right Buttons: Move the highlighted cursor Left/Right.

Press the **OK** Button at the input write position to display the input default setting IO and the normally open condition symbol. "I" will flash.

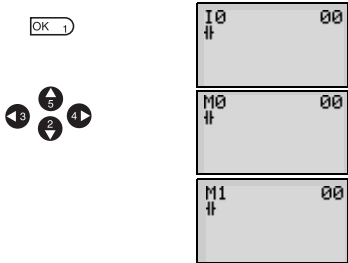

- Flashing Cursor at the I Position
Up/Down Buttons: Change the bit type.
Right Button: Moves the flashing cursor to the right.
OK Button: Sets the bit type and moves the flashing cursor to the bit address position.
- Flashing Cursor at the 0 Position
Up/Down Buttons: Change the bit address.
OK Button: Completes the writing of the bit.
- Switching between Normally Open and Normally Closed Conditions
You can use the ALT Button to switch between the N.O. and N.C. conditions, regardless of the position of the flashing cursor.

When the first input has been written, the highlighted cursor moves to the next input position.

Use the above procedure to enter program input conditions in series.

When writing serial inputs, the connecting line between inputs is drawn automatically.

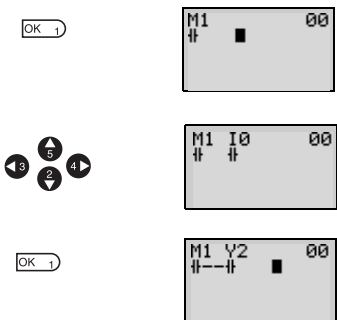

ALT 7

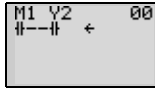

Press the **ALT** Button with the highlighted cursor in the input writing position to change the cursor to a flashing left arrow to enable connecting lines to be drawn.

Up/Down Buttons: Draw vertical connecting lines.

Left/Right Buttons: Draw horizontal connecting lines.

4 4

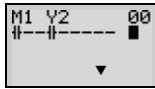

Press the **Right** Button twice to draw a line to the output bit. The cursor will change to a highlighted cursor at the output bit write position.

OK 1

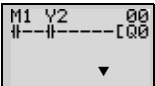

Press the **OK** Button at the output bit write position to display the default output Q0. Q will flash.

- Flashing Cursor at the Q (Bit Type) Position

Up/Down Buttons: Change the type of output

Right/Left Buttons: Move the flashing cursor.

OK Button: Sets the bit type and moves the flashing cursor to the bit address position.

- Flashing Cursor at the (Additional Output Function) Position

Up/Down Buttons: Selects the additional output function

OK Button: Sets the additional output function and moves the flashing cursor to the bit address position.

- Flashing Cursor at the 0 (Bit Address) Position

Up/Down Buttons: Select the bit address

OK Button: Completes the output write.

5 3 2 4

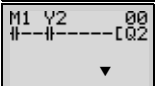
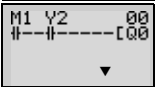

OK 1



OK 1

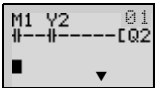

Press the **OK** Button to complete the bit write and to move the highlighted cursor to the first input position ON the next line.

ESC 0

Press the **ESC** Button to complete the writing of the ladder program and to return to the menu screen.

Example Parameter Settings Screen Operation

Select **Parameters** on menu screen.

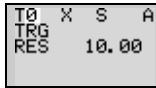

When *Parameter* is selected, the parameter settings are displayed.

(1) Selecting Parameters to Display

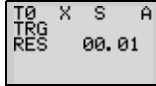

Press the **OK** Button to change the high-lighted cursor to a flashing cursor.

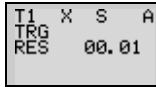

Use the **Up/Down** Buttons to select another timer.

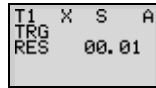

When multiple parameters of the same type have been selected, use the **Up/Down** Buttons to scroll through the numbers.

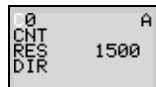

Press the **Left** Button to switch to another type, move the flashing cursor to the bit type position and use the **Up/Down** Buttons to select the bit type.

Move the flashing cursor to the bit type position and use the **Up/Down** Buttons to select another bit type.

(2) Setting and Changing Parameters

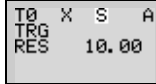
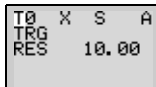

Use the **Left/Right** Buttons to move the high-lighted cursor to the parameter to be set.

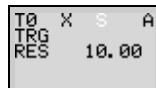

Press the **OK** Button to confirm the set position. The cursor will change to a flashing cursor.

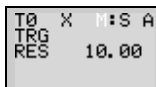

Use the **Up/Down** Buttons to set the parameter.

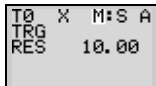

Press the **OK** Button to confirm the setting.

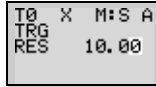

Use the **Left/Right** or **Up/Down** Buttons to move the highlighted cursor to the parameter to be set.

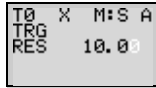

Press the **OK** Button to confirm the set position. The cursor will change to a flashing cursor.

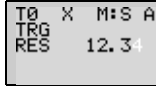

Use the **Left/Right** Buttons to select the digit to be set.

Use the **Up/Down** Buttons to change the value of each digit.

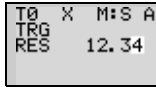

Press the **OK** Button to confirm the setting.



Press the **ESC** Button to complete the settings.

Note If the **ESC** Button is pressed while ladder program or parameter settings are being input, the input to that point will be canceled and the settings will return to the original settings.

1-4 Memory Areas

I/O, Work, and Internal Holding Bits

Name	Type	Bit addresses	No. of bits	Function		Ladder programs	Page
CPU Unit input bits	I	0 to 5	6	CPU Units with 10 I/O pts	Reflect the ON/OFF status of the input devices connected to the CPU Unit input terminals.	N.O./N.C. inputs	29
		0 to b	12	CPU Units with 20 I/O pts			
Expansion I/O Unit input bits	X	0 to b	12	Reflect the ON/OFF status of the input devices connected to the Expansion I/O Unit input terminals.			29
Button switches	B	0 to 7	8	Turn ON when the operation buttons are pressed in RUN mode. Can only be used for LCD-type CPU Units.			83
Analog comparator bits	A	0 to 3	4	Output the comparison result for analog inputs. Can only be used for models with a 24-VDC power supply.			75
Comparator bits	P	0 to f	16	Compare the present value of timers (T), holding timers (#), and counters (C), and outputs the comparison result.			78
CPU Unit output bits	Q	0 to 3	4	CPU Units with 10 I/O pts	Output the ON/OFF status of the output bits to the outputs devices connected to the CPU Unit.	N.O./N.C. inputs Outputs (See note.)	29
		0 to 7	8	CPU Units with 20 I/O pts			
Expansion I/O Unit output bits	Y	0 to b	12	Output the ON/OFF status of the output bits to the outputs devices connected to the Expansion I/O Unit.			29
Work bits	M	0 to f	16	Can only be used within the program. Cannot output to an external device.			-
Holding bits	H	0 to f	16	Same as for work bits however the holding bits maintain ON/OFF status when power is turned OFF.			-

Note The following additional functions can be selected for bit outputs.

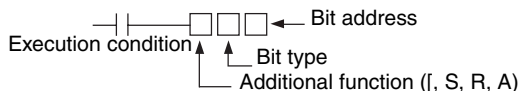

[Normal output	Turns ON or OFF according to the ON/OFF status of the execution condition.
S	Set	Holds ON status after the execution condition turns ON once.
R	Reset	Holds OFF status after the execution condition turns ON once.
A	Alternate	Alternates between ON and OFF whenever the execution condition turns ON (input latch operation).

Timers and Counters

Name	Type	Bit addresses	No. of timers/counters	Function	Use in ladder programs	Page
Timer	T	0 to f	16	Can be switched between ON delay, OFF delay, one-shot, and flashing pulse operation.(See note.)	N.O./N.C. condition	66
Holding timer	#	0 to 7	8	Holds the present value during counting even if the trigger input or power supply is turned OFF. Continues the timing when the trigger input or power supply is turned ON again.		66
Counter	C	0 to f	16	Reversible counters that can be incremented and decremented.		69
Weekly timer	@	0 to f	16	Can turn ON or OFF during a specified day or time period.		71
Calendar timer	*	0 to f	16	Can turn ON or OFF during a specified date period.		73

- Note**
1. The above memory areas are smaller for pre-V1 CPU Units.
 2. Timers can switch between operations. Refer to page 59.

X	ON delay	Times down while the trigger input is ON and turns ON the timer bit when the set time is reached.
■	OFF delay	Turns ON the timer bit while the trigger input is ON, starts timing down when the trigger input turns OFF, and turns OFF the timer bit when the set time is reached.
O	One-shot	Turns ON the timer bit for the set period when the trigger input changes from OFF to ON only.
F	Flashing pulse	Timer bit repeatedly turns ON/OFF at set intervals while the trigger input is ON.

Display Bits

Name	Type	Bit addresses	No. of bits	Function	Use in ladder programs	Page
Display	D	0 to f	16	Display user-set character strings, times, timer present values, counter present values, or analog-converted values.	Output	80

Note The above memory area is smaller for pre-V1 CPU Units.

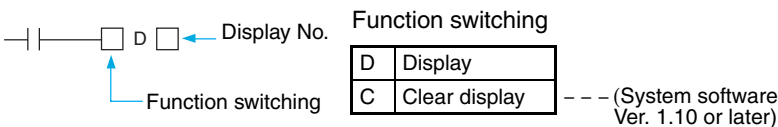

1-5 Allocating I/O Bit Numbers

For CPU Units with 10 I/O points, the input bit addresses I0 to I5 and output bit addresses Q0 to Q3 are always allocated to the CPU Unit.

For CPU Units with 20 I/O points, the input bit addresses I0 to Ib and output bit addresses Q0 to Q7 are always allocated to the CPU Unit.

Up to 3 Expansion I/O Units can be added and input bit addresses X0 to Xb and output bit addresses Y0 to Yb are allocated in the order the Units are connected.

Connection Example for 4-point Expansion Input Unit, 4-point Expansion Output Unit, and 8-point Expansion I/O Unit

■ CPU Units with 10 I/O Points

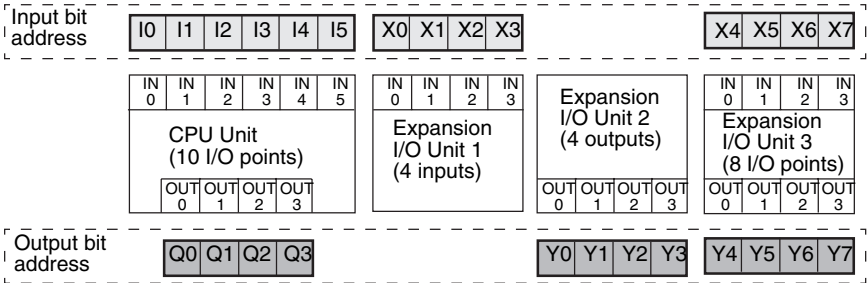

■ CPU Units with 20 I/O Points

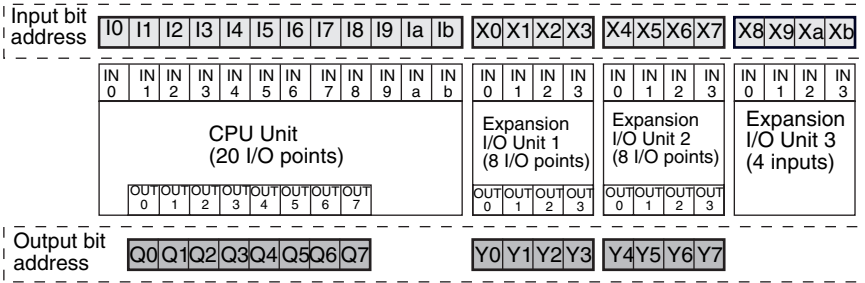

Note When an Expansion I/O Unit that does not have both inputs and outputs, such as the 4-point Input Unit and the 4-point Output Unit shown in the above diagram, the unused bit addresses are not allocated to that Unit and are used for the next Unit.

1-6 Preparations for Operation

Mount ZEN to Control Panels

The ZEN can be mounted to either a DIN Track or directly onto the surface of the control panel. Refer to page 32.



Connect Power Supply, Input, and Output Devices

Wire the ZEN to the power supply, input, and output devices. Refer to page 33.



Make Initial Settings

Make the settings required before programming, such as date, time, and display language. Refer to pages 50 and 51.



Write Program

Input the ladder program, including timers, counters, and other parameters. Use the ZEN Support Software when using the LED-type CPU Units (without LCD or operation buttons.) Refer to page 52.



Check Program Execution

Perform trial operation before starting actual operation and check that the system is operating correctly. Refer to page 61.



Save Program

Debugged programs and all parameters should be saved to a Memory Cassette or ZEN Support Software to prevent loss of the data. Refer to page 97.



Actual Operation

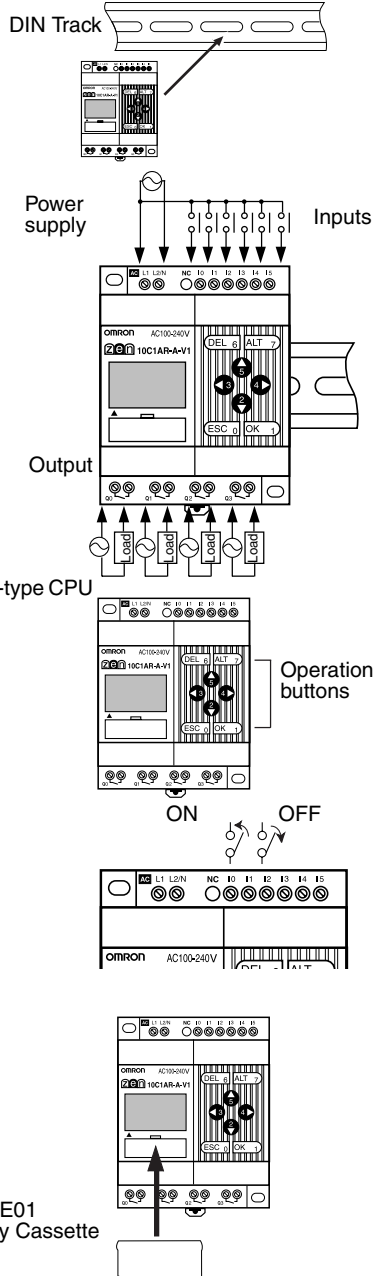

SECTION 2

Installation and Wiring

This section explains how to mount and wire the ZEN CPU Units and Expansion I/O Units.

2-1	Mounting	32
2-1-1	Installation Method	32
2-1-2	Connecting Expansion I/O Units	33
2-2	Wiring	33

2-1 Mounting

2-1-1 Installation Method

Always mount the ZEN inside a control panel. The ZEN can either be mounted to the surface of the control panel or onto DIN Track.

Orientation

Do not mount the ZEN in any orientation other than the one shown in the following diagram.

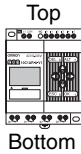

Mounting to DIN Track

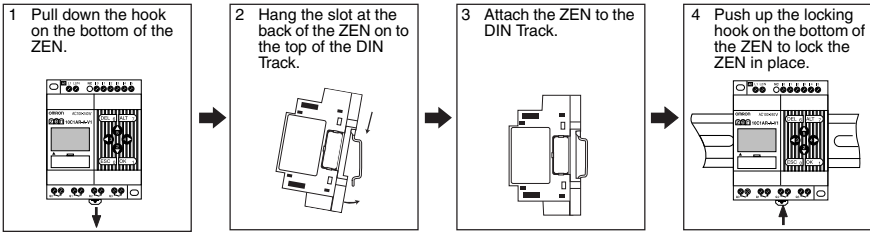

Mounting Inside a Control Panel

Use M4 screws to mount the ZEN.

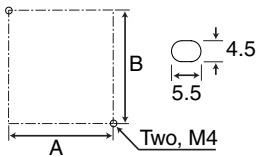

Mounting Dimensions (Unit: mm)

Unit		A	B
CPU Unit	CPU Units with 10 I/O points	60	80
	CPU Units with 20 I/O points	112.5	80
Expansion I/O Unit	Units with 8 I/O points	60	80
	Units with 4 inputs		
	Unit with 4 outputs		

2-1-2 Connecting Expansion I/O Units

Up to 3 Expansion I/O Units can be connected.

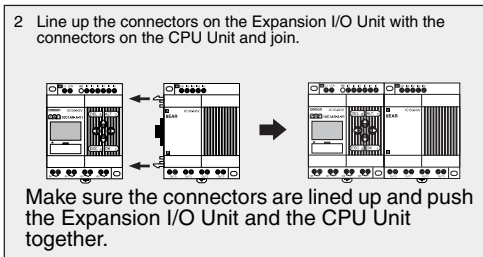
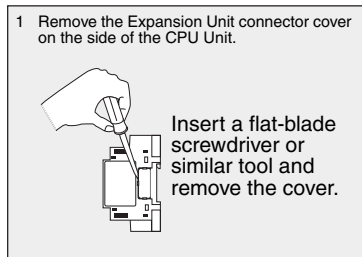

- Note**
1. Do not remove the Expansion Unit connector cover on the right edge of the connected Expansion Unit.
 2. Be careful when inserting the screwdriver that you do not insert it too far and damage the base or the elements.

2-2 Wiring

General Wiring Precautions

External Wiring

Do not run ZEN I/O lines in the same duct or conduit as power lines.

■ Hanging Ducts

Leave at least 300 mm between the power cables and the I/O or control wiring, as shown in the following diagram.

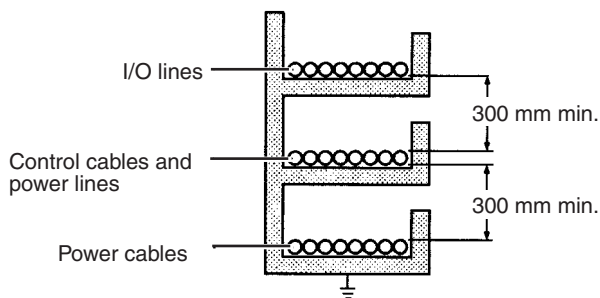

■ **Floor Ducts**

Leave at least 200 mm between the wiring and the top of the duct, as shown in the following diagram.

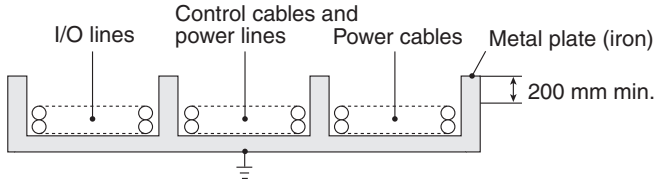

■ **Conduits**

Separate the ZEN I/O lines, power and control lines, and power cables, as shown in the following diagram.

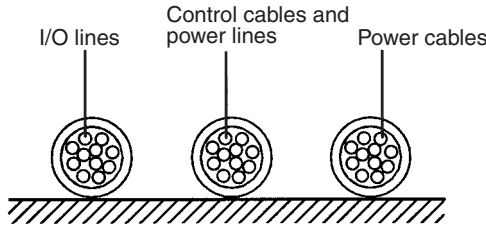

Do not run ZEN I/O lines in the same duct or conduit as power lines.

Connectable Wires

- A terminal block designed for solid wires is used. Use solid wires when wiring.

	Solid wires	Stranded wires	Straight terminals
One-line connection	0.2 to 2.5 mm ²	0.2 to 2.5 mm ² (Equivalent to AWG 24 to 14.)	0.25 to 2.5 mm ²
Two-line connection	0.2 to 0.75 mm ²	0.2 to 0.75 mm ² (Equivalent to AWG 24 to 19)	0.25 to 0.75 mm ²

- Strip the sheath back 6.5 mm.

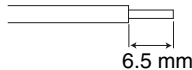

- Twisted wires can cause shorts so never directly connect twisted wires. Always connect a straight crimp terminal if using twisted wires.

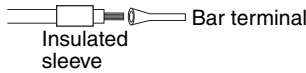

- Use a flat-blade screwdriver to tighten the terminal block screws.

Wiring Power Supply and Input Lines

AC Power Supplies

⚠ WARNING Do not connect the isolated side (L) and the grounded side (N) in reverse. Wire the L side to the AC input circuit.

⚠ Caution Tighten the AC power supply terminals to a torque of 0.5 to 0.6 N·m. Loose screws can result in fire or faulty operation.

■ CPU Units with 100 to 240-VAC Power Supplies

- To prevent voltage drops due to starting currents and inrush currents in other devices, wire the ZEN power supply circuit separately from other power circuits.
- When using more than one ZEN, to prevent voltage drops due to inrush current and circuit-breaker malfunctions, it is recommended that each one is wired separately.
- To prevent the influence of noise from power lines, twist the power lines. Wiring via a 1-to-1 isolation transformer is also effective.
- Use wires that are thick enough to allow for voltage drops and current variations within the allowable range.

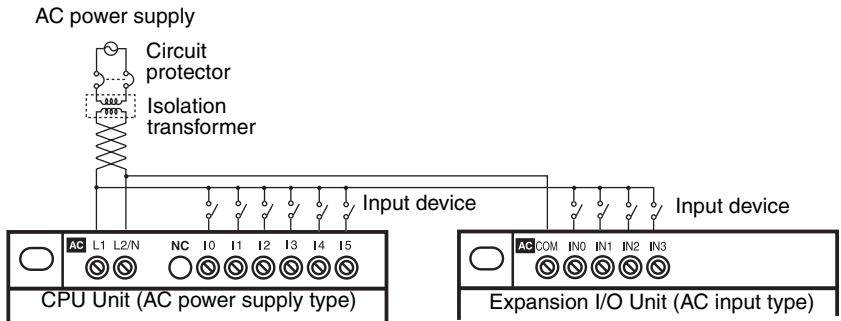

CPU Units with 10 I/O Points (V1 and Pre-V1 Models)

100 to 240 VAC, 50/60 Hz, 30 VA

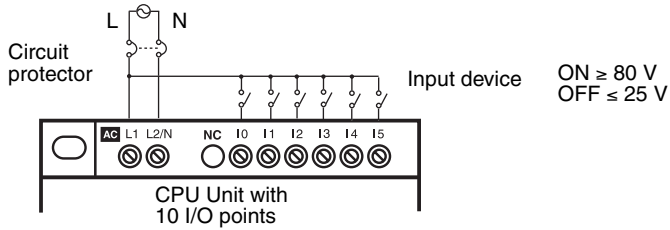

CPU Units with 20 I/O Points

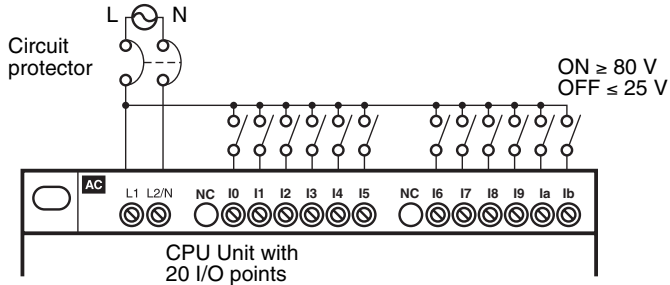

■ **Expansion I/O Units**

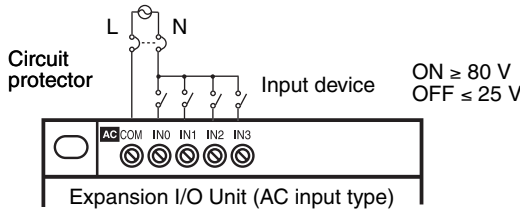

Note

1. Observe the power supply polarity when wiring the power supply and the input circuits. The input signals cannot be read if the polarity is incorrect.
2. Include a circuit protector or breaker for the ZEN in the power supply circuit.
3. There are no restrictions on the polarity of the inputs on the Expansion I/O Units.
4. A two-wire sensor cannot be connected directly to the AC input. To connect a two-wire sensor, attach an external bleeder resistance in the way shown below.

- Example: Connecting to a CPU Unit

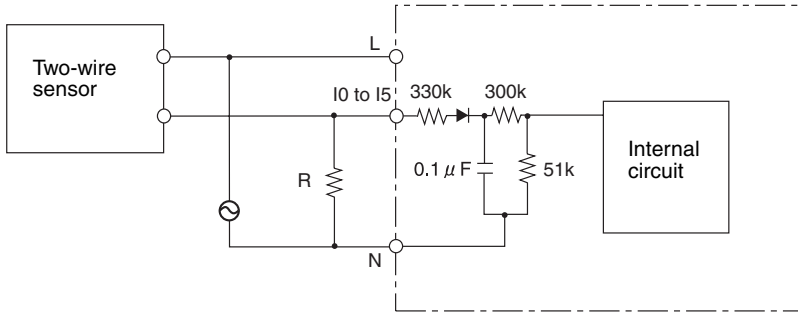

- Example: Connecting to an Expansion I/O Unit

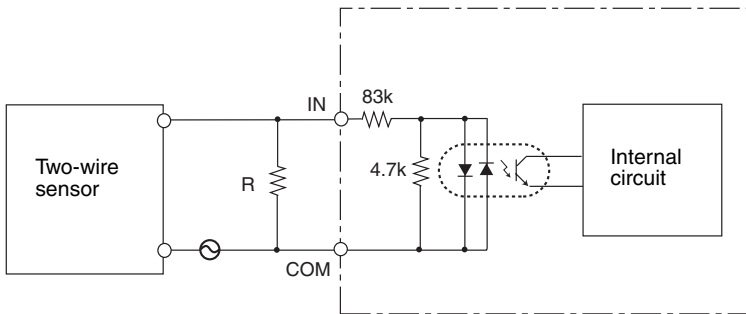

- a) Use a resistance that satisfies both of the following conditions.

$$R (\Omega) \leq \frac{\text{Max. OFF-voltage for AC input (25 VAC)}}{\text{Sensor's max. leakage current}}$$

$$R (\Omega) \leq \frac{\text{Voltage supplied to sensor}}{\text{Min. current for which the sensor's OFF residual voltage is less than 25 V}}$$

- b) Because of heat generation, use a resistor with at least the following wattage.

$$P (W) \geq \frac{(\text{Voltage supplied to sensor})^2}{\text{Resistance value}} \times 3 \text{ (allowance factor)}$$

DC Power Supplies

■ CPU Units with 10 I/O Points

Connecting a Negative Common (V1 CPU Units)

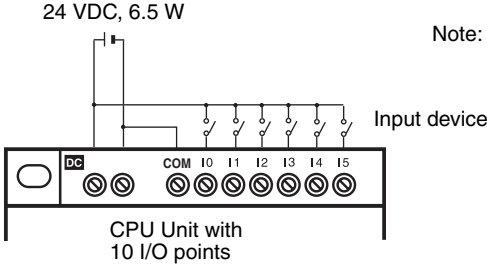

Note: Supply power to the COM terminal at the same time as to the power supply terminal.

Connecting Analog Input Devices (Input Range: 0 to 10 V) to Input Terminals I4 and I5

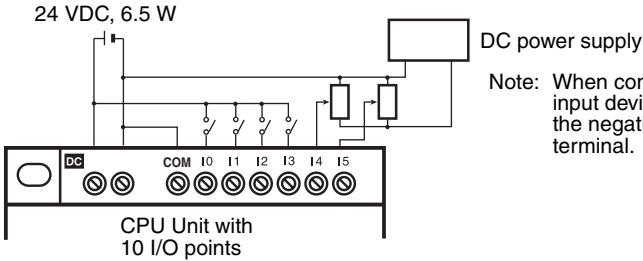

Note: When connecting an analog input device, always connect the negative side to the COM terminal.

Connecting Positive Common (V1 CPU Units Only)

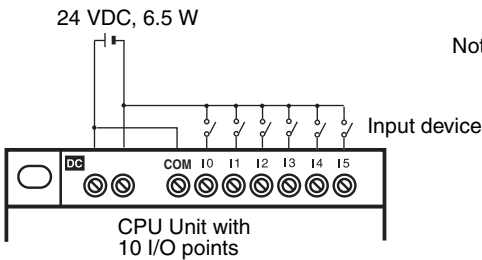

Note: 1. If a positive common is used, analog input devices cannot be connected to I4 and I5.
2. Supply power to the COM terminal at the same time as to the power supply terminal.

Connecting to Pre-V1 CPU Units

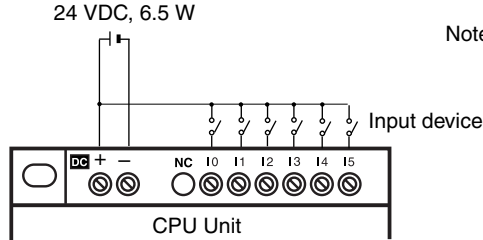

Note: With pre-V1 CPU Units, the negative side of the power supply circuit is connected internally as the common for the input circuits. Input circuits cannot be connected with a positive common; they will not work.

Connecting Analog Inputs (Input Range: 0 to 10 V) to Input Terminals I4 and I5 (Pre-V1 CPU Units)

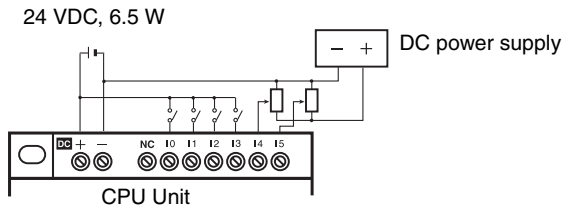

■ **CPU Units with 20 I/O Points**

Connecting a Negative Common (V1 CPU Units)

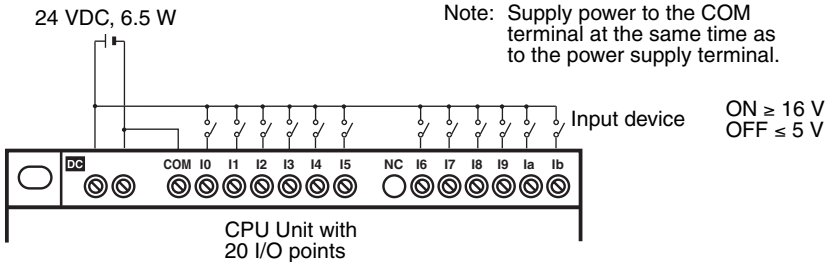

Connecting Analog Input Devices (Input Range: 0 to 10 V) to Input Terminals Ia and Ib

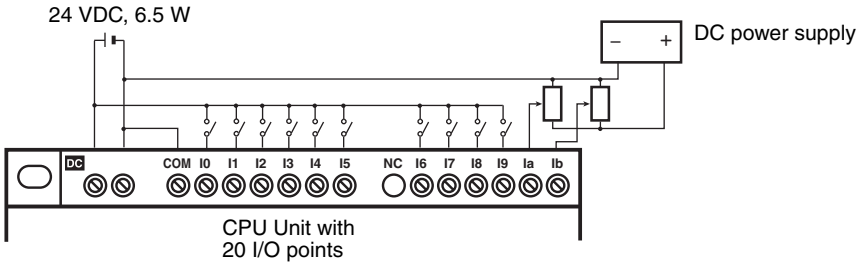

Connecting Positive Common (V1 CPU Units Only)

- Note: 1. If a positive common is used, analog input devices cannot be connected to Ia and Ib.
 2. Supply power to the COM terminal at the same time as to the power supply terminal.

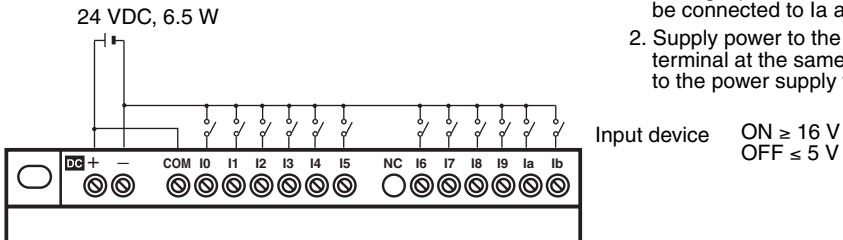

■ **Expansion I/O Units**

24 VDC, 6.5 W

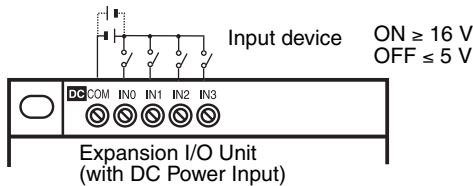

Note Either a positive or negative common can be connected with Expansion I/O Units.

Precaution

1. Do not connect the + and - DC power supply in reverse on CPU Units with DC power supplies.
2. With V1 CPU Units, both PNP and NPN sensors can be connected to DC input circuits.

Connecting PNP Sensors

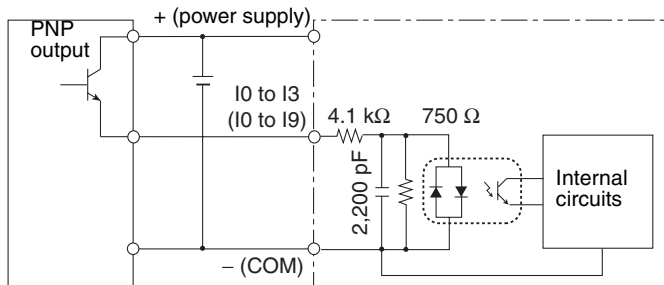

Connecting NPN Sensors

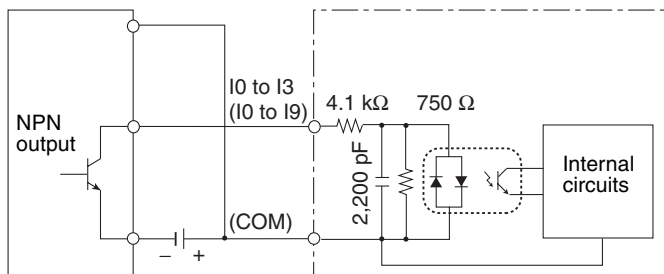

Input Devices

The following table shows how to connect various input devices.

Device	Circuit diagram
Relay output	
NPN open collector	
NPN current output	
PNP current output	
Voltage output	

Note Do not use the following wiring with voltage-output devices:

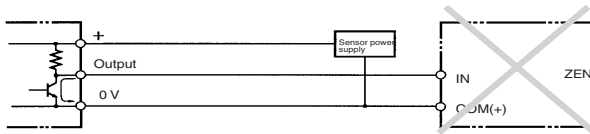

3. Use only PNP sensors for pre-V1 CPU Units. NPN sensors cannot be connected directly. To connect an NPN sensor, connect it through a relay or connect external resistance, as shown below. Be sure to allow for the reverse logic that will result from this type of connection

- Connecting to I0 to I3

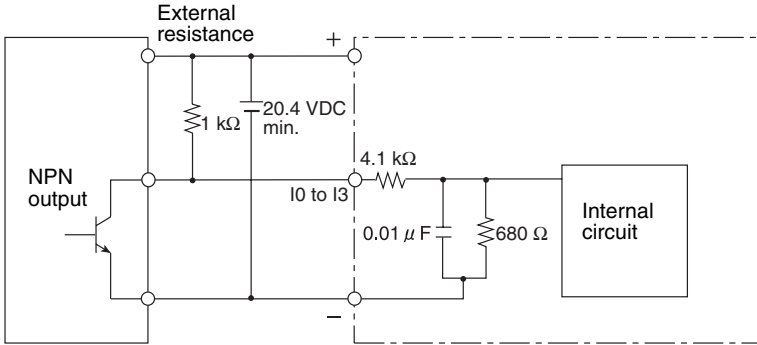

- a) When an NPN sensor is connected, use an external resistance R of at least $1\text{ k}\Omega$ and 2 W .
- b) Use a power supply voltage of at least 20.4 VDC for the sensor.

- Connecting to I4/I5

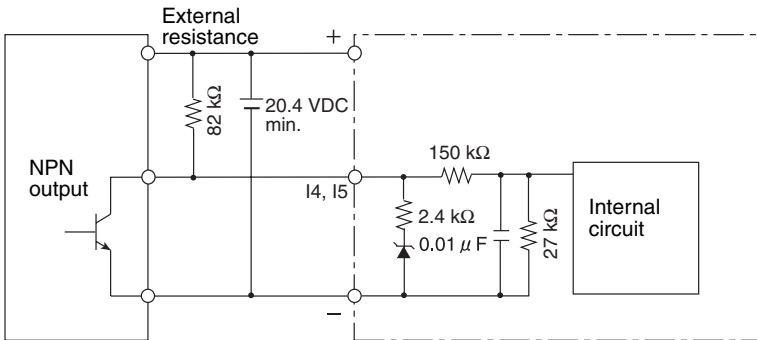

- c) When an NPN sensor is connected, use an external resistance R of at least $82\text{ k}\Omega$ and $1/8\text{ W}$.
- d) Use a power supply voltage of at least 20.4 VDC for the sensor.
- e) Do not input a negative ($-$) signal to the analog inputs (I4, I5). The internal elements may be damaged if a negative signal is input.

■ **Leakage Current from Input Devices**

A leakage current can cause false inputs when using 2-wire sensors (proximity switches or photoelectric switches) or limit switches with LEDs. False inputs won't occur if the leakage current is less than 1.0 mA. If the leakage current exceeds this value, insert a bleeder resistor in the circuit to reduce the input impedance, as shown in the following diagram.

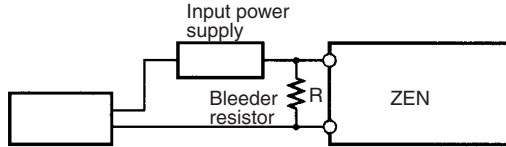

2-wire sensor, etc.

- I: Device's leakage current (mA)
- R: Bleeder resistance (kΩ)
- W: Bleeder resistor's power rating (W)
- L_C: ZEN's input impedance (kΩ)
- I_C: ZEN's input current (mA)
- E_C: ZEN's OFF voltage (V) = 5.0 V

$$R = \frac{L_C \times 5.0}{I \times L_C - 5.0} \text{ k}\Omega \text{ max.} \quad W = \frac{2.3}{R} \text{ W min.}$$

The equations above were derived from the following equations:

$$I \times \frac{R \times \frac{\text{Input voltage (24)}}{\text{Input Current (I}_C)}}{R + \frac{\text{Input voltage (24)}}{\text{Input Current (I}_C)}} \leq \text{OFF voltage (E}_C: 5.0)$$

$$W \geq \frac{\text{Input voltage (24)}}{R} \times \text{Input voltage (24)} \times \text{tolerance (4)}$$

Refer to page 112 *Input Specifications* for details on the values L_C, I_C, and E_C. The input impedance, input current, and OFF voltage may vary depending on the input being used. (IN00000 through IN00002 have different values.)

■ **Inductive Loads**

When connecting an inductive load to an input, connect a diode in parallel with the load. The diode should satisfy the following requirements:

1,2,3...

1. Peak reverse-breakdown voltage must be at least 3 times the load voltage.
2. Average rectified current must be 1 A.

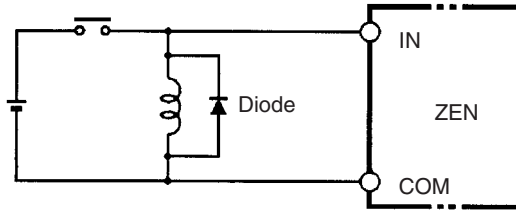

Wiring Output Circuits

(1) Relay Output Type

For CPU Units with 10 I/O points, all 4 outputs in the relay output circuits have independent contacts. For CPU Units with 20 I/O points, outputs Q0 to Q3 in the relay output circuits have independent contacts and outputs Q4 to Q7 have 2 points per common.

There are no particular restrictions on polarity.

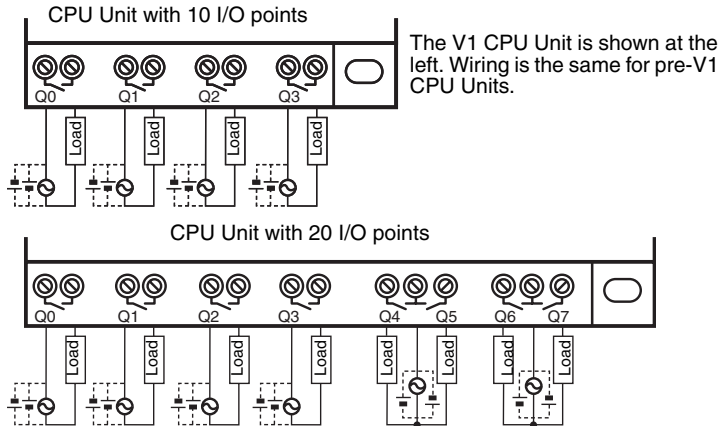

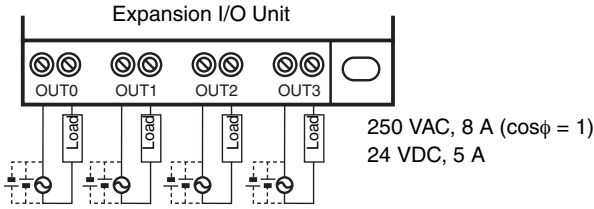

(2) Transistor Output Type

For CPU Units with 10 I/O points and Expansion I/O Units, all 4 outputs in the transistor output circuits have independent circuits. For CPU Units with 20 I/O points, outputs Q0 to Q3 in the transistor output circuits have independent circuits and outputs Q4 to Q7 have 2 points per common.

The terminals have polarity given on the terminal block, but no problem will result from reversing the connection positions of the power supply and load.

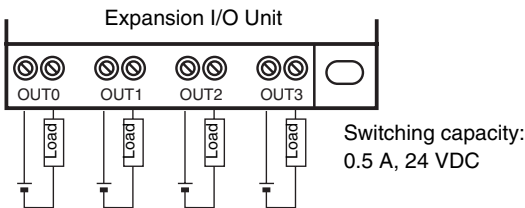
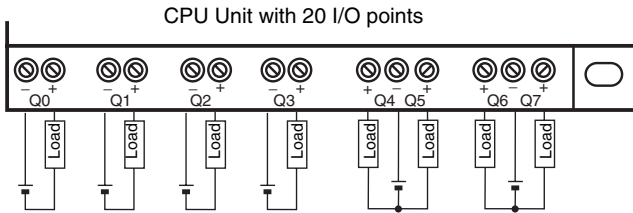
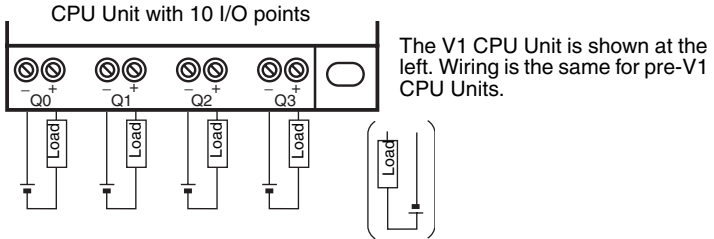

Output Wiring Precautions

Output Short Circuit Protection

We recommend adding a protective fuse to all output circuits to protect the output elements and PCBs from burning if the load connected to the output terminal short-circuits.

Inductive Loads

When connecting an inductive load to an input, connect a surge protector or diode in parallel with the load.

The surge protector's components should have the following ratings:

Relay Output

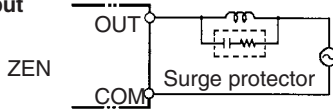

Relay Output (Transistor Output)

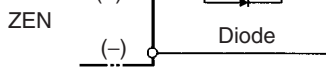

Relay Output (Transistor Output)

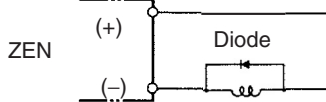

The diode should satisfy the following requirements:

Peak reverse-breakdown voltage must be at least 3 times the load voltage.

Average rectified current must be 1 A.

Inrush Current Considerations

When switching a load with a high inrush current in the ZEN relay output or transistor output model, such as an incandescent lamp, suppress the inrush current as shown below.

Countermeasure 1

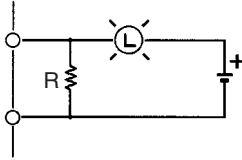

Providing a dark current of approx. one-third of the rated value through an incandescent lamp

Countermeasure 2

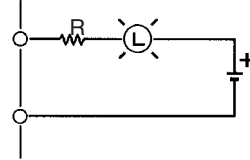

Providing a limiting resistor

Fuse Insertion

The ZEN with transistor output may burn if the load is short-circuited, therefore, insert a protective fuse in series to the load.

SECTION 3

Programming and Operating Methods

This section explains how to create and edit ladder programs and how to use the timers, counters, comparators, display function and buttons switches.

3-1	Selecting Display Language	50
3-2	Setting the Date and Time	51
3-3	Creating Ladder Programs	52
3-3-1	I/O Wiring and Internal Operation	53
3-3-2	Clearing Programs	53
3-3-3	Writing Ladder Programs	54
3-4	Confirming Ladder Program Operation	61
3-5	Correcting Ladder Programs	64
3-5-1	Changing Inputs	64
3-5-2	Changing Additional Bit Output Functions	64
3-5-3	Deleting Inputs, Outputs, and Connection Lines	65
3-5-4	Inserting Lines	65
3-5-5	Deleting Blank Lines	66
3-6	Using Timers (T) and Holding Timers (#)	66
3-6-1	Settings in the Ladder Program Edit Screen	68
3-6-2	Settings in the Parameter Settings Screen	68
3-6-3	Parameter Monitor Screen Display	69
3-7	Using Counters (C)	69
3-7-1	Settings in the Ladder Program Edit Screen	69
3-7-2	Settings in the Parameter Settings Screen	70
3-7-3	Parameter Monitor Screen Display	71
3-8	Using Weekly Timers (@)	71
3-8-1	Settings in the Ladder Program Edit Screen	72
3-8-2	Settings in the Parameter Settings Screen	72
3-8-3	Parameter Monitor Screen Display	73
3-9	Using Calendar Timers (*)	73
3-9-1	Settings in the Ladder Program Edit Screen	74
3-9-2	Settings in the Parameter Settings Screen	74
3-9-3	Parameter Monitor Screen Display	75
3-10	Analog Inputs (Analog Comparators (A))	75
3-10-1	Settings in the Ladder Program Edit Screen	76
3-10-2	Settings in the Parameter Settings Screen	77
3-10-3	Parameter Monitor Screen Display	77
3-11	Comparing Timer/Counter Present Values Using Comparators (P)	78
3-11-1	Settings in the Ladder Program Edit Screen	78
3-11-2	Settings in the Parameter Settings Screen	79
3-11-3	Parameter Monitor Screen Display	80
3-12	Displaying Messages (Display Bits (D))	80
3-12-1	Settings in the Ladder Program Edit Screen	81
3-12-2	Settings in the Parameter Settings Screen	81
3-13	Using Button Switches (B)	83

3-1 Selecting Display Language

There is a choice of 6 display languages for LCD-type CPU Units. The default language is English.

Operation to Select German

Turn ON the power.

OK →

Press the **OK** Button to change to the Menu Screen.

⬇ ⬇ ⬇ ⬇

Press the **Down** Button 4 times to move the cursor to "LANGUAGE".

OK →

Press the **OK** Button to display the current language ("ENGLISH"). The final "H" will be highlighted and flashing.

OK →

Press the **OK** Button to make the whole word "ENGLISH" flash. A different language can now be selected.

Use the **Up/Down** Buttons to select a language.

⬆ ⬆

Press the **Up** Button to select **GERMAN**.

OK →

Press the **OK** Button to display a confirmation message.

Press **OK** to set the new language.

OK →

The display language will change to German.

Press the **OK** Button to complete the setting.

3-2 Setting the Date and Time

The date and time are not set when the product is shipped. The date and time must be set for models with calendar and time functions before the ZEN can be used.

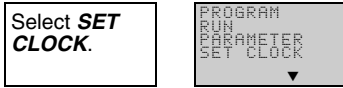

OK →



Press the **OK** Button to display the submenu for clock settings. Select **SET CLOCK** from the submenu.

OK →



Press the **OK** Button to display the current date and time settings. The right digit of the date will be highlighted and flashing.

Current date: yy/mm/dd

Current time: hh:mm (day)

OK →

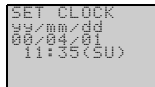

Set the date and time.

Use the **Up/Down** Buttons to change the setting.

Use the **Left/Right** Buttons to move the cursor.

The day will automatically change when the date is set.

OK →

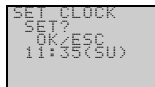

Press the **OK** Button to display a confirmation message.

OK →

Press the **OK** Button to confirm and complete the setting.

⚠ Caution If the power supply is turned OFF for an extended period of time (2 days or more at 25°C), the date and time will return to the default setting (00/1/1; 00:00 (SA)). This may cause programs using calendar timers or weekly timers to malfunction. Therefore, mount a Battery Unit for the system if the power supply is expected to be interrupted for an extended time. (Refer to page 96.)

- Note**
1. The year can be set between 2000 and 2099.
 2. If Summertime is set, “S” will appear at the top right of the time setting screen during the Summertime period. (Refer to page 93.)

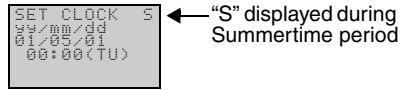

3-3 Creating Ladder Programs

Example Program

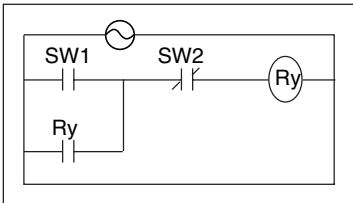

This section explains how to write ladder programs for LCD-type CPU Units, based on a simple circuit example.

Refer to the *ZEN-SOFT01-V3 ZEN Support Software Operation Manual (Z184)* for information on programming LED-type CPU Units.

3-3-1 I/O Wiring and Internal Operation

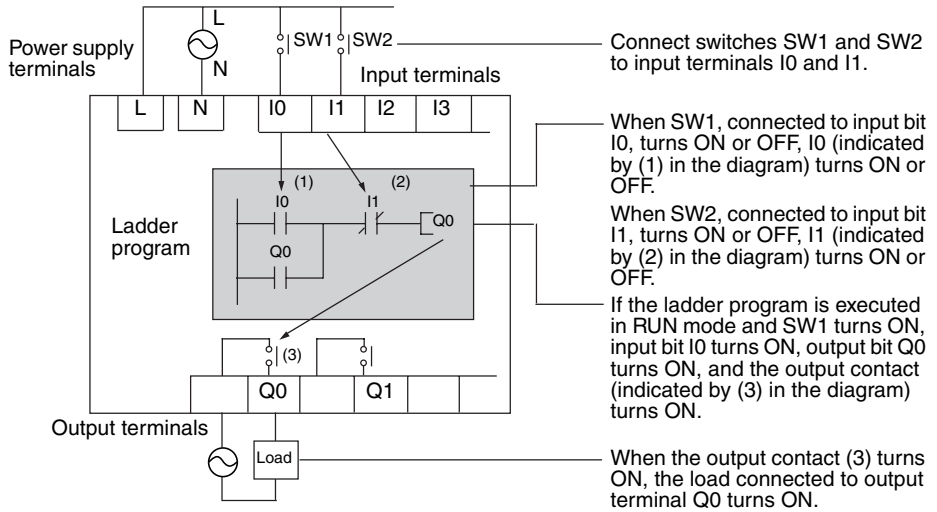

3-3-2 Clearing Programs

Clear the ladder program before starting to write a program. By performing the Delete Program operation, the ladder program will be completely cleared. The display language, date/time settings, and all other settings will not be initialized.

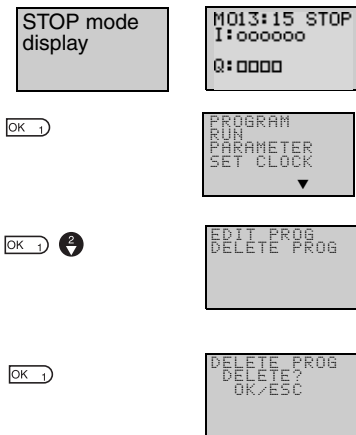

Press the **OK** Button to switch to the Menu Screen and select **PROGRAM**.

Select **DELETE PROG**.

If a password has been set, a Password Input Screen will be displayed. Input the password.

Press the **OK** Button to display a confirmation message.

OK 1



When the Delete Program operation has been completed, the display will return to the original screen.

3-3-3 Writing Ladder Programs

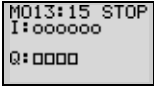
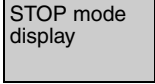

OK 1



Press the **OK** Button to switch to the Menu Screen and select **PROGRAM**.

OK 1

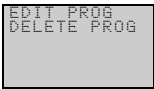

Select **EDIT PROGRAM**.

OK 1

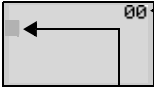

Indicates the line number in the ladder program at the cursor position (line 0 in this example.)

Cursor flashing in a reversed state.

Press the **OK** Button to switch to the Ladder Program Edit Screen.

Operations in the Ladder Program Edit Screen

Two lines of circuits can be displayed at one time on the Ladder Program Edit Screen.

- Up to 96 lines can be written.
- Up to 3 inputs and 1 output can be written per line.

- Example ladder diagram

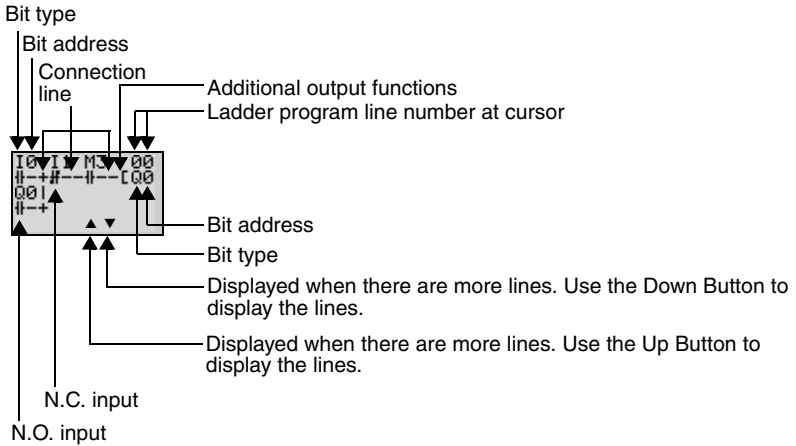

Positions for Writing Inputs, Outputs, and Connection Lines

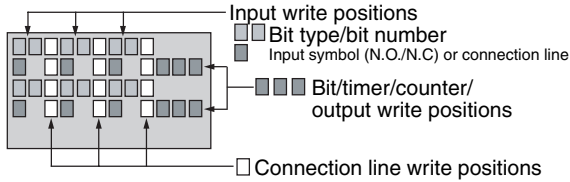

3-3-3-1 Writing an Input for I0



Press the **OK** Button to display the initial write setting (N.O input I0) and move the flashing cursor to the bit type I position. Use the **Up/Down** Buttons to select the bit type. Use the **Right** Button to move the flashing cursor to the 0 position and then use the **Up/Down** Buttons to select the bit address.



Press the **OK** Button twice to complete the write operation for input I0. The highlighted cursor will move the next input position.

3-3-3-2 Writing Serial Input I1

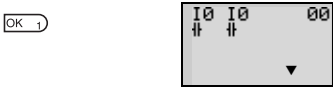

Press the **OK** Button to display the N.O. input and input I0 again.

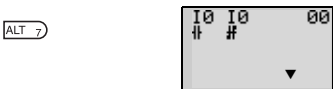

Press the **ALT** Button to switch to a N.C. input.

(Press the **ALT** Button again to switch back to a N.O. input.)



Use the **Right** Button to move the flashing cursor to the bit address position and use the **Up** Button to change the bit address to 1.

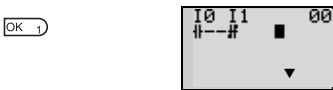

Press the **OK** Button to move the highlighted cursor to the next input position. A connection will automatically be created between input I0 and the next input.

Writing Inputs

Input Symbol Configuration

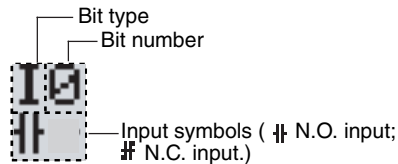

■ Memory Areas

Symbol	Name	Bit type and number
I	CPU Unit input bits	I0 to I5 (6 points) (See note 1.)
Q	CPU Unit output bits	Q0 to Q3 (4 points) (See note 2.)
X	Expansion I/O Unit input bits	X0 to Xb (12 points) (See note 3.)
Y	Expansion I/O Unit output bits	Y0 to Yb (12 points) (See note 3.)
M	Work bits	M0 to Mf (16 points)
H	Holding bits	H0 to Hf (16 points)
B	Button switches	B0 to B7 (8 points) (See note 4.)

- Note**
1. I0 to Ib (12 points) for CPU Units with 20 I/O points.
 2. Q0 to Q7 (8 points) for CPU Units with 20 I/O points.
 3. Can be used only when Expansion I/O Units are connected.
 4. Can be used only when LCD-type CPU Units are used.

■ Timers, Counters, and Analog Comparators

Symbol	Name	Bit type and number
T	Timers	T0 to Tf (16 timers)
#	Holding timers	#0 to #7 (8 timers)
@	Weekly timers	@0 to @f (16 timers) (See note 1.)
*	Calendar timers	*0 to *f (16 timers) (See note 1.)
C	Counters	C0 to Cf (16 counter)
A	Analog comparators	A0 to A3 (4 comparators) (See note 2.)
P	Comparators	P0 to Pf (16 comparators)

- Note**
1. Can be used only with CPU Units with calendar and clock functions.
 2. Can be used only with CPU Units with DC power supply.

Press the **ALT** Button to enable drawing a connection line. The left arrow cursor will flash.

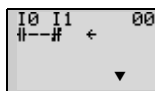

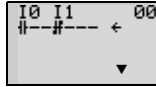

Press the **Right** Button to draw a connection line to the output.

Writing Outputs

Output Configuration

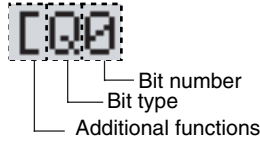

Memory Areas

Symbol	Name	Bit type and number
Q	CPU Unit output bits	Q0 to Q3 (4 outputs) (See note 1.)
Y	Expansion I/O Unit output bits	Y0 to Yb (12 outputs) (See note 2.)
M	Work bits	M0 to Mf (16 bits)
H	Holding bits	H0 to Hf (16 bits)

- Note**
1. Q0 to Q7 (8 points) for CPU Units with 20 I/O points.
 2. Can be used only when Expansion I/O Units are connected.

Additional Functions for Output Bits

Symbol	Name
[Normal operation
S	Set operation
R	Reset operation
A	Alternate operation

Additional Functions for Bit Outputs

[: Normal output	S: Set	R: Reset	A: Alternate
I0 #-----[Q0	I1 #-----SQ1	I2 #-----RQ2	I3 #-----AQ3
Q0 turns ON and OFF when execution condition I0 turns ON and OFF.	Q1 turns ON and stays ON when execution condition I1 turns ON once.	Q2 is forced OFF when execution condition I2 turns ON.	Q3 alternates between On and OFF each time execution condition I3 turns ON.

Timers, Holding Timers, Counters, and Display Output Configurations

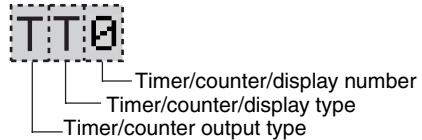

■ Timers, Counters, and Display Bits

Symbol	Name	Type and number	Output type
T	Timer	T0 to Tf (16 timers)	T: Trigger
#	Holding timer	#0 to #7 (8 timers)	R: Reset
C	Counter	C0 to Cf (16 counters)	C: Count D: Count direction R: Reset
D	Display bit	D0 to Df (16 bits) (See note 2.)	D

- Note**
1. These memory areas are smaller for the pre-V1 CPU Units.
 2. For LCD-type CPU Units only.

3-3-3-3 Writing an Output to Q0

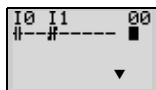

Press the **Right** Button again to draw a line to the output and move the highlighted cursor to the output write position.

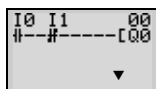

Press the **OK** Button to display the initial value for the output (normal output/Q0) and move the flashing cursor to the bit type Q position.

Use the **Up/Down** Buttons to select the bit type. Use the **Right/Left** Buttons to move the flashing cursor and use the **Up/Down** But-

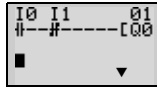

tons to select additional functions or select the bit address.

Press the **OK** Button twice to complete writing output Q0. The highlighted cursor will move to the input at the beginning of the next line.

3-3-3-4 Writing a Parallel Input for Q0

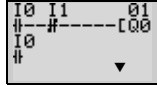

Press the **OK** Button to display input I0 and move the flashing cursor to the bit type I position.

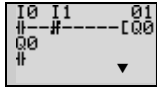

Press the **Up** Button to select **Q** (a CPU Unit output bit).

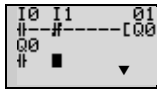

Press the **OK** Button twice to complete writing the parallel input for Q0. The highlighted cursor will move to the next input.

3-3-3-5 Drawing Connection Lines for OR Circuits

Drawing Connection Lines

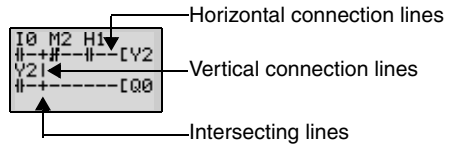

Press the **ALT** Button when the highlighted cursor is at the input write position to change the cursor to a left flashing arrow and enable connection lines to be drawn. Move the left arrow the position for drawing the connection line and press the **Up**, **Down**, **Left**, and **Right** Buttons to draw connection lines vertically and horizontally.

It will not be possible to draw connection lines when the beginning or end of the line has been reached or if the **OK** and **ESC** Buttons are pressed.

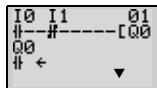

Press the **ALT** Button to enable drawing connection lines.

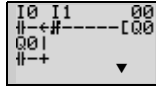

Press the **Up** Button to simultaneously draw a connection line both vertically and horizontally. The cross (+) indicates an intersection.

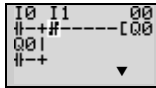

Press the **OK** Button to complete writing the connection line and change to a highlighted flashing cursor.



Press the **ESC** Button to complete the write operation.



Press the **ESC** Button again to return to the Menu Screen.

- Note**
1. Do not input a program where the connection lines double back on themselves. The program will not operate properly if such lines are drawn.
 2. Always press the ESC Button and return to the Menu Screen after creating a program. If you do not press the ESC Button and return to the Menu Screen before turning OFF the power, the program and settings will be deleted.

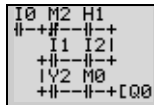

3. Do not use the same output bit address for more than one output from the program. The resulting operation may not be as expected.

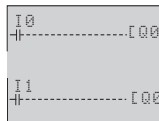

----- Here, the final status of Q0 will be controlled by I1, not by I0.

3-4 Confirming Ladder Program Operation

Always check the ladder program operation before using the ZEN.

- Note**
1. Before turning ON the power, check that the power supply, input circuits, and output circuits have been wired correctly.
 2. For systems with loads connected to the outputs that may cause serious injury or damage to equipment if operation is incorrect, remove the output wiring before performing trial operation.

3. Always ensure safety in the vicinity before turning ON the power or switching operating modes.

Procedure for Checking Operation

Checks Before Turning ON the Power

1. Check that the ZEN is mounted and wired correctly.
2. Check that the operation of the ZEN will not have a negative impact on the system. Check for any dangers.
3. Turn ON the power supply to the ZEN.
Switch to RUN mode while the ZEN is stopped.

Operation Checks

4. Turn each input ON and OFF and check that the program is operating correctly.
5. Adjust any problems.

Method for Checking Operation

LCD-type CPU Units	Check the operation by the flashing input and output displays on the Main Screen.
LED-type CPU Units	Connect the ZEN Support Software and check operation using the monitor function. Refer to the operation manual for the ZEN Support Software.

Checking Operation

Changing Operating Mode

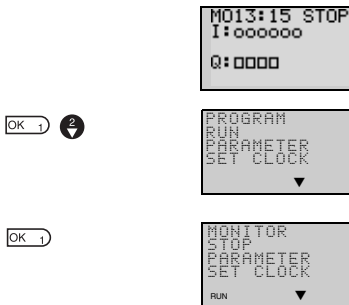

Press the **OK** Button to display the Menu Screen and press the **Down** Button to move the flashing cursor to RUN.

Press the **OK** Button to switch from STOP mode to RUN mode.

Checking Operations on Main Screen

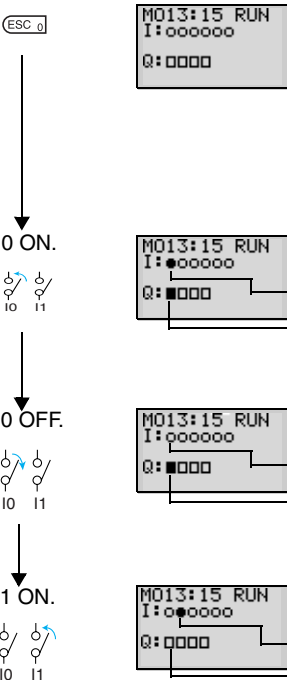

Press the **ESC** Button to switch to the Main Screen.

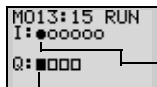
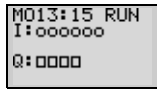

Q0 will turn ON when I0 turns ON.
 I0 ON.
 Q0 ON at the same time.

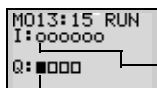

Q0 remains ON even if I0 turns OFF.
 I0 OFF.
 Q0 ON.

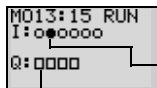

Q0 will turn OFF when I1 is turned ON.
 I1 ON.
 Q0 OFF.

Checking Operations Using Ladder Program Monitor

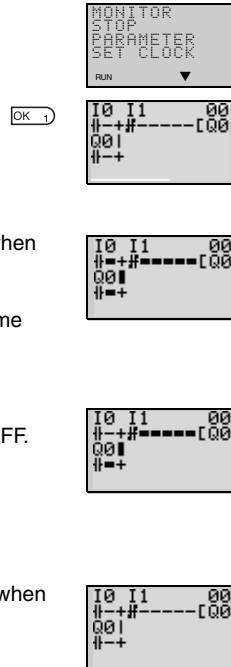

Select **Monitor** in RUN mode.

Press the **OK** Button to switch to the Ladder Program Monitoring Screen.

Q0 turns ON at the same time when I0 turns ON. When the bit is ON, the vertical and horizontal lines are thick.

3-5 Correcting Ladder Programs

3-5-1 Changing Inputs

Change contact Q0 to M1.

Move the highlighted cursor to the input to be changed.

```

I0 I1      01
|--+#-----[Q0
Q0|
|--+
  
```

OK →

2 / 5

4 → 5

```

I0 I1      01
|--+#-----[Q0
M0|
|--+
  
```

```

I0 I1      01
|--+#-----[Q0
M1|
|--+
  
```

OK →

Press the **OK** Button to change the highlighted cursor to a flashing cursor and move the flashing cursor to the bit type position.

Use the **Up/Down** Buttons to select **M**.

Press the **Right** Button to move the flashing cursor to the bit address position. Use the **Up/Down** Buttons to change the bit address from 0 to 1.

Press the **OK** Button to complete the setting change.

3-5-2 Changing Additional Bit Output Functions

Change the additional function for the input for Q0 to S (Set).

Move the highlighted cursor to the output to be changed.

```

I0 I1      00
|--+#-----[Q0
M1|
|--+
  
```

OK →

```

I0 I1      00
|--+#-----[Q0
M1|
|--+
  
```

```

I0 I1      00
|--+#-----[S0
M1|
|--+
  
```

OK → OK → OK →

Press the **OK** Button to change the highlighted cursor to a flashing cursor.

Press the **Left** Button to move the flashing cursor to the additional function position.

Press the **Up** Button twice to change the additional function from [to S.

Press the **OK** Button to complete the change.

3-5-3 Deleting Inputs, Outputs, and Connection Lines

Move the highlighted cursor to the position of the input, output, or connection line to be deleted and press the **DEL** Button.

Example: Deleting Serial Input M3

Move the highlighted cursor to the position of the input to be deleted.

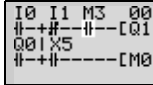

DEL 6

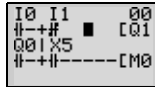

Press the **DEL** Button to delete the input and the related connecting lines at the same time.

Example: Deleting Vertical Connecting Lines

ALT 7

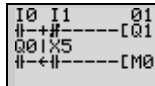

Move the highlighted cursor to the input position to the right of the vertical line to be deleted. Press the **ALT** Button to enable drawing connection lines. The highlighted cursor will change to a left arrow cursor.

DEL 6

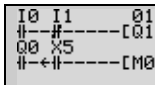

Press the **DEL** Button to delete the vertical connection line.

3-5-4 Inserting Lines

- To insert a blank line, move the highlighted cursor to the beginning of the line where the blank line is to be inserted and press the **ALT** Button.

Move the highlighted cursor to the beginning of the next line (the line that will be after the inserted line.)

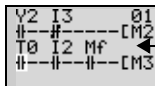

A circuit will be added here.

ALT 7

Blank line

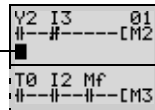

Press the **ALT** Button to insert one blank line.

- To add OR programming, inputs can be added between parallel inputs. Move the highlighted cursor to the beginning of the line where the input is to be inserted.

Move the highlighted cursor to the beginning of the next line (the line that will be after the inserted line.)

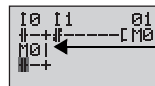

A input will be added here.

ALT 7

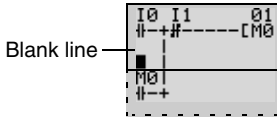

Press the **ALT** Button to reserve a 1-line space between the parallel inputs.

The vertical connection lines will be automatically extended.

Note A blank line cannot be inserted if an input or connection line is written in the last line (the 96th line).

3-5-5 Deleting Blank Lines

To delete a blank line, move the highlighted cursor to the input position at the beginning of the line to be deleted and press the **DEL** Button.

Move the highlighted cursor to the beginning of the line to be deleted.

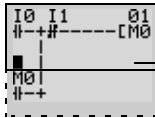

This line will be deleted.

DEL 8

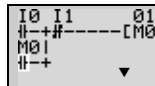

Press the **DEL** Button to delete one blank line. All following lines will move up one.

Note A line must be blank to be deleted, i.e., lines containing inputs and outputs cannot be deleted.

3-6 Using Timers (T) and Holding Timers (#)

The ZEN has 16 built-in timers and 8 built-in holding timers.

Timers	<p>The present value being timed will be reset when the timer switches from RUN mode to STOP mode or the power is turned OFF.</p> <p>There are four uses of the timer available, depending on the additional function selection.</p>
Holding timers	<p>The present value being timed is held even when the timer switches from RUN mode to STOP mode or the power is turned OFF. The time will continue when the trigger input turns ON again. The ON status of the timer bit is also held when the timer times out.</p> <p>Only ON-delay holding timers are supported.</p>

Timer Operation (T0 to Tf)

Timer type		Operation		Main applications
X	ON delay timer	Turns ON after a set interval after the trigger input has turned ON.		Time lag operations
■	OFF delay timer	Stays ON while the trigger input is ON and turns OFF after a set interval after the trigger input has turned OFF.		Useful for timing for lighting and ventilating fans
O	One-shot pulse timer	Remains ON for a set interval when the trigger input turns ON.		Useful for quantitative operation where operation is always required for the same period.
F	Flashing pulse timer	Turns ON and OFF repeatedly at set intervals while the trigger input is ON.		Useful as an alarm circuit for flashing emergency lighting or buzzers.

Note Only T0 to T7 (8 points) are supported by pre-V1 CPU Units.

Holding Timer Operation (#0 to #7)

Timer type		Operation		Main applications
X	ON delay timer only	Turns ON after a set interval after the trigger input has turned ON.		When operation is to be continued even during momentary power interruptions and longer power interruptions.

Note Only #0 to #3 (4 points) are supported by pre-V1 CPU Units.

3-6-1 Settings in the Ladder Program Edit Screen

Timer triggers, reset outputs, and timer inputs are drawn on the Ladder Program Edit Screen. Settings are made on the Parameter Settings Screen.

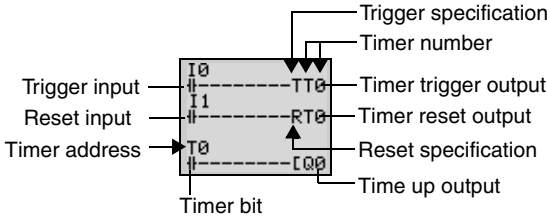

Timer address	Timers: T0 to Tf (16 timers)/ Holding Timers: #0 to #7 (8 timers)	
Trigger input	T (TRG)	Controls the timer trigger output. Triggers the timer when the trigger input turns ON.
Reset input	R (RES)	Controls the timer reset output. When the reset input turns ON, the present value is reset to 0 and the timer bit turns OFF. Trigger inputs are not accepted while the reset input is ON.
Timer bit	Turns ON according to the timer type.	

Note Only T0 to T7 (8 points) and #0 to #3 (4 points) are supported by pre-V1 CPU Units.

3-6-2 Settings in the Parameter Settings Screen

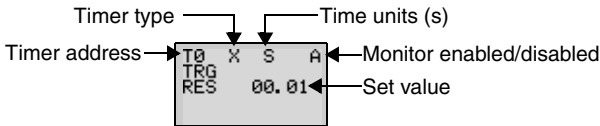

Timer Types

X	ON delay
■	OFF delay
O	One-shot pulse
F	Flashing pulse

Time Units and Settings

S	00.01 to 99.99 s (in 0.01-s units)	Error: 0 to -10 ms
M:S	00 min 01 s to 99 min 59 s (in minutes and seconds)	Error: 0 to -1 s
H:M	00 h 01 m to 99 h 59 m (in hours and minutes)	Error: 0 to -1 min

Monitor Enabled or Disabled

A	Operating parameters can be monitored and settings changed.
D	Operating parameters cannot be monitored nor settings changed.

3-6-3 Parameter Monitor Screen Display

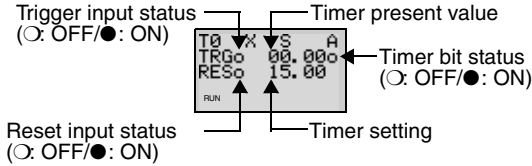

3-7 Using Counters (C)

Up to 16 counters can be used in incremental or decremental mode. The present value for counters and the status of counter bits (ON/OFF) are held even when the operating mode is changed or there is a power interruption.

Operation

Counter bits turn ON when the count value (present value) exceeds the setting (present value \geq set value). The count returns to 0 and the bits turns OFF when the reset input turns ON. Count inputs are not accepted while the reset input is ON.

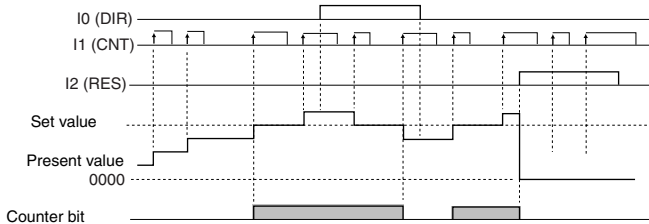

3-7-1 Settings in the Ladder Program Edit Screen

Outputs for the counter input, counter direction, and counter reset are written in the Ladder Program Edit Screen. Counter input conditions can also be written. Settings are made in the Parameter Settings Screen.

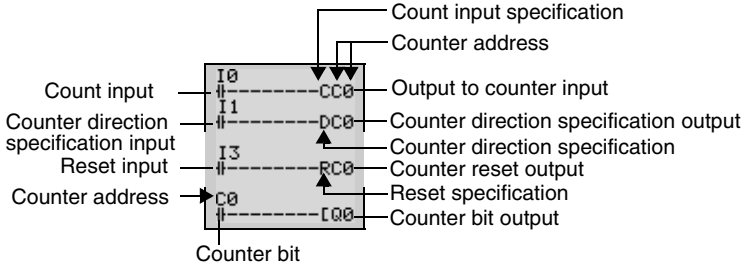

Counter address	C0 to Cf (16 points)	
Counter input	C (CNT)	Increments (or decrements) each time the count input turns ON.
Counter direction specification input	D (DIR)	Switches between incremental and decremental counting. OFF: Incremental ON: Decremental
Reset input	R (RES)	When the reset input turns ON, the present value returns to 0 and the counter bit turns OFF. Count inputs are not accepted while the reset input is ON.
Count input	Turns ON when the counter has counted out (PV ≥ SV)	

Note Only C0 to C7 (8 points) are supported by pre-V1 CPU Units.

3-7-2 Settings in the Parameter Settings Screen

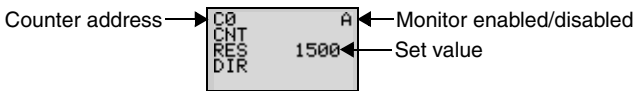

Set value	0001 to 9999 (4 decimal digits) times	
Monitor enabled/disabled	A	Operating parameters can be monitored and settings changed.
	D	Operating parameters cannot be monitored or settings changed.

3-7-3 Parameter Monitor Screen Display

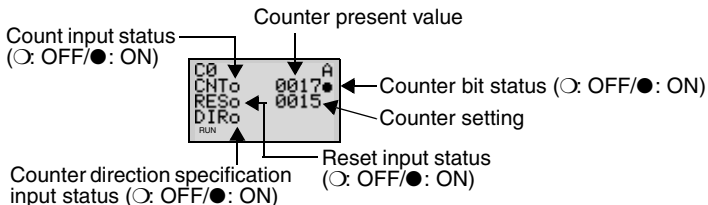

- Note**
- To reset the counter present value and counter bit status (ON/OFF) when at power interruptions or when the operating mode is changed, create a counter reset circuit when you first execute the program. An example is shown below.

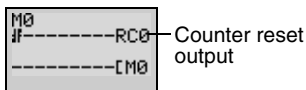

- If the counter input and counter direction are input simultaneously, place the output for the counter direction before the output for the counter input in the program.

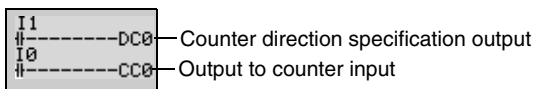

3-8 Using Weekly Timers (@)

Weekly timers turn ON between the specified start and stop times on the specified days. Weekly timers have 16 points (@0 to @f.)

Operation

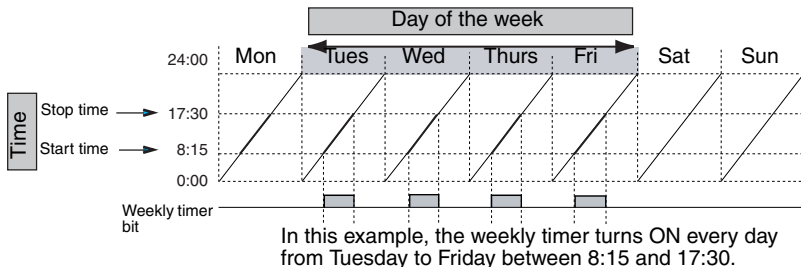

3-8-1 Settings in the Ladder Program Edit Screen

Weekly timer inputs are written in the Ladder Program Edit Screen. Settings are made in the Parameter Settings Screen.

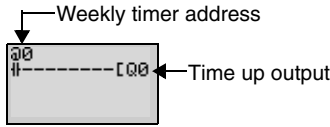

Weekly timer addresses	@0 to @f (16 timers)
------------------------	----------------------

Note Only @0 to @7 (8 points) are supported by pre-V1 CPU Units.

3-8-2 Settings in the Parameter Settings Screen

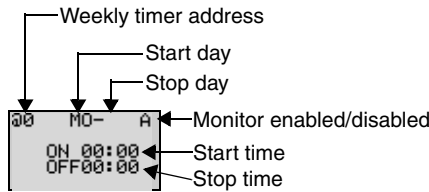

Note When the flashing cursor is on the start day, press the **Right** Button and then the **Up/Down** Buttons to set the stop day. If the stop day is not set, the timer will operate according to the set time only.

Day	Start day	Sun/Mon/Tues/Wed/Thurs/Fri/Sat
	Stop day	Sun/Mon/Tues/Wed/Thurs/Fri/Sat/None
Time	Start time	00:00 to 23:59
	Stop time	00:00 to 23:59
Monitor enabled/disabled	A	Operating parameters can be monitored and settings changed.
	D	Operating parameters cannot be monitored or settings changed.

Relationship between Start and Stop Days and Times

Setting and operation	Setting example	Operation
Start and stop day	When start day is before stop day	MO - FR Operates Monday to Friday every week.
	When start day is after stop day	FR - MO Operates every Friday through to the following Monday.
	When start and stop days are the same	SU - SU Operates regardless of the day of the week.
	When stop day not set	SU - Operates every Sunday only.
Start and stop time	When start time is before stop time	ON: 08:00 OFF: 17:00 Operates 8:00 to 17:00 every day.
	When start time is after stop time	ON: 21:00 OFF: 06:00 Operates 21:00 to 6:00 the next day.
	When start and stop times are the same	ON: 13:00 OFF: 13:00 Operates regardless of the time.

3-8-3 Parameter Monitor Screen Display

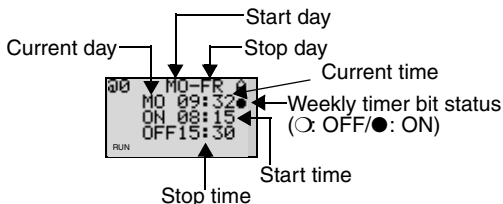

3-9 Using Calendar Timers (*)

Calendar timers turn ON between specified dates. There are 16 calendar timers (*0 to *f).

Operation

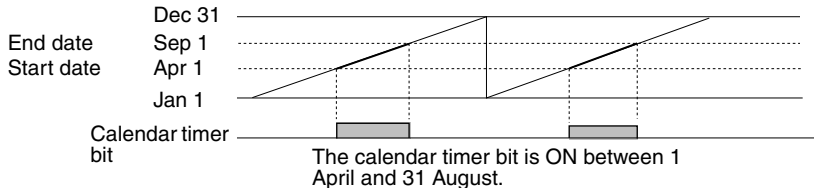

3-9-1 Settings in the Ladder Program Edit Screen

Calendar timer inputs are written in the Ladder Program Edit Screen. Settings are made in the Parameter Settings Screen.

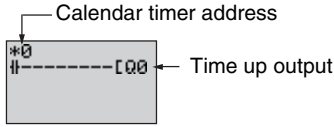

Calendar timer address	*0 to *f (16 timers)
------------------------	----------------------

Note Only *0 to *7 (8 points) are supported by pre-V1 CPU Units.

3-9-2 Settings in the Parameter Settings Screen

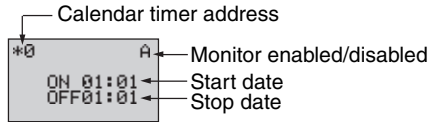

Start date	Jan 1 to Dec 31	
Stop date (See note.)	Jan 1 to Dec 31	
Monitor enabled/ disabled	A	Operating parameters can be monitored and settings changed.
	D	Operating parameters cannot be monitored or settings changed.

Relationship between Start and Stop Dates

Setting and operation		Setting example	Operation
Start and stop date settings and operation	When start date is before stop date	ON: 04/01 OFF: 09/01	Operates between 1 April and 31 August. (See note.)
	When start date is after stop date	ON: 12/26 OFF: 01/07	Operates between 26 December and 6 January the following year.
	When start and stop dates are the same.	ON: 07/26 OFF: 07/26	Operates regardless of the date.

Note To stop operation on August 31, set the stop date to the following day (September 1).

3-9-3 Parameter Monitor Screen Display

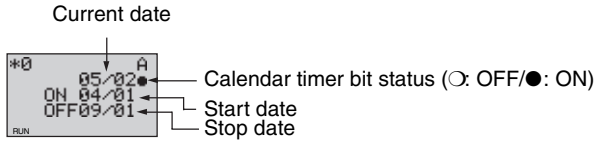

3-10 Analog Inputs (Analog Comparators (A))

Two analog voltage inputs between 0 and 10 V can be incorporated into the CPU Units with a DC power supply. I4 and I5 for CPU Units with 10 I/O points and Ia and Ib for CPU Units with 20 I/O points can be used as analog voltage inputs.

The analog input signal is converted to BCD (00.0 to 10.0). The results can be used with one of the comparators A0 to A3, and the 4 comparison outputs can be used as input conditions in the program.

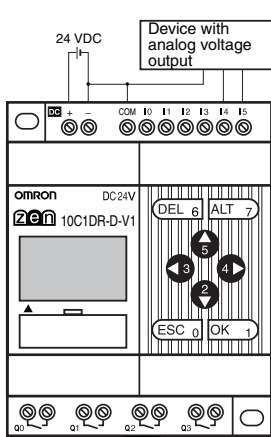

(DC power supply type)
Analog input 1: I4
Analog input 2: I5

Analog signal input:
0.0 to 10.0 V

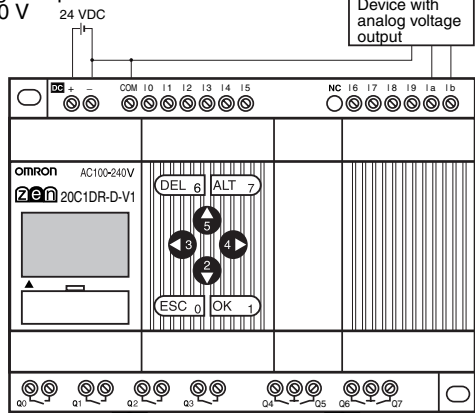

Analog input: Ia
Analog input: Ib

DC power supply type

Note Connect the negative side to COM for V1 CPU Units. The analog input circuit may be destroyed if the positive side is connected to COM.

Operation

- Example 1
(When comparison shows analog input 1 \geq 5.2 V)

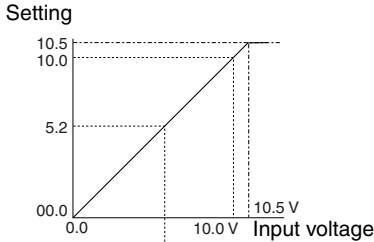

Analog comparator bit

The analog comparator bit turns ON when the analog input voltage reaches is 5.2 V or higher.

- Example 2
(When comparison shows analog input 1 is \leq analog input 2)

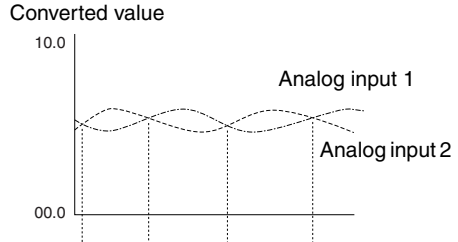

Analog comparator bit

The analog comparator bit turns ON when the analog input 2 voltage is higher than the analog input 1 voltage.

Note Do not make negative signal inputs to analog inputs. If negative signals are made, the internal elements may be damaged.

3-10-1 Settings in the Ladder Program Edit Screen

The analog comparator input is written in the Ladder Program Edit Screen. Settings are made in the Parameter Settings Screen.

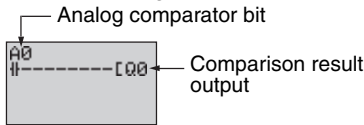

Analog comparator address	A0 to A3 (4 comparators)
---------------------------	--------------------------

3-10-2 Settings in the Parameter Settings Screen

- Comparing Analog Inputs and Constants
(When $I4 (Ia) \geq \text{constant}$)

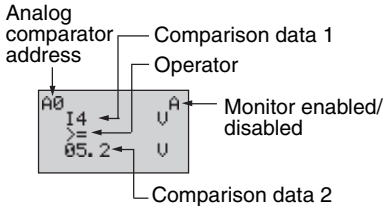

- Comparing Analog Inputs
(When $I4 (Ia) \leq I5 (Ib)$)

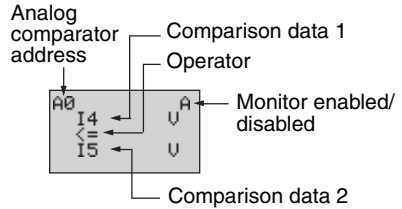

Comparison data 1 determines the comparison pattern. When comparing to a constant, the constant is set for comparison data 2 next. The operator is specified last.

Analog comparator address	A0 to A3 (4 comparators)	
Comparison data	1	I4: Analog input 1 (I4/Ia) I5: Analog input 2 (I5/Ib) Comparison Patterns • Size comparison between I4/Ia and I5/Ib.
	2	I5: Analog input 2 (I5/Ib) Constant: 00.0 to 10.5 • Size comparison between I4/Ia and constant. • Size comparison between I5/Ib and constant.
Operator	>=: Analog comparator bit turns ON when comparison data 1 \geq comparison data 2.	
	<=: Analog comparator bit turns ON when comparison data 1 \leq comparison data 2.	
Monitor enabled/disabled	A	Operating parameters can be monitored and settings changed.
	D	Operating parameters cannot be monitored or settings changed.

Note For CPU Units with 20 I/O points, Ia is analog input 1 and Ib is analog input 2.

3-10-3 Parameter Monitor Screen Display

- Comparing Analog Inputs and Constants
(When $I4 (Ia) \geq \text{constant}$)

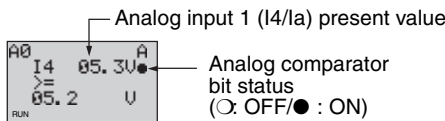

- Comparing Analog Inputs
(When $I4 (Ia) \leq I5 (Ib)$)

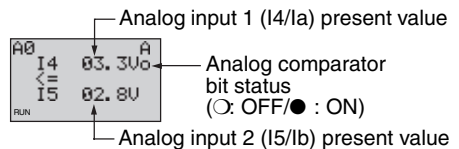

3-11 Comparing Timer/Counter Present Values Using Comparators (P)

Timer (T), holding timer (#), and counter (C) present values can be compared. The present values of the same type of timer or counter can be compared, or they can be compared to constants.

Operation

- Example 1
(When comparison setting is holding timer #0 \geq 12 min 34 s)

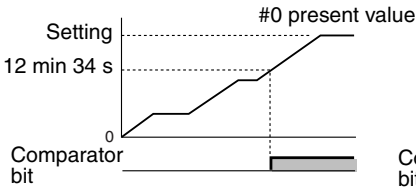

- Example 2
(When comparison setting is counter 1 (C1) \leq counter 2 (C2))

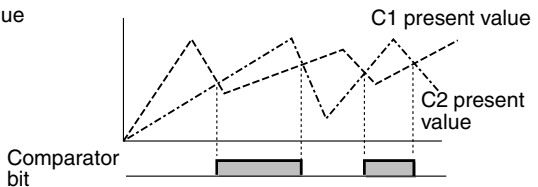

3-11-1 Settings in the Ladder Program Edit Screen

Comparator inputs are written in the Ladder Program Edit Screen. Settings are made in the Parameter Settings Screen.

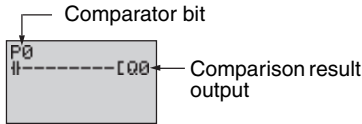

Comparator addresses	P0 to Pf (16 points)
----------------------	----------------------

3-11-2 Settings in the Parameter Settings Screen

- Comparing Holding Timers and Constants
(When Holding Timer #0 ≥ 12 min 34 s)
- Comparing Counters
(When counter 1 (C1) ≤ counter 2 (C2))

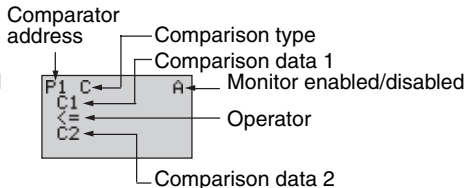

Comparison type		T: Timer #: Holding timer C: Counter	
Comparison data	1	T: T0 to Tf Timers 0 to f #: #0 to #7 Holding timers 0 to 7 C: C0 to Cf Counters 0 to f	* Size comparison between T and T or T and constant. * Size comparison between # and # or # and constant.
	2	T: T0 to Tf Timers 0 to f #: #0 to #7 Holding timers 0 to 7 C: C0 to Cf Counters 0 to f Constant: 00.00 to 99.99 when comparison type is T/# 0000 to 9999 when comparison type is C	* Size comparison between C and C or C and constant.
Operator		>=: Timer/counter comparator bit turns ON when comparison data 1 ≥ comparison data 2. <=: Timer/counter comparator bit turns ON when comparison data 1 ≤ comparison data 2.	
Monitor enabled/disabled	A	Operating parameters can be monitored and settings changed.	
	D	Operating parameters cannot be monitored or settings changed.	

Note Only T0 to T7, #0 to #3, and C0 to C7 are supported by pre-V1 CPU Units.

3-11-3 Parameter Monitor Screen Display

- Comparing Holding Timers and Constants
(When Holding Timer #0 ≥ 12 min 34 s)
- Comparing Counters
(When counter 1 (C1) ≤ counter 2 (C2))

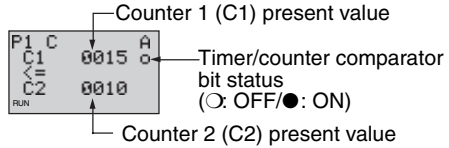
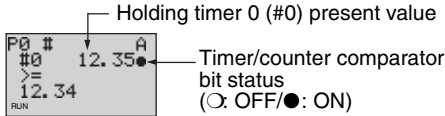

Note

1. Press the **ALT** Button to switch between comparison data 2 timer/counter address and constants.
2. The time unit is determined as follows when timers or holding timers have been specified under comparison type:
 - a) When a constant has been set to as comparison data 2, the time unit is automatically aligned with the unit for comparison data 1 timers or holding timers.
 - b) The time units are automatically aligned when the units are different for comparison data 1 and 2 timers.

3-12 Displaying Messages (Display Bits (D))

A user-set message, the time, a timer/counter present value, or an analog conversion value can be displayed on the LCD screen. If multiple display functions are used, multiple data can be displayed on the same screen.

- Operation Example 1

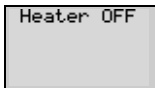

Monitors the system operation status.

Settings Details

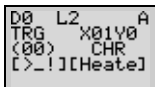

- Operation Example 2

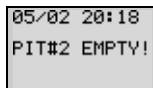

Displays the date and time that the system error occurred.

Settings Details

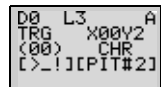
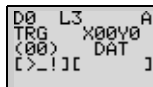

⚠ Caution The ZEN ladder program is executed in order of ascending line numbers. If more than one item is displayed on the same line, the display function that was executed last will be shown on the display and previous ones will be deleted.

Caution The display clear function will erase all displays from the specified digit on (i.e., the display will be blank). If the display clear function is executed for the same line after another display function, the display will still be erased from the specified digit on.

3-12-1 Settings in the Ladder Program Edit Screen

The display functions are written in the Ladder Program Edit Screen. Settings are made in the Parameter Settings Screen.

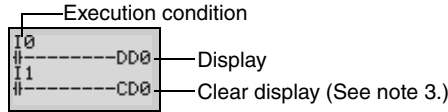

Display address	D0 to Df (16 points)
-----------------	----------------------

Note Only D0 to D7 (8 points) are supported by pre-V1 CPU Units.

3-12-2 Settings in the Parameter Settings Screen

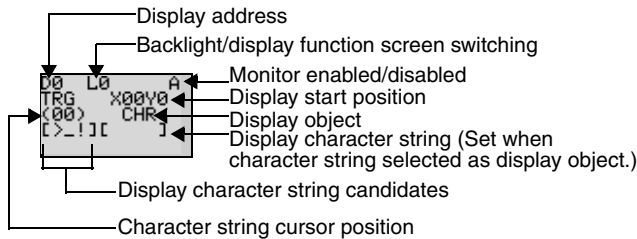

Backlight/display function screen switching	L0	No backlight; No switching to display function screen (See note 1.)
	L1	Backlight; No switching to display function screen (See note 1.)
	L2	No backlight; Switching to display function screen (See note 2.)
	L3	Backlight; Switching to display function screen (See note 2.)
Display start position	X (digit): 00 to 11	
	Y (line): 0 to 3	

Display object	CHR	Characters (12 max.: Alphanumeric characters and symbols)
	DAT	Month/day (5 digits: □□/□□)
	DAT1 (See note 3.)	Day/month (5 digits: □□/□□)
	CLK	Hour/minutes (5 digits: □□:□□)
	I4, I5 (Ia, Ib)	Analog conversion (4digits: □□.□)
	T0 to Tf	Timer present value (5 digits: □□.□□)
	#0 to #7	Holding timer present value (5 digits: □□.□□)
	C0 to Cf	Counter present value (4 digits: □□□□)
Monitor enabled/ disabled	A	Operating parameters can be monitored.
	D	Operating parameters cannot be monitored.

- Note**
1. When L0 or L1 are selected to disable the display function screen, the display function screen will not be displayed automatically. Use operation buttons to move to the display function screen.
 2. When L2 or L 3 are selected (switching to display function screen), the ZEN switches to the display function screen if the display function is enabled and the specified data is displayed. The Main Screen will no longer be displayed. To display the Main Screen, change the CPU Unit to STOP mode.
 3. The clear display (-CD□) function and DAT1 (day/month display) display function can be used only by CPU Units of system software version 1.10 or later. For details on the CPU Unit version, select *Other/System information*. (Refer to page 94.)
ZEN Support Software of Ver. 2.00 or later supports these functions. If ladder programs including these functions are uploaded using older-version Support Software, they cannot be read correctly.

Settings when Character (CHR) Selected

Move the highlighted cursor to the display character string column.

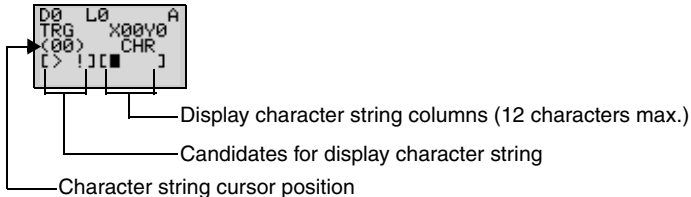

OK 1

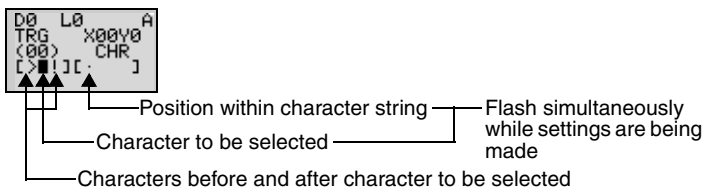

6 (2)

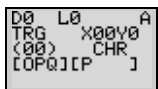

Use the **Up/Down** Buttons to scroll through the candidate characters.
 Alternates display of the candidate character and the position mark. Candidate is highlighted and flashing.

4

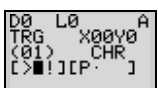

Use the **Right** Button to move the character string position to the right. Use the **Left** Button to move the character string to the left.

6 (2)

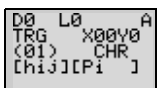

OK 1

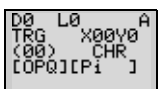
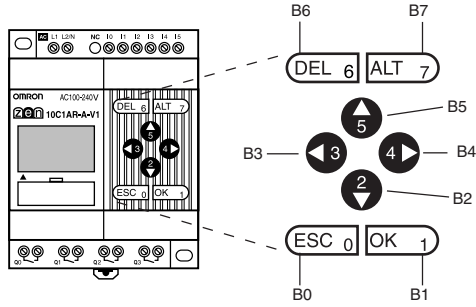









Table of Display Characters

	!	"	#	\$	%	&	'	()	*	+	,	-	.	/		
0	1	2	3	4	5	6	7	8	9	:	:	<	=	>	?		
a	b	c	d	e	f	g	h	i	j	k	l	m	n	o			
p	q	r	s	t	u	v	w	x	y	z	[]	^	_			
\	~	`	a	b	c	d	e	f	g	h	i	j	k	l	m	n	o
p	q	r	s	t	u	v	w	x	y	z	<	[]				

3-13 Using Button Switches (B)

For LCD-type CPU Units, the operation buttons are used to perform operations for input bits. They are useful when checking program operations or forcefully resetting holding timers or counters.



Button switch address	Operation button
B0	ESC 
B1	OK 
B2	Down 
B3	Left 
B4	Right 
B5	Up 
B6	DEL 
B7	ALT 

Using Button Switches

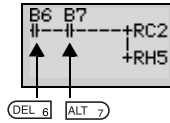

- The buttons can also be used as “hidden keys” for software resets of counters or holding bit present values.

Press the **DEL+ALT** Buttons simultaneously during operation to reset the counter C2 present value to 0 and the holding bit H5 to OFF.

- Note**
1. The buttons can be used as operation buttons for each screen. When using the buttons as buttons switches, make your selections based on the screen status.
 2. The operation buttons can be used for ZEN operations, such as menu selections, regardless of whether or not button switches (B) are being used. When a button is pressed for ZEN operations, the button switch (B) also turns ON. Make sure that the system will not be affected by this before pressing buttons.

SECTION 4

Special Functions

This section describes how to protect ladder programs, stabilize inputs, make LCD screen adjustments, and make summer time settings.

4-1	Protecting Programs	88
4-1-1	Setting a Password	89
4-1-2	Deleting Registered Passwords	89
4-2	Stabilizing Input Operations	90
4-3	Changing Backlight Automatic Cutout Time	92
4-4	Adjusting LCD Screen Contrast	93
4-5	Setting Summertime	93
4-6	Reading System Information	94

4-1 Protecting Programs

The ZEN has a password function to prevent incorrect manipulation of ladder programs or settings data by other operators.

Note Always record your password for future reference when using the password function. You will no longer be able to operate the ZEN if you forget your password.

- The password setting range is 0000 to 9999 (4 decimal digits).
- You will no longer be able to perform the following operations if the password is not input correctly.

Edit ladder programs

Clearing programs (V1 CPU Units only)

Monitor ladder programs

Change or delete the password

Set the input filter

Set the node address

- When any of these functions is selected from the menu, the Password Input Screen will be displayed. If the password is input correctly, the display will move to the next screen for the selected function. However, if the password is input incorrectly, the next screen will not be displayed.

4-1-1 Setting a Password

Select **Other**.



Select **Password**.



Press the **OK** Button to change to a flashing cursor and enable a password to be set.

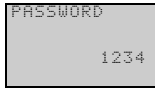

Set the password.

Use the **Left** and **Right** Buttons to move to the digit to be changed.

Use the **Up/Down** Buttons to input a numeral between 0 and 9.

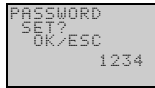

Press the **OK** Button. A confirmation message will be displayed.



The  icon will appear at the bottom right of the screen when a password has been registered.

Note The display will automatically change to the Waiting for Password Input Screen when making settings that require a password to be input. Use the same method as outlined above to input the registered password.

4-1-2 Deleting Registered Passwords

Select **Other/Password**.

Press the **OK** Button to change to a flashing cursor and to enable password setting.

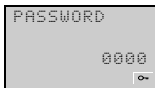

Input the registered password.

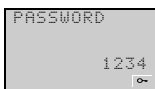

Use the **Left** and **Right** Buttons to move to the digit to be changed.

Use the **Up/Down** Buttons to input a numeral between 0 and 9.

OK 1

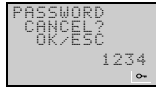

Press the **OK** Button to display a message asking whether or not to delete the set password.

If the input password does not match the registered password, the display will return to the original screen.

If the password was correct, press the **OK** Button to delete the password.

OK 1



← The  icon will disappear when the password is deleted.

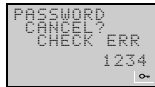

If the input password does not match the registered password, a **CHECK ERR** message will be displayed. Re-enter the password correctly.

4-2 Stabilizing Input Operations

If external input contacts chatter, ZEN operation may become unstable. Set an input filter to stabilize operation. Input filters can be set separately for the CPU Unit and each Expansion I/O Unit.

Operation (Example: DC Input Circuits)

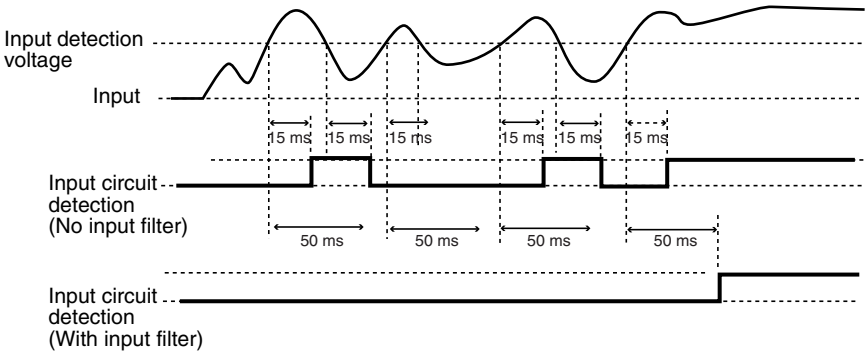

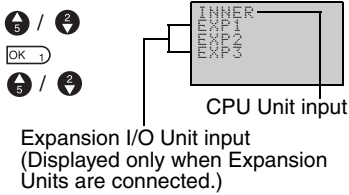

Press the **OK** Button to display the Input Filter Settings Menu.

Use the **Up** and **Down** Buttons to select from the menu the Unit for which the input filter is to be set.

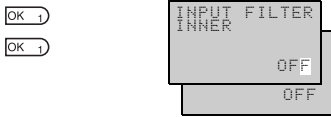

Press the **OK** Button twice to change to a flashing cursor and enable input filter settings to be made.



Use the **Up/Down** Buttons to switch between ON and OFF.



Press the **OK** Button to confirm the setting.
Press the **OK** Button again to complete the setting.

Note 1. The filter timers outlined in the following table are set for each input type when the input filter function is set.

Input specifications		Input filter not used	Input filter used
AC input	100 VAC	50 ms	70 ms
	240 VAC	100 ms	120 ms
DC input		15 ms	50 ms

2. The input filter settings are read when the ZEN starts operation.

4-3 Changing Backlight Automatic Cutout Time

The LCD backlight automatically turns ON when button operations are performed. It then turns OFF automatically 2 minutes after button operations stop. The default backlight cutout setting of 2 minutes can be changed to 10 or 30 minutes or the backlight can be set to remain ON continuously.

Button operation	Operation starts	Operation stops	
Display function (when L1 or L3 is set)	OFF → ON - - DDO	ON → OFF - - DDO	Cutout time ←—————→
Backlight status	Lit.	Remains lit.		Remains lit.

Select
**Other/
Backlight.**



Press the **OK** Button to display the current backlight cutout setting.

Press the **OK** Button again to change to a flashing cursor and enable backlight cutout time settings to be made.

Use the **Up** and **Down** Buttons to set the cut-out time.

- ON (Continuously ON)
- 30 min
- 10 min
- 2 min

Press the **OK** Button to confirm the setting.

Press the **OK** Button again to complete the setting.

Note The backlight cutout time is used not only to determine if and when the backlight turns OFF after button operations have stopped. If backlight has been specified to turn ON with the display function, the same setting is used to determine if and when the backlight turns OFF once the execution of the display function has been completed.

4-4 Adjusting LCD Screen Contrast

Use the following procedure to adjust the contrast of the LCD (liquid crystal display) screen if the screen is too dark or too light and difficult to read.

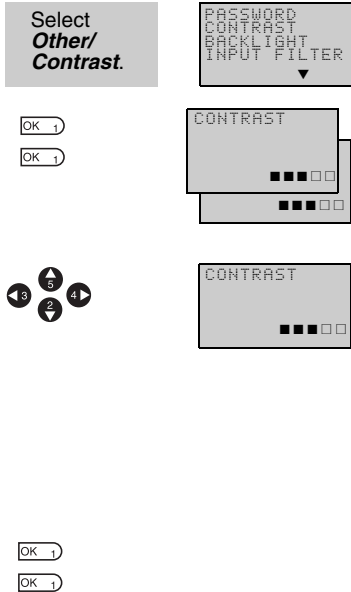

Press the **OK** Button to display the current setting in a 5-level bar graph.

Press the **OK** Button again to change to a flashing cursor and enable the contrast to be adjusted.

Use the **Up/Down** and **Left/Right** Buttons to adjust the contrast.

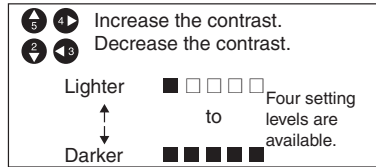

Press the **OK** Button to confirm the setting.

Press the **OK** Button again to complete the setting.

4-5 Setting Summertime

Set the Summertime function when using the ZEN in countries that use Summertime.

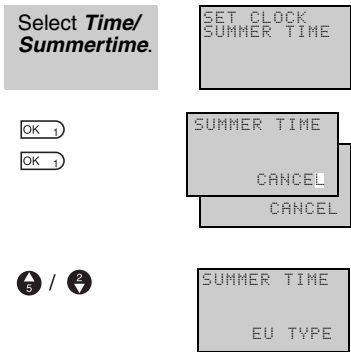

Press the **OK** Button to display the current settings.

Press the **OK** Button again to change to a flashing cursor and enable Summertime settings to be made.

Use the **Up** and **Down** Buttons to make the setting.

- ⌚ US Type (for Summertime in American countries)
- ↓ EU Type (for Summertime in European countries)
- ↑ Manual (for manual settings)
- ⌚ Cancel (for no Summertime)

OK ↵

OK ↵

Press the **OK** Button to confirm the setting.
Press the **OK** Button again to complete the setting.

Cancel	Summertime settings are not made. Any Summertime settings that have been made will be deleted.	
Manual	Moves the clock forward 1 hour.	
EU Type	Summertime period: 2:00 a.m last Sunday in March to 2:00 a.m. last Sunday in October	Once the start time (2:00 a.m.) has been reached, the clock is moved forward 1 hour to 3:00 a.m. When the stop time (2:00 a.m) has been reached, the clock is moved backwards 1 hour to 1:00 a.m.
US Type	Summertime period: 2:00 a.m first Sunday in April to 2:00 a.m. last Sunday in October	

Note When Summertime has been set, an “S” will appear at the top right of the Time Settings Screen during the Summertime period.



"S" displayed during the Summertime period.

4-6 Reading System Information

The software version of the CPU Unit, the number of CPU Unit and Expansion I/O Unit I/O points, and other information can be read.

Select **Other/ System information.**

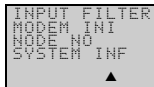

OK ↵

⬆ / ⬇

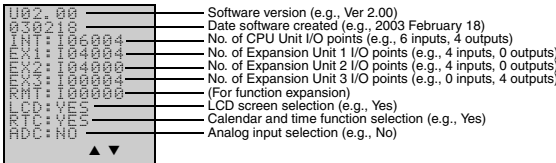

SECTION 5

Optional Products

This section describes how to mount Battery Units, use Memory Cassettes, and how to connect the ZEN Support Software.

5-1	Mounting Battery Units	96
5-2	Using Memory Cassettes	97
5-3	Connecting the ZEN Support Software	99

5-1 Mounting Battery Units

Ladder programs and all settings are saved to the CPU Unit EEPROM but calendar, clock, and holding timer bits and holding timer/counter present values are held by the capacitor. Therefore, if the power supply is interrupted for an extended time (2 days or more at 25°C), that data is reset. Mount a Battery Set (optional) for systems where the power supply may be interrupted for long periods.

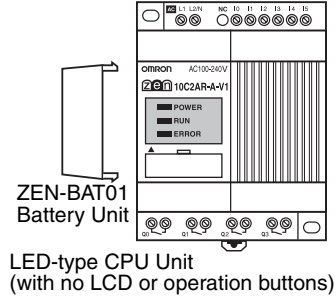
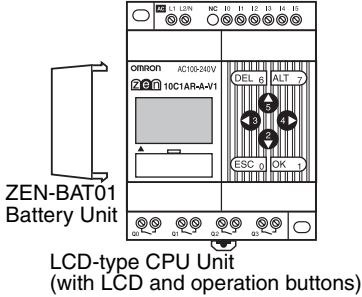

Mounting Method

- 1,2,3...**
1. Tilt the Battery Unit to the side and insert the claw at the bottom of the Battery Unit into the mounting hole on the left side of the CPU Unit.

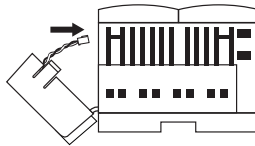

2. Connect the Battery Unit cord to the CPU Unit connector.

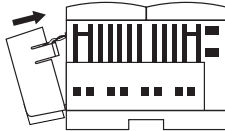

3. Push the claw at the top of the Battery Unit into the CPU Unit.

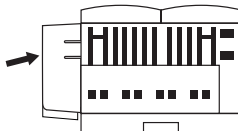

- Note**
1. Turn OFF the power supply to the CPU Unit before mounting the Battery Unit.
 2. Do not short the positive and negative terminals or recharge, dismantle, overheat, or incinerate the Battery Unit.
 3. Do not drop the Battery Unit. The battery may leak or other damage occur if the Battery Unit is dropped.
 4. The Battery Unit has a life of 10 years min.

5-2 Using Memory Cassettes

Optional Memory Cassettes can be used to save the ladder program and settings and to copy programs and settings to other CPU Units.

Mounting Memory Cassettes

- 1,2,3...**
1. Remove the connector cover on the front of the ZEN.

LCD-type CPU Unit
(with LCD and
operation buttons)

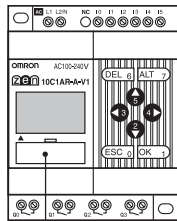

LED-type CPU Unit
(no LCD/operation
buttons)

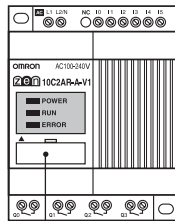

Connector cover

(Use a flat-blade screwdriver if the cover is difficult to remove.)

2. Mount the Memory Cassette.

ZEN-ME01
Memory Cassette

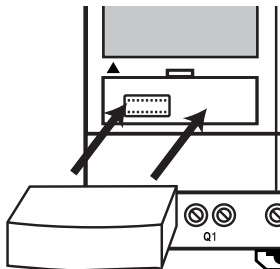

Note Always turn OFF the power supply to the CPU Unit before removing or mounting Memory Cassettes.

Transferring Programs

Select **Program** in STOP mode.

```
PROGRAM
RUN
PARAMETER
SET CLOCK
▼
```

OK →



```
EDIT PROG
DELETE PROG
CASSETTE
```

Select **Memory Cassette**.

OK →



```
LOAD
ERASE
```

The Operation Menu for Memory Cassettes will be displayed.

Use the **Up/Down** Buttons to move the flashing cursor and press the **OK** Button to select an operation.

Menu	Operation	LCD type	LED type
Save	Saves CPU Unit programs to the Memory Cassette. Existing programs on the Memory Cassette will be overwritten.	Supported	Not supported
Load	Transfers programs from the Memory Cassette to the CPU Unit.	Supported	Automatically transferred at power-ON.
Erase	Initializes the Memory Cassette (i.e. deletes programs).	Supported	Not supported

Note

1. The transferable program includes the ladder programs, parameters, and all settings data. The present values for the timers, holding timers, counters, and holding bits cannot be transferred.
2. Only error-free programs can be transferred. The program will not be transferred if there is any illegal data in the program.
3. The Memory Cassette can be written to up to 100,000 times.

Mounting Memory Cassettes to LED-type CPU Units

When a Memory Cassette with an error-free program is mounted to an LED-type CPU Unit, the program on the Memory Cassette is automatically transferred to the CPU Unit. An existing program in the CPU Unit will be overwritten.

5-3 Connecting the ZEN Support Software

The ZEN Support Software can be used for programming and monitoring. Refer to the *ZEN-SOFT01-V3 ZEN Support Software Operation Manual (Z184)* for information on the functions and operation of the ZEN Support Software.

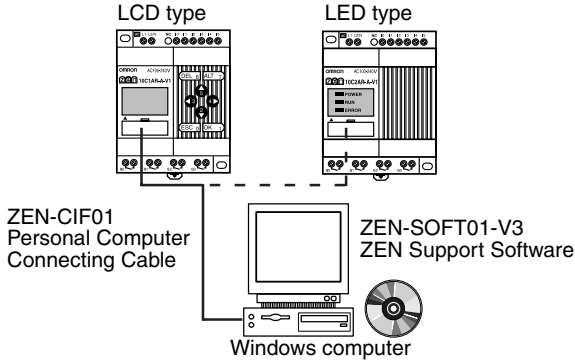

Computer Specifications

Item	Conditions
Operating system	Windows 95, 98, ME, 2000, XP, NT4.0 Service Pack 3
CPU	Pentium 133 MHz or greater (Pentium 200 MHz or greater recommended)
Memory	64 Mbytes min.
HD capacity	40 Mbytes free disk space min.
CD-ROM drive	Required.
Communications	1 serial (COM) port
Keyboard and mouse	Required
Monitor	800 x 600 dots (SVGA) min.; 256 colors min.

Setting Node Addresses

When a ZEN Support Software is connected, the node address set on the ZEN Support Software must match the node address set on the CPU Unit. Communications cannot be performed if the node addresses do not match. Use the following procedure to set the node addresses.

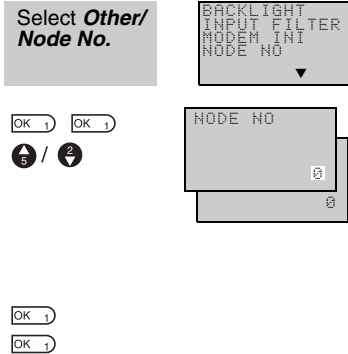

Press the **OK** Button to display the current settings.

Press the **OK** Button again to enable the node address to be set.

Use the **Up/Down** and **Right/Left** Buttons to set the node address between 0 and 9.

Press the **OK** Button to confirm the setting.

Press the **OK** Button again to complete the setting.

Note The ZEN must be connected 1:1 to the computer, i.e., only one ZEN can be connected to the computer at the same time.

SECTION 6

Troubleshooting

This section lists the error messages and provides probable causes and countermeasures for troubleshooting.

- 6-1 Troubleshooting..... 102
- 6-2 Error Messages..... 102
- 6-3 Deleting Error Messages 104

6-1 Troubleshooting

Search for the cause of the error and take immediate countermeasures if ERR or any other error message appears on the LCD screen (for LCD-type CPU Units) or the ERROR indicator is lit (on LED-type CPU Units).

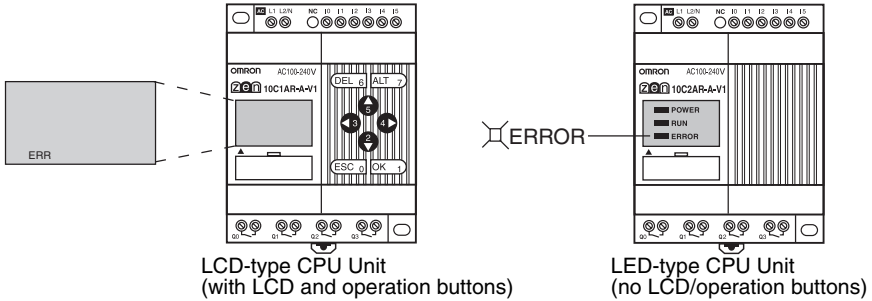

6-2 Error Messages

The following tables list the error messages that are displayed when an error occurs.

Power ON but No Operation

Error message	Probable cause	Possible solution
MEMORY ERR	Program error.	The ladder program and parameter settings have been cleared. Write a program to the ZEN again.
I/O BUS ERR	Expansion I/O Unit connection error.	Turn OFF the power supply and check that the Expansion I/O Units are connected properly.
UNIT OVER	More than 3 Expansion I/O Units connected.	Turn OFF the power supply and reduce the number of Expansion I/O Units to 3 or less.
I/O VRFY ERR	Bit type that cannot be used with system configuration included in ladder program. (See note.)	Remove the illegal bit type from the program.

Note I/O Verification Error

Expansion I/O Unit I/O bits (X/Y): Bit not allocated in system configuration has been used.

Analog comparators (A): Used with AC power supply type.

Weekly timers (@)/Calendar timers (*): Used with ZEN without calendar/clock function.

Display function (D):

- For AC power supply types, analog-converted values (I4/I5 or Ia/Ib) are specified as the displayed items.
- For types without calendar/clock function, the date (DAT), day/month (DAT1), and time (CLK) are specified as the displayed items.

Error at Power ON or During Operation

Error message	Probable cause	Possible solution
I/O BUS ERR	Expansion I/O Unit connection error.	Turn OFF the power supply and check that the Expansion I/O Unit is connected properly.
MEMORY ERR	Program error.	Execute the All Clear operation and then re-write the program.
I2C ERR	Communications error between Memory and RTC.	Press any operation button and clear the error. Replace the CPU Unit if the error occurs frequently.

Error During Program Transfer from Memory Cassette

Error message	Probable cause	Possible solution
M/C ERR	Memory cassette program error.	Save the error-free program to the Memory Cassette again.

Note Use the ZEN Support Software to read error messages for LED-type CPU Units.

6-3 Deleting Error Messages

A flashing error message is displayed when an error occurs. Turn OFF the power supply and remove the cause of the error.

Press any operation button to delete the error message. Once the error has been removed the display will return to normal.

Error Message
Display
Screen

```
I/O BUS ERR
```

Press either the **ESC**, **OK**, **DEL**, **ALT**, **Left/Right**, or **Up/Down** Buttons. Any button can be pressed to delete the error message.

```
M013:15 STOP  
I:oooooo  
Q:oooo
```

Press any button to return to normal display.

Note The error display will remain for internal errors that cannot be fixed, such as I/O Bus errors and I/O Unit Over errors.

```
M013:15 STOP  
I:oooooo  
Q:oooo  
ERR
```

↑ ERR will remain on the display.

Appendix A

Product Configurations

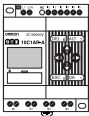
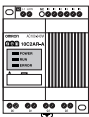

CPU Units with 10 I/O Points

Shape	Power supply	Inputs		Outputs		Calendar and clock function	Model number
LCD type With LCD and operation buttons 	100 to 240 VAC, 50/60 Hz	100 to 240 VAC	6 inputs	Relays	4 outputs	Yes	ZEN-10C1AR-A-V1
	(Not isolated)						
	24 VDC	24 VDC		Transistors			
	(Not isolated)						
	24 VDC	24 VDC					
(Not isolated)							
LED type No LCD nor operation buttons 	100 to 240 VAC, 50/60 Hz	100 to 240 VAC	6 inputs	Relays	4 outputs	No	ZEN-10C2AR-A-V1
	(Not isolated)						
	24 VDC	24 VDC		Transistors			
	(Not isolated)						
	24 VDC	24 VDC					
(Not isolated)							

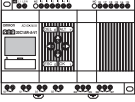
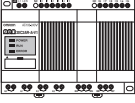

CPU Units with 20 I/O Points

Shape	Power supply	Inputs		Outputs		Calendar and clock function	Model number
LCD type With LCD and operation buttons 	100 to 240 VAC, 50/60 Hz	100 to 240 VAC	12 inputs	Relays	8 outputs	Yes	ZEN-20C1AR-A-V1
	(Not isolated)						
	24 VDC	24 VDC					Transistors
	(Not isolated)						
LED type No LCD nor operation buttons 	100 to 240 VAC, 50/60 Hz	100 to 240 VAC	12 inputs	Relays	8 outputs	No	ZEN-20C2AR-A-V1
	(Not isolated)						
	24 VDC	24 VDC		Transistors			
	(Not isolated)						



Programming Device

Name and appearance	Functions	Model number
ZEN Support Software 	Runs on Windows 95, 98, ME, 2000, XP, or NT4.0 Service Pack 3 (CD-ROM) Used for offline programming, all parameter settings, program transfers, and printing.	ZEN-SOFT01-V3
Personal Computer Connecting Cable 	Connects the computer and ZEN when the ZEN Support Software is used. (Cable length: 2 m)	ZEN-CIF01

Expansion I/O Units

No. of I/O points	Inputs		Outputs		Model number
8 I/O 	100 to 240 VAC (isolated)	4 inputs	Relays	4 outputs	ZEN-8EAR
	24 VDC (isolated)				ZEN-8EDR
			Transistors		ZEN-8EDT
4 inputs 	100 to 240 VAC (isolated)		---		ZEN-4EA
	24 VDC (isolated)				ZEN-4ED
4 outputs 	---	---	Relays	4 outputs	ZEN-4ER

Optional Products

Name and appearance	Functions		Model number
Memory Cassette 	EEP-ROM Used to save and copy programs.		ZEN-ME01
Battery Unit 	Uses a battery to back up programs and data. Mount a Battery Unit if the loss of calendar, clock, holding bit, holding timer, and counter present values will cause problems in systems with long power interruptions. (Battery life: 10 years minimum)		ZEN-BAT01
Training Kit	This kit is recommended for first-time users. Contains the following products and manuals as a kit. CPU Unit ZEN-SOFT01-V3 ZEN Support Software ZEN-CIF01 Personal Computer Connecting Cable ZEN Operation Manual (Z183) Support Software Operation Manual (Z184)	ZEN-10C1AR-A-V1 CPU Unit (AC power supply)	ZEN-KIT01-EV3
		ZEN-10C1DR-D-V1 CPU Unit (DC power supply)	ZEN-KIT02-EV3

Appendix B

Specifications

General Specifications

Item		Specifications	
Model numbers	LCD type	ZEN-10C1AR-A-V1 ZEN-10C2AR-A-V1	ZEN-10C1DR-D-V1 ZEN-20C1DR-D-V1 ZEN-10C1DT-D-V1 ZEN-20C1DT-D-V1
	LED type	ZEN-10C2AR-A-V1 ZEN-20C2AR-A-V1	ZEN-10C2DR-D-V1 ZEN-20C2DR-D-V1 ZEN-10C2DT-D-V1 ZEN-20C2DT-D-V1
Power supply voltage		100 to 240 VAC, 50/60 Hz	24 VDC
Allowable power supply voltage		85 to 264 VAC, 47/63 Hz	20.4 to 26.4 VDC
Power consumption (CPU Unit + 3 Expansion I/O Units)		30 VA max.	6.5 W max.
Inrush current		40 A max.	20 A max.
Insulation resistance		20 M Ω (at 500 VDC) min. between power supply AC external terminals and all input terminals, and relay or transistor outputs	
Dielectric strength		2300 VAC, 50/60 Hz for 1 min (leakage current 1 mA max.) between power supply AC external terminals and all input terminals, and relay or transistor outputs	
Noise immunity		Conforms to IEC61000-4-4, 2 kV (power supply line)	
Vibration resistance		Conforms to JISC0040, 10 to 57 Hz, amplitude 0.075 mm 57 to 150 Hz, acceleration 9.8 m/s ² 80 min in X, Y, and Z directions (Sweep time 8 min x 10 sweeps = 80 mins total.)	
Shock resistance		Conforms to JIS C004, 147 m/s ² 3 times in X, Y, and Z directions	
Ambient temperature		LCD type (with LCD and operation buttons): 0 to 55°C LED type (no LCD/operation buttons): -25 to 55°C	
Ambient humidity		10% to 90% (with no condensation)	
Environmental conditions		No corrosive gases.	
Storage temperature		LCD type (with LCD and operation buttons): -20 to 75°C LED type (no LCD/operation buttons): -40 to 75°C	
Terminal block		Solid-wire terminal block	

Item	Specifications	
Power supply holding time	10 ms min.	2 ms min.
Weight	300 g max.	
Enclosure rating	IP20 (Mounted inside a control panel)	

Note The CPU Units with transistor output is scheduled to be released soon.

Characteristics

Item	Specifications	
Control	Stored program	
I/O control	Cyclic scan	
Programming language	Ladder	
Program capacity	96 lines (up to 3 inputs and 1 output per line)	
Maximum control I/O points	CPU Units with 10 I/O points	34 points (with 3 Expansion I/O Units with 8 I/O points each)
	CPU Units with 20 I/O points	44 points (with 3 Expansion I/O Units with 8 I/O points each)
Memory areas	CPU Unit input bits (I)	CPU Units with 10 I/O Points: I0 to I5, 6 bits
		CPU Units with 20 I/O Points: I0 to Ib, 12 bits
	CPU Unit output bits (Q)	CPU Units with 10 I/O Points: Q0 to Q3, 4 bits
		CPU Units with 20 I/O Points: Q0 to Q7, 8 bits
	Expansion I/O Unit input bits (X)	X0 to Xb, 12 bits (See note.)
	Expansion I/O Unit output bits (Y)	Y0 to Yb, 12 bits (See note.)
	Work bits (M)	M0 to Mf, 16 bits
	Holding bits (H)	H0 to Hf, 16 bits
	Button switches (B)	B0 to B7, 8 bits (LCD-type CPU Unit only)
	Timers (T)	T0 to Tf, 16 timers
	Holding timers (#)	#0 to #7, 8 timers
	Weekly timers (@)	@0 to @f, 16 timers (CPU Units with built-in calendar and clock only)
	Calendar timers (*)	*0 to *f, 16 timers (CPU Units with built-in calendar and clock only)
	Counters (C)	C0 to Cf, 16 counters
	Display bits (D)	D0 to Df, 16 bits (LCD-type CPU Unit only)
Analog comparator (A)	A0 to A3, 4 comparators (CPU Units with DC power supply only)	
Comparator (P)	P0 to Pf, 16 comparators	
LCD	12 columns x 4 lines, with backlight (LCD-type CPU Unit only)	
Operation buttons	8 (4 Cursor Buttons, 4 operation buttons) (LCD-type CPU Unit only)	
User program backup	Internal EEPROM, Memory Cassette (optional)	

Item	Specifications
Power interruption hold	Internal RAM: Super capacitor (or optional battery) for holding bits and timer/counter present values. Calendar and clock: Super capacitor (or optional battery) for date, day, and time. Holding time for super capacitor: 2 days max. (25°C)
Calendar and clock function	Available for ZEN-□□C1□□-□(-V1) only. Precision: ±2 min/month (25°C)

- Note**
1. The sizes of some memory areas are smaller for pre-V1 CPU Units.
 2. Available when an Expansion I/O Unit is connected.

Input Specifications

CPU Unit

AC Inputs (Not Isolated) (V1 and Pre-V1 CPU Units)

Item	Specifications	Circuit drawing
Input voltage	100 to 240 VAC +10%, -15%, 50/60 Hz	
Input impedance	680 kΩ	
Input current	0.15 mA/100 VAC, 0.35 mA/240 VAC	
ON voltage	80 VAC min.	
OFF voltage	25 VAC max.	
ON response time	50 ms or 70 ms at 100 VAC (See note.)	
OFF response time	100 ms or 120 ms at 240 VAC (See note.)	

Note Can be selected using the input filter settings.

DC Inputs IN0 to IN3 (IN0 to IN9) (V1 CPU Units)

Item	Specifications	Circuit drawing
Input voltage	24 VDC +10%, -15%	
Input impedance	5 kΩ	
Input current	5 mA Typical	
ON voltage	16.0 VDC min.	
OFF voltage	5.0 VDC max.	
ON response time	15 ms or 50 ms (See note.)	
OFF response time		

Note Can be selected using the input filter settings.

DC Inputs IN0 to IN3 (Not Isolated) (Pre-V1 CPU Units)

Item	Specifications	Circuit drawing
Input voltage	24 VDC +10%, -15%	
Input impedance	4.8 kΩ	
Input current	5 mA, Typical	
ON voltage	16.0 VDC min.	
OFF voltage	5.0 VDC max.	
ON response time	15 ms or 50 ms (See note.)	
OFF response time		

Note Can be selected using the input filter settings.

DC Inputs I4 (Ia) and I5 (Ib) (V1 CPU Units)

Item		Specifications	Circuit drawing
DC inputs	Input voltage	24 VDC +10%, -15%	
	Input impedance	5 kΩ	
	Input current	5 mA, Typical	
	ON voltage	14.0 VDC min.	
	OFF voltage	4.5 VDC max.	
	ON response time	15 ms or 50 ms (See note.)	
	OFF response time		
Analog inputs	Input range	0 to 10 V	
	External input impedance	150 kΩ min.	
	Resolution	0.1 V (1/100 FS)	
	Overall accuracy (-25°C to 55°C)	10% FS	
	AD conversion data	0 to 10.5 V in 0.1 V increments	

Note Can be selected using the input filter settings.

DC Inputs I4 (Ia) and I5 (Ib) (Not Isolated) (Pre-V1 CPU Units)

Item		Specifications	Circuit drawing
DC inputs	Input voltage	24 VDC +10%, -15%	
	Input impedance	5 kΩ	
	Input current	5 mA, Typical	
	ON voltage	16.0 VDC min.	
	OFF voltage	5.0 VDC max.	
	ON response time	15 ms or 50 ms (See note.)	
	OFF response time		
Analog inputs	Input range	0 to 10 V	
	External input impedance	150 kΩ min.	
	Resolution	0.1 V (1/100 FS)	
	Overall accuracy (-25°C to 55°C)	10% FS	
	AD conversion data	0 to 10.5 V in 0.1 V increments	

Note Can be selected using the input filter settings.

Expansion I/O Units

AC Inputs (Photocoupler Isolated)

Item	Specifications	Circuit drawing
Input voltage	100 to 240 VAC +10%, -15%, 50/60 Hz	
Input impedance	83 kΩ	
Input current	1.2 mA/100 VAC, 2.9 mA/240 VAC	
ON voltage	80 VAC min.	
OFF voltage	25 VAC max.	
ON response time	50 ms or 70 ms at 100 VAC (See note.) 100 ms or 120 ms at 240 VAC (See note.)	
OFF response time		

Note Can be selected using the input filter settings.

DC Inputs (Photocoupler Isolated)

Item	Specifications	Circuit drawing
Input voltage	24 VDC +10%, -15%	
Input impedance	4.7 kΩ	
Input current	5 mA, Typical	
ON voltage	16.0 VDC min.	
OFF voltage	5.0 VDC max.	
ON response time	15 ms or 50 ms (See note.)	
OFF response time		

Note Can be selected using the input filter settings.

Output Specifications

Relay Output Type (CPU Unit/Expansion I/O Units)

Item	Specifications	Circuit drawing	
Max. switching capacity	250 VAC/8 A ($\cos\phi = 1$) 24 VDC/5 A	<p>Each circuit is made up of an independent common circuit.</p>	
Min. switching capacity	5 VDC, 10 mA		
Relay life	Electrical		Resistive load: 50,000 times Inductive load: 50,000 times ($\cos\phi = 1$)
	Mechanical		10 million times
ON response time	15 ms max.		
OFF response time	5 ms max.		

The life, under the worst conditions, of the output contacts used in ZEN relay outputs is given in the above table. Guidelines for the normal life of the relays is shown in the following diagram.

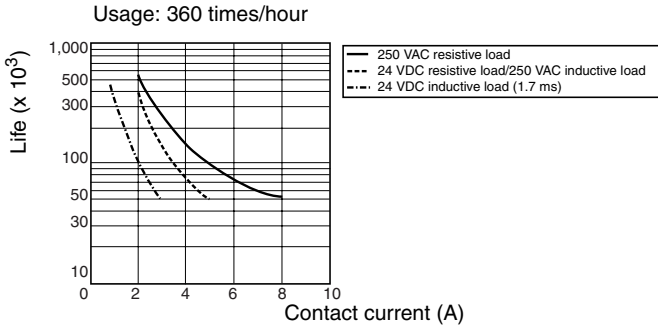

Transistor Output Type (CPU Unit/Expansion I/O Units)

Item	Specifications	Circuit drawing
Max. switching capacity	20.4 to 26.4 VDC 500 mA	<p>Each circuit is made up of an independent common circuit.</p>
Leakage current	0.1 mA max.	
Residual voltage	1.5 V max.	
ON response time	1 ms max.	
OFF response time	1 ms max.	

External Dimensions

- CPU Units with 10 I/O Points (LCD and LED Types)

- Dimensions with the Battery Unit Mounted

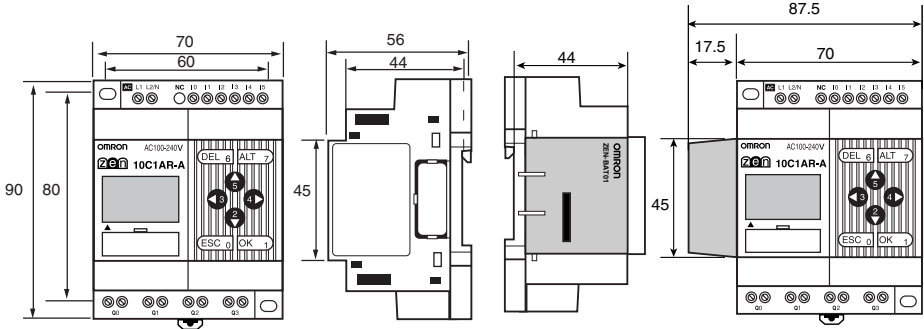

- CPU Units with 20 I/O Points (LCD and LED Types)

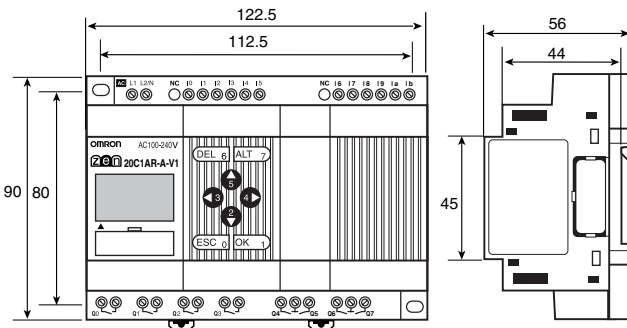

- Dimensions with the Battery Unit Mounted

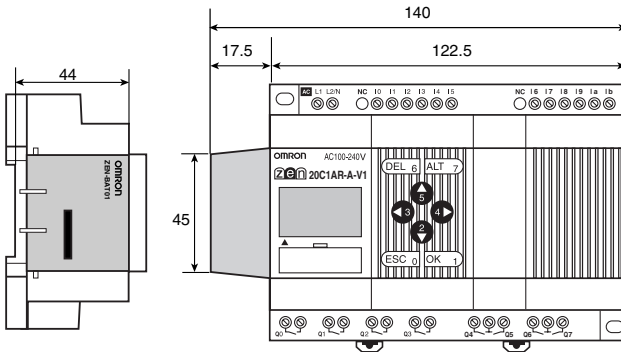

- Expansion I/O Units
(4-input/4-output/8 I/O)

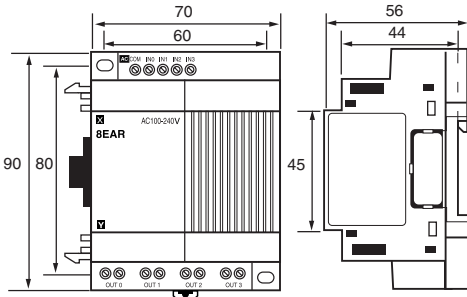

- Unit Mounting Hole Dimensions
(Same for All Units)

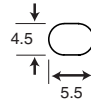

Units: mm

Appendix C

Ladder Program Execution

Executing Ladder Programs

ZEN executes up to 96 lines of a ladder program in one cycle from first to last line. Starting from the first line of the bus bar, the ZEN repeatedly executes each line from left to right.

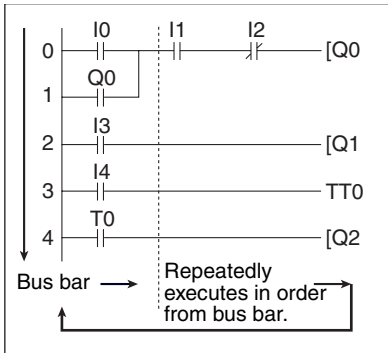

- Note**
1. The time from when processing starts at the bus bar until the bus bar is returned to at the first line again to execute the entire ladder program is called cycle time.
 2. The output ON/OFF results cannot be used for inputs within the same cycle. The result scan be used from the next cycle onwards

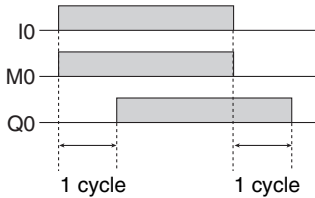
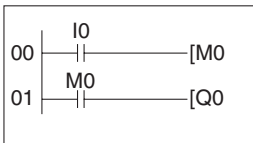

The Q0 ON/OFF result is reflected one cycle after M0 turns ON or OFF.

Ladder Program Execution Time

Refer to the following table for ZEN execution times. The execution times are provided as a guide. External factors, button operations, execution of ZEN Support Software operations, and timing of the processing affects the actual processing times. The cycle time is the sum of the common processing time, the processing time taken when Expansion I/O Units are connected, and the ladder program execution time.

Common Processing Time

Model	Common processing time
ZEN-10C1AR-A	0.85 ms
ZEN-10C1DR-D	
ZEN-10C2AR-A	0.2 ms
ZEN-10C2DR-D	

Expansion I/O Unit Processing Time

0.15 ms/per Expansion I/O Unit.

Ladder Program Execution Time

Per line		25 μ s	*1
Per output	CPU Unit output bits (Q)	4 μ s	*2
	Expansion I/O Unit output bits (Y)		
	Work bits (M)		
	Holding bits (H)		
	Timers (T)/Holding timers (#)		
	Counters (C)	10 μ s	
	Display bits (D)	25 μ s	
Weekly timers (@); per input		3 μ s	*4
Calendar timers (*); per input		2 μ s	
Analog comparators (A); per input		1 μ s	
Comparators (P); per input		15 μ s	*5

Example Calculation of Ladder Program Execution Time

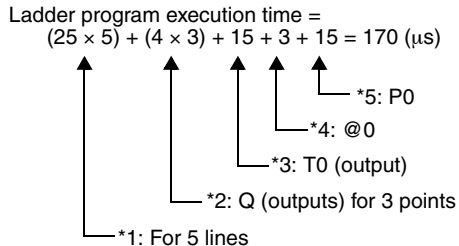
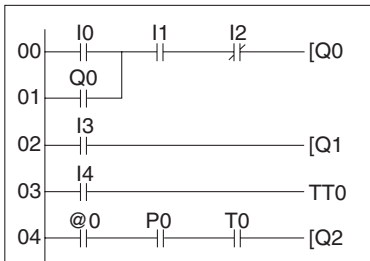

Appendix D

Application Examples

Lighting Pattern Control

Application

The ZEN can help conserve energy if the lighting patterns required for offices and similar environments are set to the ZEN.

Use the switch operation to switch between lighting patterns.

Operation	Switch	Lighting group			
		1 (Q0)	2 (Q1)	3 (Q2)	4 (Q3)
All lights ON	SW 1 (I0)	ON	ON	ON	ON
Pattern 1	SW 2 (I1)	ON	OFF	ON	OFF
Pattern 2	SW 3 (I2)	ON	ON	OFF	OFF
All lights OFF	SW 4 (I3)	OFF	OFF	OFF	OFF

System Configuration

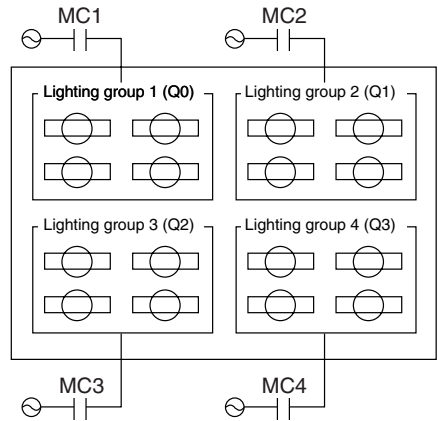
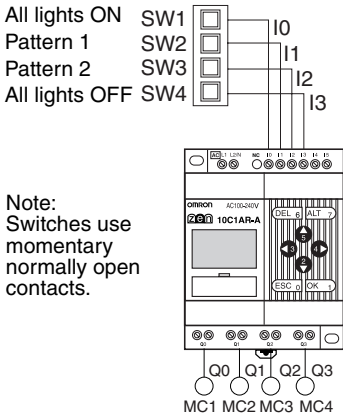

Program Example

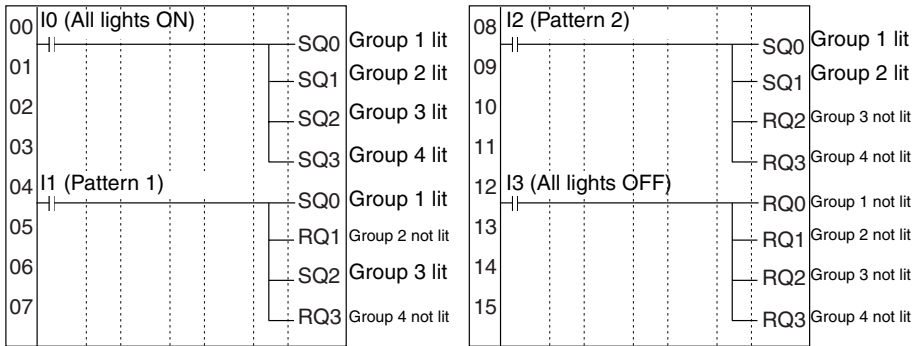

Escalator with Automatic Operation Function (Weekly Timer, OFF Delay Timer)

Application

The ZEN can be simply used to conserve energy for an escalator with an automatic operation function. The escalator can be set to operate continuously from 7:00 to 10:00 and 17:00 to 22:00 weekdays and then operate at other times and on weekends only when people step on the escalator.

System Configuration

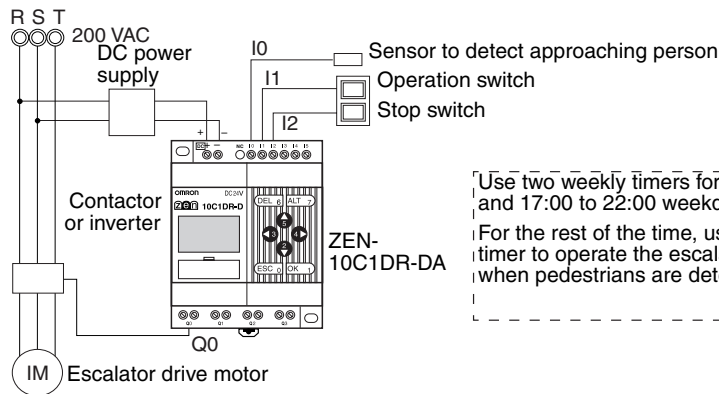

Use two weekly timers for the 7:00 to 10:00 and 17:00 to 22:00 weekday operation.
 For the rest of the time, use an OFF delay timer to operate the escalator for 3 minutes when pedestrians are detected.

Program Example

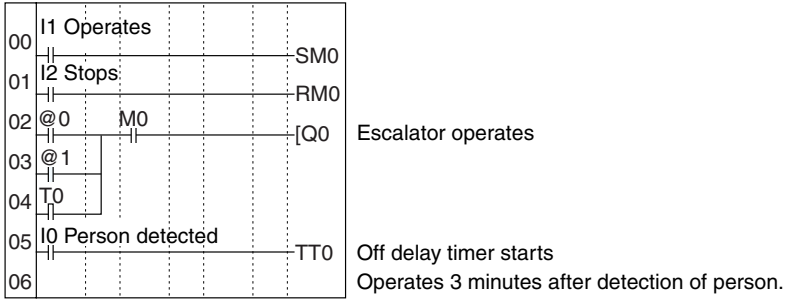

Parameter Settings

Weekly timer @0
(Mon to Fri: 7:00 to 10:00)

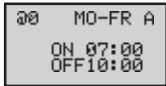

Weekly timer @1
(Mon to Fri: 17:00 to 22:00)

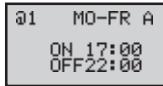

OFF delay timer T0

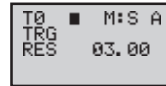

Water Supply Tank Control

Application

Basic water supply control is possible with the 61F Switch (without float) alone, however relay logic is required for inverter control of high-speed operation (when empty) and low-speed operation (when half-full).

System Configuration

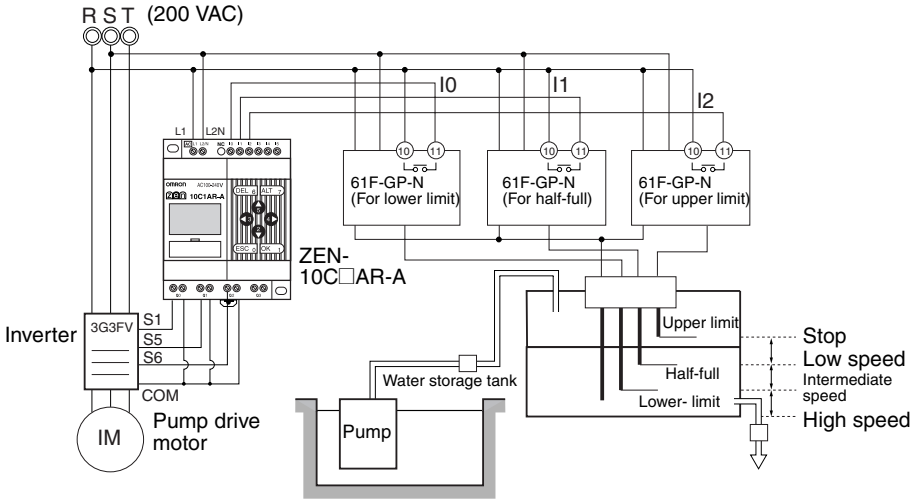

Program Example

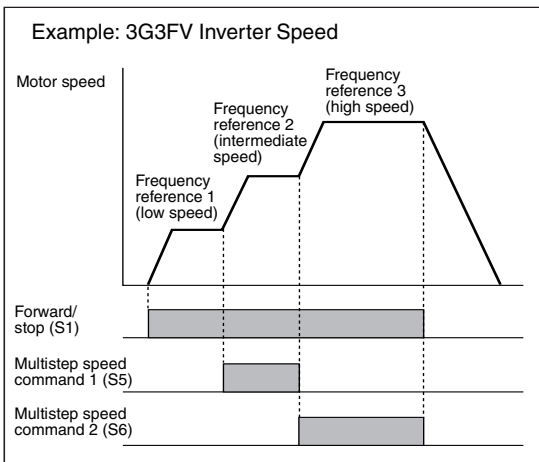
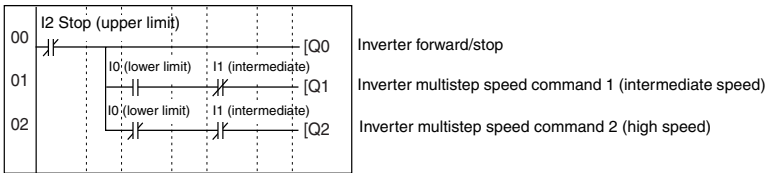

Greenhouse Air Circulation Control (1/3) (Bit Logic and Timer)

Application

The ZEN can be used to control circulation intermittently at set times. This circulates the carbon dioxide and warm air around plants in a greenhouse.

In this example, two circulation fans are operated at set intervals. The starting current is kept to a minimum and, as a result, the circulation fans are set to start operating at different times.

System Configuration

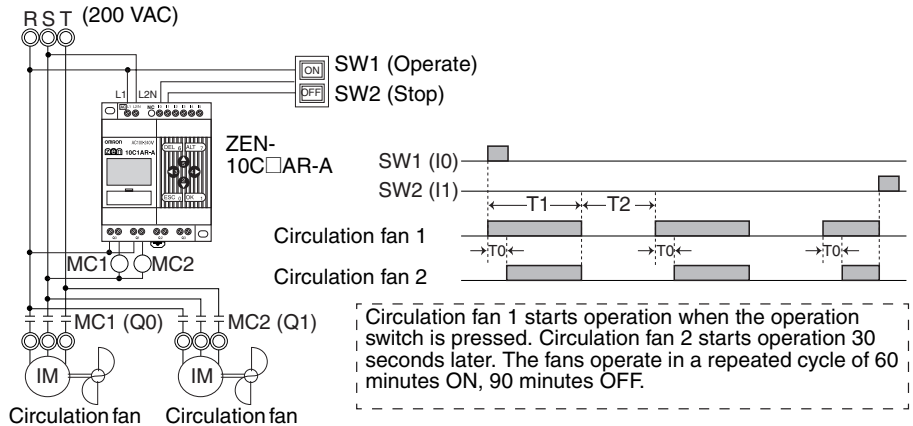

Program Example

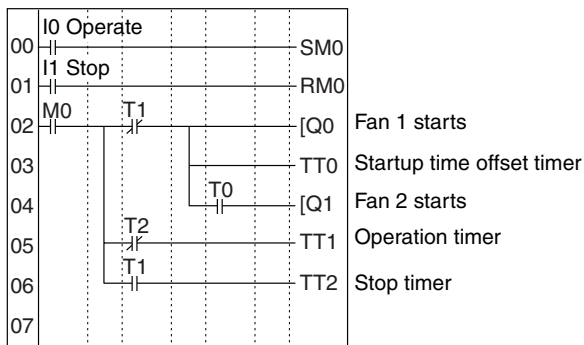

Parameter Settings

Offset Start Timer
Setting T0

T0	X	S	A
TRG			
RES		30.00	

Set to 30 seconds.

Operation timer setting T1

T1	X	H:S	A
TRG			
RES		01.00	

Set to 1 hour.

Operation timer setting T2

T2	X	H:S	A
TRG			
RES		01.30	

Set to 1 hour 30 seconds.

Greenhouse Air Circulation Control (2/3) (Calendar Timer and Weekly Timer)

Application

The ZEN can be used to operate circulation fans during winter nights only.

In this example, the circulation fans operate only at night (19:00 to 6:00) during winter (November 15 to March 20).

During the operation period, the fans operate intermittently, 60 minutes ON, 30 minutes OFF. The low startup current results in a 30 second difference in the fan startup times.

The start and stop operation days during winter (November 15 and March 20) are set using the calendar timer (*0).

The start and stop operation times during the night (19:00 and 6:00) are set using the weekly timer (@0).

The startup time difference and operate/stop cycles are set using the timer (T0 to T2).

System Configuration

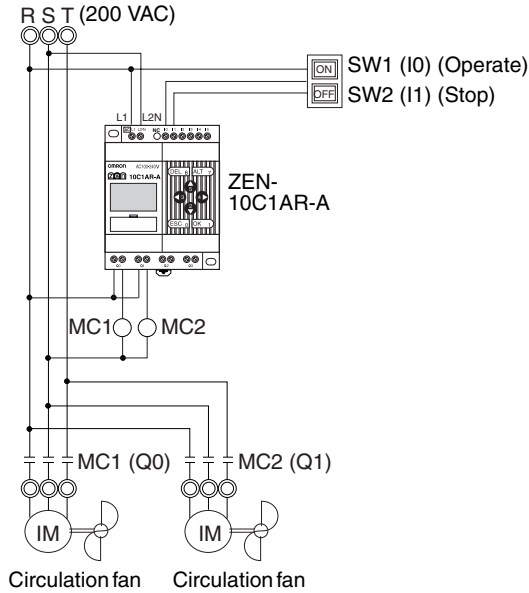

Program Example

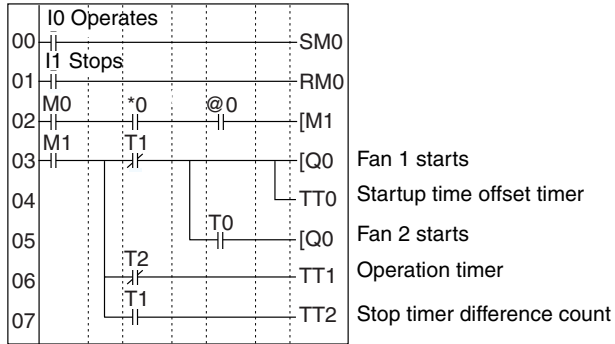

Parameter Settings

Calendar Timer Setting *0

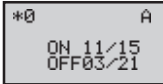

Start Nov 15 and stop Mar 20

Weekly timer setting @0

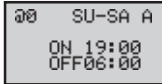

Start at 19:00 and stop at 6:00

Offset startup time setting T0

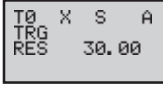

Set to 30 seconds.

Operation time setting T1

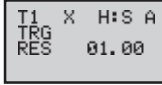

Set to 1 hour.

Stop time setting T2

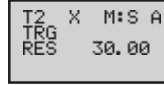

Set to 30 minutes.

Greenhouse Air Circulation Control (3/3) (Analog Comparator)

Application

The ZEN can be used to start the circulation fans once the temperature has reached a set level. A low startup current would result from a difference in the fan startup times.

System Configuration

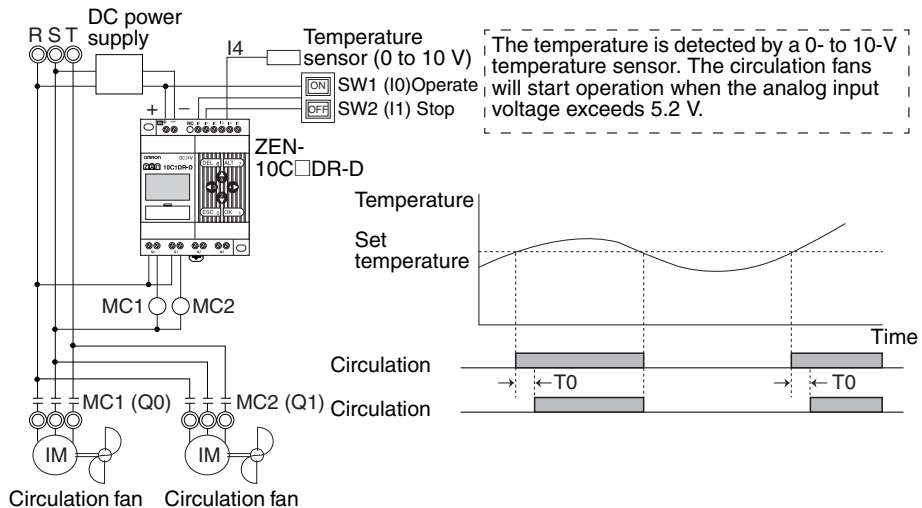

Program Example

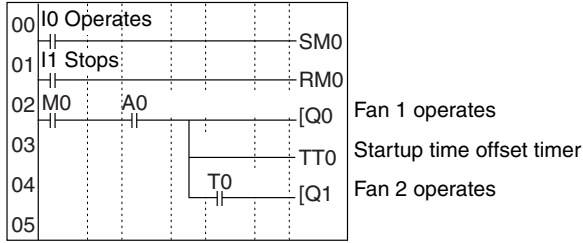

Parameter Settings

Analog Comparator A0

Offset startup timer setting T0

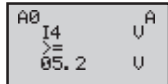

Set temperature \geq 5.2V

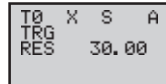

Set to 30 seconds.

Annunciator (Flashing Pulse Timer)

Application

The ZEN can be used to make an alarm light flash when errors occur.

In this example, a flashing pulse timer is used to make an alarm light flash when errors occur. Ladder programs can be created easily when a flashing pulse timer is used.

System Configuration

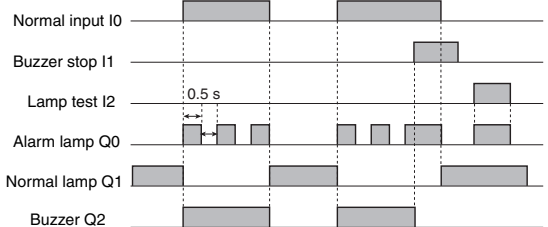
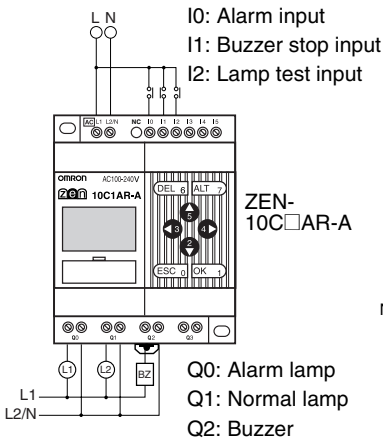

Program Example

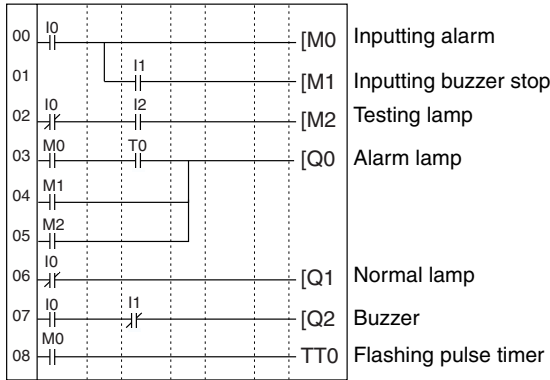

Parameter Settings

Flashing Pulse Timer

T0	F	S	A
TRG			
RES	00.	50	

Set to flash at 0.5 s intervals.

Coin-operated Carwash (Holding Bits and Holding Timer)

Application

The ZEN can be used to change the operating time of a machine, such as a coin-operated car wash, depending on the number of coins inserted.

If a holding timer is used and holding bits used for the self-holding bits, the remaining time will not be reset if there are unexpected power interruptions.

In this example, the carwash operates for 3 minutes if one coin is inserted, 6 minutes if two coins are inserted, and 9 minutes if 3 coins are inserted.

A holding timer is used as the timer.

System Configuration

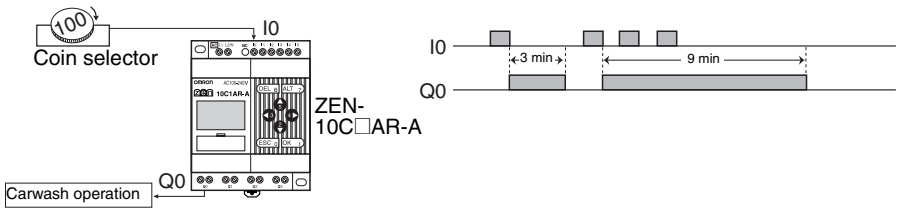

Program Example

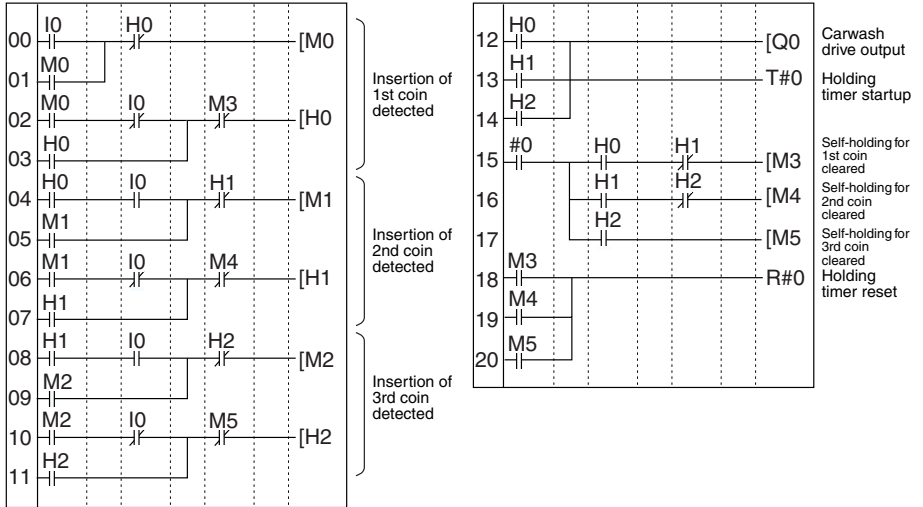

Parameter Settings

Holding Timer

#0	X	M:S A
TRG		
RES	03.00	

Set to 3 minutes.

Warming Moulding Machines (Weekly Timer and Bit Logic)

Application

The ZEN can be used to improve moulding efficiency by warming up the moulding machine before the work shift starts. This allows moulding work to begin immediately at the start of the work shift.

When work shifts vary, pre-set weekly timers can be selected using a switch.

System Configuration

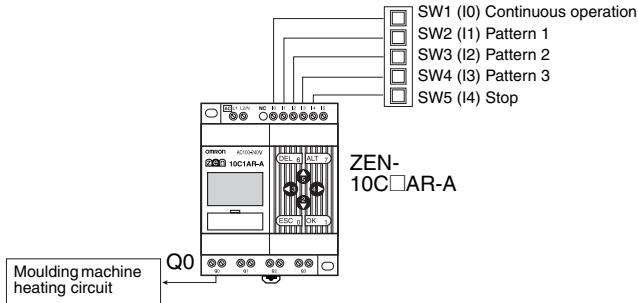

Program Example

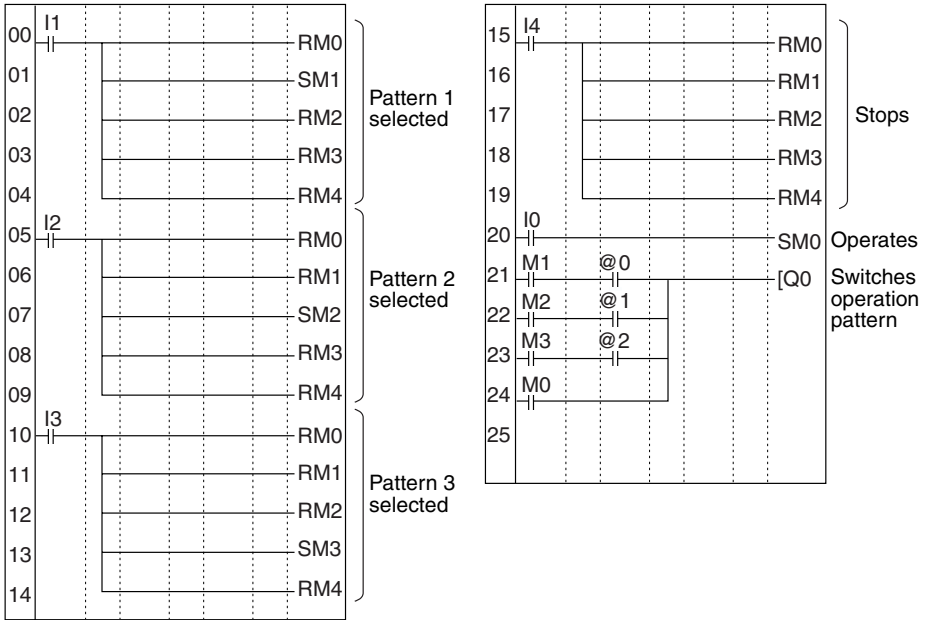

Parameter Settings

Weekly Timer Setting @0 to @2



Appendix E

Allocations and Setting Sheets

I/O Allocations for CPU Units with 10 I/O Points

I/O	Unit name	Bit	Input device	Input	IN filter
Input bits	CPU Unit	I0		AC DCV	Yes No
		I1			
		I2			
		I3			
		I4	Normal input Analog voltage input		Yes No
	Expansion I/O Unit	X0		AC DCV	Yes No
		X1			
		X2			
	Expansion I/O Unit	X3		AC DCV	Yes No
		X4			
		X5			
		X6			
	Expansion I/O Unit	X7		AC DCV	Yes No
		X8			
		X9			
Xa					
Xb					

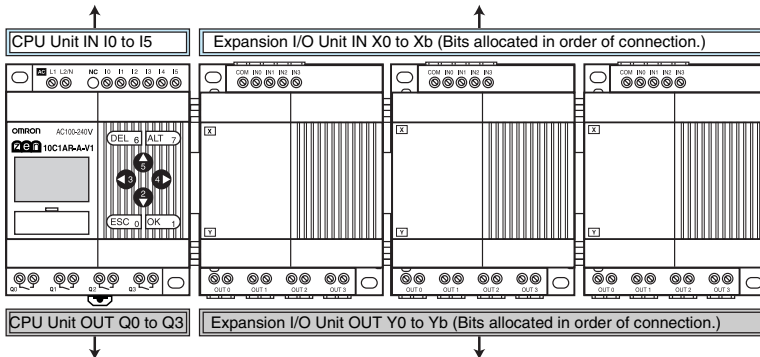

I/O	Unit name	Bit	Output device name and specifications
Output bits	CPU Unit	Q0	AC DC V A
		Q1	AC DC V A
		Q2	AC DC V A
		Q3	AC DC V A
	Expansion I/O Unit	Y0	AC DC V A
		Y1	AC DC V A
		Y2	AC DC V A
		Y3	AC DC V A
	Expansion I/O Unit	Y4	AC DC V A
		Y5	AC DC V A
		Y6	AC DC V A
		Y7	AC DC V A
Expansion I/O Unit	Y8	AC DC V A	
	Y9	AC DC V A	
	Ya	AC DC V A	
		Yb	AC DC V A

I/O Allocations for CPU Units with 20 I/O Points

I/O	Unit name	Bit	Input device	Input	IN filter
Input bits	CPU Unit	I0		AC DCV	Yes No
		I1			
		I2			
		I3			
		I4			
		I5			
		I6			
		I7			
		I8			
		I9			
		Ib	Normal input Analog voltage input		
	Expansion I/O Unit	X0		AC DCV	Yes No
		X1			
		X2			
		X3			
	Expansion I/O Unit	X4		AC DCV	Yes No
		X5			
		X6			
		X7			
	Expansion I/O Unit	X8		AC DCV	Yes No
		X9			
		Xa			
		Xb			

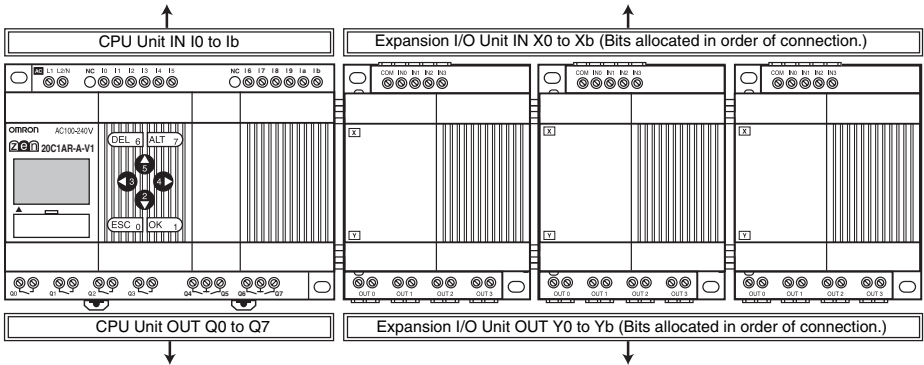

I/O	Unit name	Bit	Output device name and specifications
Output bits	CPU Unit	Q0	AC DC V A
		Q1	AC DC V A
		Q2	AC DC V A
		Q3	AC DC V A
		Q4	AC DC V A
		Q5	AC DC V A
		Q6	AC DC V A
		Q7	AC DC V A
	Expansion I/O Unit	Y0	AC DC V A
		Y1	AC DC V A
		Y2	AC DC V A
		Y3	AC DC V A
	Expansion I/O Unit	Y4	AC DC V A
		Y5	AC DC V A
		Y6	AC DC V A
		Y7	AC DC V A
	Expansion I/O Unit	Y8	AC DC V A
		Y9	AC DC V A
		Ya	AC DC V A
		Yb	AC DC V A

Work and Holding Bit Allocations

Bit type	Address	Application	Bit type	Address	Application
Work bits	M0		Holding bits	H0	
	M1			H1	
	M2			H2	
	M3			H3	
	M4			H4	
	M5			H5	
	M6			H6	
	M7			H7	
	M8			H8	
	M9			H9	
	Ma			Ha	
	Mb			Hb	
	Mc			Hc	
	Md			Hd	
	Me			He	
Mf		Hf			

Timer and Holding Timer Settings

Timer	Address	Operation setting(See note.)	Setting time units	Set time	Application
Timer	T0	X ■ O F	H:M M:S S		
	T1	X ■ O F	H:M M:S S		
	T2	X ■ O F	H:M M:S S		
	T3	X ■ O F	H:M M:S S		
	T4	X ■ O F	H:M M:S S		
	T5	X ■ O F	H:M M:S S		
	T6	X ■ O F	H:M M:S S		
	T7	X ■ O F	H:M M:S S		
	T8	X ■ O F	H:M M:S S		
	T9	X ■ O F	H:M M:S S		
	Ta	X ■ O F	H:M M:S S		
	Tb	X ■ O F	H:M M:S S		
	Tc	X ■ O F	H:M M:S S		
	Td	X ■ O F	H:M M:S S		
	Te	X ■ O F	H:M M:S S		
Tf	X ■ O F	H:M M:S S			
Holding timer	#0	X	H:M M:S S		
	#1	X	H:M M:S S		
	#2	X	H:M M:S S		
	#3	X	H:M M:S S		
	#4	X	H:M M:S S		
	#5	X	H:M M:S S		
	#6	X	H:M M:S S		
	#7	X	H:M M:S S		

Note X: ON delay; ■: OFF delay; O: One-shot pulse; F: Flashing pulse

Counter Settings

Counter address	Setting (No. of times)	Application	
C0			Incrementing: Decrementing: Reset:
C1			Incrementing: Decrementing: Reset:
C2			Incrementing: Decrementing: Reset:
C3			Incrementing: Decrementing: Reset:
C4			Incrementing: Decrementing: Reset:
C5			Incrementing: Decrementing: Reset:
C6			Incrementing: Decrementing: Reset:
C7			Incrementing: Decrementing: Reset:
C8			Incrementing: Decrementing: Reset:
C9			Incrementing: Decrementing: Reset:
Ca			Incrementing: Decrementing: Reset:
Cb			Incrementing: Decrementing: Reset:
Cc			Incrementing: Decrementing: Reset:
Cd			Incrementing: Decrementing: Reset:
Ce			Incrementing: Decrementing: Reset:
Cf			Incrementing: Decrementing: Reset:

Weekly Timer Settings

Weekly timer address	Start day	Stop day	Start time	Stop time	Application
@0	SU MO TU WE TH FR SA	SU MO TU WE TH FR SA None	:	:	
@1	SU MO TU WE TH FR SA	SU MO TU WE TH FR SA None	:	:	
@2	SU MO TU WE TH FR SA	SU MO TU WE TH FR SA None	:	:	
@3	SU MO TU WE TH FR SA	SU MO TU WE TH FR SA None	:	:	
@4	SU MO TU WE TH FR SA	SU MO TU WE TH FR SA None	:	:	
@5	SU MO TU WE TH FR SA	SU MO TU WE TH FR SA None	:	:	
@6	SU MO TU WE TH FR SA	SU MO TU WE TH FR SA None	:	:	
@7	SU MO TU WE TH FR SA	SU MO TU WE TH FR SA None	:	:	
@8	SU MO TU WE TH FR SA	SU MO TU WE TH FR SA None	:	:	
@9	SU MO TU WE TH FR SA	SU MO TU WE TH FR SA None	:	:	
@a	SU MO TU WE TH FR SA	SU MO TU WE TH FR SA None	:	:	
@b	SU MO TU WE TH FR SA	SU MO TU WE TH FR SA None	:	:	
@c	SU MO TU WE TH FR SA	SU MO TU WE TH FR SA None	:	:	
@d	SU MO TU WE TH FR SA	SU MO TU WE TH FR SA None	:	:	
@e	SU MO TU WE TH FR SA	SU MO TU WE TH FR SA None	:	:	
@f	SU MO TU WE TH FR SA	SU MO TU WE TH FR SA None	:	:	

Calendar Timer Settings

Calendar timer address	Start date	Stop date	Application
*0			
*1			
*2			
*3			
*4			
*5			
*6			
*7			
*8			
*9			
*a			
*b			
*c			
*d			
*e			
*f			

Analog Comparator Settings

Analog comparator address	Comparison data 1		Operator	Comparison data 2	
	Inputs	Input device and specifications		Input/ No. of points	Input device and specifications
A0	14 (Ia) 15 (Ib)		≤ ≥	15 (Ib) Constant (. V)	
A1	14 (Ia) 15 (Ib)		≤ ≥	15 (Ib) Constant (. V)	
A2	14 (Ia) 15 (Ib)		≤ ≥	15 (Ib) Constant (. V)	
A3	14 (Ia) 15 (Ib)		≤ ≥	15 (Ib) Constant (. V)	

Comparator Settings

Comparator address	Comparison data 1		Operator	Comparison data 2		
	Type	Content		Type	Content	Constant
P0	T□ #□ C□		≡	T□ #□ C□		
P1	T□ #□ C□		≡	T□ #□ C□		
P2	T□ #□ C□		≡	T□ #□ C□		
P3	T□ #□ C□		≡	T□ #□ C□		
P4	T□ #□ C□		≡	T□ #□ C□		
P5	T□ #□ C□		≡	T□ #□ C□		
P6	T□ #□ C□		≡	T□ #□ C□		
P7	T□ #□ C□		≡	T□ #□ C□		
P8	T□ #□ C□		≡	T□ #□ C□		
P9	T□ #□ C□		≡	T□ #□ C□		
Pa	T□ #□ C□		≡	T□ #□ C□		
Pb	T□ #□ C□		≡	T□ #□ C□		
Pc	T□ #□ C□		≡	T□ #□ C□		
Pd	T□ #□ C□		≡	T□ #□ C□		
Pe	T□ #□ C□		≡	T□ #□ C□		
Pf	T□ #□ C□		≡	T□ #□ C□		

Display Function Settings

Display bit address	Backlight/Display function display screen switching	Display start position	Display message	Application
D0	L0 L1 L2 L3	X: Y:		
D1	L0 L1 L2 L3	X: Y:		
D2	L0 L1 L2 L3	X: Y:		
D3	L0 L1 L2 L3	X: Y:		
D4	L0 L1 L2 L3	X: Y:		
D5	L0 L1 L2 L3	X: Y:		
D6	L0 L1 L2 L3	X: Y:		
D7	L0 L1 L2 L3	X: Y:		
D8	L0 L1 L2 L3	X: Y:		
D9	L0 L1 L2 L3	X: Y:		
Da	L0 L1 L2 L3	X: Y:		
Db	L0 L1 L2 L3	X: Y:		
Dc	L0 L1 L2 L3	X: Y:		
Dd	L0 L1 L2 L3	X: Y:		
De	L0 L1 L2 L3	X: Y:		
Df	L0 L1 L2 L3	X: Y:		

	Backlight	Display function display screen switching
L0	No	No
L1	Yes	No
L2	No	Yes
L3	Yes	Yes

CHR	Characters (12 digits max.)
DAT	Month/day (5 digits: □□/□□)
DAT1	Day/month (5 digits: □□/□□)
CLK	Hour:minutes (5 digits: □□:□□)
14/15	Analog conversion (4 digits: □□.□)
1a/1b	
T0 to Tf	Timer present value (5 digits: □□.□□)
#0 to #7	Holding timer present value (5 digits: □□.□□)
C0 to Cf	Counter present value (4 digits: □□□□)

Index

A

- additional functions for bit outputs 27
- allocations
 - allocation sheets 137
 - I/O allocations 29
- alternate operation 27, 58
- analog I/O 75
- application
 - examples 123
- available models 105

B

- backlight
 - changing automatic cutout time 92
- Battery Unit 14
 - mounting 96
- blank lines
 - deleting 66
- button switches 17
 - using 85

C

- calendar timers 74
- characteristics 111
- CLOCK 51
- comparators
 - addresses 57
 - analog 75
 - comparing present values 79
- conduit installation 34
- connection lines 60
 - deleting 65
- contrast
 - adjusting 93
- control panel
 - mounting 32

counters

- addresses 28, 57, 59
- comparing values 79
- using 70

CPU Units

- available models 105
- overview 2
- specifications 112, 116

D

- date
 - setting 51
- dimensions 32, 118
- DIN track 30
 - mounting 32
- display bits
 - addresses 28, 59
 - displaying messages 82
- display language 50
- display screen 16
- duct installation 33

E

- EC Directives xvi
- error messages
 - deleting 104
 - meaning 102
- Expansion I/O Units 15
 - available models 107
 - connecting 33
 - overview 2
 - specifications 115, 116

F

- false inputs 44
- features 8
- flashing pulse timer 67

H

holding timers 67

I

I/O bits

allocation 29

inductive loads 45, 47

input devices

connecting 42

inputs

analog 75

changing 64

deleting 65

input bits 27

input filter 90

stabilizing input operations 90

wiring input lines 35

writing 56

inrush current

suppressing 48

installation 32

internal holding bits 27

L

Ladder Program Edit Screen settings

analog inputs 77

calendar timers 74

comparing present values 79

counters 70

display bits 82

timers and holding timers 68

weekly timers 72

ladder programs

See programs

language

selecting display language 50

leakage current 44

limit switches

preventing false inputs 44

lines

inserting 65

M

memory

backup xx

memory areas 27, 57, 58

Memory Cassettes 9

mounting 97, 98

transferring programs 98

MONITOR 63

mounting 32

Battery Units 96

N

node addresses

setting 100

O

OFF delay timer 67

ON delay timer 67

one-shot pulse timer 67

operating mode 63

at startup xix

RUN mode 18, 20

STOP mode 18, 20

operation

confirming 62

preparation 30

operation buttons 10, 17

optional products 107

outputs

changing additional bit output functions 64

deleting 65

output bits 27

wiring output circuits 45

writing 58

overview 2

P

PARAMETER 20

Parameter Monitor Screen Display

analog comparators 78

calendar timers 75

- comparing present values 81
- counters 71
- timers and holding timers 69
- weekly timers 73
- Parameter Settings Screen settings
 - analog comparators 77
 - calendar timers 74
 - comparing present values 80
 - counters 71
 - display bits 83
 - timers and holding timers 68
 - weekly timers 72
- part names 10
- password
 - deleting 89
 - setting 89
- photoelectric switches
 - preventing false inputs 44
- power cables 33
- power supply
 - wiring 35
- precautions
 - applications xiii
 - operating environment xvi
 - safety xii
- Programming Device
 - available models 106
- programs
 - clearing 53
 - correcting 64
 - creating 52
 - examples 123
 - executing 121
 - execution time 122
 - protecting 88
 - writing 54
- proximity switches
 - preventing false inputs 44

R-S

- reset input 68, 70
- reset operation 27, 58
- screen
 - adjusting LCD screen contrast 93
- set operation 27, 58
- settings
 - setting sheets 137
- specifications
 - general 109
 - input 112
 - output 116
- summertime
 - setting 93
- Support Software 4
 - connecting 99
- switching capacity 116, 117
- system configuration 8
- system information
 - reading 94

T-W

- time
 - setting 51
- timers 67
 - addresses 28, 57, 59
 - calendar timers 74
 - comparing values 79
 - flashing pulse timer 67
 - OFF delay timer 67
 - ON delay timer 67
 - one-shot pulse timer 67
 - weekly timers 72
- trigger input 67
- troubleshooting 102
- weekly timers 72
- wiring 33
 - I/O 53
- work bits 27

Revision History

A manual revision code appears as a suffix to the catalog number on the front cover of the manual.

Cat. No. Z183-E1-01



The following table outlines the changes made to the manual during each revision. Page numbers refer to the previous version.

Revision code	Date	Revised content
01	May 2003	Original production



OMRON ELECTRONICS LLC

1 Commerce Drive
Schaumburg, IL 60173
847.843.7900
For US technical support or
other inquiries: 800.556.6766

OMRON CANADA, INC.

885 Milner Avenue
Toronto, Ontario M1B 5V8
416.286.6465

OMRON ON-LINE

Global - <http://www.omron.com>
USA - <http://www.omron.com/oei>
Canada - <http://www.omron.ca>

UNITED STATES

To locate a Regional Sales Office, local Distributor or
to obtain product information, call: 847.843.7900

CANADA REGIONAL SALES OFFICES

Ontario	Toronto	416.286.6465
	Kitchener	519.896.1144
	Kingston	613.376.3968
Quebec	Montreal	514.636.6676
British Columbia	Vancouver	604.522.8855
Alberta	Edmonton	403.440.0818
	Calgary	403.257.3095

BRAZIL SALES OFFICE

Sao Paulo 55.11.5564.6488

ARGENTINA SALES OFFICE

Cono Sur 54.114.787.1129

MEXICO SALES OFFICES

Florida 954.227.2121 **Ciudad Juarez** 656.623.7083
Mexico, D.F. 555.534.1195 **Monterrey, N.L.** 818.377.4281