

www.wackergroup.com

0160486en	001
1005	en

## Mobile Generators

**G 25**

**G 50**

**G 70**

**G 85**

**G 125**

**G 160**

**REPAIR MANUAL**



0 1 6 0 4 8 6 E N



This manual covers machines with Item Number:

**0009258, 0009259, 0009260, 0009261, 0009305, 0009306, 0009310,  
0009462, 0009463, 0009464, 0009465, 0009476, 0009477, 0009478**

### **Operating / Parts Information**

You must be familiar with the operation of this machine before you attempt to troubleshoot or repair it. Basic operating and maintenance procedures are described in the Operator's Manual supplied with the machine. Keep a copy of the Operator's Manual with the machine at all times. Use the separate Parts Book supplied with the machine to order replacement parts. If you are missing either of the documents, please contact Wacker Corporation to order a replacement.

Damage caused by misuse or neglect of the unit should be brought to the attention of the operator, to prevent similar occurrences from happening in the future.

This manual provides information and procedures to safely repair and maintain the above Wacker model(s). For your own safety and protection from injury, carefully read, understand, and observe all instructions described in this manual. THE INFORMATION CONTAINED IN THIS MANUAL IS BASED ON MACHINES MANUFACTURED UP TO THE TIME OF PUBLICATION. WACKER CORPORATION RESERVES THE RIGHT TO CHANGE ANY PORTION OF THIS INFORMATION WITHOUT NOTICE.

**CALIFORNIA****Proposition 65 Warning:**

Diesel engine exhaust, some of its constituents, and certain vehicle components contain or emit chemicals known to the State of California to cause cancer and birth defects or other reproductive harm.

**Laws Pertaining to Spark Arresters**

**Notice:** State Health Safety Codes and Public Resources Codes specify that in certain locations spark arresters be used on internal combustion engines that use hydrocarbon fuels. A spark arrester is a device designed to prevent accidental discharge of sparks or flames from the engine exhaust. Spark arresters are qualified and rated by the United States Forest Service for this purpose.

In order to comply with local laws regarding spark arresters, consult the engine distributor or the local Health and Safety Administrator.

All rights, especially copying and distribution rights, are reserved.

Copyright 2005 by Wacker Corporation

No part of this publication may be reproduced in any form or by any means, electronic or mechanical, including photocopying, without express written permission from Wacker Corporation.

Any type of reproduction or distribution not authorized by Wacker Corporation represents an infringement of valid copyrights and violators will be prosecuted. We expressly reserve the right to make technical modifications, even without due notice, which aim at improving our machines or their safety standards.

<b>1.</b>	<b>Safety Information</b>	<b>8</b>
1.1	Operating Safety .....	9
1.2	Service Safety .....	10
1.3	Operator Safety while using Internal Combustion Engines .....	12
1.4	Towing Safety .....	13
1.5	Reporting Trailer Safety Defects .....	13
1.6	Label Locations .....	14
1.7	Safety and Operating Labels .....	16
1.8	Calling for Service .....	21
<b>2.</b>	<b>Technical Data</b>	<b>23</b>
2.1	Engine Data—G 25 .....	23
2.2	Generator Data—G 25 .....	24
2.3	Trailer and Skid Data—G 25 .....	25
2.4	Dimensions—G 25 .....	25
2.5	Engine Data—G 50, G 70, G 85 .....	26
2.6	Generator Data—G 50, G 70, G 85 .....	27
2.7	Trailer Technical Data—G 50, G 70, G 85 .....	28
2.8	Dimensions—G 50, G 70, G 85 .....	29
2.9	Engine Data—G 125, G 160 .....	30
2.10	Generator Data—G 125, G 160 .....	31
2.11	Trailer Technical Data—G 125, G 160 .....	32
2.12	Dimensions—G 125, G 160 .....	32
2.13	Isuzu Engine Performance Data .....	33
2.14	John Deere Engine Performance .....	34
<b>3.</b>	<b>Maintenance</b>	<b>36</b>
3.1	Periodic Maintenance Schedule .....	36
3.2	Resetting the Periodic Maintenance Timer .....	37
3.3	Air Cleaner .....	37
3.4	Engine Lubrication .....	38
3.5	Engine Coolant .....	39
3.6	Trailer Maintenance .....	39
3.7	Trailer Wiring—G 25, G 50, G 70, G 85 .....	40
3.8	Trailer Wiring—G 125, G 160 .....	42

<b>4.</b>	<b>Theory of Operation</b>	<b>45</b>
4.1	Introduction .....	45
4.2	Basic Generator Schematic .....	46
4.3	Generator Components .....	47
4.4	Wiring Diagrams .....	48
4.5	Generator Systems .....	52
4.6	Power Generation & Output .....	53
4.7	Voltage Regulation .....	57
4.8	Engine Start .....	61
4.9	ECM Monitoring System .....	63
<b>5.</b>	<b>ECM Troubleshooting</b>	<b>66</b>
5.1	Normal Boot-up Sequence .....	66
5.2	Display Variables and Values .....	69
5.3	ECM Display Screens—Start Switch in Remote Position .....	70
5.4	Additional Variables Monitored by the ECM .....	71
5.5	CAN Bus Code Screen .....	77
5.6	Voltage Display Errors .....	78
5.7	ECM Automatic Engine Shutdown Conditions .....	80
5.8	Sender Failures .....	88
5.9	Recalibrating the ECM .....	88
5.10	Removing and Installing the ECM .....	93
5.11	ECM Circuit Boards .....	94
5.12	Control Wiring Numbering & Colors .....	95
5.13	Sender Resistance Graphs .....	98
5.14	Checking Magnetic Pickup .....	100
<b>6.</b>	<b>Isuzu Engine Troubleshooting</b>	<b>101</b>
6.1	Isuzu Engine Background .....	101
6.2	Engine Wiring Diagram—Isuzu .....	102
6.3	Engine Wiring Components—Isuzu .....	103
6.4	Engine Electrical Component Locations—Isuzu .....	104
6.5	Engine Electrical Components—Isuzu .....	105
6.6	Troubleshooting Flowcharts .....	105
6.7	Engine Troubleshooting—Isuzu .....	106
6.8	Checking Wire Continuity .....	109

6.9	Probing Plugs and Pins .....	109
6.10	Checking ECM Display and LEDs .....	110
6.11	Checking Battery .....	111
6.12	Checking Power to ECM .....	112
6.13	Checking Contacts of ECM Crank Relay .....	114
6.14	Checking ECM 10A Fuse .....	115
6.15	Checking Coil of Starter Relay and Wiring .....	116
6.16	Checking Diode Across Relay/Solenoid Coil .....	117
6.17	Checking Contacts of Starter Relay .....	118
6.18	Engine Cranks But Does Not Start—Isuzu .....	119
6.19	Checking Power to Glow Plugs .....	124
6.20	Checking Glow Plugs .....	125
6.21	Checking Glow Plug Relay and Wiring .....	126
6.22	Checking Contacts of ECM Preheat Relay .....	127
6.23	Checking Power to and Operation of Fuel Pump .....	128
6.24	Isuzu Fuel Solenoid .....	130
6.25	Checking Fuel Solenoid .....	132
6.26	Checking Coil of Fuel Pump Relay .....	134
6.27	Checking Contacts of ECM Fuel Relay .....	136
6.28	Checking Contacts of Fuel Pump Relay .....	137
6.29	General Engine Troubleshooting—Isuzu .....	138
<b>7.</b>	<b>John Deere Engines without ECU</b> .....	<b>143</b>
7.1	John Deere Engine Background .....	143
7.2	Engine Wiring Diagram—John Deere without ECU .....	144
7.3	Engine Wiring Components—John Deere without ECU .....	145
7.4	Locations of Engine Electrical Components .....	146
7.5	Engine Electrical Components .....	147
7.6	Troubleshooting Flowcharts .....	147
7.7	Engine Troubleshooting—John Deere without ECU .....	148
7.8	Checking Wiring Continuity .....	151
7.9	Probing Plugs and Pins .....	151
7.10	Checking ECM Display and LEDs .....	152
7.11	Checking Battery .....	153
7.12	Checking Power to ECM .....	154
7.13	Checking Contacts of ECM Crank Relay .....	156
7.14	Checking ECM 10A Fuse .....	157
7.15	Checking Diode Across Relay/Solenoid Coil .....	158
7.16	Checking Coil of Starter Relay and Wiring .....	160
7.17	Checking Contacts of Starter Relay and Wiring .....	161

7.18 Engine Cranks But Does Not Start ..... 162  
 7.19 Checking Contacts of ECM Preheat Relay ..... 165  
 7.20 Checking Slave Preheat Relay and Wiring ..... 166  
 7.21 Checking Manifold Heater ..... 167  
 7.22 Checking Fuel Circuit ..... 168  
 7.23 General Engine Troubleshooting—John Deere ..... 170

**8. John Deere Engines with ECU 175**

8.1 John Deere Engine Background ..... 175  
 8.2 Engine Wiring Diagram—John Deere with ECU ..... 176  
 8.3 Engine Wiring Components—John Deere with ECU ..... 177  
 8.4 ECU Wiring Diagram ..... 178  
 8.5 ECU Harness Connector ..... 179  
 8.6 Sensors and Components ..... 179  
 8.7 Locations of Engine Electrical Components ..... 180  
 8.8 Engine Electrical Components ..... 181  
 8.9 Troubleshooting Flowcharts ..... 181  
 8.10 Engine Troubleshooting—John Deere with ECU ..... 182  
 8.11 Checking Wiring Continuity ..... 185  
 8.12 Probing Plugs and Pins ..... 185  
 8.13 Checking ECM Display and LEDs ..... 186  
 8.14 Checking System 10A & 30A Fuses ..... 187  
 8.15 Checking Battery ..... 187  
 8.16 Checking Power to ECM and Start Switch ..... 188  
 8.17 Checking Contacts of ECM Crank Relay ..... 190  
 8.18 Checking ECM 10A Fuse ..... 191  
 8.19 Checking Relay Coil Diodes ..... 192  
 8.20 Checking Coil of Starter Relay and Wiring ..... 194  
 8.21 Checking Contacts of Starter Relay and Wiring ..... 196  
 8.22 Engine Cranks But Does Not Start—John Deere with ECU ..... 197  
 8.23 Checking Slave Preheat Relay and Wiring ..... 199  
 8.24 Checking Manifold Heater ..... 200  
 8.25 Checking Contacts of ECM Fuel Relay ..... 201  
 8.26 Checking Power to ECU ..... 202  
 8.27 General Engine Troubleshooting—John Deere with ECU ..... 204

<b>9.</b>	<b>Output Voltage Troubleshooting</b>	<b>208</b>
9.1	Wiring Diagrams .....	208
9.2	“No” Voltage Troubleshooting .....	214
9.3	Checking Main Circuit Breaker .....	217
9.4	Checking Circuit Breaker and Function of Voltage Selector Switch .	218
9.5	Replacing Voltage Selector Switch (VSS) .....	220
9.6	Checking Exciter Stator Winding .....	222
9.7	Accessing the Rotor Bearing, Diodes, and Rotor Winding .....	223
9.8	Checking Generator/Excitation System .....	224
9.9	Checking Lug Door Switch .....	228
9.10	Replacing and Resetting the Automatic Voltage Regulator (AVR) ...	230
9.11	Checking Exciter Rotor Winding .....	232
9.12	Checking Rectifier Diodes .....	233
9.13	Checking Main Rotor Winding .....	234
9.14	Replacing Rotor Bearing, Diode Ring, and Exciter Rotor .....	236
9.15	Low* Voltage Troubleshooting .....	238
9.16	Verifying Voltage .....	241
9.17	Checking Main Stator Winding .....	242
9.18	Generator Produces High Voltage Troubleshooting .....	243
9.19	Replacing Emergency Stop Switch .....	245
<b>10.</b>	<b>Disassembly/Assembly Procedures</b>	<b>247</b>
10.1	Tools .....	247
10.2	Ordering Parts .....	247
10.3	Reference Numbers ( ) .....	247
10.4	Weight Block .....	247
10.5	Exhaust System Exploded View—G 25 .....	248
10.6	Removing Exhaust System—G 25 .....	249
10.7	Installing Exhaust System—G 25 .....	249
10.8	Exhaust System Exploded View—G 50, G 70, G 85 .....	250
10.9	Removing Exhaust System—G 50, G 70, G 85 .....	251
10.10	Installing Exhaust System—G 50, G 70, G 85 .....	252
10.11	Exhaust System Exploded View—G 125, G 160 .....	253
10.12	Removing Exhaust System—G 125, G 160 .....	253
10.13	Installing Exhaust System—G 125, G 160 .....	254
10.14	Preparing Unit for Generator Removal .....	255
10.15	Removing Generator .....	256
10.16	Installing Generator .....	257
10.17	Removing Roof and Center Support Brackets .....	258

10.18	Installing Roof and Center Support Brackets .....	259
10.19	Preparing Unit for Engine/Generator Removal .....	260
10.20	Removing Engine/Generator Assembly .....	262
10.21	Installing Engine/Generator Assembly .....	263
10.22	Replacing Fuel Tank .....	264

## **11. Factory-Installed Options 266**

11.1	Block Heater .....	266
11.2	Fuel/Water Separator .....	267
11.3	Electronic Governor .....	268
11.4	Schematic—Isuzu Engine with Electronic Governor .....	270
11.5	Components—Isuzu Engine with Electronic Governor .....	271
11.6	Schematic—John Deere Engine with Electronic Governor .....	272
11.7	Components—John Deere Engine with Electronic Governor .....	273
11.8	LCD Strip Heater .....	274
11.9	Low Coolant Shutdown .....	275
11.10	Lube Level Maintainer .....	276
11.11	Temperature-Activated Shutters .....	277
11.12	Schematic—Temperature-Activated Shutters .....	278
11.13	Components—Temperature-Activated Shutters .....	279



## 1. Safety Information

This manual contains DANGER, WARNING, CAUTION, and NOTE callouts which must be followed to reduce the possibility of personal injury, damage to the equipment, or improper service.



This is the safety alert symbol. It is used to alert you to potential personal injury hazards. Obey all safety messages that follow this symbol to avoid possible injury or death.



**DANGER**

DANGER indicates an imminently hazardous situation which, if not avoided, will result in death or serious injury.



**WARNING**

WARNING indicates a potentially hazardous situation which, if not avoided, could result in death or serious injury.



**CAUTION**

CAUTION indicates a potentially hazardous situation which, if not avoided, may result in minor or moderate injury.

**CAUTION:** Used without the safety alert symbol, CAUTION indicates a potentially hazardous situation which, if not avoided, may result in property damage.

**Note:** *Contains additional information important to a procedure.*



**DANGER**

### **Danger of Electrocutation!**

Danger of electrocution or severe electrical shock is present throughout the generator any time the engine is running! Read all safety notes contained in this section before operating or servicing this equipment.

No one except a trained electrician, familiar with this equipment, should attempt repairs to the generator! Test procedures which require that the generator be running must be performed using extreme caution.

This machine is built with user safety in mind; however, like any electrical device it can present serious hazards if improperly operated and serviced. Follow instructions carefully! Should questions arise during operation or service of this equipment, contact Wacker Corporation.

## 1.1 Operating Safety

**WARNING**

Familiarity and proper training are required for the safe operation of equipment. Equipment operated improperly or by untrained personnel can be dangerous. Read the operating instructions contained in both this manual and the engine manual and familiarize yourself with the location and proper use of all controls. Inexperienced operators should receive instruction from someone familiar with the equipment before being allowed to operate the machine.

- 1.1.1 NEVER operate generator when open containers of fuel, paint, or other flammable liquids are near.
- 1.1.2 NEVER place flammable material or liquids near the generator.
- 1.1.3 NEVER operate generator, or tools attached to the generator, with wet hands.
- 1.1.4 NEVER use worn electrical cords. Severe electrical shock and equipment damage may result.
- 1.1.5 NEVER operate the machine indoors unless exhaust fumes can be adequately ventilated.
- 1.1.6 NEVER overload generator. The total amperage of the tools and equipment attached to the generator must not exceed the load rating of the generator.
- 1.1.7 NEVER allow untrained personnel to operate or service the generator. The generator set should be set up by a trained electrician.
- 1.1.8 NEVER operate generator in standing water.
- 1.1.9 NEVER touch the hot engine, exhaust, or generator components. Burns will result.
- 1.1.10 NEVER start a unit in need of repair.
- 1.1.11 Use the emergency stop button only in an actual emergency. DO NOT restart the engine until the cause of the trouble has been determined and fixed.
- 1.1.12 ALWAYS wear hearing protection when operating equipment.
- 1.1.13 ALWAYS follow starting and stopping instructions described in this manual. Know how to operate and stop generator before starting it.
- 1.1.14 ALWAYS make a walk-around inspection of the generator set before starting it. Open side doors and visually inspect engine compartment for obvious damage or the presence of foreign objects which might affect operation.
- 1.1.15 ALWAYS keep machine at least one meter (three feet) away from structures, buildings and other equipment during use.
- 1.1.16 ALWAYS store equipment properly when it is not being used. Equipment should be stored in a clean, dry location out of the reach of children.

- 1.1.17 ALWAYS keep the area immediately surrounding and underneath the machine clean, neat, and free of debris and combustible materials. Make sure that the area overhead is clear of debris that could fall onto or into the machine or exhaust compartment.
- 1.1.18 ALWAYS be sure the machine is on a firm, level surface and will not tip, roll, slide, or fall while operating.
- 1.1.19 ALWAYS remove all tools, cords, and other loose items from generator before starting it.
- 1.1.20 ALWAYS make certain the machine is well-grounded and securely fastened to a good earthen ground per national and local regulations.



**BACKFEED FROM THE GENERATOR INTO THE PUBLIC POWER DISTRIBUTION SYSTEM CAN CAUSE SERIOUS INJURY OR DEATH TO UTILITY WORKERS!**

Improper connection of generator to a building's electrical system can allow electrical current from the generator to backfeed into utility lines. This may result in electrocution of utility workers, fire, or explosion. Connections to a building's electrical system must be made by a qualified electrician and comply with all applicable laws and electrical codes.

If connected to a building's electrical system the generator must meet the power, voltage, and frequency requirements of the equipment in the building. Differences in power, voltage, and frequency requirements may exist and improper connection may lead to equipment damage, fire, and personal injury or death.

## 1.2 Service Safety



Poorly maintained equipment can become a safety hazard! In order for the equipment to operate safely and properly over a long period of time, periodic maintenance and occasional repairs are necessary.

- 1.2.1 **NEVER perform even routine service (oil/filter changes, cleaning, etc.) unless all electrical components are shut down.** Before servicing this machine, make sure the engine start switch is turned to off "O", the circuit breakers are open (off), the emergency stop switch is closed (pushed in), and the negative terminal on battery is disconnected. Attach a "DO NOT START" sign to the control panel. This will notify everyone that the unit is being serviced and will reduce the chance of someone inadvertently trying to start the unit. If the unit is connected to a remote start or transfer switch, make sure the remote switch is also off and tagged.

### 1.2.2 Ground Connection

**The generator must be connected to a good earthen ground for proper operating safety!**

A central “equipment ground” is provided at the customer connection lugs. This point is connected directly to the generator set base. All other system grounds are connected to this central point. Ground the generator in accordance with the standards defined in national, state and local regulations.

- 1.2.3 DO NOT attempt to open the radiator cap while the unit is running or before the engine has cooled down. Severe burns may result!
- 1.2.4 DO NOT allow water to accumulate around the base of the machine. If water is present, move the machine and allow the machine to dry before servicing.
- 1.2.5 DO NOT service the machine if clothing or skin is wet.
- 1.2.6 DO NOT allow untrained personnel to service this equipment. Only trained electrical technicians should be allowed to service the electrical components of this equipment.
- 1.2.7 DO NOT modify the equipment without express written approval of the manufacturer.
- 1.2.8 When cleaning the unit, DO NOT pressure wash the control panel, generator end, or any other electrical components. Never allow water to accumulate around the base of the generator set. If water is present, DO NOT service!
- 1.2.9 ALWAYS replace the safety devices and guards after repairs and maintenance.
- 1.2.10 ALWAYS let engine cool before transporting or servicing.
- 1.2.11 ALWAYS remain aware of moving parts and keep hands, feet, and loose clothing away from moving parts of equipment.
- 1.2.12 ALWAYS replace all guards, fasten doors and make sure all safety devices operate properly after making repairs or servicing the equipment.
- 1.2.13 ALWAYS keep hands, feet, and loose clothing away from moving parts on generator and engine.
- 1.2.14 ALWAYS keep the machine clean and labels legible. Replace all missing and hard-to-read labels. Labels provide important operating instructions and warn of dangers and hazards.
- 1.2.15 ALWAYS check and tighten all external fasteners at regular intervals.
- 1.2.16 ALWAYS make sure slings, chains, hooks, ramps, jacks and other types of lifting devices are attached securely and have enough weight-bearing capacity to lift or hold the machine safely. Always remain aware of the location of other people around when lifting the machine.

### 1.3 Operator Safety while using Internal Combustion Engines



**DANGER**

Internal combustion engines present special hazards during operation and fueling. Read and follow the warning instructions in the engine owner's manual and the safety guidelines below. Failure to follow the warnings and safety guidelines could result in severe injury or death.

- 1.3.1 DO NOT run engine indoors or in an area with poor ventilation unless exhaust hoses are used.
- 1.3.2 DO NOT fill or drain the fuel tank near an open flame, while smoking, or while the engine is running.
- 1.3.3 DO NOT refuel a hot or running engine.
- 1.3.4 ALWAYS refill the fuel tank in a well-ventilated area.
- 1.3.5 DO NOT touch or lean against hot exhaust pipes.
- 1.3.6 ALWAYS replace the fuel tank cap after refueling.
- 1.3.7 DO NOT start engine if fuel has spilled or an odor of fuel is present. Move generator away from the spill and wipe generator dry before starting.
- 1.3.8 DO NOT remove radiator cap when the engine is hot. The radiator fluid is hot and under pressure and may cause severe burns!

## 1.4 Towing Safety



Towing a large trailer requires special care. Both the trailer and vehicle must be in good condition and securely fastened to each other to reduce the possibility of an accident.

- 1.4.1 ALWAYS check that the hitch and coupling on the vehicle are rated equal to, or greater than, the trailer's "gross vehicle weight rating" (GVWR).
- 1.4.2 ALWAYS inspect the hitch and coupling for wear or damage. DO NOT tow trailer using defective parts.
- 1.4.3 ALWAYS make sure the coupling is securely fastened to the vehicle.
- 1.4.4 ALWAYS check the tires on the trailer for tread wear, inflation, and condition. Replace worn tires.
- 1.4.5 ALWAYS connect the safety chains.
- 1.4.6 ALWAYS connect breakaway cable safety hook to the bumper or rear of the vehicle. DO NOT attach to hitch.
- 1.4.7 ALWAYS test surge brakes on trailer and the brakes on vehicle that will be used for towing.
- 1.4.8 ALWAYS make sure directional and trailer lights are connected and working properly.
- 1.4.9 ALWAYS check that the lug nuts holding the wheels are tight and that none are missing.

## 1.5 Reporting Trailer Safety Defects

If you believe your trailer has a defect which could cause a crash or could cause injury or death, you should immediately inform the National Highway Traffic Safety Administration (NHTSA) in addition to notifying WACKER Corporation.

If NHTSA receives similar complaints, it may open an investigation; and if it finds that a safety defect exists in a group of vehicles, it may order a recall and remedy campaign. However, NHTSA cannot become involved in individual problems between you, your dealer, or WACKER Corporation.

To contact NHTSA, you may either contact the Auto Safety Hotline toll-free at 1-800-424-9393 (or 366-0129 in Washington DC area), [www.nhtsa.com](http://www.nhtsa.com), or write to NHTSA, U.S. Department of Transportation, Washington, DC 20590. You can also obtain other information about motor vehicle safety from the Hotline.

1.6 Label Locations

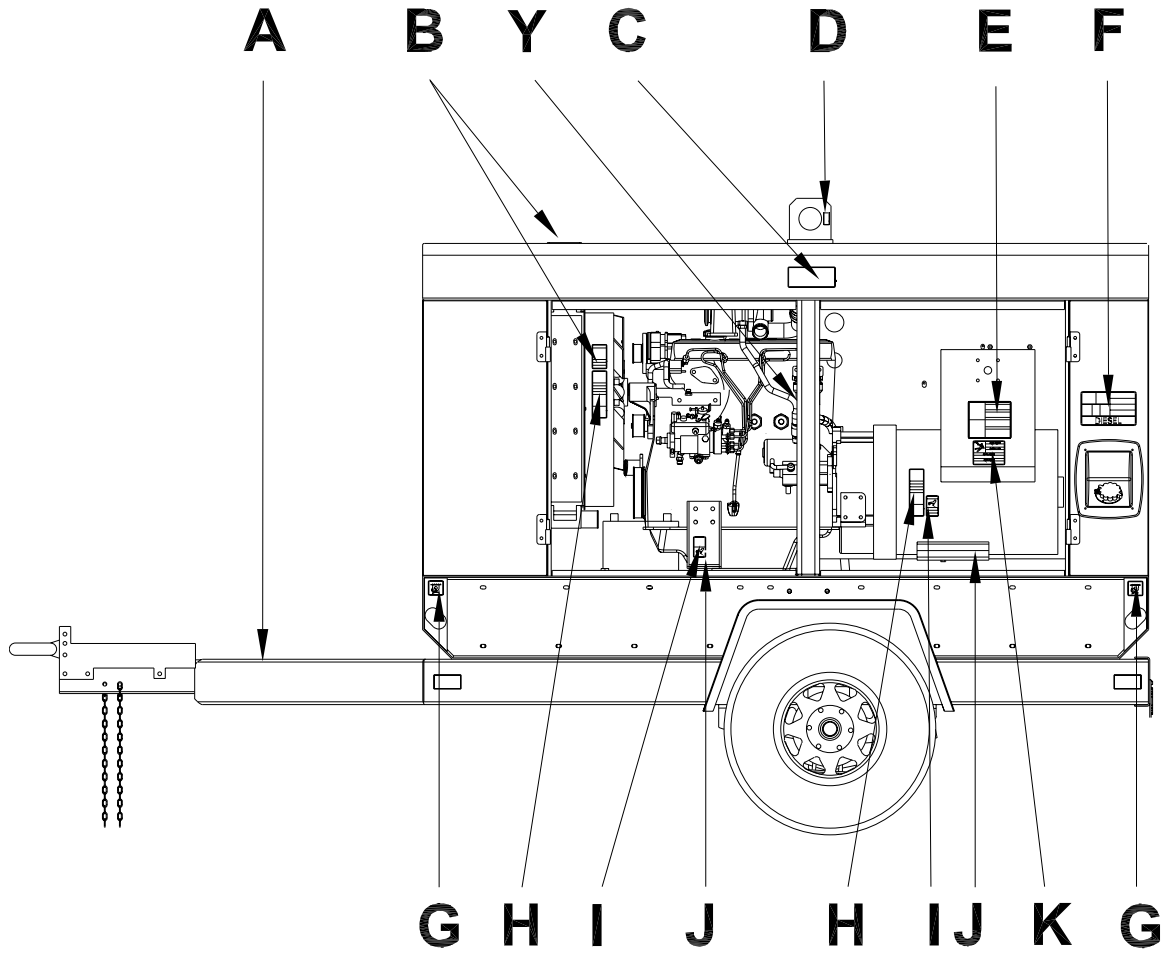



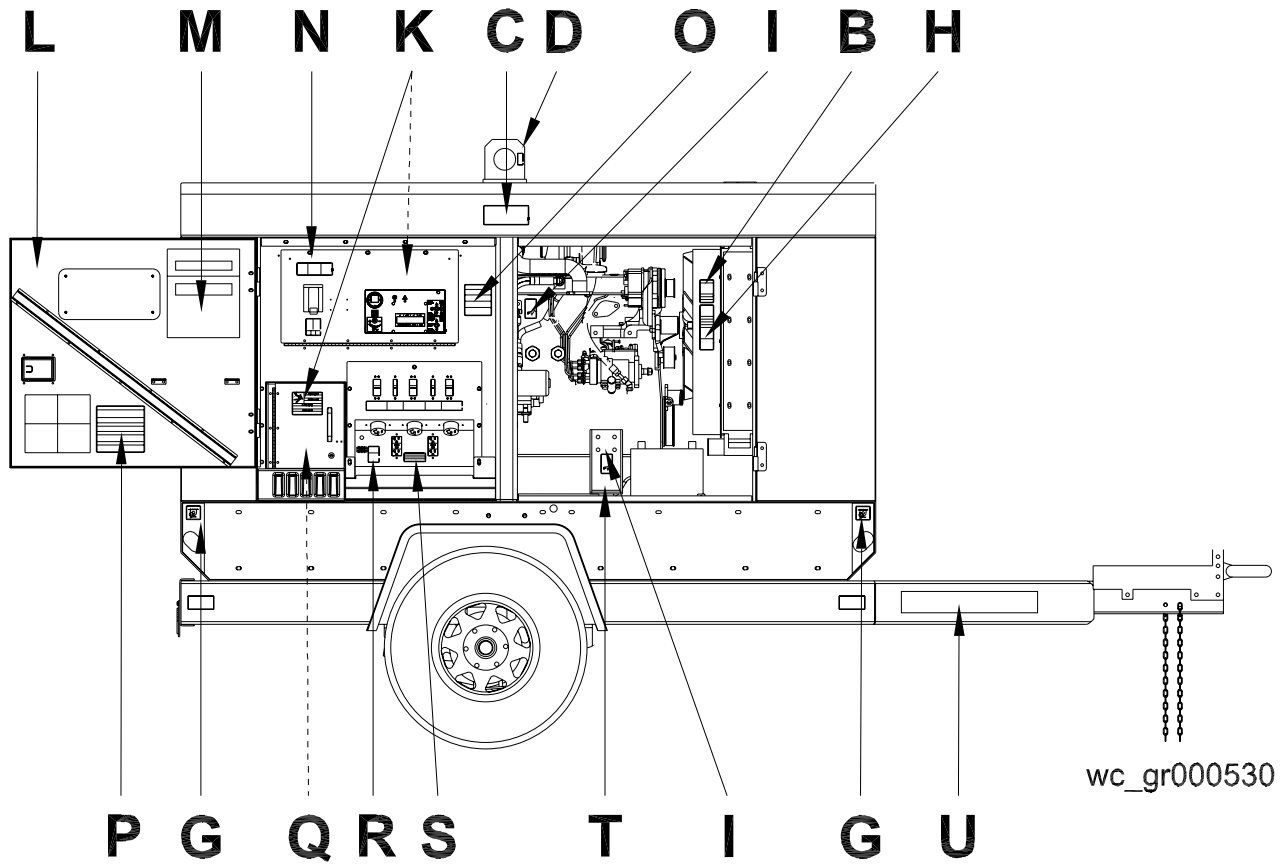

wc\_gr000528





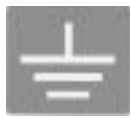



## 1.7 Safety and Operating Labels

Ref.	Label	Meaning								
A	<table border="1"> <thead> <tr> <th>TOWING INSTRUCTIONS</th> <th>ABSCHLEPPINSTRUKTIONEN</th> <th>INSTRUCCIONES DE REMOLQUE</th> <th>INSTRUCCIONES DE REMORQUAGE</th> </tr> </thead> <tbody> <tr> <td>                     1. READ OPERATOR'S MANUAL.                      2. USE HITCH RATED PRO TRAILER'S "GROSS VEHICLE WEIGHT RATING".                      3. SECURELY ATTACH TRAILER TO TOW VEHICLE.                      4. ATTACH SAFETY CHAINS USING CROSS PATTERN.                      5. ATTACH BREAKDOWN CHAIN TO VEHICLE.                      6. CHECK TRAILER LIGHTS.                 </td> <td>                     1. BETRIEBSVORSCHRIFT LESEN.                      2. ANHANGEVORRICHTUNG VERWENDEN, DIE DER GESAMTBETRIEBSGEWICHTSKLASSE ENTSPICHT.                      3. ANHANGER SICHER AM ZUGFAHRZEUG BEFESTIGEN.                      4. SICHERHEITSKETTEN KREUZWEISE ANBRINGEN.                      5. ABREISSKETTE AM FAHRZEUG ANBRINGEN.                      6. ANHANGERLEUCHTEN PRÜFEN.                 </td> <td>                     1. LEA EL MANUAL DEL OPERARIO.                      2. UTILICE UN ACOPLER CORRECTAMENTE CLASIFICADO PARA LA "CLASE DE PESO BUTO" DEL VEHICULO DEL REMOLQUE.                      3. ASEGURESE DE AMARRAR CORRECTAMENTE EL REMOLQUE AL VEHICULO DE REMOLQUE.                      4. FIJE EN CRUZ LAS CADENAS DE SEGURIDAD.                      5. FIJE EN EL VEHICULO DE REMOLQUE LA CADENA DE DESPRENDIMIENTO.                      6. CONTROLE LAS LUCES DEL REMOLQUE.                 </td> <td>                     1. LIRE LA NOTICE D'EMPLOI.                      2. UTILISER UN GROCHET D'ATTACHE CONFORME AU DEBIT NOMINAL DU POIDS BRUT DE VEHICULE DU TRACTEUR.                      3. ATTACHER LA REMORQUE FERMEMENT AU VEHICULE TRACTEUR.                      4. ATTACHER LES CHAINES DE SURETTE EN UTILISANT UNE METHODE CROISEE.                      5. ATTACHER LA CHAÎNE DE REMORQUAGE AU VEHICULE.                      6. VERIFIER LES LAMPES DE LA REMORQUE.                 </td> </tr> </tbody> </table>	TOWING INSTRUCTIONS	ABSCHLEPPINSTRUKTIONEN	INSTRUCCIONES DE REMOLQUE	INSTRUCCIONES DE REMORQUAGE	1. READ OPERATOR'S MANUAL. 2. USE HITCH RATED PRO TRAILER'S "GROSS VEHICLE WEIGHT RATING". 3. SECURELY ATTACH TRAILER TO TOW VEHICLE. 4. ATTACH SAFETY CHAINS USING CROSS PATTERN. 5. ATTACH BREAKDOWN CHAIN TO VEHICLE. 6. CHECK TRAILER LIGHTS.	1. BETRIEBSVORSCHRIFT LESEN. 2. ANHANGEVORRICHTUNG VERWENDEN, DIE DER GESAMTBETRIEBSGEWICHTSKLASSE ENTSPICHT. 3. ANHANGER SICHER AM ZUGFAHRZEUG BEFESTIGEN. 4. SICHERHEITSKETTEN KREUZWEISE ANBRINGEN. 5. ABREISSKETTE AM FAHRZEUG ANBRINGEN. 6. ANHANGERLEUCHTEN PRÜFEN.	1. LEA EL MANUAL DEL OPERARIO. 2. UTILICE UN ACOPLER CORRECTAMENTE CLASIFICADO PARA LA "CLASE DE PESO BUTO" DEL VEHICULO DEL REMOLQUE. 3. ASEGURESE DE AMARRAR CORRECTAMENTE EL REMOLQUE AL VEHICULO DE REMOLQUE. 4. FIJE EN CRUZ LAS CADENAS DE SEGURIDAD. 5. FIJE EN EL VEHICULO DE REMOLQUE LA CADENA DE DESPRENDIMIENTO. 6. CONTROLE LAS LUCES DEL REMOLQUE.	1. LIRE LA NOTICE D'EMPLOI. 2. UTILISER UN GROCHET D'ATTACHE CONFORME AU DEBIT NOMINAL DU POIDS BRUT DE VEHICULE DU TRACTEUR. 3. ATTACHER LA REMORQUE FERMEMENT AU VEHICULE TRACTEUR. 4. ATTACHER LES CHAINES DE SURETTE EN UTILISANT UNE METHODE CROISEE. 5. ATTACHER LA CHAÎNE DE REMORQUAGE AU VEHICULE. 6. VERIFIER LES LAMPES DE LA REMORQUE.	
TOWING INSTRUCTIONS	ABSCHLEPPINSTRUKTIONEN	INSTRUCCIONES DE REMOLQUE	INSTRUCCIONES DE REMORQUAGE							
1. READ OPERATOR'S MANUAL. 2. USE HITCH RATED PRO TRAILER'S "GROSS VEHICLE WEIGHT RATING". 3. SECURELY ATTACH TRAILER TO TOW VEHICLE. 4. ATTACH SAFETY CHAINS USING CROSS PATTERN. 5. ATTACH BREAKDOWN CHAIN TO VEHICLE. 6. CHECK TRAILER LIGHTS.	1. BETRIEBSVORSCHRIFT LESEN. 2. ANHANGEVORRICHTUNG VERWENDEN, DIE DER GESAMTBETRIEBSGEWICHTSKLASSE ENTSPICHT. 3. ANHANGER SICHER AM ZUGFAHRZEUG BEFESTIGEN. 4. SICHERHEITSKETTEN KREUZWEISE ANBRINGEN. 5. ABREISSKETTE AM FAHRZEUG ANBRINGEN. 6. ANHANGERLEUCHTEN PRÜFEN.	1. LEA EL MANUAL DEL OPERARIO. 2. UTILICE UN ACOPLER CORRECTAMENTE CLASIFICADO PARA LA "CLASE DE PESO BUTO" DEL VEHICULO DEL REMOLQUE. 3. ASEGURESE DE AMARRAR CORRECTAMENTE EL REMOLQUE AL VEHICULO DE REMOLQUE. 4. FIJE EN CRUZ LAS CADENAS DE SEGURIDAD. 5. FIJE EN EL VEHICULO DE REMOLQUE LA CADENA DE DESPRENDIMIENTO. 6. CONTROLE LAS LUCES DEL REMOLQUE.	1. LIRE LA NOTICE D'EMPLOI. 2. UTILISER UN GROCHET D'ATTACHE CONFORME AU DEBIT NOMINAL DU POIDS BRUT DE VEHICULE DU TRACTEUR. 3. ATTACHER LA REMORQUE FERMEMENT AU VEHICULE TRACTEUR. 4. ATTACHER LES CHAINES DE SURETTE EN UTILISANT UNE METHODE CROISEE. 5. ATTACHER LA CHAÎNE DE REMORQUAGE AU VEHICULE. 6. VERIFIER LES LAMPES DE LA REMORQUE.							
B		<p><b>WARNING!</b>                  Pressurized contents. Do not open when hot!</p>								
C		<p><b>WARNING!</b>                  Lock doors. Access can cause electric shock or injury.</p>								
D		<p><b>CAUTION!</b>                  Lifting point</p>								
E		<p><b>CAUTION!</b>                  Never change switch position with engine running. Results in damage to machine.</p>								
F		<p><b>DANGER!</b>                  Asphyxiation hazard. Read the Operator's Manual for instructions. No sparks, flames, or burning objects near machine. Stop the engine before adding fuel. Use only diesel fuel.</p>								

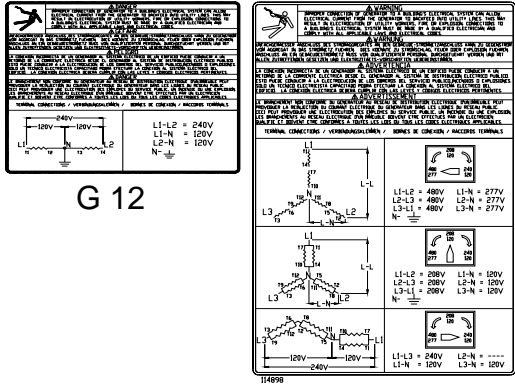
Ref.	Label	Meaning
G		Tie-down point
H		<p><b>WARNING!</b> To prevent hearing loss, wear hearing protection. Hand injury if entangled in moving belt. Rotating machinery! Do not reach inside with engine running.</p>
I		<p><b>WARNING!</b> Hot surface!</p>
J		Electrical ground.
K		<p><b>WARNING!</b> Electric shock will cause serious injury or death.</p>

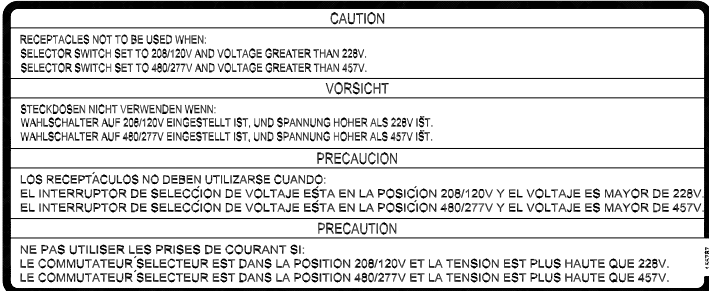
Ref.	Label	Meaning								
L	<table border="1" style="width: 100%; border-collapse: collapse;"> <thead> <tr> <th style="width: 50%;">OPERATING INSTRUCTIONS FOR MOBILE GENERATORS</th> <th style="width: 50%;">BETRIEBSANLEITUNG FÜR MOBILEAGGREGATE</th> </tr> </thead> <tbody> <tr> <td> <p><b>BEFORE STARTING</b></p> <ol style="list-style-type: none"> <li>1. READ OPERATOR'S MANUAL.</li> <li>2. LEVEL UNIT.</li> <li>3. BLOCK WHEELS.</li> <li>4. GROUND UNIT.</li> <li>5. CHECK ALL FLUID LEVELS.</li> </ol> <p><b>MANUAL STARTING</b></p> <ol style="list-style-type: none"> <li>1. DISCONNECT ALL EXTERNAL LOADS.</li> <li>2. SET VOLTAGE SELECTOR SWITCH.</li> <li>3. LOCK VOLTAGE SELECTOR SWITCH.</li> <li>4. TURN EMERGENCY STOP BUTTON TO "ON" POSITION.</li> <li>5. PUSH ENGINE START SWITCH TO "START/RUN" POSITION.</li> <li>6. ENGINE WILL MAKE 3 ATTEMPTS TO START.</li> </ol> <p><b>REMOTE START</b></p> <ol style="list-style-type: none"> <li>1. SEE OPERATOR'S MANUAL.</li> </ol> <p><b>STOPPING</b></p> <ol style="list-style-type: none"> <li>1. DISCONNECT ALL EXTERNAL LOADS.</li> <li>2. PUSH ENGINE START SWITCH TO "OFF" POSITION.</li> <li>3. FILL FUEL TANK.</li> </ol> </td> <td> <p><b>VOR DEM STARTEN</b></p> <ol style="list-style-type: none"> <li>1. BETRIEBSVORSCHRIFT LESEN.</li> <li>2. GERÄT WAAGRECHT STELLEN.</li> <li>3. RÄDER BLOCKIEREN.</li> <li>4. GERÄT ERDEN.</li> <li>5. STAND ALLER FLÜSSIGKEITEN PRÜFEN.</li> </ol> <p><b>HANDSTARTEN</b></p> <ol style="list-style-type: none"> <li>1. ALLE AUSSEREN BELASTUNGEN ABSCHALTEN.</li> <li>2. SPANNUNGSWAHLSCHALTER SETZEN.</li> <li>3. SPANNUNGSWAHLSCHALTER VERRIEGELN.</li> <li>4. NOTSTOPKNOPF IN "ON" POSITION SETZEN.</li> <li>5. MOTORSTARTSCHALTER AUF POSITION "START/LAUF" DRÜCKEN.</li> <li>6. MOTOR VOLLZIEHT 3 STARTVERSUCHE.</li> </ol> <p><b>FERNSTART</b></p> <ol style="list-style-type: none"> <li>1. SIEHE BETRIEBSVORSCHRIFT.</li> </ol> <p><b>ABSCHALTEN</b></p> <ol style="list-style-type: none"> <li>1. ALLE AUSSEREN BELASTUNGEN ABSCHALTEN.</li> <li>2. MOTORSTARTSCHALTER AUF POSITION "OFF" DRÜCKEN.</li> <li>3. KRAFTSTOFFTANK FÜLLEN.</li> </ol> </td> </tr> <tr> <th style="width: 50%;">INSTRUCCIONES PARA LA PUESTA EN MARCHA DE GENERADORES MOVILES</th> <th style="width: 50%;">INSTRUCTIONS D'OPERATION DU GENERATEUR MOBILE</th> </tr> <tr> <td> <p><b>ANTES DEL ARRANQUE</b></p> <ol style="list-style-type: none"> <li>1. LEA EL MANUAL DEL OPERARIO.</li> <li>2. NIVELE LA UNIDAD.</li> <li>3. COLOQUE CUNAS DEBAJO DE LAS RUEDAS.</li> <li>4. CONECTE LA UNIDAD A TIERRA.</li> <li>5. CONTROLE TODOS LOS LIQUIDOS.</li> </ol> <p><b>ARRANQUE MANUAL</b></p> <ol style="list-style-type: none"> <li>1. DESCONECTE TODAS LAS CARGAS EXTERNAS.</li> <li>2. AJUSTE LA LLAVE SELECTORA DE VOLTAJE.</li> <li>3. BLOQUEE LA LLAVE SELECTORA DE VOLTAJE.</li> <li>4. GIRE A LA POSICION "ON" EL BOTON DE PARADA DE EMERGENCIA.</li> <li>5. OPRIMA A LA POSICION "ARRANQUE/MARCHA" EL INTERRUPTOR DE ARRANQUE DEL MOTOR.</li> <li>6. EL MOTOR INTENTARA ARRANCAR 3 VECES.</li> </ol> <p><b>ARRANQUE REMOTO</b></p> <ol style="list-style-type: none"> <li>1. VEA EL MANUAL DEL OPERARIO.</li> </ol> <p><b>DETENCION DEL MOTOR</b></p> <ol style="list-style-type: none"> <li>1. DESCONECTE TODAS LAS CARGAS EXTERNAS.</li> <li>2. OPRIMA A LA POSICION "OFF" EL INTERRUPTOR DE ARRANQUE DEL MOTOR.</li> <li>3. LLENE EL TANQUE DE COMBUSTIBLE.</li> </ol> </td> <td> <p><b>AVANT LE DEMARRAGE</b></p> <ol style="list-style-type: none"> <li>1. LIRE LA NOTICE D'EMPLOI.</li> <li>2. NIVELER LA MACHINE.</li> <li>3. BLOQUER LES ROUES AVEC CALES DE ROUES.</li> <li>4. METTRE A TERRE LA MACHINE.</li> <li>5. VERIFIER LE NIVEAU DE TOUS LES FLUIDES.</li> </ol> <p><b>DEMARRAGE A LA MAIN</b></p> <ol style="list-style-type: none"> <li>1. DECONNECTER TOUS LES REGIMES EXTERNES.</li> <li>2. REGLER LE COMMUTEUR DES TENSIONS D'ALIMENTATION.</li> <li>3. SERRER LE COMMUTEUR DES TENSIONS D'ALIMENTATION.</li> <li>4. TOURNER LE BOUTON D'ARRET D'URGENCE A LA POSITION "ON".</li> <li>5. PRESSER L'INTERRUPTEUR DE DEMARRAGE DU MOTEUR A LA POSITION "DEMARRAGE/MARCHE".</li> <li>6. LE MOTEUR S'ESSAYERA DE DEMARRER 3 FOIS.</li> </ol> <p><b>DEMARRAGE A DISTANCE</b></p> <ol style="list-style-type: none"> <li>1. LIRE LA NOTICE D'EMPLOI.</li> </ol> <p><b>ARRET</b></p> <ol style="list-style-type: none"> <li>1. DECONNECTER TOUS LES REGIMES EXTERNES.</li> <li>2. PRESSER L'INTERRUPTEUR DE DEMARRAGE DU MOTEUR A LA POSITION "OFF".</li> <li>3. REMPLIR LE RESERVOIR A CARBURANT.</li> </ol> </td> </tr> </tbody> </table>	OPERATING INSTRUCTIONS FOR MOBILE GENERATORS	BETRIEBSANLEITUNG FÜR MOBILEAGGREGATE	<p><b>BEFORE STARTING</b></p> <ol style="list-style-type: none"> <li>1. READ OPERATOR'S MANUAL.</li> <li>2. LEVEL UNIT.</li> <li>3. BLOCK WHEELS.</li> <li>4. GROUND UNIT.</li> <li>5. CHECK ALL FLUID LEVELS.</li> </ol> <p><b>MANUAL STARTING</b></p> <ol style="list-style-type: none"> <li>1. DISCONNECT ALL EXTERNAL LOADS.</li> <li>2. SET VOLTAGE SELECTOR SWITCH.</li> <li>3. LOCK VOLTAGE SELECTOR SWITCH.</li> <li>4. TURN EMERGENCY STOP BUTTON TO "ON" POSITION.</li> <li>5. PUSH ENGINE START SWITCH TO "START/RUN" POSITION.</li> <li>6. ENGINE WILL MAKE 3 ATTEMPTS TO START.</li> </ol> <p><b>REMOTE START</b></p> <ol style="list-style-type: none"> <li>1. SEE OPERATOR'S MANUAL.</li> </ol> <p><b>STOPPING</b></p> <ol style="list-style-type: none"> <li>1. DISCONNECT ALL EXTERNAL LOADS.</li> <li>2. PUSH ENGINE START SWITCH TO "OFF" POSITION.</li> <li>3. FILL FUEL TANK.</li> </ol>	<p><b>VOR DEM STARTEN</b></p> <ol style="list-style-type: none"> <li>1. BETRIEBSVORSCHRIFT LESEN.</li> <li>2. GERÄT WAAGRECHT STELLEN.</li> <li>3. RÄDER BLOCKIEREN.</li> <li>4. GERÄT ERDEN.</li> <li>5. STAND ALLER FLÜSSIGKEITEN PRÜFEN.</li> </ol> <p><b>HANDSTARTEN</b></p> <ol style="list-style-type: none"> <li>1. ALLE AUSSEREN BELASTUNGEN ABSCHALTEN.</li> <li>2. SPANNUNGSWAHLSCHALTER SETZEN.</li> <li>3. SPANNUNGSWAHLSCHALTER VERRIEGELN.</li> <li>4. NOTSTOPKNOPF IN "ON" POSITION SETZEN.</li> <li>5. MOTORSTARTSCHALTER AUF POSITION "START/LAUF" DRÜCKEN.</li> <li>6. MOTOR VOLLZIEHT 3 STARTVERSUCHE.</li> </ol> <p><b>FERNSTART</b></p> <ol style="list-style-type: none"> <li>1. SIEHE BETRIEBSVORSCHRIFT.</li> </ol> <p><b>ABSCHALTEN</b></p> <ol style="list-style-type: none"> <li>1. ALLE AUSSEREN BELASTUNGEN ABSCHALTEN.</li> <li>2. MOTORSTARTSCHALTER AUF POSITION "OFF" DRÜCKEN.</li> <li>3. KRAFTSTOFFTANK FÜLLEN.</li> </ol>	INSTRUCCIONES PARA LA PUESTA EN MARCHA DE GENERADORES MOVILES	INSTRUCTIONS D'OPERATION DU GENERATEUR MOBILE	<p><b>ANTES DEL ARRANQUE</b></p> <ol style="list-style-type: none"> <li>1. LEA EL MANUAL DEL OPERARIO.</li> <li>2. NIVELE LA UNIDAD.</li> <li>3. COLOQUE CUNAS DEBAJO DE LAS RUEDAS.</li> <li>4. CONECTE LA UNIDAD A TIERRA.</li> <li>5. CONTROLE TODOS LOS LIQUIDOS.</li> </ol> <p><b>ARRANQUE MANUAL</b></p> <ol style="list-style-type: none"> <li>1. DESCONECTE TODAS LAS CARGAS EXTERNAS.</li> <li>2. AJUSTE LA LLAVE SELECTORA DE VOLTAJE.</li> <li>3. BLOQUEE LA LLAVE SELECTORA DE VOLTAJE.</li> <li>4. GIRE A LA POSICION "ON" EL BOTON DE PARADA DE EMERGENCIA.</li> <li>5. OPRIMA A LA POSICION "ARRANQUE/MARCHA" EL INTERRUPTOR DE ARRANQUE DEL MOTOR.</li> <li>6. EL MOTOR INTENTARA ARRANCAR 3 VECES.</li> </ol> <p><b>ARRANQUE REMOTO</b></p> <ol style="list-style-type: none"> <li>1. VEA EL MANUAL DEL OPERARIO.</li> </ol> <p><b>DETENCION DEL MOTOR</b></p> <ol style="list-style-type: none"> <li>1. DESCONECTE TODAS LAS CARGAS EXTERNAS.</li> <li>2. OPRIMA A LA POSICION "OFF" EL INTERRUPTOR DE ARRANQUE DEL MOTOR.</li> <li>3. LLENE EL TANQUE DE COMBUSTIBLE.</li> </ol>	<p><b>AVANT LE DEMARRAGE</b></p> <ol style="list-style-type: none"> <li>1. LIRE LA NOTICE D'EMPLOI.</li> <li>2. NIVELER LA MACHINE.</li> <li>3. BLOQUER LES ROUES AVEC CALES DE ROUES.</li> <li>4. METTRE A TERRE LA MACHINE.</li> <li>5. VERIFIER LE NIVEAU DE TOUS LES FLUIDES.</li> </ol> <p><b>DEMARRAGE A LA MAIN</b></p> <ol style="list-style-type: none"> <li>1. DECONNECTER TOUS LES REGIMES EXTERNES.</li> <li>2. REGLER LE COMMUTEUR DES TENSIONS D'ALIMENTATION.</li> <li>3. SERRER LE COMMUTEUR DES TENSIONS D'ALIMENTATION.</li> <li>4. TOURNER LE BOUTON D'ARRET D'URGENCE A LA POSITION "ON".</li> <li>5. PRESSER L'INTERRUPTEUR DE DEMARRAGE DU MOTEUR A LA POSITION "DEMARRAGE/MARCHE".</li> <li>6. LE MOTEUR S'ESSAYERA DE DEMARRER 3 FOIS.</li> </ol> <p><b>DEMARRAGE A DISTANCE</b></p> <ol style="list-style-type: none"> <li>1. LIRE LA NOTICE D'EMPLOI.</li> </ol> <p><b>ARRET</b></p> <ol style="list-style-type: none"> <li>1. DECONNECTER TOUS LES REGIMES EXTERNES.</li> <li>2. PRESSER L'INTERRUPTEUR DE DEMARRAGE DU MOTEUR A LA POSITION "OFF".</li> <li>3. REMPLIR LE RESERVOIR A CARBURANT.</li> </ol>	
OPERATING INSTRUCTIONS FOR MOBILE GENERATORS	BETRIEBSANLEITUNG FÜR MOBILEAGGREGATE									
<p><b>BEFORE STARTING</b></p> <ol style="list-style-type: none"> <li>1. READ OPERATOR'S MANUAL.</li> <li>2. LEVEL UNIT.</li> <li>3. BLOCK WHEELS.</li> <li>4. GROUND UNIT.</li> <li>5. CHECK ALL FLUID LEVELS.</li> </ol> <p><b>MANUAL STARTING</b></p> <ol style="list-style-type: none"> <li>1. DISCONNECT ALL EXTERNAL LOADS.</li> <li>2. SET VOLTAGE SELECTOR SWITCH.</li> <li>3. LOCK VOLTAGE SELECTOR SWITCH.</li> <li>4. TURN EMERGENCY STOP BUTTON TO "ON" POSITION.</li> <li>5. PUSH ENGINE START SWITCH TO "START/RUN" POSITION.</li> <li>6. ENGINE WILL MAKE 3 ATTEMPTS TO START.</li> </ol> <p><b>REMOTE START</b></p> <ol style="list-style-type: none"> <li>1. SEE OPERATOR'S MANUAL.</li> </ol> <p><b>STOPPING</b></p> <ol style="list-style-type: none"> <li>1. DISCONNECT ALL EXTERNAL LOADS.</li> <li>2. PUSH ENGINE START SWITCH TO "OFF" POSITION.</li> <li>3. FILL FUEL TANK.</li> </ol>	<p><b>VOR DEM STARTEN</b></p> <ol style="list-style-type: none"> <li>1. BETRIEBSVORSCHRIFT LESEN.</li> <li>2. GERÄT WAAGRECHT STELLEN.</li> <li>3. RÄDER BLOCKIEREN.</li> <li>4. GERÄT ERDEN.</li> <li>5. STAND ALLER FLÜSSIGKEITEN PRÜFEN.</li> </ol> <p><b>HANDSTARTEN</b></p> <ol style="list-style-type: none"> <li>1. ALLE AUSSEREN BELASTUNGEN ABSCHALTEN.</li> <li>2. SPANNUNGSWAHLSCHALTER SETZEN.</li> <li>3. SPANNUNGSWAHLSCHALTER VERRIEGELN.</li> <li>4. NOTSTOPKNOPF IN "ON" POSITION SETZEN.</li> <li>5. MOTORSTARTSCHALTER AUF POSITION "START/LAUF" DRÜCKEN.</li> <li>6. MOTOR VOLLZIEHT 3 STARTVERSUCHE.</li> </ol> <p><b>FERNSTART</b></p> <ol style="list-style-type: none"> <li>1. SIEHE BETRIEBSVORSCHRIFT.</li> </ol> <p><b>ABSCHALTEN</b></p> <ol style="list-style-type: none"> <li>1. ALLE AUSSEREN BELASTUNGEN ABSCHALTEN.</li> <li>2. MOTORSTARTSCHALTER AUF POSITION "OFF" DRÜCKEN.</li> <li>3. KRAFTSTOFFTANK FÜLLEN.</li> </ol>									
INSTRUCCIONES PARA LA PUESTA EN MARCHA DE GENERADORES MOVILES	INSTRUCTIONS D'OPERATION DU GENERATEUR MOBILE									
<p><b>ANTES DEL ARRANQUE</b></p> <ol style="list-style-type: none"> <li>1. LEA EL MANUAL DEL OPERARIO.</li> <li>2. NIVELE LA UNIDAD.</li> <li>3. COLOQUE CUNAS DEBAJO DE LAS RUEDAS.</li> <li>4. CONECTE LA UNIDAD A TIERRA.</li> <li>5. CONTROLE TODOS LOS LIQUIDOS.</li> </ol> <p><b>ARRANQUE MANUAL</b></p> <ol style="list-style-type: none"> <li>1. DESCONECTE TODAS LAS CARGAS EXTERNAS.</li> <li>2. AJUSTE LA LLAVE SELECTORA DE VOLTAJE.</li> <li>3. BLOQUEE LA LLAVE SELECTORA DE VOLTAJE.</li> <li>4. GIRE A LA POSICION "ON" EL BOTON DE PARADA DE EMERGENCIA.</li> <li>5. OPRIMA A LA POSICION "ARRANQUE/MARCHA" EL INTERRUPTOR DE ARRANQUE DEL MOTOR.</li> <li>6. EL MOTOR INTENTARA ARRANCAR 3 VECES.</li> </ol> <p><b>ARRANQUE REMOTO</b></p> <ol style="list-style-type: none"> <li>1. VEA EL MANUAL DEL OPERARIO.</li> </ol> <p><b>DETENCION DEL MOTOR</b></p> <ol style="list-style-type: none"> <li>1. DESCONECTE TODAS LAS CARGAS EXTERNAS.</li> <li>2. OPRIMA A LA POSICION "OFF" EL INTERRUPTOR DE ARRANQUE DEL MOTOR.</li> <li>3. LLENE EL TANQUE DE COMBUSTIBLE.</li> </ol>	<p><b>AVANT LE DEMARRAGE</b></p> <ol style="list-style-type: none"> <li>1. LIRE LA NOTICE D'EMPLOI.</li> <li>2. NIVELER LA MACHINE.</li> <li>3. BLOQUER LES ROUES AVEC CALES DE ROUES.</li> <li>4. METTRE A TERRE LA MACHINE.</li> <li>5. VERIFIER LE NIVEAU DE TOUS LES FLUIDES.</li> </ol> <p><b>DEMARRAGE A LA MAIN</b></p> <ol style="list-style-type: none"> <li>1. DECONNECTER TOUS LES REGIMES EXTERNES.</li> <li>2. REGLER LE COMMUTEUR DES TENSIONS D'ALIMENTATION.</li> <li>3. SERRER LE COMMUTEUR DES TENSIONS D'ALIMENTATION.</li> <li>4. TOURNER LE BOUTON D'ARRET D'URGENCE A LA POSITION "ON".</li> <li>5. PRESSER L'INTERRUPTEUR DE DEMARRAGE DU MOTEUR A LA POSITION "DEMARRAGE/MARCHE".</li> <li>6. LE MOTEUR S'ESSAYERA DE DEMARRER 3 FOIS.</li> </ol> <p><b>DEMARRAGE A DISTANCE</b></p> <ol style="list-style-type: none"> <li>1. LIRE LA NOTICE D'EMPLOI.</li> </ol> <p><b>ARRET</b></p> <ol style="list-style-type: none"> <li>1. DECONNECTER TOUS LES REGIMES EXTERNES.</li> <li>2. PRESSER L'INTERRUPTEUR DE DEMARRAGE DU MOTEUR A LA POSITION "OFF".</li> <li>3. REMPLIR LE RESERVOIR A CARBURANT.</li> </ol>									
M	<table border="1" style="width: 100%; border-collapse: collapse;"> <tbody> <tr> <td style="width: 50%;"> <p>OPERATOR'S MANUAL MUST BE STORED ON MACHINE. REPLACEMENT OPERATOR'S MANUAL CAN BE ORDERED THROUGH YOUR LOCAL WACKER DISTRIBUTOR.</p> </td> <td style="width: 50%;"> <p>EL MANUAL DE OPERACION DEBE SER RETENIDO EN LA MAQUINA. CONTACTE A SU DISTRIBUIDOR WACKER MAS CERCANO PARA PEDIR UN EJEMPLAR ADICIONAL.</p> </td> </tr> <tr> <td> <p>DIE BETRIEBSVORSCHRIFT MUSS AN DER MASCHINE AUFBEWAHRT WERDEN. ZUR BESTELLUNG VON ERSATZBÜCHERN WENDEN SIE SICH BITTE AN IHREN ÖRTLICHEN WACKER HÄNDLER.</p> </td> <td> <p>LA NOTICE D'EMPLOI DOIT ETRE MUNIE SUR LA MACHINE. CONTACTER LE DISTRIBUTEUR WACKER LE PLUS PROCHE POUR COMMANDER UN EXEMPLAIRE SUPPLEMENTAIRE.</p> </td> </tr> </tbody> </table>	<p>OPERATOR'S MANUAL MUST BE STORED ON MACHINE. REPLACEMENT OPERATOR'S MANUAL CAN BE ORDERED THROUGH YOUR LOCAL WACKER DISTRIBUTOR.</p>	<p>EL MANUAL DE OPERACION DEBE SER RETENIDO EN LA MAQUINA. CONTACTE A SU DISTRIBUIDOR WACKER MAS CERCANO PARA PEDIR UN EJEMPLAR ADICIONAL.</p>	<p>DIE BETRIEBSVORSCHRIFT MUSS AN DER MASCHINE AUFBEWAHRT WERDEN. ZUR BESTELLUNG VON ERSATZBÜCHERN WENDEN SIE SICH BITTE AN IHREN ÖRTLICHEN WACKER HÄNDLER.</p>	<p>LA NOTICE D'EMPLOI DOIT ETRE MUNIE SUR LA MACHINE. CONTACTER LE DISTRIBUTEUR WACKER LE PLUS PROCHE POUR COMMANDER UN EXEMPLAIRE SUPPLEMENTAIRE.</p>					
<p>OPERATOR'S MANUAL MUST BE STORED ON MACHINE. REPLACEMENT OPERATOR'S MANUAL CAN BE ORDERED THROUGH YOUR LOCAL WACKER DISTRIBUTOR.</p>	<p>EL MANUAL DE OPERACION DEBE SER RETENIDO EN LA MAQUINA. CONTACTE A SU DISTRIBUIDOR WACKER MAS CERCANO PARA PEDIR UN EJEMPLAR ADICIONAL.</p>									
<p>DIE BETRIEBSVORSCHRIFT MUSS AN DER MASCHINE AUFBEWAHRT WERDEN. ZUR BESTELLUNG VON ERSATZBÜCHERN WENDEN SIE SICH BITTE AN IHREN ÖRTLICHEN WACKER HÄNDLER.</p>	<p>LA NOTICE D'EMPLOI DOIT ETRE MUNIE SUR LA MACHINE. CONTACTER LE DISTRIBUTEUR WACKER LE PLUS PROCHE POUR COMMANDER UN EXEMPLAIRE SUPPLEMENTAIRE.</p>									
N		<p><b>DANGER!</b> Electric shock will cause serious injury or death. Danger of asphyxiation!</p>								

Ref.	Label	Meaning
O		<p><b>WARNING!</b> Generator can automatically start which can cause serious injury. Disconnect battery before servicing.</p>
P		<p><b>WARNING!</b> Read and understand the supplied Operator's Manual before operating this machine. Failure to do so increases the risk of injury to yourself or others.</p>
Q		<p><b>WARNING!</b> To reduce the risk of electrical shock, read operator's manual. Improper connection of generator to a building's electrical system can allow electrical current from the generator to backfeed into utility lines. This may result in electrocution of utility workers, fire or explosion. Connections to a building's electrical system must be made by a qualified electrician and comply with all applicable laws and electrical codes.</p>
R		<p>Remote start operation. Read operator's manual for instructions.</p>
S		

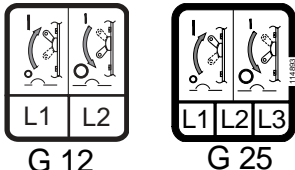
Ref.	Label	Meaning																				
T		<p><b>WARNING!</b> Disconnect battery before servicing. Read the Operator's Manual.</p>																				
U	<table border="1" data-bbox="298 457 1386 613"> <thead> <tr> <th>TRAILER WIRING</th> <th>ANHÄNGER-VERDRÄHTUNG</th> <th>CANALISATION ELECTRICA DE REMOLQUE</th> <th>DISPOSITION DES CABLES POUR REMORQUE</th> </tr> </thead> <tbody> <tr> <td>G - RIGHT BRAKE LIGHT AND DIRECTIONAL Y - LEFT BRAKE LIGHT AND DIRECTIONAL B - TAIL, SIDE AND LICENSE PLATE LIGHTS W - GROUND  L - ELECTRIC BRAKES B - BATTERY CHARGE</td> <td>G - RECHTES BREMSLICHT UND BLINKER Y - LINKES BREMSLICHT UND BLINKER B - SCHLUSS-, SEITEN- UND KENNZEICHENLEUCHE W - ERDUNG  L - ELEKTRISCHE BREMSE B - BATTERIE-LADUNG</td> <td>G - LUZ FRENO Y GIRO DERECHA Y - LUZ FRENO Y GIRO IZQUIERDA B - LUZ TRASERA, LATERAL Y PLACA DE MATRICULA W - TIERRA  L - FRENO ELECTRICOS B - CARGA BATERIA</td> <td>G - FEUX DE STOP ET DE DIRECTION D Y - FEUX DE STOP ET DE DIRECTION G B - FEUX D'ARRIERE, DE POSITION ET DE PLAQUE D'IMMATRICULATION W - MISE A TERRE  L - FREINS ELECTRIQUES B - CHARGE DE LA BATTERIE</td> </tr> </tbody> </table>	TRAILER WIRING	ANHÄNGER-VERDRÄHTUNG	CANALISATION ELECTRICA DE REMOLQUE	DISPOSITION DES CABLES POUR REMORQUE	G - RIGHT BRAKE LIGHT AND DIRECTIONAL Y - LEFT BRAKE LIGHT AND DIRECTIONAL B - TAIL, SIDE AND LICENSE PLATE LIGHTS W - GROUND  L - ELECTRIC BRAKES B - BATTERY CHARGE	G - RECHTES BREMSLICHT UND BLINKER Y - LINKES BREMSLICHT UND BLINKER B - SCHLUSS-, SEITEN- UND KENNZEICHENLEUCHE W - ERDUNG  L - ELEKTRISCHE BREMSE B - BATTERIE-LADUNG	G - LUZ FRENO Y GIRO DERECHA Y - LUZ FRENO Y GIRO IZQUIERDA B - LUZ TRASERA, LATERAL Y PLACA DE MATRICULA W - TIERRA  L - FRENO ELECTRICOS B - CARGA BATERIA	G - FEUX DE STOP ET DE DIRECTION D Y - FEUX DE STOP ET DE DIRECTION G B - FEUX D'ARRIERE, DE POSITION ET DE PLAQUE D'IMMATRICULATION W - MISE A TERRE  L - FREINS ELECTRIQUES B - CHARGE DE LA BATTERIE													
TRAILER WIRING	ANHÄNGER-VERDRÄHTUNG	CANALISATION ELECTRICA DE REMOLQUE	DISPOSITION DES CABLES POUR REMORQUE																			
G - RIGHT BRAKE LIGHT AND DIRECTIONAL Y - LEFT BRAKE LIGHT AND DIRECTIONAL B - TAIL, SIDE AND LICENSE PLATE LIGHTS W - GROUND  L - ELECTRIC BRAKES B - BATTERY CHARGE	G - RECHTES BREMSLICHT UND BLINKER Y - LINKES BREMSLICHT UND BLINKER B - SCHLUSS-, SEITEN- UND KENNZEICHENLEUCHE W - ERDUNG  L - ELEKTRISCHE BREMSE B - BATTERIE-LADUNG	G - LUZ FRENO Y GIRO DERECHA Y - LUZ FRENO Y GIRO IZQUIERDA B - LUZ TRASERA, LATERAL Y PLACA DE MATRICULA W - TIERRA  L - FRENO ELECTRICOS B - CARGA BATERIA	G - FEUX DE STOP ET DE DIRECTION D Y - FEUX DE STOP ET DE DIRECTION G B - FEUX D'ARRIERE, DE POSITION ET DE PLAQUE D'IMMATRICULATION W - MISE A TERRE  L - FREINS ELECTRIQUES B - CHARGE DE LA BATTERIE																			
		<p>A nameplate listing the model number, item number, revision number, and serial number is attached to each unit. Please record the information found on this plate so it will be available should the nameplate become lost or damaged. When ordering parts or requesting service information, you will always be asked to specify the model number, item number, revision number, and serial number of the unit.</p>																				
	<table border="1" data-bbox="282 1188 826 1415"> <thead> <tr> <th colspan="2">MANUFACTURED BY/FABRIQUÉ PAR:</th> <th colspan="2">DATE OF MFG:</th> </tr> </thead> <tbody> <tr> <td>GVWR/PMBV</td> <td></td> <td>COLD INFL. PRESS./PRESS. DE GONF À FROID</td> <td></td> </tr> <tr> <td>GAWR/PNBE</td> <td>TIRE/PNEU - DIMENSION - RIM/JANTE</td> <td>KPA (PSI/LPC)</td> <td>SGL/DUAL</td> </tr> <tr> <td></td> <td></td> <td></td> <td></td> </tr> <tr> <td colspan="4"> <small>THIS VEHICLE CONFORMS TO ALL APPLICABLE STANDARDS PRESCRIBED UNDER THE CANADIAN MOTOR VEHICLE SAFETY REGULATIONS IN EFFECT ON THE DATE OF MANUFACTURE. / CE VÉHICULE EST CONFORME À TOUTES LES NORMES QUI LUI SONT APPLICABLES EN VERTU DU RÈGLEMENT SUR LA SÉCURITÉ DES VÉHICULES AUTOMOBILES DU CANADA EN VIGUEUR À LA DATE DE SA FABRICATION.</small>  <small>THIS VEHICLE CONFORMS TO ALL APPLICABLE U.S. FEDERAL MOTOR VEHICLE SAFETY STANDARDS (FMVSS) IN EFFECT ON THE DATE OF MANUFACTURE SHOWN ABOVE.</small>                      V.I.N./N.I.V.                      TYPE OF VEHICLE/TYPE DE VÉHICULE                 </td> </tr> </tbody> </table>	MANUFACTURED BY/FABRIQUÉ PAR:		DATE OF MFG:		GVWR/PMBV		COLD INFL. PRESS./PRESS. DE GONF À FROID		GAWR/PNBE	TIRE/PNEU - DIMENSION - RIM/JANTE	KPA (PSI/LPC)	SGL/DUAL					<small>THIS VEHICLE CONFORMS TO ALL APPLICABLE STANDARDS PRESCRIBED UNDER THE CANADIAN MOTOR VEHICLE SAFETY REGULATIONS IN EFFECT ON THE DATE OF MANUFACTURE. / CE VÉHICULE EST CONFORME À TOUTES LES NORMES QUI LUI SONT APPLICABLES EN VERTU DU RÈGLEMENT SUR LA SÉCURITÉ DES VÉHICULES AUTOMOBILES DU CANADA EN VIGUEUR À LA DATE DE SA FABRICATION.</small> <small>THIS VEHICLE CONFORMS TO ALL APPLICABLE U.S. FEDERAL MOTOR VEHICLE SAFETY STANDARDS (FMVSS) IN EFFECT ON THE DATE OF MANUFACTURE SHOWN ABOVE.</small> V.I.N./N.I.V. TYPE OF VEHICLE/TYPE DE VÉHICULE				<p>Certification Label (VIN Number) Also attached to each unit is a Certification Label. This label specifies that the trailer conforms with all Federal Motor Vehicle Standards in effect at the time of manufacture. The label includes the Vehicle Identification Number (VIN) for the trailer.</p>
MANUFACTURED BY/FABRIQUÉ PAR:		DATE OF MFG:																				
GVWR/PMBV		COLD INFL. PRESS./PRESS. DE GONF À FROID																				
GAWR/PNBE	TIRE/PNEU - DIMENSION - RIM/JANTE	KPA (PSI/LPC)	SGL/DUAL																			
<small>THIS VEHICLE CONFORMS TO ALL APPLICABLE STANDARDS PRESCRIBED UNDER THE CANADIAN MOTOR VEHICLE SAFETY REGULATIONS IN EFFECT ON THE DATE OF MANUFACTURE. / CE VÉHICULE EST CONFORME À TOUTES LES NORMES QUI LUI SONT APPLICABLES EN VERTU DU RÈGLEMENT SUR LA SÉCURITÉ DES VÉHICULES AUTOMOBILES DU CANADA EN VIGUEUR À LA DATE DE SA FABRICATION.</small> <small>THIS VEHICLE CONFORMS TO ALL APPLICABLE U.S. FEDERAL MOTOR VEHICLE SAFETY STANDARDS (FMVSS) IN EFFECT ON THE DATE OF MANUFACTURE SHOWN ABOVE.</small> V.I.N./N.I.V. TYPE OF VEHICLE/TYPE DE VÉHICULE																						
		<p>Operating the main circuit breaker supplies or interrupts power to the customer connection lugs.</p>																				

## 1.8 Calling for Service

When ordering parts or requesting service information, you will always be asked to specify the model, item number, revision number, and serial number of the unit. You will find this information on the nameplate mounted on or near to the generator's control panel.

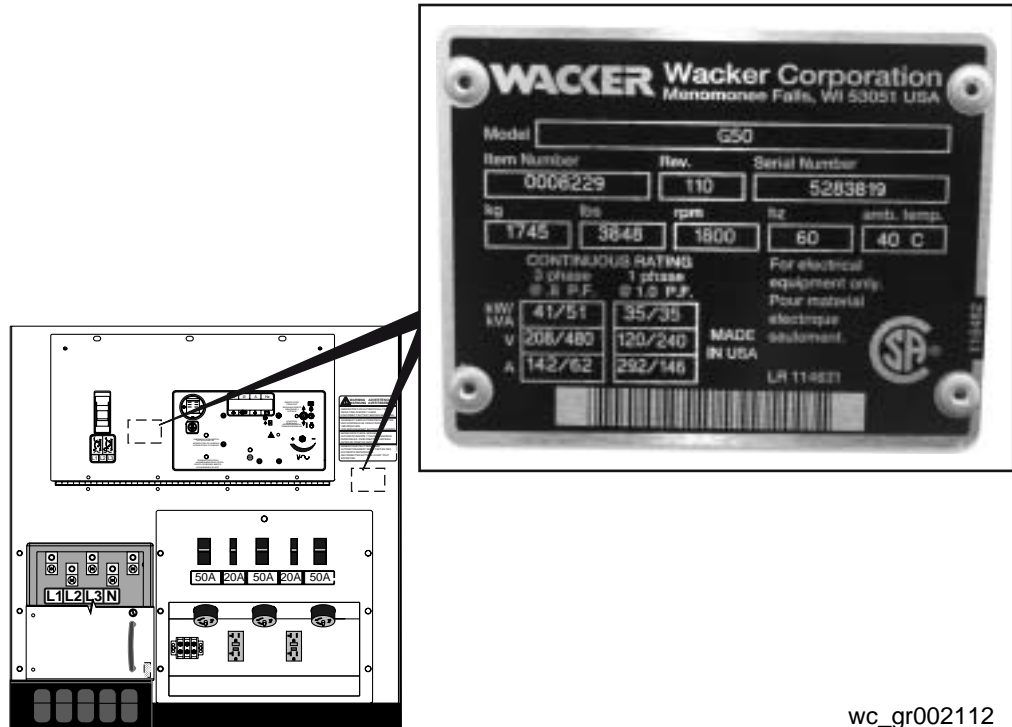

wc\_gr002112

**Notes**

2. Technical Data

2.1 Engine Data—G 25

	<b>G 25</b> 0009258, 0009462 0009476	
<b>Engine</b>		
Engine make / type	Isuzu	
Model	4LE1PV	
Number of cylinders	4	
Displacement	cm <sup>3</sup> (in <sup>3</sup> )	2180 (133)
Engine speed	rpm	1800
Power @ 1800 rpm - continuous/standby	kW/Hp	25.7 (34.5)
Coolant capacity	l (qts.)	11.3 (11.9)
Oil capacity	l (qts.)	8.0 (8.5)
Battery	Volts/CCa	12/650
Fuel type	Diesel	
Fuel tank capacity	l (gal.)	216 (57)
Fuel consumption, continuous load	l/hr (gal./hr)	7.4 (1.95)
Running time, continuous load	Hours	29

2.2 Generator Data—G 25

	<b>G 25</b> 0009258, 0009462 0009476	
<b>Generator</b>		
Make/Type	Marathon / Brushless	
Model	282PSL1540	
Generator speed	rpm	1800
Voltage selector switch	3 position	
AC voltages available	120/240 zig-zag 120/208 low-wye 277/480 Hi-wye	
Frequency	60 Hz	
Power factor	1ø 3ø	1.0 0.8
Voltage regulation	±1.00%	
Insulation class	H	
Sound level at 7 m (23 ft.)	dB(A)	69
AC receptacles	2 duplex, 2 twist-lock	
1ø 120 GFI duplex	Amps	2-20
1ø 120/240 V twist lock	Amps	1-30 1-50
Standby Output	kW/kVA	20/25
Continuous Output	kW/kVA	18/23

2.3 Trailer and Skid Data—G 25

		<b>G 25</b> 0009258, 0009462 0009476
<b>Trailer and Skid</b>		
Dry weight of skid	kg (lbs.)	816 (1800)
Operating weight of skid	kg (lbs.)	984 (2170)
Trailer weight	kg (lbs.)	181 (400)
GVWR	kg (lbs.)	1338 (2995)
Surge brakes	Fluid type	DOT3
Tires	size	ST205/75D-15C

2.4 Dimensions—G 25

in. (mm)

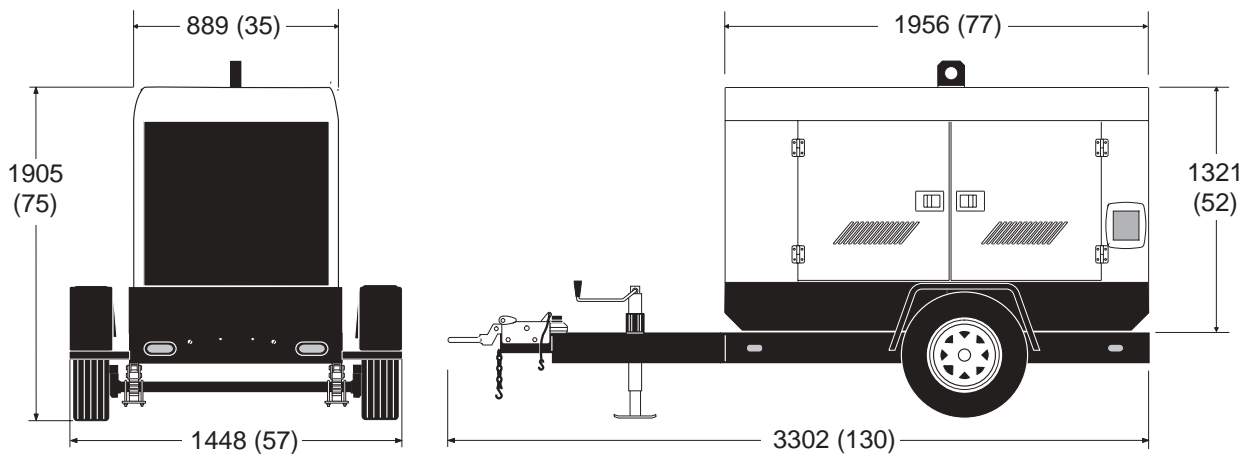

wc\_gr001647

**2.5 Engine Data—G 50, G 70, G 85**

	<b>G 50</b> 0009259 Rev. 114 and lower, 0009463, 0009477	<b>G 70</b> 0009260 Rev. 113 and lower, 0009464, 0009478	<b>G 85</b> 0009310
<b>Engine</b>			
Engine make / type	John Deere / 4.5L		
Model	4045DF150	4045TF150	4045TF250
Number of cylinders	4		
Displacement l (in <sup>3</sup> )	4.5 (274.6)		
Engine speed rpm	1800		
Power @ 1800 rpm - continuous/standby kW/Hp	52.9/71	90/99	102/113
Coolant capacity l (qts.)	22.7 (24)		
Oil capacity l (qts.)	13.5 (14)		
Battery Volts/CCa	12/720		
Fuel type	Diesel		
Fuel tank capacity l (gal.)	329.3 (87)		
Fuel consumption, con- tinuous load l/hr (gal./ hr)	12.5 (3.3)	16.7 (4.4)	18.6 (4.9)
Running time, continu- ous load Hours	26.3	19.8	17.7

2.6 Generator Data—G 50, G 70, G 85

	<b>G 50</b> 0009259 Rev. 114 and lower, 0009463, 0009477	<b>G 70</b> 0009260 Rev. 113 and lower, 0009464, 0009478	<b>G 85</b> 0009310
<b>Generator</b>			
Make/Type	Marathon/ Brushless		
Model	361PSL1648	361PSL1647	361PSL1649
Generator speed rpm	1800		
Voltage selector switch	3 position		
AC voltages available	120/240 zig-zag 120/208 low-wye 277/480 Hi-wye		
Frequency	60 Hz		
Power factor	1∅ 3∅		
Power factor	1.0 0.8		
Voltage regulation	±1.00%		
Insulation class	H		
Sound level at 7 m (23 ft.) dB(A)	71	69	70
AC receptacles	2 duplex, 3 twist-lock		
1∅ 120 GFI duplex Amps	2-20		
1∅ 120/240 V twist lock Amps	1-30A 2-50A		
Standby Output kW/kVA	43/54	62/78	72/90
Prime Output kW/kVA	40/50	57/71	66/83
Main breaker Amps	175	225	250

**2.7 Trailer Technical Data—G 50, G 70, G 85**

		<b>G 50</b> 0009259 Rev. 114 and lower, 0009463, 0009477	<b>G 70</b> 0009260 Rev. 113 and lower, 0009464, 0009478	<b>G 85</b> 0009310
<b>Trailer and Skid</b>				
Dry weight of skid	kg (lbs.)	1550 (3418)	1583 (3490)	1622 (3576)
Operating weight of skid	kg (lbs.)	1745 (3848)	1778 (3920)	1817 (4006)
Trailer weight	kg (lbs.)			
	Single axle	442 (975)		
	Tandem axle	499 (1100)		
GVWR	kg (lbs.)			
	Single axle	2304 (5080)		
	Tandem axle	2722 (6000)		
Surge brakes	Fluid type	DOT3		
Tires	size	ST225/75D-15D		

2.8 Dimensions—G 50, G 70, G 85

in. (mm)

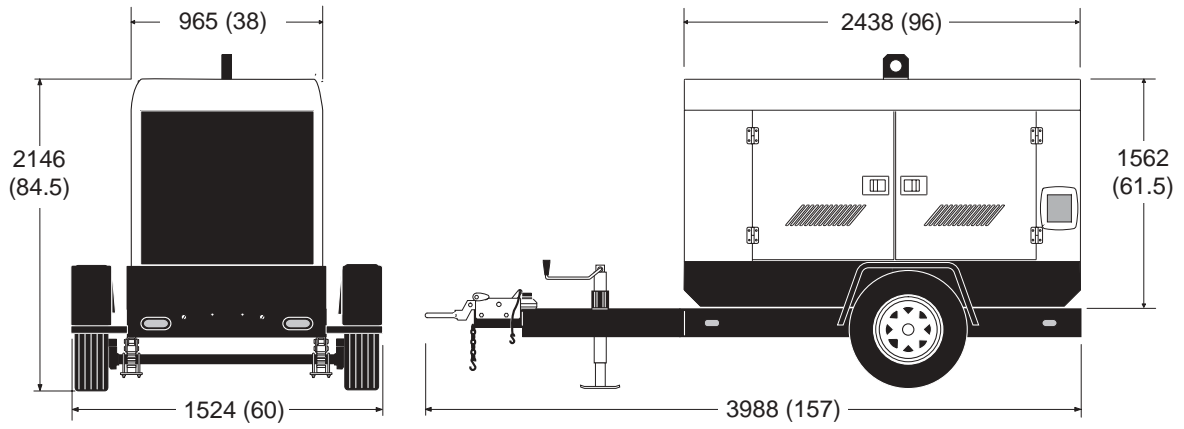

wc\_gr001648

**2.9 Engine Data—G 125, G 160**

		<b>G 125</b> 0009261 0620067 0620068	<b>G 160</b> 0009306 0620069 0620070
<b>Engine</b>			
Engine make / type	John Deere / 6.8L		
Model	6068TF275	6068HF275	
Number of cylinders	6		
Displacement	cm <sup>3</sup> (in <sup>3</sup> )	6800 (414)	
Engine speed	rpm	1800	
Power @ 1800 rpm - continuous/standby	kW/Hp	123/165	164/220
Coolant capacity	l (qts.)	37.8 (40)	24.2 (25.6)
Oil capacity	l (qts.)	18.9 (20.0)	32.0 (34.0)
Battery	Volts/CCa	12/1000	
Fuel type	Diesel		
Fuel tank capacity	l (gal.)	927 (245)	
Fuel consumption, continuous load	l/hr (gal./hr)	29.0 (7.7)	37.1 (9.8)
Running time, continuous load	Hours	31.9	25.0

2.10 Generator Data—G 125, G 160

		<b>G 125</b> 0009261 0620067 0620068	<b>G 160</b> 0009306 0620069 0620070
<b>Generator</b>			
Make/Type	Marathon/ Brushless		
Model	362 PSL 1650	363 PSL 1661	
Generator speed	rpm	1800	
Voltage selector switch	3 position		
AC voltages available	120/240 zig-zag 120/208 low-wye 277/480 Hi-wye		
Frequency	60 Hz		
Power factor	1ø 3ø	1.0 0.8	
Voltage regulation	±1.00%		
Insulation class	H		
Sound level at 7 m (23 ft.)	dB(A)	68	69
AC receptacles	2 duplex, 3 twist-lock		
1ø 120 GFI duplex	Amps	2-20	
1ø 120/240 V twist lock	Amps	1-30A 2-50A	
Standby Output	kW/kVA	109/136	141/176
Prime Output	kW/kVA	98/122	128/160
Main breaker	Amps	400	500

2.11 Trailer Technical Data—G 125, G 160

		<b>G 125</b>	<b>G 160</b>
		0009261	0009306
		0620067	0620069
		0620068	0620070
<b>Trailer and Skid</b>			
Dry weight of skid	kg (lbs.)	2331 (5140)	2400 (5290)
Operating weight of skid	kg (lbs.)	3139 (6920)	3207 (7070)
Trailer weight	kg (lbs.)	649 (1430)	
GVWR	kg (lbs.)	4082 (9000)	
Surge brakes	Fluid type	DOT3	
Tires	size	7.50x16	

2.12 Dimensions—G 125, G 160

mm (inches)

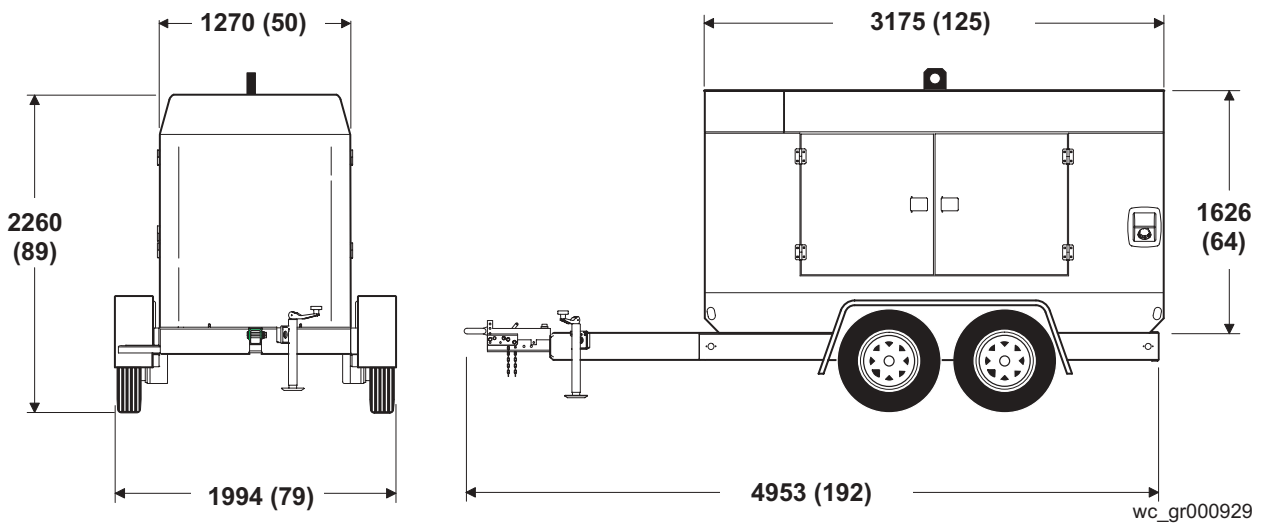

### 2.13 Isuzu Engine Performance Data

Performance data on Isuzu engines are measured at the following standard conditions:

- 29.31 inches of mercury dry air pressure
- 600 feet altitude
- 0 % relative humidity
- 77°F air intake temperature
- 104°F fuel inlet temperature

Refer to the table to estimate the engine power decrease in percent, as environmental factors vary from the standard conditions.

MODEL	FUEL TEMP RISE of 1.8°F	AIR TEMP RISE of 10°F	ALTITUDE RISE of 305 m (1000 ft)	RELATIVE HUMIDITY RISE of 10%
G 12 G 25	0.17	1.50	3.00	0.10

**2.14 John Deere Engine Performance**

Performance data on John Deere engines are measured at the following standard conditions:

- 29.31 inches of mercury dry air pressure
- 600 feet altitude
- 0 % relative humidity
- 77°F air intake temperature
- 104°F fuel inlet temperature

Refer to the table to estimate the engine power decrease in percent, as environmental factors vary from the standard conditions.

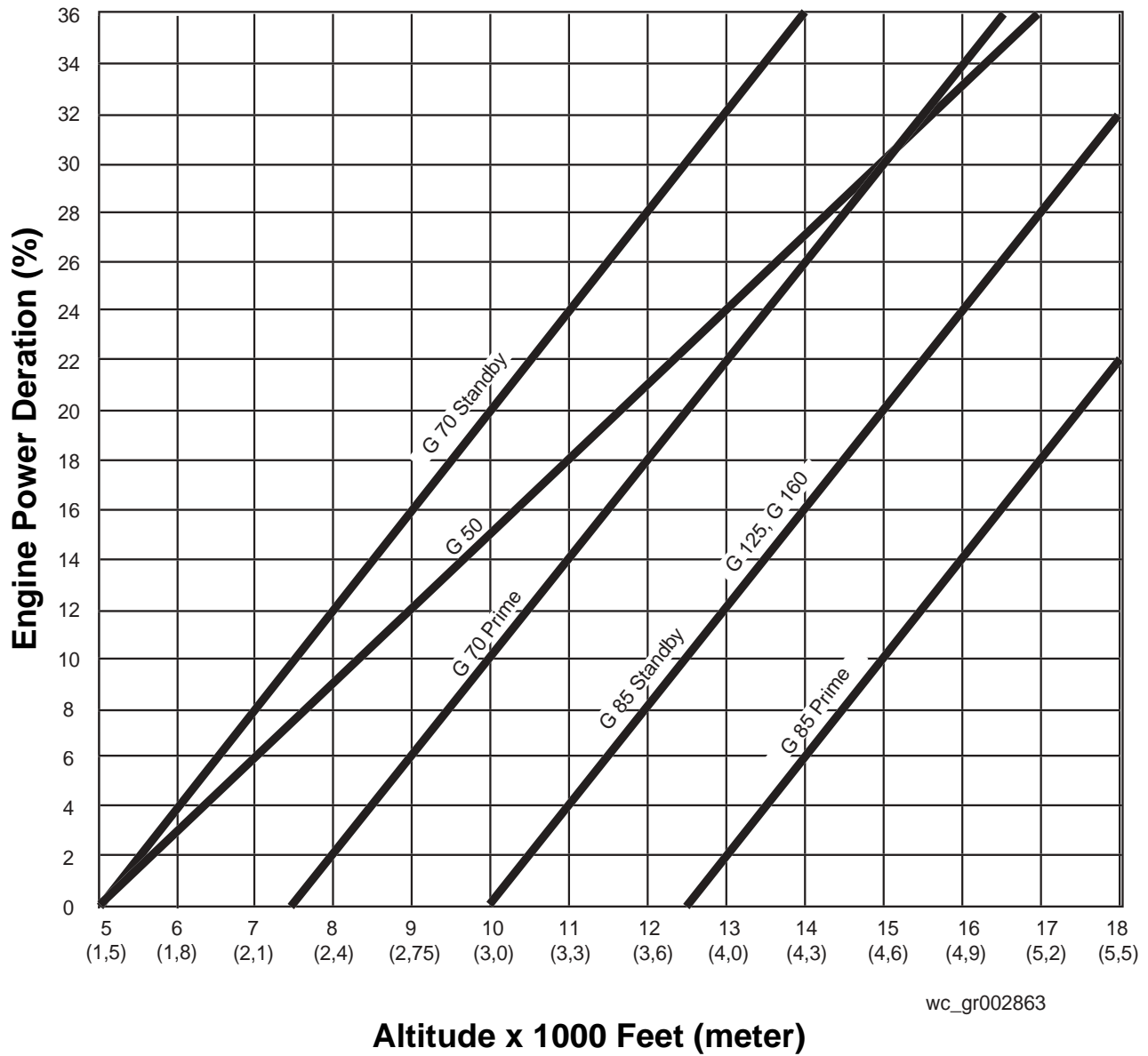

MODEL	FUEL TEMP RISE of 1.8°F	AIR TEMP RISE of 10°F	ALTITUDE RISE of 305 m (1000 ft)	RELATIVE HUMIDITY RISE of 10%
G 50	0.17	1.50	see chart	0.10
G 70 G 85 G 125 G 160	0.19	0.50	see chart	0.07

**3. Maintenance**

**3.1 Periodic Maintenance Schedule**

The Periodic Maintenance Schedule below lists basic maintenance intervals for the engine and generator. For detailed maintenance procedures on the engine, refer to the engine Operator's Manual.

	Daily	50 Hrs or 2 weeks	250 Hrs	600 Hrs or 12 Mo	1200 Hrs or 24 Mo	2000 Hrs	Other
Check engine oil and coolant level	•						
Check engine air filter gauge & air cleaner dust cap *	•						
Visual walkaround inspection	•						
Check tire inflation, tread wear and lug nuts before towing	•						
Check fuel filter		•					
Service the battery			•				
Change engine oil and replace oil filter**			•				
Clean unit inside and out			•				
Check air intake hoses, connections, and system				•			
Replace fuel filter element				•			
Check automatic belt tensioner and belt wear				•			
Check cooling system				•			
Perform coolant solution analysis & add SCA's				•			
Grease axle				•			
Pressure test cooling system					•		
Flush cooling system***					•		
Check and adjust engine valve clearance						•	
Check brake fluid level in trailer at least monthly							•
Replace crankcase ventilation filter every 750 hours							•

\*Replace the air filter cartridge when yellow indicator of the engine air filter gauge reaches the red line.

\*\*Change the oil after the first 100 hours, then every 250 hours.

\*\*\*If John Deere antifreeze is used, the flushing interval may be extended. See engine Operator's Manual.

### 3.2 Resetting the Periodic Maintenance Timer

After maintenance has been performed on the generator, it is necessary to reset the periodic maintenance timer.

- If the periodic maintenance timer is at zero, press the ENG. HRS switch UP and hold for 10 seconds until the “TIME TO SERVICE” resets to 250 hours.
- If the service time is greater than zero (maintenance was performed prior to the timer running out) press and hold the ENG. HRS switch UP and hold for 30 seconds. This will reset the “TIME TO SERVICE” to 250 hours.

### 3.3 Air Cleaner

See Graphic: *wc\_gr000511*

Replace the air filter cartridge when yellow indicator of the engine air filter gauge reaches the red line.

The air cleaner assembly contains a one-piece single element air filter cartridge **(c)**.

To replace the air filter cartridge:

- Remove the end cover **(d)**, then discard the entire air filter cartridge.
- Insert a new air filter cartridge, then
- Re-install the end cover, making sure that the dust cap **(e)** is clean and is pointing downward.

Periodically, make sure the inlet pipe **(f)** is free from obstructions.

Check all connections and make sure they are snug. An air leak at the neck clamp, gauge connection, or intake pipe can quickly lead to expensive engine repairs.

- Make sure that the intake piping **(a)** is fully engaged over the neck of the filter to ensure a good seal.
- If the filter housing, gauge connection **(b)**, neck, or inlet pipe are crushed or damaged, replace them immediately.

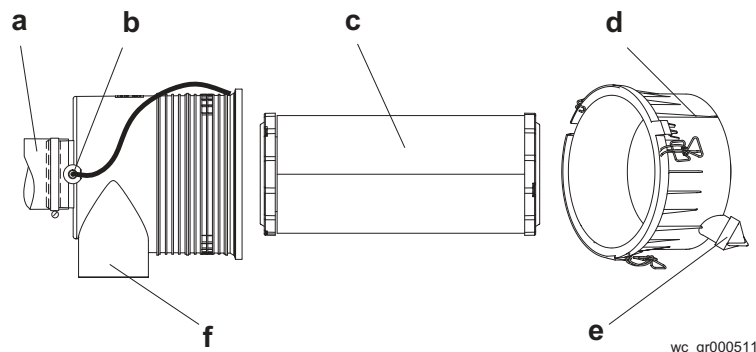

### 3.4 Engine Lubrication

John Deere Engines:

Check engine oil daily before starting engine.

**DO NOT** operate engine if oil level is below ADD mark on dipstick. Always keep oil level within the crosshatch pattern or “full” mark on dipstick.

Change oil after first 100 hours of operation and every 250 hours thereafter. Refer to the engine Operator’s Manual for lubrication specifications.

#### Break-in Service

3.4.1 This engine is factory-filled with John Deere Engine Break-in Oil. Operate the engine at heavy loads with minimal idling during the break-in period. **DO NOT** exceed 100 hours of operation with break-in oil.

3.4.2 If the engine has significant operating time at light load, or makeup oil is required in the first 100 hour period, a longer break-in period may be required. In these situations, an additional 100 hour break-in period is recommended using a new change of John Deere Engine Break-In Oil and a new John Deere oil filter.

**CAUTION: DO NOT** add makeup oil until the oil level is **BELOW** the ADD mark on dipstick. John Deere Engine Break-In Oil (TY22041) should be used to make up any oil consumed during the break-in period.

3.4.3 During the first 20 hours, avoid prolonged periods of no load or sustained maximum load operation. If engine is to run for longer than 5 minutes without a load, shut unit down.

3.4.4 After the first 100 hours, change engine oil and replace engine oil filter. Fill crankcase with seasonal viscosity grade oil.

Isuzu Engines:

3.4.5 Check engine oil daily before starting engine.

3.4.6 **DO NOT** operate engine if oil level is below ADD mark on dipstick. Always keep oil level within the crosshatch pattern or “full” mark on dipstick.

3.4.7 Change oil after first 50 hours of operation and every 250 hours thereafter. Refer to the engine manufacturer’s Operator’s Manual for lubrication specifications.

### 3.5 Engine Coolant

Check the coolant level of the radiator with the engine cold. After initial filling of radiator to 3/4" below bottom of filler neck, maintain proper level in overflow bottle daily.



**WARNING**

**NEVER** remove radiator cap or drain plug while engine is hot! Pressurized coolant can cause serious burns.

Shut off engine. Only remove radiator cap when it is cool enough to touch with bare hands. Slowly loosen cap to relieve pressure first, before removing it completely.

Solutions of antifreeze and supplemental coolant additives **MUST** be used year-round. Automotive-type coolants do not contain the correct coolant additives to protect heavy-duty diesel engines. They often contain a high concentration of silicates which can damage the engine and cooling system. Refer to engine Operator's Manual for coolant recommendations.

### 3.6 Trailer Maintenance

**Tires** - Keep tires inflated to the proper pressure as shown on the tire sidewall, and check tread periodically for wear. Replace tires as required.

**Wheels** - Check that lug nuts holding wheels are tight. Replace any missing nuts immediately.

**Axle Hubs** - Grease axle hubs through grease fittings using a good wheel bearing grease.

**Brakes** - Check operation of brakes before each trip.

Check level of brake fluid in actuator at front of trailer at regular intervals. Fill to approximately 1" below top of reservoir using DOT-3 heavy-duty brake fluid. Tighten filler plug securely.

**Note:** *If fluid level has fallen too low, bleed brake lines to remove any air trapped in lines.*

**3.7 Trailer Wiring—G 25, G 50, G 70, G 85**

Ref.	Description
1	Front right side amber light
2	Front left side amber light
3	Trailer plug
4	Battery
5	Brake solenoid
6	Right rear taillight
7	License plate holder lights
8	Left rear taillight
9	Rear right side red light
10	Rear left side red light

Ref.	Wire Colors	Rear Lights	Side Lights	Harness
<b>B</b>	BLACK	Ground	Ground	Battery charge
<b>Br</b>	BROWN	Taillight		Tail, side and license plate
<b>L</b>	BLUE			
<b>R</b>	RED	Brake light	Power	Electric brakes
<b>Y</b>	YELLOW			Left brake light and directional
<b>G</b>	GREEN			Right brake light and directional
<b>W</b>	WHITE			Ground

## Standard and Hydraulic Brakes

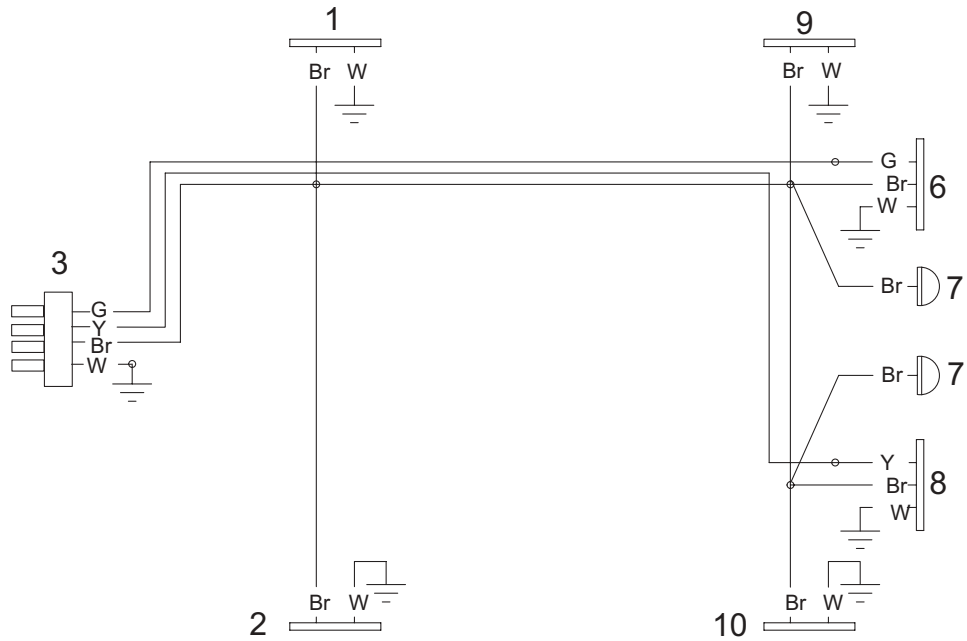

wc\_gr000522

## Electric Brakes

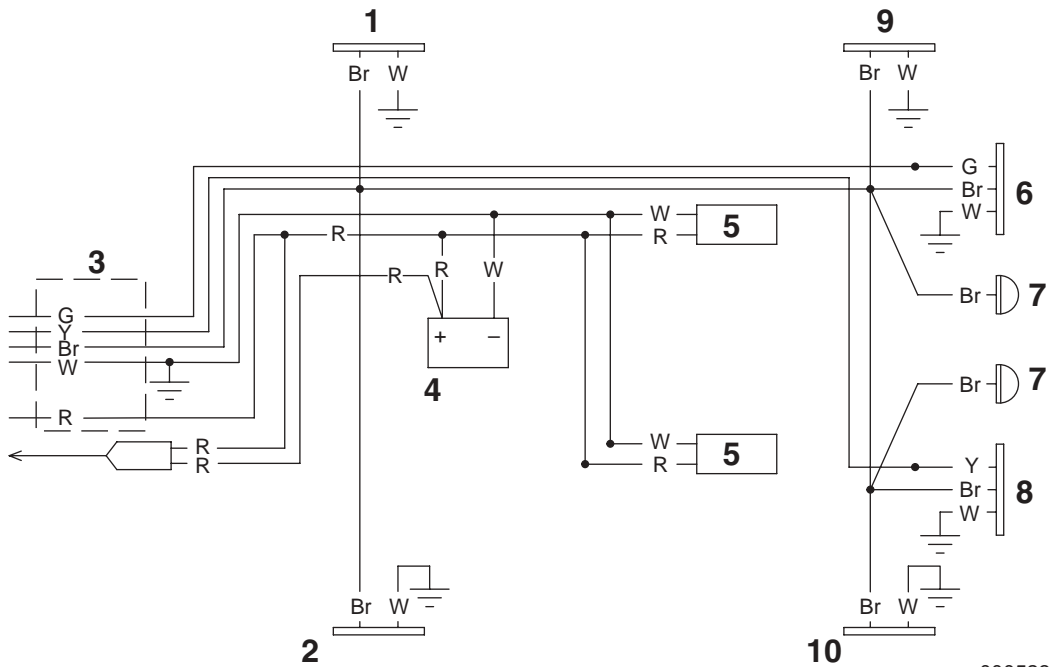

wc\_gr000523

**3.8 Trailer Wiring—G 125, G 160**

Ref.	Description
1	Front right side amber light
2	Front left side amber light
3	Trailer plug
4	Battery
5	Brake solenoid
6	Right rear taillight
7	License plate holder lights
8	Left rear taillight
9	Rear right side red light
10	Rear left side red light

Ref.	Wire Colors	Rear Lights	Side Lights	Harness
<b>B</b>	BLACK	Ground	Ground	Battery charge
<b>Br</b>	BROWN	Taillight		Tail, side and license plate
<b>L</b>	BLUE			
<b>R</b>	RED	Brake light	Power	Electric brakes
<b>Y</b>	YELLOW			Left brake light and directional
<b>G</b>	GREEN			Right brake light and directional
<b>W</b>	WHITE			Ground

## Standard and Hydraulic Brakes

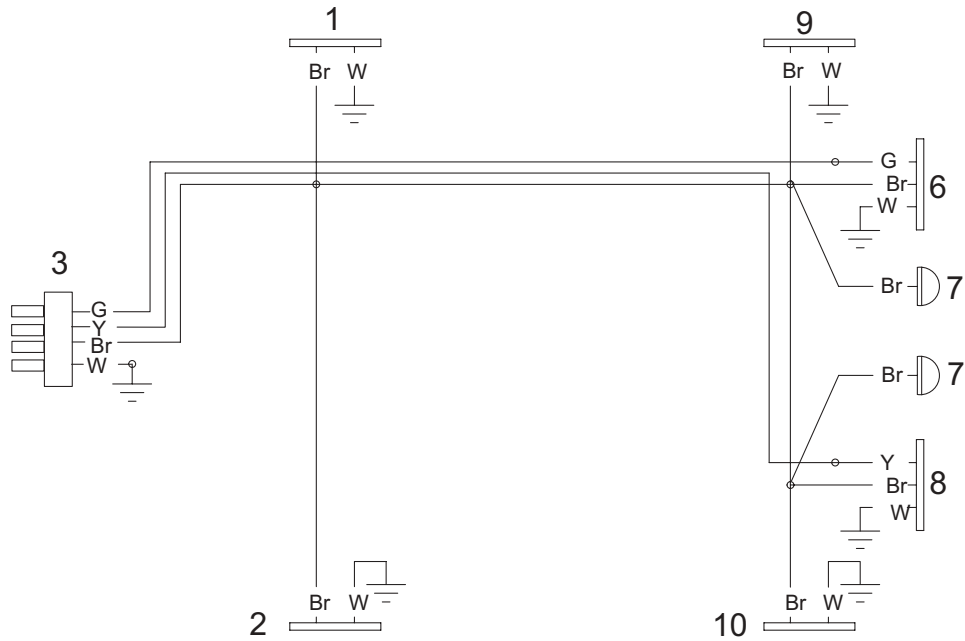

wc\_gr000522

## Electric Brakes

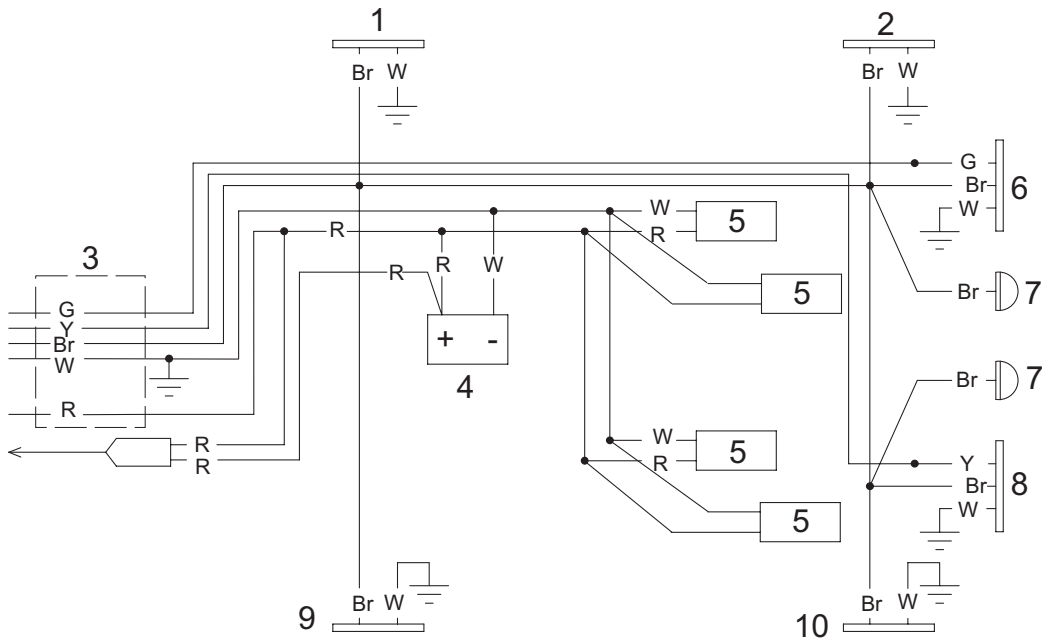

wc\_gr001226

**Notes**

## 4. Theory of Operation

### 4.1 Introduction

*See Graphic: wc\_gr002915*

A generator set is a transducer, which means it converts energy from one form (heat) into another (electrical). The two main components of a generator set are the prime mover (engine) and the generator assembly. The engine converts heat into rotating mechanical energy which is then converted by the generator assembly into electrical energy. The generator does so through the principle of electromagnetic induction. This principle states that when a coil of wire (also referred to as an armature), is passed through a magnetic field, a voltage is induced in the coil of wire. The amount of voltage depends on three factors: 1) the speed of the coil cutting through the magnetic field (it does not matter which is moving—either the magnetic field or the coil); 2) the strength of the magnetic field; and 3) the amount of turns of wire in the coil. The principle also works in reverse; that is, if a voltage and current is present in a coil of wire, a magnetic field is produced. It is important to understand this basic theory to understand how the generator functions.

The typical brushless generator assembly consists of a stator (stationary), a rotor (rotating), a voltage regulator (voltage control device), and a rectifier assembly (current control device). The rotor can function as either the magnetic field or the coil. Likewise, the stator can function as either the magnetic field or the coil, depending on application. In Wacker generators, there are two such sets of stators and rotors—the exciter and the main. The function of the exciter is to supply a current for voltage to the main rotor windings. The current is first rectified to direct current (DC) by the diodes in the rectifier assembly. When supplied with the DC and voltage, the main rotor windings become an electromagnet whose field sweeps through the main stator windings as the engine rotates. The voltage and resulting current induced in the main stator windings is used to supply power to the receptacles and lugs.

4.2 Basic Generator Schematic

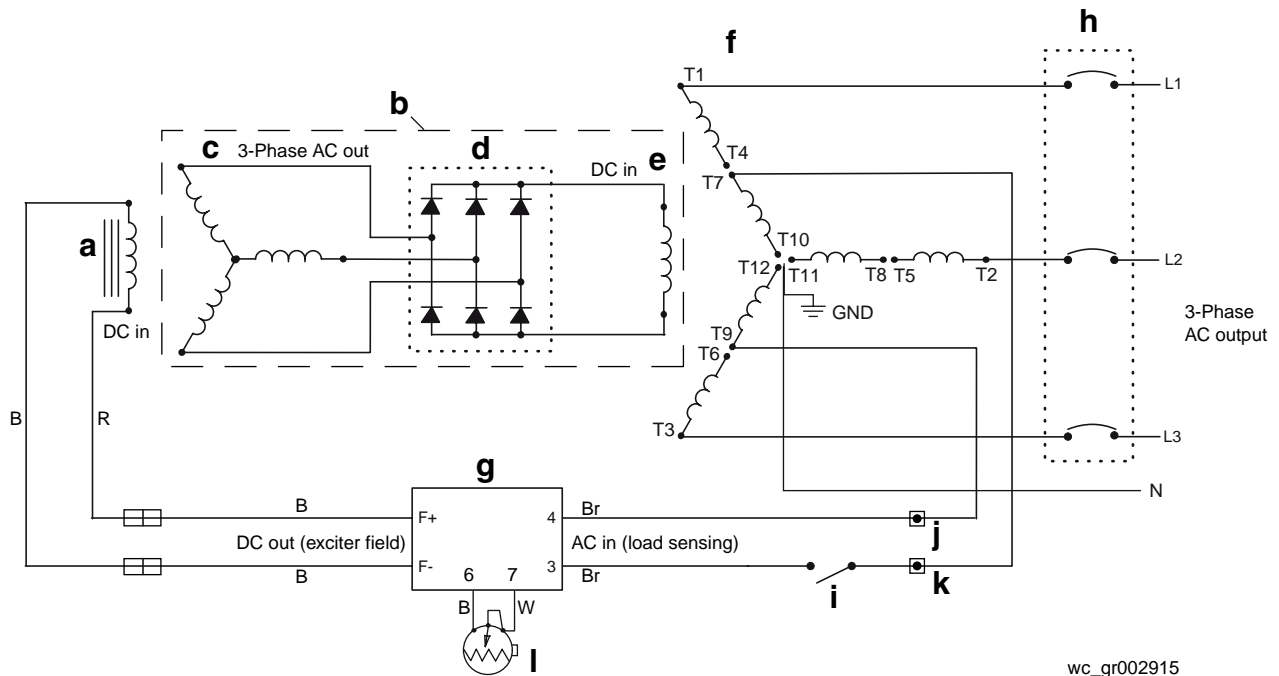

wc\_gr002915

Ref.	Component	Ref.	Component
a	Exciter stator	g	Automatic voltage regulator (AVR)
b	Rotor assembly	h	Main circuit breaker
c	Exciter rotor	i	Switch, lug door
d	Rotating rectifier	j	Lug, T9
e	Main field (rotor)	k	Lug, T7
f	Main windings (stator)	l	Rheostat, voltage adjusting

4.3 Generator Components

Cross section

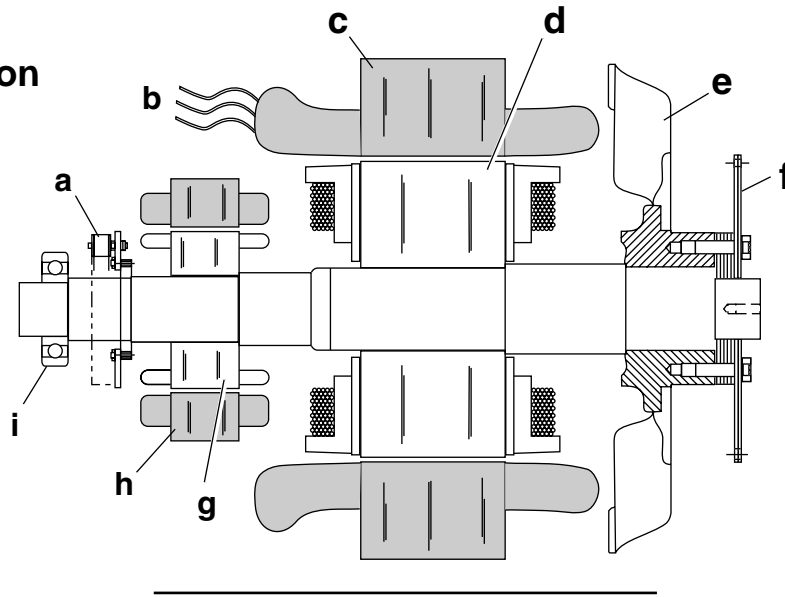

Sample rotor assembly

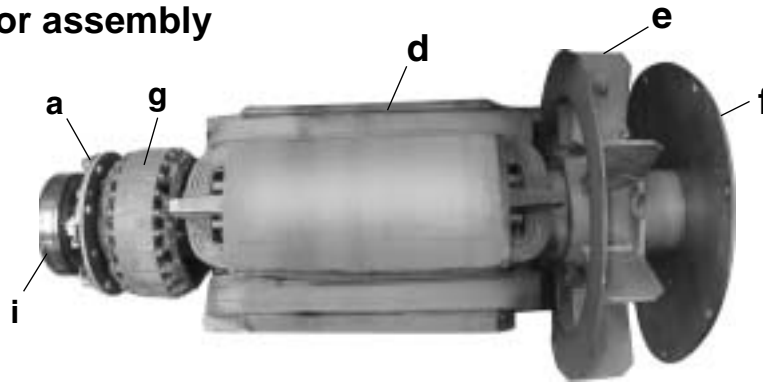

wc\_gr002916

Ref.	Component	Ref.	Component
a	Rotating rectifier	f	Drive disc
b	Main stator AC output	g	Exciter rotor (windings) (3 phase)
c	Main stator (windings)	h	Exciter stator (field)
d	Main rotor (field)	i	Bearing
e	Cooling fan		

4.4 Wiring Diagrams

G 25

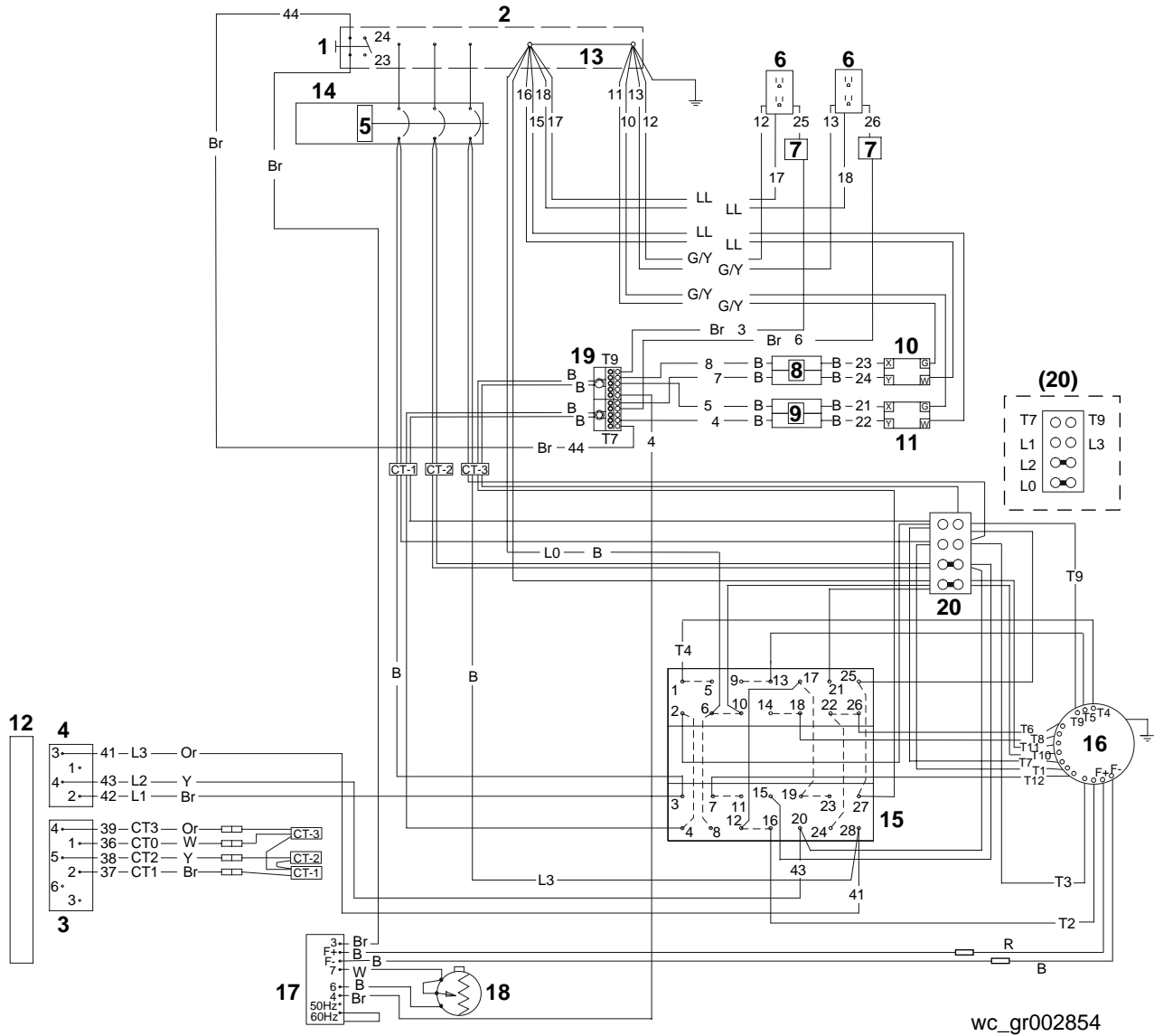

Wire Colors							
B	Black	R	Red	Y	Yellow	Or	Orange
G	Green	T	Tan	Br	Brown	Pr	Purple
L	Blue	V	Violet	Cl	Clear	Sh	Shield
P	Pink	W	White	Gr	Gray	LL	Light blue

See Graphic: wc\_gr002854

Ref.	Description	Ref.	Description
1	Lug door switch	11	120/240V 30A receptacle
2	Mechanical lugs	12	Engine Control Module (ECM)
3	Plug 3 - current transformer inputs, ECM	13	Buss bar
4	Plug 4 - line voltage inputs, ECM	14	Main breaker
5	Shunt trip, main breaker	15	Voltage Selector Switch (VSS) (1 or 3 phase)
6	120V 20A GFI receptacle	16	Generator
7	20A breaker	17	Automatic Voltage Regulator (AVR) with 4A fuse
8	50A breaker	18	Voltage adjustment rheostat (on panel)
9	30A breaker	19	Terminal lugs
10	120/240V 50A receptacle	20	Terminal block



Wire Colors							
B	Black	R	Red	Y	Yellow	Or	Orange
G	Green	T	Tan	Br	Brown	Pr	Purple
L	Blue	V	Violet	Cl	Clear	Sh	Shield
P	Pink	W	White	Gr	Gray	LL	Light blue

See Graphic: wc\_gr002917

Ref.	Description	Ref.	Description
1	Lug door switch	11	120/240V 30A receptacle
2	Mechanical lugs	12	Engine Control Module (ECM)
3	Plug 3 - current transformer inputs, ECM	13	Buss bar
4	Plug 4 - line voltage inputs, ECM	14	Main breaker
5	Shunt trip, main breaker	15	Voltage Selector Switch (VSS) (1 or 3 phase)
6	120V 20A GFI receptacle	16	Generator
7	20A breaker	17	Automatic Voltage Regulator (AVR) with 4A fuse
8	50A breaker	18	Voltage adjustment rheostat (on panel)
9	30A breaker	19	Terminal lugs
10	120/240V 50A receptacle	20	Terminal block

4.5 Generator Systems

The generator can be divided into four basic systems:

- 1) Power Generation and Output. This system includes the generator, voltage selector switch, receptacles, customer connect lugs and circuit breakers.
- 2) Voltage Regulation. Consisting primarily of the voltage regulator and exciter field winding, this system controls the voltage output of the generator.
- 3) Engine Start. This system includes the relays and solenoids needed to start the engine. This system is activated by the ECM.
- 4) ECM Monitoring System. This system monitors engine and generator functions during operation. It includes the current transformers and engine sensors. It responds to possible malfunctions by closing the engine fuel valve to shut down the engine.

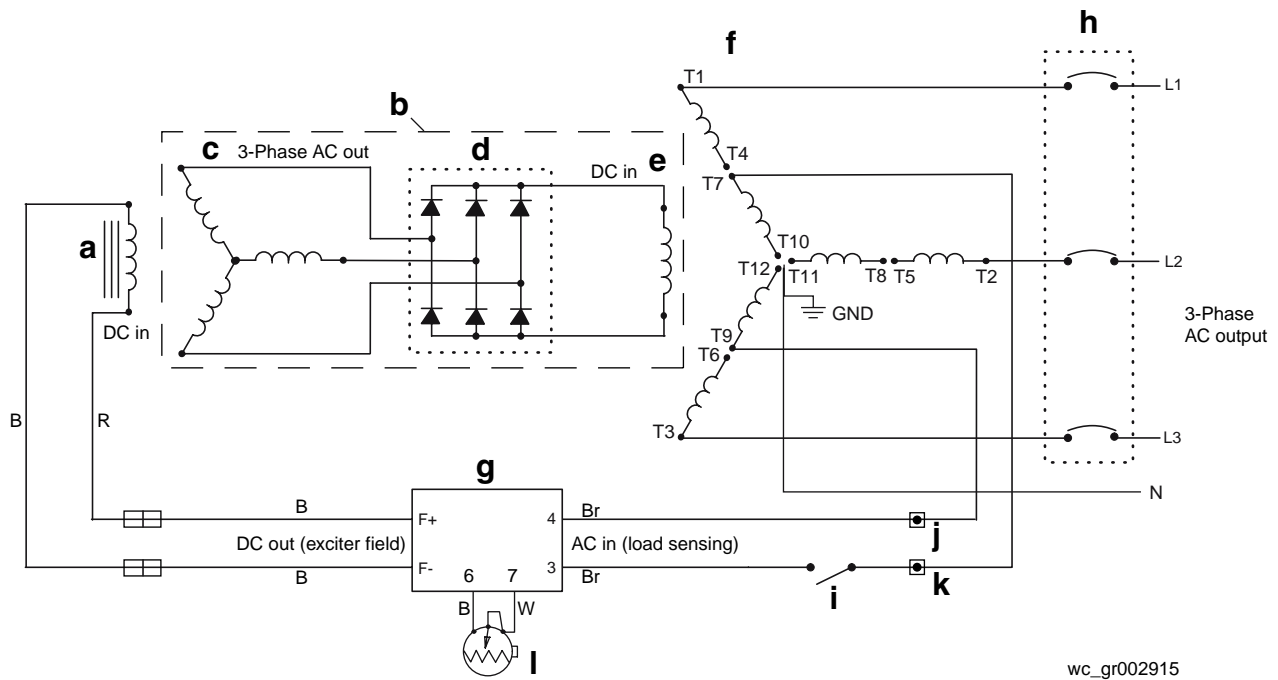

## 4.6 Power Generation & Output

See Graphic: *wc\_gr002915*

### General Operation

The figure shows the basic configuration of the generator. This configuration remains the same for all generator sizes and models.

The exciter stator (**a**) is designed to be the primary source of the generator's residual magnetism. When the machine's engine is first started, this residual magnetism induces a small AC voltage and current in the exciter rotor (**c**) as it rotates inside the exciter stator. The three-phase AC voltage and current generated in the exciter rotor is rectified to DC by a three-phase full wave rotating rectifier (**d**) mounted on the end of the rotor assembly. This rectified DC voltage and current flow through the main rotor windings (**e**) and create the initial magnetic field buildup (excitation) on the rotor.

As the main rotor field turns, a low residual voltage is induced in the generator's main stator windings (**f**). This residual voltage and current activate the automatic voltage regulator (**g**) via the sensing/power wires (Br on 3 and 4) which are connected to a specific point(s) of the main stator windings. The voltage regulator sends DC voltage and current to the exciter stator (**a**) which increases the induced voltage and current to the exciter rotor windings (**c**) thus allowing the generator to build up to its rated voltage.

The voltage regulator senses the load on the generator via leads (Br on 3 and 4) on the main stator. During operation, it continues to control the input voltage to the exciter field through wires F- and F+. As the load on the generator increases, the voltage regulator increases DC voltage to the exciter field and thus maintains the desired output voltage on the main stator windings.

### Main Stator Connections

The main stator (**f**) consists of 6 windings with 12 output leads, labeled T1 through T12. T7 (**k**) and T9 (**j**) are connected to a terminal block inside the control box. These two wires provide power to the convenience receptacles as well as power and sensing to the voltage regulator. Refer to Generator and Receptacle Wiring diagrams.

See Graphic: *wc\_gr002767*

### **Voltage Selector Switch (VSS)**

The VSS changes connections between the six main windings to form three different configurations:

- High Wye (277/480V 3Ø)
- Low Wye (120/208V 3Ø)
- Zig-Zag (120/240V 1Ø)

The main stator windings connect to one side of the VSS at the terminals. Output leads from the other side of the VSS are directed through the current transformers and then to both the main circuit breaker and the receptacles. With the breaker(s) closed, the appropriate voltage is supplied to the main connection lugs or receptacles.

During normal operation, each of the six windings on the main stator will develop between 120–139VAC. The exact voltage depends on the setting of the voltage selector switch and the voltage adjustment rheostat. The ends of each winding are identified as: T1-T4, T2-T5, T3-T6, T7-T10, T8-T11, T9-T12.

A voltage reading taken across any winding should measure between 120–139VAC.

The voltage selector switch connects the six main stator windings together into the three configurations shown in the chart. (The same chart is also found on the lug door.) Inter-winding connections are made by internal switch contacts.

For example, in the 120/208V, 3-phase position, the switch will make the following connections:

T1-T7=L1

T2-T8=L2

T3-T9=L3

T4-T5-T6-T10-T11-T12=L0

This connects the main windings into the Low Wye configuration shown in the chart and provides 120VAC when measured line-to-neutral and 208VAC measured line-to-line. Similar connections are made for the other two positions of the selector switch.

G 25/50/70/85/125/160		20A GFI	30A Twist lock	50A Twist lock
<p>High Wye</p>	<p> <math>L1-L2 = 480V</math> <math>L1-N = 277V</math>  <math>L2-L3 = 480V</math> <math>L2-N = 277V</math>  <math>L3-L1 = 480V</math> <math>L3-N = 277V</math>                      N-  </p>	*139V	*139/240V	*139/240V
<p>Low Wye</p>	<p> <math>L1-L2 = 208V</math> <math>L1-N = 120V</math>  <math>L2-L3 = 208V</math> <math>L2-N = 120V</math>  <math>L3-L1 = 208V</math> <math>L3-N = 120V</math>                      N-  </p>	120V or *139V	120/208V or *139/240V	120/208V or *139/240V
<p>Zig Zag</p>	<p> <math>L1-L3 = 240V</math>  <math>L1-N = 120V</math>  <math>L2-N = ---</math>  <math>L3-N = 120V</math> </p>	120V	120/240V	120/240V

wc\_gr002767

\* Do not use GFI receptacles because GFI receptacles are only rated to 135V. Use care when using generator with selector switch in this position; 139V may damage certain tools. If 3-phase load can be operated at lower voltage, turn the voltage adjusting rheostat on control panel down—this will lower the GFI and line to neutral voltage as well. For example, 480V turned to 460V also reduces the GFI voltage from 139V to 133V.

See Graphic: wc\_gr002775

**Terminal Lugs and Receptacles**

The main connection lugs, labeled L1, L2, L3, and N are connected through the main circuit breaker (b) and then the voltage selector switch (a) back to the main stator windings. These lugs provide the primary connection points for attachment of outside loads. Power to the receptacles (c and d) is provided by direct line connections originating from the T7 and T9 leads from the VSS/generator and then to individual circuit breakers (e and f).

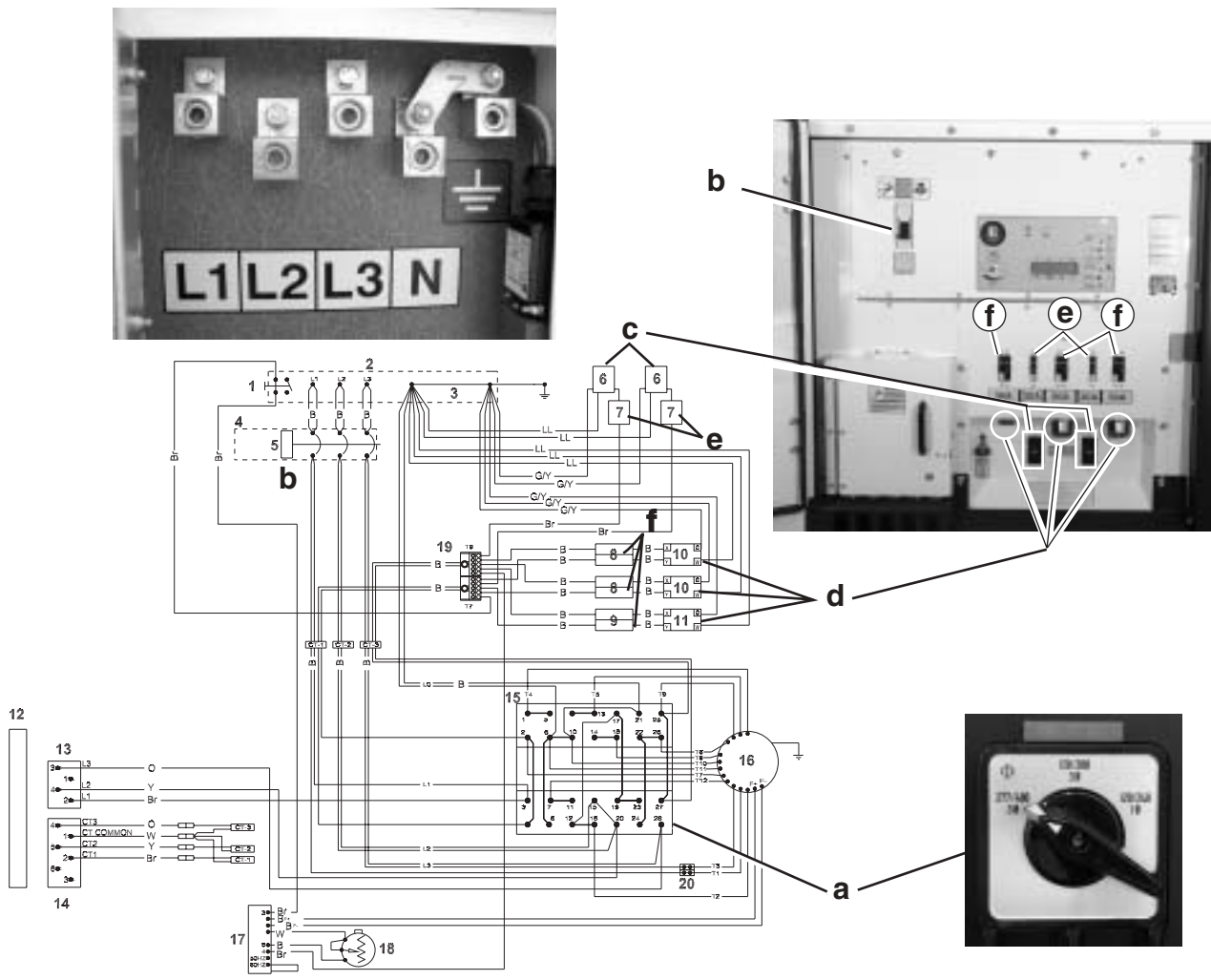

wc\_gr002775

4.7 Voltage Regulation

See Graphic: *wc\_gr002776* and *wc\_gr002777*

The Automatic Voltage Regulator (AVR) **(a)** is an encapsulated electronic control device that is rectangular in shape and located inside the control box on the right side wall. Its function is to maintain constant generator voltage over varying load conditions. The voltage regulator controls generator voltage by sensing AC voltage from the main stator winding at terminals 3 and 4. The voltage is passed through a full-wave Silicon Controlled Rectifier (SCR) circuit to supply DC output at the field terminals F+ and F-. The DC output controls the field strength of the exciter stator winding. A 4-Amp, 250-Volt, 5 x 20 mm, slow-blow fuse **(b)** protects the regulator. It is located on the regulator next to the terminal strip. The regulator will not work if the fuse is bad or missing.

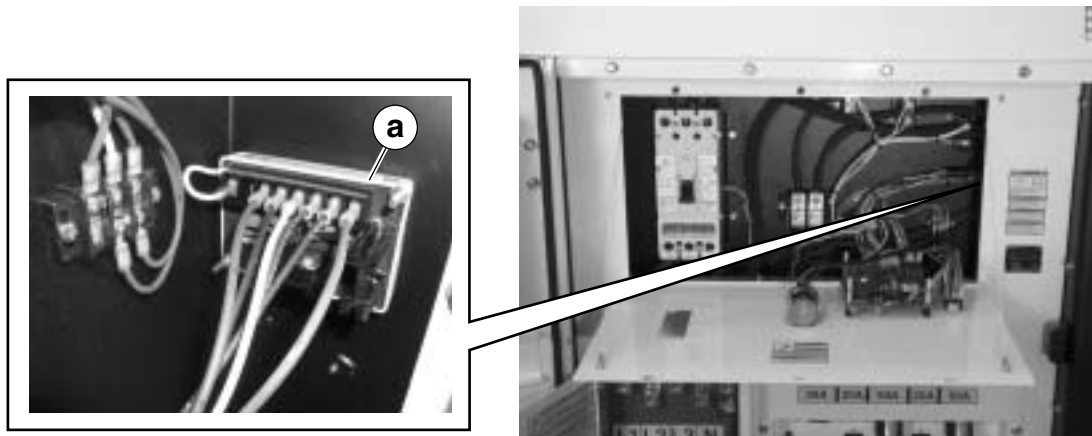

wc\_gr002776

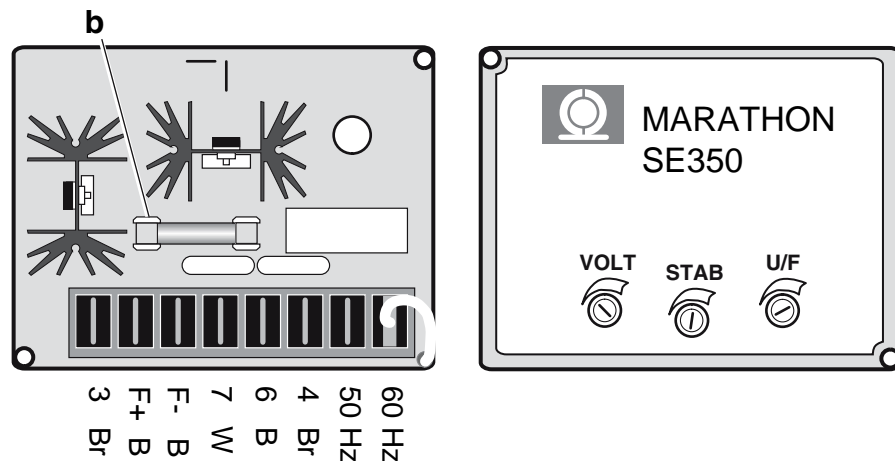

wc\_gr002777

See Graphic: wc\_gr0002778

### Regulator Makeup

There are eight terminals on the regulator labeled 3, 4, F+, F-, 6, 7, 50 Hz, and 60 Hz.

**Note:** A new replacement regulator comes with a jumper across terminals 6 and 7 which must be removed before the regulator is used.

- Terminals 3 and 4

Brown stator wires T7 and T9 are connected to regulator terminals 3 and 4 respectively, for all voltage selector switch positions. Voltage on terminals 3 and 4 will be either 208VAC or 240VAC depending on the voltage selector position. This input AC voltage is used for the AVR power supply and the regulator feedback information from the generator's output voltage. Wire T7 runs through the lug door interlock switch in the output lug box before connecting to regulator terminal 3. If the lug door is opened, power to the regulator is eliminated and only residual voltage (30VAC) will remain from the generator.

**Note:** The lug door interlock switch will also open the main circuit breaker disconnecting all the power to the lugs. However, the receptacles will still have residual voltage.

- Terminals F+ and F-

Black exciter stator wires are connected to regulator terminals F+ and F-. The regulator will supply between 10–73VDC to the stator exciter windings as required to maintain the correct AC generator output voltage.

- Terminals 6 and 7

Black and white wires from the remote voltage adjustment rheostat connect to terminals 6 and 7, respectively. The rheostat allows fine AC generator output voltage adjustment from the front control panel. Voltage adjustments must be made whenever the voltage selector switch is changed from or to the 208-Volt position. The remote rheostat must also be used if 240VAC 3-phase generator output is desired.

**Note:** If the line to line (L–L) voltage is increased, the line to neutral (L–N) voltage increases also. If 208 Volts L–L is increased to 240 Volts L–L, the 120 Volts L–N voltage will increase to 139 Volts L–N.

- Terminals 50Hz and 60Hz

There is an white jumper wire connected (at the factory) to the 60Hz terminal. If 50Hz is required, the jumper will have to be moved to the 50Hz terminal. The position of this jumper tells the regulator where the coarse Under Frequency roll off (U/F) point is. On a 60Hz unit the U/F point is 58Hz. On a 50Hz unit the U/F point is 48Hz. The U/F setting protects the regulator, the generator windings, and the customer's load by turning OFF the regulator when the engine speed drops below 1740 rpm, which equals 58Hz or below 1440 rpm, which equals 48Hz.

- Pots "Volt", "Stab", and "U/F"

On the backside of the regulator there are three adjustment pots labeled: Volt, Stab, and U/F. These pots are accessible via the side wall of the control box located in the engine compartment. Remove the black tape to access them. See illustration for position of each pot.

The Volt pot is only adjusted when installing a new AVR; after that, a remote 2.5k Ohm voltage adjustment rheostat connected to terminals 6 and 7 is used. A remote voltage adjustment rheostat is standard on all Wacker mobile generators and is located on the front of the control panel.

**Note:** *The Stab and U/F pots are factory set. Under normal circumstances, no adjustments to these pots is necessary. Only adjust these pots if a problem is present.*

The Stab pot is used to increase or decrease the regulator response time to load changes (transients). If the Stability (Stab) is set too low, the regulator can begin to hunt, or cycle the DC output voltage to F+ and F- up and down. This will cause the generator AC voltage to cycle up and down (seen in job lights flickering, etc.).

The U/F pot is used to make fine adjustments to the Under Frequency roll off point (U/F). See U/F description in Terminals 50Hz and 60Hz above.

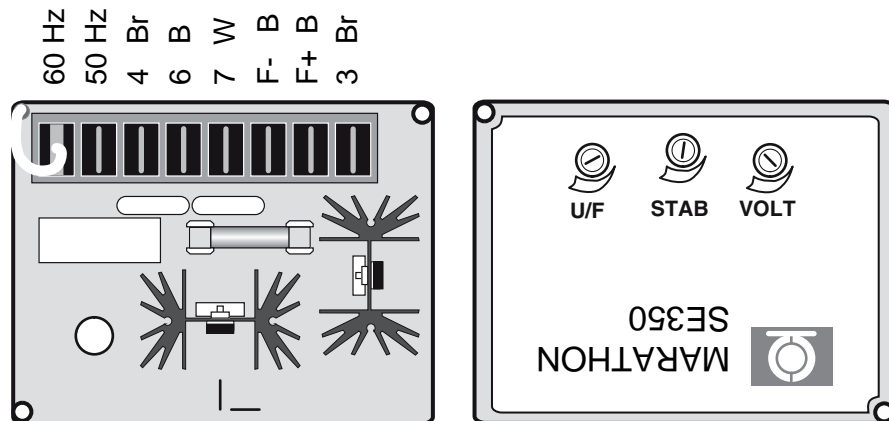

wc\_gr002778

See Graphic: wc\_gr002769

### Voltage Adjusting Rheostat

Generator output voltage can be adjusted using the 2.5k Ohm voltage adjusting rheostat (**a**). The 2.5k Ohm voltage adjusting rheostat is not part of the voltage regulator. It is connected to the regulator at terminals 6 and 7. The voltage adjustment range is +10% to -10% of the selected voltage.

**CAUTION:** Do not turn the voltage beyond 490VAC; damage to the excitation circuit will occur.

- 4.7.0.1 Make sure the main circuit breaker on the generator panel is open (off), and start the engine.
- 4.7.0.2 Allow the engine to run a few minutes until the engine speed stabilizes.
- 4.7.0.3 Check the AC voltage on the digital display panel. Turn the voltage adjustment screw right to increase voltage, left to decrease voltage.

**Note:** It will be necessary to adjust the voltage every time the voltage selector switch is changed to or from the 208-Volt position.

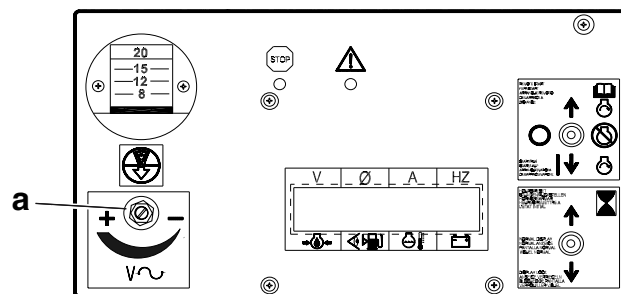

wc\_gr002769

## 4.8 Engine Start

Battery B+ wires provide 12VDC to the following locations on each generator:

- Isuzu-powered generators: starter motor, glow plug relay, starter relay, and terminal strip.
- John Deere without Engine Control Unit (ECU): starter motor, starter relay, terminal strip, alternator, and preheat relay.
- John Deere with ECU: ECU and terminal strip.

### Engine Start Switch

In the START/RUN position the engine start switch supplies power to the ECM through red #53 (B+) wire. This causes the module to go through its boot-up sequence which includes self-diagnostic checks, activation of the sensing circuits, and illumination of the display panel.

### Engine Control Module (ECM) Relays

The engine control module contains a crank relay, a fuel relay, and a preheat relay (not included on generators powered by John Deere engines with ECU). Red wire #18 connected to plug 2, pin 5 on the ECM provides 12VDC supply to contacts of the fuel and crank relays. This circuit is protected by a 10A fuse. Red wire #17 connected to plug 2, pin 7 on the ECM provides 12VDC to the contacts of the preheat relay.

When the start switch is in the START/RUN position, the ECM's crank relay is energized. On all models, the crank relay supplies 12VDC through yellow wire #63 to energize the starter relay. When the starter relay energizes, it supplies battery power to the engine starter motor solenoid which engages the starter motor to crank the engine. The crank relay on the control module remains energized for 10 seconds or until either the magnetic pick-up on the engine flywheel signals 100 rpm or the AC voltage input reaches 100VAC signifying the engine has started.

When the start switch is in the START/RUN position, the ECM's fuel relay is also energized. On Isuzu-powered generators, the ECM fuel relay supplies 12VDC through violet wire #64/#34 to energize the fuel pump relay. On John Deere (without ECU) powered generators, the ECM fuel relay supplies 12VDC through violet wire #64/#34 to energize the fuel solenoid. On John Deere (with ECU) powered generators, the ECM fuel relay supplies 12VDC through violet wire #64/#34 to power the ECU control circuits.

In the START/RUN position the ECM preheat relay will energize on the first of the three cranking cycles if coolant temperature (fuel temperature on John Deere powered generators) dictates. The ECM preheat relay supplies 12VDC through gray wire #65 to the glow plug relay on Isuzu-powered generators, intake air heater relay on John Deere (without ECU) powered generators. On John Deere engines with ECU, the ECU controls power to the intake air heater relay.

**Alternator**

On Isuzu-powered generators, the alternator is connected to the battery at the B+ terminal of the starter motor. On John Deere powered generators, the alternator is connected to the battery at the starter relay. The alternator supplies charging current to the battery while the engine is running.

## 4.9 ECM Monitoring System

### Operation

The ECM contains a microprocessor that monitors engine safety inputs. It protects the engine by automatically shutting it down in the event of low oil pressure, high coolant temperature, high engine speed, or low engine speed. The ECM is programmed at the factory and does not require any adjustment. The ECM also receives voltage and amperage input values from the generator and converts them to the digital readout displayed on its LCD panel. The ECM also monitors the current draw from the generator and will stop the engine if an overload is detected.

### Power Supply

When the engine start switch is switched to START/RUN or REMOTE START, 12VDC is applied to the ECM through the red wire connected to plug 1, pin 7. This is the main power supply to the ECM board. Electrical ground to the ECM is located at pin 8, next to pin 7.

### Oil Pressure

The ECM begins monitoring oil pressure 12 seconds after the engine starts and continues to monitor pressure until the engine is shutdown. The sensor is a variable resistor and the ECM monitors it via the white/blue wire plug 1, pin 3. If oil pressure falls below 15 psi, the ECM will recognize the fault and open the fuel relay circuit, stopping the engine.

### Coolant Temperature

The ECM begins monitoring engine coolant temperature immediately after it runs through its boot-up cycle. The sensor is a variable resistor that the ECM monitors through the yellow wire connected to plug 1, pin 5. The ECM recognizes the fault condition and opens the fuel relay when the engine temperature reaches 239°F (133°C) on John Deere engines and 221°F (123°C) on Isuzu engines. The coolant temperature sensor is located on the engine cylinder head near the thermostat.

### Underspeed / Overspeed

Engine under/overspeed protection is monitored from the frequency of an AC voltage generated every time a flywheel tooth passes under the magnetic pickup mounted to the engine flywheel housing. The frequency signal is transmitted to the ECM through the shielded black and clear wires connected to plug 1, pins 1 and 2.

The shutdown trip point is approximately 67Hz (2010 rpm) for overspeed and 55Hz (1650 rpm) for underspeed. If engine speed exceeds 67Hz or falls below 55Hz, the ECM opens the fuel relay circuit and stops the engine.

### **Overcrank**

The frequency signal is also used to determine an overcrank condition. If the ECM does not notice an increase in engine speed after three cycles of 10-seconds of crank followed by 10-seconds of rest, it terminates the crank attempts and displays an OVERCRANK message on the display panel. Placing the START/RUN switch to the OFF position will reset the ECM.

### **Fuel Gauge**

The sensor is a variable resistor that the ECM monitors through the white/violet wire at Plug 1, pin 12. If the input resistance climbs too high indicating a fuel level below 5%, the ECM opens the fuel relay circuit which de-energizes the fuel solenoid and shuts down the engine.

### **Voltmeter**

Line voltage values are transmitted to the ECM through the brown, yellow, and orange wires connected to plug 4. These wires are connected to the voltage selector switch.

See Graphic: wc\_gr002779

**Current Transformers**

Load line current values are provided by three current transformers (CT1, CT2, and CT3). Power lines to the main connection lugs and receptacles run through the current transformers. The current transformers sense line current and send an equivalent voltage to the ECM through the brown, yellow, white, and orange wires connected to plug 3. The ECM translates the incoming voltage into a digital readout showing current values for each phase leg of the generator.

A current overload on any leg will be recognized as a fault and the ECM will shut down the engine.

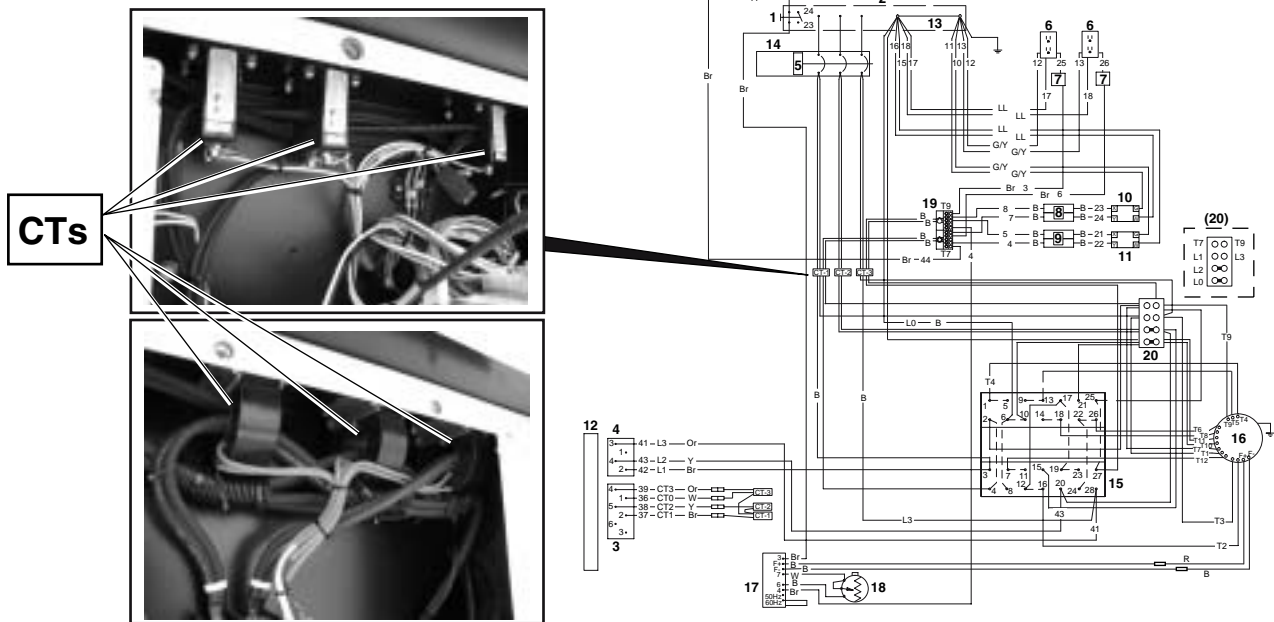

wc\_gr002779

5. ECM Troubleshooting

5.1 Normal Boot-up Sequence

During the boot-up sequence, the ECM scrolls through several screens before it settles into displaying the run screen. There are two different boot-up sequences depending on size of the generator and options included on the generator. Both of the boot-up sequences are listed below. When checking the boot-up sequence of your generator, be sure you are checking the one that matches your generator.

G 25, G 50, G 70, G 85 (9310)

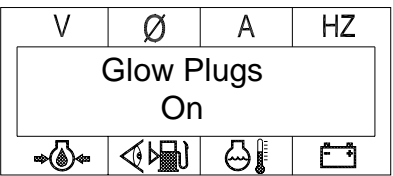
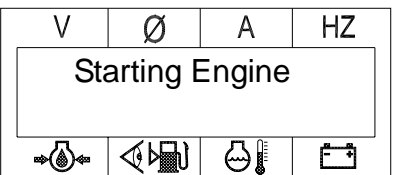
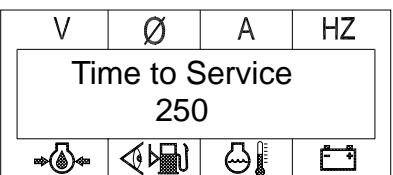
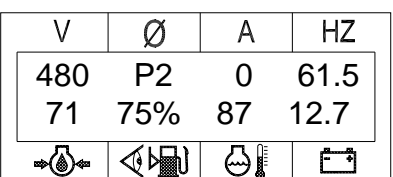
ECM Display	Description
	<p>Start of the boot-up sequence. The ECM shows that the glow plugs are on. The LED near the stop icon also illuminates. Note that the glow plugs are only on during the first of the three starting cycles.</p>
	<p>The ECM displays this screen when the starter is cranking the engine.</p>
	<p>The ECM displays the countdown time, in hours, until the next scheduled service. The timer starts at 250 and counts down to 0.</p>
	<p>At this point, the ECM displays the running values of the generator.  <b>Note:</b> The ECM display scrolls through each phase (P1, P2, P3) if in the 3-phase mode, or L1, L3, and L1 + L3 if in the single-phase mode.</p>

G 85 (9305), G 125, G 160

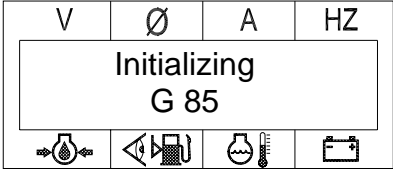
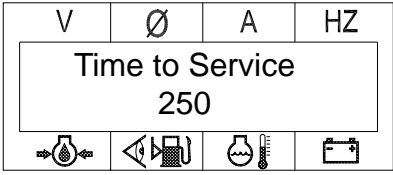
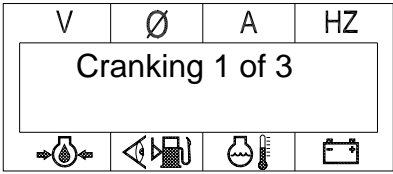
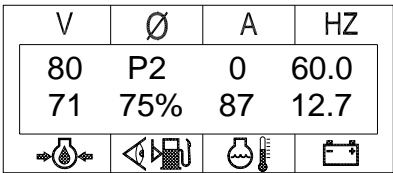
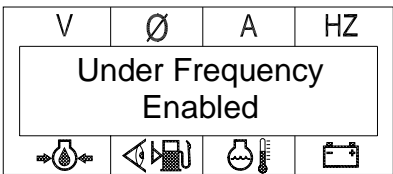
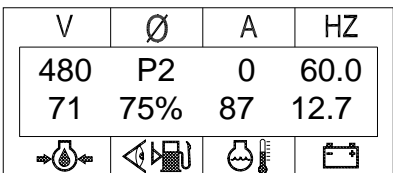
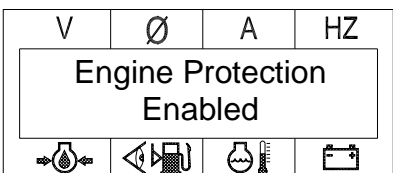
ECM Display	Description
 <p>V    Ø    A    HZ                      Initializing                      G 85</p>	<p>Start of the boot-up sequence. The ECM display reads “Initializing” and shows the model of the generator. If the model displayed does not match the model of the generator, call Wacker Service.</p>
 <p>V    Ø    A    HZ                      Time to Service                      250</p>	<p>The ECM displays the countdown time until the next scheduled service. The timer starts at 250 and counts down to 0.</p>
 <p>V    Ø    A    HZ                      Cranking 1 of 3</p>	<p>The ECM displays this screen during the first cranking cycle.</p>
 <p>V    Ø    A    HZ                      80   P2   0   60.0                      71   75%   87   12.7</p>	<p>The ECM displays this screen as soon as the engine starts. Note that some of the values such as voltage, may not be up to their running values at this stage of the sequence.</p>
 <p>V    Ø    A    HZ                      Under Frequency                      Enabled</p>	<p>The ECM displays this screen to let the operator know that the under frequency system (engine speed) has been enabled.</p>
 <p>V    Ø    A    HZ                      480   P2   0   60.0                      71   75%   87   12.7</p>	<p>At this point in the sequence, the ECM displays running values.</p>
 <p>V    Ø    A    HZ                      Engine Protection                      Enabled</p>	<p>The ECM displays this screen to let the operator know that the engine protection system has been enabled.</p>

<table border="1"> <tr> <td>V</td> <td>∅</td> <td>A</td> <td>HZ</td> </tr> <tr> <td colspan="4">AC Configuration</td> </tr> <tr> <td></td> <td></td> <td></td> <td></td> </tr> </table>	V	∅	A	HZ	AC Configuration								<p>The ECM displays the AC configuration as determined by the position of the voltage selector switch (VSS).</p>				
V	∅	A	HZ														
AC Configuration																	
<table border="1"> <tr> <td>V</td> <td>∅</td> <td>A</td> <td>HZ</td> </tr> <tr> <td colspan="4">Alt Protection Enabled</td> </tr> <tr> <td></td> <td></td> <td></td> <td></td> </tr> </table>	V	∅	A	HZ	Alt Protection Enabled								<p>The ECM displays this screen to let the operator know that the alternator protection system has been enabled.</p>				
V	∅	A	HZ														
Alt Protection Enabled																	
<table border="1"> <tr> <td>V</td> <td>∅</td> <td>A</td> <td>HZ</td> </tr> <tr> <td colspan="4">Rated Volts L to L</td> </tr> <tr> <td></td> <td></td> <td></td> <td></td> </tr> </table>	V	∅	A	HZ	Rated Volts L to L								<p>The ECM displays the line-to-line voltage. (This screen is shown for 3-phase VSS positions only.)</p>				
V	∅	A	HZ														
Rated Volts L to L																	
<table border="1"> <tr> <td>V</td> <td>∅</td> <td>A</td> <td>HZ</td> </tr> <tr> <td>480</td> <td>P2</td> <td>0</td> <td>60.0</td> </tr> <tr> <td>71</td> <td>75%</td> <td>87</td> <td>12.7</td> </tr> <tr> <td></td> <td></td> <td></td> <td></td> </tr> </table>	V	∅	A	HZ	480	P2	0	60.0	71	75%	87	12.7					<p>At this point, the ECM displays the run screen and the values for the main generator variables: voltage, phase* (leg), amperage, hertz (For generators with engines that include ECUs, the Hz reading will be 60.0. For all others the reading will be 61.5.) The ECM will also display the values for the main engine variables: oil pressure, fuel tank quantity, engine temperature, and battery voltage.</p> <p><b>*Note:</b> <i>The ECM display scrolls through each phase (P1, P2, P3) if in the 3-phase mode, or L1, L3, and L1 + L3 if in the single-phase mode.</i></p>
V	∅	A	HZ														
480	P2	0	60.0														
71	75%	87	12.7														

## 5.2 Display Variables and Values

See Graphic: *wc\_gr002944*

- Generator Variables

The values shown in the top line of the ECM display are all variables from the generator side of the machine. They are:

- (1) voltage (V)
- (2) phase ( $\emptyset$ ) (or leg for single phase)
- (3) amperage (A)
- (4) frequency(Hz).

- Engine Variables

The values shown in the lower line of the ECM display are all variables from the engine side of the machine. They are:

- (5) engine oil pressure (psi)
- (6) fuel tank quantity (shown in percentage of capacity)
- (7) engine temperature ( $^{\circ}$ F)
- (8) battery voltage (V)

- Blinking Values

When a value on the ECM display blinks on and off, it signifies that the variable (temperature, fuel capacity, etc.) is in a prealarm state. For example, the value for the temperature reading will blink when the temperature of the generator is below 23 $^{\circ}$ C (74 $^{\circ}$ F). This simply signifies that the manifold heater (or glow plugs) will be energized to aid in engine starting. The fuel capacity reading will blink when it is below 25%. This tells the operator that the generator will be requiring fuel soon. See Section *Additional Variables Monitored by the ECM*.

**Note:** *If your generator has a block heater, the temperature reading should not blink. If it does, check the block heater to make sure it is functioning properly.*

- ND, 0, or Blank Values

When a value on the ECM display reads ND, 0, or is blank, it signifies that there is no data available for the variable.

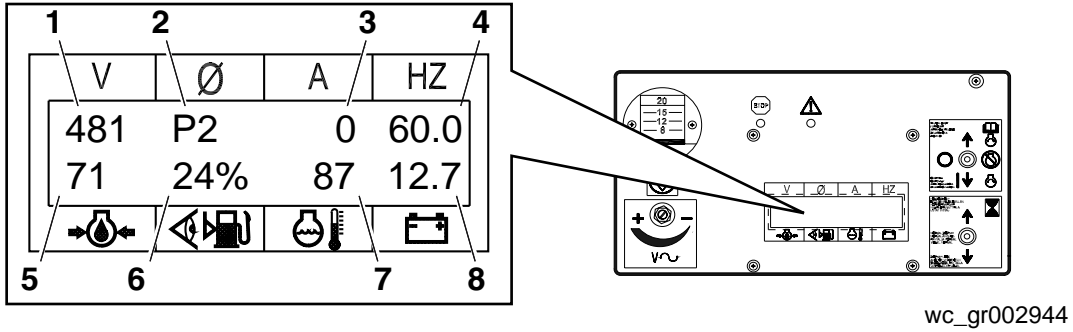

wc\_gr002944

### 5.3 ECM Display Screens—Start Switch in Remote Position

See Graphic: wc\_gr002943

When the start switch is placed in the REMOTE position, the following screens are displayed.

#### 5.3.1 Initializing

The ECM display reads “Initializing” and shows the model of the generator. If the model displayed does not match the model of the generator, call Wacker Service.

#### 5.3.2 Unit in Auto

The ECM displays “Unit in Auto” and the values for oil pressure, percentage of fuel remaining, engine temperature, and voltage of the battery.







wc\_gr002943

5.4 Additional Variables Monitored by the ECM

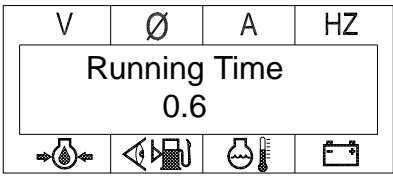
Holding the toggle switch in the HOURS/RESET position allows the operator to view additional variables monitored by the ECM. It also allows the time-to-service countdown timer to be reset. To reset the countdown timer, hold the toggle switch in the HOURS/RESET position for approximately 30 seconds or until all the screens have been scrolled through twice. There are three different sets of additional variables. Each of the following categories of generators has its own unique set: standard, those generators with cold weather packages or custom features, and those with the John Deere engine that includes the electronic Engine Control Unit (ECU). All three sets of additional variables are listed below, along with typical no load values. **Note:** *The values from your generator may differ slightly from those shown here.*

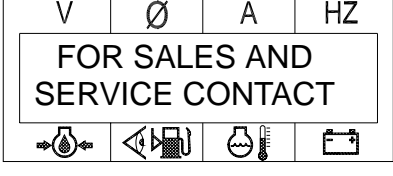
G 25, G 50, G 70, G 85 (9310) Standard Models

ECM Display	Description
	<p>The display shows the amount of time, in 1/10 hour segments, that the engine has been running.</p>
	<p>The display shows the amount of time left until service on the machine is required. To reset the timer to 250 hours, hold the Hours/Reset toggle switch in the up position until all the screens have been scrolled through twice.</p>
	<p>Some ECMs include this message.</p>
	<p>Some ECMs include this message.</p>

<p>The display shows the status of the oil pressure sender. If the oil pressure sender has failed, the time of the failure will be displayed. The time of the failure will be included in the display until the generator has been shut down and remains shutdown for a period of approximately two minutes.</p>	<p>The display shows the status of the oil pressure sender. If the oil pressure sender has failed, the time of the failure will be displayed. The time of the failure will be included in the display until the generator has been shut down and remains shutdown for a period of approximately two minutes.</p>
<p>The display shows the status of the engine coolant temperature sender. If the coolant temperature sender has failed, the time of the failure will be displayed. The time of the failure will be included in the display until the generator has been shut down and remains shutdown for a period of approximately two minutes.</p>	<p>The display shows the status of the engine coolant temperature sender. If the coolant temperature sender has failed, the time of the failure will be displayed. The time of the failure will be included in the display until the generator has been shut down and remains shutdown for a period of approximately two minutes.</p>

**G 25, G 50, G 85 (9310) Cold Weather and Custom Generators**

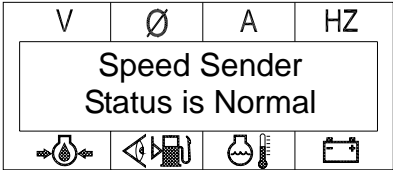
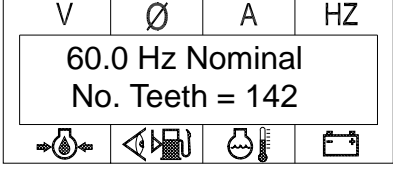
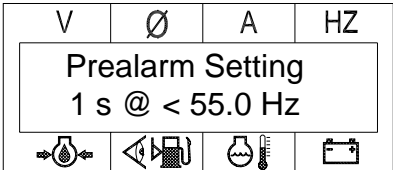
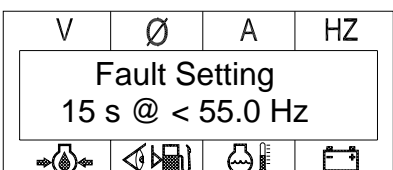
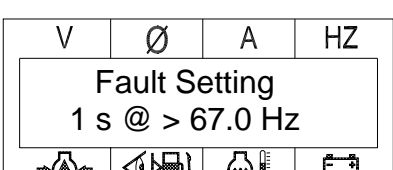
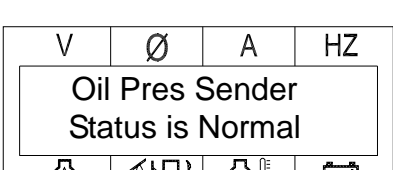
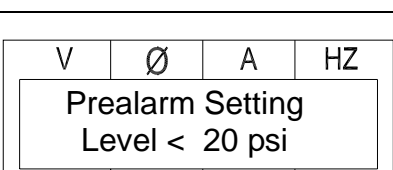

ECM Display	Description
	<p>The display shows the total time, in 1/10 hour increments, that the engine has been run. New machines, or machines with new ECMs, will read 0.0 or “No Data” because the engine has not been run for more than 1/10 of an hour.</p>
	<p>The display shows the amount of time left until service on the machine is required. To reset the timer to 250 hours, hold the Hours/Reset toggle switch in the up position until all the screens have been scrolled through twice.</p>
	<p>The display shows the date and job number data regarding the ECM manufacture.</p>
	<p>The display shows the AC configuration as determined by the position of the Voltage Selector Switch (VSS). If the machine is not running, the display reads “Unknown”.</p>
	<p>The ECM displays this screen to let the operator know that the alternator protection system has been enabled or disabled.</p>

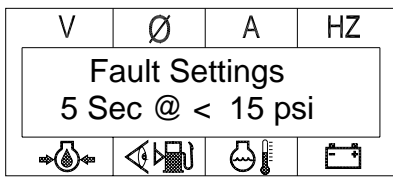
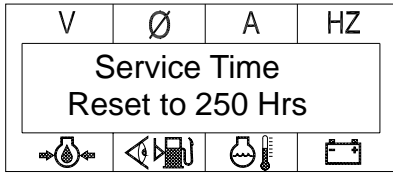
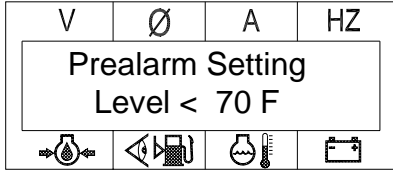
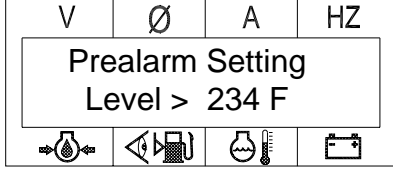
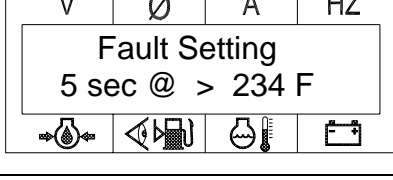
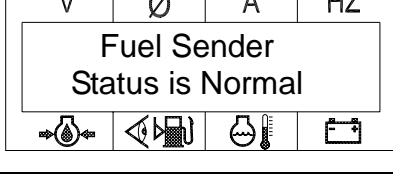
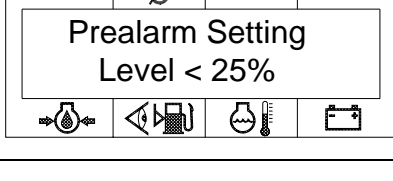
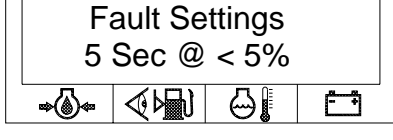
 <p>V   Ø   A   HZ</p> <p>Speed Sender Status is Normal</p> <p>Icons: Oil pressure, Fuel, Temperature, Battery</p>	<p>The display shows the status of the speed sender. If the speed sender has failed, the time of the failure will be displayed. The time of the failure will be included in the display until the generator has been shut down and remains shutdown for a period of approximately two minutes. At that time the ECM clears itself.</p>
 <p>V   Ø   A   HZ</p> <p>60.0 Hz Nominal No. Teeth = 142</p> <p>Icons: Oil pressure, Fuel, Temperature, Battery</p>	<p>The display shows the number of teeth on the flywheel which are measured by the magnetic pickup. The number of teeth differs between Isuzu engines (136) and John Deere engines (142).</p>
 <p>V   Ø   A   HZ</p> <p>Prealarm Setting 1 s @ &lt; 55.0 Hz</p> <p>Icons: Oil pressure, Fuel, Temperature, Battery</p>	<p>The display shows the value of the prealarm setting for under speed. If the ECM detects that the engine speed is less than 55 Hz for longer than 1 second, the Hz reading on the run screen will start to blink.</p>
 <p>V   Ø   A   HZ</p> <p>Fault Setting 15 s @ &lt; 55.0 Hz</p> <p>Icons: Oil pressure, Fuel, Temperature, Battery</p>	<p>The display shows the value of the fault setting for under speed. If the ECM detects that the engine speed is less than 55 Hz for longer than 15 seconds, the ECM will shut down the generator.</p>
 <p>V   Ø   A   HZ</p> <p>Fault Setting 1 s @ &gt; 67.0 Hz</p> <p>Icons: Oil pressure, Fuel, Temperature, Battery</p>	<p>The display shows the value of the fault setting for over speed. If the ECM detects that the engine speed is more than 67 Hz for longer than 15 seconds, the ECM will shut down the generator.</p>
 <p>V   Ø   A   HZ</p> <p>Oil Pres Sender Status is Normal</p> <p>Icons: Oil pressure, Fuel, Temperature, Battery</p>	<p>The display shows the status of the engine oil pressure sender. If the oil pressure sender has failed, the time of the failure will be displayed. The time of the failure will be included in the display until the generator has been shut down and remains shutdown for a period of approximately two minutes.</p>
 <p>V   Ø   A   HZ</p> <p>Prealarm Setting Level &lt; 20 psi</p> <p>Icons: Oil pressure, Fuel, Temperature, Battery</p>	<p>The display shows the value of the prealarm setting for low oil pressure. If the ECM detects that the engine oil pressure is less than 20 psi, the engine oil pressure reading on the run screen will start to blink.</p>

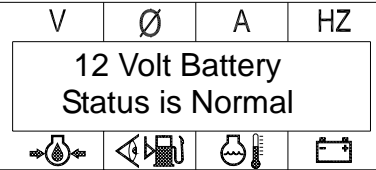
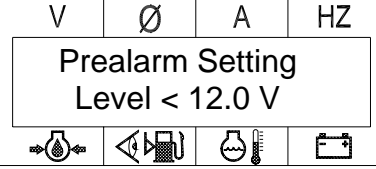
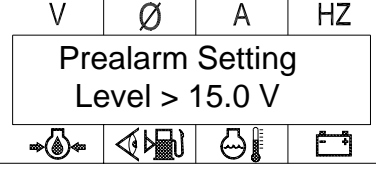
	<p>The display shows the value of the fault setting for low oil pressure. If the ECM detects that the engine oil pressure is less than 15 psi for longer than 15 seconds, the ECM will shut down the generator.</p>
	<p>The display shows this screen if the time to service timer has been reset to 250 hours.</p>
	<p>The display shows the value of the prealarm setting for low engine temperature. If the ECM detects that the engine temperature is less than 70°F, the engine temperature reading on the run screen will blink.</p>
	<p>The display shows the value of the prealarm setting for high engine temperature. If the ECM detects that the engine temperature is greater than 234°F (218°F on Isuzu engines), the engine temperature reading on the run screen will blink.</p>
	<p>The display shows the value of the fault setting for high engine temperature. If the ECM detects that the engine temperature is greater than 239°F (221°F on Isuzu engines) for longer than 5 seconds, the ECM will shut down the generator.</p>
	<p>The display shows the status of the fuel sender. If the fuel sender has failed, the time of the failure will be displayed. The time of the failure will be included in the display until the generator has been shut down and remains shutdown for a period of approximately two minutes.</p>
	<p>The display shows the value of the prealarm setting for low fuel level. If the ECM sees that the fuel level has dropped below 25%, the fuel level reading on the run screen will start to blink.</p>
	<p>The display shows the value of the alarm setting for low fuel level. If the ECM sees that the fuel level is less than 5% for longer than 5 seconds, the ECM will shut down the generator.</p>

 <p>12 Volt Battery Status is Normal</p>	<p>The display shows the status of the battery. When the battery voltage is within its “normal” range, 12 –15V, the ECM displays the voltage value in 1/10V increments on the run screen.</p>
 <p>Prealarm Setting Level &lt; 12.0 V</p>	<p>The display shows the battery low-voltage prealarm setting. When the ECM detects that battery voltage is less than 12V, the battery voltage reading on the run screen will blink.</p>
 <p>Prealarm Setting Level &gt; 15.0 V</p>	<p>The display shows the battery high-voltage prealarm setting. When the ECM detects that battery voltage is greater than 15V, the battery voltage reading on the run screen will blink.</p>

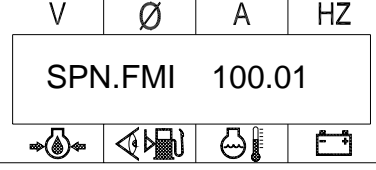
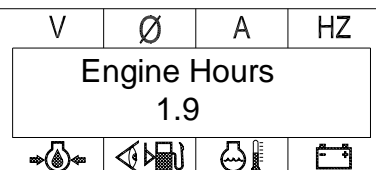
## G 85 (9305), G 125, G160 John Engines with ECU

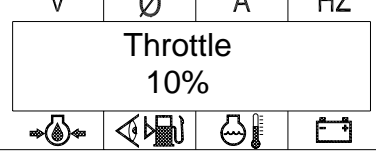
ECM Display	Description
 <p>SPN.FMI 100.01</p>	<p>John Deere engine diagnostic codes. SPN = Suspect Parameter Number FMI = Failure Mode Identifier. The ten most recent codes will be displayed from most current to least current. See the John Deere engine manual for details.</p>
 <p>Engine Hours 1.9</p>	<p>The display shows total time, in 1/10 hour increments, that the engine has been run. New machines, or machines with new ECMs, will read “No Data” because the engine has not been run for more than 1/10 of an hour.</p>
 <p>Time to Service 250</p>	<p>The display shows the amount of time left until service on the machine is required. To reset the timer to 250 hours, hold the Hours/Reset toggle switch in the up position until all the screens have been scrolled through twice.</p>
 <p>Throttle 10%</p>	<p>The display shows the amount the throttle is open at the current point in time.</p>

<table border="1"> <tr> <td>V</td> <td>Ø</td> <td>A</td> <td>HZ</td> </tr> <tr> <td colspan="4">Load @RPM 15%</td> </tr> <tr> <td></td> <td></td> <td></td> <td></td> </tr> </table>	V	Ø	A	HZ	Load @RPM 15%								<p>The display shows the present load on the engine. For no load conditions (generator not powering any outside tools or equipment) the display will read 15%.</p>
V	Ø	A	HZ										
Load @RPM 15%													
<table border="1"> <tr> <td>V</td> <td>Ø</td> <td>A</td> <td>HZ</td> </tr> <tr> <td colspan="4">Engine Torque 60%</td> </tr> <tr> <td></td> <td></td> <td></td> <td></td> </tr> </table>	V	Ø	A	HZ	Engine Torque 60%								<p>The display shows the percentage of total engine torque being used.</p>
V	Ø	A	HZ										
Engine Torque 60%													
<table border="1"> <tr> <td>V</td> <td>Ø</td> <td>A</td> <td>HZ</td> </tr> <tr> <td colspan="4">Fuel Temperature 86° F</td> </tr> <tr> <td></td> <td></td> <td></td> <td></td> </tr> </table>	V	Ø	A	HZ	Fuel Temperature 86° F								<p>The display shows, in °F, the temperature of the fuel.</p>
V	Ø	A	HZ										
Fuel Temperature 86° F													
<table border="1"> <tr> <td>V</td> <td>Ø</td> <td>A</td> <td>HZ</td> </tr> <tr> <td colspan="4">Fuel Pressure 147</td> </tr> <tr> <td></td> <td></td> <td></td> <td></td> </tr> </table>	V	Ø	A	HZ	Fuel Pressure 147								<p>The display shows, in psi, fuel pressure.</p>
V	Ø	A	HZ										
Fuel Pressure 147													
<table border="1"> <tr> <td>V</td> <td>Ø</td> <td>A</td> <td>HZ</td> </tr> <tr> <td colspan="4">Fuel Rate 0.9 GPH</td> </tr> <tr> <td></td> <td></td> <td></td> <td></td> </tr> </table>	V	Ø	A	HZ	Fuel Rate 0.9 GPH								<p>The display shows, in gallons per hour (GPH), the rate at which fuel is being consumed.</p>
V	Ø	A	HZ										
Fuel Rate 0.9 GPH													
<table border="1"> <tr> <td>V</td> <td>Ø</td> <td>A</td> <td>HZ</td> </tr> <tr> <td colspan="4">Manifold Temp 95°F</td> </tr> <tr> <td></td> <td></td> <td></td> <td></td> </tr> </table>	V	Ø	A	HZ	Manifold Temp 95°F								<p>The display shows, in °F, the temperature of the engine intake manifold.</p>
V	Ø	A	HZ										
Manifold Temp 95°F													

5.5 CAN Bus Code Screen

For John Deere engines with electronic control (G 85, G 125, G160), the Engine Control Unit (ECU) communicates with the Engine Control Module (ECM) through a Controller Area Network (CAN). The wiring between the controllers forms a bus (physical electrical interface where many devices share the same electrical connections). When there is a communication malfunction between the ECU and the ECM, or when there is no data stored in the ECU, the ECM will display the following screen.

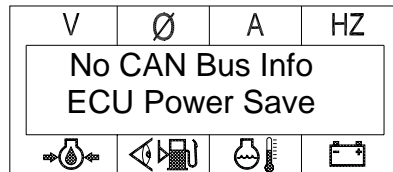

The ECU has diagnostic abilities and shares engine diagnostic information through codes which are displayed on the ECM display screen. These diagnostic codes are referred to as SPN/FMI codes: Suspect Parameter Number (SPN) and Failure Mode Identifier (FMI). SPN/FMI codes are conveyed in a two-part code number. The SPN typically contains between two and four digits and is the first number of the code. The FMI contains one or two digits and is the second number of the code. For example, if the ECM displays “SPN/FMI 100. 4”, The SPN “100” indicates a condition with the engine oil. FMI “4” indicates that the engine oil pressure input voltage is lower than the sensor’s specification—a condition associated with a disconnected oil pressure sensor. There are many such SPN/FMI codes. See the John Deere technical manual for more information.

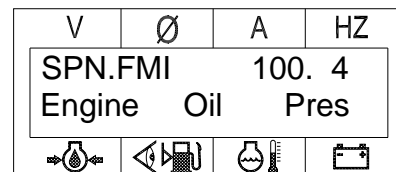

## 5.6 Voltage Display Errors

See Graphic: *wc\_gr002770*

- Single Phase Display Mode

The ECM is programmed to display line-to-line voltage values for both three-phase voltage selector switch positions. For example, if the voltage selector switch is in the 277/480V position, voltage values will read 480V on all three legs. However, when operating in the single phase 120/240V position, line-to-line voltage will only be displayed for leg 2 (240V). Legs 1 and 3 will display the line-to-neutral voltage of 120V. This is the normal single-phase display mode.

There are several conditions which can cause the ECM to switch to its single-phase display mode. The two most common conditions are described below. The voltage values displayed in this mode can lead someone to conclude that the generator is not running correctly.

Always check that display values are reading correctly before proceeding with more detailed troubleshooting procedures. If the voltage value on the ECM display is suspect, measure voltage values directly off the main connection lugs using a voltmeter. See section *Verifying Voltage*.

- Low Line Voltage in L2

If voltage in leg 2 (L2) drops below 50 Volts, the ECM will switch to its single-phase display mode and remain there. Two common causes for this are:

- Starting the generator with the connection lug door open and closing it afterward without turning off the engine.
- Starting the generator in its single-phase 120/240V position and switching to 120/208V or 277/480V three-phase without turning the generator off first.

Neither of the above conditions are recommended and both will cause the ECM to display a line-to-neutral voltage for legs 1 and 3. For example, in the 277/480V position leg 2 will read 480V while legs 1 and 3 will read 277V.

To change the ECM back to the three-phase display, close the lug door, then stop and restart engine.

- Engine Hour Switch in Locked Position

Another possible display error can occur when starting the machine with the engine hour switch **(a)** in its down or locked position. This position is normally used to lock the display onto a single leg and to prevent the display from scrolling through volt and amp values for all three legs.

On some generators, starting the engine with the switch in its locked (down) position will reverse the display for volts and amps. To correct the display, return the engine hour switch to its unlocked (scroll) position.

**To ensure the correct voltage display, make sure:**

- The connection lug door is closed and latched before starting the engine.
- The voltage selection switch is in its correct position prior to starting the engine.
- The engine hour switch is in its unlocked (center) position.

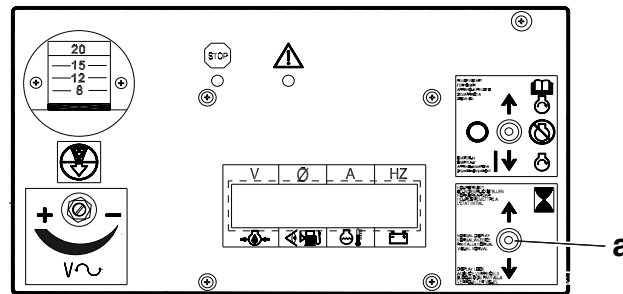

wc\_gr002770

## 5.7 ECM Automatic Engine Shutdown Conditions

The engine protection system includes six automatic shutdown conditions: low oil pressure, high coolant temperature, engine under/overspeed, engine overcrank, low fuel. The ECM will also shut down the engine if an over current condition exists.

When the ECM has shut down the unit due to one of the faults, the ECM will display the fault and other pertinent information to aid you in diagnosing the problem. **RECORD ALL THE INFORMATION LISTED** on the display, then refer to the following sections to diagnose and rectify the problem.

When the engine has shut down due to something outside the control of the ECM, the ECM will display “ENGINE STOPPED”.

### 5.7.1 Low Oil Pressure Shutdown

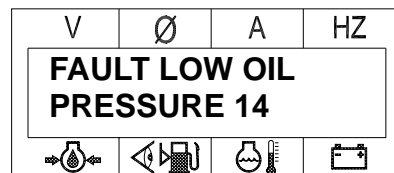

See Graphic: *wc\_gr001980, wc\_gr001981, wc\_gr002082*

When the ECM display reads “FAULT LOW OIL PRESSURE” or similar, it signifies a problem with engine oil pressure. During such a condition, the ECM will shut down the engine. If the ECM display reads less than 15 psi at shutdown, a problem exists with the engine. If the ECM message displays 15 psi or greater at shutdown, the problem lies within the ECM program.

To diagnose and rectify the fault:

- 5.7.1.1 Check the engine oil level using the dipstick. Add oil if necessary.
- 5.7.1.2 Carefully inspect the engine for oil leaks. If leaks exist, repair them or consult your Isuzu or John Deere dealer for repair work.
- 5.7.1.3 Remove and disconnect the oil pressure sender (**a**) from the engine. In its place, install an engine pressure gauge. Start the engine—*shut down the engine immediately if the oil pressure value does not read at least 15 psi.* Verify the oil pressure. If the pressure gauge reads the same as the ECM did at shutdown, there is a problem with the engine pressure. See an Isuzu or a John Deere dealer for repair work.

If the pressure gauge reads differently than the ECM, there is a problem with the sender or the ECM.

5.7.1.4 With a multimeter, check the continuity of the wire between the sender and the ECM. If the resistance measures “OL”, “OPEN”, or more than 1 Ohm, replace the wire.

5.7.1.5 Clean buildup from the end of the sender and check the sender’s resistance. A functioning sender will measure  $240 \pm 10$  Ohms outside of the engine.

If the sender does not measure  $240 \pm 10$  Ohms, replace it.

If the sender measures  $240 \pm 10$  Ohms, there may be a problem with the ECM.

5.7.1.6 Check the function of the ECM by attaching one end of a resistance of 100 Ohms to the oil pressure sender wiring and the other end to ground. This can be done by attaching a 100-Ohm resistor or potentiometer (pot). If you do not have a 100-Ohm resistor or a pot, an extra voltage adjustment rheostat similar to the one mounted on the control panel may be used. Calibrate the rheostat by attaching the leads of a multimeter to it and turning the rheostat’s adjusting knob. Mark the position of the knob at varying resistances. With a load of 100 Ohms, the ECM display should read approximately  $50 \pm 5$  psi. If it does not, replace the ECM or have it repaired. Contact Wacker for ECM repair details.

**Note:** *No testing of the oil pressure sensor can be done on John Deere engines with ECUs.*

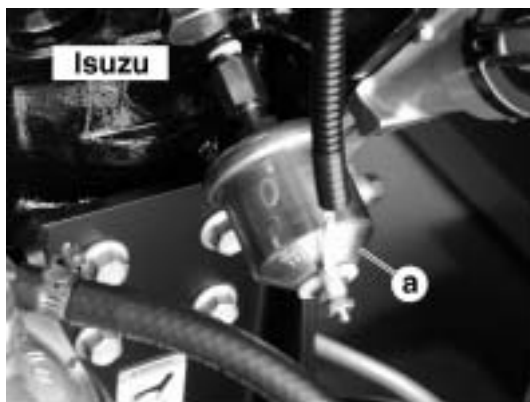

wc\_gr001980

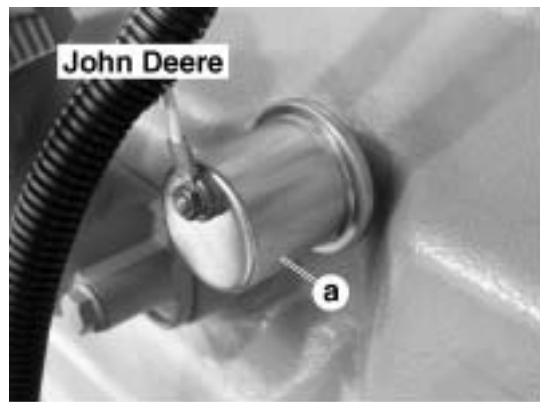

wc\_gr001981



wc\_gr002082

### 5.7.2 High Coolant Temperature Fault

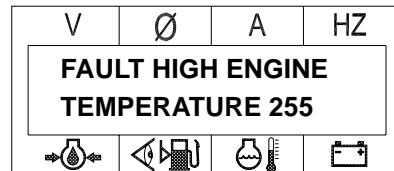

See Graphic: *wc\_gr001982*, *wc\_gr001983*, and *wc\_gr002083*

When the ECM display reads “FAULT HIGH ENGINE TEMPERATURE” or similar, it signifies that engine coolant temperature has risen above safe levels. The temperature at which the ECM will shut down the engine is 239°F (115°C) for John Deere engines, 221°F (105°C) for Isuzu engines. If the ECM displays less than 239°F (John Deere), 221°F (Isuzu) after shutdown, the problem exists within the ECM program.

**Note:** Normal engine operating temperature is between 170°–200°F (77°–93°C).

**Note:** The temperature sender must be fully immersed in liquid to function properly.

To diagnose and rectify fault:

- 5.7.2.1 Allow the engine to cool to a safe temperature then inspect the coolant level in the radiator. Add coolant as needed. Also inspect the coolant hoses and the engine block for leaks. Check the fan belt and the water pump.
- 5.7.2.2 With a multimeter, check the continuity of the wire between the sender **(a)** and the ECM. If resistance measures “OL”, “OPEN”, or more than 1 Ohm, replace the wire.
- 5.7.2.3 Clean the immersed end of the sender. Check the sender’s resistance. A functioning sender will measure 700–800 Ohms outside of the engine at room temperature.  
If the sender does not measure 700–800 Ohms, replace it.  
If the sender measures 700–800 Ohms, there may be a problem with the ECM.

5.7.2.4 Check the function of the ECM by attaching varying loads of resistance on one end of the temperature sender wiring and the other end to ground. This can be done by attaching varying resistors or through a potentiometer (an extra voltage adjustment rheostat similar to the one mounted on the control panel may be used.) Calibrate the rheostat by attaching the leads of a multimeter to it and turning the rheostat's adjusting knob. Mark the position of the knob at varying resistances. With a load of 700–800 Ohms, the ECM display should read 72°F; 30–40 Ohms=230°F; 175 Ohms=175°F. If the ECM does not respond accordingly, replace it or have it repaired. Contact Wacker for ECM repair details.

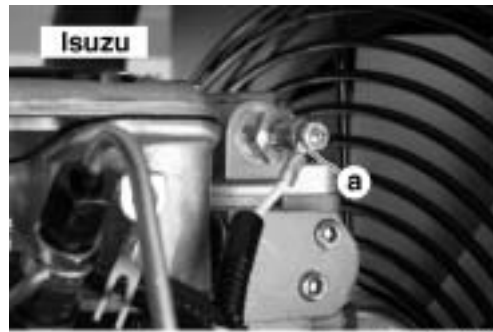

wc\_gr001983

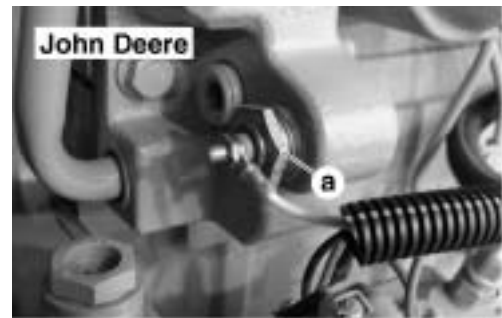

wc\_gr001982

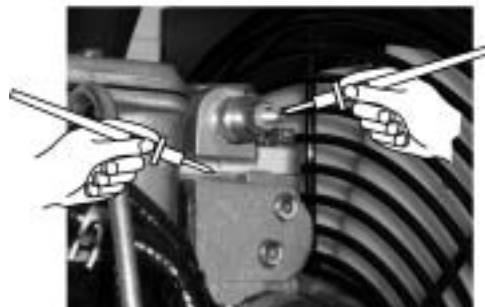

wc\_gr002083

## 5.7.3 Overspeed/Underspeed Shutdown Fault

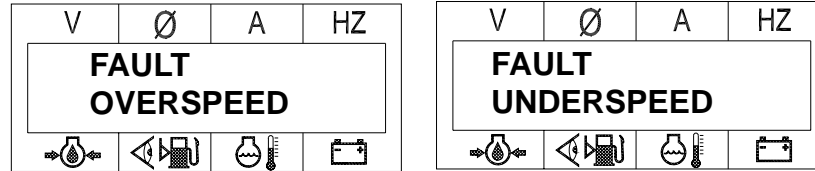

See Graphic: *wc\_gr001984* and *wc\_gr002780*

When the ECM display reads “FAULT OVERSPEED” or similar, it indicates that the engine speed exceeded approximately 2130 rpm (118% of its rated speed of 1800 rpm) and the ECM has automatically shut down the engine.

When the ECM display reads “FAULT UNDERSPEED” or similar, it indicates that the engine speed dropped below 55Hz (1650 rpm) for more than 15 seconds and the ECM has automatically shut the engine down.

To rectify an over- or under-speed condition:

- 5.7.3.1 For underspeed conditions check: system overload, condition of fuel system, condition of air, fuel, and oil filters.
- 5.7.3.2 For overspeed conditions check: governor speed setpoint, malfunctioning governor system and fuel supply entering air intake system.
- 5.7.3.3 For both under- and over-speed conditions, recalibrate the ECM frequency display. See *Recalibrating the ECM*.
- 5.7.3.4 Restart the engine and check the engine speed using a tachometer (Wacker tach PN 0154500) or vibrotach.
- 5.7.3.5 If the speed is incorrect, reset the engine rpm to approximately 1850 rpm no load. (Note:  $\text{rpm} \div 30 = \text{Hertz}$ ;  $\text{Hertz} \times 30 = \text{rpm}$ .  $1850 \div 30 = 61.6$  thus,  $1850 \text{ rpm} = 61.6 \text{ Hertz}$ )

To adjust engine speed:

On Isuzu engines, loosen the lock nut **(a)** and turn the adjusting screw **(b)**. On John Deere engines, adjust the low-speed adjusting screws **(c)** and the throttle **(d)** as needed.

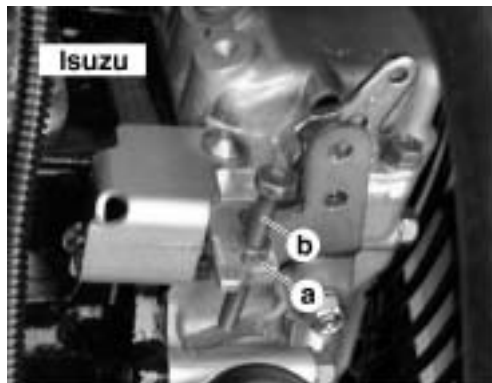

wc\_gr001984

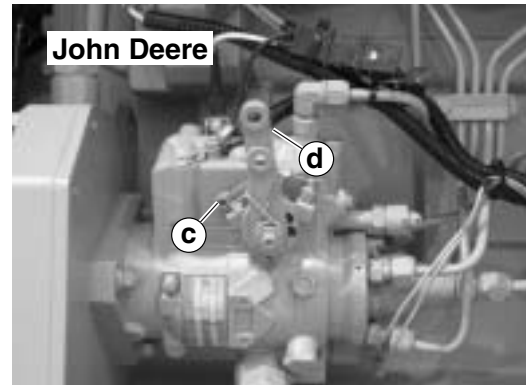

wc\_gr002780

## 5.7.4 Overcrank Shutdown Fault

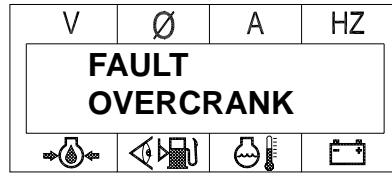

To rectify an overcrank condition, carry out the engine troubleshooting procedures found in this manual.

**Note:** An overcrank condition can occur even when the engine does not crank. This happens if a failure in one of the relays prevents the engine from cranking, allowing the ECM to time out. To reset the ECM, turn the start switch to OFF, then back to START/RUN, and retry starting the engine.

If the engine still does not start, refer to the engine manufacturer's operator's manual or service manual for possible engine problems.

## 5.7.5 Low Fuel Shutdown Fault

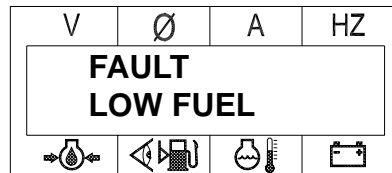

See Graphic: wc\_gr002084

A low fuel fault condition will be displayed when the fuel level drops to 5% of capacity and the ECM has shut down the engine. This fault condition prevents the fuel lines from running completely dry and avoids the need to bleed the lines when the tank is refilled.

To diagnose and rectify fault:

- 5.7.5.1 With a multimeter, check the continuity of the wire between the sender and the ECM. If resistance measures “OL”, “OPEN”, or more than 1 Ohm, replace the wire.
- 5.7.5.2 Remove and clean the sender. Check its resistance. A functioning sender will measure approximately 240 Ohms when the tank is empty; 33 Ohms when full.  
If the sender does not measure  $240 \pm 10\%$  Ohms in the empty position or  $33 \pm 10\%$  Ohms in the full position, replace it.  
If the sender measures  $240 \pm 10\%$  Ohms in the empty position,  $33 \pm 10\%$  Ohms in the full position and the ECM doesn't respond accordingly, there may be a problem with the ECM.
- 5.7.5.3 Check the function of the ECM by attaching varying loads of resistance to the fuel sender wiring. This can be done by attaching varying resistors or through a potentiometer. (An extra voltage adjustment rheostat similar to the one mounted on the control panel may be used.) Calibrate the rheostat by attaching the leads of a multimeter to it and turning the rheostat's adjusting knob. Mark the position of the knob at varying resistances. Then, connect the fuel sender wiring to the rheostat. With a load of 33 Ohms, the ECM display should read 104%; at approximately 210 Ohms, 15%. If the ECM doesn't respond accordingly, replace it or have it repaired. Contact Wacker for ECM repair details.

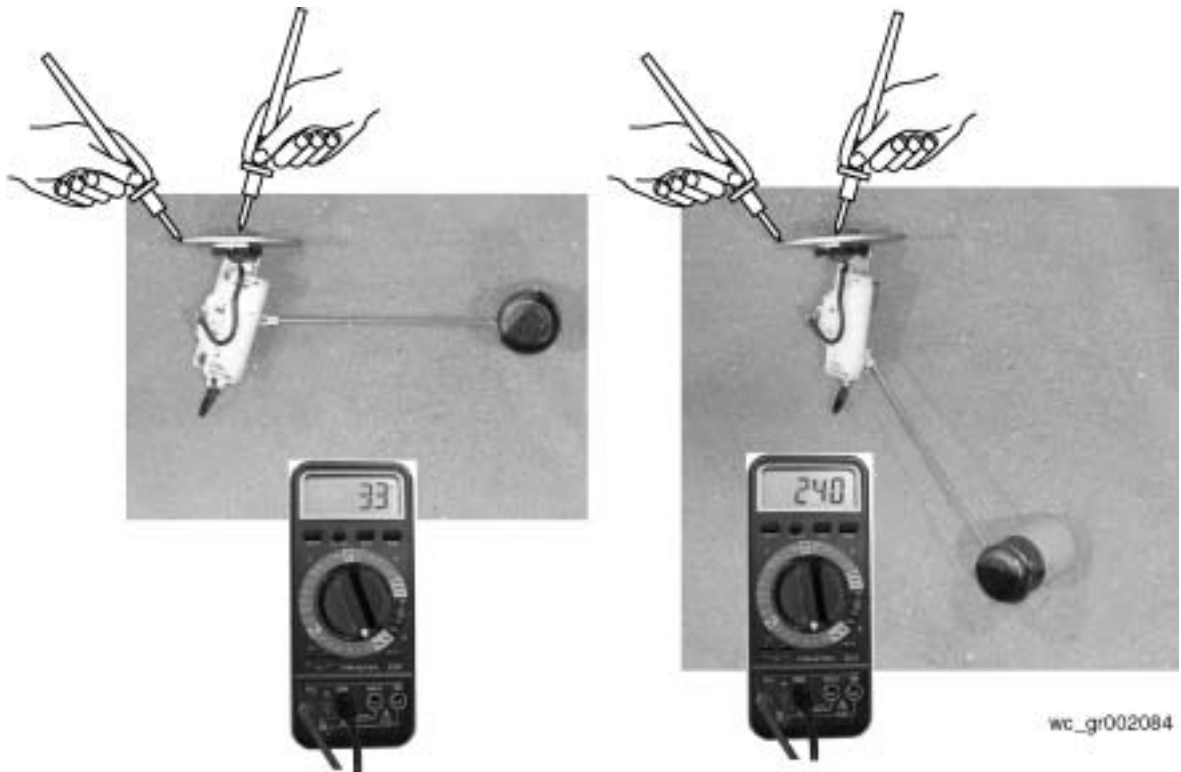

5.7.6 Over Current Shutdown Fault



Along with engine functions, the ECM continuously monitors the current load in each leg. The values for current overload are programmed into the ECM at the factory and are different for each generator size.

When an overload condition is sensed in any leg, the engine will shut down and the ECM displays “FAULT OVERLOAD” or similar.

Before restarting the generator, the cause of the overload should be determined and eliminated. Review all loads attached to the generator and make sure they do not exceed the power rating of the unit.

**Note:** Before any fault shutdown, the ECM display will show a “flashing” value and the yellow prealarm warning LED will come on. For example, during an overload condition the value of the amperage will flash. To aid in troubleshooting, make note of these values when a shutdown does occur.

## 5.8 Sender Failures

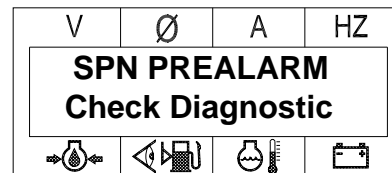
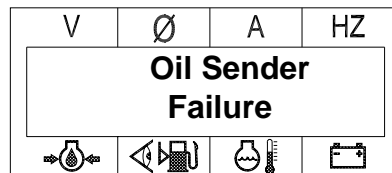

If one of the sensors should malfunction or become shorted to ground, the ECM LCD will display a message similar to one of those shown above. The yellow caution LED on the front of the control panel will also illuminate. The value for the variable may go blank. Check the wiring to the sensor and the sensor before using the generator.

## 5.9 Recalibrating the ECM

See Graphic: *wc\_gr002771*

There are four display values on the ECM that may be recalibrated: AC voltage, AC amperage, AC frequency, and DC battery voltage.

5.9.1 To recalibrate the ECM AC voltage display:

5.9.1.1 Place the voltage selector switch in the 120/208V, 3-phase position.

5.9.1.2 Start the generator and place one of the 50A receptacle circuit breakers **(a)** in the ON position.

5.9.1.3 Observe the ECM display panel **(b)** as it cycles through the voltage values for each leg. Place the hour meter switch **(c)** in the down position when the ECM display is showing the leg 1 value.

5.9.1.4



**DANGER**

Electric shock hazard. Use extreme care when checking voltage.

Insert the probes of a multimeter into the 50A receptacle as shown. The meter should read between 208–240V. Monitor the ECM display panel as adjustments are made. Open the control panel to gain access to the back of the ECM. Turn the voltage adjusting pot **(d)** clockwise to increase voltage, counterclockwise to decrease voltage, until the voltage on the ECM display matches that on your multimeter.

**Note:** *Once completed for 208V, all other voltages will be reset as well; no other recalibration for AC voltage will be necessary.*

5.9.1.5 Return the hour meter switch to its center position.

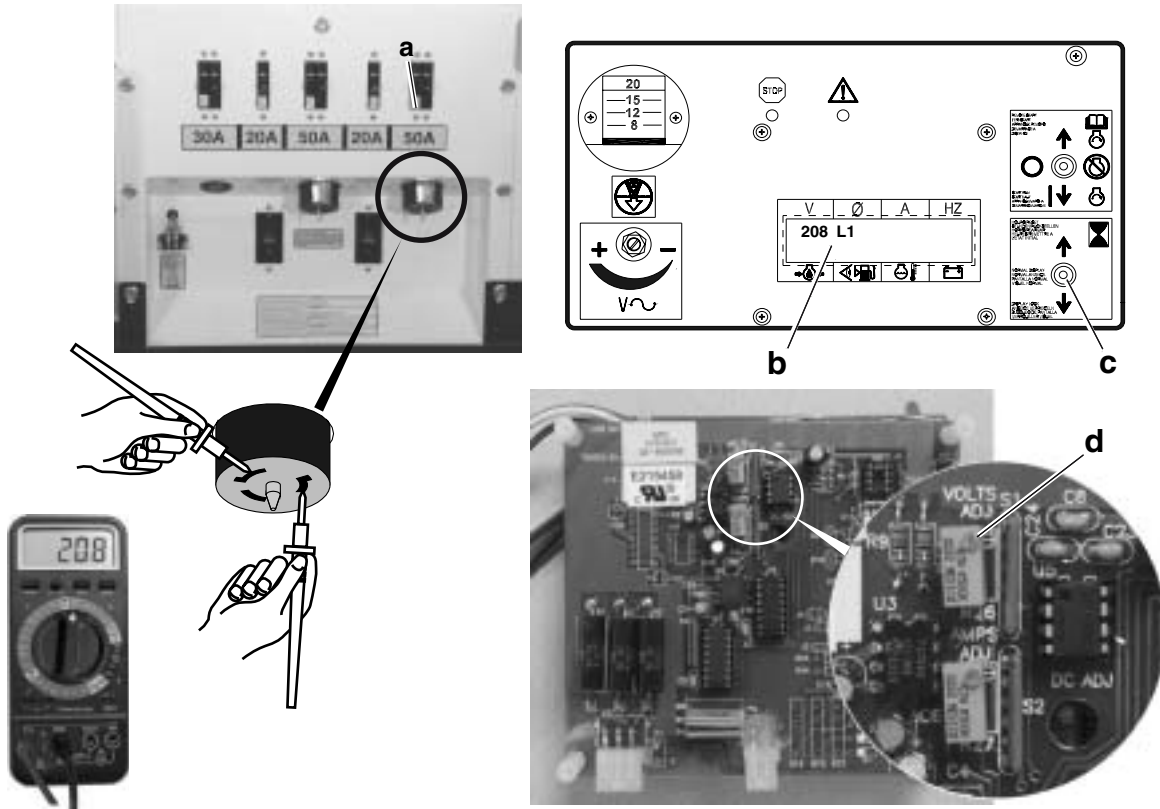

wc\_gr002771

See Graphic: wc\_gr002772

- 5.9.2 To recalibrate the ECM AC amperage display:
- 5.9.2.1 Start the generator and place one of the receptacle circuit breakers in the ON position. Plug in a load of 10A or greater on G12 and G25 models; 20A or greater on G50 and larger models. Or, connect an appropriately-sized load bank to the generator. Attach a clamp-type ammeter to one of the load wires (not more than one load wire or your readings will be inaccurate).
  - 5.9.2.2 Observe the ECM display panel **(a)** as it cycles through the amperage values for each leg. Place the hour meter switch **(b)** in the down position when the ECM displays an amperage value.
  - 5.9.2.3 Monitor the ECM display panel as adjustments are made. Open the control panel to gain access to the ECM. Turn the amperage adjusting pot **(c)** clockwise to increase, counterclockwise to decrease amperage until the amperage on the ECM display matches that on your multimeter amp clamp.

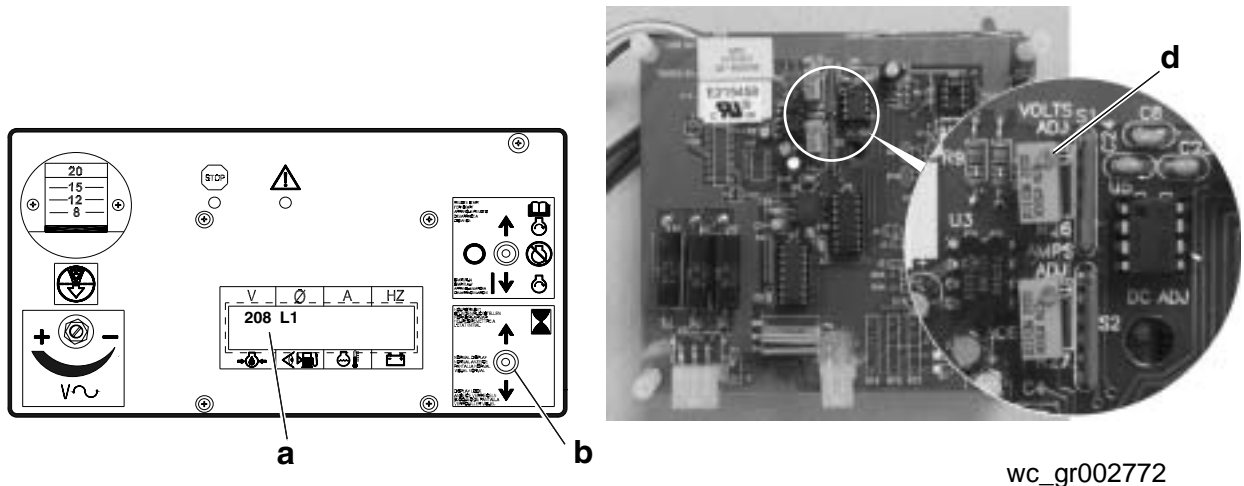

wc\_gr002772

See Graphic: wc\_gr002795

5.9.3 To recalibrate the ECM AC frequency (Hz) display:

**Note:** Recalibrate only if your unit is off by more than 5Hz.

5.9.3.1 Start the generator. Using a tachometer or vibrotach, adjust the engine speed to 1800 rpm or 60Hz.

5.9.3.2 Open the control panel to gain access to the ECM. Monitor the ECM display panel as adjustments are made.

5.9.3.3 Locate the AC frequency push button **(a)**. Hold the push button in until the ECM display reads 60Hz.

5.9.3.4 Set the engine speed back to 1850 rpm no load.

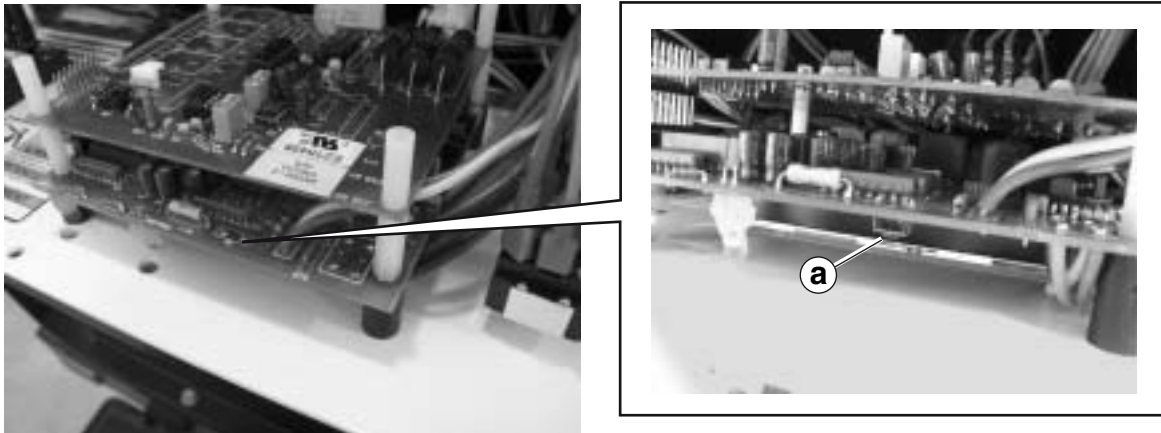

wc\_gr002795

See Graphic: *wc\_gr002796* and *wc\_gr002971*

### Isuzu and John Deere engines without ECU

- 5.9.4 To recalibrate ECM DC voltage (12V battery) display:
- 5.9.4.1 Start the generator. Open the control panel to gain access to the ECM. Monitor the ECM display panel as adjustments are made.
- 5.9.4.2 Using a multimeter, measure the voltage across the 12V machine battery. Adjust the DC voltage pot **(a)** by turning the adjusting screw so that the ECM reads the same value as the multimeter.
- Note:** *The pot is located on the lower ECM board. Access the pot through the hole in the upper board.*

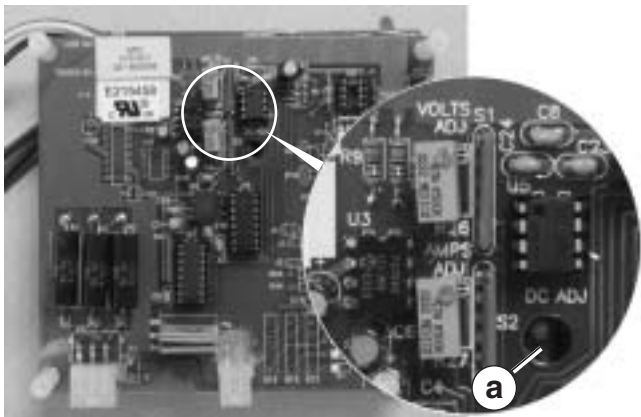

wc\_gr002796

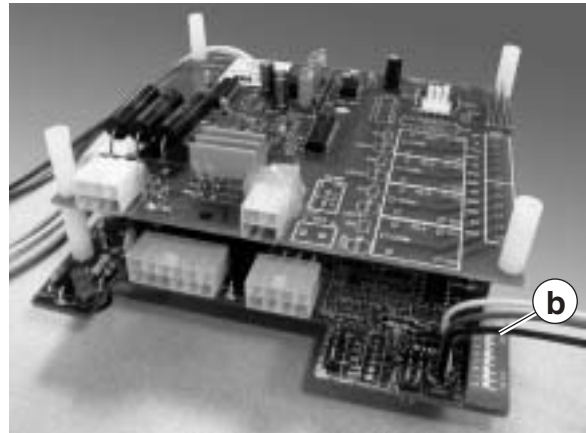

wc\_gr002971

### John Deere engines with ECU

- 5.9.5 To recalibrate ECM DC voltage (12V battery) display:
- 5.9.6 Measure the battery voltage. This procedure works best when the battery voltage is 12.6V.
- 5.9.6.1 Place the start switch in the REMOTE START position.
- 5.9.6.2 Open the control panel to gain access to the ECM.
- 5.9.6.3 Slide the number 2, Dual In-line Package (DIP) switch **(b)** to the ON position then back to the OFF position. The voltage display is now reset.

## 5.10 Removing and Installing the ECM

See Graphic: *wc\_gr002797*

Removal:

- 5.10.1 Remove the nut securing the hour meter switch **(a)** and the nut securing the start switch **(b)** to the panel.
- 5.10.2 Remove the screws **(c)** securing the ECM to the panel.
- 5.10.3 Disconnect the four harness plugs **(e)**.
- 5.10.4 Remove the three red wires **(d)** from the start switch. Remove the start switch, hour meter switch, and the ECM from the panel.

**Note:** Replacement ECMs include start and hour meter switches.

Installation:

- 5.10.5 Secure the ECM to the panel with screws **(c)**.
- 5.10.6 Secure the hour meter **(a)** and the start switch **(b)** to the control panel.
- 5.10.7 Reconnect the four harness plugs **(e)**.
- 5.10.8 Reinstall the three red wires **(d)** to the start switch.

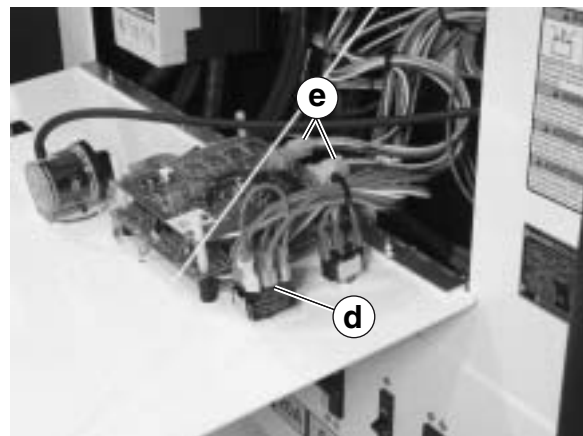
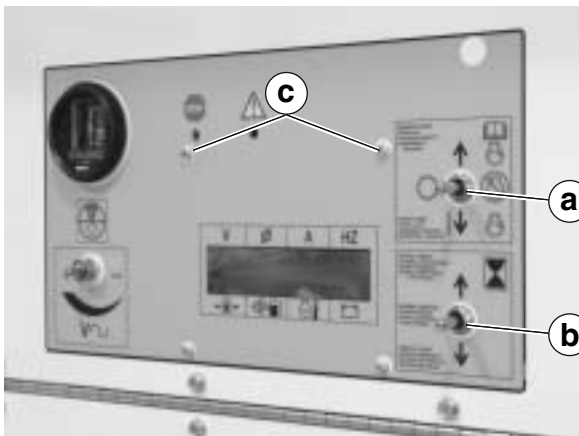

*wc\_gr002797*

5.11 ECM Circuit Boards

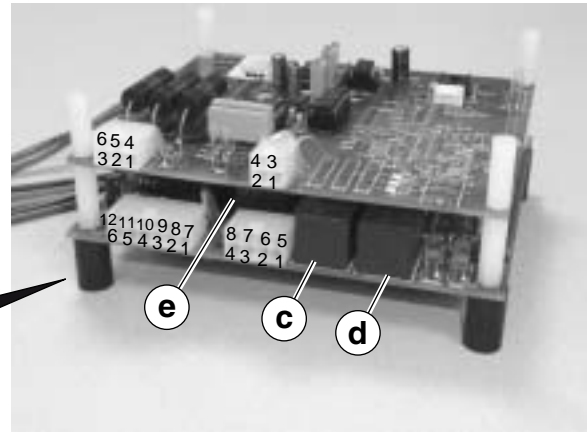
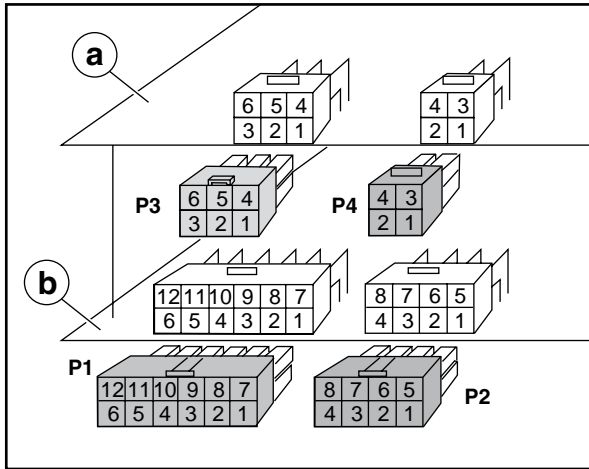

wc\_gr002924

**Note:** Your machine's ECM board may differ slightly from the one pictured.

Ref.	Description
a	AC board
b	Engine board
c	Crank relay
d	Fuel relay
e	Preheat relay
P1	Power and engine sensing
P2	Power to crank, fuel and fault prealarm closures
P3	AC Amps connection to current transformers
P4	AC Volts connection to voltage selector switch

5.12 Control Wiring Numbering & Colors

See Graphic: *wc\_gr002924*

Generator and control wires are marked and color coded to assist in tracing line connections and troubleshooting. The charts below list wire labels and colors followed by a description of their use.

<b>G 25 Control Module</b>		
<b>Plug 1: Engine Sender Inputs (12-pin connector)</b>		
1	Black	Magnetic pickup
2	Clear, shield	Magnetic pickup
3	White/Blue	Oil pressure sender
5	Yellow	Water temperature sender
7	Red	Run/Off/Auto switch, +12V (positive)
8	Black	12VDC supply, - ground (negative)
10	Orange	Remote start contacts
11	Red	Emergency stop pushbutton
12	White/Violet	Fuel level sender
<b>Plug 2: Engine Start Inputs/Outputs (8-pin connector)</b>		
1	Yellow/Red	Out; 12VDC to starter relay
2	Violet	Out; 12VDC to E-stop switch
5	Red	In; 12VDC from B+ through 10A fuse
7	Red	In; 12VDC from B+
8	Green	Out; 12VDC to glow plug relay
<b>Plug 3: Current Transformer Inputs (6-pin connector)</b>		
1	White	Ammeter line input CT common
2	Brown	Ammeter line input CT1
4	Orange	Ammeter line input CT3
5	Yellow	Ammeter line input CT2
<b>Plug 4: Line Voltage Inputs (4-pin connector)</b>		
2	Brown	Voltage line input L1 at volt selector #3

3	Orange	Voltage line input L3 at volt selector #28
4	Yellow	Voltage line input L2 at volt selector #20

<b>G 50/70/85 Control Module</b>		
<b>Plug 1: Engine Sender Inputs (12-pin connector)</b>		
1	Black	Magnetic pickup
2	Clear, shield	Magnetic pickup
3	White/Black	Oil pressure sender
5	Yellow	Water temperature sender
7	Red	Run/Off/Auto switch, +12V (positive)
8	Black	12VDC supply, - ground (negative)
10	Orange	Remote start contacts
11	Green	Emergency stop pushbutton
12	White/Violet	Fuel level sender
<b>Plug 2: Engine Start Input/Outputs (8-pin connector)</b>		
1	Yellow	Out; 12VDC to starter relay
2	Violet	Out; 12VDC to E-stop switch
5	Red	In; 12VDC from starter relay (B+) through 10A fuse
7	Red	In; 12VDC from starter relay (B+)
8	Green	Out; 12VDC to air intake heater relay
<b>Plug 3: Current Transformer Inputs (6-pin connector)</b>		
1	White	Ammeter line input CT common
2	Brown	Ammeter line input CT1
4	Orange	Ammeter line input CT3
5	Yellow	Ammeter line input CT2
<b>Plug 4: Line Voltage Inputs (4-pin connector)</b>		
2	Brown	Voltage line input L1 at volt selector #3
3	Orange	Voltage line input L3 at volt selector #28
4	Yellow	Voltage line input L2 at volt selector #20

<b>G 125/160 Control Module</b>		
<b>Plug 1: Engine Sender Inputs (12-pin connector)</b>		
3	White/Blue	Crank delay, preheat
5	-	-
7	Red	Run/Off/Auto switch, +12V (positive)
8	Black	12VDC supply, - ground (negative)
9	Orange	Remote start contacts
10	Gray	Emergency stop pushbutton
12	White/Violet	Fuel level sender
<b>Plug 2: Engine Start Input/Outputs (8-pin connector)</b>		
1	Yellow	Out; 12VDC to starter relay
2	Violet	Out; 12VDC to E-stop switch
5	Red	In; 12VDC from starter relay (B+) through 10A fuse
<b>Plug 3: Current Transformer Inputs (6-pin connector)</b>		
1	White	Ammeter line input CT common
2	Brown	Ammeter line input CT1
4	Orange	Ammeter line input CT3
5	Yellow	Ammeter line input CT2
<b>Plug 4: Line Voltage Inputs (4-pin connector)</b>		
2	Brown	Voltage line input L1 at volt selector #3
3	Orange	Voltage line input L3 at volt selector #28
4	Yellow	Voltage line input L2 at volt selector #20

5.13 Sender Resistance Graphs

5.13.1 Fuel Sender

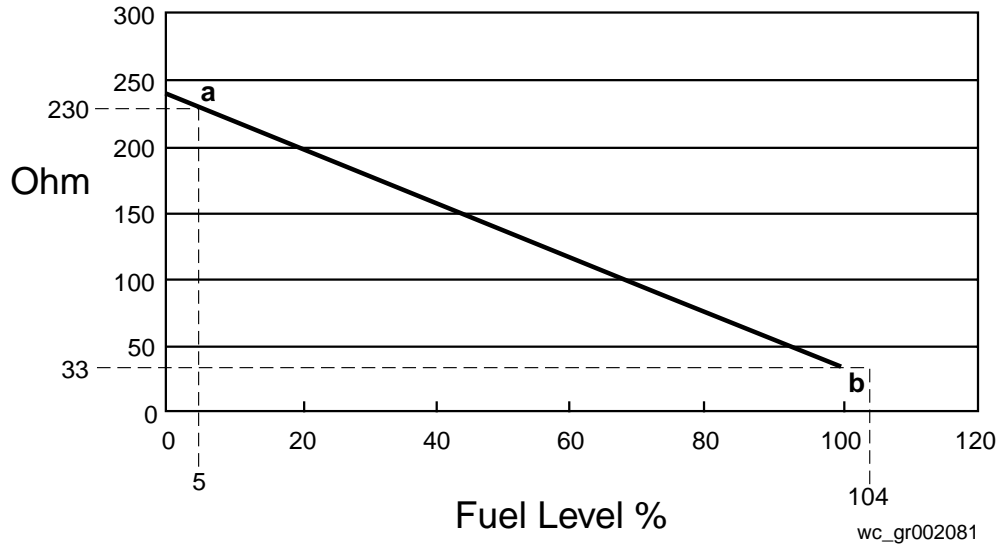

a = shutdown point, 5%

b = full, 104%

5.13.2 Oil Sender

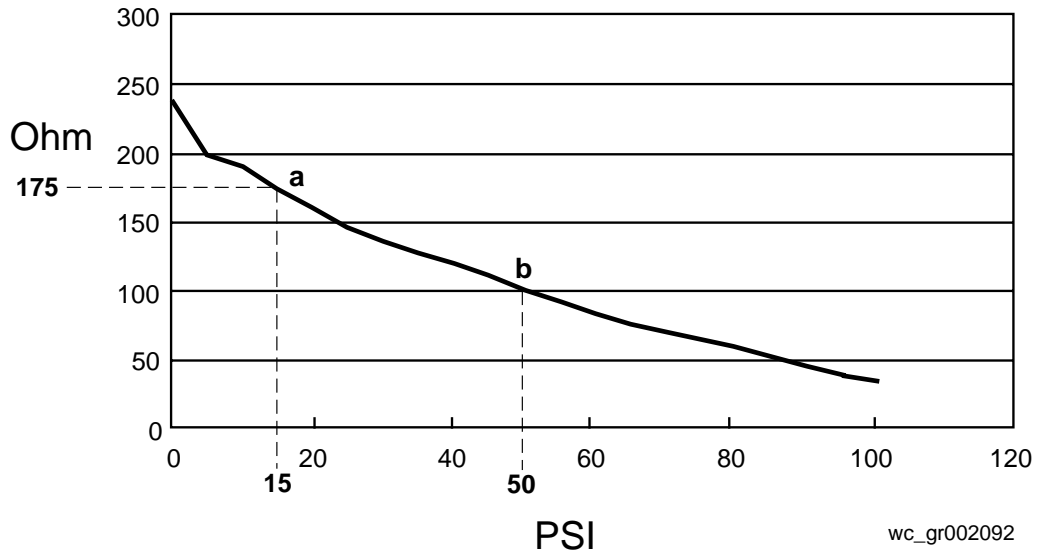

a = shutdown point, 175 psi (12 bar)

b = normal operating pressure, 50 psi (3.4 bar)

5.13.3 Temperature Sender

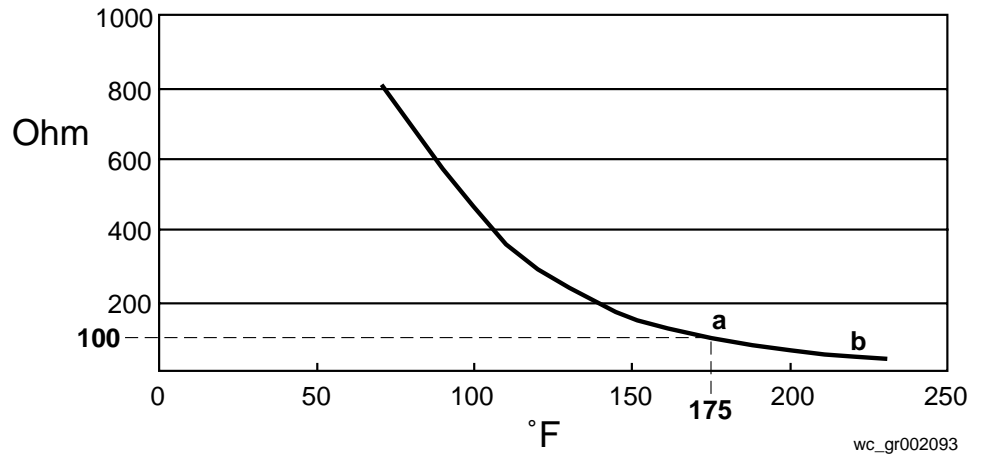

a = approximate normal operating temperature

b = approximate shut down temperature

## 5.14 Checking Magnetic Pickup

See Graphic: wc\_gr002114

The magnetic pickup is a magnet with a coil of wire wrapped around it. It sends an AC signal to the ECM when the engine turns. The ECM determines rpm by counting the AC voltage sine waves generated every time a flywheel tooth passes underneath the magnetic pickup. When the ECM sees that the engine has reached 100 rpm, the ECM discontinues cranking the starter motor.

- 5.14.1 Disconnect wiring **(a)** and remove the magnetic pickup **(b)** from the engine.
- 5.14.2 Using a multimeter, check the magnetic pickup for resistance. A functioning pickup will measure 650–700 Ohms.
- 5.14.3 When re-installing the magnetic pickup, thread the pickup in until it touches the teeth of the flywheel **(c)**. Then, back the magnetic pickup out 1/2 turn, hold it in place, and secure it with the nut **(d)**.



## 6. Isuzu Engine Troubleshooting

### 6.1 Isuzu Engine Background

See Graphic: *wc\_gr002003*

The Isuzu engines use individual cylinder glow plugs as a starting aid. An electric fuel lift pump and an electro-mechanical fuel solenoid are used for engine run/stop control.

The glow plugs are located near the top of the engine, and protrude into each cylinder, one per cylinder. The glow plugs warm the engine cylinder and aid in fuel/air mixture ignition when the engine is cold. They can reach temperatures up to 1200°F (649°C). After the start switch is moved into the START/RUN position, the red LED near the stop sign on the front of the control panel will be lit indicating the ECM is attempting to energize the glow plugs. The ECM controls the duration the glow plugs are energized based on the engine coolant temperature. The colder the temperature, the longer the glow plugs are energized. The glow plugs are energized only during the first of three automatic starting attempts.



wc\_gr002003

6.2 Engine Wiring Diagram—Isuzu

This schematic will be referred to throughout this chapter.

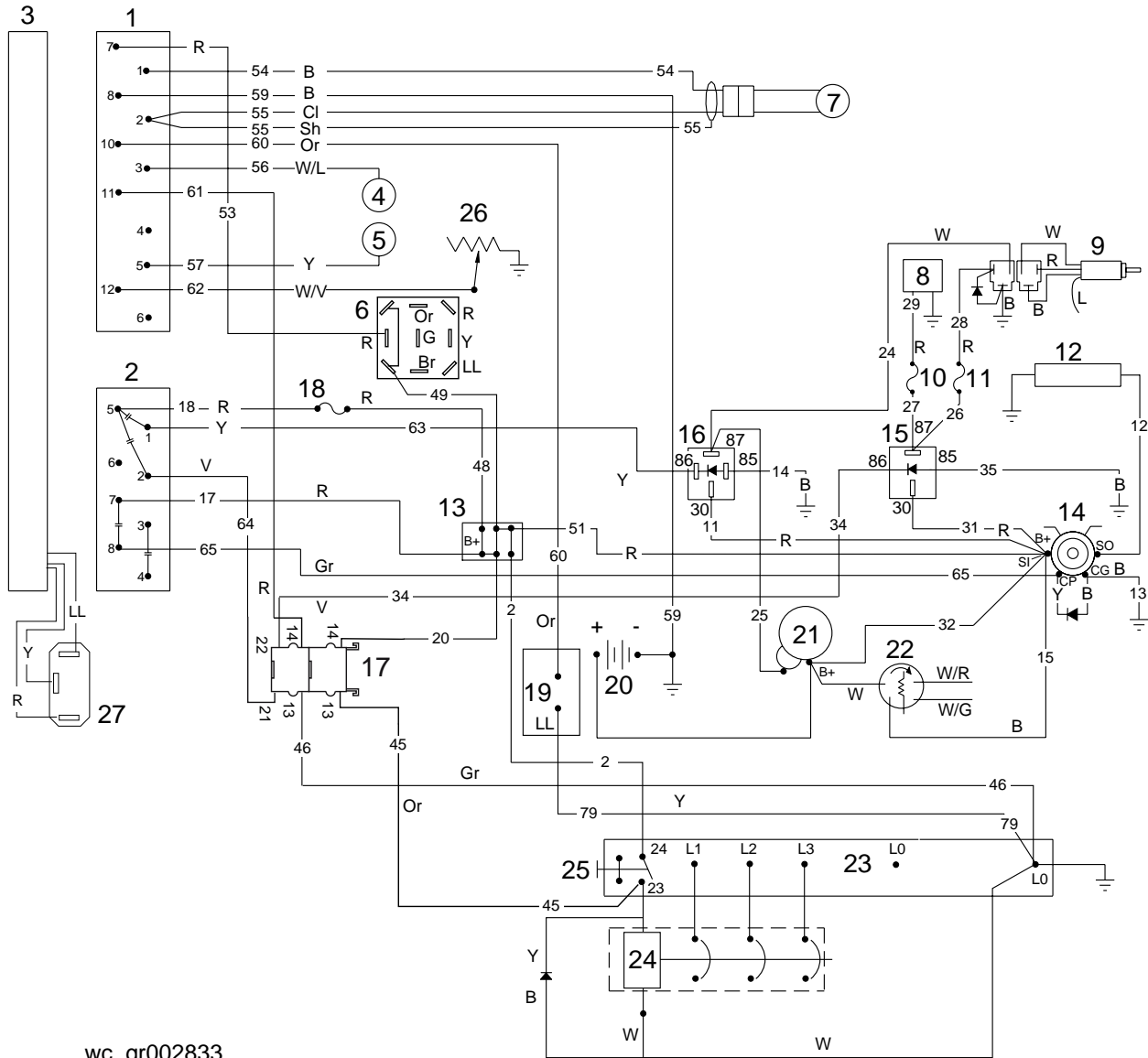

Wire Colors							
B	Black	R	Red	Y	Yellow	Or	Orange
G	Green	T	Tan	Br	Brown	Pr	Purple
L	Blue	V	Violet	Cl	Clear	Sh	Shield
P	Pink	W	White	Gr	Gray	LL	Light blue

6.3 Engine Wiring Components—Isuzu

Ref.	Component	Ref.	Component
1	Plug 1 — engine sender inputs	15	Fuel relay
2	Plug 2 — engine start outputs	16	Starter relay
3	Engine Control Module (ECM)	17	Emergency stop switch
4	Oil pressure sender	18	10A fuse #1
5	Water temperature sender	19	Remote start terminals
6	Remote Start - Off - Start/Run switch	20	Battery
7	Magnetic pickup	21	Starter motor
8	Fuel pump	22	Alternator
9	Fuel solenoid	23	Mechanical lugs
10	10A fuse #2	24	Main circuit breaker — shunt trip
11	25A fuse	25	Lug door interlock switch
12	Glow plugs	26	Fuel level sender
13	B+ terminal block	27	Hour meter switch
14	Glow plug relay	-	---

ECM Plug 1 Wires			ECM Plug 2 Wires		
Pin	Wire	Description	Pin	Wire	Description
7	R/53	Run/Off/Auto switch +12V	5	R/18	In; 12VDC from 10A fuse
1	B/54	Magnetic pickup ground	1	Y/63	Out; 12VDC to start relay
8	B/59	Battery (negative)	2	V/64	Out; 12VDC to E-stop
2	Cl,Sh/55	Magnetic pickup	7	R/17	In; 12VDC from B+
10	Or/60	Remote start	8	Gr/65	Out; 12VDC to glow plug relay
3	W/L/56	Oil pressure sender	-	-	---
11	R/61	Emergency stop	-	-	---
5	Y/57	Water temperature sender	-	-	---
12	W/V/62	Fuel level sender	-	-	---

6.4 Engine Electrical Component Locations—Isuzu

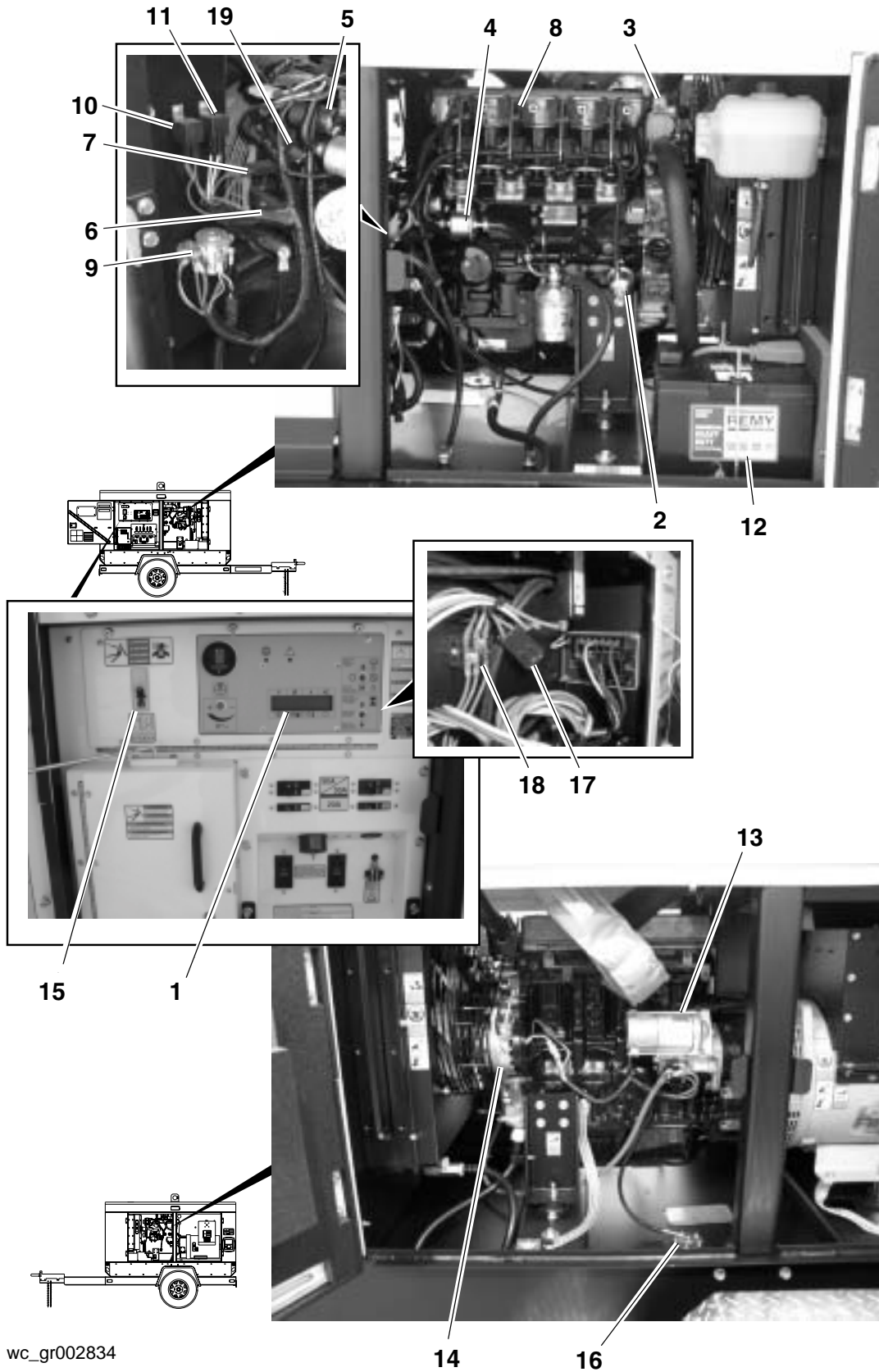

wc\_gr002834

## 6.5 Engine Electrical Components—*Isuzu*

See Graphic: *wc\_gr002834*

Ref.	Component	Ref.	Component
1	Engine Control Module (ECM)	11	Starter relay
2	Oil pressure sender	12	Battery
3	Water temperature sender	13	Starter motor
4	Fuel pump	14	Alternator
5	Fuel solenoid	15	Main circuit breaker
6	10A fuse #2	16	Fuel level sender
7	25A fuse	17	10A fuse #1
8	Glow plugs	18	B+ terminal block
9	Glow plug relay	19	Magnetic pickup
10	Fuel relay	-	---

## 6.6 Troubleshooting Flowcharts

The troubleshooting flowcharts are designed to take you through the process of determining the source of a problem with engine starting or machine operation. Many of the tests involve live voltages and therefore should only be attempted by qualified personnel. Detailed procedures for carrying out the tests are included in this manual. All highlighted text within the flowcharts have matching sections in this manual.

6.7 Engine Troubleshooting—Isuzu

Engine Troubleshooting  
Flowchart 1A  
Isuzu

\* Battery voltage approximately 12V

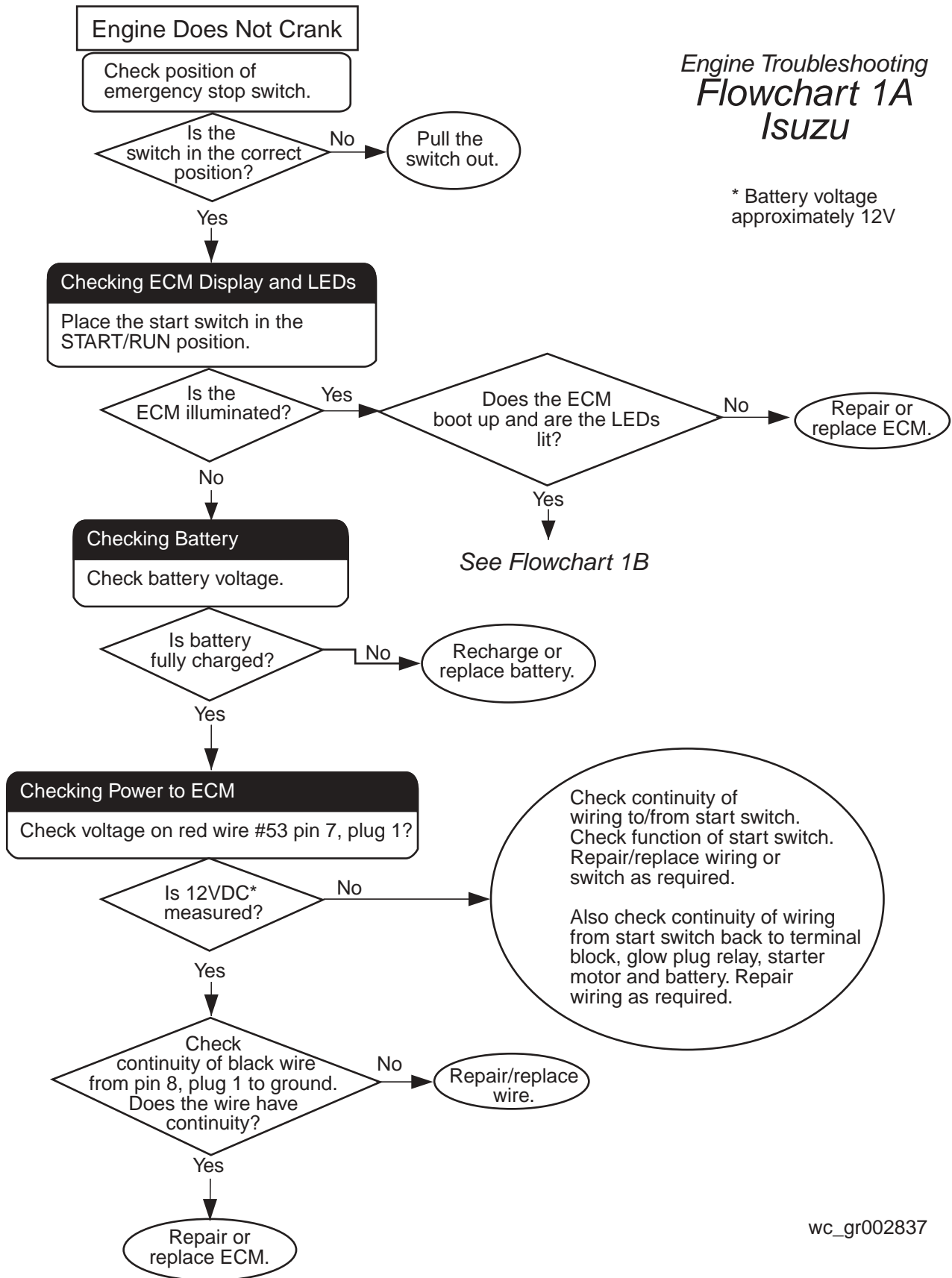

wc\_gr002837

Engine Troubleshooting  
**Flowchart 1B**  
**Isuzu**

\* Battery voltage approximately 12V

Engine does not Crank  
 Continued from Flowchart 1A

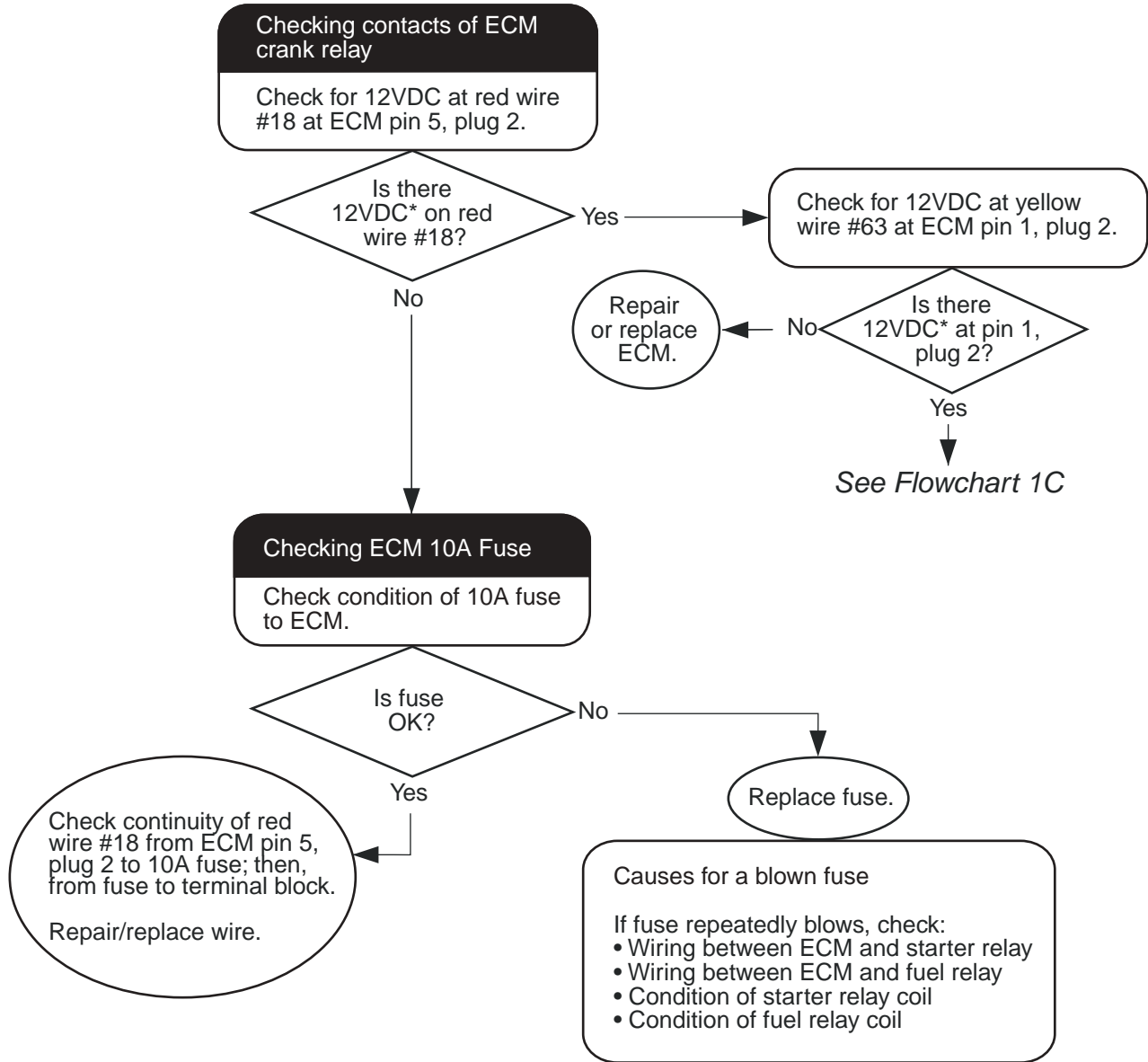

wc\_gr002847

Engine does not crank  
Continued from Flowchart 1B

Engine Troubleshooting  
**Flowchart 1C**  
Isuzu

\* Battery voltage  
approximately 12V

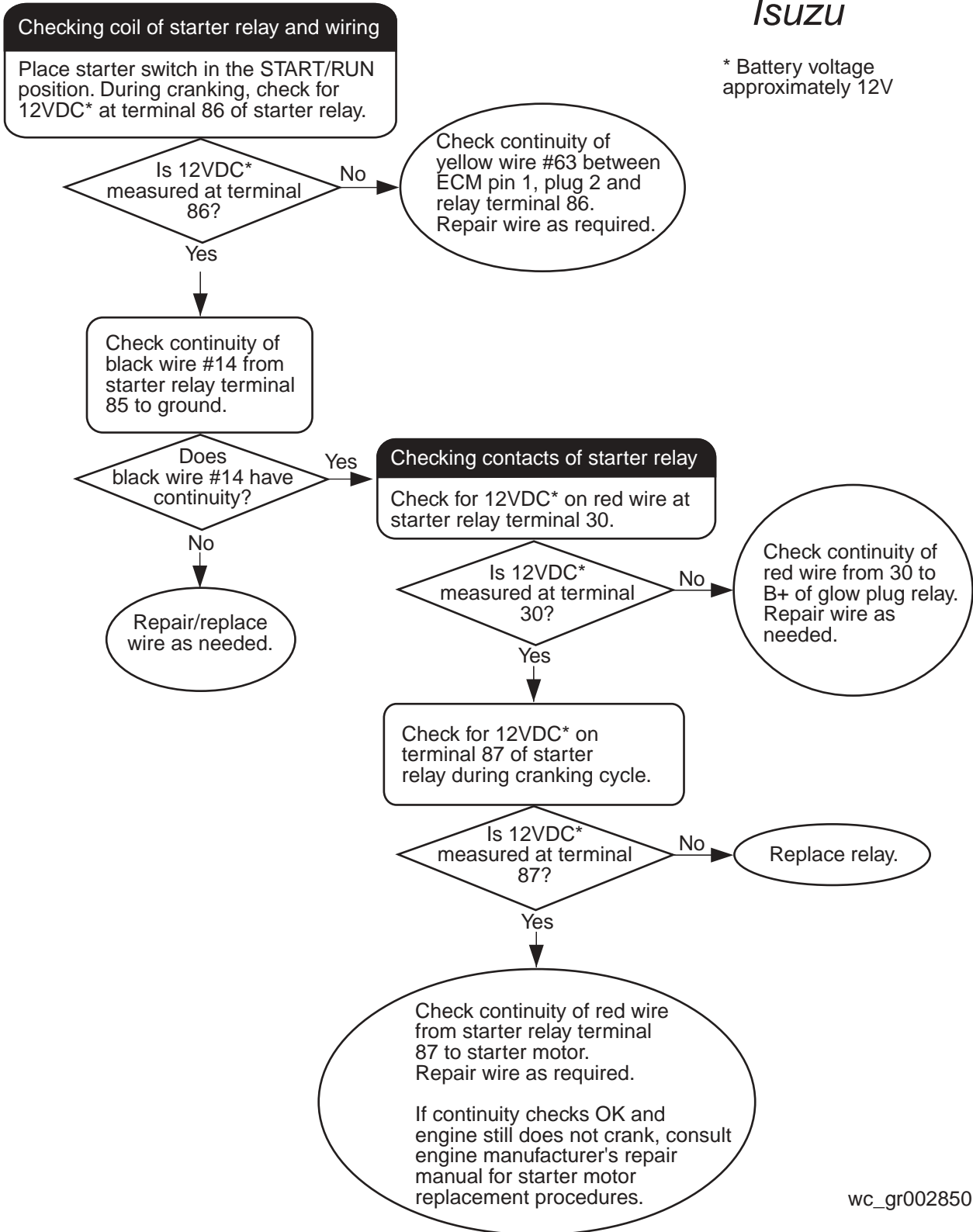

## 6.8 Checking Wire Continuity

When checking the continuity of a wire, use the Ohms scale on your checking instrument (multimeter). A reading of less than one Ohm means the wire has continuity and should be OK. A reading over one Ohm usually means that the wire or connectors are corroded and should be repaired or replaced. A reading of "OL" or "OPEN" means the wire is broken and there is no continuity. In such cases, repair or replace the wire.

## 6.9 Probing Plugs and Pins

See Graphic: *wc\_gr002926*

To measure the voltage at an ECM pin, attach an appropriate extension **(a)** to the positive probe on your multimeter. Slide the positive probe into the plug along the wire of the pin to be tested. Use care when testing this way so you don't damage the wire, plug, or ECM. Find a suitable ground on the machine's frame for the negative probe **(b)** of your multimeter.

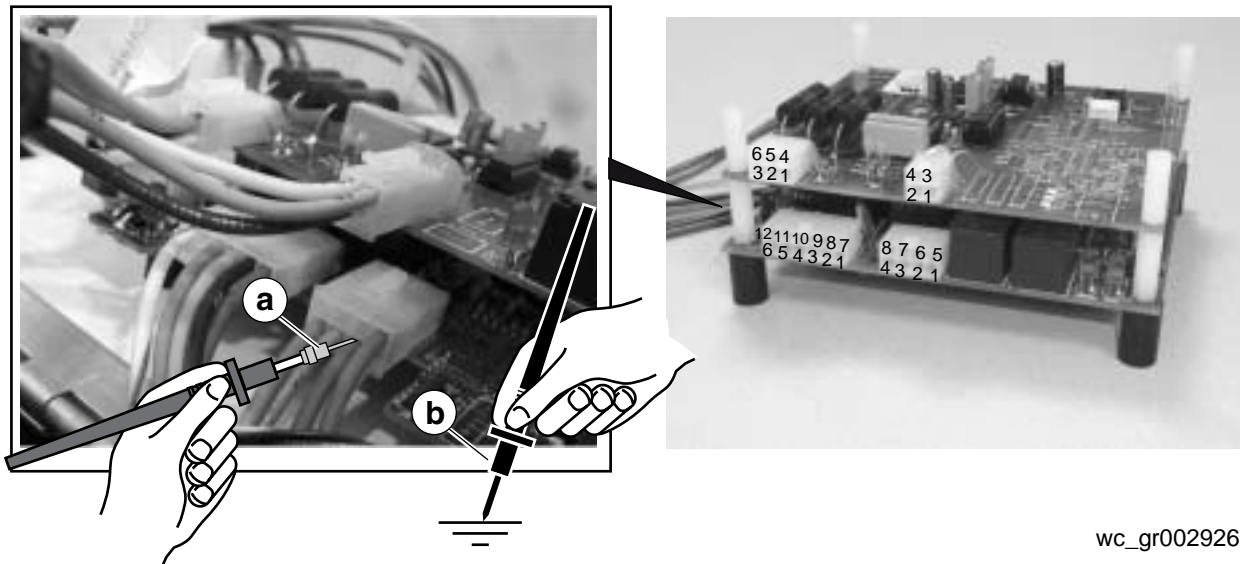

wc\_gr002926

## 6.10 Checking ECM Display and LEDs

See Graphic: *wc\_gr002835*

After placing the start switch in the START/RUN position, the ECM goes through a boot-up sequence. On early machines the ECM displays “Preheating”, then “Cranking”. Later model machines display “Initializing...”, “Time to Service”, and then “Cranking \_ of 3”. During the preheat cycle (heater activation), the LED **(b)** near the stop sign illuminates.

To check the general condition of the ECM, carry out the following procedures:

- 6.10.1 Remove the three screws **(a)** securing the control panel and open the panel.
- 6.10.2 Check the condition of all ECM connectors (plugs) and wiring. Make sure wires are secure in the plugs and that the plugs are connected securely to the ECM. Also look for burn marks, melting, and signs of damage; repair or replace wiring/plugs as needed.
- 6.10.3 Place the start switch in the START/RUN position.
  - If the ECM display does not illuminate, check the battery. See section *Checking Battery*.
  - If the ECM display does illuminate, continue.
- 6.10.4 Place the start switch in the START/RUN position and check that the ECM display illuminates and that the boot-up sequence has started.
  - If the ECM does not go through the boot-up sequence, the ECM may be malfunctioning. Repair or replace the ECM. Call Wacker Service.
  - If the ECM goes through the boot-up sequence, continue.
- 6.10.5 Locate the two red LEDs **(c)** on the left side of the lower ECM circuit board. Place the start switch in the OFF position then in the START/RUN position. Check that the “FUEL” LED illuminates after the preheat period has ended and stays lit for the entire cranking period. Also check that the “CRANK” LED illuminates when the engine is attempting to crank.
  - If the LEDs do not illuminate as described above, the ECM may be malfunctioning. Repair or replace the ECM. Call Wacker Service.

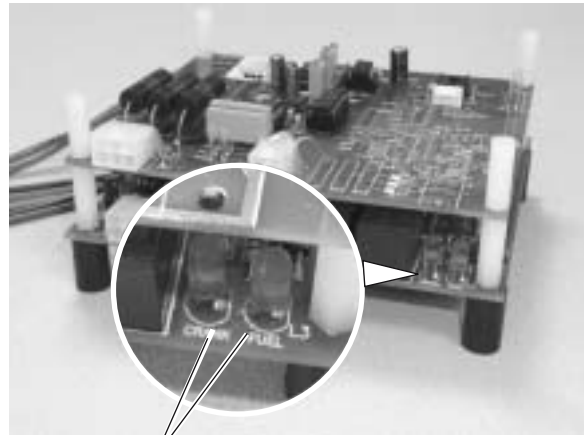
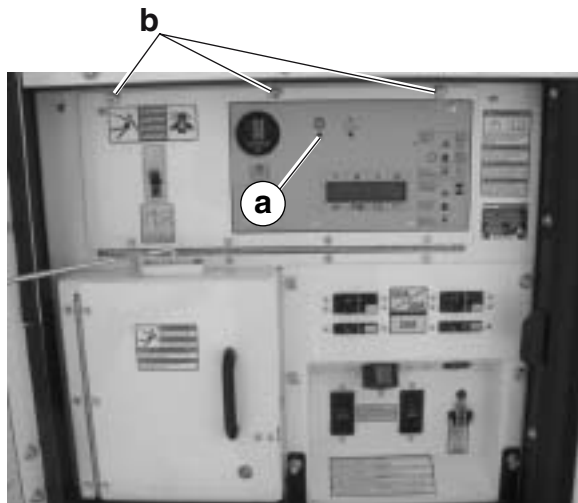

wc\_gr002835

## 6.11 Checking Battery

The ECM display may or may not be blank when battery voltage is less than 12V. During such a condition, the battery may be charged enough to light the display, but not enough to fully crank the starter.

- 6.11.1 Check that battery cable connections are tight.
- 6.11.2 Check battery terminals for corrosion. Clean the terminals if necessary. Corroded terminals and loose connections will result in hard starting and insufficient battery charge.
- 6.11.3 Check battery for proper voltage: 11–13V.
- 6.11.4 Charge or replace the battery if needed.

**CAUTION:** Do not jump start the machine using a battery with greater than 12–14V. Damage to the machine's electrical system will occur.

## 6.12 Checking Power to ECM

See Graphic: *wc\_gr002833* and *wc\_gr002836*

- 6.12.1 Place the start switch (6) in the START/RUN position and check for 12VDC (battery voltage approximately 12V) between red wire #53 at ECM pin 7, plug 1 and ground.
- If 12VDC is measured, the ECM is receiving power. Go to step 8.
  - If 12VDC is not measured, continue.
- 6.12.2 Place the start switch in the OFF position and check the continuity of red wire #53 from pin 7, plug 1 to the start switch.
- If the wire does not have continuity, repair or replace it.
  - If the wire has continuity, continue.
- 6.12.3 Check the start switch. Remove the red wires **(a)** and check the terminals for continuity—outer terminals to center (only one pair of terminals per switch position).
- If the switch does not have continuity, repair or replace it.
  - If the switch has continuity, continue.
- 6.12.4 Check the continuity of red wire #49 between the start switch and the terminal block (13) **(b)**.
- If the wire does not have continuity, repair or replace it.
  - If the wire has continuity, continue.
- 6.12.5 Check the continuity of red wire #51 between the terminal block and the glow plug relay (14) **(c)**.
- If the wire does not have continuity, repair or replace it.
  - If the wire has continuity, continue.
- 6.12.6 Check the continuity of the red wire #32 **(d)** between the glow plug relay and the starter motor (21).
- If the wire does not have continuity, repair or replace it.
  - If the wire has continuity, continue.
- 6.12.7 Check the continuity of the red wire **(e)** between the starter motor and the battery (20).
- If the wire does not have continuity, repair or replace it.
  - If the wire has continuity, continue.
- 6.12.8 Check the continuity of the black wire #59 from pin 8, plug 1 to ground.
- If the wire does not have continuity, repair or replace it.
  - If the wire has continuity and the ECM is receiving power, the ECM should be functioning. If it is not, repair or replace it. Call Wacker Service.

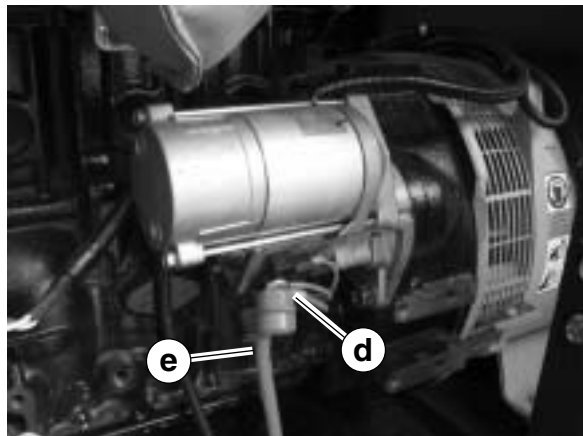
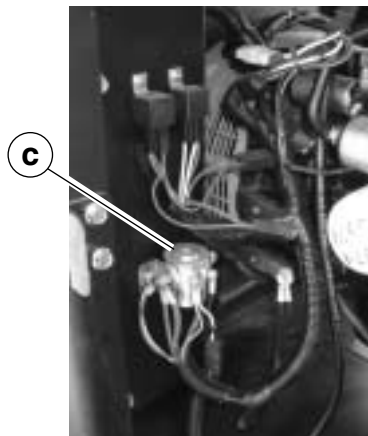
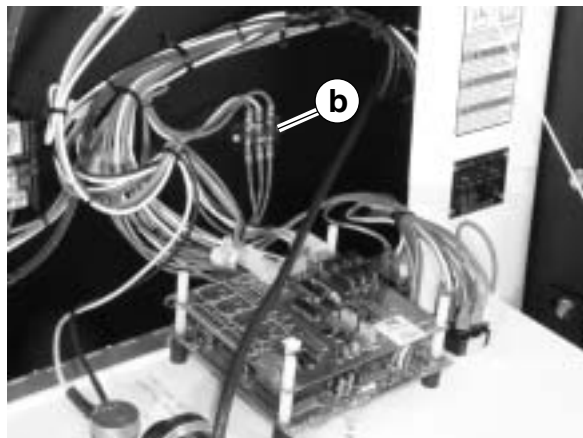
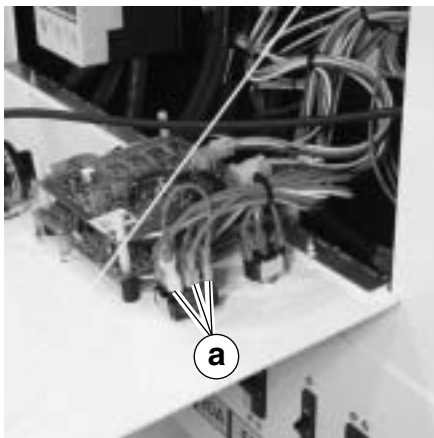
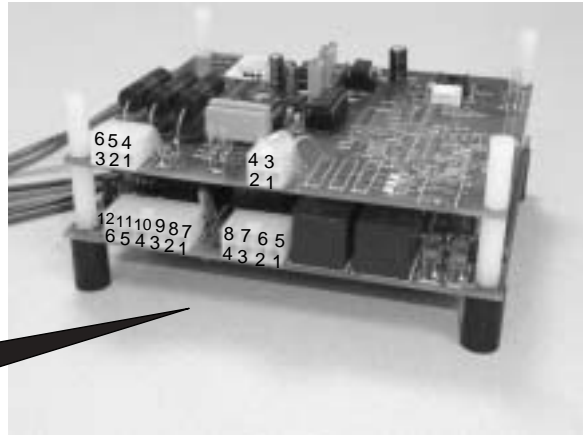
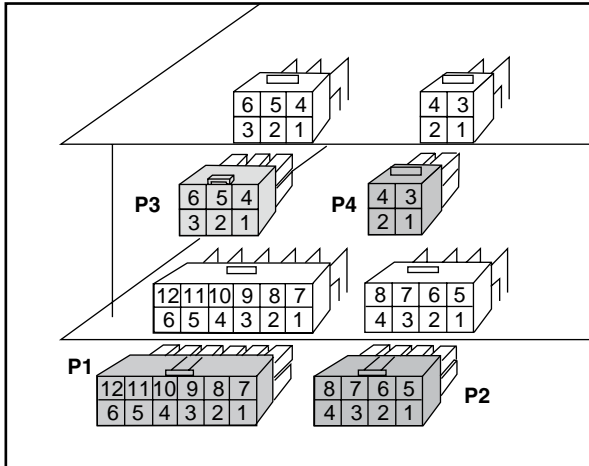

wc\_gr002836

### 6.13 Checking Contacts of ECM Crank Relay

See Graphic: *wc\_gr002833* and *wc\_gr002829*

When the start switch is placed in the START/RUN position, the ECM crank relay **(c)** energizes. The ECM crank relay supplies 12VDC through yellow wire #63 to energize the starter relay (14).

- 6.13.1 Check for 12VDC (battery voltage approximately 12V) between red wire #18 at pin 5, plug 2 and ground.
- If 12VDC is measured, the ECM relay contact circuit is receiving power. Go to step 5.
  - If 12VDC is not measured, continue.
- 6.13.2 Check the ECM 10A fuse (18)**(a)**.
- If the fuse is blown, see section *Checking ECM 10A Fuse*.
  - If the fuse is OK, continue.
- 6.13.3 Check continuity of red wire #18 from ECM pin 5, plug 2 to the 10A fuse.
- If the wire does not have continuity, repair or replace it.
  - If the wire has continuity, continue.
- 6.13.4 Check the continuity of red wire #48 from the 10A fuse to the B+ terminal strip **(b)**.
- If the wire does not have continuity, repair or replace it.
  - If the wire has continuity, continue.
- 6.13.5 Place the start switch in the START/RUN position and probe yellow wire #63 at pin 1, plug 2 for 12VDC during the cranking cycle.
- If 12VDC is measured, the ECM crank relay contact circuit is functioning.
  - If 12VDC is not measured, the ECM is malfunctioning; repair or replace it. Call Wacker Service.

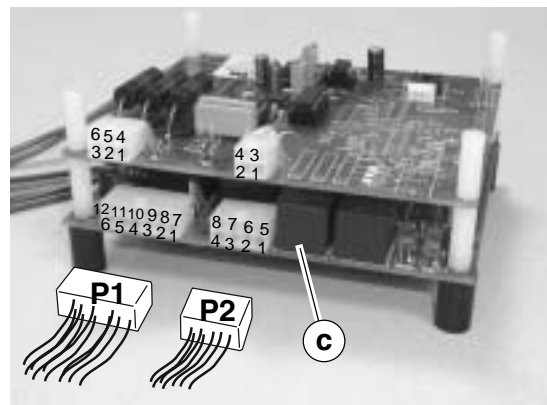
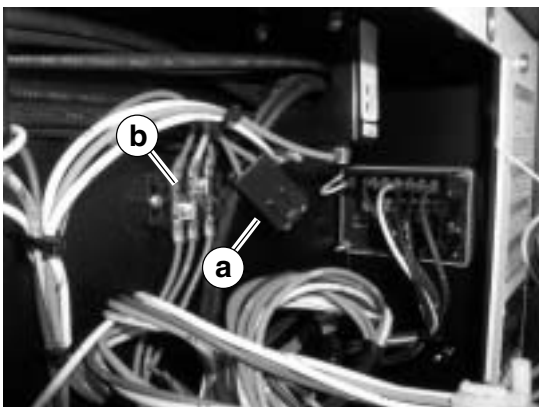

wc\_gr002829

## 6.14 Checking ECM 10A Fuse

See Graphic: *wc\_gr001987*

The 10A fuse is found in the control compartment on G25 models **(a)**. It is found in the engine compartment on all other models **(b)**. There is 12VDC fed through this fuse to the ECM fuel and crank relay contacts via ECM pin 5, plug 2. If the fuse repeatedly blows, it is a sign that there is a short in the wires to/from the ECM, a diode is faulty, or the fuel or starter relay is shorted.

6.14.1 Check the 10A fuse. If it is blown, check:

- The condition of the wiring to/from the fuse. Repair or replace the wiring as needed.
- On Isuzu-powered generators, check the condition of the starter relay coil (see section *Checking Coil of Starter Relay and Wiring*); condition of the fuel relay coil (see section *Checking Coil of Fuel Pump Relay*). Also check for failed diodes. See section *Checking Diode Across Relay/Solenoid Coil*.
- On Deere-powered generators, check the condition of the starter relay coil (see section *Checking Coil of Starter Relay and Wiring*); and the condition of the fuel solenoid (see section *Checking Fuel Solenoid*). Also check for failed diodes. See section *Checking Diode Across Relay/Solenoid Coil*.

6.14.2 Once the wiring, relay/solenoid coils, and diodes check OK, replace the 10A fuse.

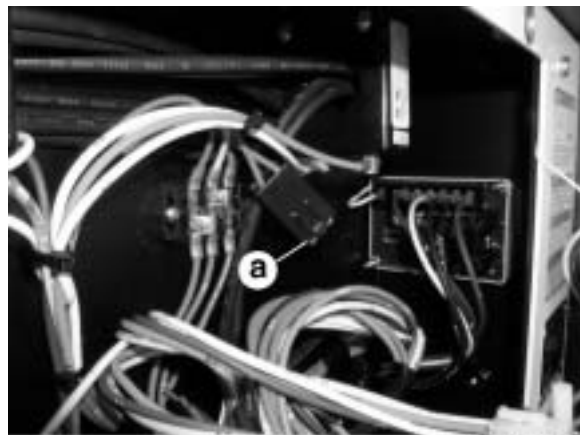

*wc\_gr001987*

## 6.15 Checking Coil of Starter Relay and Wiring

See Graphic: *wc\_gr002833 and wc\_gr002848*

- 6.15.1 Place the start switch in the START/RUN position. During the cranking cycle, check for 12VDC (battery voltage approximately 12V) between yellow wire #63 at terminal 86 of the starter relay **(a)** (16) and ground.
- If 12VDC is measured, the starter relay is receiving power.
  - If 12VDC is not measured, continue.
- 6.15.2 Check the continuity of yellow wire #63 from ECM pin 1, plug 2 to terminal 86 of starter relay.
- If the wire does not have continuity, repair or replace it.
  - If the wire has continuity, continue.
- 6.15.3 If 12VDC is measured at terminal 86, continue checking the coil by checking the continuity of black wire #14 between starter relay terminal 85 and ground. Repair the wire as needed.

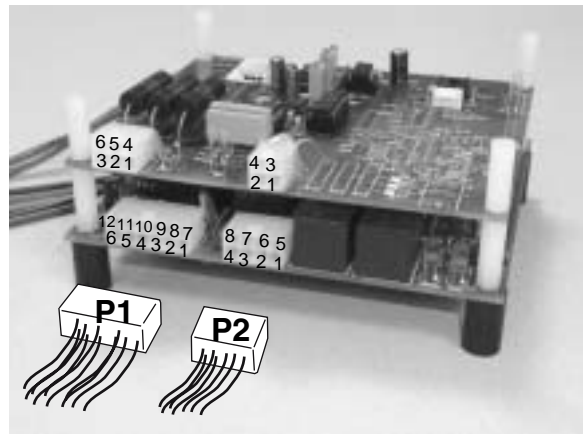
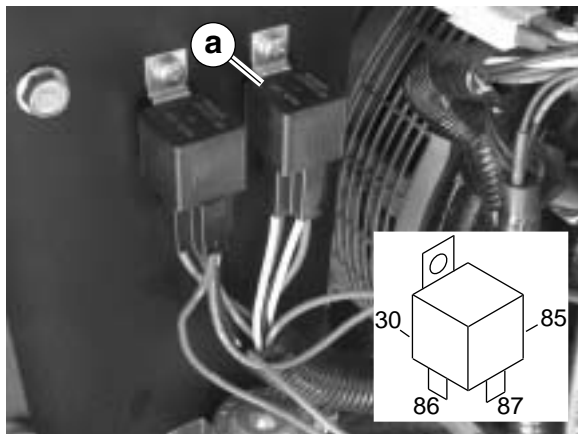

wc\_gr002848

## 6.16 Checking Diode Across Relay/Solenoid Coil

See Graphic: wc\_gr002803

The glow plug relay (a) and the fuel solenoid (b) on Isuzu powered generators, and the starter relay (c) (and fuel solenoid (d) on John Deere engines without the Engine Control Unit (ECU)), all have a diode (e) similar to the one pictured connected across the coil. The diodes are encapsulated in rubber. They are installed in the circuit to redirect a voltage spike to ground if one should occur during powering down the relay's coil. In order to check the diode, separate the diode portion from the connector portion.

**Note:** Replacement diodes come with the connector portion and wiring. It is permissible to remove and discard the replacement connector portion and insert the replacement diode into the existing connector and wiring.

- 6.16.1 Using the diode scale on a multimeter, check that the diode conducts in only one direction and not in the other. The meter should read 0.450–0.550V in one direction and “OL” or “OPEN” in the other. Replace the diode if necessary.
- 6.16.2 On “can style” relays (the glow plug relay on G 25, the starter relay on all other generators), check that the yellow wire of the diode is attached to the power terminal of the relay's coil (labeled “CP” on the schematic) and that the black wire is attached to the ground terminal of the relay's coil (labeled “CG” on the schematic). Correct the wiring as needed.

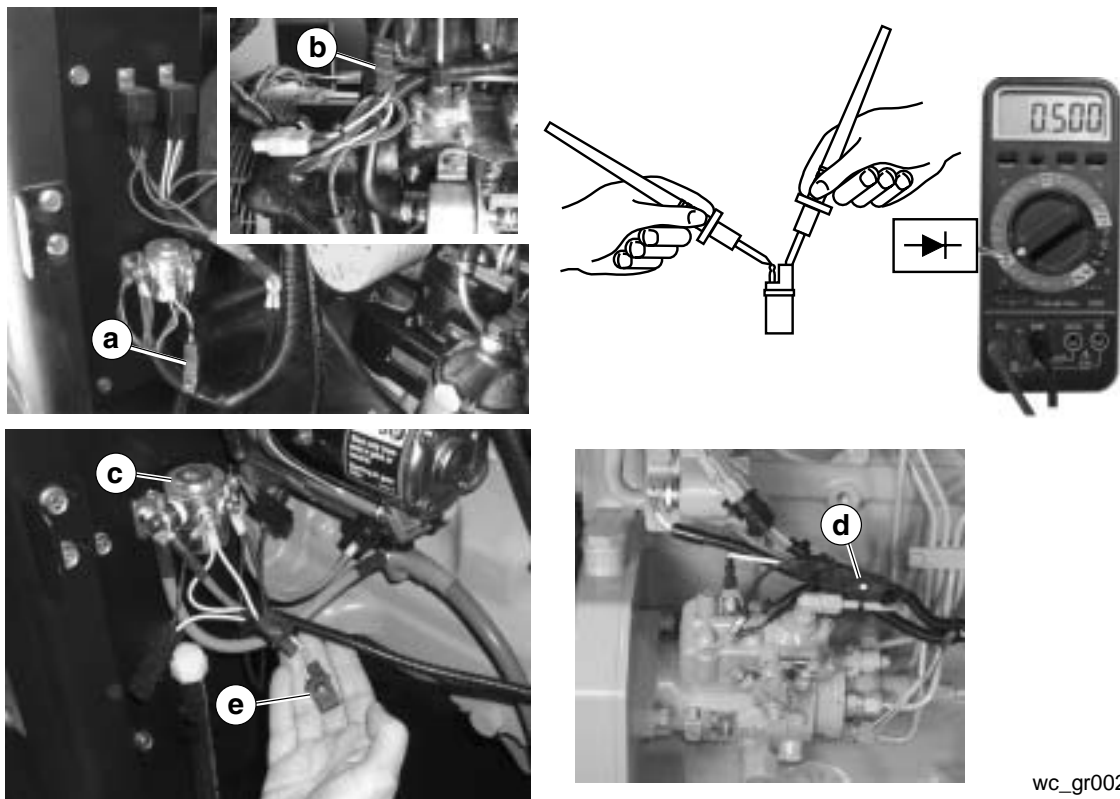

wc\_gr002803

## 6.17 Checking Contacts of Starter Relay

See Graphic: wc\_gr002922

The starter relay coil and its wiring must be functioning properly before checking the starter relay contacts. See section *Checking Coil of Starter Relay and Wiring*.

- 6.17.1 Check for 12VDC (battery voltage approximately 12V) between the red wire at terminal 30 of the starter relay **(a)** and ground.
- If 12VDC is not measured, check the continuity of red wire #11 from terminal B+ of the glow plug relay to terminal 30 of the starter relay. If necessary, check the continuity of red wire #32 from terminal B+ of the glow plug relay to B+ terminal of starter motor, then back to battery. Repair wiring as needed.
  - If 12VDC is measured at terminal 30, continue.
- 6.17.2 Place the start switch in the START/RUN position and during the cranking cycle, check for 12VDC between terminal 87 of the starter relay and ground.
- If 12VDC is not measured at terminal 87 of the starter relay during the cranking cycle, replace the starter relay.
  - If 12VDC is measured at terminal 87 of the starter relay during the cranking cycle, the starter relay is functioning.
- 6.17.3 Place the start switch in the START/RUN position and during the cranking cycle check for 12VDC between red wire #25 at the starter motor solenoid and ground.
- If 12VDC is not measured, check the continuity of red wire #25. Repair or replace the wire as needed.
  - If 12VDC is measured, and the engine still does not crank, check the engine manufacturer's service manual for starter motor replacement procedures.

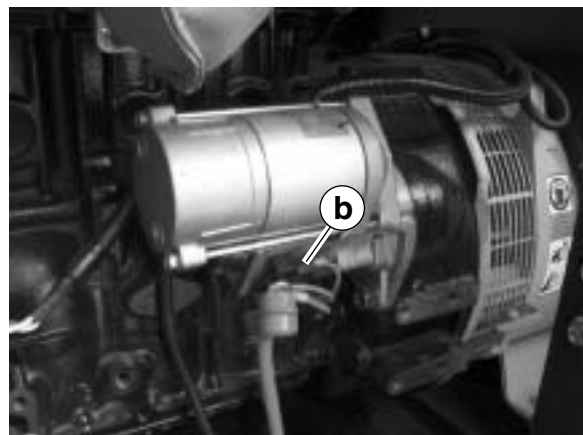
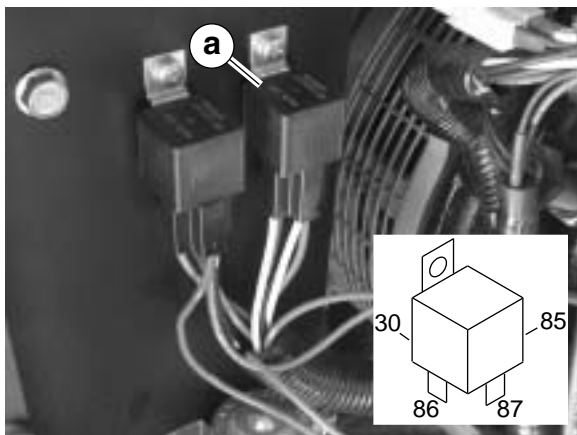

wc\_gr002922

6.18 Engine Cranks But Does Not Start—Isuzu

Engine Troubleshooting  
Flowchart 1D  
Isuzu

\* Battery voltage approximately 12V

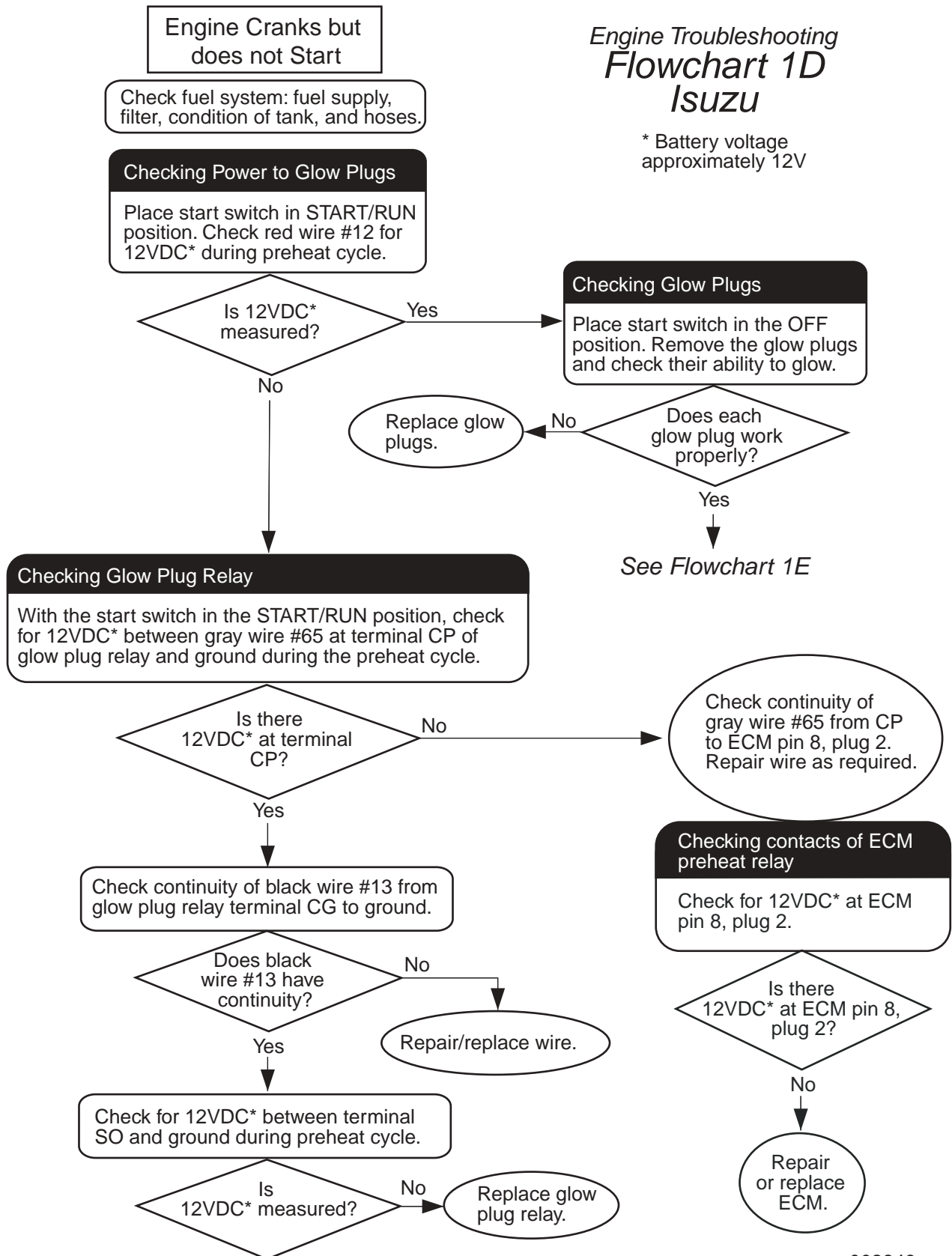

wc\_gr002849

Engine Cranks but does not Start  
Continued from Flowchart 1D

Engine Troubleshooting  
**Flowchart 1E**  
**Isuzu**

\* Battery voltage approximately 12V

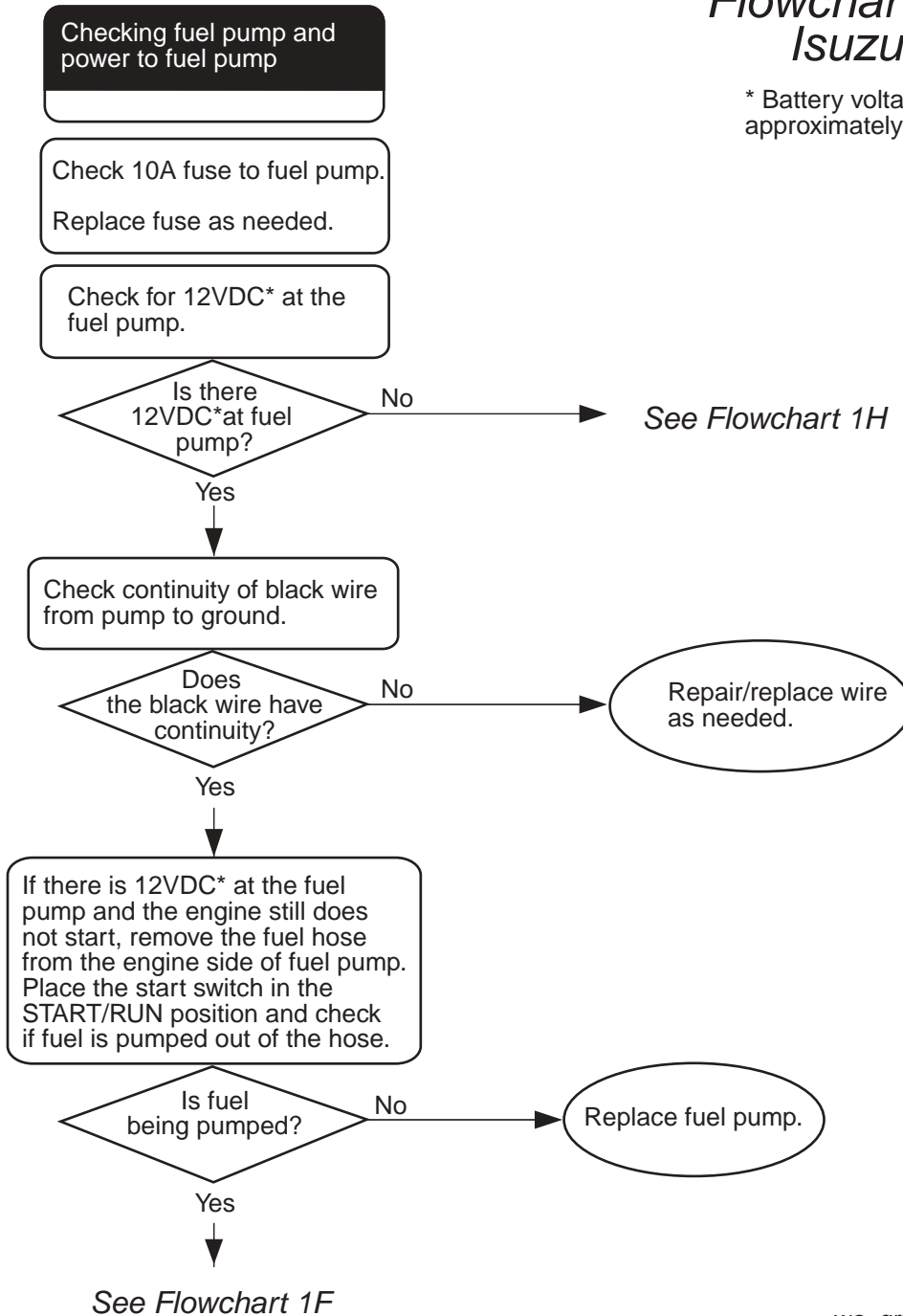

wc\_gr002923

Engine Cranks but does not Start  
Continued from Flowchart 1E

Engine Troubleshooting  
**Flowchart 1F**  
Isuzu

\* Battery voltage approximately 12V

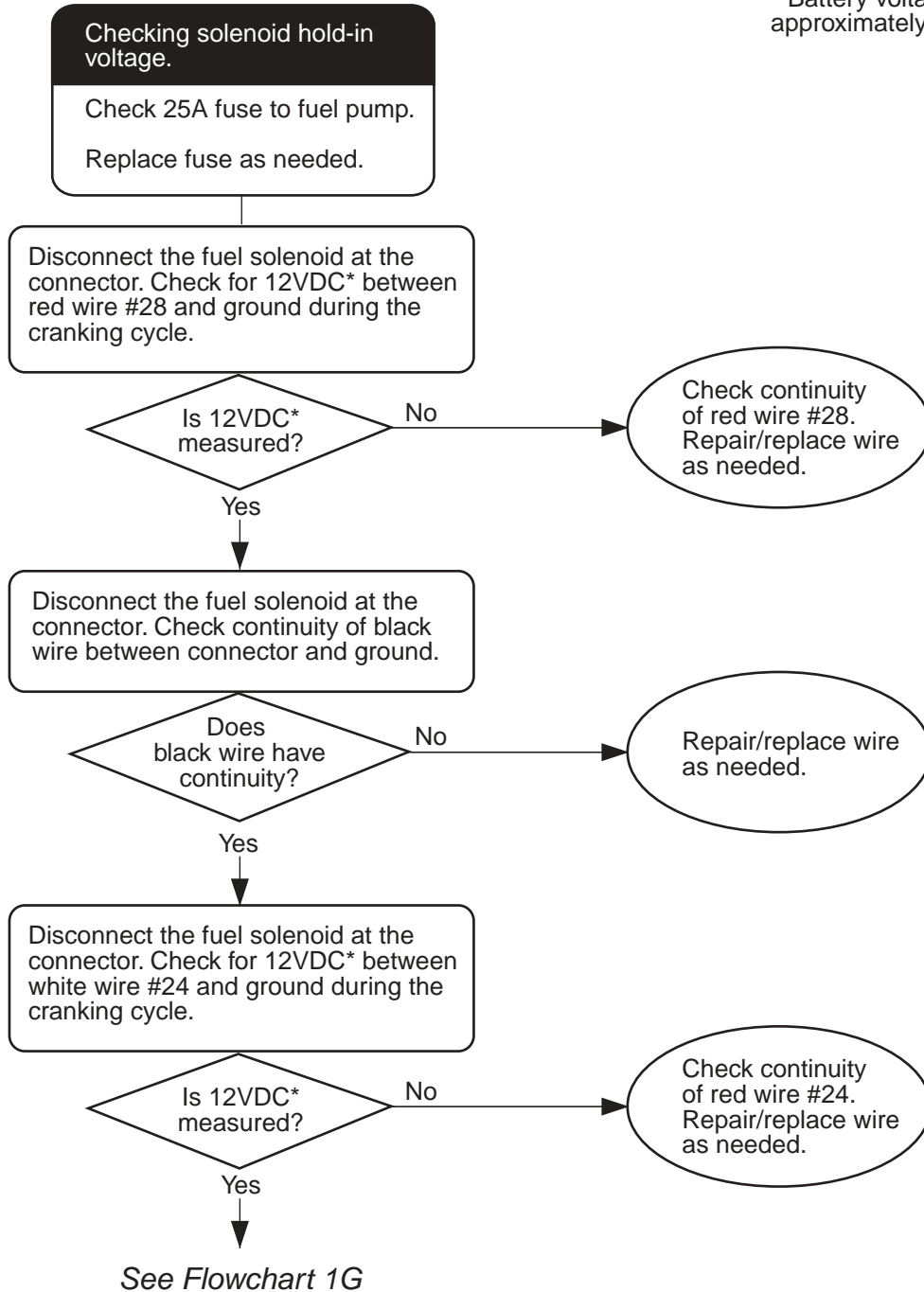

wc\_gr002840

Engine Cranks but does not Start  
Continued from Flowchart 1F

Engine Troubleshooting  
Flowchart 1G  
Isuzu

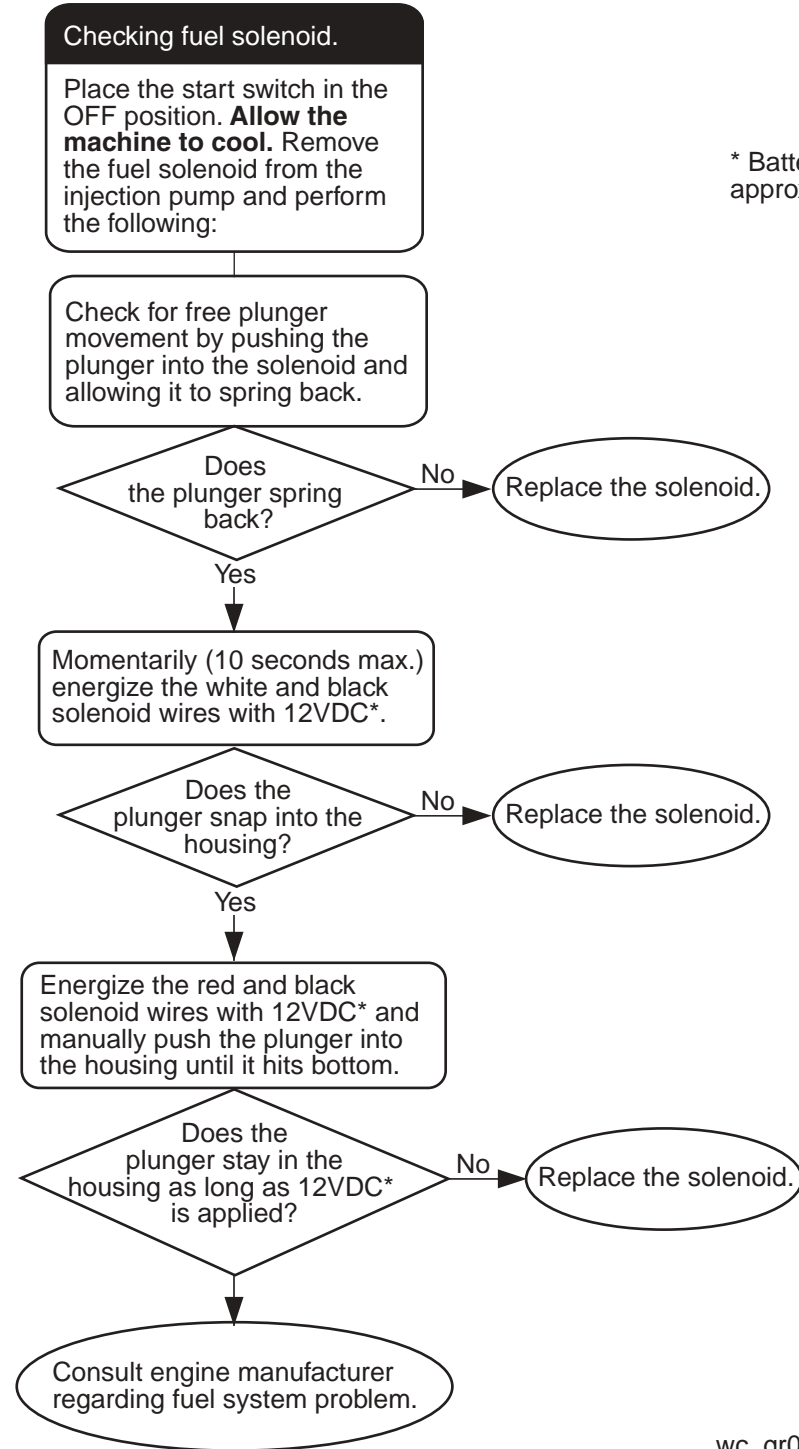

\* Battery voltage approximately 12V

wc\_gr002853

Engine Troubleshooting  
Flowchart 1H  
ISUZU

\* Battery voltage approximately 12V

Engine Cranks but does not Start  
Continued from Flowchart 1E

Checking coil of fuel pump relay

Check for 12VDC\* during cranking period on violet wire #34 at terminal 86 of the fuel pump relay.

Is 12VDC\* measured?

Yes

Check continuity of black wire #35 from terminal 85 of fuel pump relay to ground.

Does black wire #35 have continuity?

No

Repair/replace wire.

Check continuity of red wire #27 from terminal 87 to the 10A fuse.  
Repair/replace wire as needed.

No

Check continuity of violet wires #64 and #34 from ECM pin 2, plug 2 through emergency stop switch to terminal 86 of fuel pump relay. Repair/replace wire or emergency stop switch as needed.

Checking contacts of ECM fuel relay

Check for 12VDC\* at pin 2, plug 2 during the cranking cycle.

Is 12VDC\* measured at pin 2, plug 2?

Yes

Call Wacker Service.

Replace ECM.

Yes

Checking contacts of fuel pump relay

Check power to be switched.

Is there 12VDC\* on red wire #31 to terminal 30?

Yes

Place start switch in START/RUN position and check for 12VDC\* on terminal 87 of fuel pump relay during cranking.

Is there 12VDC\* on terminal 87?

Yes

No

Replace fuel pump relay.

No

Check continuity of red wire #31 from terminal 30 to B+ terminal of glow plug relay. Repair wire as needed.

wc\_gr002851

6.19 Checking Power to Glow Plugs

See Graphic: *wc\_gr002833* and *wc\_gr002841*

- 6.19.1 Place the start switch in the START/RUN position. Check for 12VDC between red wire #12 (a) at the glow plug(s) (b) and ground during the preheat cycle.
  - If 12VDC is measured, the glow plugs are receiving power; go to step 3.
  - If 12VDC is not measured, continue.
- 6.19.2 Place the start switch in the OFF position. Check the continuity of red wire #12 from terminal SO of the glow plug relay 14 to the glow plugs.
  - If the wire does not have continuity, repair or replace it.
  - If the wire has continuity, see section *Checking Glow Plug Relay and Wiring*.
- 6.19.3 Remove the glow plugs and check their ability to glow. See section *Checking Glow Plugs*.

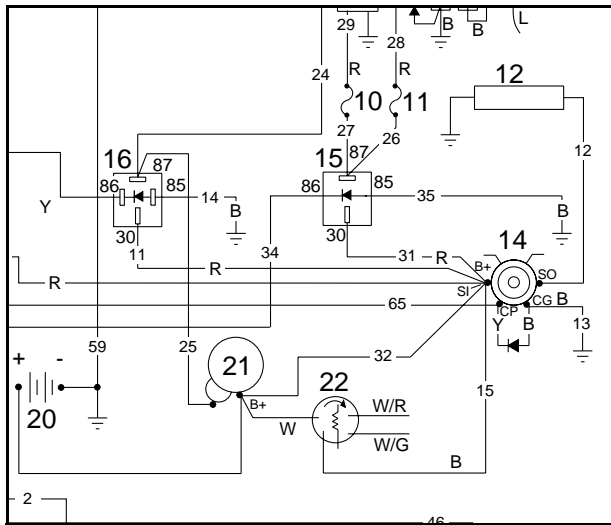

Schematic *wc\_gr002833* detail

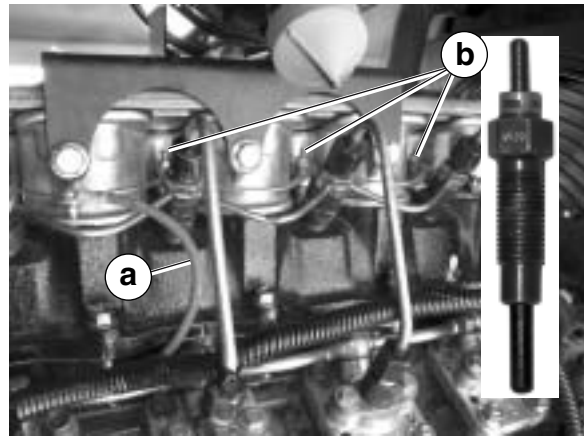

*wc\_gr002841*

## 6.20 Checking Glow Plugs

See Graphic: *wc\_gr002033*

- 6.20.1 Remove the glow plug from the engine.



Burn hazard. Glow plugs can reach temperatures up to 1200°F (649°C). Do not touch the element of the glow plug. Be extremely careful when testing the glow plug.

- 6.20.2 Using 10-gauge wire, apply 12VDC to the glow plug—positive on the upper portion and ground the base. If the glow plug does not heat (glow) within five seconds, replace the glow plug.

**Note:** *If any one of the glow plugs needs replacing, replace all of them.*



*wc\_gr002033*

## 6.21 Checking Glow Plug Relay and Wiring

See Graphic: *wc\_gr002833 and wc\_gr002838*

The glow plug relay (**a**) is the chrome “can-style” relay located inside the engine compartment.

- 6.21.1 Check power to the coil of the relay by measuring voltage (battery voltage approximately 12V) between terminal CP and ground during the preheat cycle.
- If 12VDC is not measured, check the continuity of gray wire #65 between terminal CP and ECM pin 8, plug 2. Repair/replace wire as necessary. Also check condition of the ECM on-board preheat relay. See section *Checking Contacts of ECM Preheat Relay*.
  - If 12VDC is measured, the coil of the relay is receiving power; continue.
- 6.21.2 Check the ground wire of the relay coil by checking continuity of black wire #13 from terminal CG to ground. Repair/replace the wire as necessary.
- 6.21.3 Check the power to be switched by measuring voltage between terminal SI and ground.
- If 12VDC is not measured, check continuity of red wire #32 from terminal SI to B+ terminal of the starter motor. Repair or replace the wire as needed.
  - If 12VDC is measured, continue.
- 6.21.4 Check the operation of the contacts inside the relay by measuring the voltage between terminal SO and ground during the preheat cycle.
- If 12VDC is not measured, replace the preheat relay.
  - If 12VDC is measured, the glow plug relay is functioning.

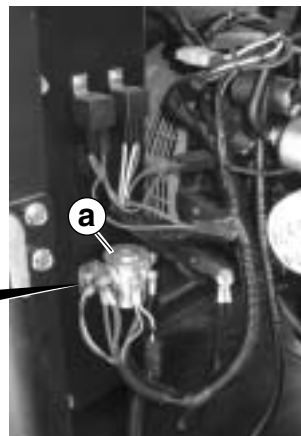
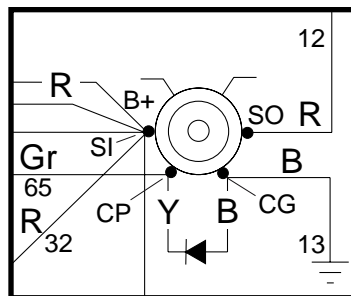

wc\_gr002838

6.22 Checking Contacts of ECM Preheat Relay

See Graphic: *wc\_gr002833* and *wc\_gr002936*

The ECM includes an onboard preheat relay **(a)** which is located on on the lower board, behind the crank and fuel relays. To test the function of its contacts carry out the following procedure:

- 6.22.1 Probe ECM pin 7, plug 2 **(b)** at red wire #17 for 12VDC (battery voltage approximately 12V). Measure between red wire #17 to pin 7, plug 2 and ground.
  - If 12VDC is not measured, check the continuity of red wire #17 from pin 7, plug 2 to the B+ terminal strip. Repair or replace the wire as required.
  - If 12VDC is measured, continue.
- 6.22.2 Place the start switch in the START/RUN position and probe ECM pin 8, plug 2 at gray wire #65 for 12VDC. Measure between gray wire #65 and ground during the preheat cycle.
  - If 12VDC is measured, continue by checking the slave preheat relay. See section *Checking Slave Preheat Relay and Wiring*.
  - If 12VDC is not measured, the ECM may be malfunctioning. Call Wacker Service. Repair or replace the ECM.

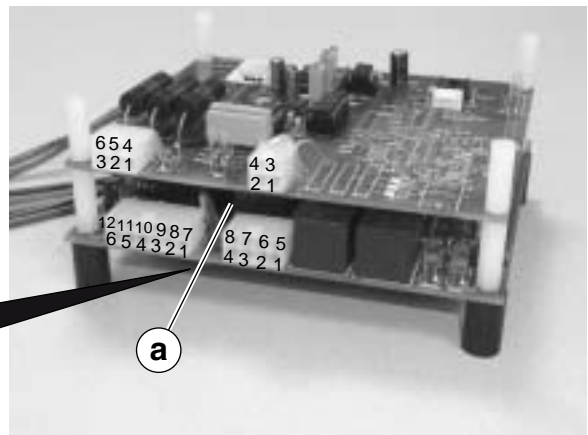
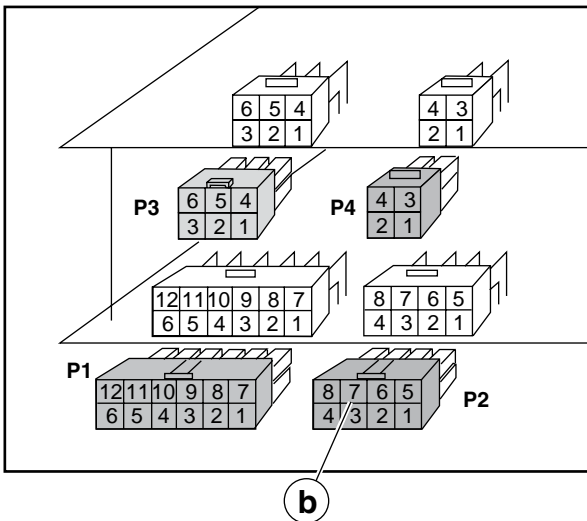

wc\_gr002936

## 6.23 Checking Power to and Operation of Fuel Pump

See Graphic: *wc\_gr002833 and wc\_gr002842*

The 12VDC fuel pump (8) **(d)** is shaped like a small in-line fuel filter and is gold in color. It is located on the “clean” side of the fuel filter and fastened to the side of the engine. The 12VDC fuel pump pulls fuel up from the storage tank, through the fuel filter, and then pushes it into the injection pump.

- 6.23.1 Check the 10A fuse (10) **(c)** to the fuel pump (8) **(d)**. Replace the fuse if necessary.
- 6.23.2 Place the start switch in the START/RUN position and check for 12VDC between red wire #29 at the fuel pump and ground.
  - If 12VDC is not measured, check the continuity of red wires #29 and #27 to and from the 10A fuse and then to the fuel pump. Repair/replace wiring as needed.
  - If 12VDC is measured, continue.
- 6.23.3 Check the continuity and connection of black wire from pump to ground. Repair/replace the wire as required.
- 6.23.4 If 12VDC is present at the pump and the engine still does not start, remove the hose from the engine side of the pump. Place the start switch in the START/RUN position and check if fuel is being pumped out of the hose.
  - If fuel is not being pumped out of the hose, check the fuel lines for clogs and check the condition of the fuel filter. Repair the lines and/or replace the filter as needed. Then, replace the fuel pump if necessary.
  - If fuel is being pumped out of the hose, check the condition of the fuel solenoid (9) **(e)**. See section *Checking Fuel Solenoid*.

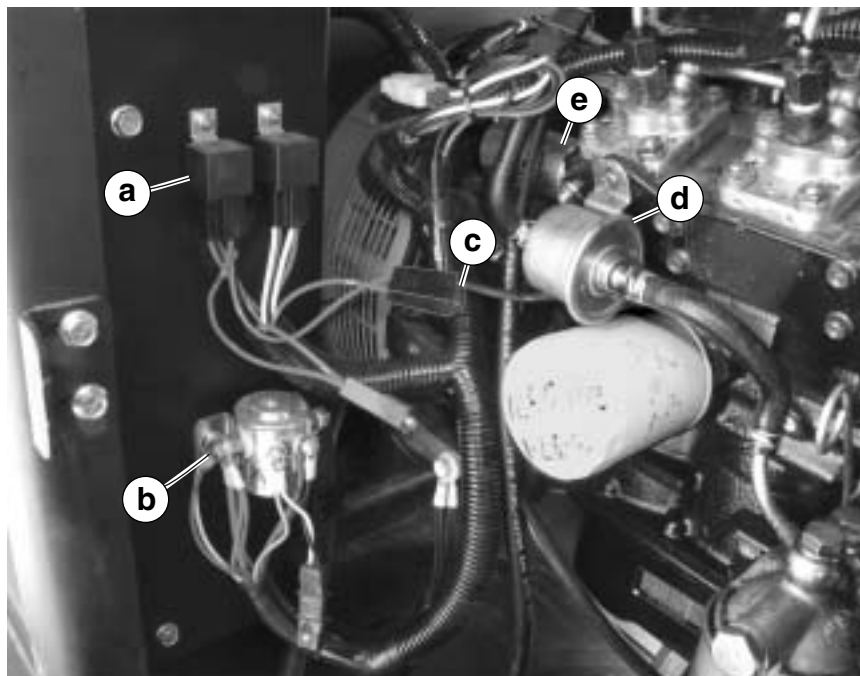

wc\_gr002842

## 6.24 Isuzu Fuel Solenoid

See Graphic: *wc\_gr002833*, *wc\_gr002844*, and *wc\_gr002031*

The fuel solenoid **(a)** is a gold-colored, cylinder-shaped electro-mechanical device that moves a fuel control lever inside the injection pump. It is fastened to the side of the injection pump housing. When energized, the solenoid plunger overcomes a spring and is drawn into the solenoid magnetically. With the fuel solenoid plunger pulled in, the fuel control lever allows full flow of diesel fuel to the injectors. When the solenoid is de-energized and the spring-loaded plunger returns to its resting position, all fuel flow ceases and the engine stops quickly.

Inside the solenoid are two coils. The white wire feeds the high power “pull-in” circuit and the red wire feeds the low power “hold-in” circuit via a 25A fuse (11). If the solenoid has a fourth wire that is blue, it is not used.

The solenoid’s white wire (“pull-in” circuit) is energized by the starter relay (16). Twelve Volts DC is present as long as the starter motor (21) is energized. Like the starter motor, the white wire circuit has a short duty cycle and will be damaged if energized too long. The ECM controls how long they are energized.

The solenoid’s red wire (“hold-in” circuit) is energized by the fuel pump relay (15). Like the fuel pump (8), it has a long duty cycle and can be energized as long as desired. The ECM stops the engine by de-energizing the fuel pump relay, thus removing power to the fuel pump and the fuel solenoid “hold-in” circuit simultaneously.

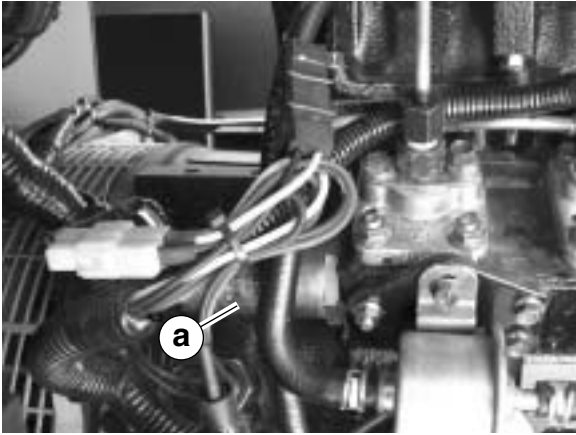

wc\_gr002844



wc\_gr002031

## 6.25 Checking Fuel Solenoid

See Graphic: *wc\_gr002833* and *wc\_gr002852*

- 6.25.1 Check the 25A fuse (11) **(d)**. Replace the fuse if it is blown.
- 6.25.2 Place the start switch in the START/RUN position and check for 12VDC (battery voltage approximately 12V) between red wire #28 at the fuel solenoid plug and ground. Also check the continuity of the solenoid plug **(f)**. Repair/replace the wiring or plug as needed.
- 6.25.3 Place the start switch in the START/RUN position and check for 12VDC (battery voltage approximately 12V) between white wire #24 at the fuel solenoid plug and ground. Also check the continuity of the plug **(c)**. Repair/replace the wiring or plug as needed.
- 6.25.4 Check the continuity of the black wire of the solenoid plug to ground. Repair/replace the wiring or plug as needed.
- 6.25.5 If the fuse blows again, check the function of the fuel solenoid diode **(g)**. See section *Checking Diode Across Relay/Solenoid Coil*. Replace the diode if it is malfunctioning.



CAUTION

Burn hazard. The fuel solenoid may be very hot. Allow it to cool before removing it. Handle the solenoid with care.

- 6.25.6 Remove the fuel solenoid from the injection pump housing and perform the following checks:
  - 6.25.7 Check for free solenoid plunger movement by pushing the plunger into the solenoid and letting it spring back out.
    - If the plunger does not move freely, replace the solenoid.
    - If the plunger does move freely, continue.
  - 6.25.8 Momentarily (one to two seconds) energize the white (+) and black (–) solenoid wires with 12VDC.
    - If the plunger does not snap quickly into the solenoid housing when 12VDC is present, replace the solenoid.
    - If the plunger does snap quickly into the solenoid housing, continue.
  - 6.25.9 Energize the red (+) and black (–) solenoid wires and manually push the plunger into the solenoid housing until it hits bottom.
    - If the plunger does not stay held into the solenoid when 12VDC is present, replace the solenoid.
    - If the plunger does stay held into the solenoid, continue.
  - 6.25.10 If the solenoid passed the previous tests, you may have an engine fuel system problem. Consult a local Isuzu dealer for repair.

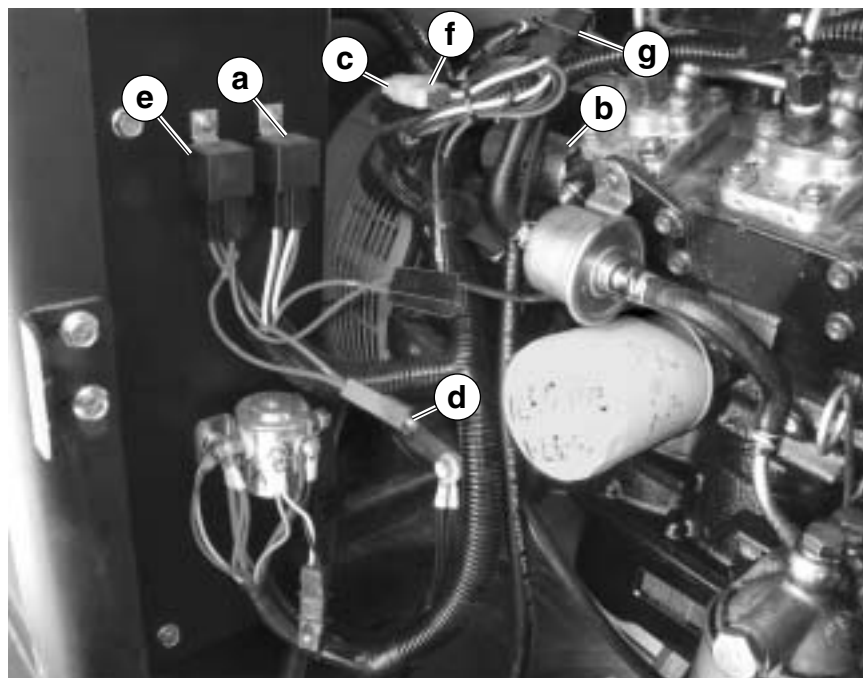

wc\_gr002852

## 6.26 Checking Coil of Fuel Pump Relay

See Graphic: *wc\_gr002843*

- 6.26.1 Place the start switch in the START/RUN position and check for 12VDC (battery voltage approximately 12V) during the cranking cycle between violet wire #34 at terminal 86 of the fuel pump relay **(a)** and ground.
- If 12VDC is not measured, go to step 3.
  - If 12VDC is measured, the coil of the fuel pump relay is receiving power; continue.
- 6.26.2 Check the continuity of black wire #35 from terminal 85 of the fuel pump relay to ground.
- If the wire does not have continuity, repair or replace it.
  - If the wire has continuity, the coil of the fuel pump relay should be functioning.
- 6.26.3 Place the start switch in the OFF position and check the continuity of violet wire #64 from ECM pin 2, plug 2 **(b)**, to terminal 86 of the fuel pump relay.
- If the wire does not have continuity, repair or replace it.
  - If the wire has continuity, continue.
- 6.26.4 Place the start switch in the OFF position and check the continuity of the emergency stop switch **(c)**.
- If the emergency stop switch does not have continuity, replace it.
  - If the emergency stop switch has continuity, continue.
- 6.26.5 Place the start switch in the OFF position and check the continuity of violet wire #64 between the emergency stop switch and terminal 86 of the fuel pump relay.
- If the wire does not have continuity, repair or replace it.
  - If the wire has continuity, continue.
- 6.26.6 Place the start switch in the OFF position and check the continuity of violet wire #64 between the emergency stop switch and ECM pin 2, plug 2.
- If the wire does not have continuity, repair or replace it.
  - If the wire has continuity, there should be power to the coil of the fuel pump relay.

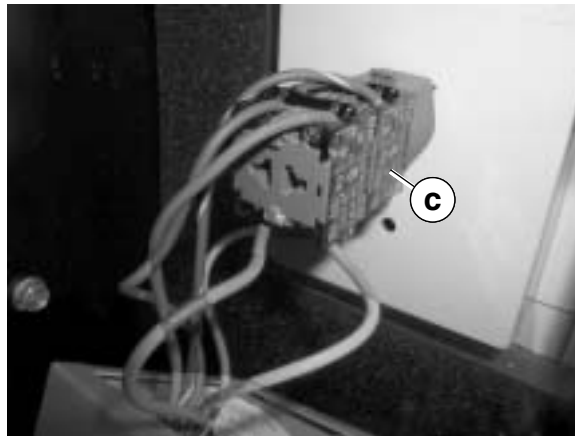
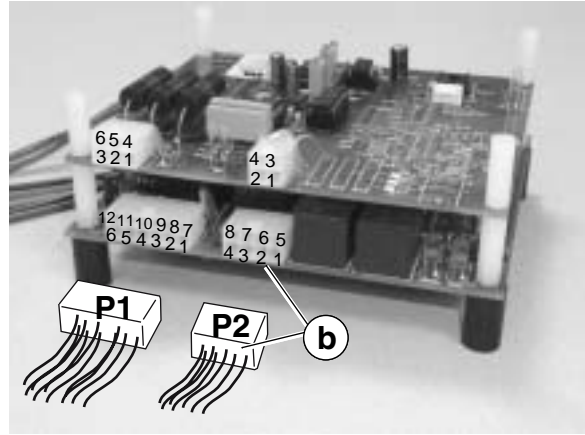
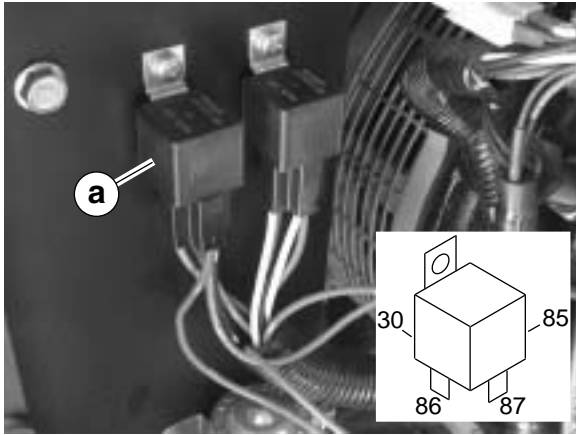

wc\_gr002843

## 6.27 Checking Contacts of ECM Fuel Relay

See Graphic: *wc\_gr002833 and wc\_gr002864*

The ECM has an on-board fuel relay (**a**) which controls power to the coil of the fuel pump relay (15) (**b**). When energized, the fuel pump relay switches 12VDC through a 10A fuse (10) (**c**) to the fuel pump (**d**).

6.27.1 Place the start switch in the START/RUN position and probe pin 2, plug 2 for 12VDC (battery voltage approximately 12V). Measure between pin 2, plug 2 and ground.

- If 12VDC is not measured, replace the ECM.
- If 12VDC is measured, the ECM fuel relay is functioning.

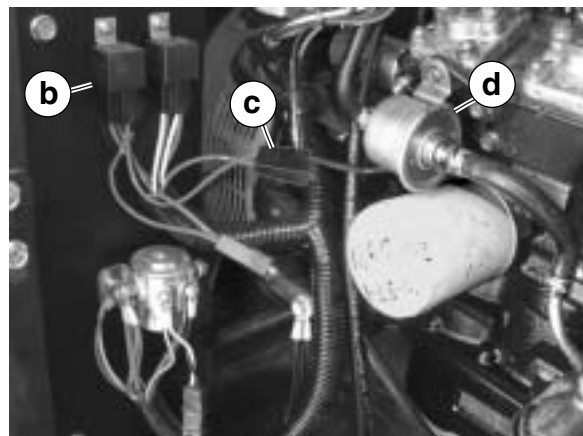
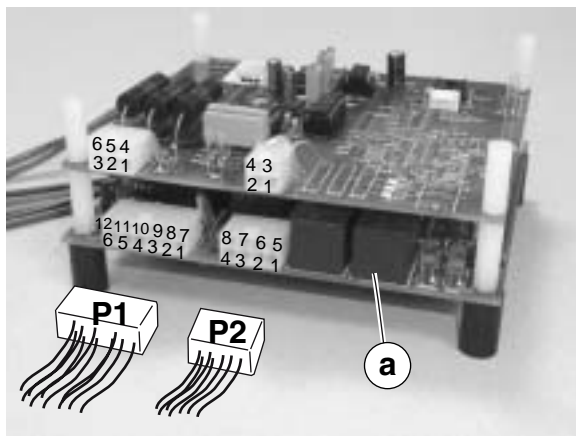

wc\_gr002864

## 6.28 Checking Contacts of Fuel Pump Relay

See Graphic: *wc\_gr002833* and *wc\_gr002842*

6.28.1 Check for 12VDC (battery voltage approximately 12V) between terminal 30 of the fuel pump relay (15) **(a)** and ground.

- If 12VDC is not measured, check the continuity of red wire #31 from terminal 30 of the fuel pump relay to B+ terminal of the glow plug relay (14) **(b)**. Repair/replace the wire as needed.
- If 12VDC is measured, the fuel pump relay is receiving power; continue.

6.28.2 Place the start switch in the START/RUN position and check for 12VDC between terminal 87 of the fuel pump relay and ground during cranking cycle.

- If 12VDC is not measured, replace the fuel pump relay.
- If 12VDC is measured, the fuel pump relay is functioning.

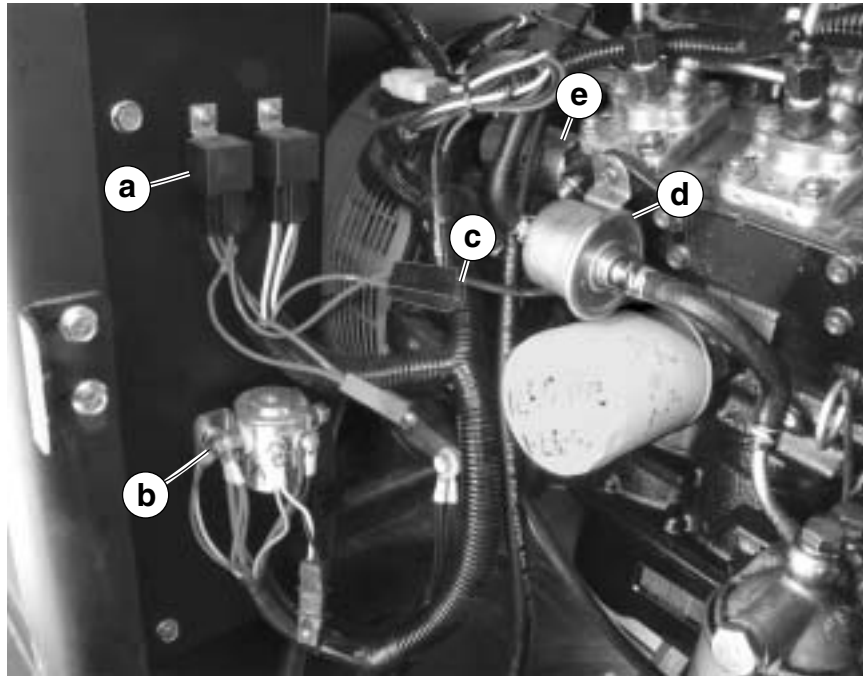

*wc\_gr002842*

6.29 General Engine Troubleshooting—*Isuzu*

Symptom	Problem	Solution
Engine does not crank	Discharged battery	Recharge or replace battery.
	Defective battery cable connections	Replace or repair cables.
	Defective starter and/or wiring	Repair or replace starter and wiring.
Engine cranks but will not start	Exhaust restricted	Check and correct exhaust restriction.
	Fuel filter plugged or full of water	Replace fuel filter or drain water from filter.
	Injection pump not getting fuel or air in fuel system	Check fuel flow at supply pump or bleed fuel system.
	Faulty injection pump or nozzles	Consult authorized diesel repair shop for repair or replacement.
	No fuel	Check fuel tank and hoses.

Symptom	Problem	Solution
Engine hard to start or will not start	Engine starting under load	Place all circuit breakers in OFF positions.
	No fuel	Check fuel tank and hoses.
	Air in fuel line	Bleed fuel line.
	Cold weather	Use cold weather starting aids.
	Crankcase oil too heavy	Use oil of proper viscosity.
	Improper fuel type	Use proper fuel type for operating conditions.
	Water, dirt or air in fuel system	Drain, flush, fill, and bleed fuel system.
	Clogged fuel filter	Replace filter element.
	Dirty or faulty injection nozzles	Have authorized service dealer or distributor check injectors.
	Defective injection pump	Have authorized service dealer or distributor check injection pump.
	Defective glow plug(s)	Repair or replace glow plugs.
Engine knocks	Low engine oil level	Add oil to engine crankcase.
	Injection pump out of time	See authorized service dealer or distributor.
	Low coolant temperature	Remove and check thermostat.
	Engine overheating	See "Engine overheats" symptom in this chart.

Symptom	Problem	Solution
Engine runs irregularly or stalls frequently	Low coolant temperature	Remove and check thermostat.
	Clogged fuel filter	Replace fuel filter element.
	Water, dirt, or air in fuel system	Drain, flush, fill, and bleed system.
	Dirty or faulty injection nozzles	Have authorized servicing dealer or engine distributor check injectors.
Lack of power	Engine overloaded	Reduce load.
	Intake air restriction	Service air cleaner.
	Clogged fuel filter	Replace filter elements.
	Improper type of fuel	Use proper fuel.
	Overheated engine	See "Engine Overheats" symptom in this chart.
	Below normal engine temperature	Remove and check thermostat.
	Improper valve clearance	See authorized dealer or distributor.
	Dirty or faulty injection nozzles	Have authorized service dealer or distributor check injectors.
	Injection pump out of time	See authorized dealer or distributor.
	Leaking exhaust manifold gasket	See authorized dealer or distributor.
	Restricted fuel hose	Clean or replace fuel hose.
Engine emits white smoke	Improper fuel type	Use proper fuel.
	Fuel mixed with water	Replace fuel.
	Defective injection nozzles	See authorized dealer or distributor.
	Engine out of time	See authorized dealer or distributor.

Symptom	Problem	Solution
Engine emits black smoke.	Improper fuel type	Use proper fuel.
	Clogged or dirty air cleaner	Service air cleaner.
	Engine overloaded	Reduce load.
	Injection nozzles dirty	See authorized dealer or distributor.
	Engine out of time	See authorized dealer or distributor.
Engine overheats	Engine overloaded	Reduce load.
	Low coolant level	Fill radiator to proper level. Check radiator and hoses for loose connections and leaks.
	Stretched fan belt or defective belt tensioner	Check automatic belt tensioner and check belts for stretching. Replace belts as required.
	Low engine oil level	Check oil level. Add oil as required.
	Cooling system needs flushing	Flush cooling system.
	Defective thermostat	Remove and check thermostat.
	Defective temperature gauge or sender	Check water temperature with thermometer and replace temperature gauge or sender as required.
	Incorrect grade of fuel	Use correct grade of fuel.

**Notes**

## 7. John Deere Engines without ECU

### 7.1 John Deere Engine Background

See Graphic: *wc\_gr002004*

The John Deere engines used on generator models G 50, G 70, and G 85 (item 0009310) do not include an electronic Engine Control Unit (ECU). These engines use a mechanical fuel pump, an intake air heater as a starting aid, and an internal electric fuel valve for engine run/stop control.

The intake air heater is in line with the air intake manifold located near the top of the engine. It warms the air entering the engine cylinders and aids in fuel/air mixture ignition when the engine is cold. After the start switch is moved into the START/RUN position, the Engine Control Module (ECM) goes through a boot-up sequence, checks inputs from the various sensors, and sends power to the air intake heater if need be. The ECM controls the duration the heater is energized based on the engine coolant temperature. The colder the coolant temperature, the longer the heater is energized. The heater is energized only during the first cycle of three automatic starting attempts. When in this state, the red LED near the stop sign on the front of the control panel will be lit indicating the ECM is attempting to energize the heater.



7.2 Engine Wiring Diagram—John Deere without ECU

This schematic will be referred to throughout this chapter.

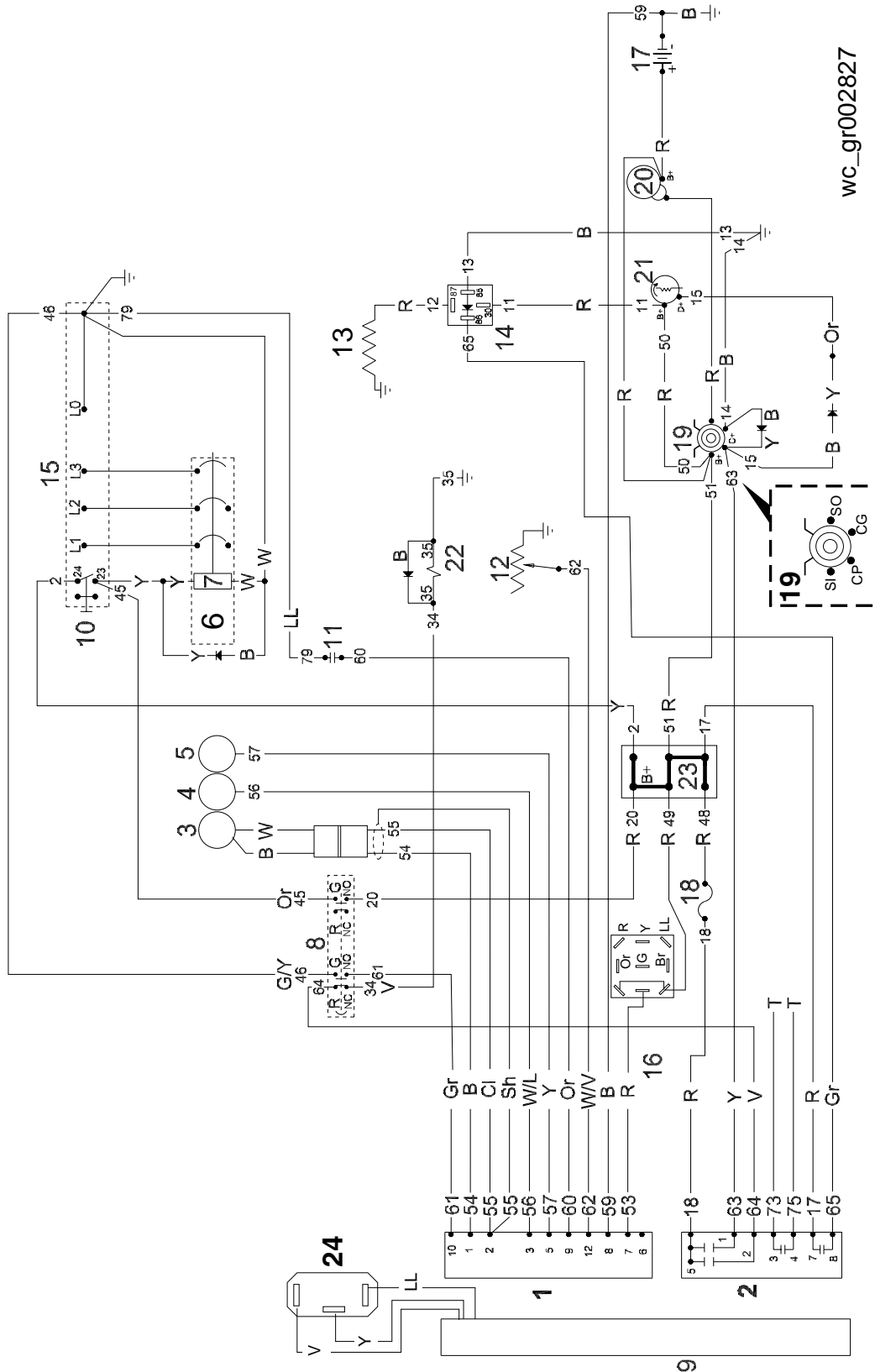

7.3 Engine Wiring Components—*John Deere without ECU*

See Graphic: *wc\_gr002827*

Ref.	Description	Ref.	Description
1	Plug 1 — engine sender inputs	13	Intake heater
2	Plug 2 — engine start outputs	14	Slave preheat relay
3	Magnetic pickup	15	Mechanical lugs
4	Oil pressure sender	16	Start/run switch
5	Coolant temperature sender	17	Battery
6	Main circuit breaker	18	10A fuse
7	Shunt trip, main breaker	19	Starter relay
8	Emergency stop switch	20	Starter
9	Engine Control Module (ECM)	21	Alternator
10	Lug door switch	22	Fuel solenoid
11	Remote start terminals	23	Terminal strip
12	Fuel level sender	24	Hour meter switch

ECM Plug 1 Wires			ECM Plug 2 Wires		
Pin	Wire	Description	Pin	Wire	Description
10	Gr/61	Emergency stop	5	R/18	Battery + (for relays)
1	B/54	Magnetic pickup ground	1	Y/63	Crank (12V output)
2	Cl/Sh/55	Magnetic pickup sensing	2	V/64	Run/fuel (12V output)
3	W/I/56	Crank delay, preheat	3	73	Remote annunciator (NA)
5	Y/57	Water temperature	4	75	Remote annunciator (NA)
9	Or/60	Remote start	7	R/17	Battery + (for terminal strip)
12	W/V/62	Fuel level	8	Gr/65	Preheat
8	B/59	Battery –	-	-	---
7	R/53	Battery + (for ECM board)	-	-	---
6	-	(not used)	-	-	---

7.4 Locations of Engine Electrical Components

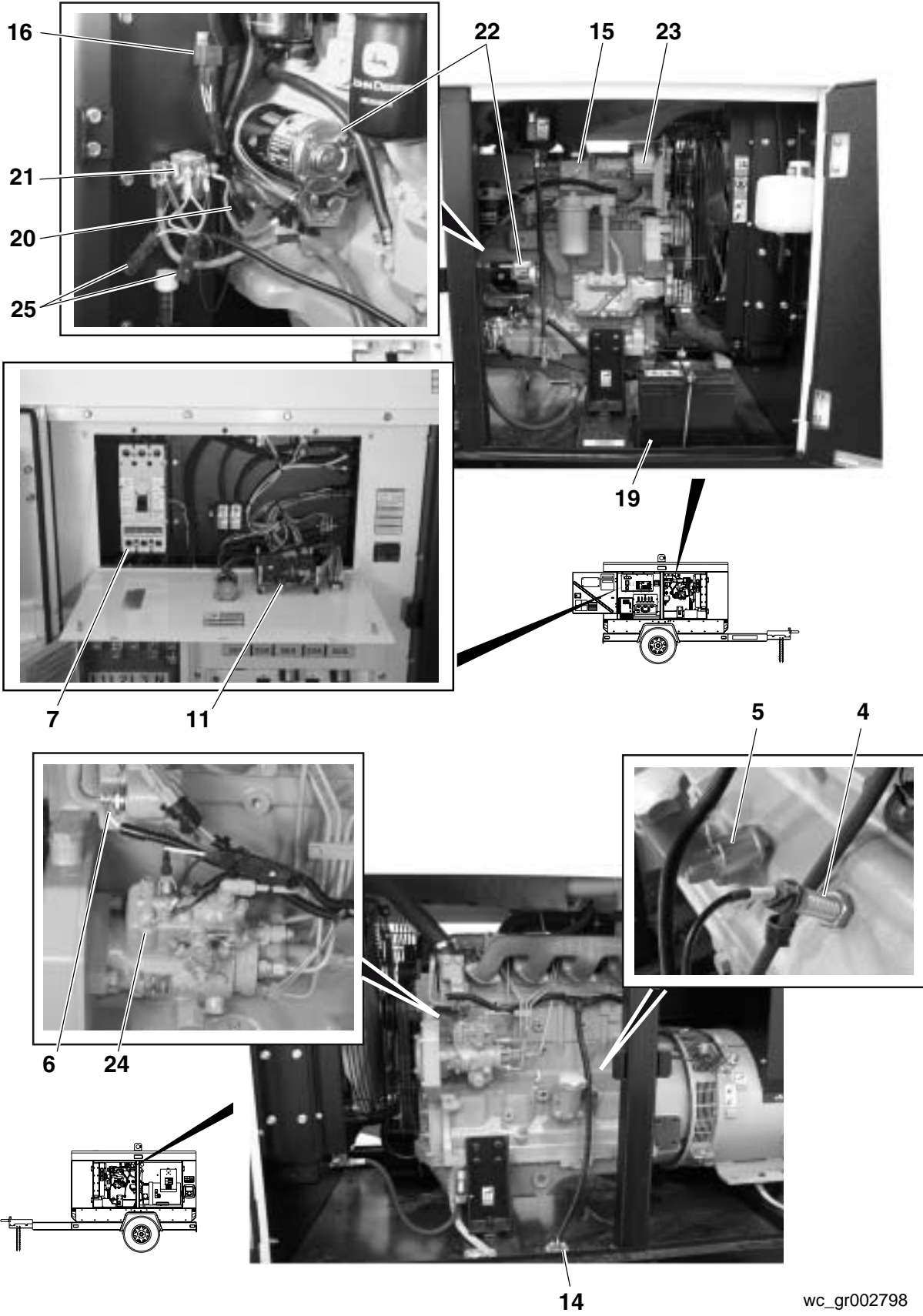

wc\_gr002798

## 7.5 Engine Electrical Components

See Graphic: wc\_gr002798

Ref.	Component	Ref.	Component
4	Magnetic pickup	19	Battery
5	Oil pressure sender	20	10 A fuse
6	Coolant temperature sender	21	Starter relay
7	Main circuit breaker	22	Starter
11	Engine Control Module (ECM)	23	Alternator
14	Fuel level sender	24	Fuel solenoid
15	Intake manifold heater	25	Diodes
16	Slave preheat relay	-	---

## 7.6 Troubleshooting Flowcharts

The troubleshooting flowcharts are designed to take you through the process of determining the source of a problem with engine starting or machine operation. Many of the tests involve live voltages and therefore should only be attempted by qualified personnel. Detailed procedures for carrying out the tests are included in this manual. All highlighted text within the flowcharts have matching sections in this manual.

7.7 Engine Troubleshooting—John Deere without ECU

Engine Troubleshooting  
Flowchart 2A  
John Deere without ECU

\* Battery voltage;  
approximately 12V.

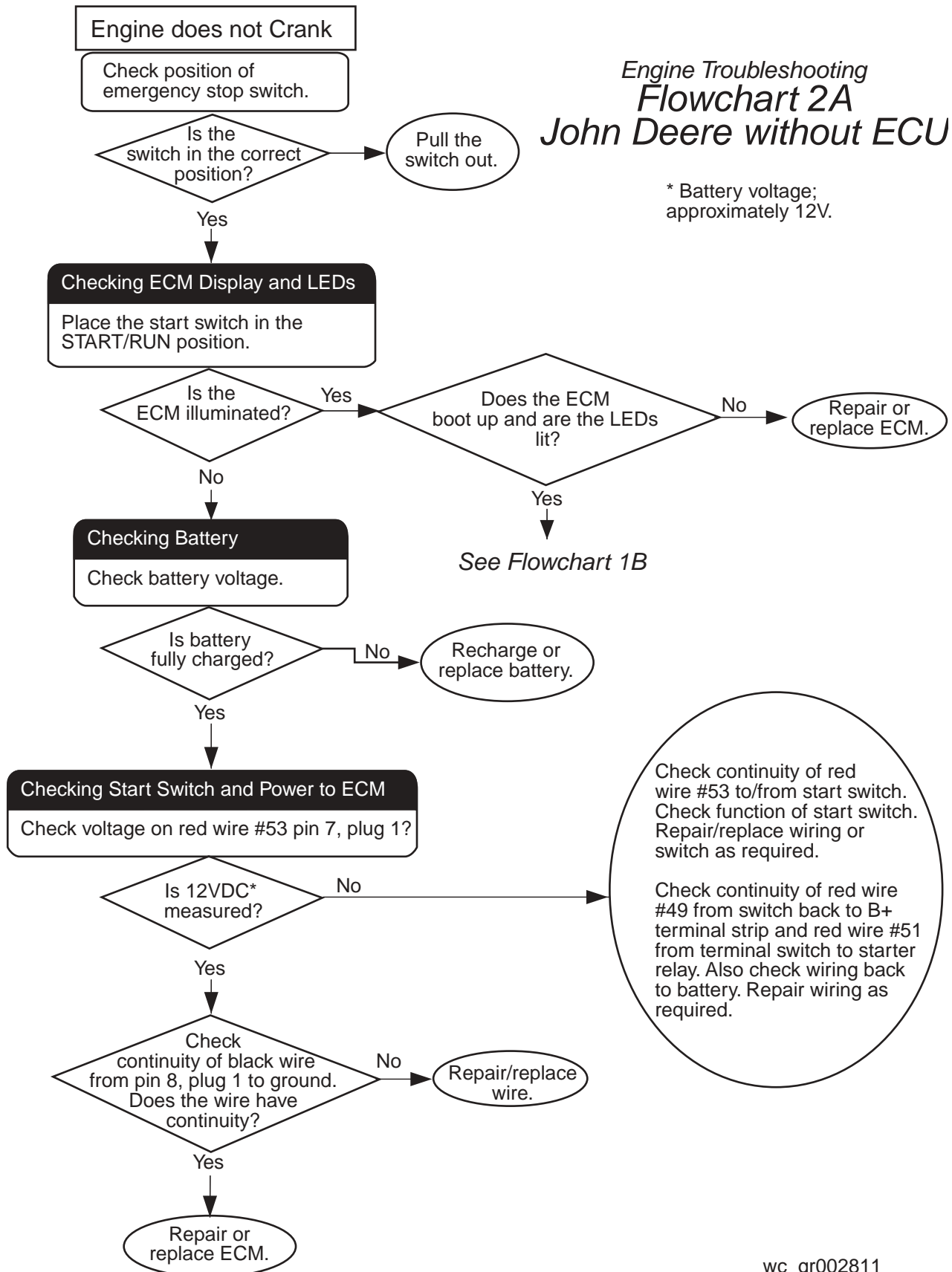

Check continuity of red wire #53 to/from start switch. Check function of start switch. Repair/replace wiring or switch as required.

Check continuity of red wire #49 from switch back to B+ terminal strip and red wire #51 from terminal switch to starter relay. Also check wiring back to battery. Repair wiring as required.

wc\_gr002811

*Engine Troubleshooting  
Flowchart 2B  
John Deere without ECU*

*Engine does not Crank  
Continued from Flowchart 1A*

\* Battery voltage;  
approximately 12V.

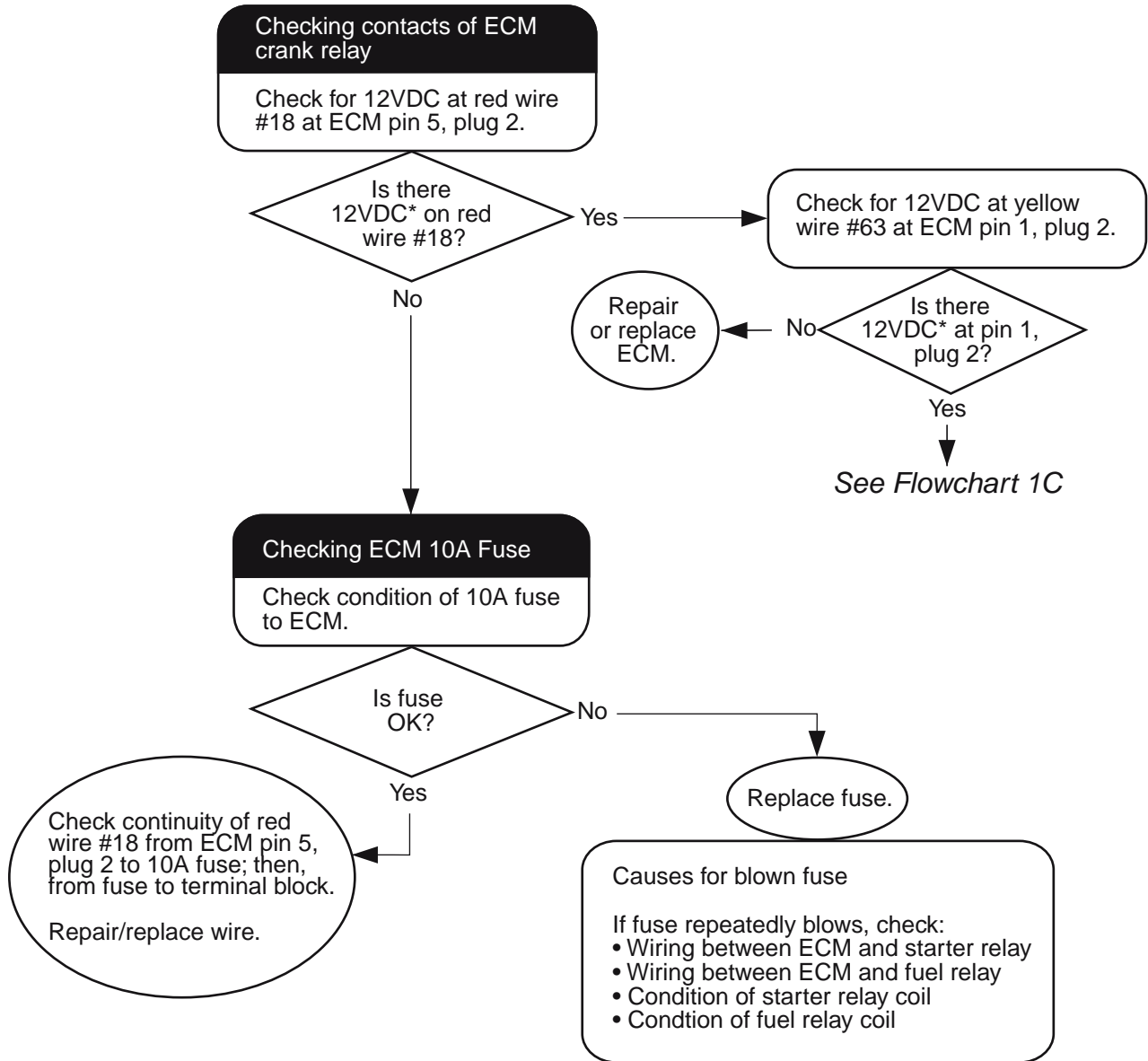

wc\_gr002831

Continued from Flowchart 2B  
 Engine does not Crank

Engine Troubleshooting  
**Flowchart 2C**  
 John Deere without ECU

\* Battery voltage approximately 12V

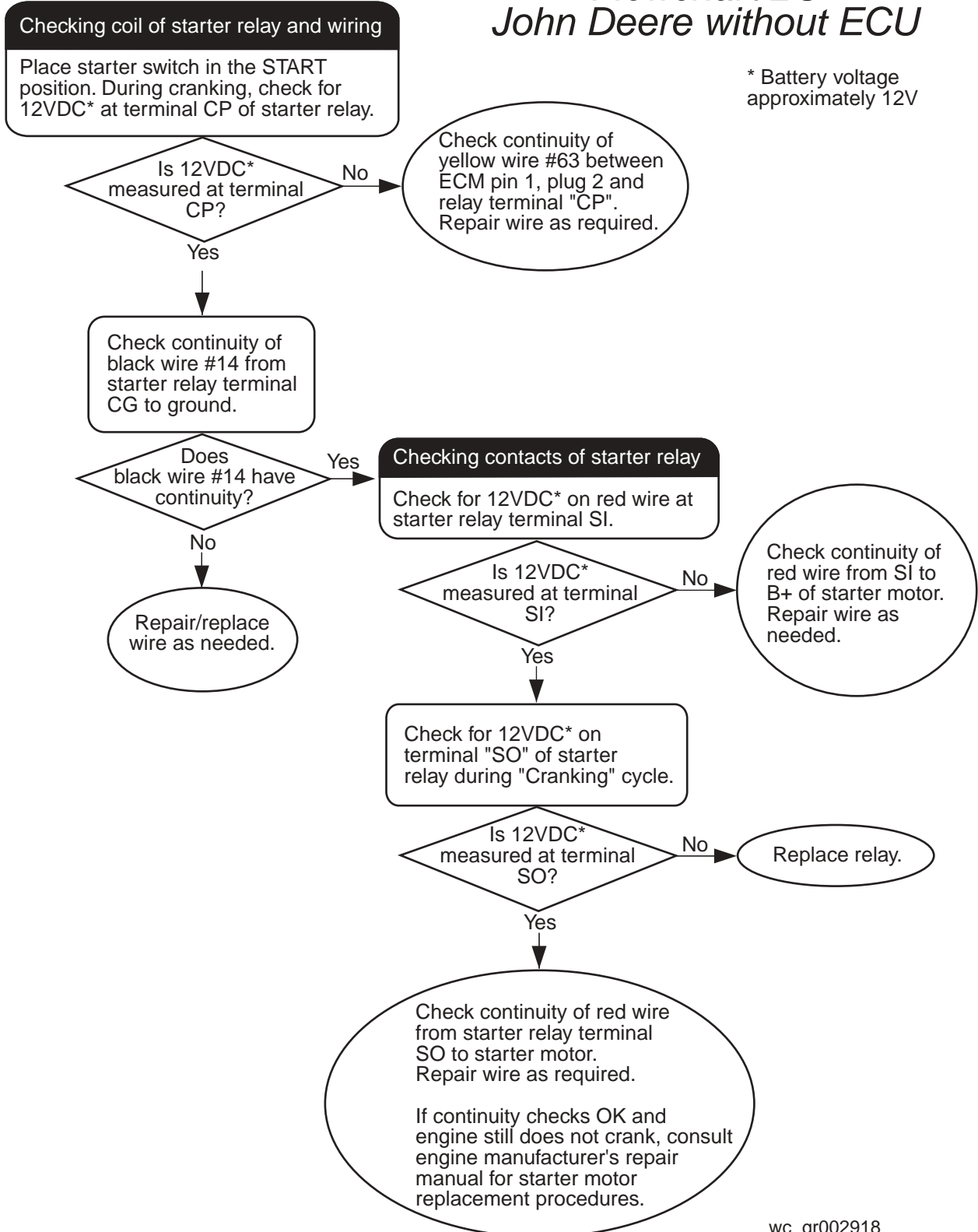

wc\_gr002918

## 7.8 Checking Wiring Continuity

When checking the continuity of a wire, use the Ohms scale on your checking instrument (multimeter). A reading of less than one Ohm means the wire has continuity and should be OK. A reading over one Ohm usually means that the wire or connectors are corroded and should be repaired or replaced. A reading of "OL" or "OPEN" means the wire is broken and there is no continuity. In such cases, repair or replace the wire.

## 7.9 Probing Plugs and Pins

See Graphic: *wc\_gr002926*

To measure the voltage at an ECM pin, attach an appropriate extension **(a)** to the positive probe on your multimeter. Slide the positive probe into the plug along the wire of the pin to be tested. Use care when testing this way so you don't damage the wire, plug, or ECM. Find a suitable ground on the machine's frame for the negative probe **(b)** of your multimeter.

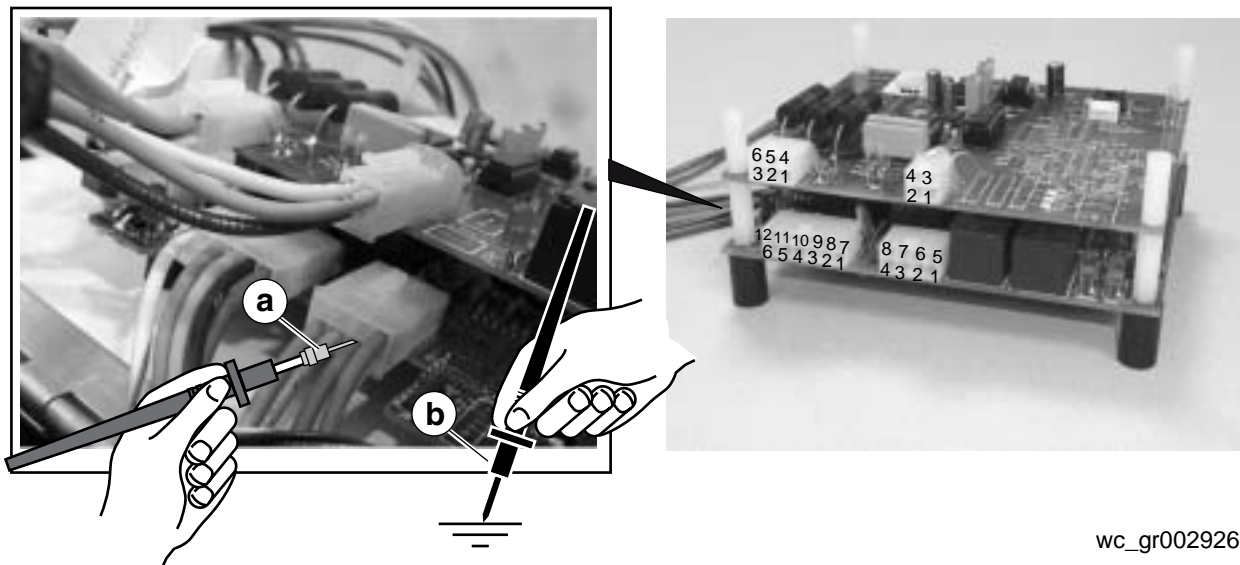

wc\_gr002926

## 7.10 Checking ECM Display and LEDs

See Graphic: *wc\_gr002799*

After placing the start switch in the START/RUN position, the ECM goes through a boot-up sequence. On early machines the ECM displays “Preheating”, then “Cranking”. Later model machines display “Initializing...”, “Time to Service”, and then “Cranking \_ of 3”. During the preheat cycle (heater activation), the LED **(b)** near the stop sign illuminates.

To check the general condition of the ECM, carry out the following procedures:

- 7.10.1 Remove the three screws **(a)** securing the control panel and open the panel.
- 7.10.2 Check the condition of all ECM connectors (plugs) and wiring. Make sure wires are secure in the plugs and that the plugs are connected securely to the ECM. Also look for burn marks, melting, and signs of damage; repair or replace wiring/plugs as needed.
- 7.10.3 Place the start switch in the START/RUN position.
  - If the ECM display does not illuminate, check the battery. See section *Checking Battery*.
  - If the ECM display does illuminate, continue.
- 7.10.4 Place the start switch in the START/RUN position and check that the ECM display illuminates and that the boot-up sequence has started.
  - If the ECM does not go through the boot-up sequence, the ECM may be malfunctioning. Repair or replace the ECM. Call Wacker Service.
  - If the ECM goes through the boot-up sequence, continue.
- 7.10.5 Locate the two red LEDs **(c)** on the left side of the lower ECM circuit board. Place the start switch in the OFF position then in the START/RUN position. Check that the “FUEL” LED illuminates after the preheat period has ended and stays lit for the entire cranking period. Also check that the “CRANK” LED illuminates when the engine is attempting to crank.
  - If the LEDs do not illuminate as described above, the ECM may be malfunctioning. Repair or replace the ECM. Call Wacker Service.

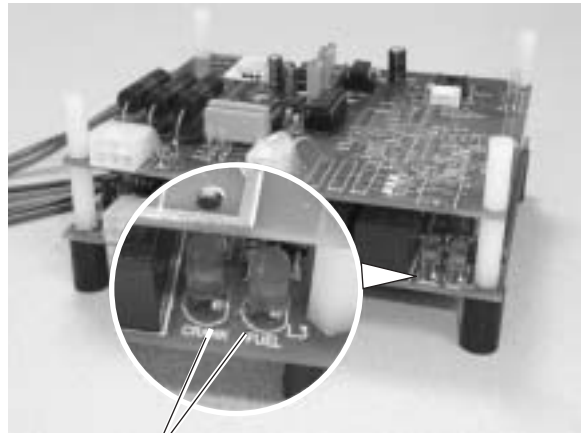
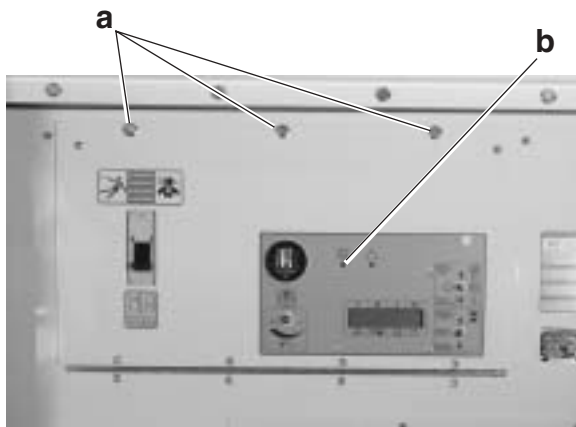

wc\_gr002799

## 7.11 Checking Battery

The ECM display may or may not be blank when the battery voltage is less than 12V. During such a condition, the battery may be charged enough to light the display, but not enough to fully crank the starter.

- 7.11.1 Check that the battery cable connections are tight.
- 7.11.2 Check the battery terminals for corrosion. Clean the terminals if necessary. Corroded terminals and loose connections will result in hard starting and insufficient battery charge.
- 7.11.3 Check the battery for proper voltage: 11–13V.
- 7.11.4 Charge or replace the battery if needed.

**CAUTION:** Do not jump-start the machine using a battery or charging system with greater than 12–14V. Damage to the machine's electrical system will occur.

**CAUTION:** Do not jump start the machine without a battery connected. Damage to the machine's electrical system will occur.

## 7.12 Checking Power to ECM

See Graphic: *wc\_gr002827* and *wc\_gr002800*

- 7.12.1 Place the start switch (16) in the START/RUN position and check for 12VDC (battery voltage approximately 12V) between red wire #53 at pin 7, plug 1 and ground.
- If 12VDC is measured, the ECM is receiving power. Go to step 8.
  - If 12VDC is not measured, continue.
- 7.12.2 Place the start switch in the OFF position and check the continuity of red wire #53 from pin 7, plug 1 to the start switch.
- If the wire does not have continuity, repair or replace it.
  - If the wire has continuity, continue.
- 7.12.3 Check the start switch. Remove the red wires **(a)** and check terminals for continuity—outer terminals to center (only one pair of terminals per switch position).
- If the switch does not have continuity, repair or replace it.
  - If the switch has continuity, continue.
- 7.12.4 Check the continuity of red wire #49 between the start switch and the terminal block (23) **(b)**.
- If the wire does not have continuity, repair or replace it.
  - If the wire has continuity, continue.
- 7.12.5 Check the continuity of red wire #51 between the terminal block and the starter relay (19) **(c)**.
- If the wire does not have continuity, repair or replace it.
  - If the wire has continuity, continue.
- 7.12.6 Check the continuity of the red wire between the starter relay and the starter motor (20) **(d)**.
- If the wire does not have continuity, repair or replace it.
  - If the wire has continuity, continue.
- 7.12.7 Check the continuity of the red wire between the starter motor and the battery (17).
- If the wire does not have continuity, repair or replace it.
  - If the wire has continuity, continue.
- 7.12.8 Check the continuity of black wire #59 from pin 8, plug 1 to ground.
- If the wire does not have continuity, repair or replace it.
  - If the wire has continuity and the ECM is receiving power, the ECM should be functioning. If it is not, repair or replace it. Call Wacker Service.

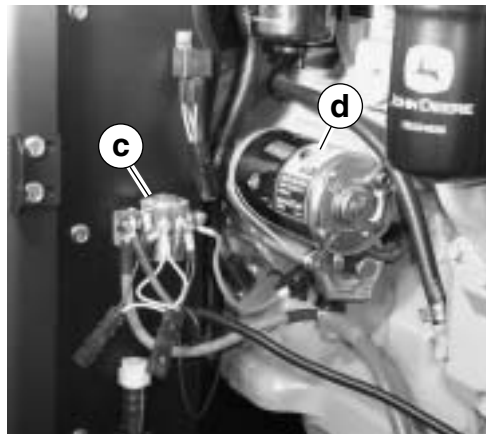
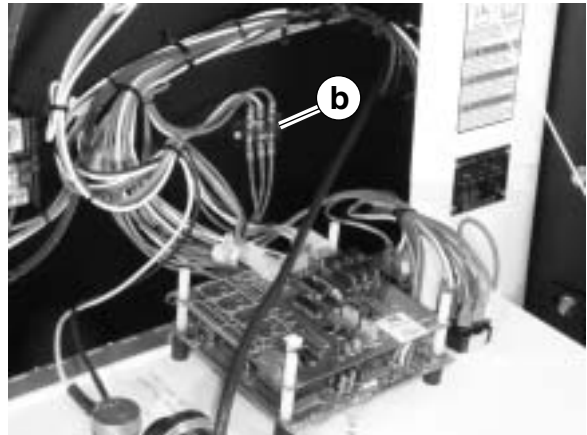
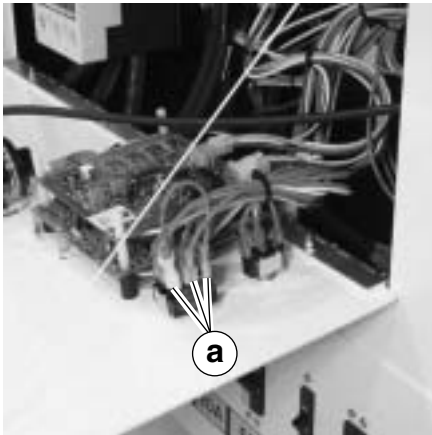
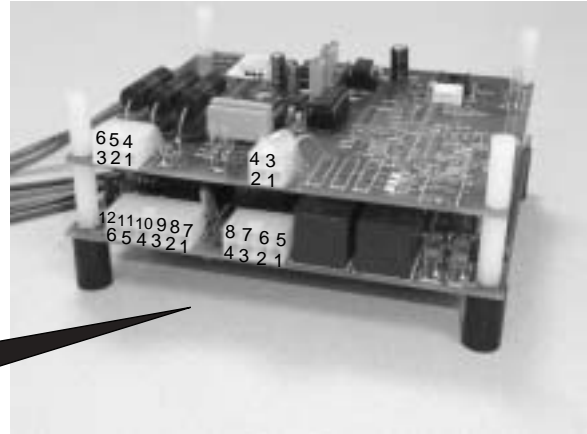
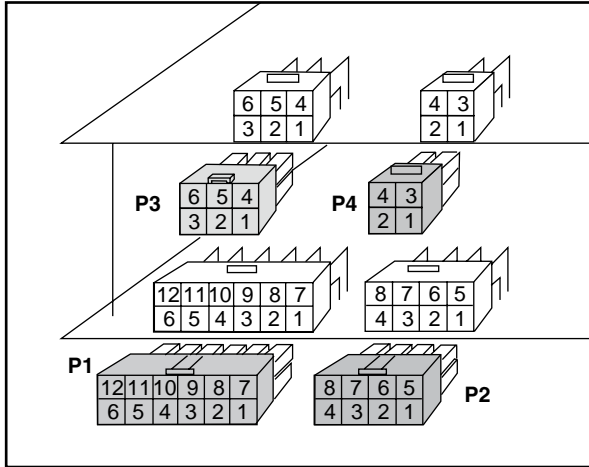

wc\_gr002800

### 7.13 Checking Contacts of ECM Crank Relay

See Graphic: *wc\_gr002827* and *wc\_gr002829*

When the start switch is placed in the START/RUN position, the ECM crank relay **(c)** energizes. The ECM crank relay supplies 12VDC through yellow wire #63 to energize the starter relay (14).

- 7.13.1 Check for 12VDC (battery voltage approximately 12V) between red wire #18 at pin 5, plug 2 and ground.
- If 12VDC is measured, the ECM relay contact circuit is receiving power. Go to step 5.
  - If 12VDC is not measured, continue.
- 7.13.2 Check the ECM 10A fuse (18)**(a)**.
- If the fuse is blown, see section *Checking ECM 10A Fuse*.
  - If the fuse is OK, continue.
- 7.13.3 Check continuity of red wire #18 from ECM pin 5, plug 2 to the 10A fuse.
- If the wire does not have continuity, repair or replace it.
  - If the wire has continuity, continue.
- 7.13.4 Check the continuity of red wire #48 from the 10A fuse to the B+ terminal strip **(b)**.
- If the wire does not have continuity, repair or replace it.
  - If the wire has continuity, continue.
- 7.13.5 Place the start switch in the START/RUN position and probe yellow wire #63 at pin 1, plug 2 for 12VDC during the cranking cycle.
- If 12VDC is measured, the ECM crank relay contact circuit is functioning.
  - If 12VDC is not measured, the ECM is malfunctioning; repair or replace it. Call Wacker Service.

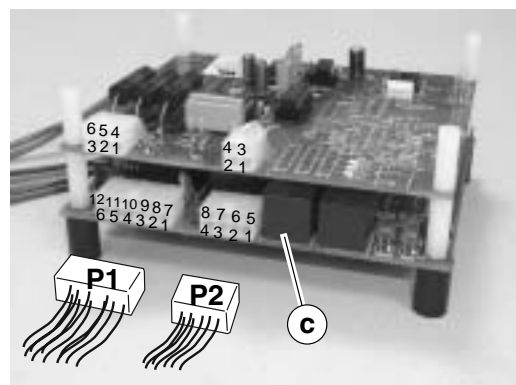
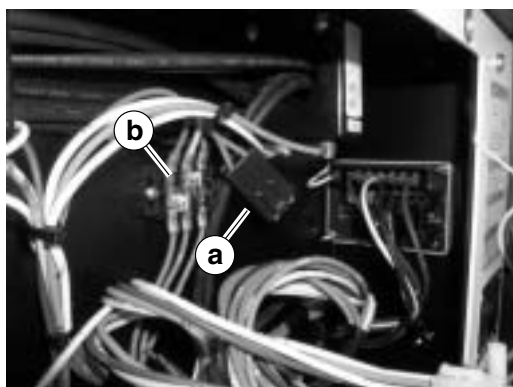

*wc\_gr002829*

## 7.14 Checking ECM 10A Fuse

See Graphic: *wc\_gr002802*

The 10A fuse is found in the control compartment on G25 models **(a)**. It is found in the engine compartment on all other models **(b)**. There is 12VDC fed through this fuse to the ECM fuel and crank relay contacts via ECM pin 5, plug 2. If the fuse repeatedly blows, it is a sign that there is a short in the wires to/from the ECM, a diode is faulty, or the fuel or starter relay is shorted.

7.14.1 Check the 10A fuse. If it is blown, check:

- The condition of the wiring to/from the fuse. Repair or replace the wiring as needed.
- On Isuzu-powered generators, check the condition of the starter relay coil (see section *Checking Coil of Starter Relay and Wiring*); condition of the fuel relay coil (see section *Checking Coil of Fuel Pump Relay*). Also check for failed diodes. See section *Checking Diode Across Relay/Solenoid Coil*.
- On Deere-powered generators, check the condition of the starter relay coil (see section *Checking Coil of Starter Relay and Wiring*); and the condition of the fuel solenoid (see section *Checking Fuel Solenoid*). Also check for failed diodes. See section *Checking Diode Across Relay/Solenoid Coil*.

7.14.2 Once the wiring, relay/solenoid coils, and diodes check OK, replace the 10A fuse.

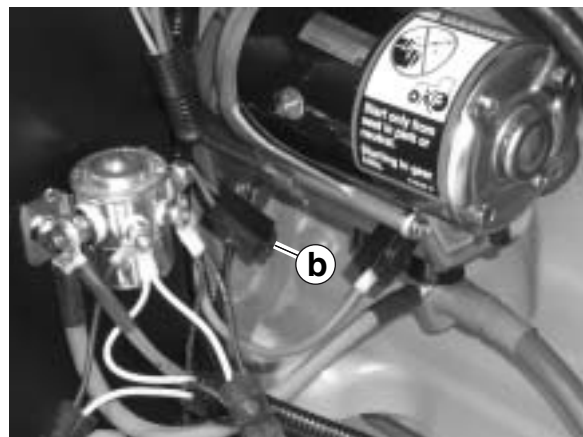
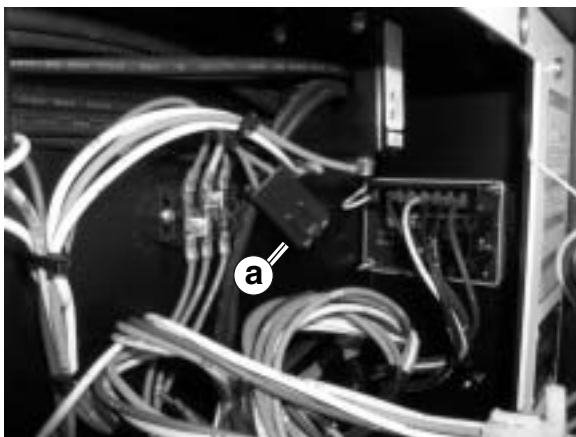

*wc\_gr002802*

## 7.15 Checking Diode Across Relay/Solenoid Coil

See Graphic: *wc\_gr002803*

The glow plug relay **(a)** and the fuel solenoid **(b)** on Isuzu powered generators, and the starter relay **(c)** (and fuel solenoid **(d)** on John Deere engines without the Engine Control Unit (ECU)), all have a diode **(e)** similar to the one pictured connected across the coil. The diodes are encapsulated in rubber. They are installed in the circuit to redirect a voltage spike to ground if one should occur during powering down the relay's coil. In order to check the diode, separate the diode portion from the connector portion.

**Note:** *Replacement diodes come with the connector portion and wiring. It is permissible to remove and discard the replacement connector portion and insert the replacement diode into the existing connector and wiring.*

- 7.15.1 Using the diode scale on a multimeter, check that the diode conducts in only one direction and not in the other. The meter should read 0.450–0.550V in one direction and “OL” or “OPEN” in the other. Replace the diode if necessary.
- 7.15.2 On “can style” relays (the glow plug relay on G 25, the starter relay on all other generators), check that the yellow wire of the diode is attached to the power terminal of the relay's coil (labeled “CP” on the schematic) and that the black wire is attached to the ground terminal of the relay's coil (labeled “CG” on the schematic). Correct the wiring as needed.

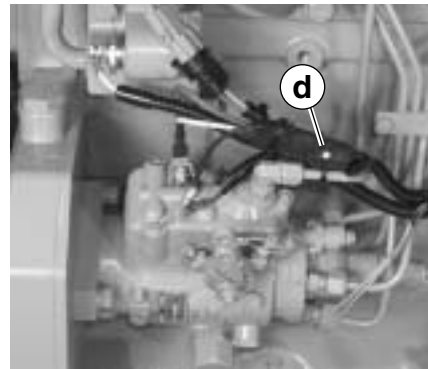
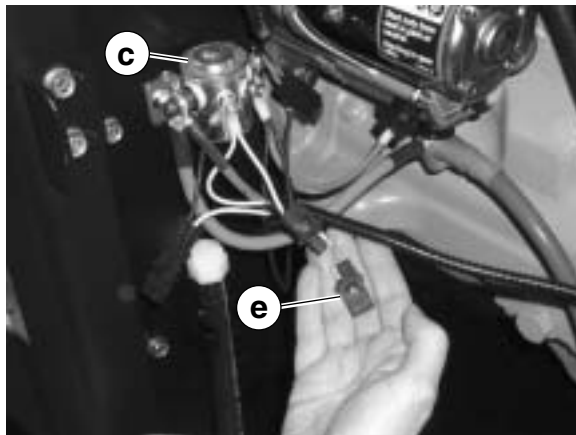
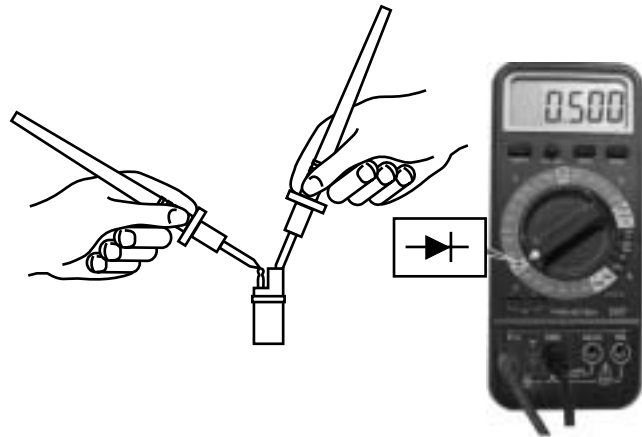
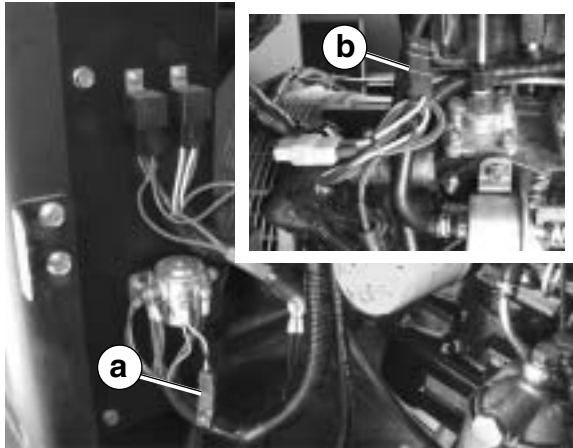

wc\_gr002803

## 7.16 Checking Coil of Starter Relay and Wiring

See Graphic: *wc\_gr002827* and *wc\_gr002865*

- 7.16.1 Disconnect the wiring from the starter relay (16) terminals CP **(a)** and CG **(b)** and check the resistance across terminals CP and CG.
- If  $100\pm 10\%$  is not measured, replace the starter relay.
  - If  $100\pm 10\%$  is measured, continue.
- 7.16.2 Reconnect the wiring to the starter relay terminals CP and CG. Place the start switch in the START/RUN position. During the cranking cycle, check for 12VDC (battery voltage approximately 12V) between terminal CP and ground.
- If 12VDC is measured, the coil of the starter relay is receiving power. Go to step 4.
  - If 12VDC is not measured, continue.
- 7.16.3 Check the continuity of yellow wire #63 from ECM pin 1, plug 2 to terminal CP of the starter relay.
- If the wire does not have continuity, repair or replace it.
  - If the wire has continuity, continue.
- 7.16.4 Check the continuity of black wire #14 between the starter relay terminal CG and ground.
- If the wire does not have continuity, repair or replace it.
  - If the wire has continuity, the starter relay's coil should be functioning.

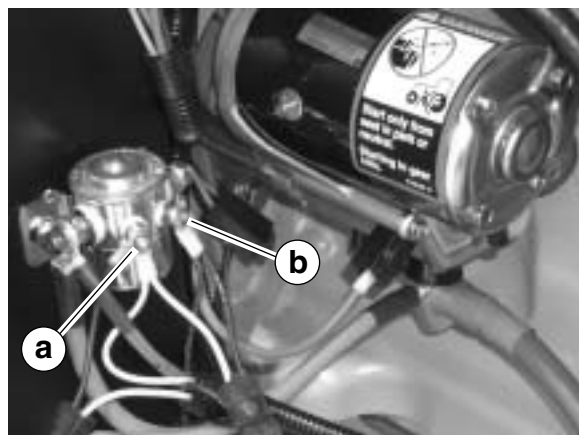
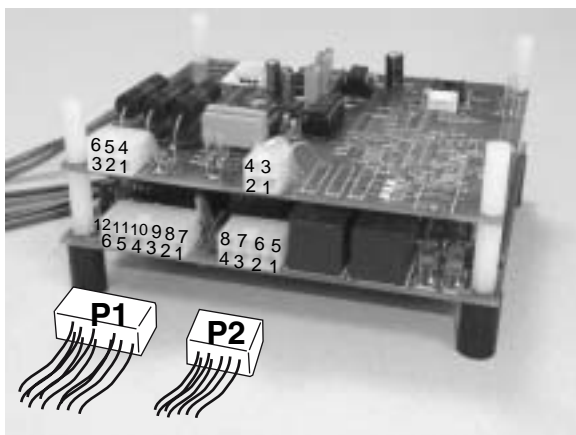

*wc\_gr002865*

## 7.17 Checking Contacts of Starter Relay and Wiring

See Graphic: *wc\_gr002827* and *wc\_gr002805*

The starter relay coil and its wiring must be functioning properly before checking the starter relay contacts. See section *Checking Starter Relay Coil and Wiring*.

- 7.17.1 Check for 12VDC (battery voltage approximately 12V) between the red wire #51 at terminal B+ (SI) **(a)** of the starter relay and ground.
- If 12VDC is not measured, check continuity of red wire #51 from terminal B+ of the starter relay to terminal B+ of the starter motor. Repair wiring as needed.
  - If 12VDC is measured at terminal B+ (SI), continue.
- 7.17.2 Place the start switch in the START/RUN position and during the ECM cranking cycle check for 12VDC between terminal SO **(b)** of the starter relay and ground.
- If 12VDC is not measured at terminal SO of the starter relay during the cranking cycle, replace the starter relay.
  - If 12VDC is measured at terminal SO of the starter relay during the cranking cycle, the starter relay is functioning.
- 7.17.3 Place the start switch in the START/RUN position and during the cranking cycle check for 12VDC between red wire at the starter motor solenoid **(c)** and ground.
- If 12VDC is not measured, check continuity of red wire. Repair or replace the wire as needed.
  - If 12VDC is measured, and the engine still doesn't crank, check the engine manufacturer's service manual for starter motor replacement procedures.

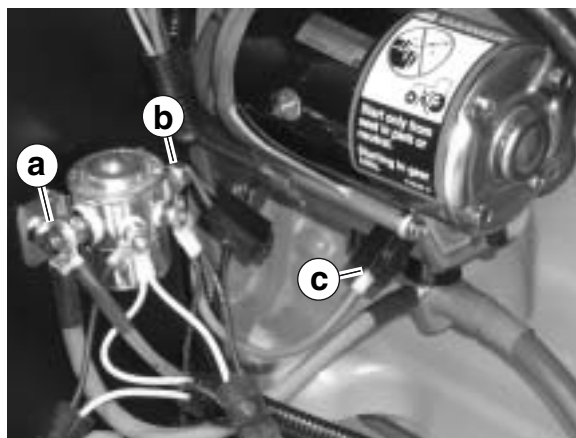

wc\_gr002805

7.18 Engine Cranks But Does Not Start

*Engine Troubleshooting  
Flowchart 2D  
John Deere without ECU*

\* Battery voltage approximately 12V

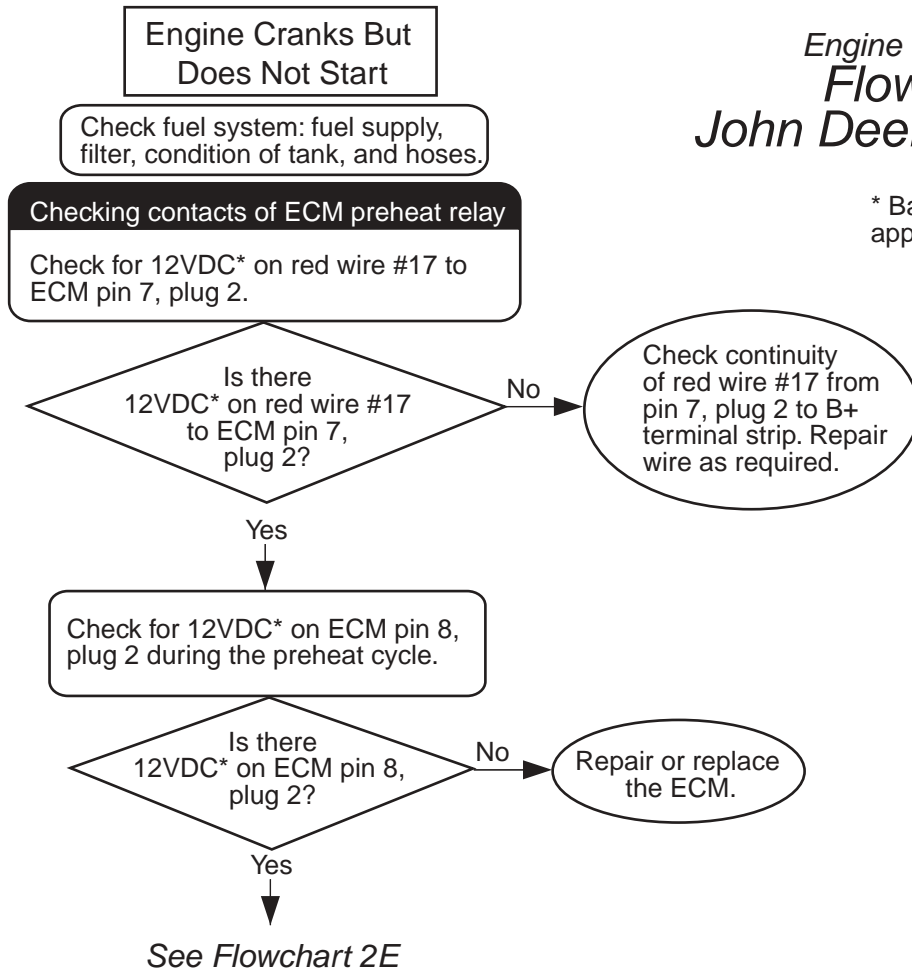

wc\_gr002919

Engine Troubleshooting  
**Flowchart 2E**  
 John Deere without ECU

Engine Cranks but does not Start  
 Continued from Flowchart 2D

\* Battery voltage  
 approximately 12V

**Checking Slave Preheat Relay and Wiring**

With the start switch in the START position, check for 12VDC\* on gray wire #65 at terminal 86 of the slave preheat relay during the preheat cycle.

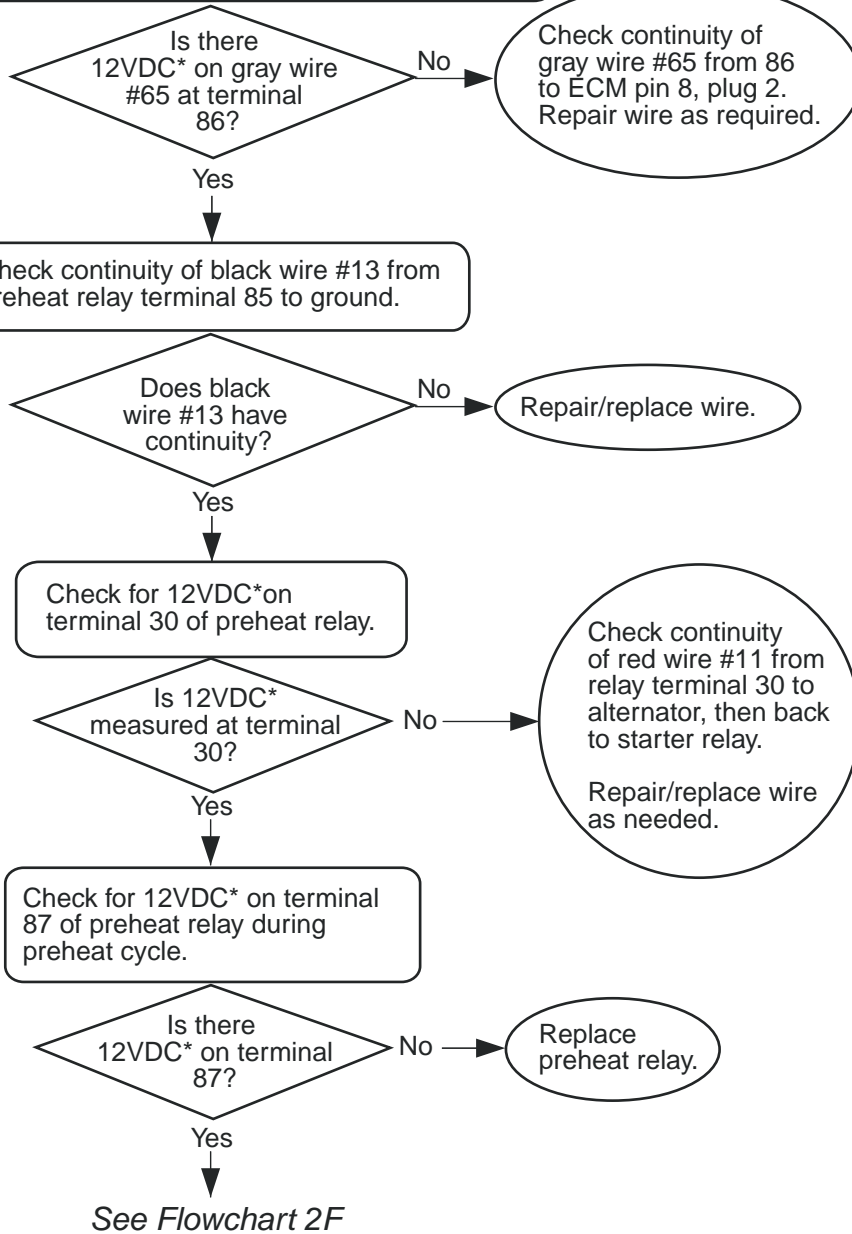

wc\_gr002832

Engine Cranks but does not Start  
Continued from Flowchart 2E

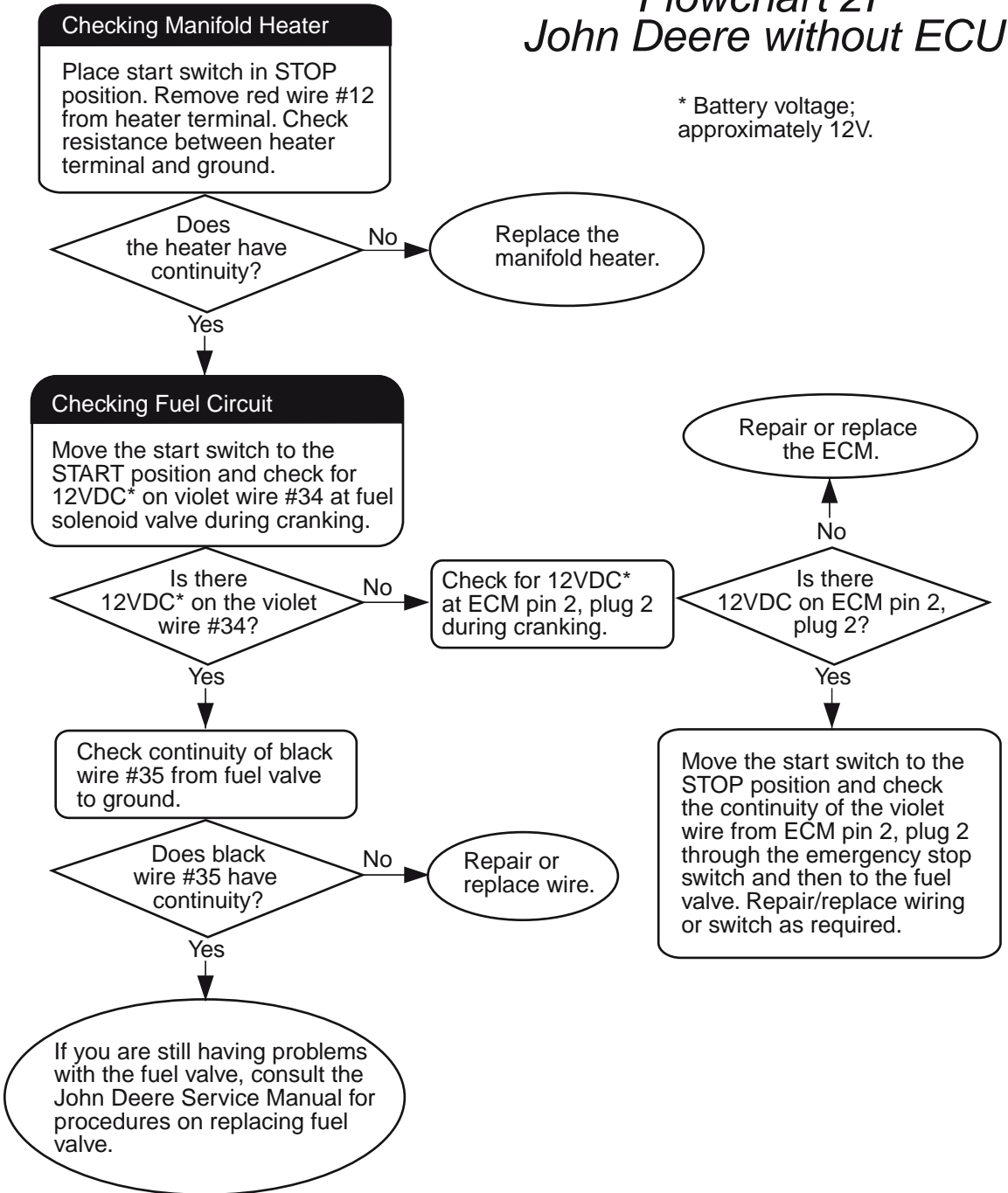

\* Battery voltage; approximately 12V.

wc\_gr002921

## 7.19 Checking Contacts of ECM Preheat Relay

See Graphic: *wc\_gr002928*

The ECM includes an onboard preheat relay **(a)** which is located on the lower board, behind the crank and fuel relays. To test the function of its contacts carry out the following procedure:

- 7.19.1 Probe ECM pin 7, plug 2 **(b)** at red wire #17 for 12VDC (battery voltage approximately 12V). Measure between red wire #17 to pin 7, plug 2 and ground.
- If 12VDC is not measured, check the continuity of red wire #17 from pin 7, plug 2 to the B+ terminal strip. Repair or replace the wire as required.
  - If 12VDC is measured, continue.
- 7.19.2 Place the start switch in the START/RUN position and probe ECM pin 8, plug 2 at gray wire #65 for 12VDC. Measure between gray wire #65 and ground during the preheat cycle.
- If 12VDC is measured, continue by checking the slave preheat relay. See section *Checking Slave Preheat Relay and Wiring*.
  - If 12VDC is not measured, the ECM may be malfunctioning. Call Wacker Service. Repair or replace the ECM.

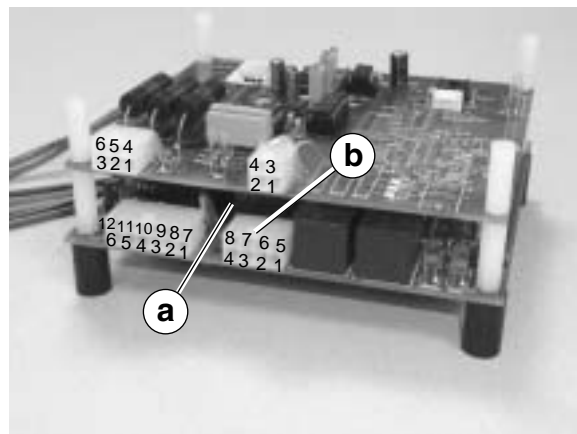

*wc\_gr002928*

## 7.20 Checking Slave Preheat Relay and Wiring

See Graphic: *wc\_gr002827* and *wc\_gr002807*

The slave preheat relay (14) **(a)** is located inside the engine compartment. To check the slave preheat relay, carry out the following procedures:

- 7.20.1 Check power to the coil of the slave preheat relay by measuring voltage (battery voltage approximately 12V) between terminal 86 and ground during the preheat cycle.
  - If 12VDC is not measured, check the continuity of gray wire #65 between terminal 86 and ECM pin 8, plug 2. Repair/replace wire as necessary.
  - If 12VDC is measured, the coil is receiving power; continue.
- 7.20.2 Check condition of the ground wire to the coil by checking continuity of the black wire #13 from terminal 85 of the relay to ground. Repair/replace the wire as necessary.
- 7.20.3 Check power to be switched by measuring voltage between terminal 30 and ground.
  - If 12VDC is not measured, check continuity of the red wire #11 from terminal 30 to B+ on the alternator. Repair or replace the wire as needed.
  - If 12VDC is measured, continue.
- 7.20.4 Check function of the contacts of the relay by measuring voltage between terminal 87 and ground during the preheat cycle.
  - If 12VDC is not measured, replace the slave preheat relay.
  - If 12VDC is measured, the slave preheat relay is functioning.

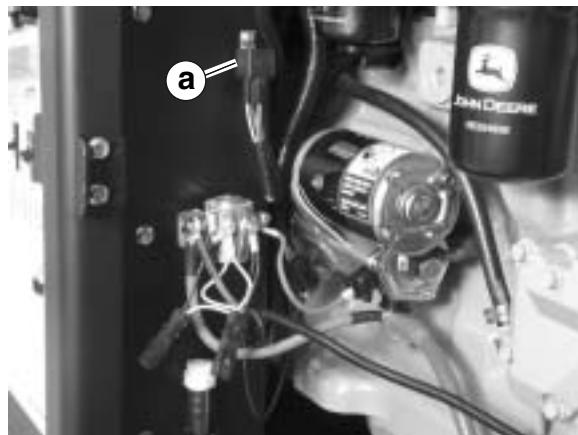

wc\_gr002807

## 7.21 Checking Manifold Heater

See Graphic: *wc\_gr002808*

The manifold heater (**e**) is located in line with the intake air supply.

7.21.1 Disconnect red wire #12 (**c**) from the manifold heater. Check the continuity of red wire #12 between the manifold heater and terminal 87 of the slave preheat relay. Repair/replace the wire as needed.

7.21.2 With red wire #12 disconnected, check the resistance of the manifold heater element by measuring between the heater terminal and the base of the manifold heater.

- If the manifold heater element is open (OL) or has no resistance (0 Ohms), replace it.
- If the manifold heater element has resistance, further test its function by energizing it.

7.21.3 Loosen the hose clamp (**a**) and remove the air hose (**b**) from the coupling.

Optional: Remove bolts (**d**) which secure the manifold heater to the manifold and remove the manifold heater (**e**).



7.21.4 Burn hazard. The heater can reach temperatures up to 1000°F (538°C). Do not touch the element of the manifold heater. Be extremely careful when testing the manifold heater.

With the manifold heater base grounded, apply 12VDC to the manifold heater (at the terminal) for 10 seconds.

- If the manifold heater does not heat (glow) when 12VDC is applied, replace it.
- If the manifold heater glows, it is functioning.

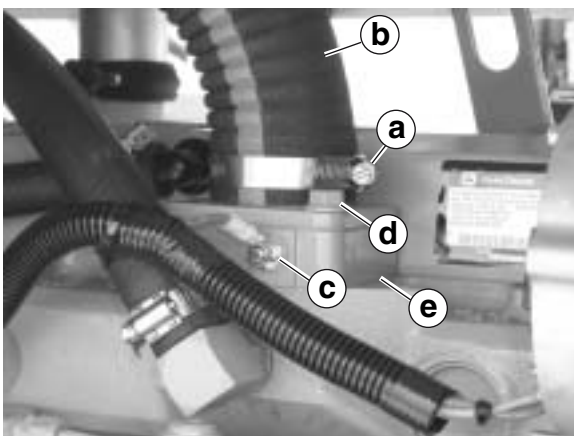

*wc\_gr002808*

## 7.22 Checking Fuel Circuit

See Graphic: *wc\_gr002827* and *wc\_gr002809*

The fuel solenoid valve (22) **(b)** is located inside, near the top of the injection pump. When it is energized, fuel flows to the injection nozzles; when de-energized, fuel flow ceases and the engine stops quickly. There is a single violet wire which supplies power to the fuel solenoid valve. The wire runs from ECM pin 2, plug 2 **(e)** to the emergency stop switch (8) **(f)** and then to the fuel solenoid valve.

- 7.22.1 Place the start switch in the START/RUN position and check that the fuel LED **(a)** is lit during the cranking period.
  - If the fuel LED does not light, see section *Checking Power to ECM and Function of Start Switch*.
  - If the fuel LED does light, continue.
- 7.22.2 Remove violet wire #34 **(d)** at the fuel solenoid valve and check for 12VDC (battery voltage approximately 12V) between it and ground. Also check continuity of the fuel solenoid valve ground wire #35 **(c)**.
  - If 12VDC is present at violet wire #34 and the ground wire is OK, then there is a problem with the fuel solenoid valve. Consult the John Deere engine repair manual for checking and/or replacing the fuel solenoid valve.
  - If 12VDC is not present at violet wire #34, continue.
- 7.22.3 Check for 12VDC between violet wire #64 at the emergency stop switch and ground.
  - If 12VDC is not measured, check the continuity of violet wire #64. If the wire has continuity, it should be receiving power. Probe ECM pin 2, plug 2 for 12VDC. Repair or replace the ECM if 12VDC is not present at ECM pin 2, plug 2.
  - If 12VDC is measured, continue.
- 7.22.4 Move the start switch to the STOP position and check the continuity of violet wire #34 from the emergency stop switch to the fuel solenoid valve.
  - If the wire does not have continuity, repair or replace it.
  - If the wire has continuity, continue.
- 7.22.5 Check the function of the emergency stop switch. Repair/replace the emergency stop switch as needed.

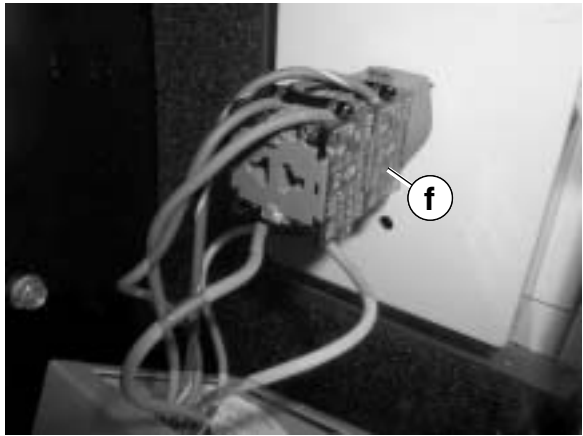
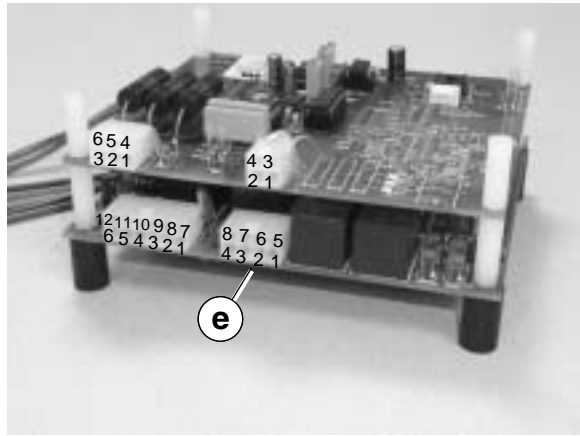
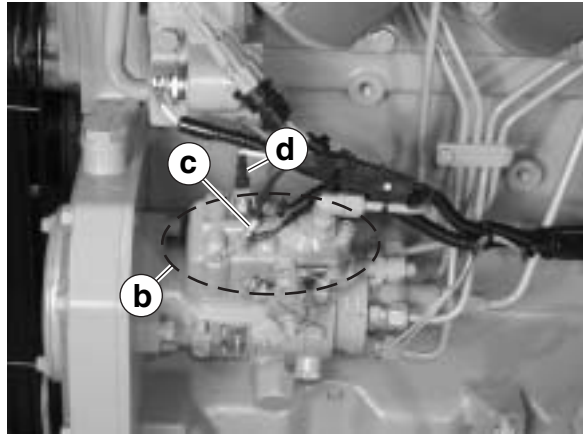
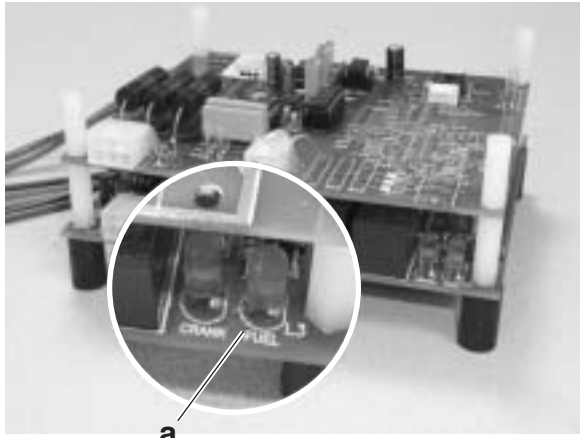

wc\_gr002809

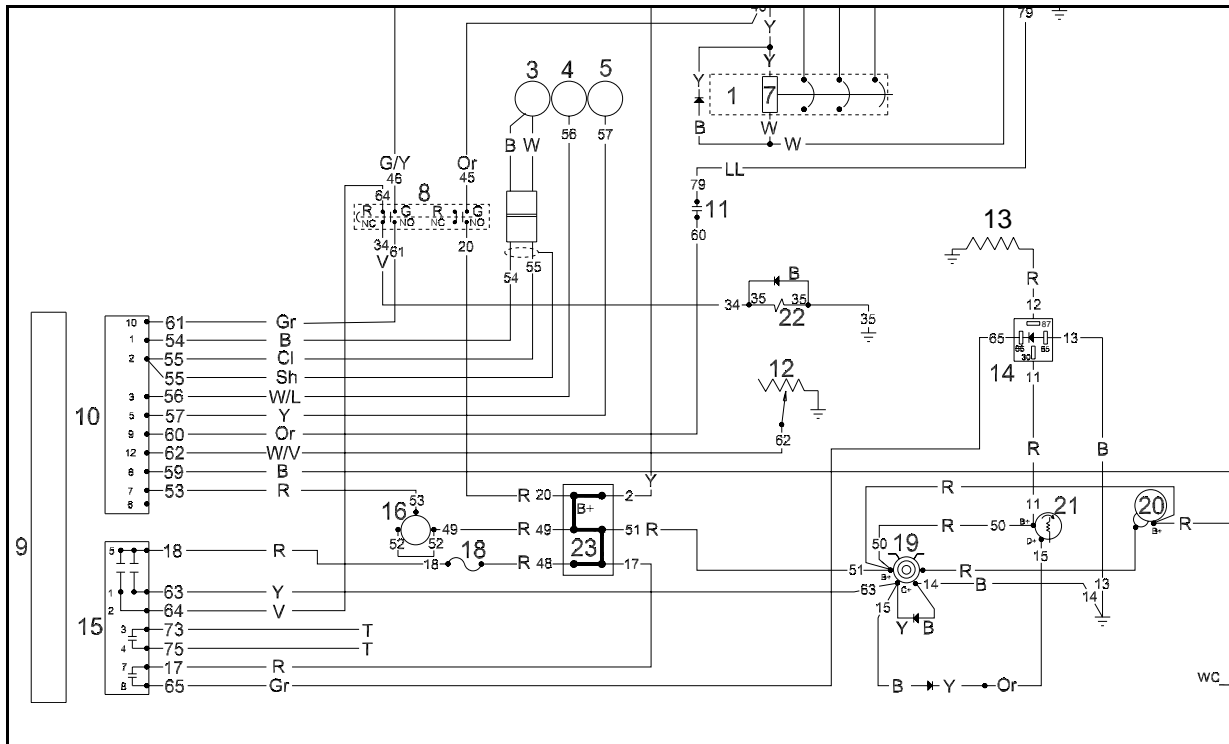

7.23 General Engine Troubleshooting—*John Deere*

Symptom	Problem	Solution
Engine cranks but will not start	Exhaust restricted	Check and correct exhaust restriction.
	Fuel filter plugged or full of water	Replace fuel filter or drain water from filter.
	Injection pump not getting fuel or air in fuel system	Check fuel flow at supply pump or bleed fuel system.
	Faulty injection pump or nozzles	Consult authorized diesel repair shop for repair or replacement.
	No fuel	Check fuel tank and hoses.
Engine hard to start or will not start	Engine starting under load	Place all circuit breakers in OFF positions.
	No fuel	Check fuel tank and hoses.
	Air in fuel line	Bleed fuel line.
	Cold weather	Use cold weather starting aids.
	Crankcase oil too heavy	Use oil of proper viscosity.
	Improper fuel type	Use proper fuel type for operating conditions.
	Water, dirt or air in fuel system	Drain, flush, fill, and bleed fuel system.
	Clogged fuel filter	Replace filter element.
	Dirty or faulty injection nozzles	Have authorized service dealer or distributor check injectors.
	Injection pump shut-off not reset	Place start switch in OFF position, then to START.

Symptom	Problem	Solution
Engine knocks	Low engine oil level	Add oil to engine crankcase.
	Injection pump out of time	See authorized service dealer or distributor.
	Low coolant temperature	Remove and check thermostat.
	Engine overheating	See "Engine overheats" symptom in this chart.
Engine runs irregularly or stalls frequently	Low coolant temperature	Remove and check thermostat.
	Clogged fuel filter	Replace fuel filter element.
	Water, dirt, or air in fuel system	Drain, flush, fill, and bleed system.
	Dirty or faulty injection nozzles	Have authorized servicing dealer or engine distributor check injectors.
Lack of power	Engine overloaded	Reduce load.
	Intake air restriction	Service air cleaner.
	Clogged fuel filter	Replace filter elements.
	Improper type of fuel.	Use proper fuel.
	Overheated engine.	See "Engine overheats" symptom in this chart.
	Below normal engine temperature.	Remove and check thermostat.
	Improper valve clearance.	See authorized dealer or distributor.
	Dirty or faulty injection nozzles.	Have authorized service dealer or distributor check injectors.
	Injection pump out of time.	See authorized dealer or distributor.

Symptom	Problem	Solution
	Turbo charger not functioning (Turbocharge engines only).	See authorized dealer or distributor.
	Leaking exhaust manifold gasket.	See authorized dealer or distributor.
	Defective aneroid control line.	See authorized dealer or distributor.
	Restricted fuel hose	Clean or replace fuel hose.
Engine emits white smoke	Improper fuel type	Use proper fuel.
	Low engine temperature	Warm up engine to normal operating temperature.
	Defective thermostat	Remove and check thermostat.
	Defective injection nozzles	See authorized dealer or distributor.
	Engine out of time	See authorized dealer or distributor.
Engine emits black smoke	Improper fuel type	Use proper fuel.
	Clogged or dirty air cleaner	Service air cleaner.
	Engine overloaded	Reduce load.
	Injection nozzles dirty	See authorized dealer or distributor.
	Engine out of time	See authorized dealer or distributor.
	Turbocharger not functioning	See authorized dealer or distributor.

Symptom	Problem	Solution
Engine overheats	Engine overloaded	Reduce load.
	Low coolant level	Fill radiator to proper level. Check radiator and hoses for loose connections and leaks.
	Faulty radiator cap	See authorized dealer or distributor.
	Stretched poly-vee belt or defective belt tensioner	Check automatic belt tensioner and check belts for stretching. Replace belts as required.
	Low engine oil level	Check oil level. Add oil as required.
	Cooling system needs flushing	Flush cooling system.
	Defective thermostat	Remove and check thermostat.
	Defective temperature gauge or sender	Check water temperature with thermometer and replace temperature gauge or sender as required.
	Incorrect grade of fuel	Use correct grade of fuel.

**Notes**

## 8. John Deere Engines with ECU

### 8.1 John Deere Engine Background

The (tier II) John Deere engines with electronic control systems are used on Wacker generator models G 85 (BOM 9305), G 125, and G 160. The electronic control system consists of:

- Engine Control Unit (ECU); the computer which controls fuel, and the ignition system.
- The following sensors: oil pressure, coolant temperature, fuel temperature, manifold air temperature, crank position and speed.
- Fuel pump control solenoid.
- Manifold air heater.

The electronic control system serves as a governor by controlling the fuel to the engine. It does so by controlling the engine's injection pump control valve through a proportional solenoid. In doing so, fuel is delivered according to engine conditions, in precise amounts, and at the precise time in relation to piston position.

The ECU communicates with the Engine Control Module (ECM) mounted to the generator's control panel through a Controller Area Network (CAN). The wiring between the controllers forms a bus (physical electrical interface where many devices share the same electrical connections). Diagnostic tools available from John Deere can plug into the CAN bus to assist in troubleshooting the operation of the engine. The ECM controls the engine up through engine start (cranking). Once started, the ECU controls the running of the engine.

The ECU has diagnostic abilities and shares engine diagnostic information through codes which are displayed on the ECM display screen. These diagnostic codes are referred to as "SPN/FMI" codes: Suspect Parameter Number (SPN) and Failure Mode Identifier (FMI). SPN/FMI codes are conveyed in a two-part code number. The SPN typically contains between two and four digits and is the first number of the code. The FMI contains one or two digits and is the second number of the code. For example, if the ECM displays "SPN/FMI 100.4", The SPN "100" indicates a condition with the engine oil. FMI "4" indicates that the engine oil pressure input voltage is lower than the sensor's specification—a condition associated with a disconnected oil pressure sensor. There are many such SPN/FMI codes. See the John Deere service manual for more information

8.2 Engine Wiring Diagram—John Deere with ECU

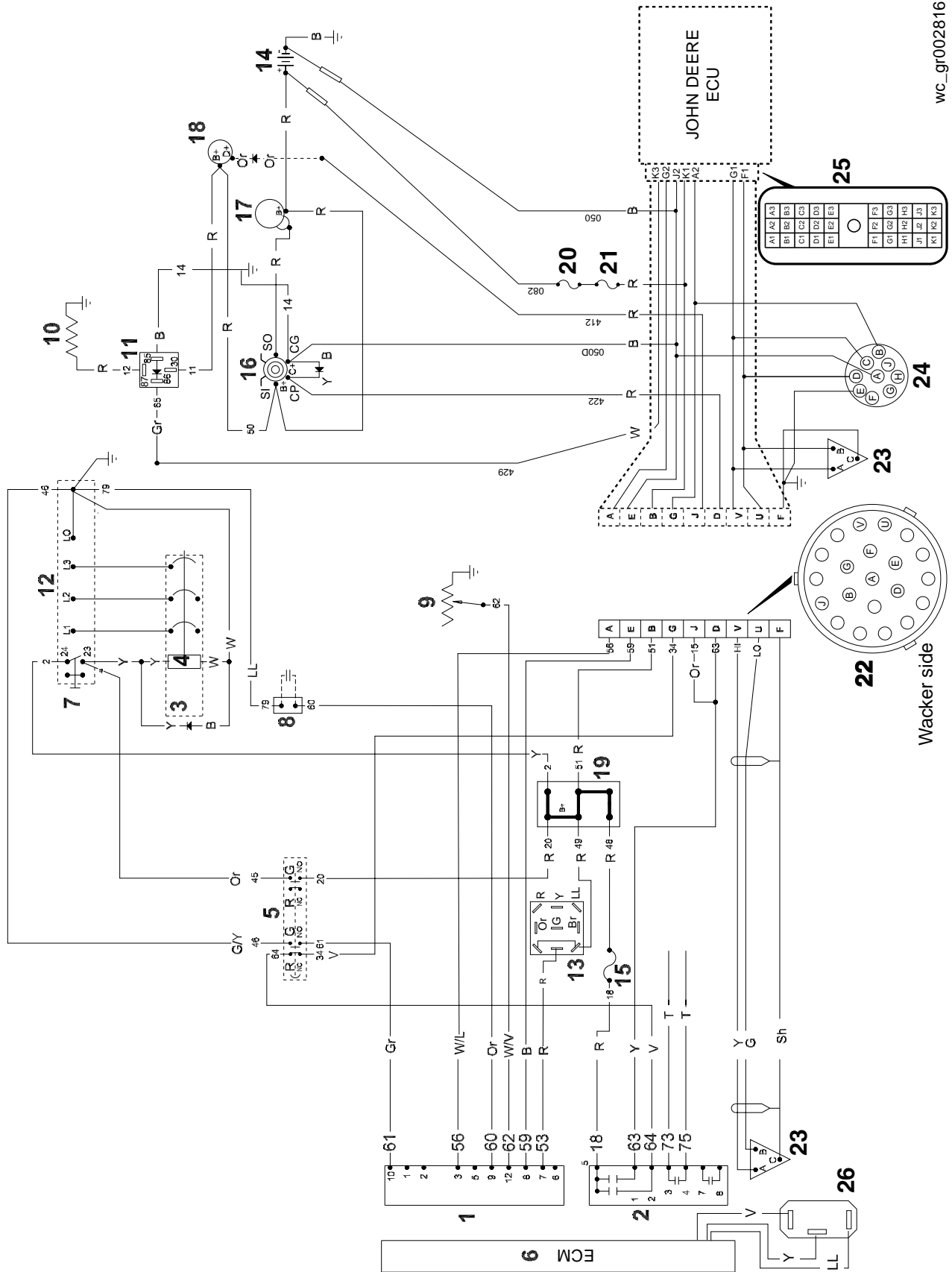

wc\_gr002816

8.3 Engine Wiring Components—*John Deere with ECU*

Ref.	Description	Ref.	Description
1	Plug 1 — engine sender inputs	14	Battery
2	Plug 2 — engine start/run outputs	15	ECM 10A fuse
3	Main circuit breaker (3-phase lugs)	16	Starter relay
4	Shunt trip coil	17	Starter
5	Emergency stop switch	18	Alternator
6	Engine Control Module (ECM)	19	B+ Terminal block
7	Safety interlock switch	20	System 10A fuse
8	Remote start terminals	21	System 30A fuse
9	Fuel level sender	22	Harness connector
10	Intake heater	23	CAN bus connector
11	Slave preheat relay	24	Diagnostic connector
12	Mechanical lugs (3 phase)	25	ECU harness connector
13	Start switch	26	Hour meter switch

ECM Plug 1 Wires			ECM Plug 2 Wires		
Pin	Wire	Description	Pin	Wire	Description
10	Gr/61	Emergency stop	5	R/18	Battery + (for relays)
3	W/L/56	Oil pressure sender	1	Y/63	Crank (12V output)
9	Or/60	Remote start	2	V/64	Run/Fuel (12V output)
12	W/V/62	Fuel level	3	73	Remote annunciator (NA)
8	B/59	Battery –	4	75	Remote annunciator (NA)
7	R/53	Battery + (for ECM board)	-	-	---

Wire Colors							
B	Black	R	Red	Y	Yellow	Or	Orange
G	Green	T	Tan	Br	Brown	Pr	Purple
L	Blue	V	Violet	Cl	Clear	Sh	Shield
P	Pink	W	White	Gr	Gray	LL	Light blue

8.4 ECU Wiring Diagram

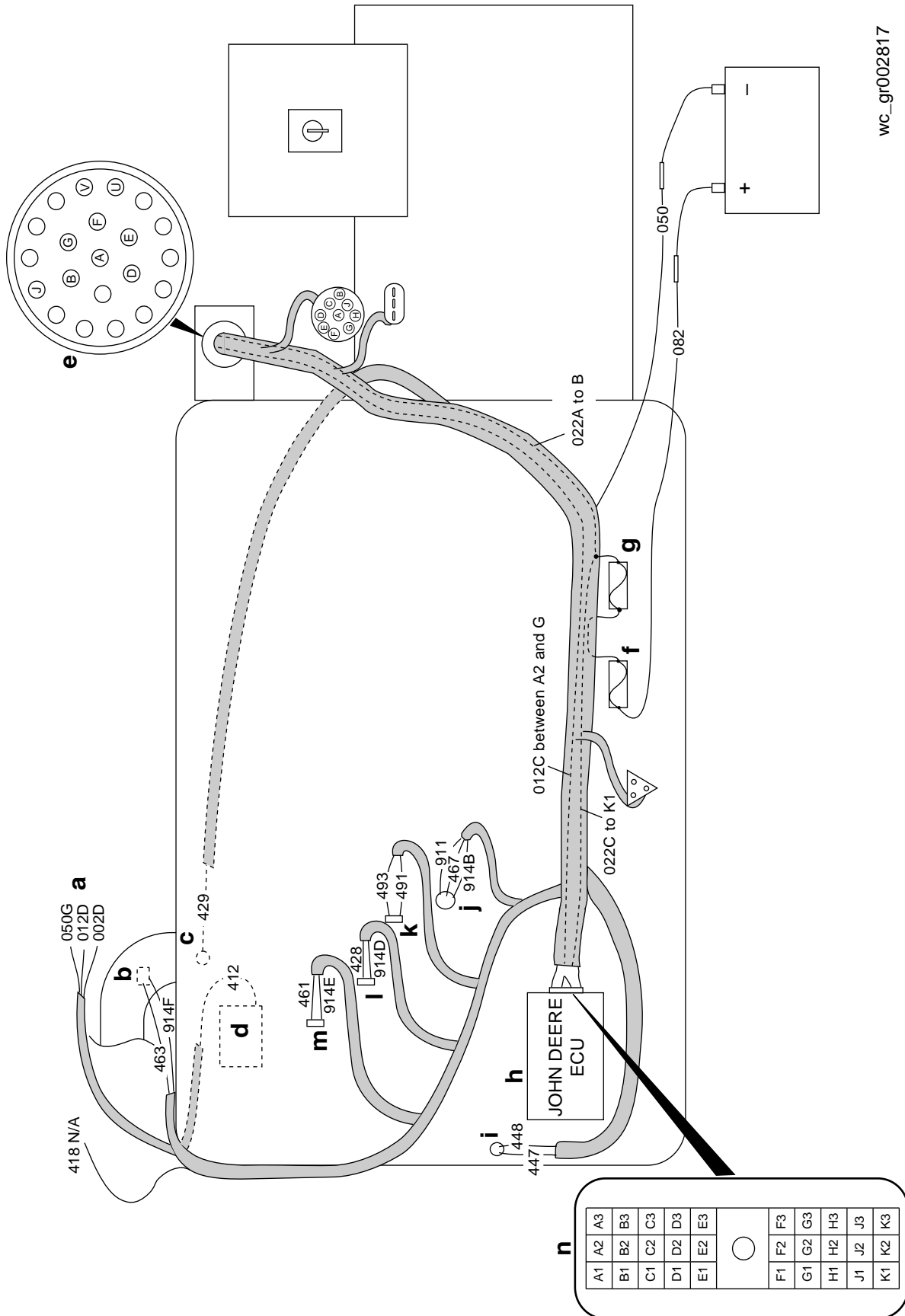

wc\_gr002817

**8.5 ECU Harness Connector**

See Graphic: *wc\_gr002817*

Ref.	Wire Color/#	Destination	Ref.	Wire Color/#	Destination
A1	---	---	F1	Green/905	CAN bus
A2	Red/012C	Harness Connector (HC) terminal G	F2	---	---
A3	Orange/493	Fuel control solenoid	F3	Violet/467	Oil pressure sensor
B1	Brown/461	Colant temp sensor	G1	Yellow/904	CAN bus
B2	Violet/447	Engine crank sensor	G2	W/L / 474	ECM
B3	Gray/918	HC terminal N (N/A)	G3	Orange/473	HC terminal H (N/A)
C1	Violet/947	HC terminal R (N/A)	H1	---	---
C2	---	---	H2	---	---
C3	Gray/428	Fuel temp sensor	H3	---	---
D1	Orange/463	Manifold Air Temp (MAT) sensor	J1	Gray/418	N/A
D2	Gray/448	Engine crank sensor	J2	Black/050C	Ground
D3	Yellow/914C	Sensor return	J3	---	---
E1	---	---	K1	Red/022	10A fuse
E2	Brown/911C	Sensor excitation 5V	K2	Brown/491	Fuel control solenoid
E3	White/439	HC terminal K (N/A)	K3	White/429	Air heater relay

**8.6 Sensors and Components**

See Graphic: *wc\_gr002817*

a	To fuel heater (N/A)	h	ECU
b	MAT sensor	i	Crank position sensor
c	Intake manifold heater	j	Oil pressure sensor
d	Alternator	k	Fuel pump control solenoid
e	Harness connector	l	Fuel temperature sensor
f	30A fuse	m	Engine coolant temperature sensor
g	10A fuse	n	ECU harness connector

8.7 Locations of Engine Electrical Components

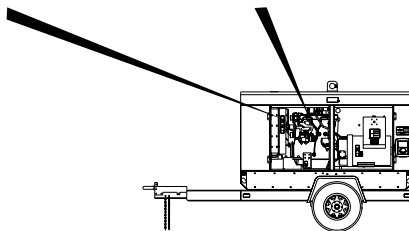
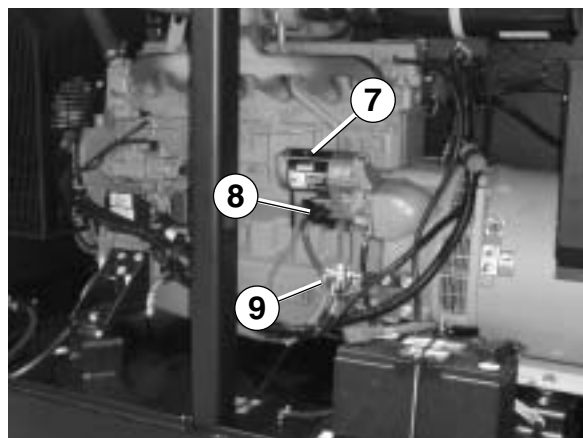
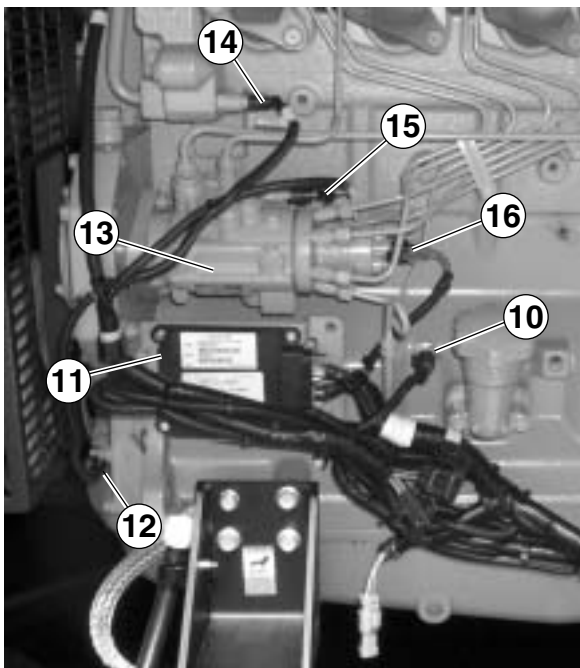
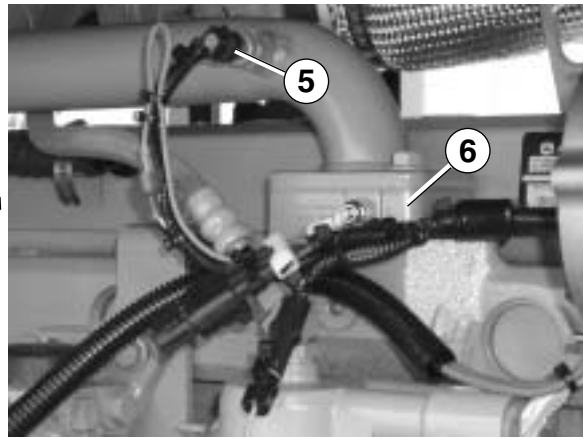
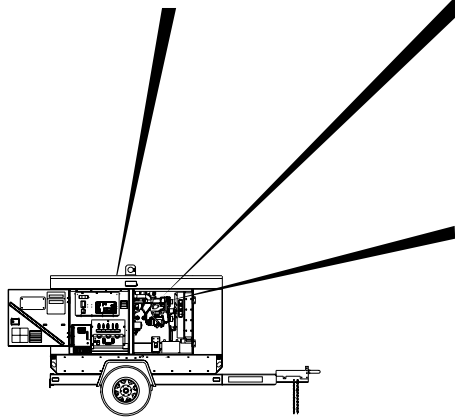
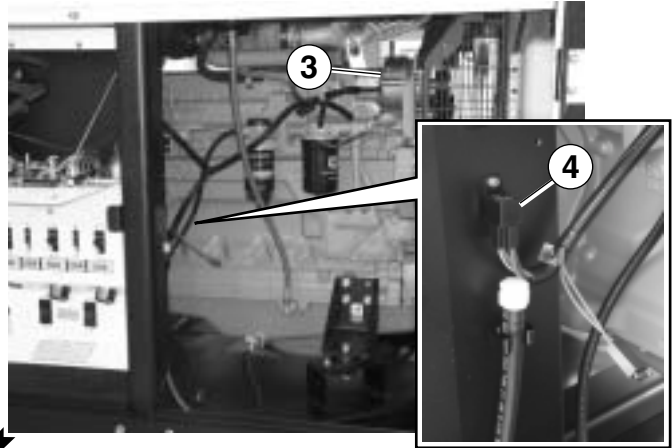
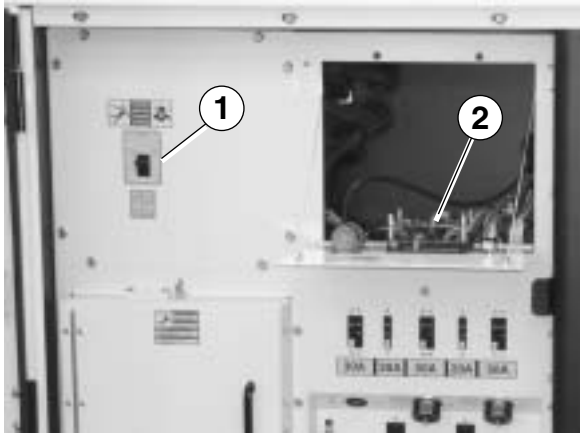

wc\_gr002812

## 8.8 Engine Electrical Components

See Graphic: *wc\_gr002812*

Ref.	Component	Ref.	Component
1	Main circuit breaker	9	Starter relay
2	Engine Control Module (ECM)	10	Oil pressure sensor
3	Alternator	11	Engine Control Unit (ECU)
4	Slave preheat relay	12	Crank position sensor
5	Manifold air temperature sensor	13	Fuel pump assembly
6	Manifold heater	14	Coolant temperature sensor
7	Starter motor	15	Fuel temperature sensor
8	Starter motor solenoid	16	Fuel pump control solenoid

## 8.9 Troubleshooting Flowcharts

The troubleshooting flowcharts are designed to take you through the process of determining the source of a problem with engine starting or machine operation. Many of the tests involve live voltages and therefore should only be attempted by qualified personnel. Detailed procedures for carrying out the tests are included in this manual. All highlighted text within the flowcharts have matching sections in this manual.

8.10 Engine Troubleshooting—John Deere with ECU

Engine Troubleshooting  
Flowchart 2G  
John Deere with ECU

\* Battery voltage approximately 12V

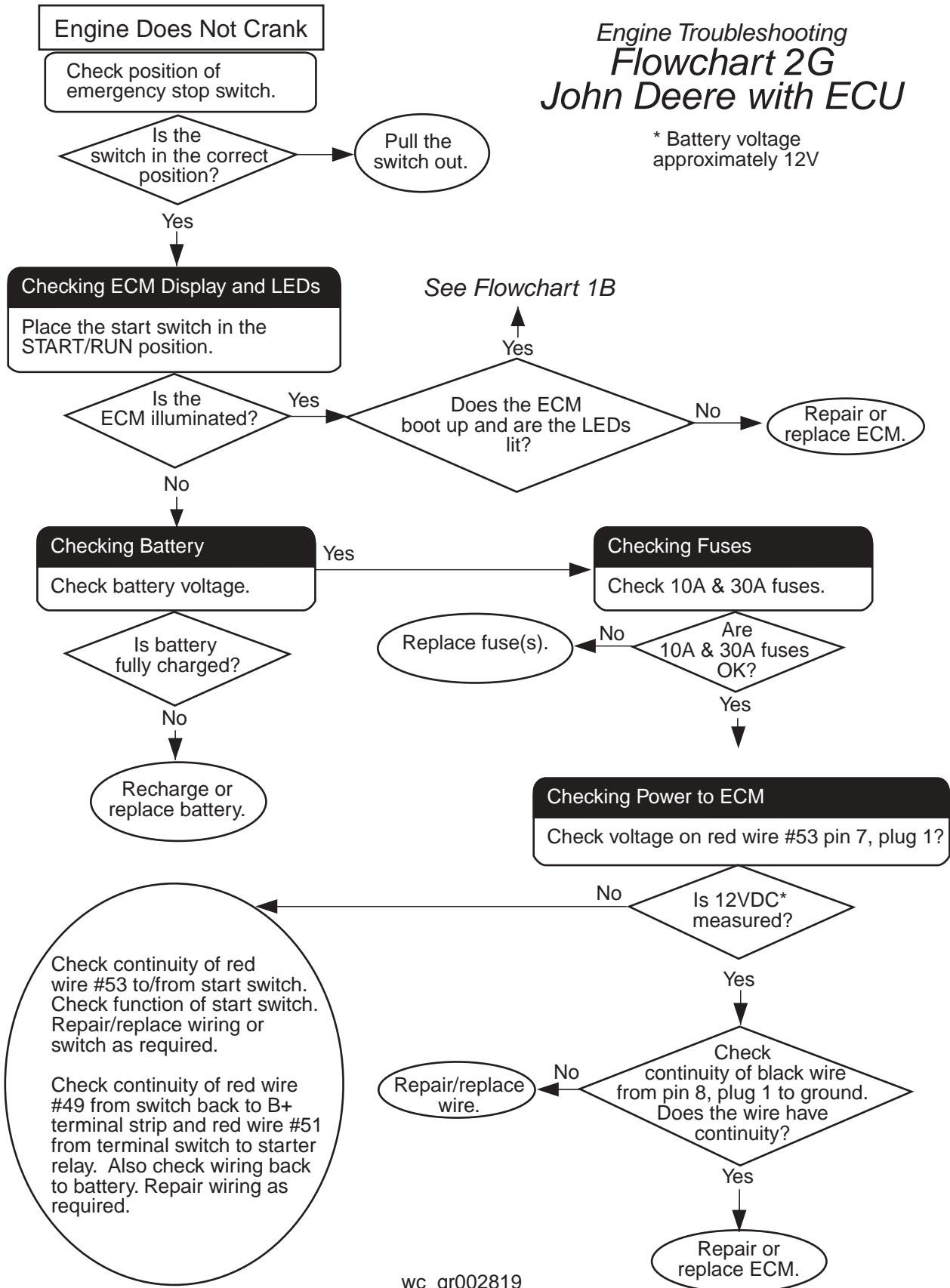

wc\_gr002819

Engine Troubleshooting  
**Flowchart 2H**  
 John Deere with ECU

Engine does not Crank  
 Continued from Flowchart 2G

\* Battery voltage approximately 12V

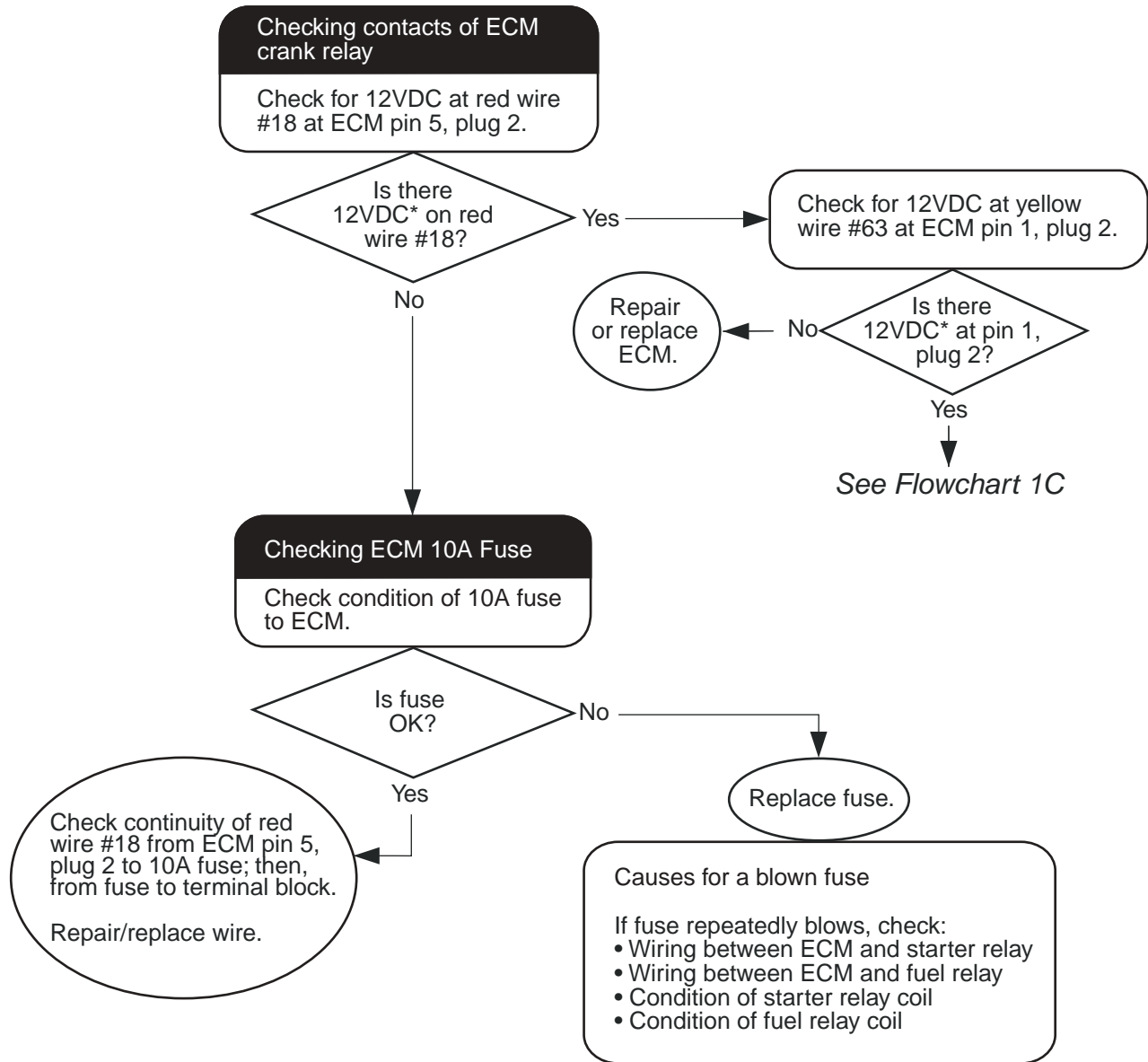

wc\_gr002823

Engine Troubleshooting  
**Flowchart 21**  
 John Deere with ECU

Engine does not Crank  
 Continued from Flowchart 2H

\* Battery voltage  
 approximately 12V

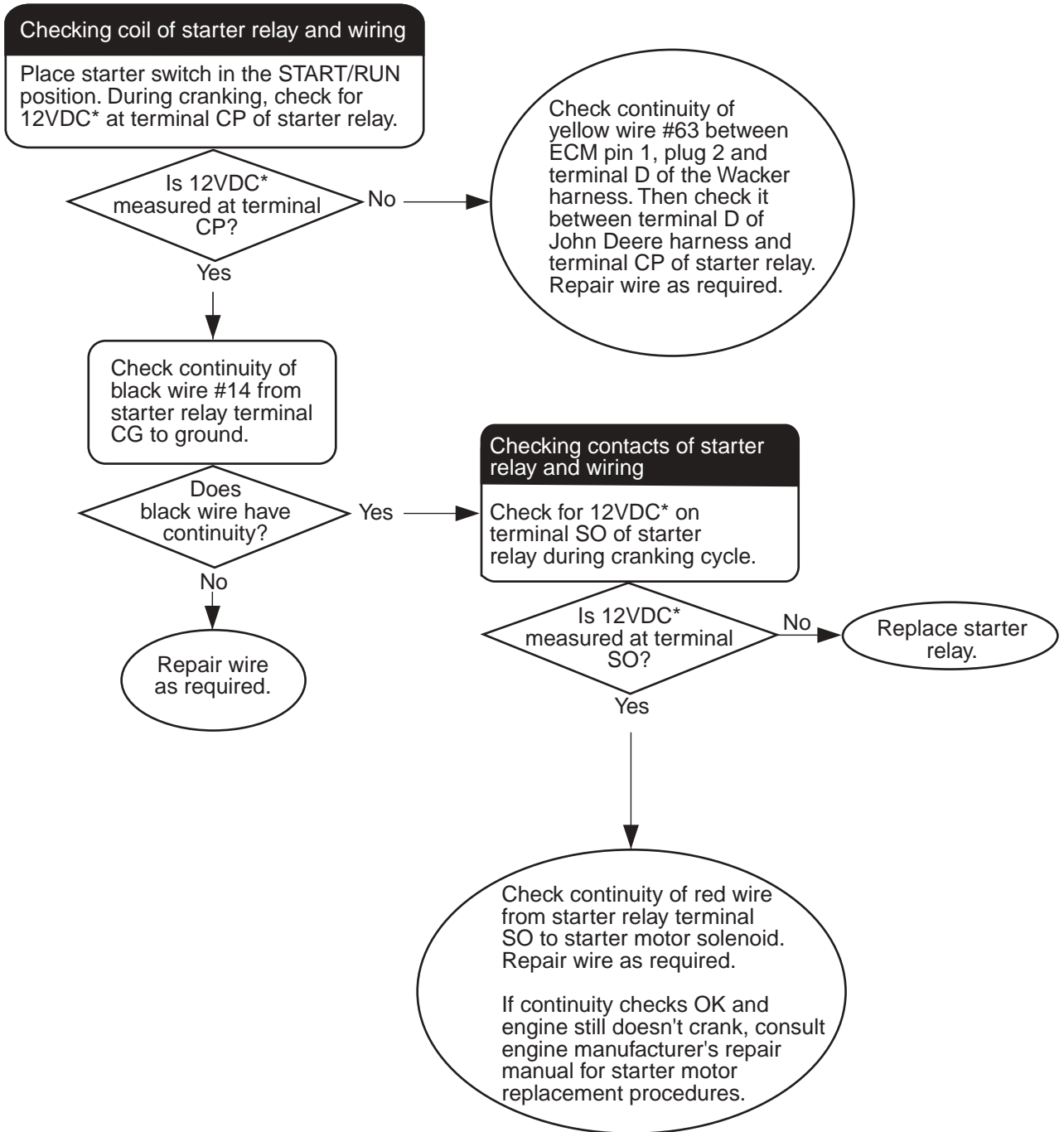

wc\_gr002824

## 8.11 Checking Wiring Continuity

When checking the continuity of a wire, use the Ohms scale on your checking instrument (multimeter). A reading of less than one Ohm means the wire has continuity and should be OK. A reading over one Ohm usually means that the wire or connectors are corroded and should be repaired or replaced. A reading of "OL" or "OPEN" means the wire is broken and there is no continuity. In such cases, repair or replace the wire.

## 8.12 Probing Plugs and Pins

See Graphic: *wc\_gr002926*

To measure the voltage at an ECM pin, attach an appropriate extension **(a)** to the positive probe on your multimeter. Slide the positive probe into the plug along the wire of the pin to be tested. Use care when testing this way so you don't damage the wire, plug, or ECM. Find a suitable ground on the machine's frame for the negative probe **(b)** of your multimeter.

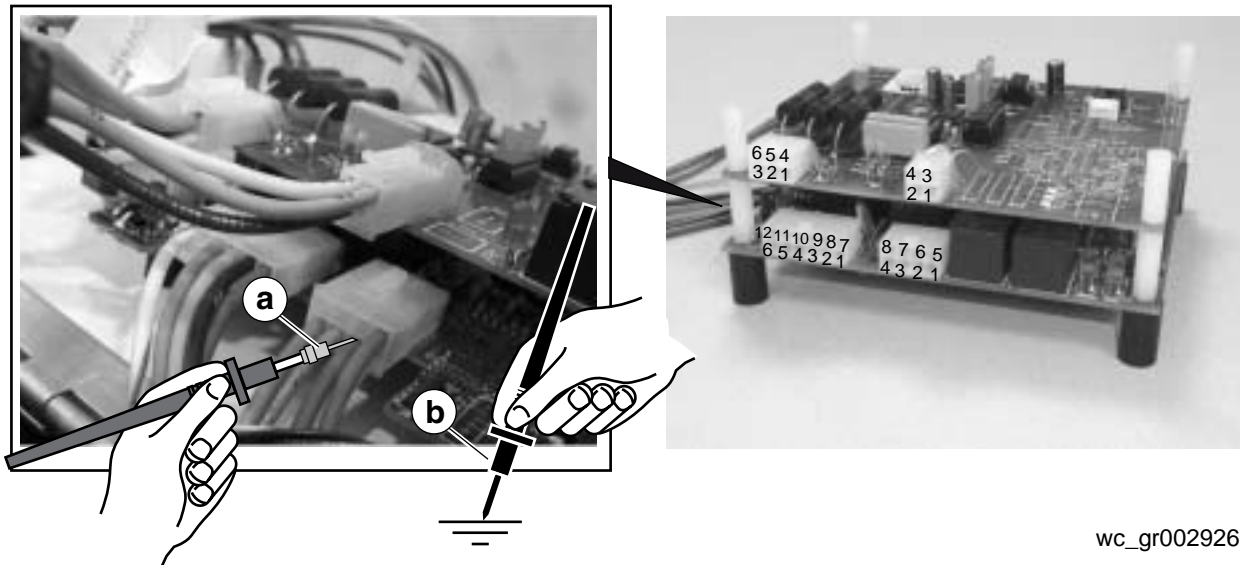

wc\_gr002926

### 8.13 Checking ECM Display and LEDs

See Graphic: wc\_gr0002813

- 8.13.1 Remove the three screws **(a)** securing the control panel and open the panel.
- 8.13.2 Check general condition of all ECM connectors (plugs) and wiring. Look for burn marks, melting, and signs of damage; repair or replace as necessary.
- 8.13.3 Place the start switch in the "START/RUN" position.
  - If the ECM display does not illuminate, check the battery and the system's 10A and 30A fuses.
  - If the ECM display does illuminate, continue.
- 8.13.4 Place the start switch in the "START/RUN" position. Check that the display reads: "Initializing..."; "Time to Service"; "Cranking 1 of 3"; and that the red LEDs **(b)** located on the edge of the ECM circuit board illuminate when the display reads "Cranking \_\_ of 3".

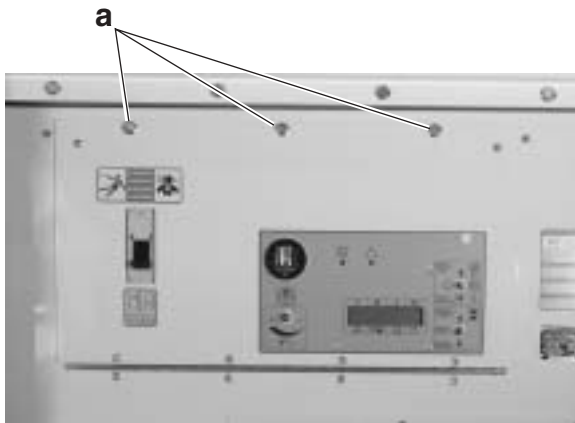

wc\_gr0002813

## 8.14 Checking System 10A & 30A Fuses

See Graphic: *wc\_gr002820*

There are two fuses in the wiring from the battery that protect the electrical system. Both fuses are located near the ECU; the 30A fuse **(a)** (21) is the first, the 10A fuse **(b)** (20) the second.

To check the fuses, remove the connector cover which protects the fuse. Replace the fuse if it is blown. If the fuse repeatedly blows, it is a sign of a short in the wiring. Repair or replace the wiring as necessary.

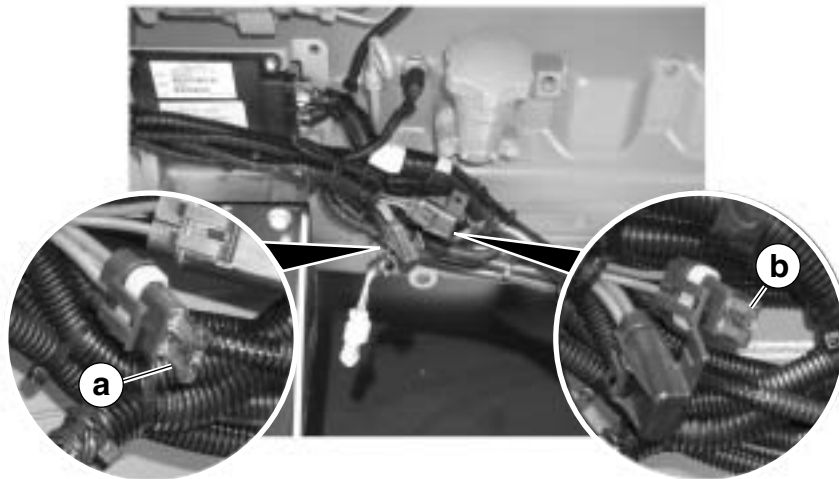

*wc\_gr002820*

## 8.15 Checking Battery

The ECM display may or may not be blank when the battery voltage is less than 12V. During such a condition, the battery may be charged enough to light the display, but not enough to fully crank the starter.

- 8.15.1 Check that the battery cable connections are tight.
- 8.15.2 Check the battery terminals for corrosion. Clean the terminals if necessary. Corroded terminals and loose connections will result in hard starting and insufficient battery charge.
- 8.15.3 Check the battery for proper voltage: 11–13V.
- 8.15.4 Charge or replace the battery if needed.

**CAUTION:** Do not jump-start the machine using a battery or charging system with greater than 12–14V. Damage to the machine's electrical system will occur.

**CAUTION:** Do not jump start the machine without a battery connected. Damage to the machine's electrical system will occur.

## 8.16 Checking Power to ECM and Start Switch

See Graphic: *wc\_gr002816 and wc\_gr002814*

- 8.16.1 Disconnect plug 1 from the ECM. Place the start switch (13) in the START/RUN position and check for 12VDC (battery voltage approximately 12V) between red wire #53 at pin 7, plug 1 and ground.
- If 12VDC is measured, the ECM is receiving power.
  - If 12VDC is not measured, continue.
- 8.16.2 Place the start switch in the OFF position and check the continuity of red wire #53 from pin 7, plug 1 to the start switch.
- If the wire does not have continuity, repair or replace it.
  - If the wire has continuity, continue.
- 8.16.3 Check the start switch. Remove the red wires **(a)** and check the terminals for continuity—outer terminals to center (only one pair of terminals per switch position.)
- If the switch does not have continuity, repair or replace it.
  - If the switch has continuity, continue.
- 8.16.4 Check the continuity of red wire #49 between the start switch and the terminal block (19) **(b)**.
- If the wire does not have continuity, repair or replace it.
  - If the wire has continuity, continue.
- 8.16.5 Separate the John Deere engine harness from the Wacker harness at connector **(c)**. Check the continuity of red wire #51 between the terminal block and terminal **B** of the Wacker harness.
- If the wire does not have continuity, repair or replace it.
  - If the wire has continuity, continue.
- 8.16.6 Check the continuity of red wire #022C between terminal **B** of the John Deere engine harness and terminal K1 of the ECU harness connector **(d)**.
- If the wire does not have continuity, repair or replace it.
  - If the wire has continuity, continue.
- 8.16.7 Check the continuity of black wire #59 from pin 8, plug 1 through terminal **E** of each harness (John Deere and Wacker) to ground. Repair/replace wire as required.

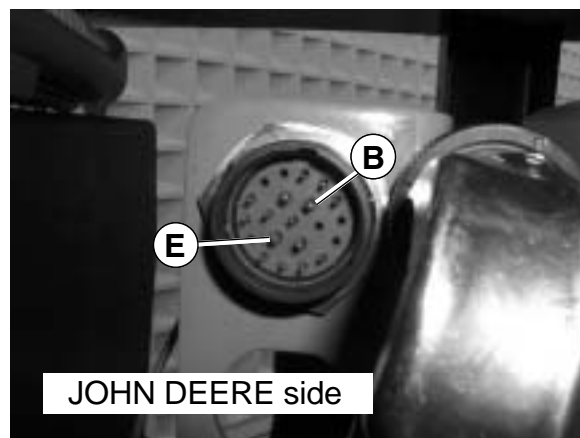
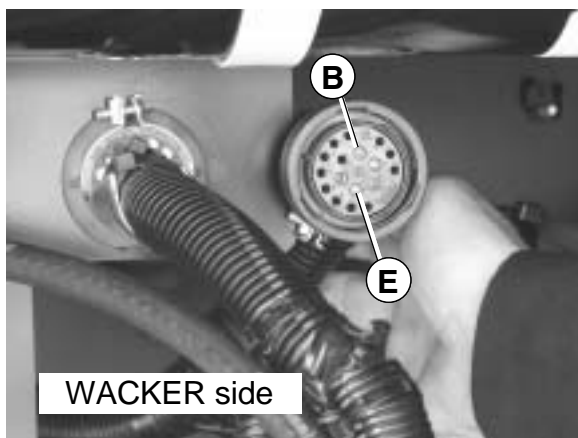
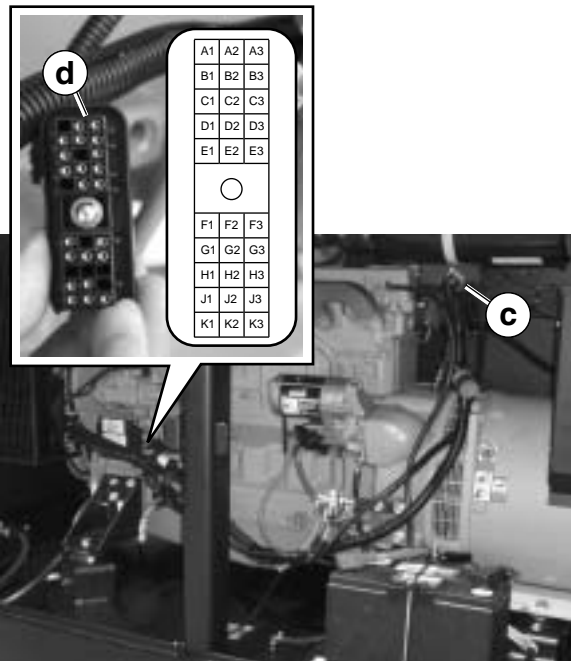
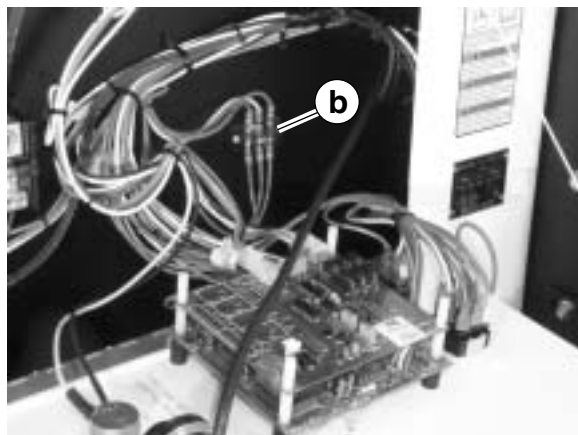
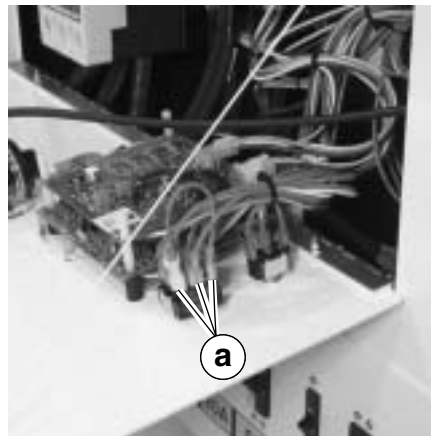
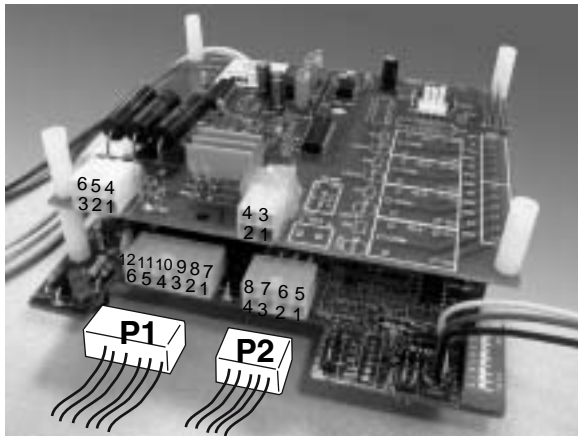

wc\_gr002814

## 8.17 Checking Contacts of ECM Crank Relay

See Graphic: *wc\_gr002816* and *wc\_gr002830*

When the start switch is placed in the START/RUN position, the ECM crank relay **(c)** energizes. The ECM crank relay supplies 12VDC through yellow wire #63 to energize the starter relay (14).

- 8.17.1 Check for 12VDC (battery voltage approximately 12V) between red wire #18 at pin 5, plug 2 and ground.
- If 12VDC is measured, the ECM relay contact circuit is receiving power. Go to step 5.
  - If 12VDC is not measured, continue.
- 8.17.2 Check the ECM 10A fuse (18)**(a)**.
- If the fuse is blown, see section *Checking ECM 10A Fuse*.
  - If the fuse is OK, continue.
- 8.17.3 Check continuity of red wire #18 from ECM pin 5, plug 2 to the 10A fuse.
- If the wire does not have continuity, repair or replace it.
  - If the wire has continuity, continue.
- 8.17.4 Check the continuity of red wire #48 from the 10A fuse to the B+ terminal strip **(b)**.
- If the wire does not have continuity, repair or replace it.
  - If the wire has continuity, continue.
- 8.17.5 Place the start switch in the START/RUN position and probe yellow wire #63 at pin 1, plug 2 for 12VDC during the cranking cycle.
- If 12VDC is measured, the ECM crank relay contact circuit is functioning.
  - If 12VDC is not measured, the ECM is malfunctioning; repair or replace it. Call Wacker Service.

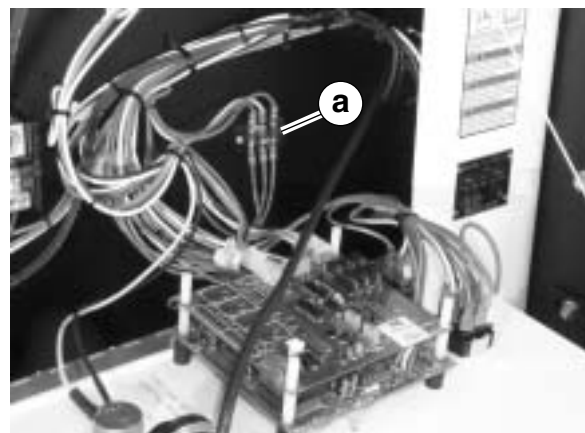
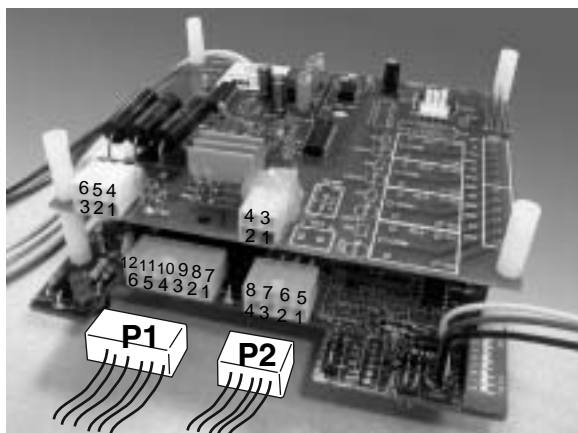

*wc\_gr002830*

## 8.18 Checking ECM 10A Fuse

See Graphic: *wc\_gr002802*

The 10A fuse is found in the control compartment on G25 models **(a)**. It is found in the engine compartment on all other models **(b)**. There is 12VDC fed through this fuse to the ECM fuel and crank relay contacts via ECM pin 5, plug 2. If the fuse repeatedly blows, it is a sign that there is a short in the wires to/from the ECM, a diode is faulty, or the fuel or starter relay is shorted.

8.18.1 Check the 10A fuse. If it is blown, check:

- The condition of the wiring to/from the fuse. Repair or replace the wiring as needed.
- On Isuzu-powered generators, check the condition of the starter relay coil (see section *Checking Coil of Starter Relay and Wiring*); condition of the fuel relay coil (see section *Checking Coil of Fuel Pump Relay*). Also check for failed diodes. See section *Checking Diode Across Relay/Solenoid Coil*.
- On Deere-powered generators, check the condition of the starter relay coil (see section *Checking Coil of Starter Relay and Wiring*); and the condition of the fuel solenoid (see section *Checking Fuel Solenoid*). Also check for failed diodes. See section *Checking Diode Across Relay/Solenoid Coil*.

8.18.2 Once the wiring, relay/solenoid coils, and diodes check OK, replace the 10A fuse.

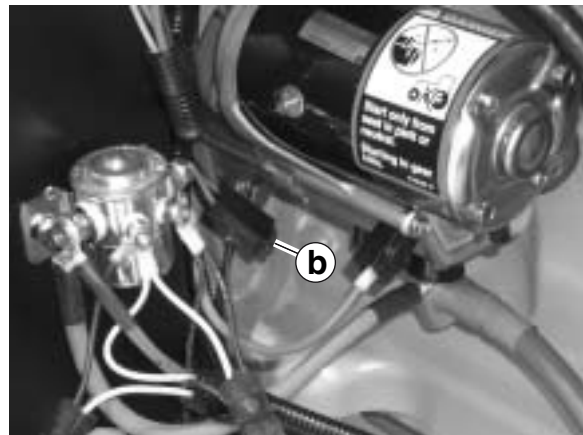
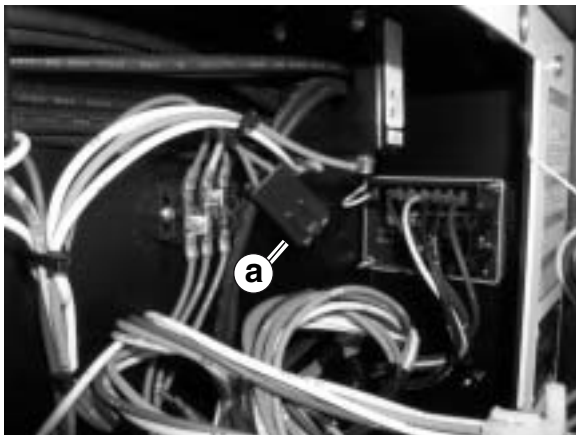

*wc\_gr002802*

## 8.19 Checking Relay Coil Diodes

See Graphic: *wc\_gr002803*

The glow plug relay **(a)** and the fuel solenoid **(b)** on Isuzu powered generators, and the starter relay **(c)** (and fuel solenoid **(d)** on John Deere engines without the Engine Control Unit (ECU)), all have a diode **(e)** similar to the one pictured connected across the coil. The diodes are encapsulated in rubber. They are installed in the circuit to redirect a voltage spike to ground if one should occur during powering down the relay's coil. In order to check the diode, separate the diode portion from the connector portion.

**Note:** *Replacement diodes come with the connector portion and wiring. It is permissible to remove and discard the replacement connector portion and insert the replacement diode into the existing connector and wiring.*

- 8.19.1 Using the diode scale on a multimeter, check that the diode conducts in only one direction and not in the other. The meter should read 0.450–0.550V in one direction and “OL” or “OPEN” in the other. Replace the diode if necessary.
- 8.19.2 On “can style” relays (the glow plug relay on G 25, the starter relay on all other generators), check that the yellow wire of the diode is attached to the power terminal of the relay's coil (labeled “CP” on the schematic) and that the black wire is attached to the ground terminal of the relay's coil (labeled “CG” on the schematic). Correct the wiring as needed.

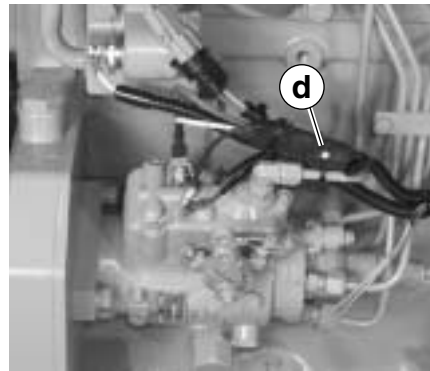
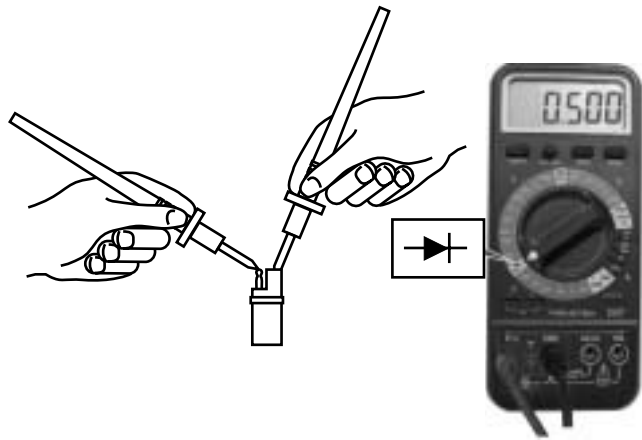
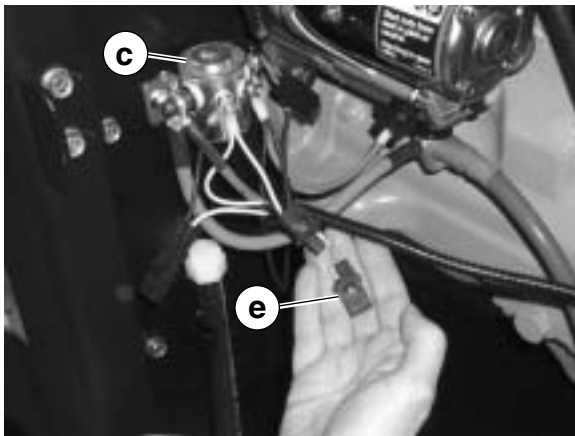
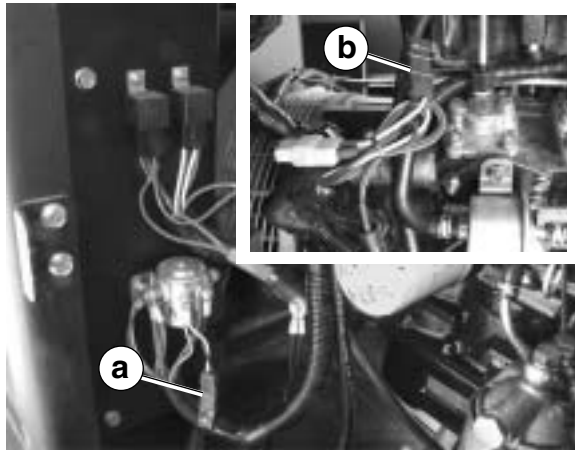

wc\_gr002803

## 8.20 Checking Coil of Starter Relay and Wiring

See Graphic: *wc\_gr0002816* and *wc\_gr002804*

- 8.20.1 Disconnect the wiring from the starter relay (16) terminals CP **(a)** and CG **(b)** and check the resistance across terminals CP and CG.
  - If  $100\pm 10\%$  Ohms is not measured, replace the starter relay.
  - If  $100\pm 10\%$  Ohms is measured, continue.
- 8.20.2 Place the start switch in the START/RUN position. During the cranking cycle, check for 12VDC between terminal CP **(b)** of the starter relay (21) and ground.
  - If 12VDC is measured, the relay's coil is receiving power; go to step 4.
  - If 12VDC is not measured, continue.
- 8.20.3 Disconnect the John Deere engine harness from the Wacker harness at the connector **(d)**. Check the continuity of yellow wire #63 from ECM pin 1, plug 2 to terminal **D** of the Wacker harness.
  - If the wire does not have continuity, repair or replace it.
  - If the wire has continuity, continue.
- 8.20.4 Check the continuity of the red wire from terminal **D** of the John Deere engine harness to terminal CP of the starter relay.
  - If the wire does not have continuity, repair or replace it.
  - If the wire has continuity, continue.
- 8.20.5 Continue checking the circuit by checking the continuity of the black wire on starter terminal CG **(c)** to ground. Repair wire as needed.
- 8.20.6 Reconnect all the wiring after tests are complete.

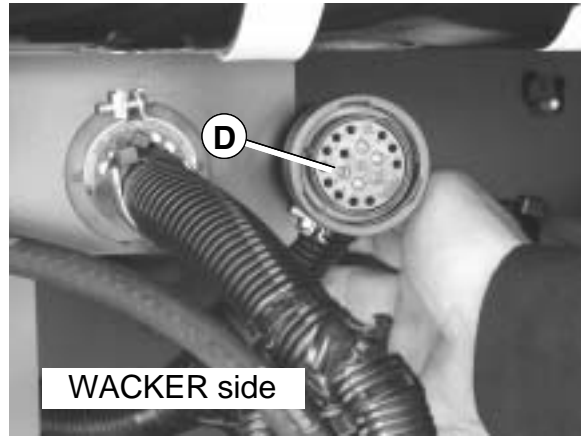
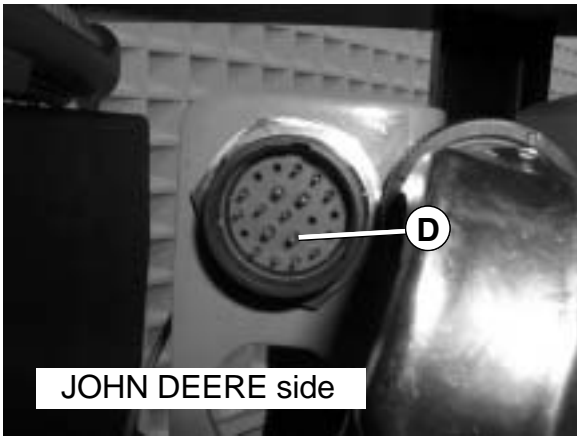
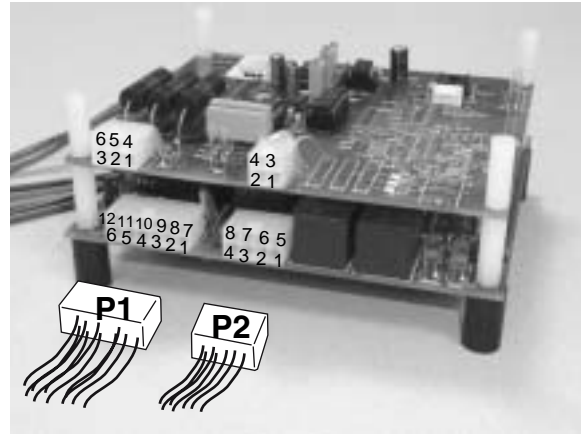
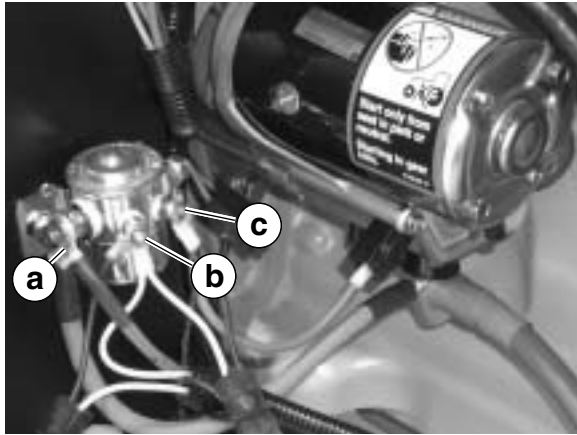

wc\_gr002804

## 8.21 Checking Contacts of Starter Relay and Wiring

See Graphic: *wc\_gr002805* and *wc\_gr002816*

- 8.21.1 Check for 12VDC (battery voltage approximately 12V) between terminal B+ SI **(a)** of the starter relay and ground.
- If 12VDC is not measured, check the continuity of the red wire from terminal B+ of the starter relay to terminal B+ of the starter motor. Also check the continuity of the red wire from the starter motor to the battery. Repair or replace the wiring as needed.
  - If 12VDC is measured, the relay is receiving power; continue.
- 8.21.2 Place the start switch in the START/RUN position and check for 12VDC between terminal SO **(b)** of the starter relay and ground during the cranking cycle.
- If 12VDC is not measured, the starter relay is malfunctioning; replace the starter relay.
  - If 12VDC is measured, continue.
- 8.21.3 Check for 12VDC between the red wire **(c)** at the starter motor solenoid and ground.
- If 12VDC is measured and the engine still does not crank, check the engine manufacturer's service manual for starter motor replacement procedures.
  - If 12VDC is not measured, continue.
- 8.21.4 Check the continuity of the red wire between terminal SO of the starter relay and the starter motor solenoid.
- If the wire does not have continuity, repair or replace it.

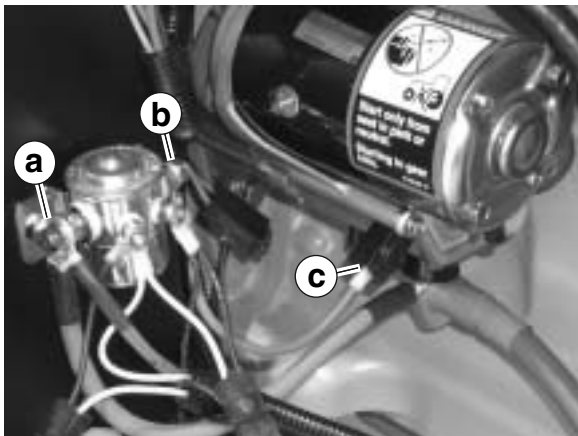

*wc\_gr002805*

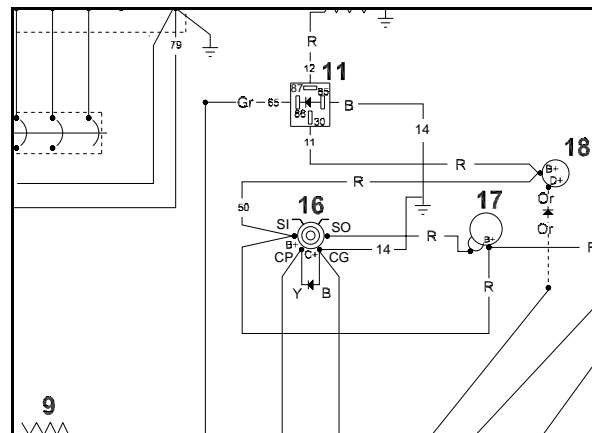

*Schematic wc\_gr002816 detail*

8.22 Engine Cranks But Does Not Start—*John Deere with ECU*

Engine Cranks But Does Not Start

Check fuel system: fuel supply, filter, condition of tank, and hoses.

Engine Troubleshooting  
**Flowchart 2J**  
*John Deere with ECU*

\* Battery voltage approximately 12V

**Checking Slave Preheat Relay and Wiring**

Preheat relay checks only apply when the generator is cold: approximately 15°C (60 F) and lower.

With the start switch in the START/RUN position, check for 12VDC\* on gray wire #65 at terminal 86 of slave preheat relay during the preheat (Air Intake Heater) cycle

Is there 12VDC\* on gray wire #65 at terminal 86?

No → Check continuity of gray wire #65/white wire #429 between relay terminal 86 and terminal K3 of the ECU harness connector. Repair wire as required.

Yes

Check continuity of black wire #13 from preheat relay terminal 85 to ground.

Does black wire have continuity?

No → Repair/replace wire.

Yes

Check for 12VDC\* on terminal 30 of preheat relay.

Is 12VDC\* measured at terminal 30?

No → Check continuity of red wire #11 from relay terminal 30 to alternator, then back to starter relay. Repair/replace wire as needed.

Yes

Check for 12VDC\* on terminal 87 of preheat relay during the preheat cycle.

Is there 12VDC\* on terminal 87?

No → Replace preheat relay.

Yes

See Flowchart 2K

wc\_gr002821

## Engine Cranks but does not Start Continued from Flowchart 2J

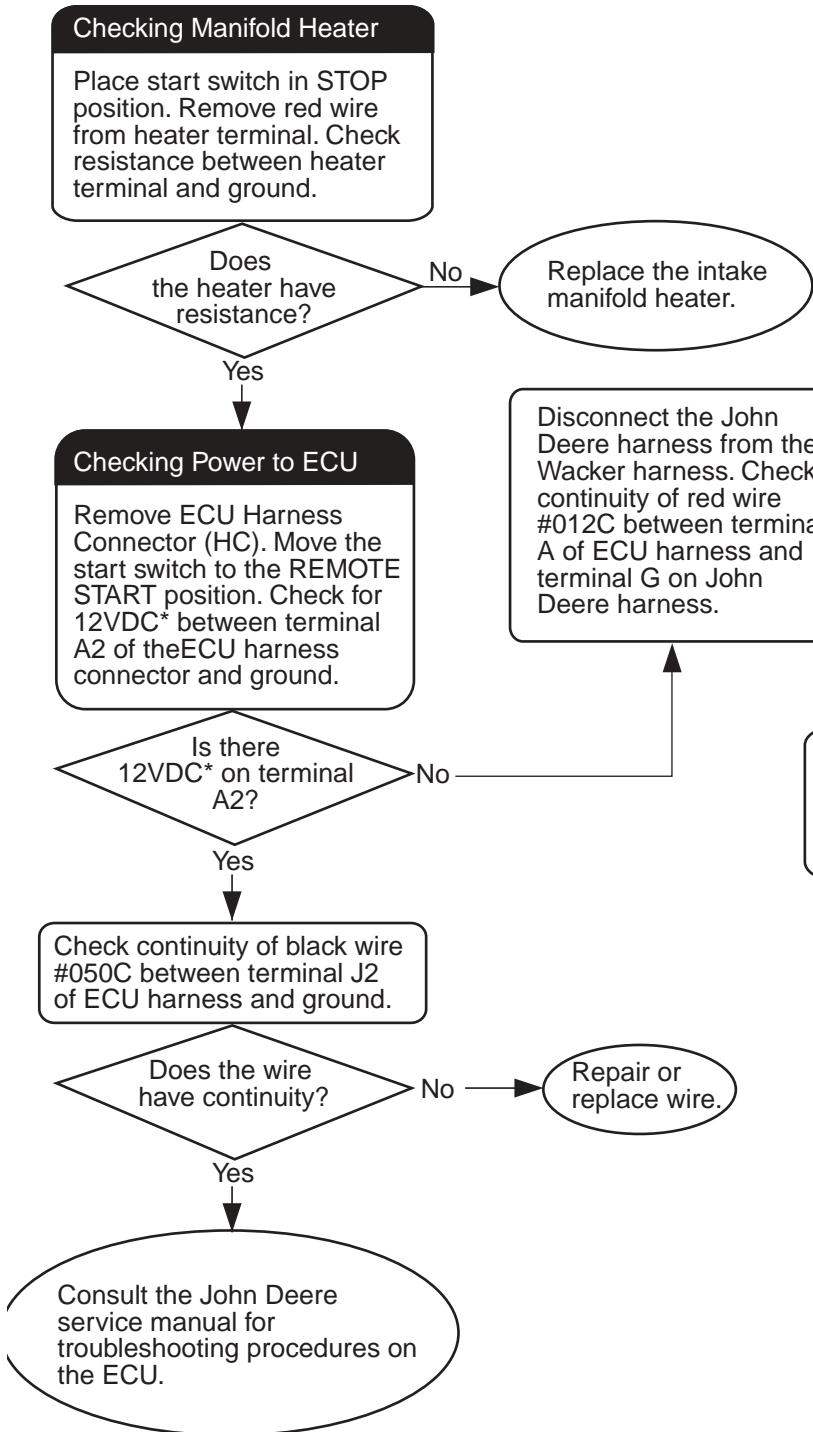

## Engine Troubleshooting Flowchart 2K John Deere

\* Battery voltage approximately 12V

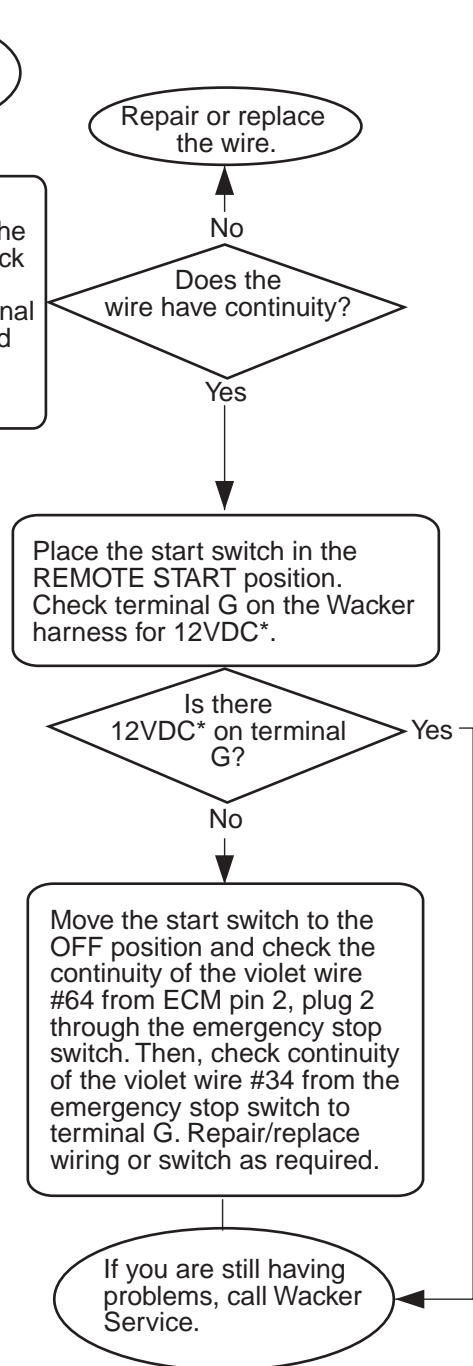

wc\_gr002822

## 8.23 Checking Slave Preheat Relay and Wiring

See Graphic: *wc\_gr002816* and *wc\_gr002825*

- 8.23.1 Place the start switch in the START/RUN position and check for 12VDC (battery voltage approximately 12V) between gray wire #65 at slave preheat relay **(a)** terminal 86 and ground.
- If 12VDC is not measured, check the continuity of gray wire #65, which becomes white wire #429, between the slave preheat relay and terminal K3 of the ECU harness connector **(b)**.
  - If 12VDC is measured, continue.
- 8.23.2 Place the start switch in the OFF position and check the continuity of black wire #13 between the slave preheat relay and ground.
- If the wire does not have continuity, repair or replace it.
  - If the wire has continuity, continue.
- 8.23.3 Place the start switch in the START/RUN position and check for 12VDC between red wire #11 and at the slave preheat relay and ground.
- If 12VDC is not measured, check the continuity of the red wire #11 between the slave preheat relay and the alternator. Also check the continuity of red wire #50 between the alternator and the starter relay. And finally, check the continuity of the red wire from the starter relay to the starter motor and back to the battery.
  - If 12VDC is measured, continue.
- 8.23.4 Check for 12VDC at terminal 87 of the slave preheat relay and ground. Measure at the relay or at red wire #12 connected to the intake manifold heater.
- If 12VDC is not measured, replace the slave preheat relay.
  - If 12VDC is measured, the slave preheat relay is operating properly.

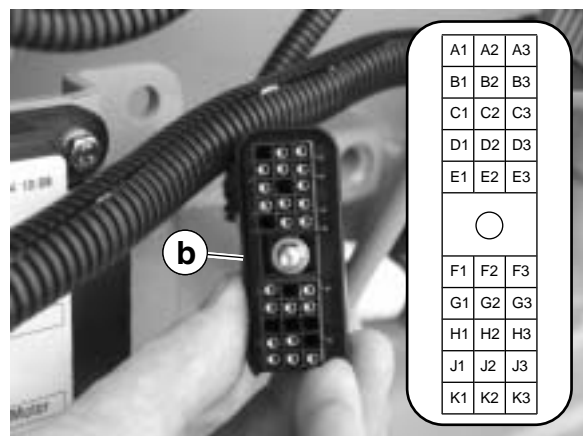
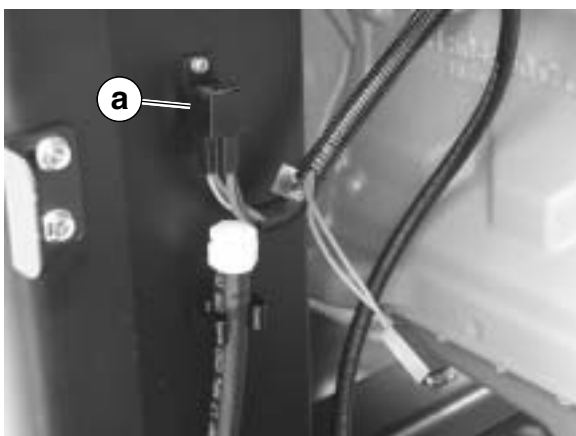

wc\_gr002825

## 8.24 Checking Manifold Heater

See Graphic: wc\_gr002808

The manifold heater **(e)** is located in line with the intake air supply.

- 8.24.1 Disconnect red wire #12 **(c)** from the manifold heater. Check the continuity of red wire #12 between the manifold heater and terminal 87 of the slave preheat relay. Repair/replace the wire as needed.
- 8.24.2 With red wire #12 disconnected, check the resistance of the manifold heater element by measuring between the heater terminal and the base of the manifold heater.
- If the manifold heater element is open (OL) or has no resistance (0 Ohms), replace it.
  - If the manifold heater element has resistance, further test its function by energizing it.
- 8.24.3 Loosen the hose clamp **(a)** and remove the air hose **(b)** from the coupling.  
Optional: Remove bolts **(d)** which secure the manifold heater to the manifold and remove the manifold heater **(e)**.
- 8.24.4 **WARNING** Burn hazard. The heater can reach temperatures up to 1000°F (538°C). Do not touch the element of the manifold heater. Be extremely careful when testing the manifold heater.



With the manifold heater base grounded, apply 12VDC to the manifold heater (at the terminal) for 10 seconds.

- If the manifold heater does not heat (glow) when 12VDC is applied, replace it.
- If the manifold heater glows, it is functioning.

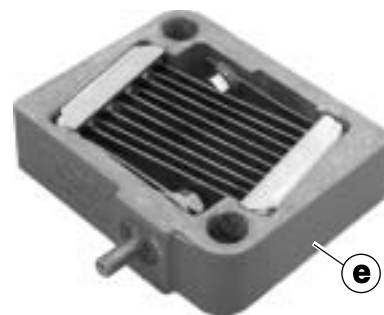
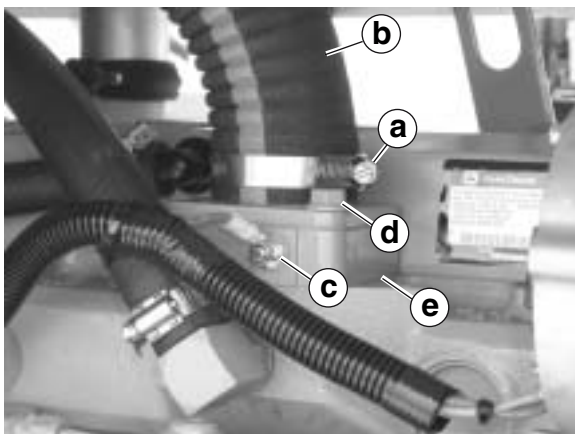

wc\_gr002808

## 8.25 Checking Contacts of ECM Fuel Relay

See Graphic: *wc\_gr002927*

In order for the ECM fuel relay to energize, the ECM must be receiving power. If the engine cranks, the ECM is receiving power. If the engine does not crank, see section *Checking ECM 10A Fuse*.

The engine's ECU receives control power through the ECM fuel relay. ECM fuel relay relays 12VDC first to the ECU through violet wire #64 via the emergency stop switch, then through violet wire #34 to the ECU. To check if the ECM fuel relay is functioning, carry out the following procedure:

- 8.25.1 Place the start switch in the REMOTE START position.
- 8.25.2 Probe pin 2, plug 2 and measure for voltage (battery voltage approximately 12). Measure between pin 2, plug 2 and ground.
  - If 12VDC is not measured, the ECM fuel relay is not functioning. Replace the ECM.
  - If 12VDC is measured, the ECM fuel relay circuit is functioning.

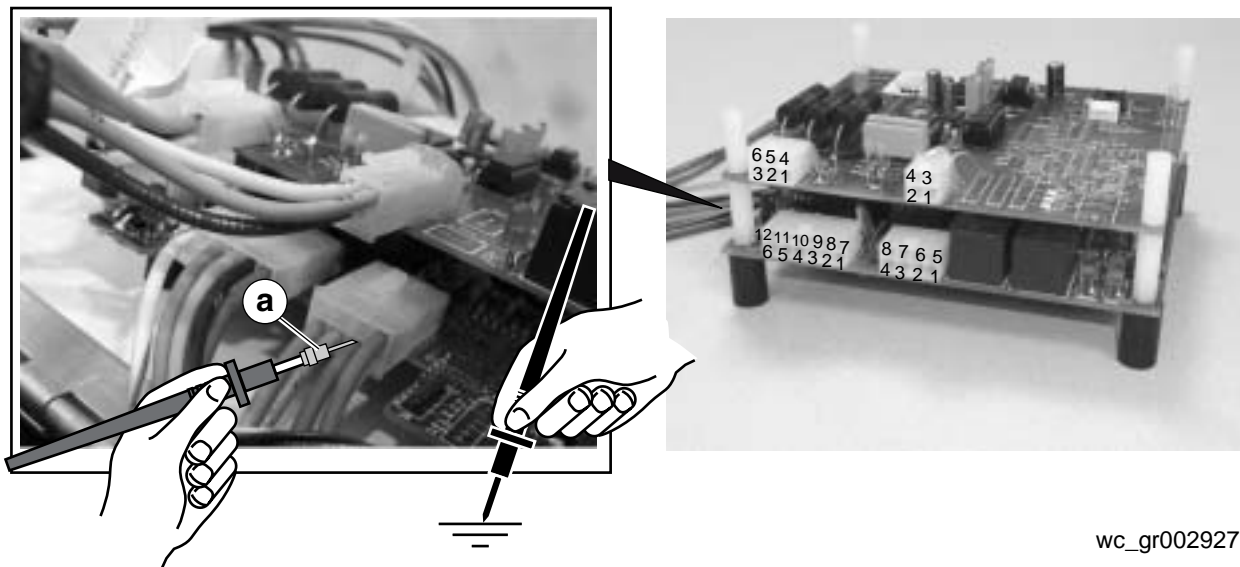

wc\_gr002927

## 8.26 Checking Power to ECU

See Graphic: *wc\_gr002816* and *wc\_gr002826*

Be sure the ECM fuel relay contact circuit is functioning. See section *Checking Contacts of ECM Fuel Relay*.

- 8.26.1 Remove the ECU harness connector **(a)**.
- 8.26.2 Place the start switch in the REMOTE START position.
- 8.26.3 Check for 12VDC (battery voltage approximately 12V) between terminal A2 of the ECU harness connector and ground.
  - If 12VDC is not measured, go to step 8.26.5.
  - If 12VDC is measured, continue.
- 8.26.4 Check the continuity of black wire #050C between terminal J2 of the ECU harness and ground.
  - If the wire does not have continuity, repair or replace it.
  - If the wire has continuity, consult the John Deere Service Manual for troubleshooting the ECU.
- 8.26.5 Place the start switch in the OFF position. Disconnect the John Deere engine harness from the Wacker harness at connector **(b)**. Check the continuity of red wire #012C between terminal A2 of the ECU harness connector and terminal **G** of the John Deere engine harness.
  - If the wire does not have continuity, repair or replace it.
  - If the wire has continuity, continue.
- 8.26.6 Place the start switch in the REMOTE START position. Check for 12VDC between terminal **G** on the Wacker harness and ground.
  - If 12VDC is measured at terminal **G** and your unit will still not start, the problem lies within the ECU. Consult the John Deere service manual for troubleshooting the ECU. Call Wacker Service.

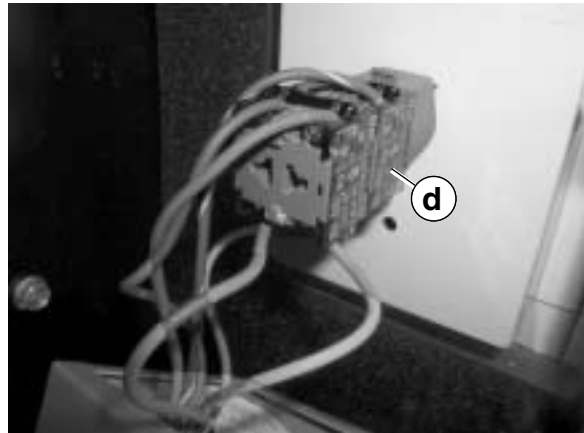
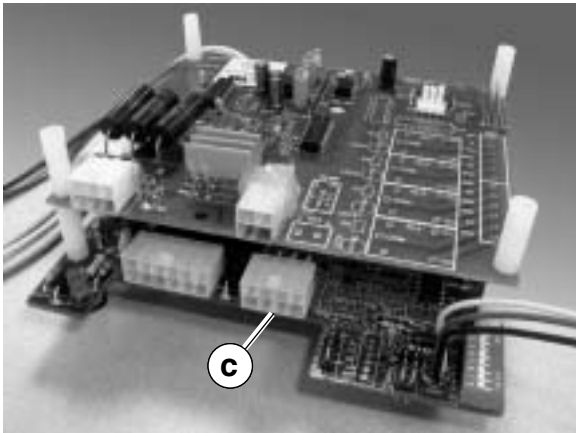
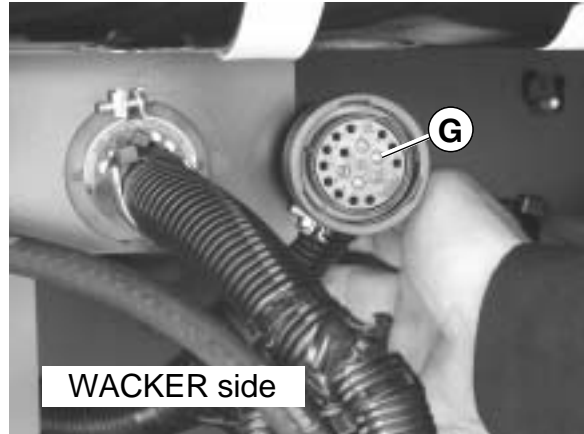
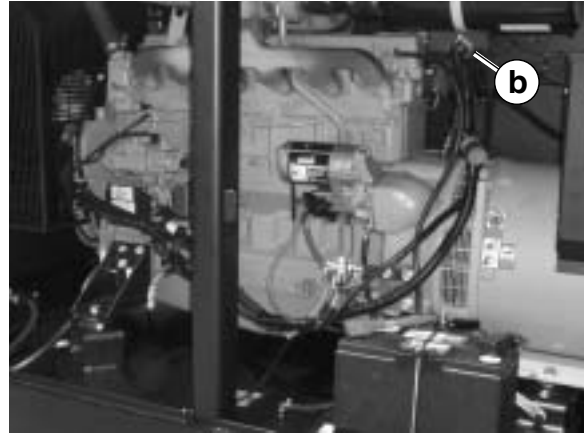
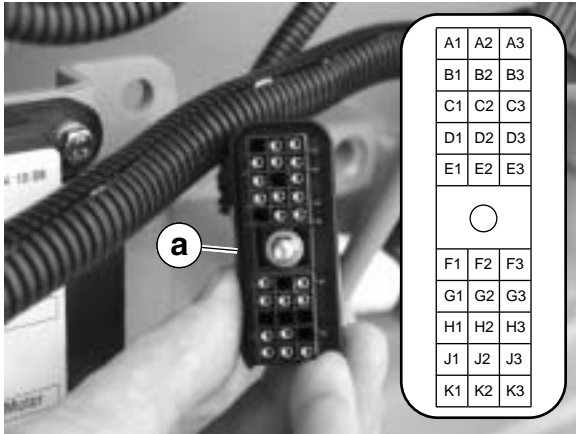

wc\_gr002826

8.27 General Engine Troubleshooting—*John Deere with ECU*

Symptom	Problem	Solution
Engine cranks but will not start	Exhaust restricted	Check and correct exhaust restriction.
	Fuel filter plugged or full of water	Replace fuel filter or drain water from filter.
	Injection pump not getting fuel or air in fuel system	Check fuel flow at supply pump or bleed fuel system.
	Faulty injection pump or nozzles	Consult authorized diesel repair shop for repair or replacement.
	No fuel	Check fuel tank and hoses.
Engine hard to start or will not start	Engine starting under load	Place all circuit breakers in OFF positions.
	No fuel	Check fuel tank and hoses.
	Air in fuel line	Bleed fuel line.
	Cold weather	Use cold weather starting aids.
	Crankcase oil too heavy	Use oil of proper viscosity.
	Improper fuel type	Use proper fuel type for operating conditions.
	Water, dirt or air in fuel system	Drain, flush, fill, and bleed fuel system.
	Clogged fuel filter	Replace filter element.
	Dirty or faulty injection nozzles	Have authorized service dealer or distributor check injectors.
	Injection pump shut-off not reset	Place start switch in OFF position, then to START.

Symptom	Problem	Solution
Engine knocks	Low engine oil level	Add oil to engine crankcase.
	Injection pump out of time	See authorized service dealer or distributor.
	Low coolant temperature	Remove and check thermostat.
	Engine overheating	See "Engine overheats" symptom in this chart.
Engine runs irregularly or stalls frequently	Low coolant temperature	Remove and check thermostat.
	Clogged fuel filter	Replace fuel filter element.
	Water, dirt, or air in fuel system	Drain, flush, fill, and bleed system.
	Dirty or faulty injection nozzles	Have authorized servicing dealer or engine distributor check injectors.
Lack of power	Engine overloaded	Reduce load.
	Intake air restriction	Service air cleaner.
	Clogged fuel filter	Replace filter elements.
	Improper type of fuel.	Use proper fuel.
	Overheated engine.	See "Engine overheats" symptom in this chart.
	Below normal engine temperature.	Remove and check thermostat.
	Improper valve clearance.	See authorized dealer or distributor.
	Dirty or faulty injection nozzles.	Have authorized service dealer or distributor check injectors.
	Injection pump out of time.	See authorized dealer or distributor.

Symptom	Problem	Solution
	Turbo charger not functioning (Turbocharge engines only).	See authorized dealer or distributor.
	Leaking exhaust manifold gasket.	See authorized dealer or distributor.
	Defective aneroid control line.	See authorized dealer or distributor.
	Restricted fuel hose	Clean or replace fuel hose.
Engine emits white smoke	Improper fuel type	Use proper fuel.
	Low engine temperature	Warm up engine to normal operating temperature.
	Defective thermostat	Remove and check thermostat.
	Defective injection nozzles	See authorized dealer or distributor.
	Engine out of time	See authorized dealer or distributor.
Engine emits black smoke	Improper fuel type	Use proper fuel.
	Clogged or dirty air cleaner	Service air cleaner.
	Engine overloaded	Reduce load.
	Injection nozzles dirty	See authorized dealer or distributor.
	Engine out of time	See authorized dealer or distributor.
	Turbocharger not functioning	See authorized dealer or distributor.

<b>Symptom</b>	<b>Problem</b>	<b>Solution</b>
Engine overheats	Engine overloaded	Reduce load.
	Low coolant level	Fill radiator to proper level. Check radiator and hoses for loose connections and leaks.
	Faulty radiator cap	See authorized dealer or distributor.
	Stretched poly-vee belt or defective belt tensioner	Check automatic belt tensioner and check belts for stretching. Replace belts as required.
	Low engine oil level	Check oil level. Add oil as required.
	Cooling system needs flushing	Flush cooling system.
	Defective thermostat	Remove and check thermostat.
	Defective temperature gauge or sender	Check water temperature with thermometer and replace temperature gauge or sender as required.
	Incorrect grade of fuel	Use correct grade of fuel.



See Graphic: wc\_gr002854

Ref.	Description	Ref.	Description
1	Lug safety limit switch	11	240V 30A receptacle
2	Mechanical lugs	12	Engine Control Module (ECM)
3	Buss bar	13	Plug 4 - line voltage inputs
4	Main breaker	14	Plug 3 - current transformer inputs
5	Shunt	15	Voltage Selector Switch
6	120V 20A GFI receptacle	16	Generator
7	120V breaker	17	Voltage regulator with 4A fuse
8	240V 50A breaker	18	Voltage adjustment rheostat
9	240V 30A breaker	19	Terminal Block
10	240V 50A receptacle	20	Terminal Strip

ECM Plug 3 Wires			ECM Plug 4 Wires		
Pin	Wire	Description	Pin	Wire	Description
4	Or 39	Ammeter line input CT3	3	Or 41	Voltage line input L3 at volt selector #28
1	W 36	Ammeter input CT common	4	Y 43	Voltage line input L2 at volt selector #20
5	Y 38	Ammeter line input CT2	2	Br 42	Voltage line input L1 at volt selector #3
2	Br 37	Ammeter line input CT1	-	-	---

Wire Colors							
B	Black	R	Red	Y	Yellow	Or	Orange
G	Green	T	Tan	Br	Brown	Pr	Purple
L	Blue	V	Violet	Cl	Clear	Sh	Shield
P	Pink	W	White	Gr	Gray	LL	Light blue

## G 50, G 70, G 85, G 125

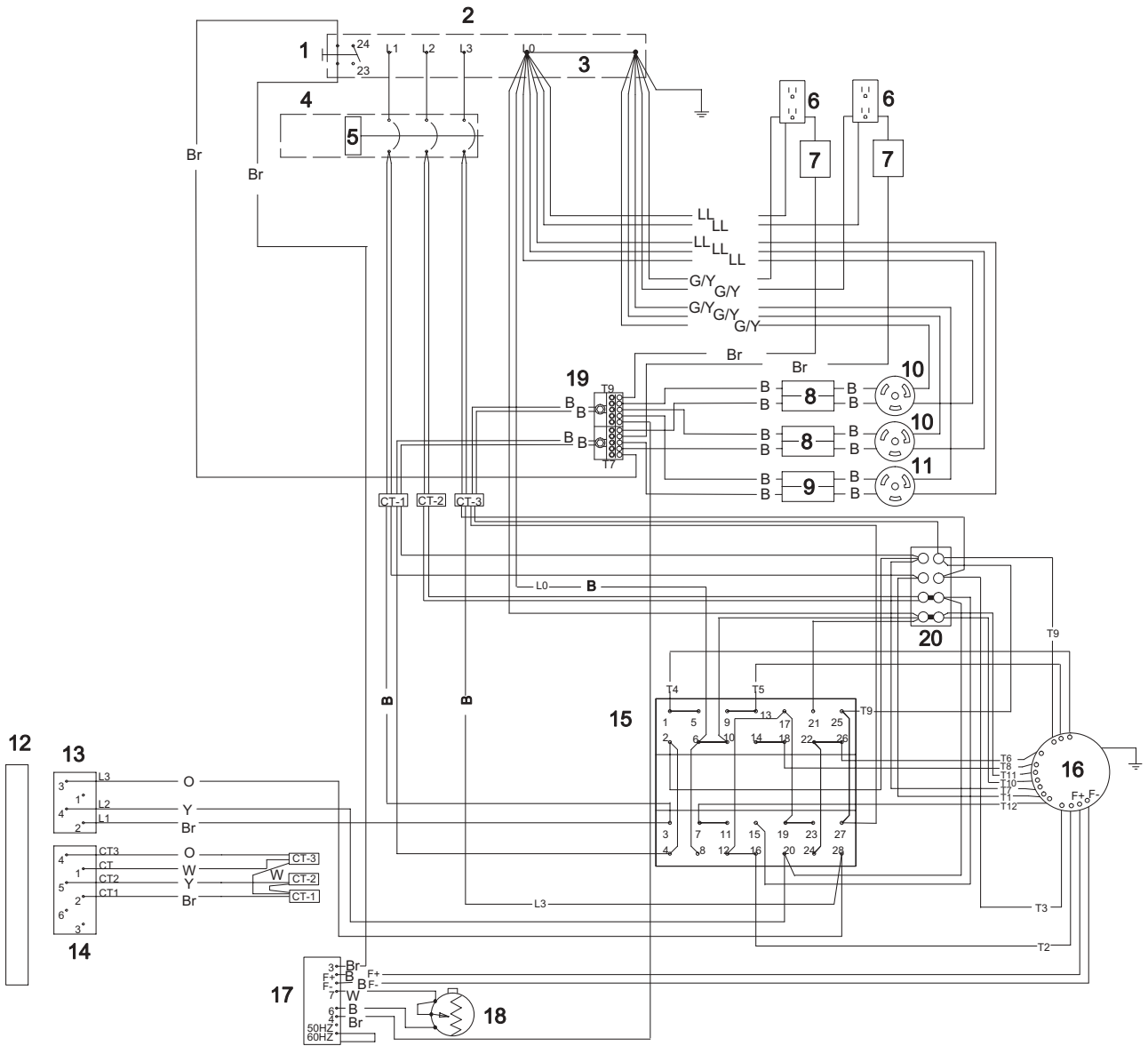

wc\_gr000524

See Graphic: wc\_gr000524

Ref.	Description	Ref.	Description
1.	Lug safety limit switch	11.	240V 30A receptacle
2.	Mechanical lugs	12.	Engine Control Module (ECM)
3.	Buss bar	13.	Plug 4 - line voltage inputs
4.	Main breaker	14.	Plug 3 - current transformer inputs
5.	Shunt	15.	Voltage selector switch
6.	120V 20A GFI receptacle	16.	Generator
7.	120V breaker	17.	Voltage regulator
8.	240V 50A breaker	18.	Voltage adjustment rheostat
9.	240V 30A breaker	19.	Terminal Block
10.	240V 50A receptacle	20.	Terminal Strip

ECM Plug 3 Wires			ECM Plug 4 Wires		
Pin	Wire	Description	Pin	Wire	Description
4	Or	Ammeter line input CT3	3	Or	Voltage line input L3 at volt selector #28
1	W	Ammeter input CT common	4	Y	Voltage line input L2 at volt selector #20
5	Y	Ammeter line input CT2	2	Br	Voltage line input L1 at volt selector #3
2	Br	Ammeter line input CT1	1	-	---

Wire Colors							
B	Black	R	Red	Y	Yellow	Or	Orange
G	Green	T	Tan	Br	Brown	Pr	Purple
L	Blue	V	Violet	Cl	Clear	Sh	Shield
P	Pink	W	White	Gr	Gray	LL	Light blue



See Graphic: wc\_gr000895

Ref.	Description	Ref.	Description
1	Lug safety limit switch	11	240V 30A receptacle
2	Mechanical lugs	12	Engine Control Module (ECM)
3	Buss bar	13	Plug 4 - line voltage inputs
4	Main breaker	14	Plug 3 - current transformer inputs
5	Shunt	15	Voltage selector switch
6	120V 20A GFI receptacle	16	Generator
7	120V breaker	17	Voltage regulator
8	240V 50A breaker	18	Voltage adjustment rheostat
9	240V 30A breaker	19	Terminal Block
10	240V 50A receptacle	20	Terminal Block

ECM Plug 3 Wires			ECM Plug 4 Wires		
Pin	Wire	Description	Pin	Wire	Description
4	Or	Ammeter line input CT3	3	Or	Voltage line input L3 at volt selector #28
1	W	Ammeter input CT common	4	Y	Voltage line input L2 at volt selector #20
5	Y	Ammeter line input CT2	2	Br	Voltage line input L1 at volt selector #3
2	Br	Ammeter line input CT1	1	-	---

Wire Colors							
B	Black	R	Red	Y	Yellow	Or	Orange
G	Green	T	Tan	Br	Brown	Pr	Purple
L	Blue	V	Violet	Cl	Clear	Sh	Shield
P	Pink	W	White	Gr	Gray	LL	Light blue

**9.2 "No" Voltage Troubleshooting  
(Zero (0.0) Volts measured on multimeter)**

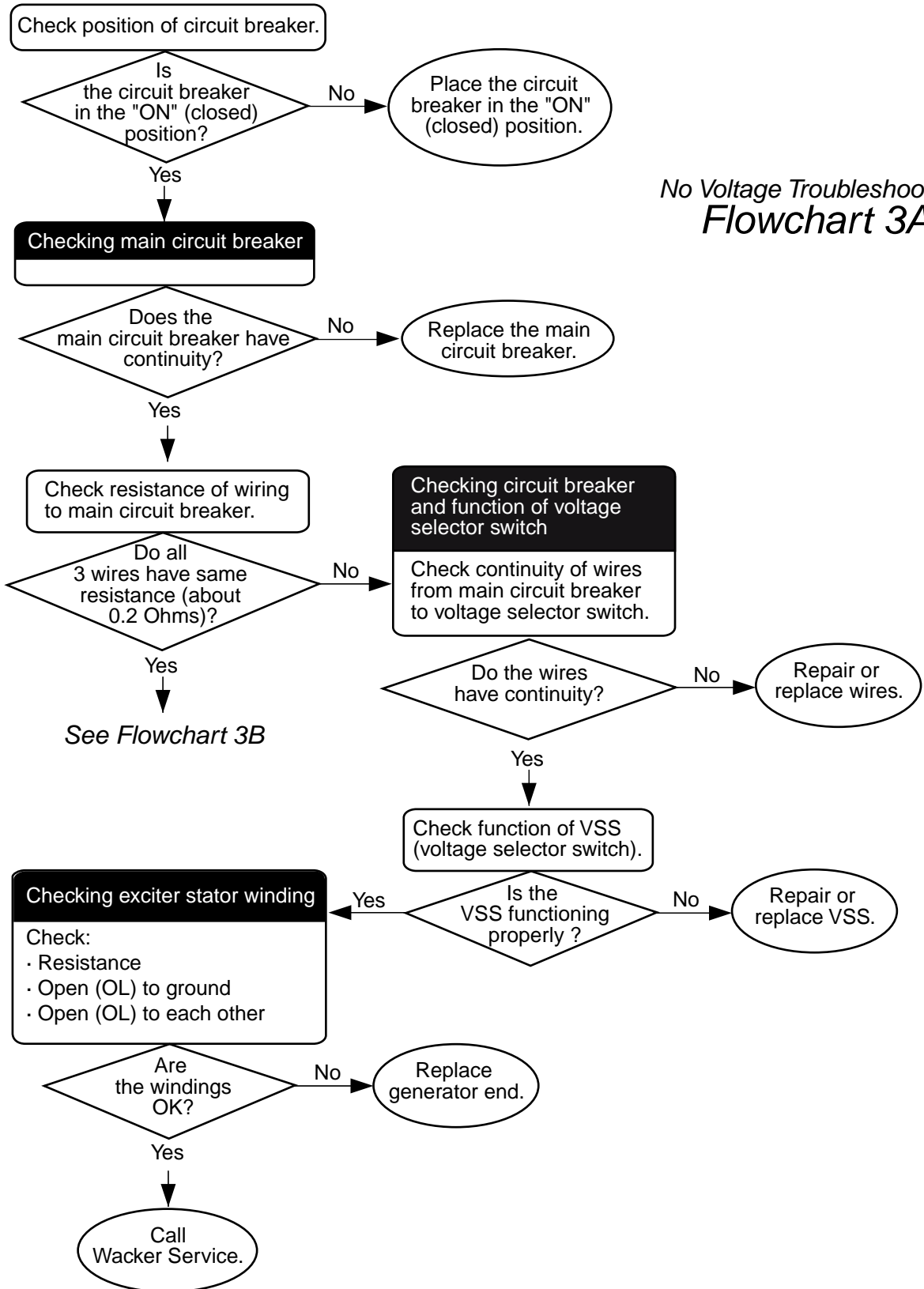

No Voltage Troubleshooting  
**Flowchart 3A**

No Voltage Troubleshooting  
**Flowchart 3B**

Continued from Flowchart 3A

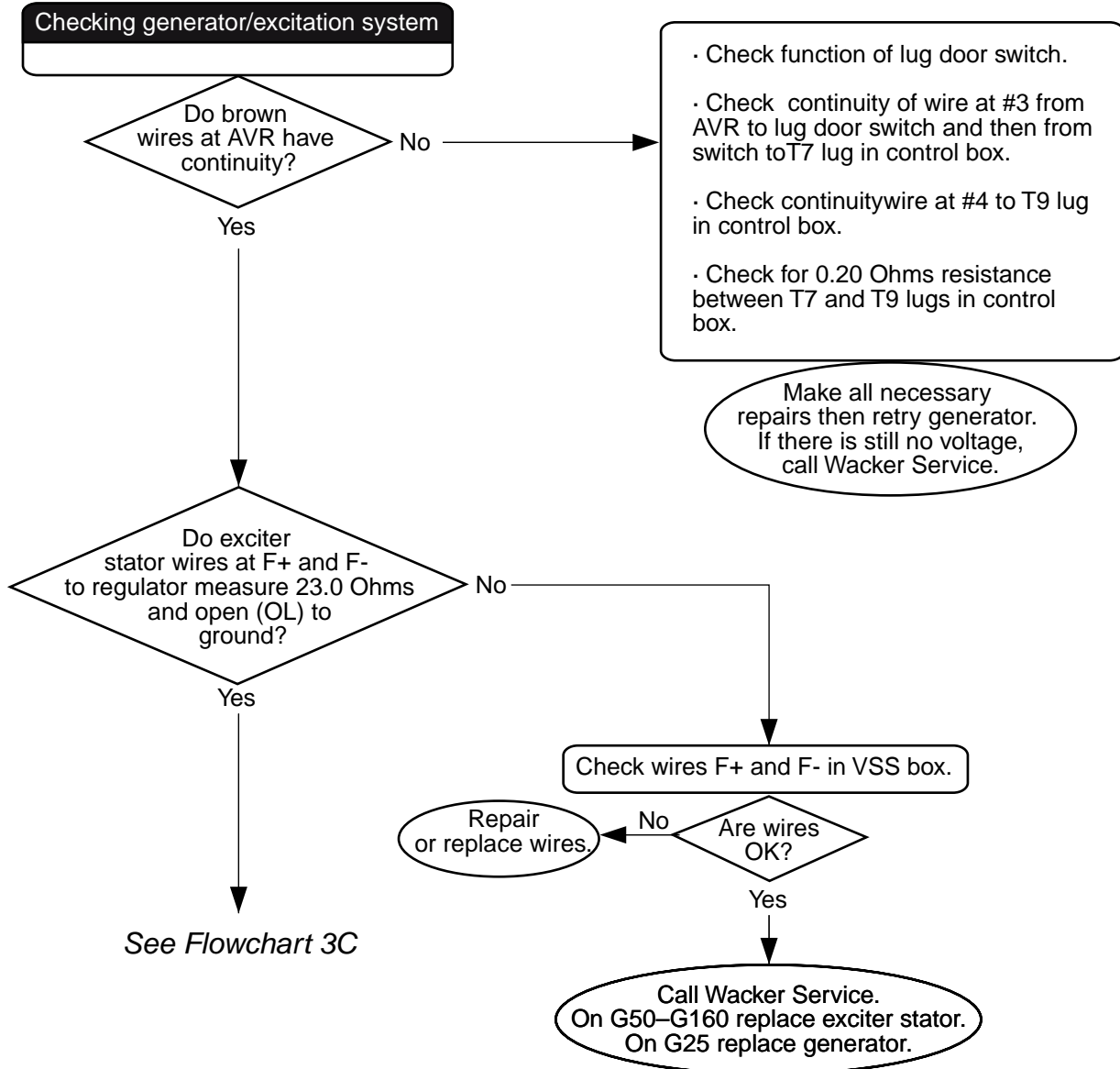

wc\_gr002846

No Voltage Troubleshooting  
Flowchart 3C

Continued from Flowchart 3B

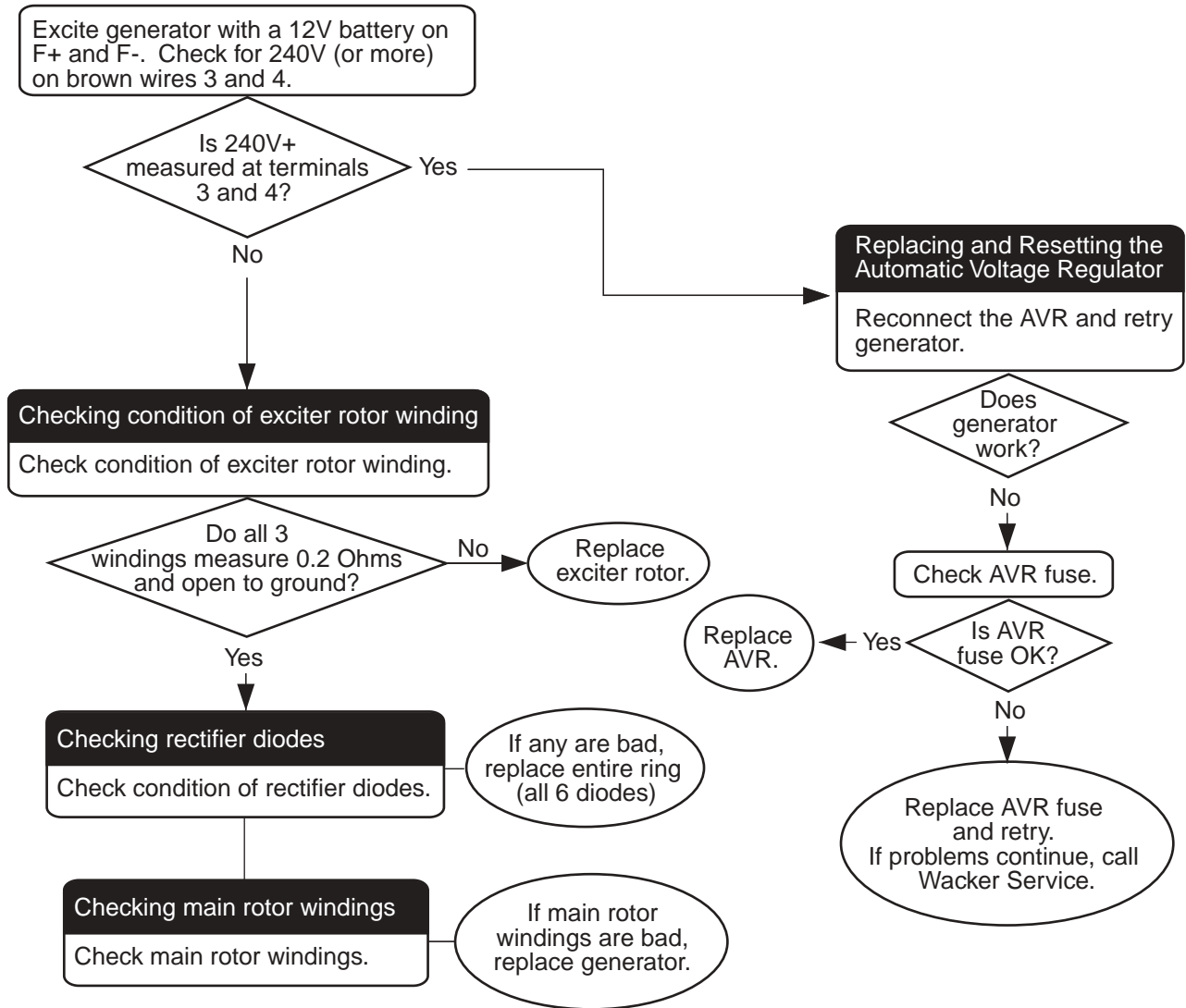

wc\_gr002862

### 9.3 Checking Main Circuit Breaker

See Graphic: *wc\_gr002855*



**WARNING**

Electric shock hazard. Turn off the generator before conducting this test.

- 9.3.1 Open the control panel and place the main circuit breaker in the “ON” (closed) position.
- 9.3.2 Check the main circuit breaker for continuity—on all three legs. If the main circuit breaker has no continuity when in the “ON” position, replace it.

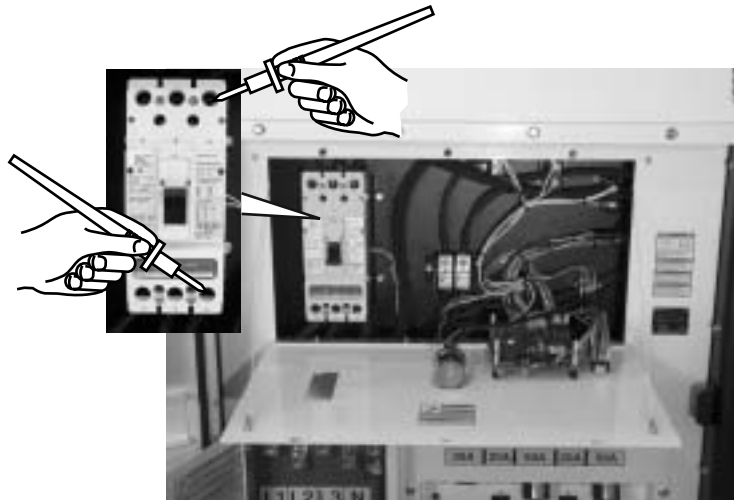

*wc\_gr002855*

## 9.4 Checking Circuit Breaker and Function of Voltage Selector Switch

See Graphic: *wc\_gr002856*

- 9.4.1 Turn off the generator.
- 9.4.2 Place the voltage selector switch (VSS) in the 480V/277V position.
- 9.4.3 Open the control panel. Measure the resistance from each leg to neutral: L1–N, L2–N, and L3–N. Do so by measuring resistance across each wire connected to the top of the main circuit breaker to neutral lug. All three resistance values should be equal—approximately 0.2 Ohms.
  - If there is an “open” reading, repair the broken wire to the VSS.
  - If there is a significant increase in one of the measurements, check the wire connections on the voltage selector switch. Tighten any loose wires.
- 9.4.4 If wires are OK, spray contacts of VSS with a contact cleaner and turn the VSS knob back and forth several times to wipe clean the switch contacts. Dry the VSS thoroughly with compressed air and retest the resistance reading on each leg to neutral.
- 9.4.5 If a high resistance reading is still present, remove four wires off both coils on the suspect leg (e.g., if L3–N, measures 10 Ohms, remove T6 from 26, T9 from 25, T12 from 7, and T3 from lug in VSS box. Check resistance from wires T3 to T6, and from T9 to T12.
  - If a high resistance is measured on either coil, replace the stator.
  - If both coils measure 0.2 Ohms and are “open” to ground, then check the resistance on VSS contacts 25 to 26. If high resistance is measured on the VSS, clean it again, or replace it.

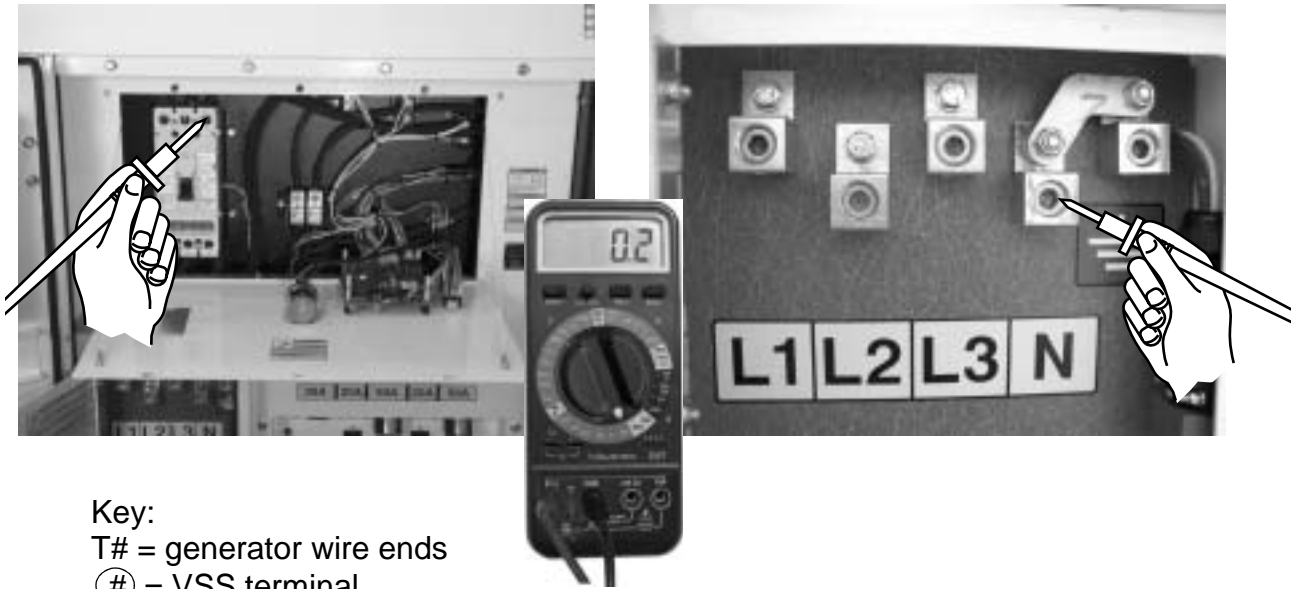

Key:  
 T# = generator wire ends  
 # = VSS terminal

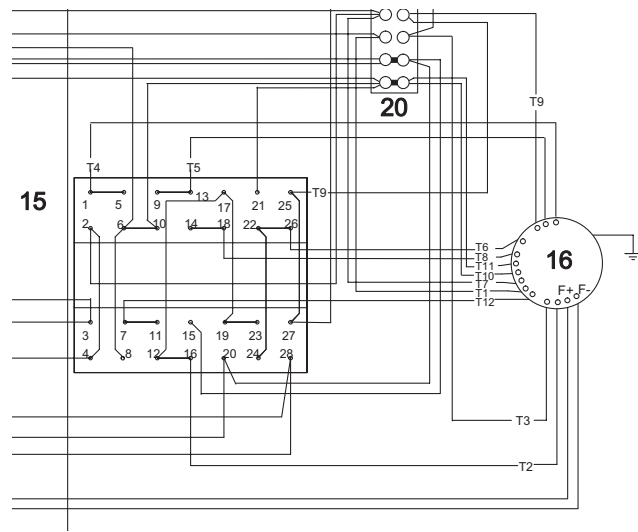
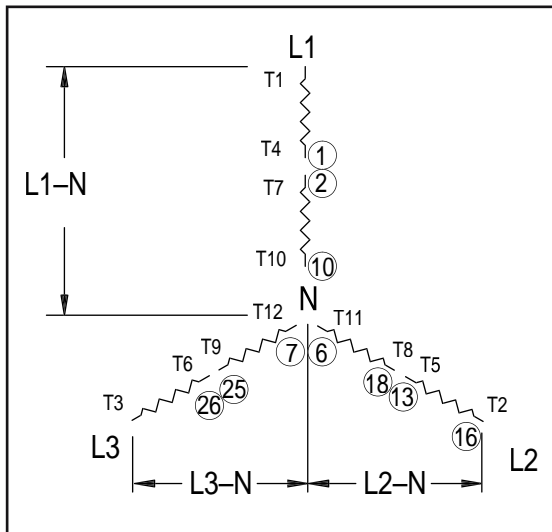

wc\_gr002856

## 9.5 Replacing Voltage Selector Switch (VSS)

See Graphic: *wc\_gr002123* and *wc\_gr002124*

Removal:

- 9.5.1 Place the engine start switch in the "O" (OFF) position and push in the emergency stop button.
- 9.5.2 Remove the rear enclosure panel to expose the generator. Remove the cover of the voltage selector switch box.
- 9.5.3 Label if necessary, then remove all the wires connected to the voltage selector switch.
- 9.5.4 Remove the screw **(a)** securing the selector knob **(b)** and remove the knob. Also remove adapter **(c)**.
- 9.5.5 Remove the face plate **(d)**.
- 9.5.6 Remove the hardware **(e)** and remove the switch lock **(f)**.
- 9.5.7 Remove the hardware **(g)** securing the rear of the switch and remove the switch **(h)** from the box.

Installation:

- 9.5.8 Position the switch into the switch box so that even number terminals are on the right and the serial number tag **(i)** faces up. Secure the switch with hardware **(g)**.
- 9.5.9 Secure the switch lock **(f)** using hardware **(e)**.
- 9.5.10 Snap the face plate **(d)** back onto the lock.
- 9.5.11 Attach adapter **(c)** and selector knob **(b)** with screw **(a)**.
- 9.5.12 Reconnect wiring and jumpers as shown. Jumpers **(j2)** are built-in to switches used on G25.
- 9.5.13 Re-install switch box cover and sides. Also replace rear enclosure panel.

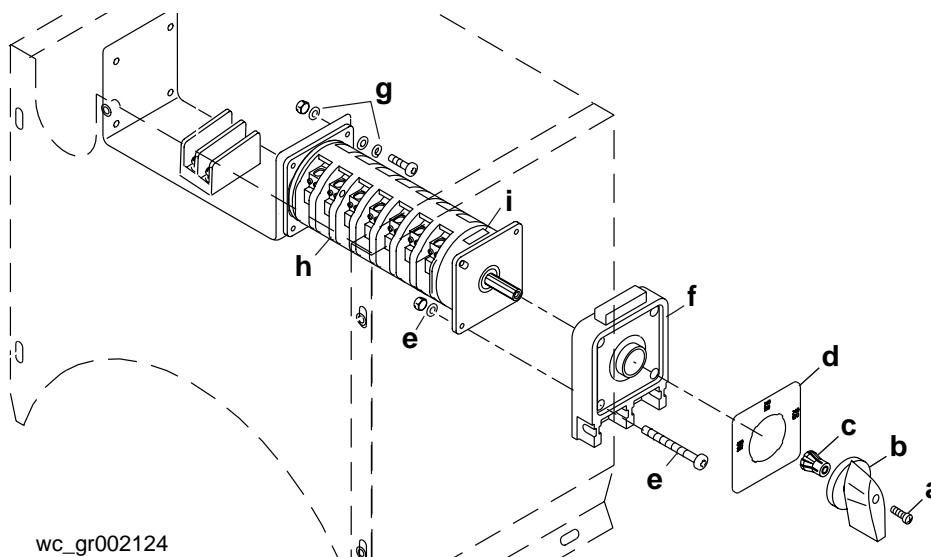

wc\_gr002124

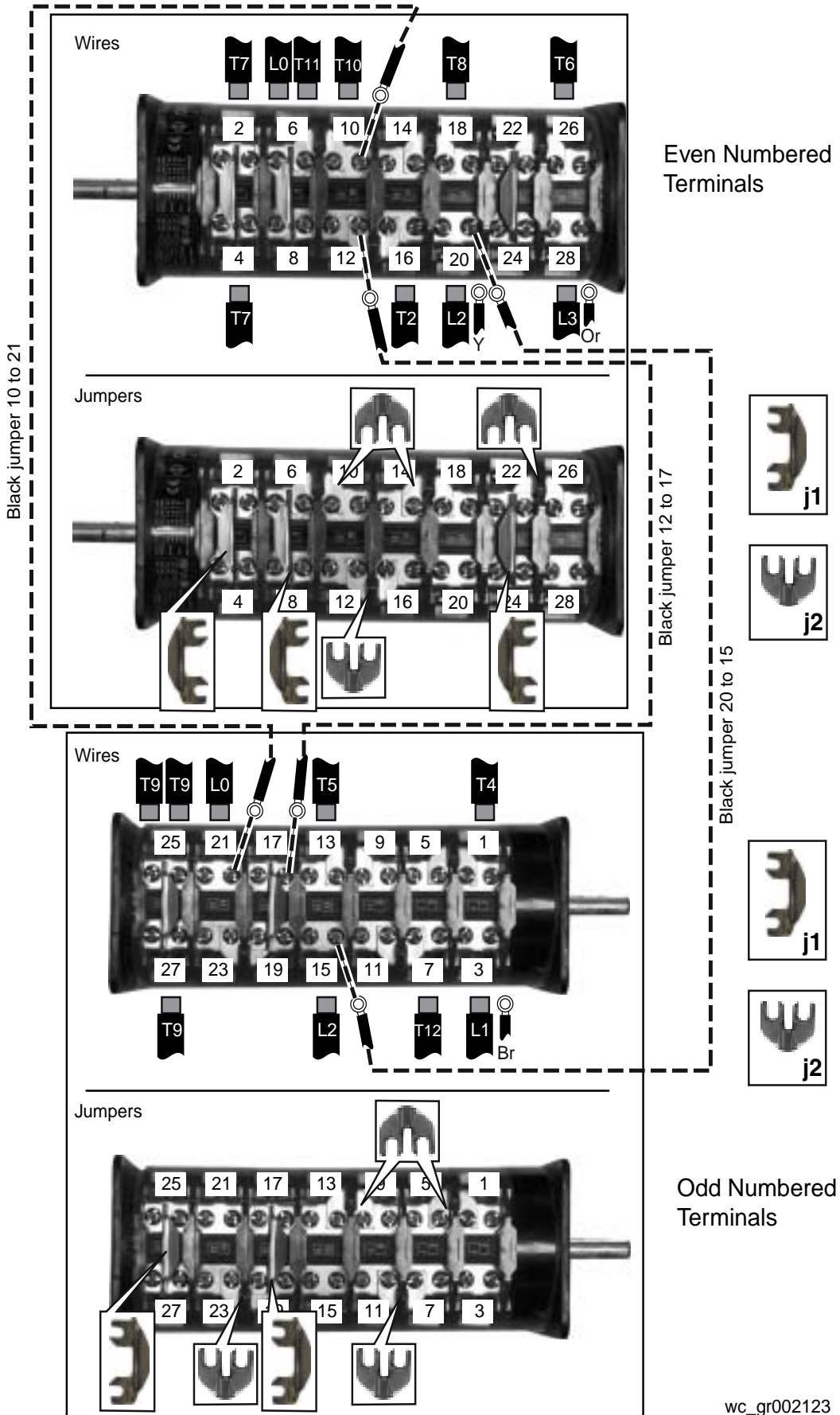

wc\_gr002123

## 9.6 Checking Exciter Stator Winding

See Graphic: *wc\_gr002103*

- 9.6.1 Remove exciter stator wires F+ and F- from the voltage regulator and check continuity between wires. There should be approximately 23 (-0.0 +0.5) Ohms resistance between F+ and F-, and infinite (open) resistance from either wire to ground. If 23 Ohms is read, then the exciter stator is OK.
- 9.6.2 If 23 Ohms was not measured, trace the F+ and F- wires into the voltage selector switch box.
- 9.6.3 Remove the cover of the switch box and trace wires to red and black wires **(a)** coming from generator. Remove the F- wire from the black wire, and the F+ wire from the red wire.
- 9.6.4 Check both the F+ wire and the F- wire for continuity back to the voltage regulator. If either wire has no continuity, replace it.
- 9.6.5 Check the exciter stator winding for continuity by measuring the resistance across the red and the black cloth-covered generator wires. There should be approximately 23 (-0.0 +0.5) Ohms resistance across the wires. If you do not measure 23 Ohms, replace the exciter stator. On G12 and G25 models, replace the complete generator assembly. Also check for short to ground. Measure resistance from red wire to ground, then black wire to ground. There should be infinite (open) resistance from either wire to ground.
- If you measure a resistance less than 2.0 megohms, replace the exciter stator winding. On G12 and G25 models, replace the complete generator assembly.
  - If you measure between 2.0 and 999 megohms, dry the windings off with a fan or hair dryer—humidity can reduce the reading.
- 9.6.6 An alternative test is to use a 500V megger. When using a 500V megger, the minimum resistance value between the winding and ground is 2 megohms. Replace the winding or generator if you read 2 megohms or less.

**Note:** *On models G50–G160, the exciter stator comes off with removal of generator bearing carrier. On models G12 and G25, the exciter is pressed into the stator can assembly.*



wc\_gr002103

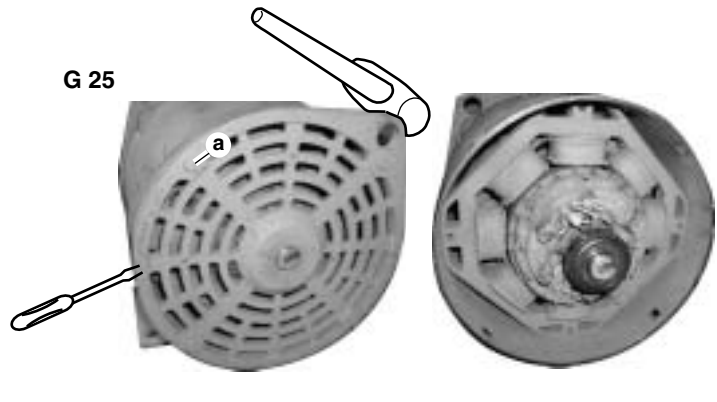

G 50, G 70, G 85, G 125, & G 160

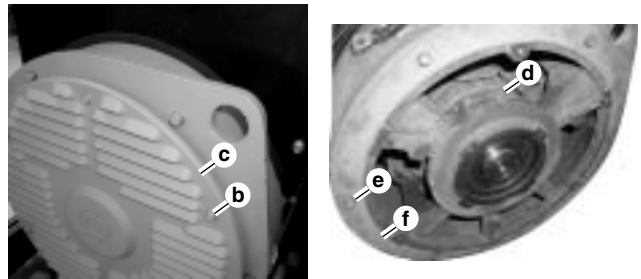

wc\_gr002774

## 9.7 Accessing the Rotor Bearing, Diodes, and Rotor Winding

See Graphic: *wc\_gr002774*

- 9.7.1 On generators with Isuzu engines, remove screws **(a)** and nuts securing support cover. Tap the cover with a hammer to open a gap between the cover and the generator housing, then use a screwdriver to pry the cover all the way off the housing.
- 9.7.2 On generators with John Deere engines, remove the screws **(b)** securing the plastic vent cover **(c)** and remove the plastic cover. This will allow minimal access to the diode ring **(d)**.
- 9.7.3 For improved access, disconnect the F+ and F- wires in the VSS box. Then, remove screws **(e)** and remove bearing carrier/exciter stator assembly **(f)**.

## 9.8 Checking Generator/Excitation System (Including Manual Excitation/Flashing)

See Graphic: wc\_gr002857

Field testing of the voltage regulator requires special equipment and is not practical or necessary. By removing the voltage regulator from the circuit and testing the excitation system, one can determine by process of elimination whether the problem lies within the regulator or the excitation system.

Signs that the voltage regulator may be malfunctioning are:

- Generator output voltage limited to approximately 30VAC.
- Generator comes up to voltage when flashing the exciter stator, but not when connected to the automatic voltage regulator (AVR).

9.8.1 With the engine off, check the condition of the AVR's 4-Amp fuse (**a**). Replace the fuse if blown. A blown fuse is a sign that F+ or F- may be shorted to ground.

9.8.2 Remove black wires F+, F-, brown wires 3 and 4 from the AVR.

9.8.3 With the wires disconnected from the AVR, the generator output voltage is reduced to a residual voltage of approximately 10–30VAC.

**Note:** *During normal operation, the voltage inputs to the AVR will measure approximately 240VAC on brown wires 3 and 4. The output excitation from AVR terminals F+ and F- can go as high as 73VDC, depending on the type of load on the generator.*

9.8.4 Check the resistance across the F+ and F- wires. There should be approximately  $23 \pm 0.5$  Ohms resistance across F+ and F-, and infinite (open) resistance from either wire to ground. If unusual resistance is measured across F+ and F-, trace the wires back to the voltage selector switch box. The F+ wire is connected to the red wire leading into the generator housing where it is connected to the exciter stator. The F- wire is connected to the black wire of the exciter stator. Repair or replace wires as needed. See section *Checking Exciter Stator Winding*.

9.8.5 Check the resistance across brown wires 3 and 4. There should be very low resistance measured, approximately 0.2 Ohms. And each wire should have a path to ground.

**Note:** *The interlock switch is part of this circuit. When the lug box door is closed, the circuit is completed and there is continuity. When the door is opened, there should be no continuity (meter reading of OL, or Open) across 3 and 4. If your meter shows something different, replace the interlock switch. See section *Checking Safety Interlock Switch*.*

If your meter shows no continuity between brown wires 3 and 4 with the interlock switch closed, check the continuity of each wire separately. To do so, open the interlock switch by removing screw **(b)**. Note the brown wire #3 **(c)** leading to AVR. Check it for continuity. Also check the wire on the opposite side of the interlock switch **(d)** back to the T7 lug **(e)** located inside control box, for continuity. Then, check wiring from T7 lug back to voltage selector switch for continuity. Finally, check brown wire #4 between AVR and T9 lug **(f)**, and the wires from T9 lug back to voltage selector switch, for continuity. Repair or replace wires as needed.

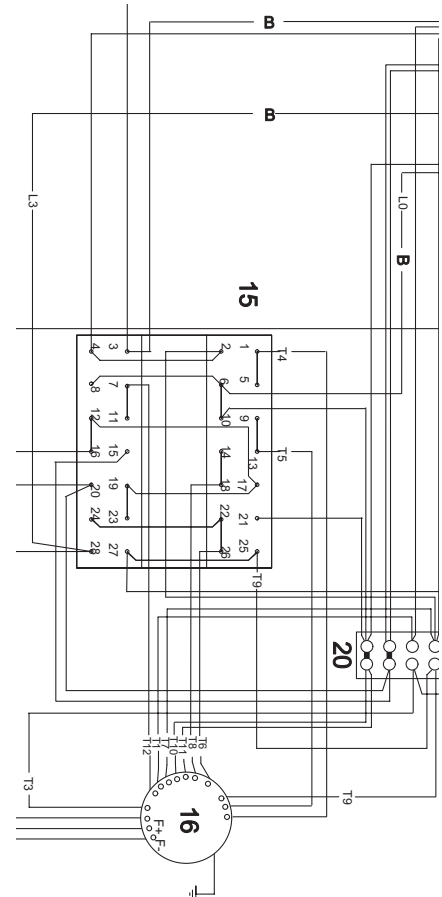
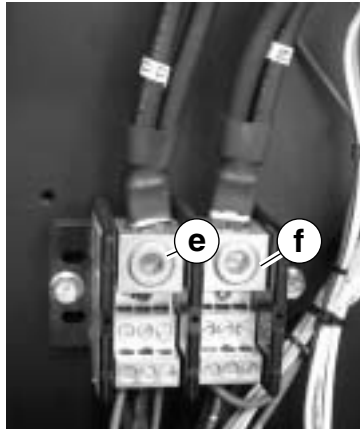
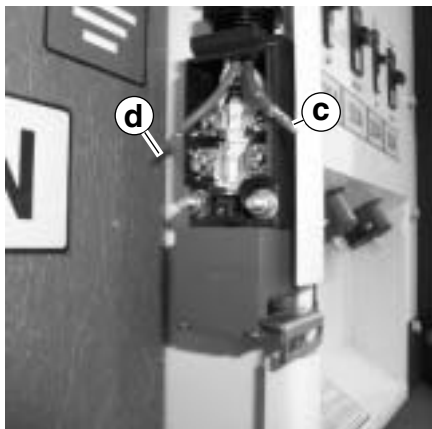
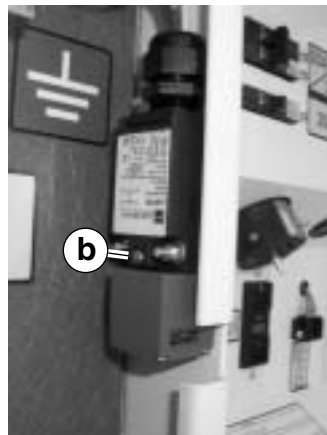
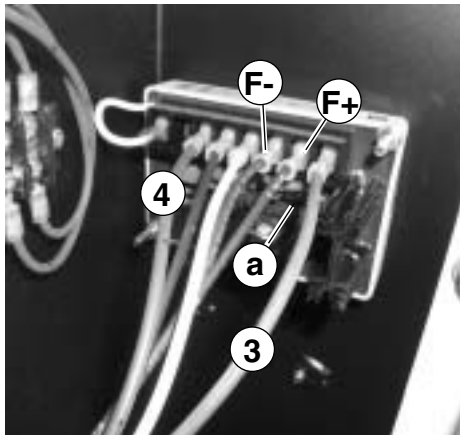

wc\_gr002857

**External battery excitation/flashing procedures**

See Graphic: *wc\_gr001951*

The exciter stator core is the main source of the generator's residual magnetism. If it has been subjected to severe vibration during shipping, it may have lost its residual magnetism. To restore residual magnetism, flash the field as described below.

To flash the field:

- 9.8.6 With engine off, disconnect black wires F+ and F-, and brown wires 3 and 4, from the regulator.
- 9.8.7 Connect a multimeter to brown wires 3 and 4. Set the multimeter to a voltage scale of minimum 300VAC or higher.
- 9.8.8 Explosion hazard. Escaping hydrogen gas from the battery can explode. Beware of arcing when connecting leads to battery.



Connect the F+ and F- wires to a 9- or 12-Volt battery by using jumper wires between them and the battery. The F+ and F- wires are the exciter field leads. Be sure to connect F+ to positive and F- to negative or residual magnetism will be lost again when the regulator is reconnected. When connecting the wires, connect the jumper wires to the battery first, then connect them to the F+ and F- wires away from the battery—connect the F+ wire first, then the F- wire.

- 9.8.9 Start the engine and observe the voltage on the brown wires 3 & 4 with a multimeter. Using a 9-Volt battery, the generator should produce approximately 180–200 Volts; with a 12-Volt battery, 240–300 Volts .
- If voltage output on brown wires (3 & 4) is very low, check: the exciter rotor, the diode ring, and the main rotor.
  - If voltage is correct, the excitation system is functioning properly.

Run the generator for a few seconds to restore residual magnetism to exciter stator core. Turn engine off, remove jumper wires and re-connect F+ and F-, and brown wires to voltage regulator.

- If voltage is incorrect when automatic voltage regulator (AVR) is reconnected, check the AVR fuse and replace it if necessary.

If the voltage is still incorrect or the fuse blows again, replace the AVR.

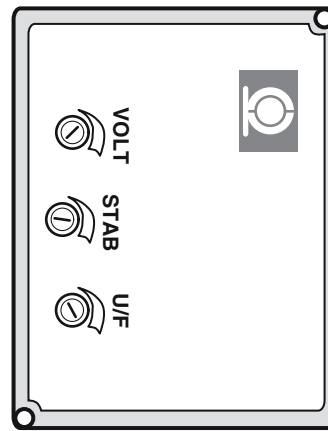
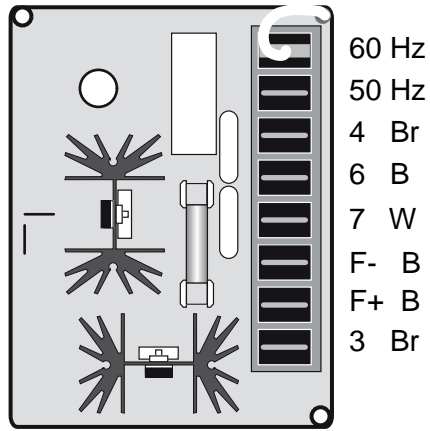

wc\_gr001951

## 9.9 Checking Lug Door Switch

See Graphic: *wc\_gr002110*

There are two sets of contacts in the door switch. The first set is normally open. These contacts open the brown AVR wire #3 to turn off the AVR when the door is opened.

The second set is normally closed. These contacts close the yellow shut trip circuit breaker wires to 12V from battery, causing the breaker to open when the door is opened.

Electric shock hazard. Turn off the generator before conducting this test.



### WARNING

- 9.9.1 Open the hinged panel and defeat the interlock switch. To defeat the interlock switch, remove “key” (latch) **(a)** from hinged panel and place it in slot of interlock switch **(b)**.
- 9.9.2 Open the switch by removing the screw **(c)**.
- 9.9.3 Disconnect the wires leading to the switch (caution, the yellow wire carries 12V.) Check the brown wire for continuity and the yellow wire should be “open”.  
Next, pull the “key” from the interlock switch. The brown wire’s contacts should now be “open” and the yellow wire’s contacts closed. If the interlock switch does not respond accordingly, replace the interlock switch.
- 9.9.4 **Re-install the key latch when test is completed.**

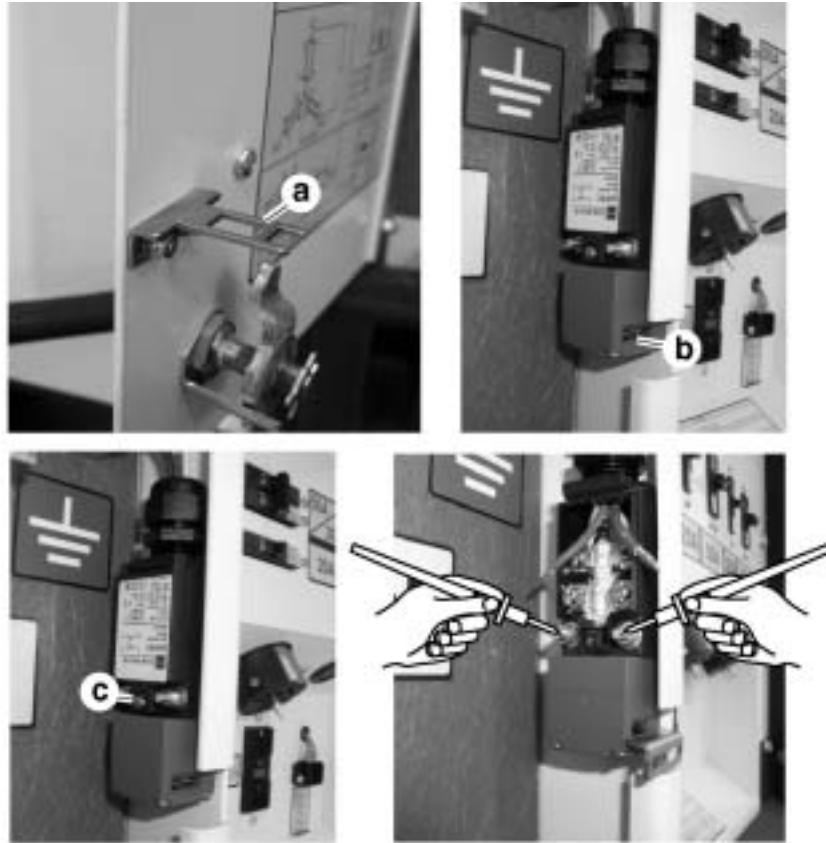

wc\_gr002110

## 9.10 Replacing and Resetting the Automatic Voltage Regulator (AVR)

See Graphic: *wc\_gr002858*

### Removal:

- 9.10.1 Place the engine start switch in the “O” (OFF) position and push in the emergency stop button.
- 9.10.2 Label then disconnect the wires connected to the automatic voltage regulator (AVR).
- 9.10.3 Remove the screws **(a)** and remove the AVR.

### Installation:

- 9.10.4 Remove and discard the wire jumper connected to terminals #6 and #7 on the replacement AVR. This jumper enables the volt adjustment on the AVR; however, it is not required because the remote voltage adjusting rheostat mounted on the control panel door is wired in its place.
- 9.10.5 Using screws, secure the replacement AVR to the panel.
- 9.10.6 Connect the wiring as shown. Be sure to connect white wire **(b)** to 60Hz terminal.

### AVR setup:

- 9.10.7 Place the voltage selector switch (VSS) in the 120/208V position.
- 9.10.8 Set the voltage adjusting rheostat **(c)** on the door to approximately the midway position (1-1/4 turns clockwise).
- 9.10.9 Start the engine and using the “volt” pot on the back of the AVR, set AC output voltage to 208V as seen on the ECM display, or measured with a multimeter connected to the lugs or the 50A twist-lock receptacle.
- 9.10.10 Turn the voltage adjusting rheostat clockwise until the display voltage reads 240V. If the voltage adjusting rheostat stops before reaching 240V, turn the voltage adjusting rheostat 1/8-turn counterclockwise from its max point and turn the “volt” pot on the AVR until output is 240V. A properly set AVR and voltage adjusting rheostat will allow a voltage adjustment range between 208–240V.
- 9.10.11 Once the AVR is set for the 208V position of the VSS, it is also set for all VSS positions. Adjustments via the voltage adjusting rheostat will allow an electrician to set up the generator for all rated applications.
- 9.10.12 Consult the factory if you encounter setup difficulties.

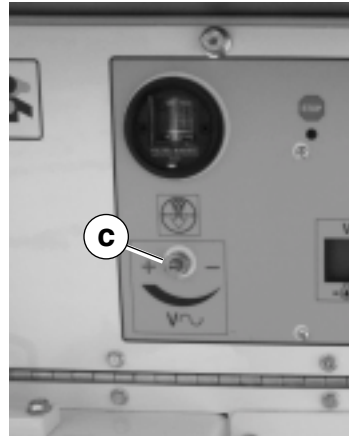
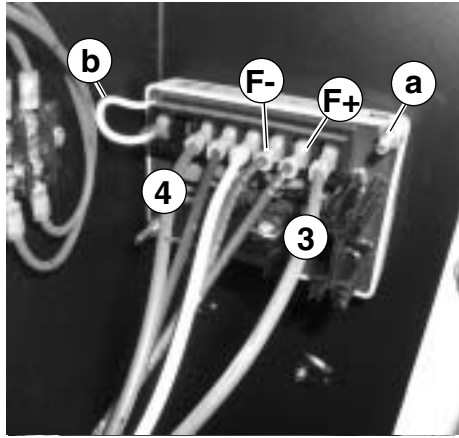

wc\_gr002858

## 9.11 Checking Exciter Rotor Winding

See Graphic: wc\_gr002106

**Note:** For clarity, the rotor is shown removed from generator housing.

- 9.11.1 Disconnect the three black wires (a) fastened to the diode support brackets. These black wires run to the exciter rotor winding. Arbitrarily label the three black wires "1", "2", and "3".
- 9.11.2 Measure the resistance across each combination of wires: 1–2, 2–3, and 1–3. The resistance measurement for each combination should be the same, approximately 0.2 Ohms. If each combination does not measure 0.2 Ohms replace the exciter rotor winding. See section *Replacing Rotor Bearing, Diode Ring, and Exciter Rotor*.
- 9.11.3 Also check each wire to ground. There should be no path to ground for any of the three wires. If you measure a path to ground, replace the exciter rotor winding.  
An alternative test is to use a 500V megger. When using a 500V megger, the minimum resistance value between the winding and ground is 2 megohms.



## 9.12 Checking Rectifier Diodes

See Graphic: wc\_gr002104

**Note:** For clarity, the rotor is shown removed from generator housing.

- 9.12.1 Locate the two threaded studs **(b)** on the diode ring and remove all wires fastened to them.
- 9.12.2 Identify the leads from each diode **(a)**.
- 9.12.3 Set the multimeter to the diode scale. Check that each diode conducts one way and not the other. A functioning diode should read  $0.500 \pm 0.025$  Volts one way and "open" the other.
- 9.12.4 Replace all six diodes if any of the diodes are found to be bad.

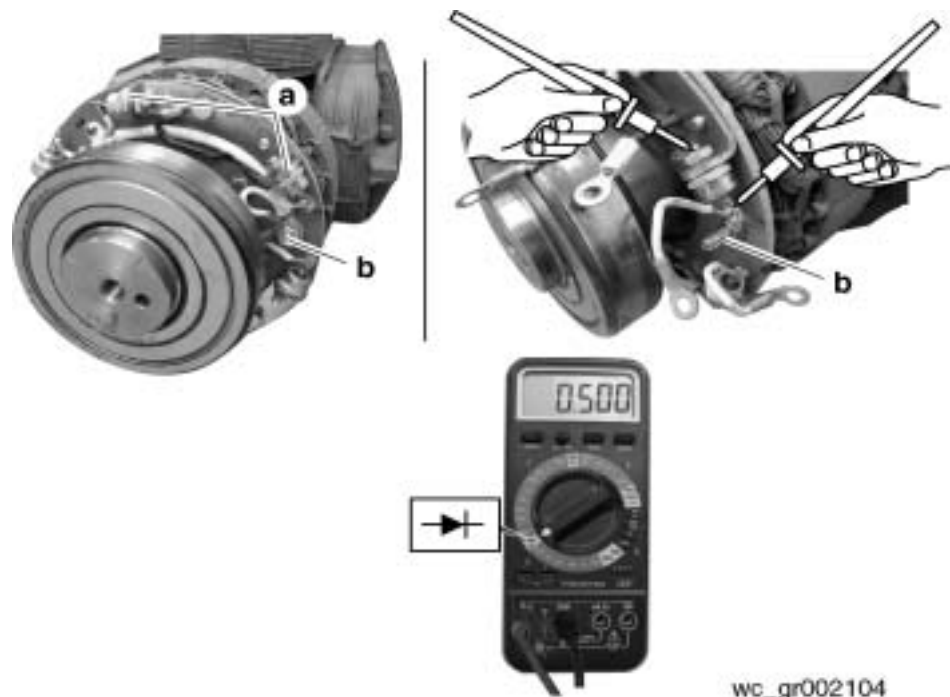

### 9.13 Checking Main Rotor Winding

See Graphic: *wc\_gr002107*

**Note:** *For clarity, the rotor is shown removed from generator housing.*

- 9.13.1 Locate two threaded studs **(b)** on diode ring. Remove all wires fastened to the studs.
- 9.13.2 Locate the two black wires with yellow insulators that run down motor shaft **(a)**.
- 9.13.3 Measure the resistance across the wires; it should equal  $1.4 \pm 0.5$  Ohms. If not, replace the generator assembly.
- 9.13.4 Also check each wire to ground. There should be no path to ground. If you measure a path to ground, replace the generator assembly.

**Note:** *Rotor assemblies are not available as replacement parts.*

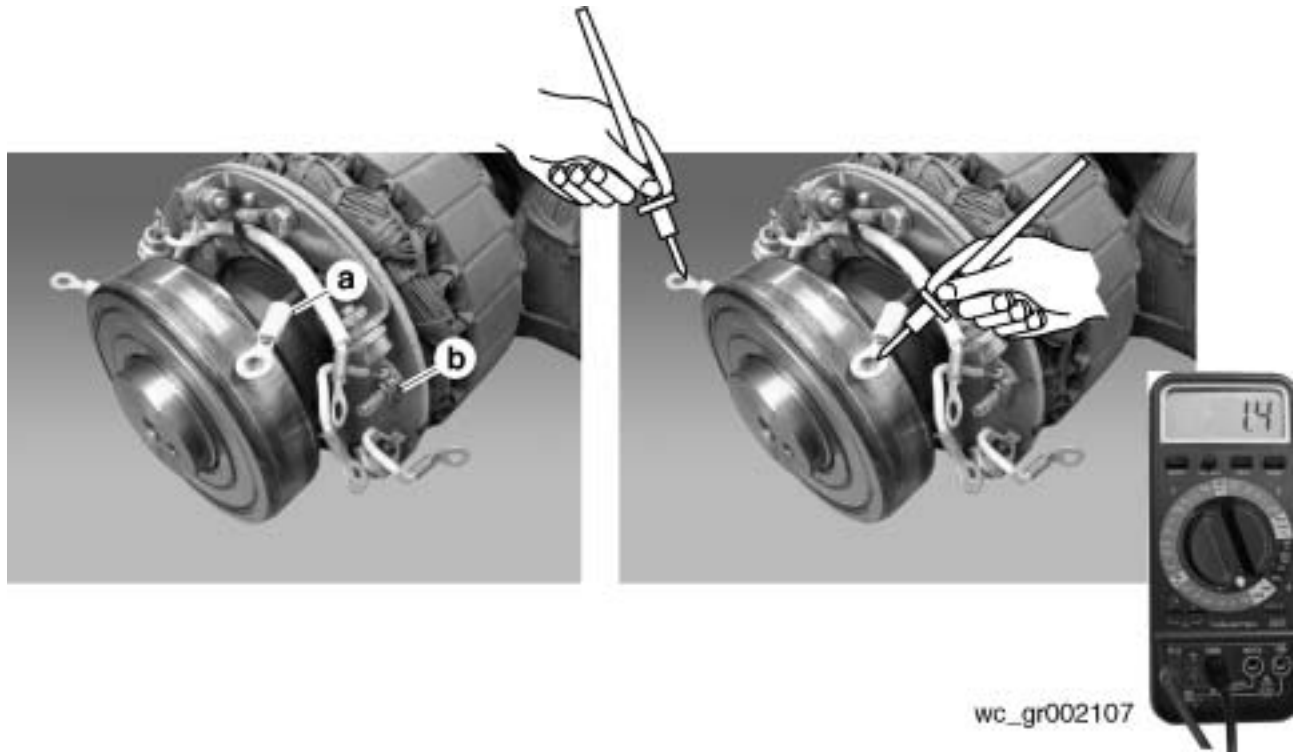

## 9.14 Replacing Rotor Bearing, Diode Ring, and Exciter Rotor

See Graphic: *wc\_gr002105*

### Removal:

- 9.14.1 Using a puller, pull the bearing **(a)** from the shaft. Heat the bearing if necessary but do not heat it more than 212°F (100°C).
- 9.14.2 Disconnect the black exciter rotor wires and the main rotor winding wires (black with yellow insulator) from the diode ring **(b)**.
- 9.14.3 Remove the screws securing the the ring to the collar **(c)** and remove the ring.
- 9.14.4 Using a puller, pull the collar from the shaft. Heat the collar if necessary.
- 9.14.5 Using a puller, pull the exciter rotor winding **(d)** from the shaft. Heat the exciter rotor winding if necessary

### Installation:

- 9.14.6 Align the exciter rotor winding so that the two main rotor winding wires **(e)** (black with yellow insulator) can pass through the holes in the exciter rotor winding and press the exciter rotor winding onto the rotor shaft.
- 9.14.7 Align the diode ring collar so that, when the diode ring is installed, the main rotor windings and the exciter rotor winding wires can be easily attached to the diode ring. Once aligned, press the collar onto the rotor shaft.
- 9.14.8 Attach the diode ring to the collar.
- 9.14.9 Connect the exciter and main rotor winding wires to the diode ring.
- 9.14.10 Press the bearing onto the rotor shaft. Heat the bearing race if necessary but do not heat it more than 212°F (100°C).

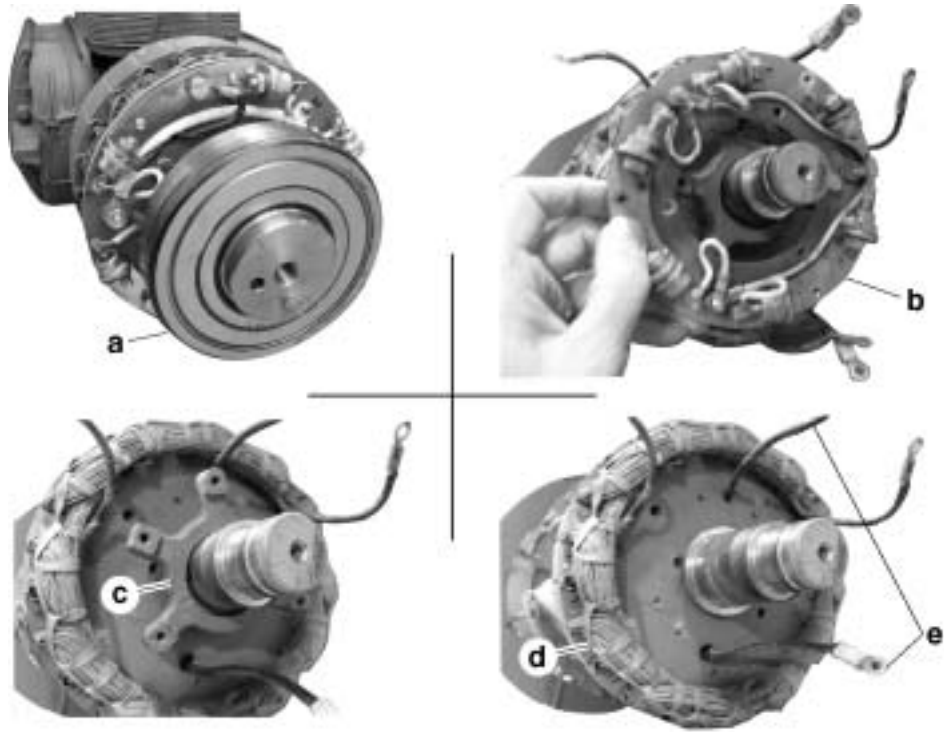

wc\_gr002105

## 9.15 Low\* Voltage Troubleshooting (\*Greater than 1; usually 30–40)

Check position of voltage selector switch. Make sure it is in the correct position.  
 Check the lug door. Make sure it is shut tight.  
 Check the function of the door switch. If the switch is not functioning properly, replace it.

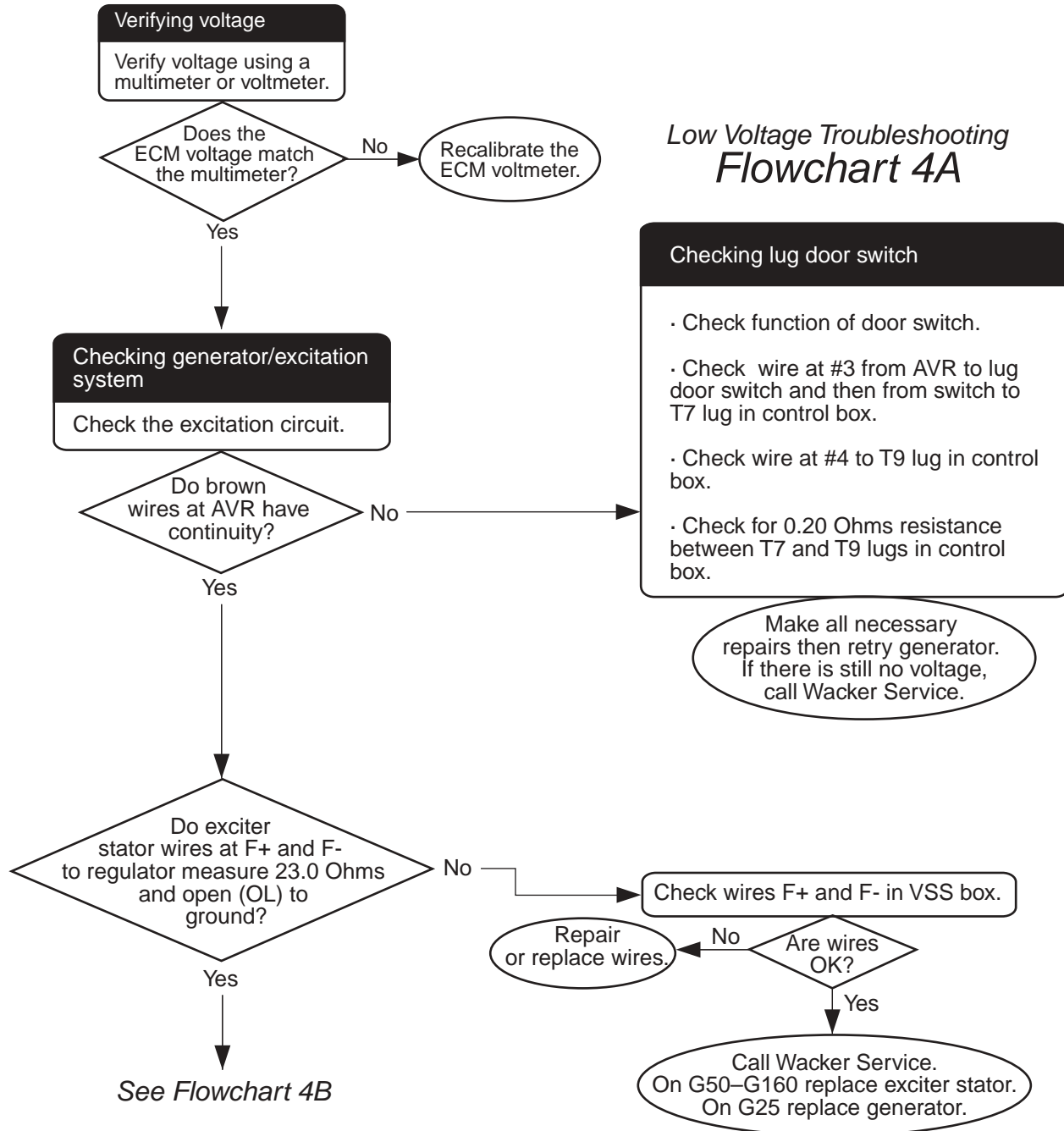

wc\_gr002859

Low Voltage Troubleshooting  
Flowchart 4C

Continued from Flowchart 4B

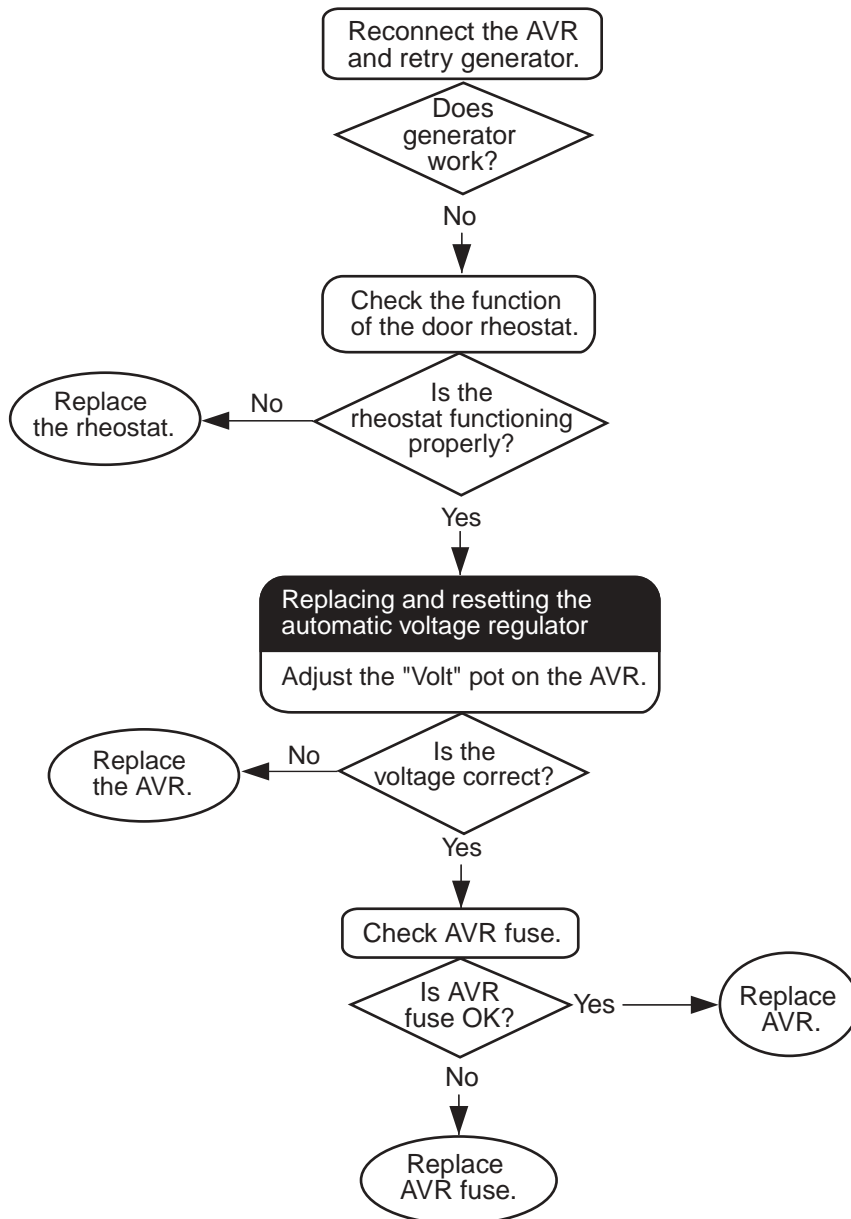

wc\_gr002860

Low Voltage Troubleshooting  
Flowchart 4B

Continued from Flowchart 4A

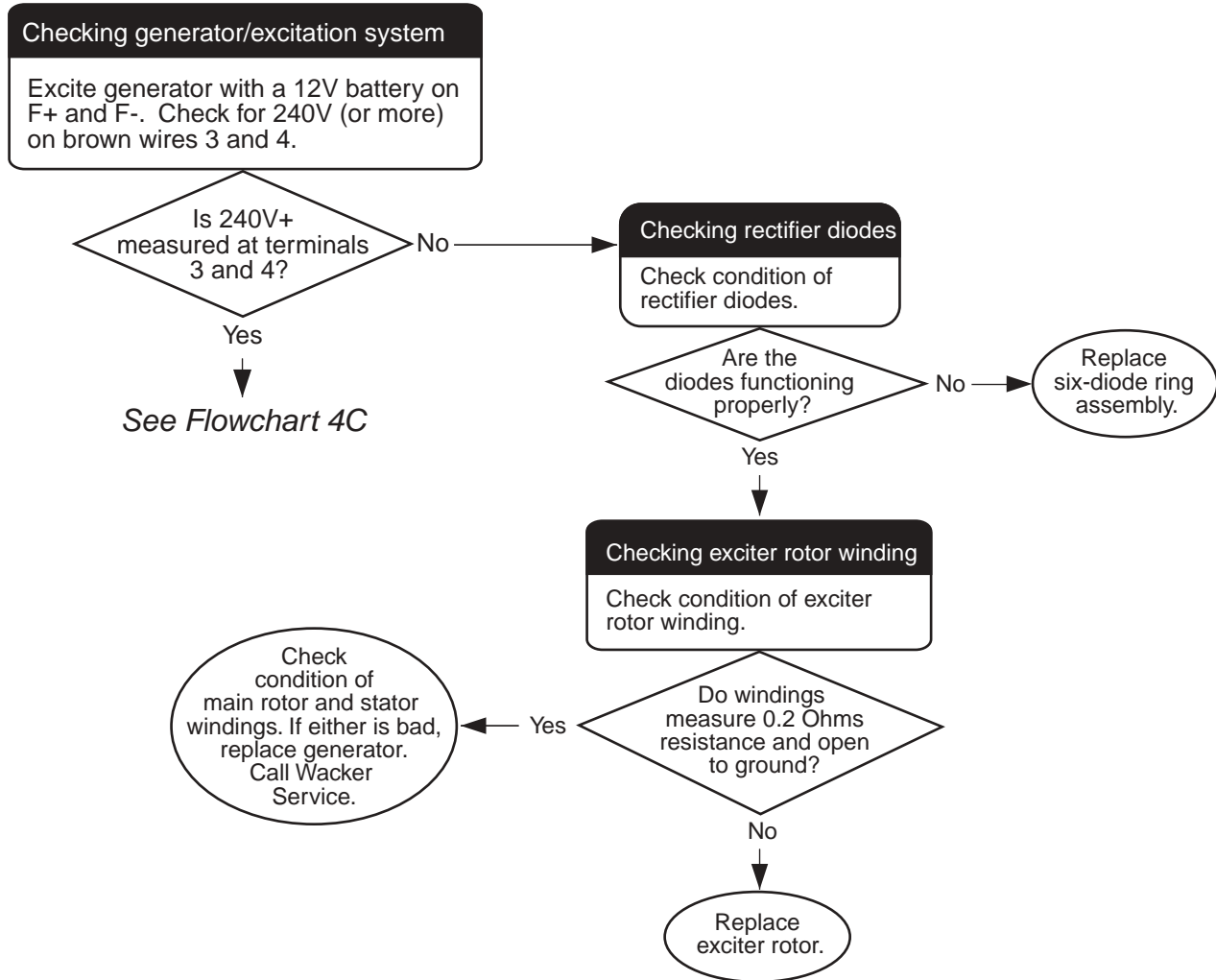

wc\_gr003009

## 9.16 Verifying Voltage

See Graphic: *wc\_gr001979*



Electric shock hazard. This test involves live voltages which can cause severe injury or death. Only qualified personnel should conduct this test.

- 9.16.1 Shut off the generator.
- 9.16.2 Open the lug door and defeat the interlock switch. To defeat the interlock switch, remove key latch from hinged door and place it in slot of interlock switch. See section *Checking Safety Interlock Switch*.
- 9.16.3 Start the generator.
- 9.16.4 Place the main circuit breaker in the "ON" (closed) position.
- 9.16.5 Using a personal voltmeter set to the 500V scale, measure voltage Lug 1 to Lug 2; Lug 2 to Lug 3; Lug 3 to Lug 1. Your readings should match those in the chart  $\pm 10\%$ .
- 9.16.6 If necessary, adjust the rheostat accordingly so that your readings do match.
- 9.16.7 Re-install the key latch when test is completed.**

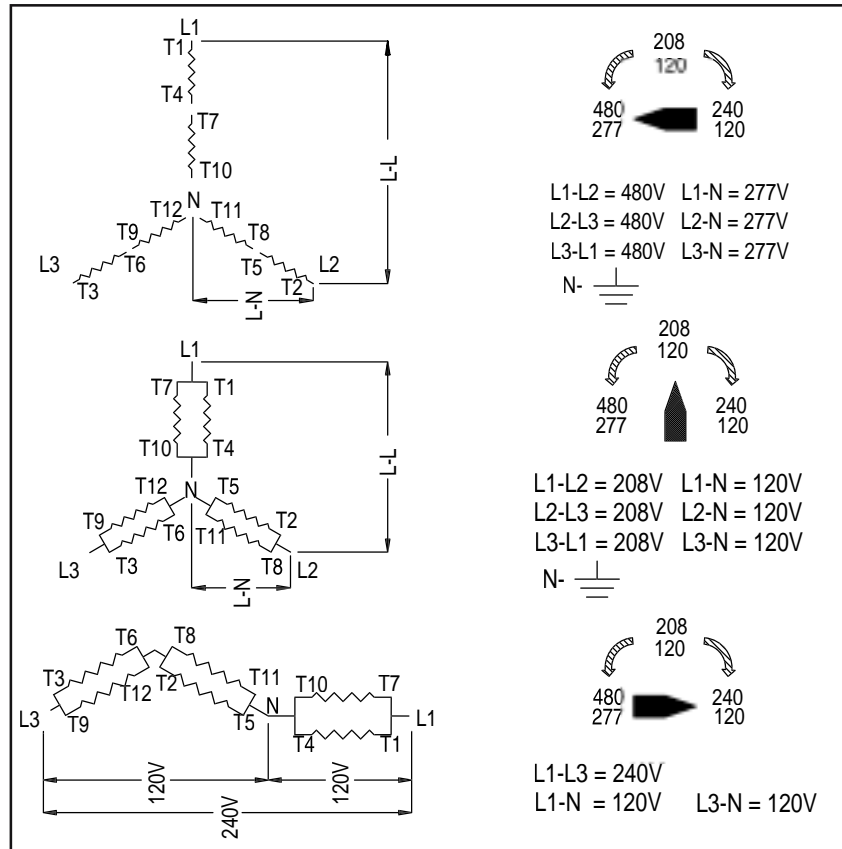

wc\_gr001979

## 9.17 Checking Main Stator Winding

See Graphic: *wc\_gr002108*

- 9.17.1 Remove the generator's rear enclosure panel.
- 9.17.2 Remove the top and rear covers of the voltage selector switch box.
- 9.17.3 Carefully label all wires (**a**) coming from inside the generator housing that are connected to the voltage selector switch. Disconnect the wires from the switch.  
**Note:** *These wires are recognizable by their cloth-type insulation. They also have metal bands attached with the appropriate wire number stamped on them.*
- 9.17.4 There are six coils that makeup the main stator winding, which are identified as: T1–T4, T2–T5, T3–T6, T7–T10, T8–T11, and T9–T12. Check each coil for continuity by measuring resistance across the appropriate wires disconnected in previous step. Each coil should measure the same, approximately 0.2 Ohms. If any of the coils does not measure 0.2 Ohms, replace the generator.  
Also check continuity between coils and coils to ground. There should be no path between coils. If you measure continuity between any coils, the coils have shorted together, therefore, replace the generator. If a reading to ground is less than 2 megohms, replace the generator.
- 9.17.5 Reconnect the wires if the main stator checks OK. Refer to the wiring diagram.

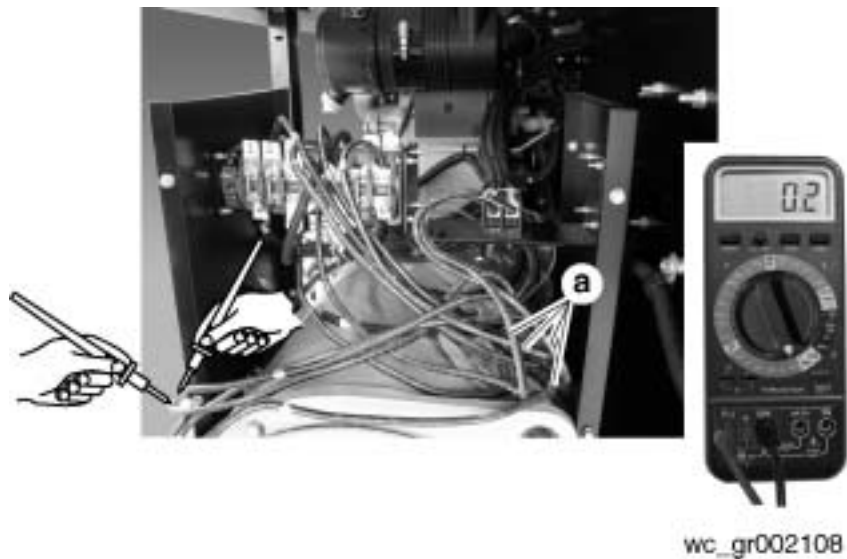

9.18 Generator Produces High Voltage Troubleshooting

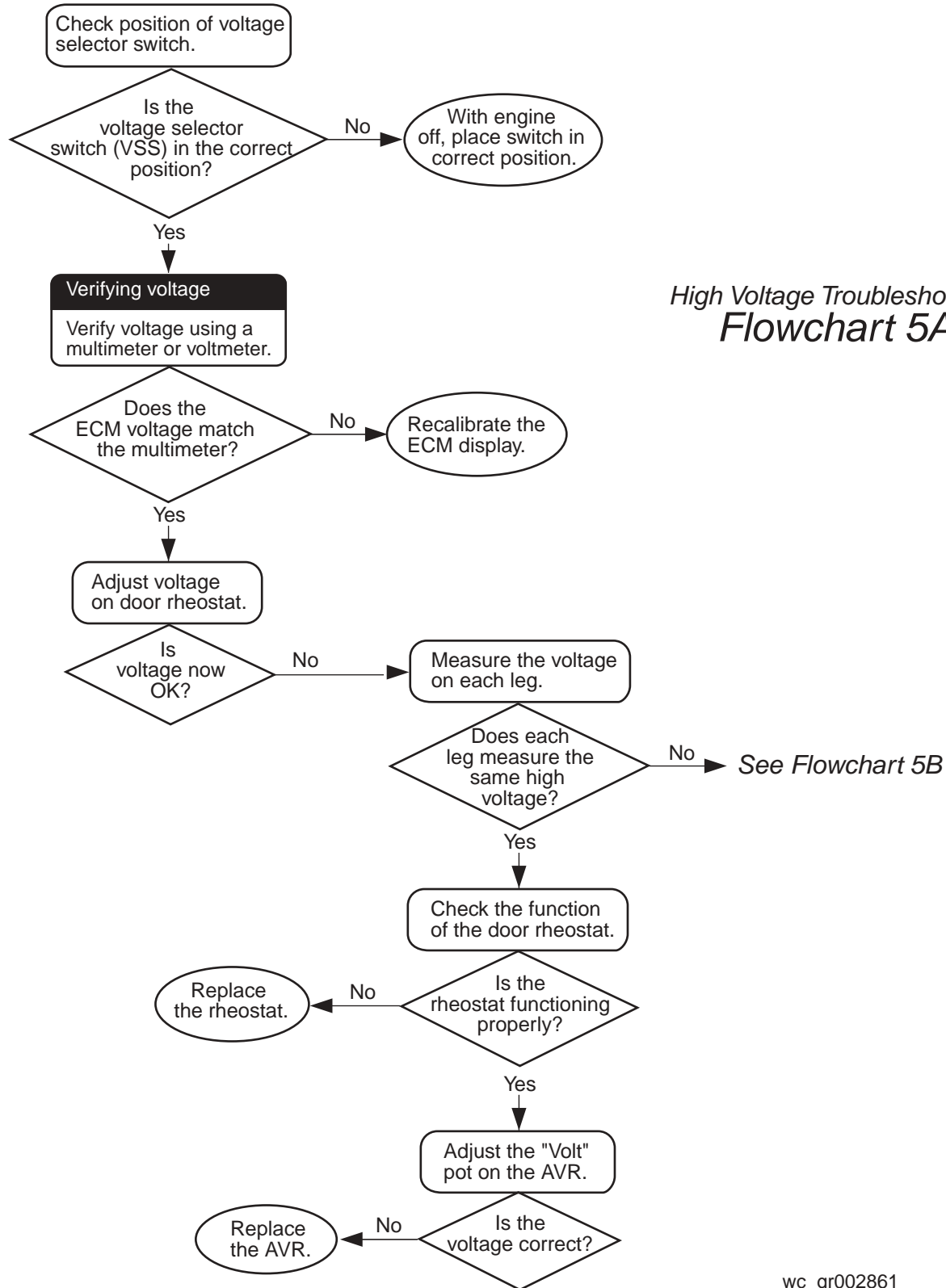

High Voltage Troubleshooting  
Flowchart 5A

wc\_gr002861

High Voltage Troubleshooting  
**Flowchart 5B**

Continued from Flowchart 5A

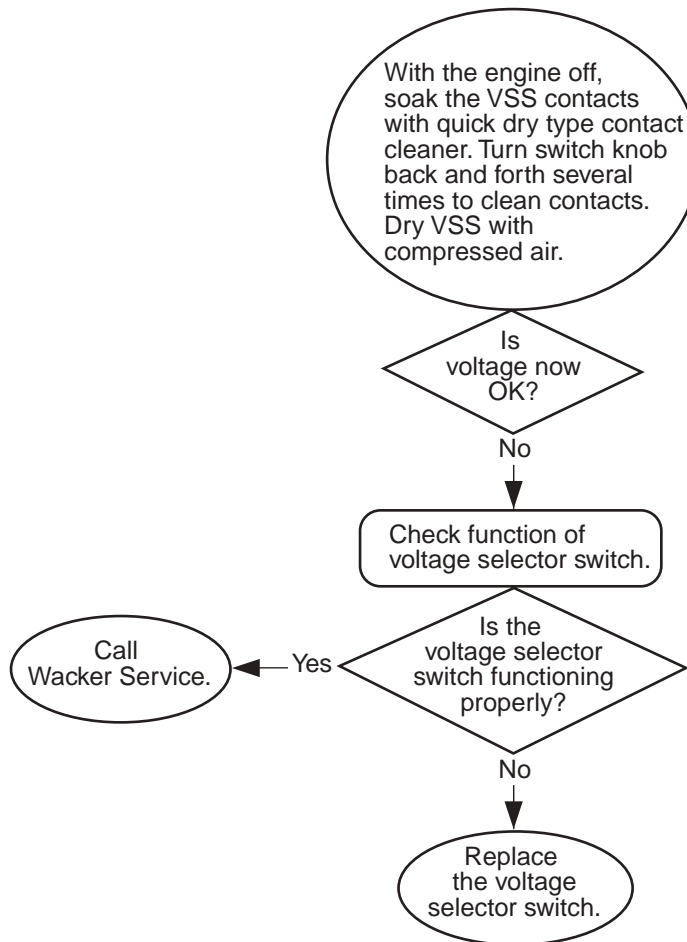

wc\_gr003010

## 9.19 Replacing Emergency Stop Switch

See Graphic: *wc\_gr002087*

Removal:

- 9.19.1 Remove the rear machine enclosure panel.
- 9.19.2 Remove the two screws **(a)** securing the protective cover **(b)**.
- 9.19.3 Disengage the switch connectors **(c)** from the nut **(e)**.
- 9.19.4 Loosen the two screws **(d)** securing the nut **(e)**. Then, twist and pull the nut to remove it.
- 9.19.5 Pull the knob assembly **(f)** from the panel.

Installation:

- 9.19.6 Insert the knob assembly **(f)** through the outer panel.
- 9.19.7 Secure the knob assembly to the panel by inserting the nut **(e)** over the knob assembly and twisting it. Then, tighten the two screws **(d)**.
- 9.19.8 Connect the switch connectors **(c)** to the nut **(e)**.
- 9.19.9 Secure the protective cover with two screws **(a)**.
- 9.19.10 Re-install the rear enclosure panel.

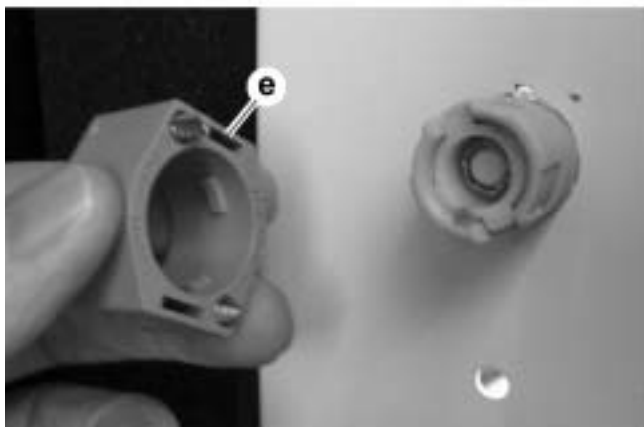
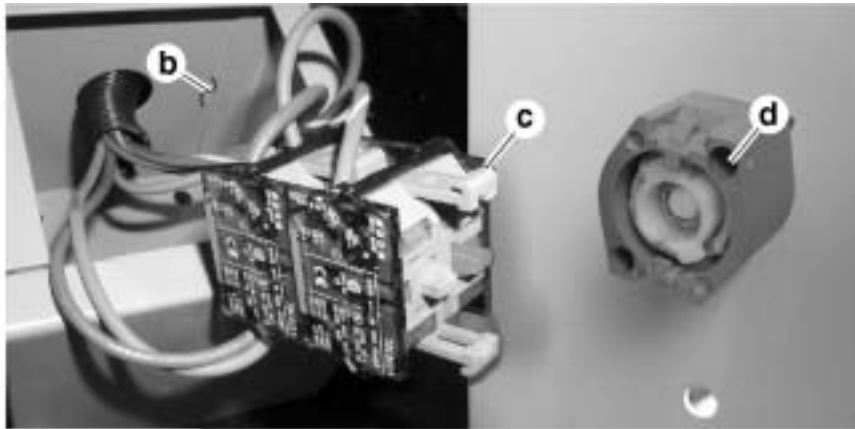
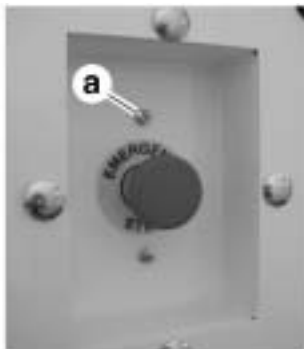

*wc\_gr002087*

**Notes**

## 10. Disassembly/Assembly Procedures

### 10.1 Tools

Because all possible problems encountered while repairing the equipment cannot be anticipated, it is up to the mechanic to use common sense and good judgement in tool selection.

The use of any special tools is recommended only for those operations where the use of conventional tools proves inadequate.

Before substituting another tool or procedure, you should be satisfied that neither personal injury nor damage to the component will result.

### 10.2 Ordering Parts

The repair procedures contained in this manual do not include part numbers. For parts replacement information, refer to the Parts Book originally supplied with the unit.

If the original Parts Book has been lost, a replacement may be ordered from Wacker Corporation. When ordering a replacement Parts Book, please list the model number, item number, revision level, and serial number of the machine. Parts Books are also available on the Wacker Corporation Web site. See [www.wackergroup.com](http://www.wackergroup.com). Enter the site as a visitor.

### 10.3 Reference Numbers ( )

Repair procedures contain reference numbers enclosed in parentheses ( ). These numbers refer to the item numbers shown on the assembly drawings and other detailed drawings. They are included to aid the mechanic in identifying parts and assembling components.

### 10.4 Weight Block

See Graphic: *wc\_gr000843*

The weight block symbol gives an approximate weight measurement to aid the mechanic when lifting/hoisting larger components.



wc\_gr000843

10.5 Exhaust System Exploded View—G 25

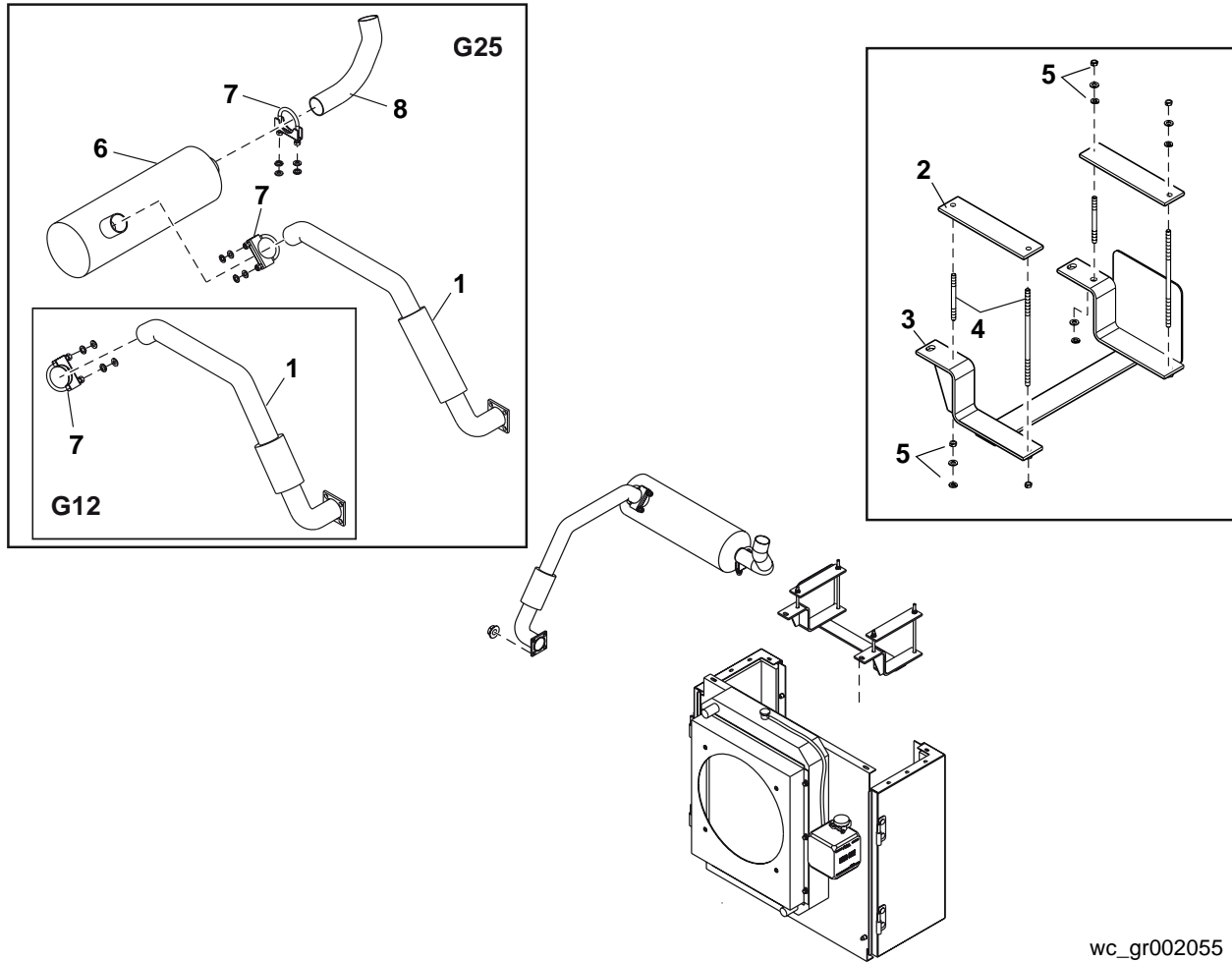

wc\_gr002055

Ref.	Component	Ref.	Component
1	Horizontal exhaust pipe	5	M8 hardware
2	Top muffler bracket	6	Muffler
3	Bottom muffler bracket	7	Clamp
4	Rod	8	Exhaust tail pipe

### 10.6 Removing Exhaust System—G 25

See Graphic: *wc\_gr002055*

- 10.6.1 Shut down the machine and allow the the exhaust pipes to cool.
- 10.6.2 Remove the front panel.
- 10.6.3 Disconnect the horizontal exhaust pipe (1) from the engine manifold.
- 10.6.4 Loosen the clamp securing the horizontal exhaust pipe to the muffler (6) and remove the horizontal exhaust pipe.
- 10.6.5 Remove the screws securing the muffler bracket (3) to the radiator bulkhead and remove the bracket and the muffler as an assembly.
- 10.6.6 Loosen the U-bolts or clamps securing the muffler to the bracket and remove the muffler from the bracket.

### 10.7 Installing Exhaust System—G 25

See Graphic: *wc\_gr002055*

- 10.7.1 Secure the muffler bracket to the radiator bulkhead.
- 10.7.2 Temporarily mount the muffler (6) to the muffler bracket using U-bolts or rods. Do not tighten the hardware.
- 10.7.3 Insert the horizontal pipe (1) into the muffler but do not tighten the clamp.
- 10.7.4 Secure the other end of the horizontal exhaust pipe to the engine manifold.
- 10.7.5 Secure the horizontal exhaust pipe to the muffler by tightening the clamp.
- 10.7.6 Attach the tail pipe (8) to the muffler before tightening the clamp. Position the tail pipe so that exhaust is emitted up and out of the enclosure.
- 10.7.7 Tighten the clamps securing the muffler to the muffler bracket.
- 10.7.8 Re-install the front panel.

**10.8 Exhaust System Exploded View—G 50, G 70, G 85**

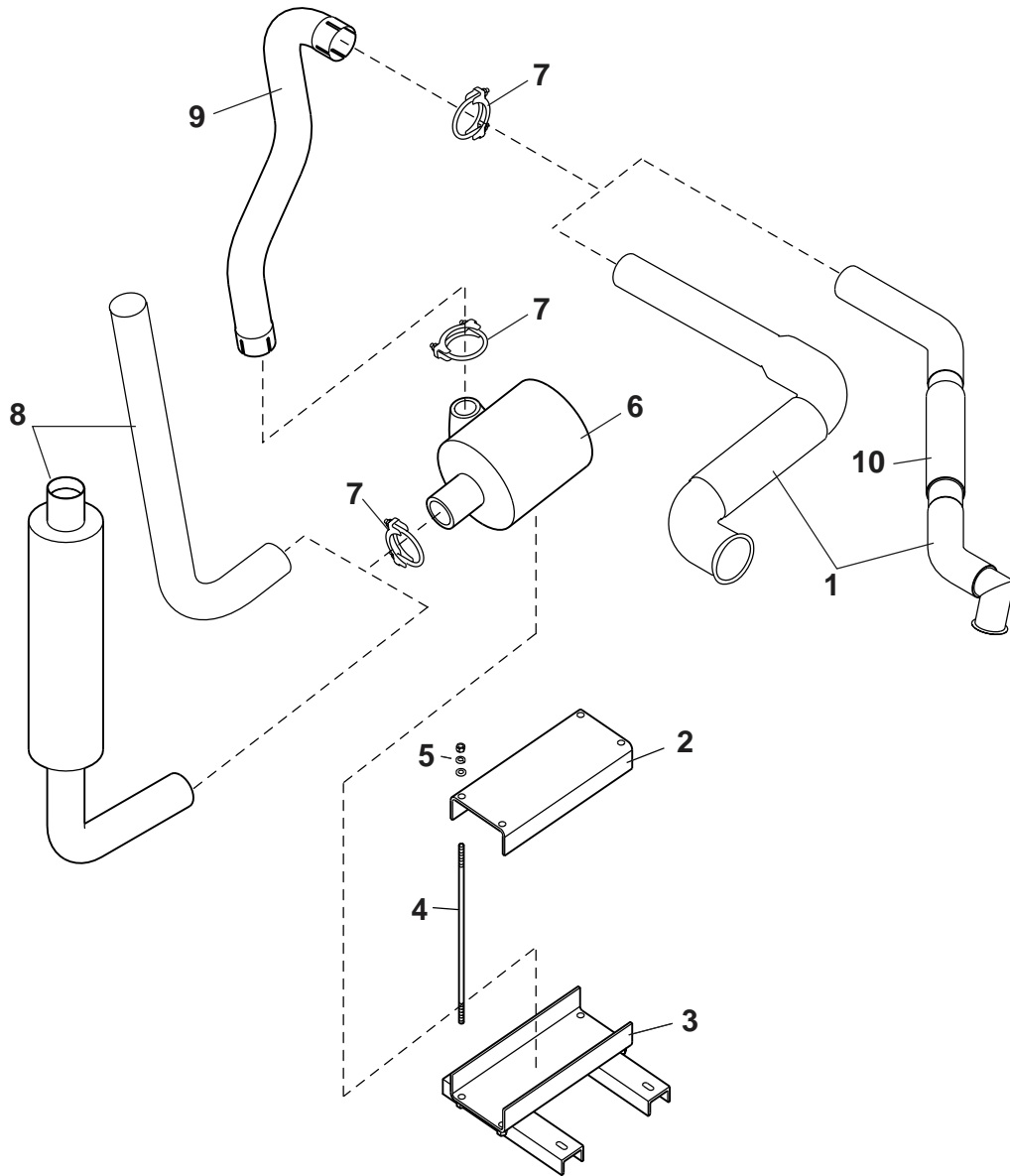

wc\_gr002041

Ref.	Component	Ref.	Component
1	Horizontal exhaust pipe	6	Muffler
2	Top muffler bracket	7	Clamp
3	Bottom muffler bracket	8	Exhaust tail pipe
4	Rod	9	Vertical exhaust pipe
5	M8 hardware	10	Heat wrap

## 10.9 Removing Exhaust System—G 50, G 70, G 85

See Graphic: *wc\_gr002041* and *wc\_gr002042*

- 10.9.1 Shut down the machine and allow the exhaust pipes to cool.
- 10.9.2 Remove the front panel.
- 10.9.3 Remove the clamp **(a)** securing the horizontal exhaust pipe **(b)** to the engine exhaust manifold.
- 10.9.4 Loosen the clamp **(c)** securing the horizontal exhaust pipe to the vertical exhaust pipe **(d)**.
- 10.9.5 Remove the M8 hardware **(e)** securing the muffler brackets and remove the upper muffler bracket **(f)**.
- 10.9.6 Rotate the muffler **(g)** to allow the exhaust pipes to be separated and remove the horizontal exhaust pipe.
- 10.9.7 Loosen the clamp securing the vertical exhaust pipe **(h)** to the muffler and remove the vertical pipe.
- 10.9.8 Remove the muffler and the exhaust tail pipe **(i)** as an assembly. Once out of the generator, remove the exhaust tail pipe from the muffler.

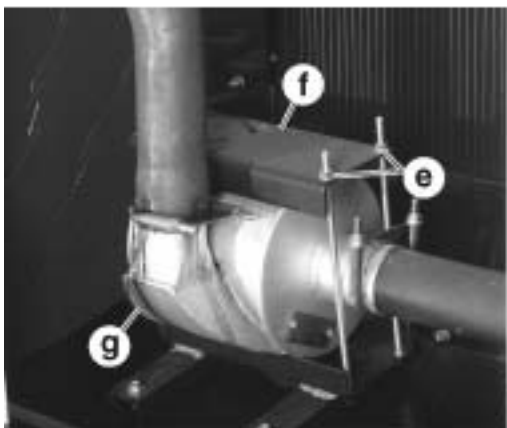
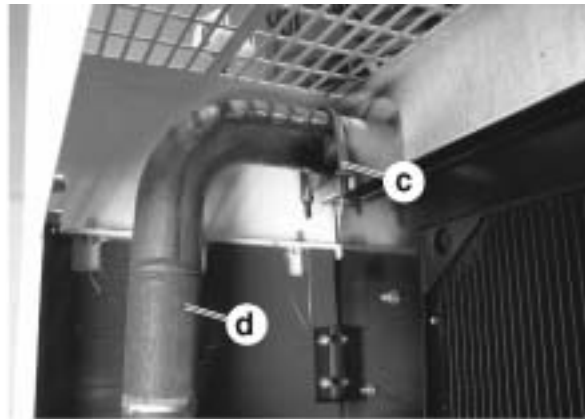
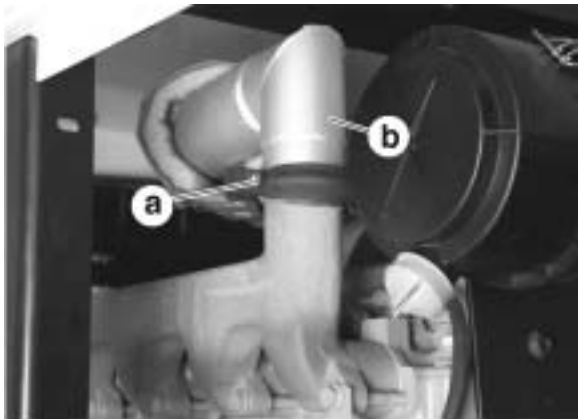

wc\_gr002042

### 10.10 Installing Exhaust System—G 50, G 70, G 85

*See Graphic: wc\_gr002042*

- 10.10.1 Position the horizontal exhaust pipe **(b)** in the engine exhaust manifold, then across the top of the engine and out the rear of the enclosure.
- 10.10.2 Position the muffler **(g)** in the lower muffler bracket.
- 10.10.3 Slide the clamp over the vertical exhaust pipe and insert the vertical exhaust pipe **(h)** into the horizontal exhaust pipe. Insert the opposite end of the vertical exhaust pipe into the muffler.
- 10.10.4 Insert the exhaust tail pipe **(i)** into the muffler **(g)**.
- 10.10.5 Rotate the muffler as necessary to position the exhaust tail pipe up and out of the enclosure.
- 10.10.6 Secure the horizontal exhaust pipe with the clamp **(a)**. Secure all other exhaust pipes with the appropriate clamps.
- 10.10.7 Secure the muffler with the upper and lower muffler brackets using rods and M8 hardware.
- 10.10.8 Re-install the front panel.

## 10.11 Exhaust System Exploded View—G 125, G 160

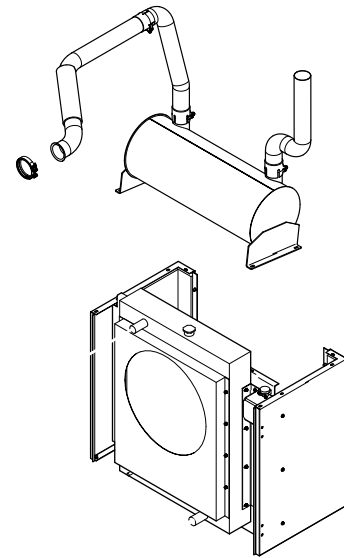
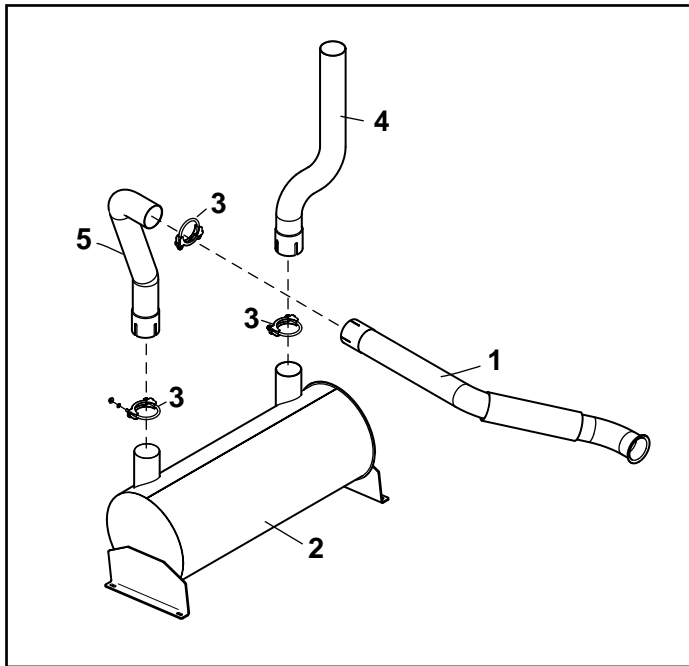

wc\_gr002056

Ref.	Component	Ref.	Component
1	Horizontal exhaust pipe	4	Exhaust tail pipe
2	Muffler	5	Vertical exhaust pipe
3	Clamp		

## 10.12 Removing Exhaust System—G 125, G 160

See Graphic: *wc\_gr002056*

- 10.12.1 Shut down the machine and allow the exhaust pipes to cool.
- 10.12.2 Remove the front panel.
- 10.12.3 Loosen the clamp securing the horizontal exhaust pipe (1) to the exhaust manifold.
- 10.12.4 Loosen the clamp securing the horizontal exhaust pipe to the vertical exhaust pipe (5) and remove the horizontal exhaust pipe.
- 10.12.5 Loosen the clamp securing the vertical exhaust pipe to the muffler (2) and remove the vertical exhaust pipe.
- 10.12.6 Loosen the clamp securing the exhaust tail pipe (4) to the muffler and remove the exhaust tail pipe.
- 10.12.7 Remove the hardware securing the muffler and remove the muffler.

### **10.13 Installing Exhaust System—G 125, G 160**

*See Graphic: wc\_gr002056*

- 10.13.1 Position the muffler (2) in place but do not tighten the hardware.
- 10.13.2 Secure the exhaust tail pipe (4) to the muffler using the clamp.
- 10.13.3 Position the vertical exhaust pipe (5) and the clamp on the muffler but do not tighten the clamp.
- 10.13.4 Secure the horizontal exhaust pipe (1) to the engine manifold.
- 10.13.5 Secure the horizontal exhaust pipe to the vertical exhaust pipe with the clamp.
- 10.13.6 Tighten all clamps.
- 10.13.7 Secure the muffler to the unit.
- 10.13.8 Re-install the front panel.

## 10.14 Preparing Unit for Generator Removal

See Graphic: *wc\_gr002043*

- 10.14.1 Disconnect the battery.
- 10.14.2 Remove the doors. To remove the doors, simply pull up on the door at the hinge.
- 10.14.3 Remove the screws securing the rear panel and remove the panel.
- 10.14.4 Remove the fill hose **(a)** and the vent hose **(d)** from inside the engine compartment. Plug the fuel tank opening.
- 10.14.5 Remove the ground strap **(b)**.
- 10.14.6 Remove the top of the voltage selector switch box and the rear panel.
- 10.14.7 Carefully label the terminals and the outgoing wires of the selector switch, then remove the wires. Refer to the wiring schematic.
- 10.14.8 Support the engine using appropriate jacks **(c)**.
- 10.14.9 Support the generator with a fork lift, engine stand, or other appropriate lifting device.

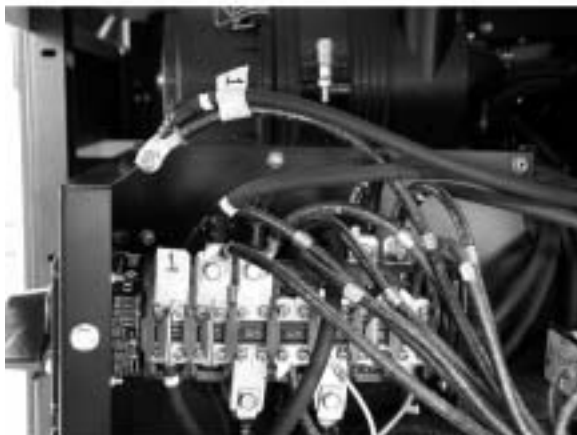
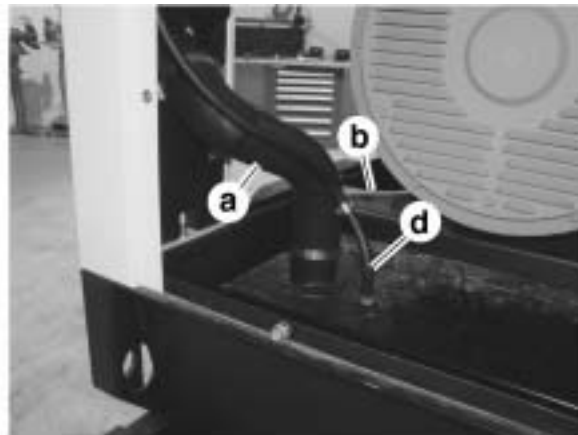

wc\_gr002043

10.15 Removing Generator

See Graphic: wc\_gr002044

- 10.15.1 On John Deere-powered machines, remove the nuts **(a)** securing the generator to the two shock mounts. On Isuzu-powered machines, remove the nuts **(f)** securing the generator to the mounting plate. (Remove the mounting plate after the generator has been removed.)
- 10.15.2 Remove the fan guard **(b)**.
- 10.15.3 Remove the bolts securing the rotor drive plates **(c)** to the engine flywheel **(d)**. The bolts are accessed through the fan exhaust opening in the generator housing. It will be necessary to turn the engine flywheel to access all of them.
- 10.15.4 Remove the bolts **(e)** securing the generator stator housing to the engine adapter flange. It may be necessary to use an obstruction (curved) wrench to access the bolts.
- 10.15.5 If necessary for clearance, remove the voltage selector switch knob.
- 10.15.6 Using an appropriate hoist or lifting device, carefully lift the generator up and off the shock mounts and pull the generator from the rear of the machine.



	lbs.	kg
G12	250	113
G25	275	125
G50	569	258
G70	620	281
G85	706	320
G110	798	361
G125	798	361
G155	943	428
G160	943	428



wc\_gr002044

## 10.16 Installing Generator

See Graphic: *wc\_gr002049*

- 10.16.1 To aid in assembly, insert two M10 guide studs into two of the engine adapter flange holes **(a)**. Isuzu engines already have these studs **(e)**.
- 10.16.2 Using an appropriate hoist or lifting device, carefully position the generator on the guide studs and shock mounts **(b)**.
- 10.16.3 Secure the rotor drive plates to the engine flywheel using six 3/8-inch bolts. The bolts are accessed through the fan exhaust opening in the generator housing. It will be necessary to turn the engine flywheel to access all of them. Be sure the rotor drive plates are seated flush inside the engine flywheel, then torque the bolts, in a star pattern, to 22 ft.lbs. (31 Nm).
- 10.16.4 Secure the generator housing to the engine using twelve M10 bolts **(c)**. Remove the M10 guide studs installed in step 1. It may be necessary to use an obstruction (curved) wrench to access the bolts. Torque the bolts to 36 ft.lbs. (49 Nm).
- 10.16.5 Re-install the fan guard **(d)**.
- 10.16.6 Re-install the nuts securing the generator to the two shock mounts. Torque the nuts per the torque specification chart.
- 10.16.7 Re-install all items removed or disconnected in section *Preparing Unit for Generator Removal*.

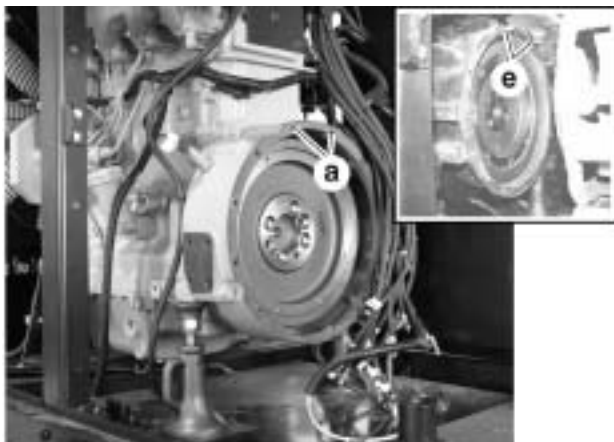

	lbs.	kg
G12	250	113
G25	275	125
G50	569	258
G70	620	281
G85	706	320
G110	796	361
G125	796	361
G155	943	428
G160	943	428



wc\_gr002049

## 10.17 Removing Roof and Center Support Brackets

See Graphic: *wc\_gr002046*

- 10.17.1 With an appropriate hoist or lifting device, support the roof of the generator by the lifting eye.
- 10.17.2 Remove the bolts **(a)** securing the roof to the sides. Also remove the bolts **(b)** securing the top to the radiator bulkhead.
- 10.17.3 Remove the bolts **(c)** securing the control panel **(d)** to the upright brace **(e)**.
- 10.17.4 Remove the bolts **(f)** securing the upright braces to the frame.
- 10.17.5 With the assistance of a partner, lift the roof and support brackets, as an assembly, up and off the trailer frame.

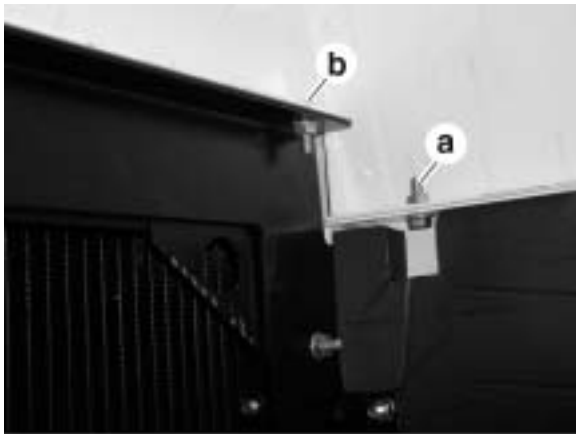

wc\_gr002046



### 10.18 Installing Roof and Center Support Brackets

*See Graphic: wc\_gr002046*

- 10.18.1 With an appropriate hoist or lifting device, support the roof of the generator by the lifting eye.
- 10.18.2 With the assistance of a partner, position the top on the unit.
- 10.18.3 Install the bolts **(f)** securing the upright braces to the frame.
- 10.18.4 Install the bolts **(c)** securing the control panel **(d)** to the upright brace **(e)**.
- 10.18.5 Install the bolts **(a)** securing the top to the sides. Also install the bolts **(b)** securing the top to the radiator bulkhead.

### 10.19 Preparing Unit for Engine/Generator Removal

See Graphic: *wc\_gr002045*

- 10.19.1 Disconnect the battery.
- 10.19.2 Remove the doors. To remove the doors, simply pull up on the door at the hinge.
- 10.19.3 Remove the screws securing the front and rear panels and remove the panels.
- 10.19.4 Remove the roof. See section *Removing Roof*.
- 10.19.5 Remove the horizontal exhaust pipe running from the exhaust manifold to the rear of the unit. See section *Removing Exhaust System*.
- 10.19.6 Drain the coolant from the engine. Disconnect the hoses from between the engine and the radiator.
- 10.19.7 Remove the fan guard **(a)**.
- 10.19.8 Disconnect the bracket **(b)** holding the crankcase vent filter from the horizontal support member.
- 10.19.9 Remove the fuel fill hose **(c)** and the tank vent hose **(d)** from inside the engine compartment. Plug the fuel tank opening.
- 10.19.10 Disconnect both the fuel supply hose **(i)** and the fuel return hose **(j)** from the engine and plug the hoses.
- 10.19.11 Check the engine for the lifting eyes **(e or f)**. Add a lifting eye if necessary.
- 10.19.12 Remove the ground straps from the engine and the generator .
- 10.19.13 Remove the top of the voltage selector switch box and the rear panel.
- 10.19.14 Carefully label the terminals and the outgoing wires **(g)** of the selector switch, then remove the wires. Refer to the wiring schematic.
- 10.19.15 Disconnect the wiring harness **(h)** from the engine. Refer to the wiring schematic. Check for any other wiring between the engine and the unit; label the wiring and disconnect as necessary.

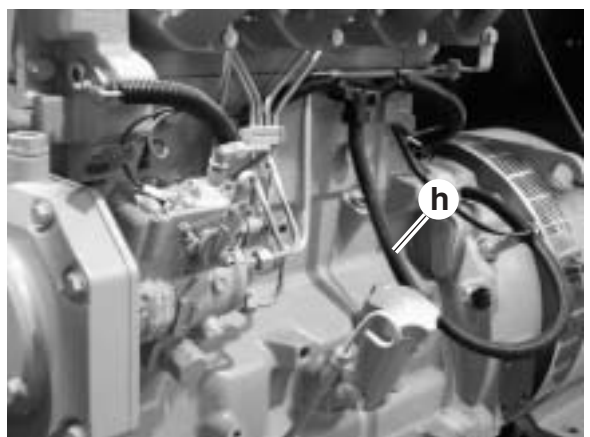
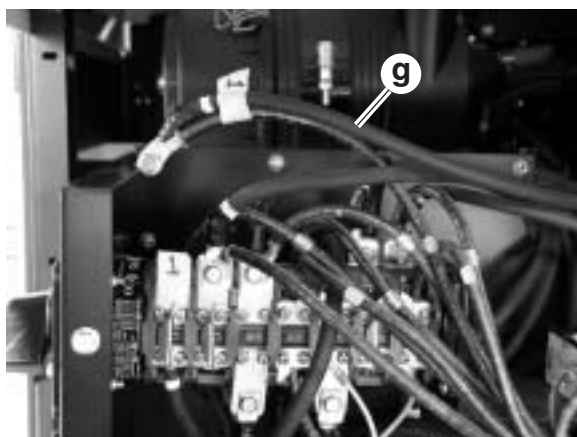
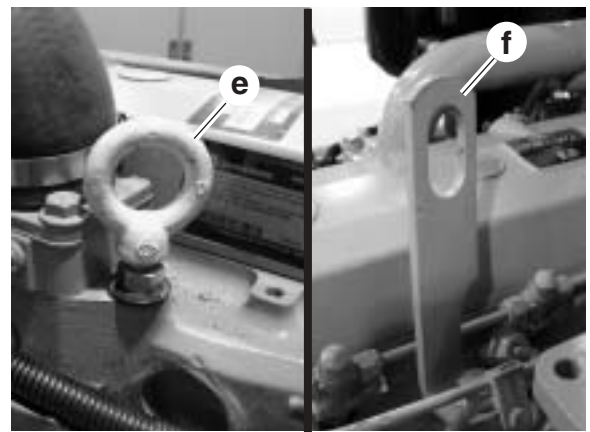
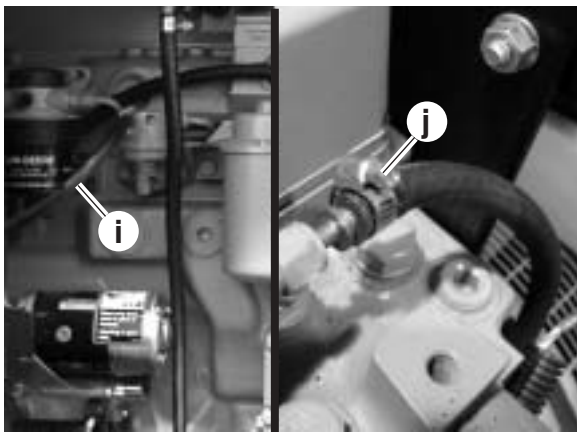
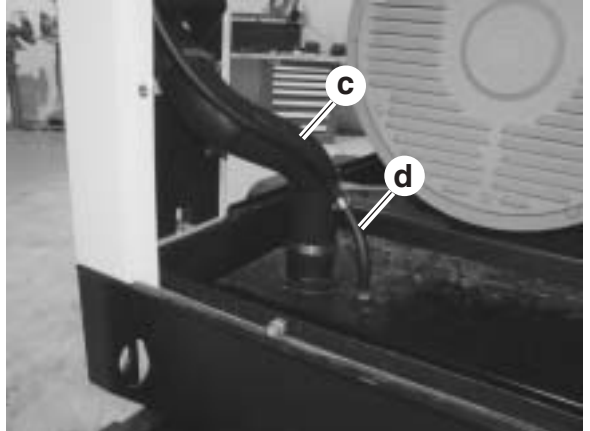
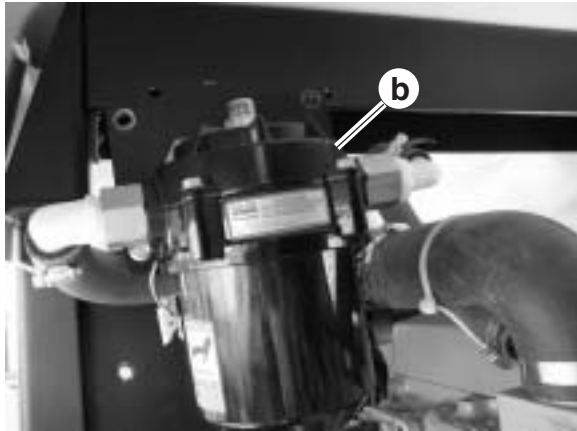
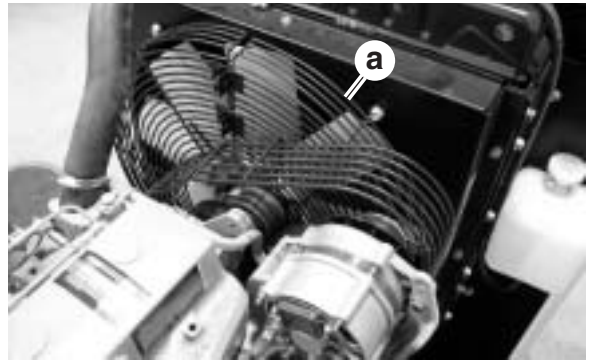

wc\_gr002045

10.20 Removing Engine/Generator Assembly

See Graphic: wc\_gr002047

- 10.20.1 Using chains attached to the lifting eyes of the engine (a) and the generator (b), support the engine/generator assembly with an appropriate hoist or lifting device.
- 10.20.2 Remove the screws (c) securing the engine to the engine mounts.
- 10.20.3 Remove the nuts (d) securing the generator to the shock mounts.
- 10.20.4 With the assistance of a partner, carefully lift the engine/generator assembly up and out of the unit.

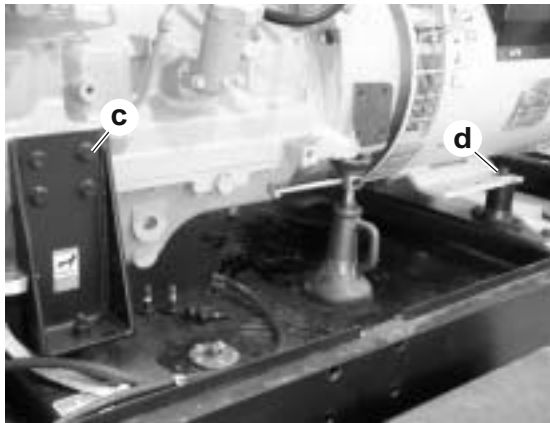
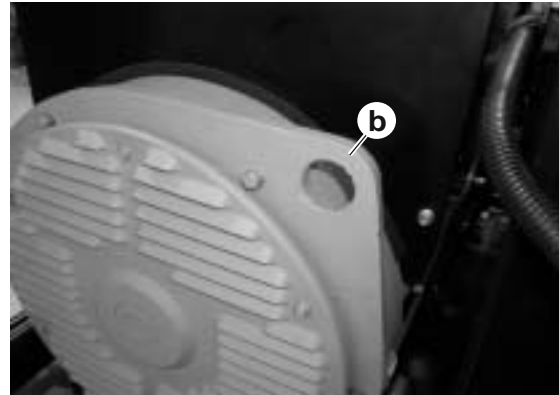
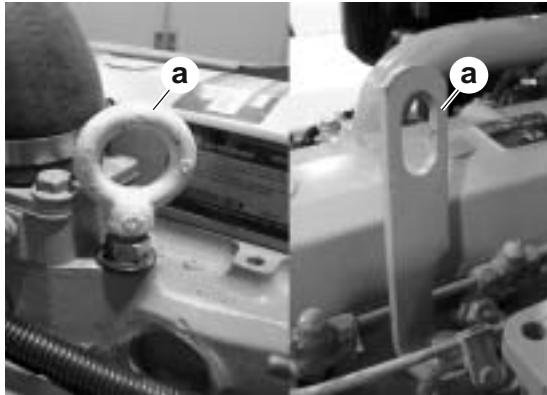

	lbs.	kg
G12	541	245
G25	664	301
G50	1420	644
G70	1492	677
G85	1578	716
G110	1968	893
G125	1968	893
G155	2563	1163
G160	2563	1163



wc\_gr002047

### 10.21 Installing Engine/Generator Assembly

See Graphic: *wc\_gr002047*

- 10.21.1 Using chains attached to the lifting eyes of the engine **(a)** and the generator **(b)**, support the engine/generator assembly with an appropriate hoist or lifting device.
- 10.21.2 With the assistance of a partner, carefully position the engine/generator assembly on the unit.
- 10.21.3 Secure the engine to the engine mounts using eight M12 bolts **(c)**. Torque bolts to 63 ft.lbs. (86 Nm).
- 10.21.4 Install the nuts **(d)** securing the generator to the shock mounts. Torque the nuts per the torque specification chart.
- 10.21.5 Re-install all items removed or disconnected in section *Preparing Unit for Engine/Generator Removal*.

## 10.22 Replacing Fuel Tank

See Graphic: *wc\_gr002125*

### Removal:

- 10.22.1 Remove the four M16 bolts **(a)** and nuts securing the skid to the trailer. Using an appropriate lift or hoist, lift the generator/fuel tank assembly from the trailer.
- 10.22.2 Remove the front and rear enclosure panels for access to bolts. Remove the M8 bolts **(b)** securing the drip pan **(c)** to the skid and remove the pan. Set the generator/fuel tank assembly on 4 x 4 beams.
- 10.22.3 Disconnect the fuel hoses **(d)** and the the fuel sender wiring **(e)**.
- 10.22.4 Remove the four M12 bolts **(f)** securing the fuel tank **(g)** to the skid frame cross members. Using an appropriate lift or hoist, lift the generator/fuel tank assembly from the trailer.

### Installation:

- 10.22.5 Suspend the generator assembly over the tank **(g)**, lower the generator over the tank, and secure the tank to the skid frame with four M12 bolts **(f)**. Torque the bolts per the torque specification chart.
- 10.22.6 Raise the generator/fuel tank assembly. Secure the drip pan **(c)** to the skid frame using the M8 bolts **(b)**. Torque the bolts per the torque specification chart.
- 10.22.7 Reconnect the fuel hoses **(d)** and the fuel sender wiring **(e)**.
- 10.22.8 Secure the skid to the trailer using four M16 bolts **(a)** and nuts. Torque the bolts per the torque specification chart.

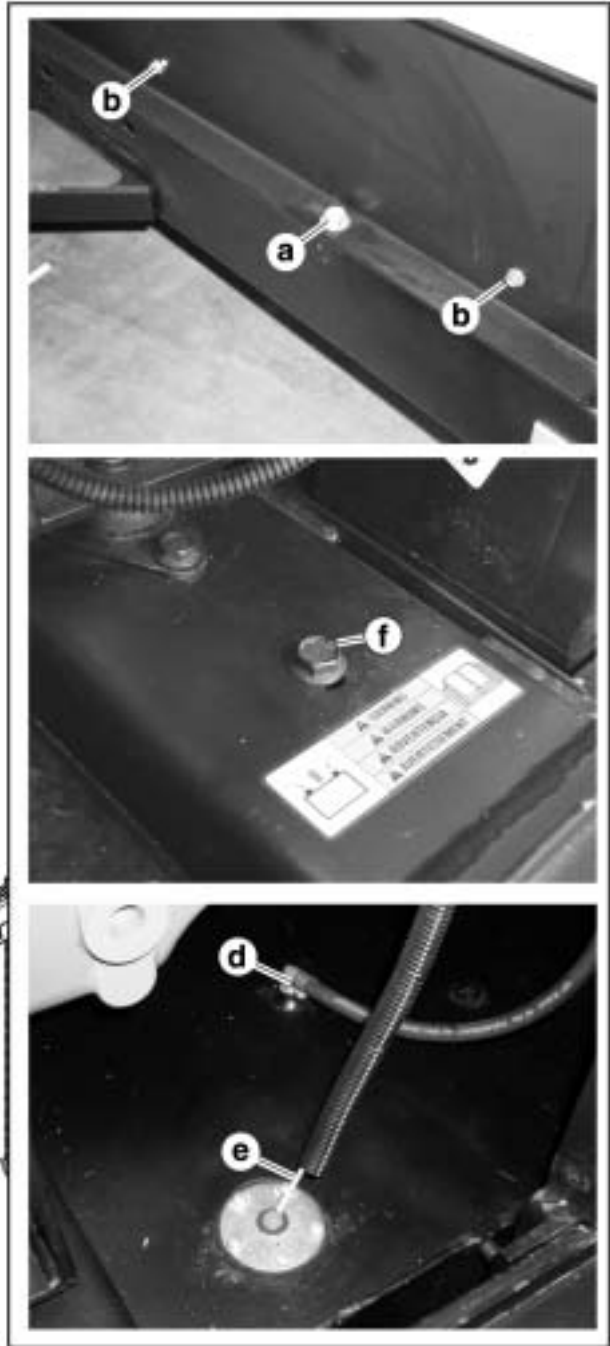
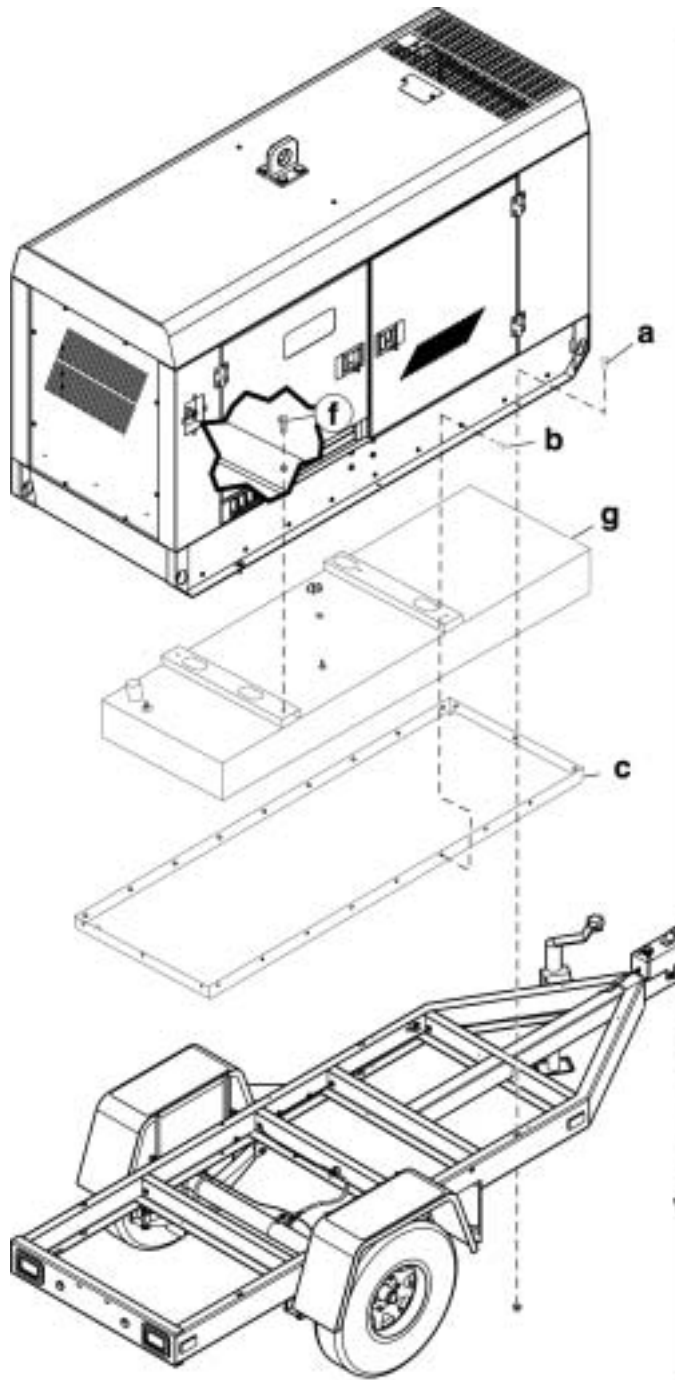

wc\_gr002125

## 11. Factory-Installed Options

This machine may be equipped with one or more of the following factory-installed options. To verify if any of these options are installed on your machine, contact the WACKER Corporation at 1-800-770-0957. A nameplate listing the Model Number, Item Number, Revision, and Serial Number is attached to each unit. Please have this information available when contacting WACKER Corporation.

### 11.1 Block Heater

See Graphic: *wc\_gr001709*

The engine block heater option includes a block heater **(a)** with a cord **(b)**. The function of the block heater is to heat the engine coolant/engine block to improve cold-weather engine starting. Plug the cord into a 120V power supply.

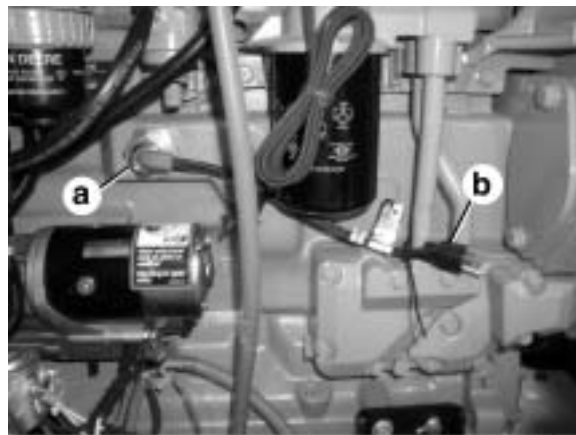

wc\_gr001709

## 11.2 Fuel/Water Separator

See Graphic: *wc\_gr001705*

The fuel/water separator separates water from the fuel on models with Isuzu engines. Empty the separator water bowl (**a**) as needed by opening the water bowl drain (**b**). The separator element should be changed each time the fuel filter is changed—approximately every 600 hours of operation.

To change the element:

- 11.2.1 Loosen the element retainer (**d**) and remove the retainer and element (**c**) from the separator head.
- 11.2.2 Unscrew the water bowl from the element.



### 11.3 Electronic Governor

See *Graphic: wc\_gr001714, wc\_gr001715, wc\_gr001716, wc\_gr001717*

The electronic governor option consists of an electronic module (**a** or **b**) and an electronic actuator (**c** or **d**). The module senses rotation of the flywheel, then sends a signal to the electronic actuator that governs the fuel injection system. The system is designed to precisely regulate engine rpm, and thus frequency, to within approximately 0.25%. See electronic governor manufacturer's literature for detailed information.

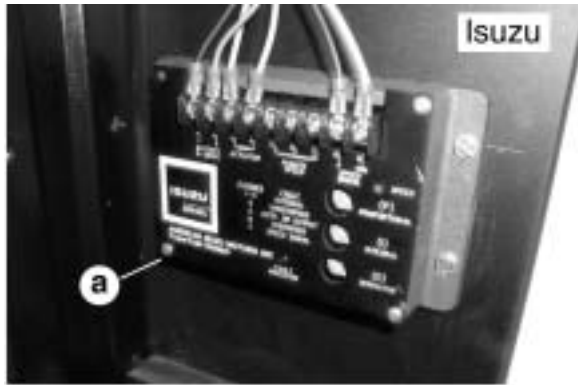

wc\_gr001715

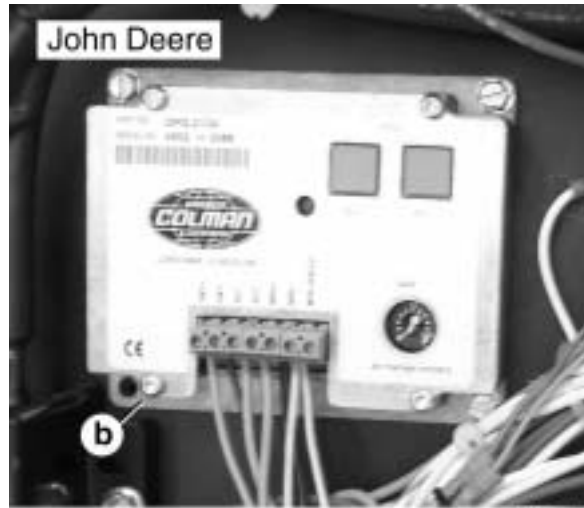

wc\_gr001716



wc\_gr001717

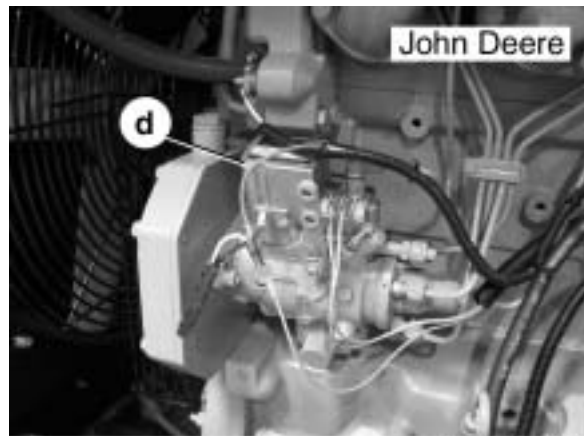

wc\_gr001714

11.4 Schematic—Isuzu Engine with Electronic Governor

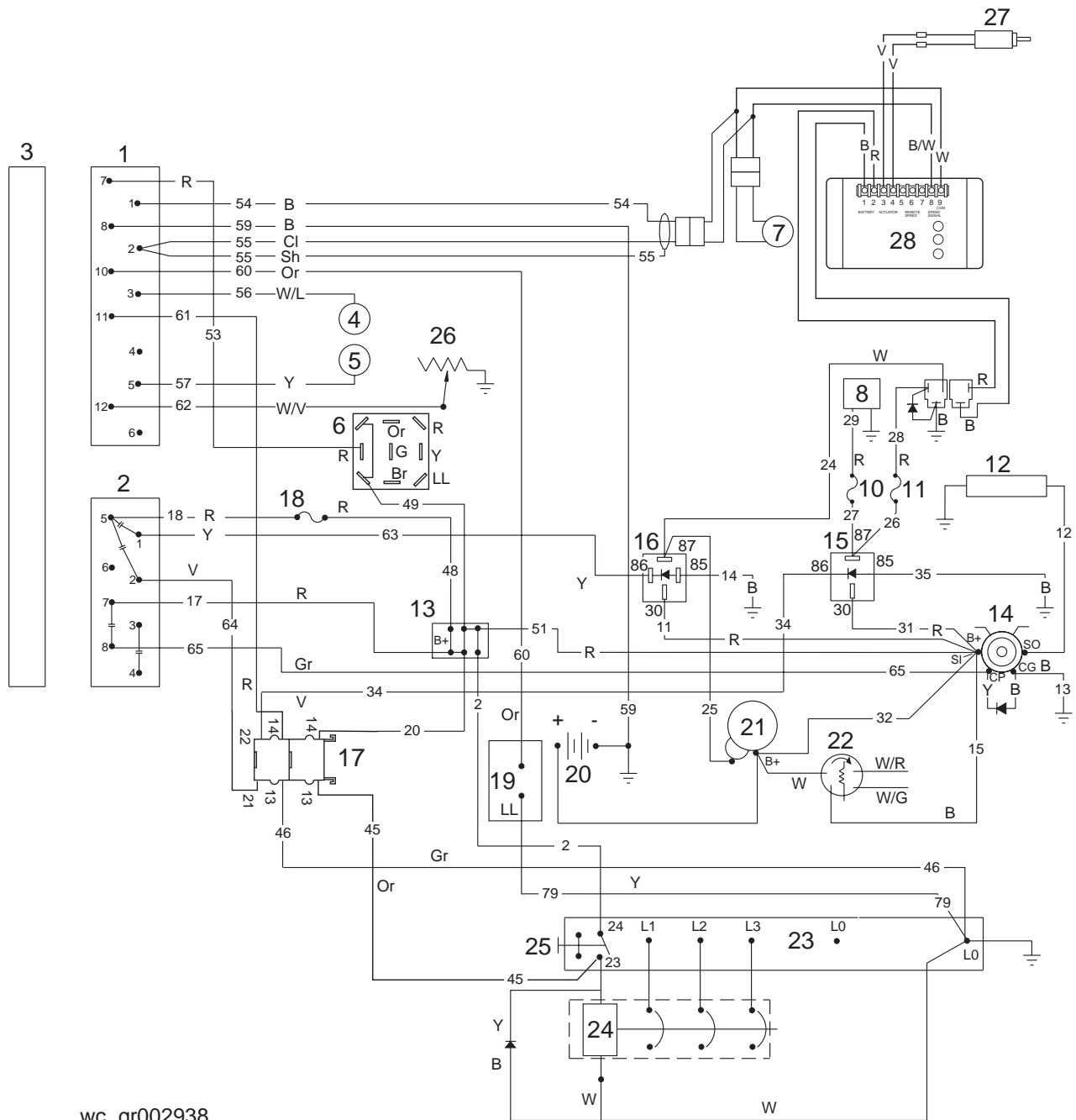

**11.5 Components—Isuzu Engine with Electronic Governor**

Ref.	Component	Ref.	Component
1	Plug 1 - engine sender inputs	15	Fuel relay
2	Plug 2 - engine start outputs	16	Starter relay
3	Engine control module	17	Emergency stop switch
4	Oil pressure sender	18	10A fuse #1
5	Water temperature sender	19	Remote start terminals
6	Remote Start - Off - Start/Run switch	20	Battery
7	Magnetic pickup	21	Starter motor
8	Fuel pump	22	Alternator
9	---	23	Mechanical lugs
10	10A fuse #2	24	Main circuit breaker - shunt trip
11	10A fuse #3	25	Lug door interlock switch
12	Glow plugs	26	Fuel level sender
13	B+ terminal block	27	Actuator
14	Glow plug relay	28	Electronic governor

11.6 Schematic—John Deere Engine with Electronic Governor

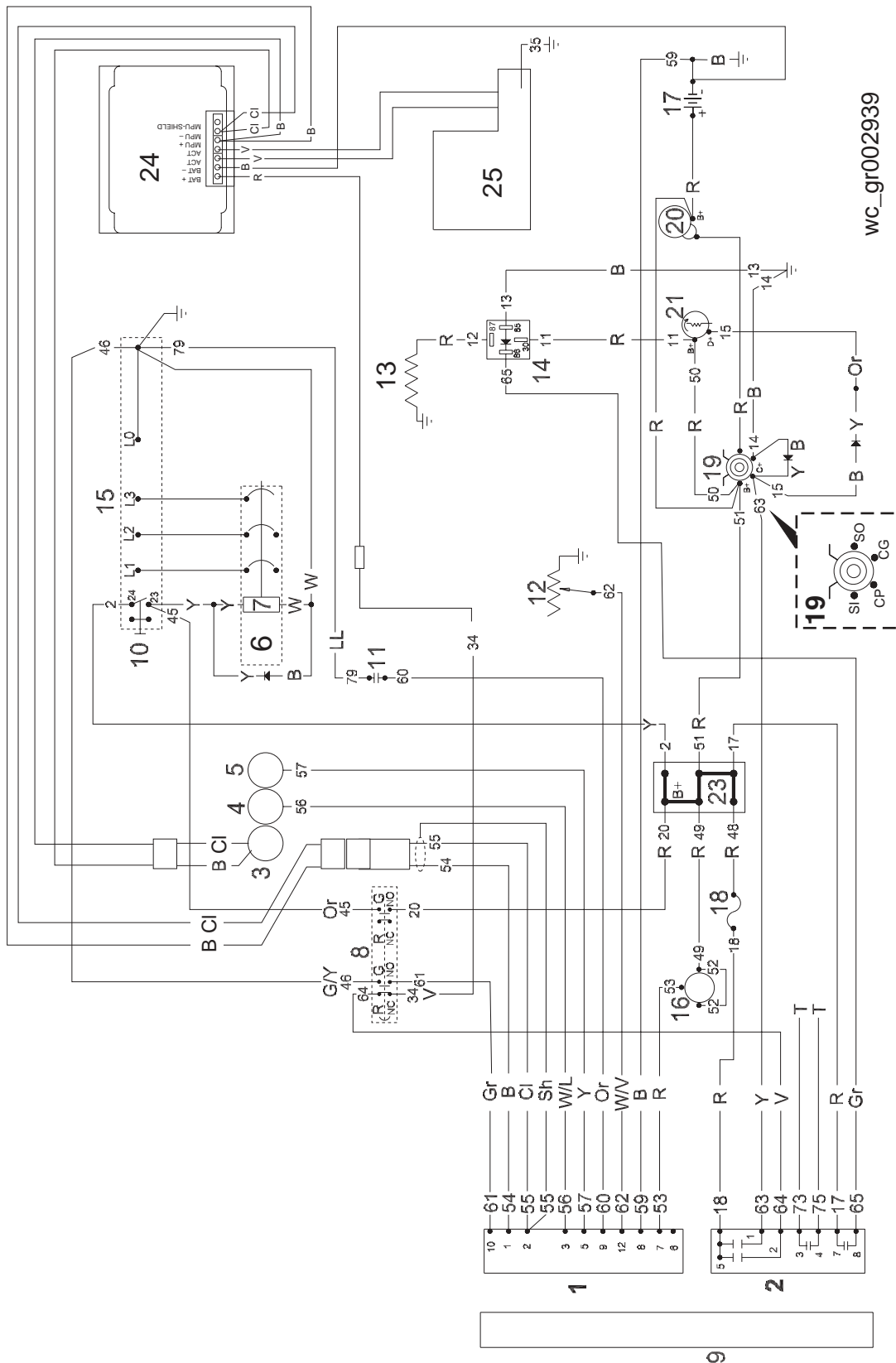

wc\_gr002939

**11.7 Components—John Deere Engine with Electronic Governor**

Ref.	Description	Ref.	Description
1	Plug 1 - engine sender inputs	14	Slave preheat relay
2	Plug 2 - engine start outputs	15	Mechanical lugs
3	Magnetic pickup	16	Remote Start - Off - Start/Run switch
4	Oil pressure sender	17	Battery
5	Coolant temperature sender	18	10A fuse
6	Main circuit breaker	19	Starter relay
7	Shunt trip, main breaker	20	Starter
8	Emergency Stop switch	21	Alternator
9	Engine control module (ECM)	22	---
10	Lug door switch	23	Terminal Block
11	Remote start terminals	24	Electronic governor
12	Fuel level sender	25-	Actuator
13	Intake heater	26	---

11.8 LCD Strip Heater

See Graphic: *wc\_gr001723, wc\_gr001724*

The LCD strip heater option includes a thermostat module **(a)** and a clear heater strip that is bonded to the LCD **(b)** of the ECM. The purpose of the strip heater is to prevent the LCD from being damaged by extremely cold temperatures. The resistance of the coiled element of the heater is sensed by the thermostat. The resistance of the element changes with temperature. At approximately -30°C, the resistance value triggers the thermostat to send power to the element. The LED **(c)** of the thermostat module flashes during operation.

It is important to note that the LCD strip heater is always on and thus draws power (a very small amount) from the battery even when the unit is not running. If the battery should fail, the heater will also fail. Be sure to keep the battery charged when the generator is not in use.



wc\_gr001723

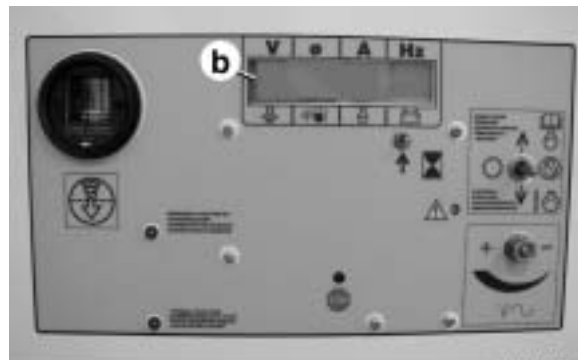

wc\_gr001724

## 11.9 Low Coolant Shutdown

See Graphic: *wc\_gr001708*

The low-coolant shutdown system consists of an electronic sensor that monitors coolant level. The sensor **(a)** is mounted to the radiator and wired into the ECM. The sensor probe **(b)** is submerged in radiator coolant. If the probe senses no coolant, it sends a signal to the ECM. The ECM program includes a 10-second timer to protect from nuisance shutdowns. If after the ten seconds coolant levels are still sensed as being low, the ECM shuts down the engine. The ECM will then display the “FAULT LOW WATER LEVEL”. Allow the engine to cool before adding additional coolant.



**NEVER** remove the radiator cap while the engine is hot! Pressurized coolant can cause serious burns.

If it is necessary to open the radiator, only do so with the engine off, and only when coolant is cool enough to touch with bare hands. Slowly loosen the radiator cap to relieve pressure first, before removing it completely.

**Note:** *The sensor may be disabled by unplugging the wire harness. This action will not shut down the machine.*

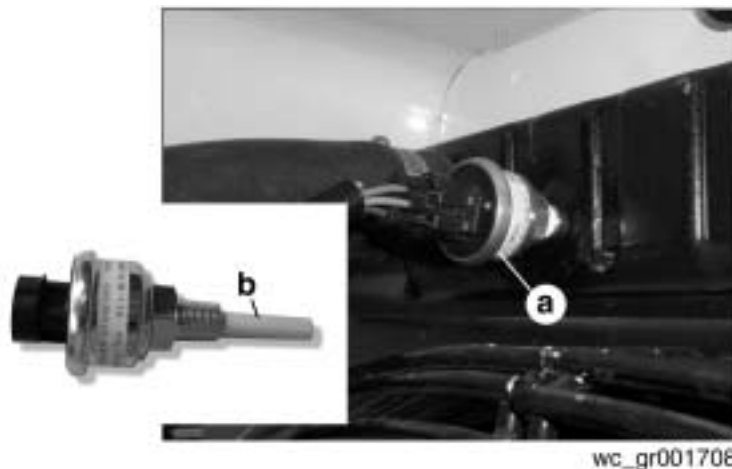

11.10 Lube Level Maintainer

See Graphic: *wc\_gr001711, wc\_gr001712, wc\_gr001713*

The lube level maintainer system protects the engine from low oil levels by providing an additional 6-quart oil reservoir. Oil from the reservoir is gravity-fed from the oil reservoir (a) through the control valve (b) and into the engine oil pan as needed. The valve includes a sightglass (c) through which the oil level can be seen. This oil level is the same as that measured by the engine dipstick. A float inside the valve detects low oil levels and opens the valve to supply the needed oil. The system is wired to the ECM and includes a low oil shutdown in case the oil in the reservoir is depleted. If the engine shuts down due to low oil, the ECM will display “FAULT LOW OIL LEVEL”. Fill the engine and the additional oil reservoir with oil before placing the generator back into service.

**Note:** *On machines with the Isuzu engine, the reservoir is mounted to the enclosure door.*

**CAUTION:** To prevent overfilling the engine with oil, place the shutoff valve (d) in the closed position when moving or towing the generator. Once the generator is in position, open the valve.



### 11.11 Temperature-Activated Shutters

See Graphic: *wc\_gr001706, wc\_gr001707*

The shutters **(a)** are mounted to the top of the generator enclosure. The shutters are designed to keep the engine compartment warm, thus increasing engine temperature during cold weather operation. The shutters are activated through a wax-pellet actuator **(b)** that is connected to the generator's cooling system. As radiator coolant warms, the wax-pellet actuator engages a linkage **(c)** that opens the shutters. As the coolant cools, the shutters close.



wc\_gr001707

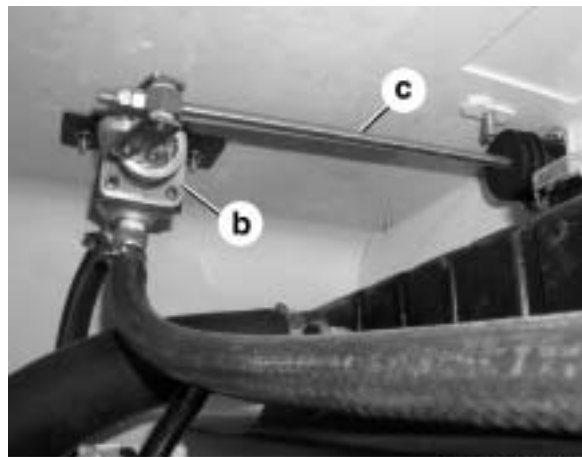

wc\_gr001706

11.12 Schematic—Temperature-Activated Shutters

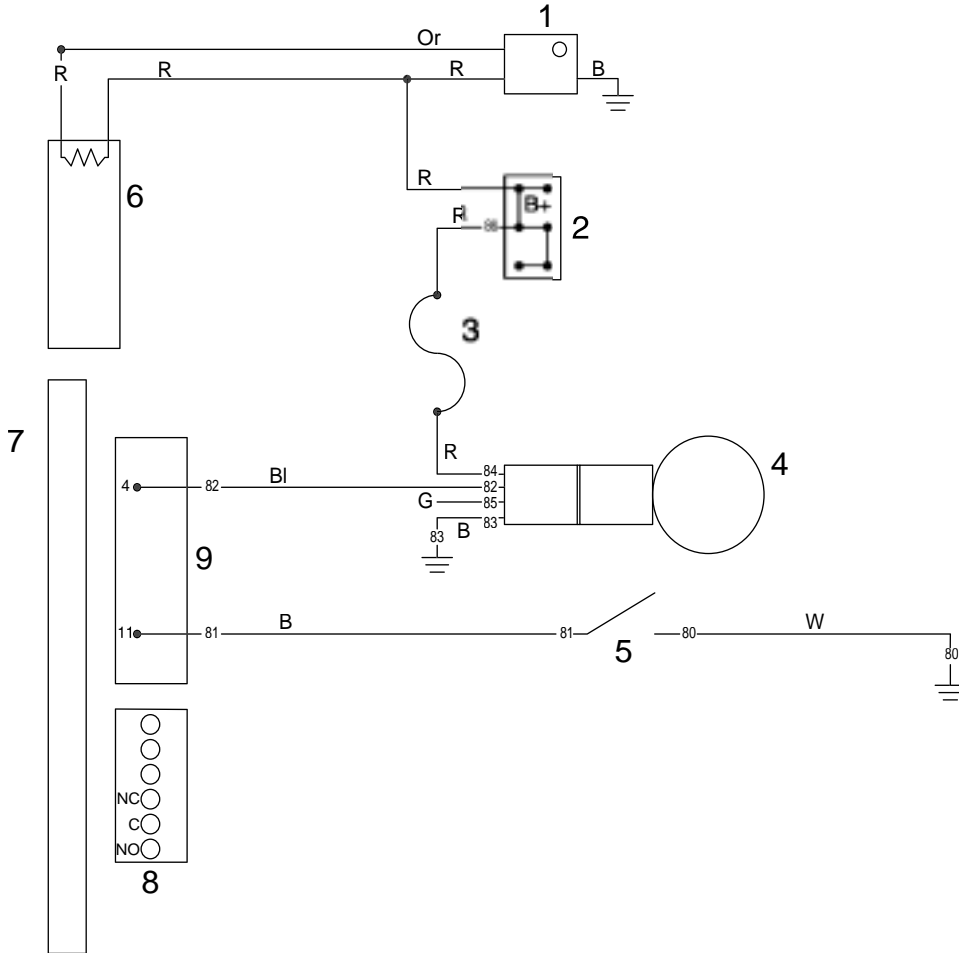

wc\_gr003174

Wire Colors							
B	Black	R	Red	Y	Yellow	Or	Orange
G	Green	T	Tan	Br	Brown	Pr	Purple
L	Blue	V	Violet	Cl	Clear	Sh	Shield
P	Pink	W	White	Gr	Gray	LL	Light blue

**11.13 Components—Temperature-Activated Shutters**

*See Graphic: wc\_gr003174*

Ref	Description	Ref	Description
1	Thermostat module	6	Auxiliary relay terminals
2	Terminal block	7	Plug 1, engine sensor inputs
3	1 Amp fuse	8	Electronic control board
4	Water level sensor	9	LCD heater
5	Lube level maintainer low level switch		



## Threadlockers and Sealants

### Threadlockers and Sealants

Threadlocking adhesives and sealants are specified throughout this manual by a notation of “S” plus a number (S#) and should be used where indicated. Threadlocking compounds normally break down at temperatures above 175°C (350°F). If a screw or bolt is hard to remove, heat it using a small propane torch to break down the sealant. When applying sealants, follow instructions on container. The sealants listed are recommended for use on Wacker equipment.

<b>TYPE ( ) = Europe</b>	<b>COLOR</b>	<b>USAGE</b>	<b>PART NO. – SIZE</b>
Loctite 222 Hernon 420 Omnifit 1150 (50M)	Purple	Low strength, for locking threads smaller than 6 mm (1/4”). Hand tool removable. Temp. range: -54 to 149°C (-65 to 300°F)	73287 - 10 ml
Loctite 243 Hernon 423 Omnifit 1350 (100M)	Blue	Medium strength, for locking threads larger than 6 mm (1/4”). Hand tool removable. Temp. range: -54 to 149°C (-65 to 300°F)	29311 - .5 ml 17380 - 50 ml
Loctite 271/277 Hernon 427 Omnifit 1550 (220M)	Red	High strength, for all threads up to 25 mm (1”). Heat parts before disassembly. Temp. range: -54 to 149°C (-65 to 300°F)	29312 - .5 ml 26685 - 10 ml 73285 - 50 ml
Loctite 290 Hernon 431 Omnifit 1710 (230LL)	Green	Medium to high strength, for locking preassembled threads and for sealing weld porosity (wicking). Gaps up to 0.13 mm (0.005”) Temp. range: -54 to 149°C (-65 to 300°F)	28824 - .5 ml 25316 - 10 ml
Loctite 609 Hernon 822 Omnifit 1730 (230L)	Green	Medium strength retaining compound for slip or press fit of shafts, bearings, gears, pulleys, etc. Gaps up to 0.13 mm (0.005”) Temp. range: -54 to 149°C (-65 to 300°F)	29314 - .5 ml
Loctite 545 Hernon 947 Omnifit 1150 (50M)	Brown	Hydraulic sealant Temp. range: -54 to 149°C (-65 to 300°F)	79356 - 50 ml
Loctite 592 Hernon 920 Omnifit 790	White	Pipe sealant with Teflon for moderate pressures. Temp. range: -54 to 149°C (-65 to 300°F)	26695 - 6 ml 73289 - 50 ml
Loctite 515 Hernon 910 Omnifit 10	Purple	Form-in-place gasket for flexible joints. Fills gaps up to 1.3 mm (0.05”) Temp. range: -54 to 149°C (-65 to 300°F)	70735 - 50 ml

## Threadlockers and Sealants



### Threadlockers and Sealants (continued)

Threadlocking adhesives and sealants are specified throughout this manual by a notation of “S” plus a number (S#) and should be used where indicated. Threadlocking compounds normally break down at temperatures above 175°C (350°F). If a screw or bolt is hard to remove, heat it using a small propane torch to break down the sealant. When applying sealants, follow instructions on container. The sealants listed are recommended for use on Wacker equipment.

<b>TYPE ( ) = Europe</b>	<b>COLOR</b>	<b>USAGE</b>	<b>PART NO. – SIZE</b>
Loctite 496 Hernon 110 Omnifit Sicomet 7000	Clear	Instant adhesive for bonding rubber, metal and plastics; general purpose. For gaps up to 0.15 mm (0.006”) Read caution instructions before using. Temp. range: -54 to 82°C (-65 to 180°F)	52676 - 1oz.
Loctite Primer T Hernon Primer 10 Omnifit VC Activator	Aerosol Spray	Fast curing primer for threadlocking, retaining and sealing compounds. Must be used with stainless steel hardware. Recommended for use with gasket sealants.	2006124-6 oz.

**Torque Values**

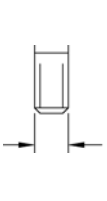
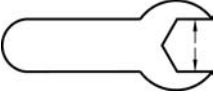
**Metric Fasteners (DIN)**

	TORQUE VALUES (Based on Bolt Size and Hardness)						WRENCH SIZE			
	8.8		10.9		12.9					
Size	Nm	ft.lb.	Nm	ft.lb.	Nm	ft.lb.	Metric	Inch	Metric	Inch
<b>M3</b>	1.2	*11	1.6	*14	2.1	*19	5.5	7/32	2.5	–
<b>M4</b>	2.9	*26	4.1	*36	4.9	*43	7	9/32	3	–
<b>M5</b>	6.0	*53	8.5	6	10	7	8	5/16	4	–
<b>M6</b>	10	7	14	10	17	13	10	–	5	–
<b>M8</b>	25	18	35	26	41	30	13	1/2	6	–
<b>M10</b>	49	36	69	51	83	61	17	11/16	8	–
<b>M12</b>	86	63	120	88	145	107	19	3/4	10	–
<b>M14</b>	135	99	190	140	230	169	22	7/8	12	–
<b>M16</b>	210	155	295	217	355	262	24	15/16	14	–
<b>M18</b>	290	214	405	298	485	357	27	1-1/16	14	–
<b>M20</b>	410	302	580	427	690	508	30	1-1/4	17	–

1 ft.lb. = 1.357 Nm





\* = in.lb.

1 inch = 25.4 mm

# Torque Values

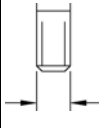
## Torque Values (continued)

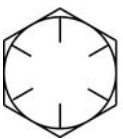
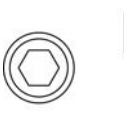
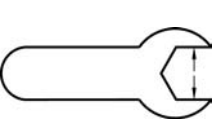
### Inch Fasteners (SAE)

	 <b>SAE 5</b>		 <b>SAE 8</b>							
	<b>Size</b>	<b>Nm</b>	<b>ft.lb.</b>	<b>Nm</b>	<b>ft.lb.</b>	<b>Nm</b>	<b>ft.lb.</b>	<b>Metric</b>	<b>Inch</b>	<b>Metric</b>
<b>No.4</b>	0.7	*6	1.0	*14	1.4	*12	5.5	1/4	–	3/32
<b>No.6</b>	1.4	*12	1.9	*17	2.4	*21	8	5/16	–	7/64
<b>No.8</b>	2.5	*22	3.5	*31	4.7	*42	9	11/32	–	9/64
<b>No.10</b>	3.6	*32	5.1	*45	6.8	*60	–	3/8	–	5/32
<b>1/4</b>	8.1	6	12	9	16	12	–	7/16	–	3/32
<b>5/16</b>	18	13	26	19	33	24	13	1/2	–	1/4
<b>3/8</b>	31	23	45	33	58	43	–	9/16	–	5/16
<b>7/16</b>	50	37	71	52	94	69	16	5/8	–	3/8
<b>1/2</b>	77	57	109	80	142	105	19	3/4	–	3/8
<b>9/16</b>	111	82	156	115	214	158	–	13/16	–	–
<b>5/8</b>	152	112	216	159	265	195	24	15/16	–	1/2
<b>3/4</b>	271	200	383	282	479	353	–	1-1/8	–	5/8

1 ft.lb. = 1.357 Nm

\* = in.lb.

1 inch = 25.4 mm



