

www.wackergroup.com

0171726en	002
1207	en

Mobile Generators

G 85



REPAIR MANUAL



This manual covers machines with Item Number:

0009369, 0009459, 0620003

Operating / Parts Information

You must be familiar with the operation of this machine before you attempt to troubleshoot or repair it. Basic operating and maintenance procedures are described in the Operator's Manual supplied with the machine. Keep a copy of the Operator's Manual with the machine at all times. Use the separate Parts Book supplied with the machine to order replacement parts. If you are missing either of the documents, please contact Wacker Corporation to order a replacement.

Damage caused by misuse or neglect of the unit should be brought to the attention of the operator to prevent similar occurrences from happening in the future.

This manual provides information and procedures to safely repair and maintain the above Wacker model(s). For your own safety and protection from injury, carefully read, understand, and observe all instructions described in this manual. THE INFORMATION CONTAINED IN THIS MANUAL IS BASED ON MACHINES MANUFACTURED UP TO THE TIME OF PUBLICATION. WACKER CORPORATION RESERVES THE RIGHT TO CHANGE ANY PORTION OF THIS INFORMATION WITHOUT NOTICE.

CALIFORNIA**Proposition 65 Warning:**

Diesel engine exhaust, some of its constituents, and certain vehicle components contain or emit chemicals known to the State of California to cause cancer and birth defects or other reproductive harm.

Laws Pertaining to Spark Arresters

Notice: State Health Safety Codes and Public Resources Codes specify that in certain locations spark arresters be used on internal combustion engines that use hydrocarbon fuels. A spark arrester is a device designed to prevent accidental discharge of sparks or flames from the engine exhaust. Spark arresters are qualified and rated by the United States Forest Service for this purpose.

In order to comply with local laws regarding spark arresters, consult the engine distributor or the local Health and Safety Administrator.

All rights, especially copying and distribution rights, are reserved.

Copyright 2007 by Wacker Corporation

No part of this publication may be reproduced in any form or by any means, electronic or mechanical, including photocopying, without express written permission from Wacker Corporation.

Any type of reproduction or distribution not authorized by Wacker Corporation represents an infringement of valid copyrights, and violators will be prosecuted. We expressly reserve the right to make technical modifications, even without due notice, which aim at improving our machines or their safety standards.

1. Safety Information	9
1.1 Operating Safety	11
1.2 Service Safety	13
1.3 Operator Safety while using Internal Combustion Engines	14
1.4 Towing Safety	15
1.5 Reporting Trailer Safety Defects	16
1.6 Label Location	17
1.7 Safety and Operating Labels	19
2. Theory of Operation	27
2.1 Basic Schematic	27
2.2 Introduction	28
2.3 Terminology	30
2.4 Generator Systems	34
2.5 Power Generation & Output	34
2.6 Voltage Regulation	38
2.7 Engine Start	40
2.8 ECM Monitoring System	42
3. Electrical Testing Techniques	46
3.1 Checking Continuity	46
3.2 Checking Resistance	46
3.3 Checking Voltage	46
3.4 Probing ECM Plugs and Pins	47
4. ECM Background Information	48
4.1 ECM Handling Precaution	48
4.2 Normal Boot-up Sequence	49
4.3 Display Variables and Values	52
4.4 ECM Display Screens—Start Switch in Remote Position	53
4.5 Additional Variables Monitored by the ECM	54
4.6 Voltage Display Errors	60
4.7 ECM Automatic Engine Shutdown Conditions	62
4.8 ECM Circuit Boards	63

4.9	Control Wiring Numbering & Colors	64
4.10	Removing and Installing the ECM	67
5.	ECM/Sensor Troubleshooting	68
5.1	Checking Power to the ECM	68
5.2	Checking Outgoing Power From the ECM	71
5.3	Checking Temperature Sender	72
5.4	Fuel Sender Failure and Low Fuel Fault	74
5.5	Calibrating ECM Voltage Display	75
5.6	Calibrating ECM AC Amperage Display	76
5.7	Calibrating ECM AC Frequency Display	77
5.8	Calibrating ECM DC Display	78
5.9	ECM Plugs and Pins	79
6.	John Deere Engine's With ECU	81
6.1	John Deere Engine's With ECU Background	81
6.2	Locations of Engine Electrical Components	82
6.3	Engine Electrical Components	83
7.	Engine Starting Troubleshooting—John Deere with ECU	84
7.1	Checking the Fuses	84
7.2	Checking the Engine Control Module (ECM)	85
7.3	Checking the Emergency Stop Switch	86
7.4	Checking the Starter Relay	87
7.5	Checking the Starter Solenoid	88
7.6	Checking the Intake Heater Relay	89
8.	Output Voltage Troubleshooting	90
8.1	Checking the Emergency Stop Switch	90
8.2	Checking the Lug Door Switch Prerequisites	91
8.3	Checking the Main Circuit Breaker	92
8.4	Checking the Voltage Adjusting Rheostat	93

8.5	Checking the Auxiliary Winding	94
8.6	Checking the Exciter Stator	95
8.7	Checking the AVR Sensing Wires	96
8.8	Flashing the Generator (checking the excitation system)	97
8.9	Checking Stator Windings at the Lugs	98
8.10	Checking the Rectifier Diodes	99
8.11	Checking the Main Rotor Winding	100
8.12	Checking the Exciter Rotor Winding	101
8.13	Checking Stator Windings at the Voltage Selector Switch	102

9. Disassembly/Assembly Procedures 103

9.1	Tools	103
9.2	Ordering Parts	103
9.3	Reference Numbers ()	103
9.4	Weight Block	103
9.5	Removing the Roof	104
9.6	Preparing Unit for Generator Removal	106
9.7	Replacing the Generator	108
9.8	Removing the AVR	110
9.9	Installing the AVR	111
9.10	Removing the Engine	114
9.11	Installing the Engine	116
9.12	Replacing the Fuel Tank	118
9.13	Replacing the Emergency Stop Switch (older)	120
9.14	Replacing the Emergency Stop Switch (newer)	122
9.15	Replacing the Voltage Selector Switch (VSS)	124

10. Factory-Installed Options 128

10.1	Block Heater	128
10.2	Fuel/Water Separator	129
10.3	Electronic Governor	130
10.4	Adjusting the Electronic Governor Module	131
10.5	Woodward Electronic Governor LED Status Indicator	132
10.6	Troubleshooting the Electronic Governor	133
10.7	Schematic—Isuzu Engine with Electronic Governor	134
10.8	Components—Isuzu Engine with Electronic Governor	135
10.9	Schematic—John Deere Engine with Electronic Governor	136

10.10	Components—John Deere Engine with Electronic Governor	137
10.11	LCD Strip Heater	138
10.12	Low Coolant Shutdown	139
10.13	Lube Level Maintainer	140
10.14	Temperature-Activated Shutters	141
10.15	Schematic	142
10.16	Components	143

11. Technical Data**144**

11.1	Engine Data	144
11.2	Generator Data	145
11.3	Trailer and Skid Data	147
11.4	Dimensions	147
11.5	Engine Wiring Diagram—John Deere with ECU	148
11.6	ECU Wiring Diagram	152
11.7	ECU Harness Connector	153
11.8	Generator Wiring Diagram	154

1. Safety Information

This manual contains DANGER, WARNING, CAUTION, *NOTICE* and NOTE callouts which must be followed to reduce the possibility of personal injury, damage to the equipment, or improper service.



This is the safety alert symbol. It is used to alert you to potential personal injury hazards. Obey all safety messages that follow this symbol to avoid possible injury or death.



DANGER

DANGER indicates a hazardous situation which, if not avoided, will result in death or serious injury.



WARNING

WARNING indicates a hazardous situation which, if not avoided, could result in death or serious injury.



CAUTION

CAUTION indicates a hazardous situation which, if not avoided, could result in minor or moderate injury.

NOTICE: Used without the safety alert symbol, **NOTICE** indicates a hazardous situation which, if not avoided, could result in property damage.

Note: *Contains additional information important to a procedure.*



DANGER

Danger of Electrocution!

Danger of electrocution or severe electrical shock is present throughout the generator any time the engine is running! Read all safety notes contained in this section before operating or servicing this equipment.

No one except a trained electrician, familiar with this equipment, should attempt repairs to the generator! Test procedures which require that the generator be running must be performed using extreme caution.

This machine is built with user safety in mind; however, like any electrical device it can present serious hazards if improperly operated and serviced. Follow instructions carefully! Should questions arise during operation or service of this equipment, contact Wacker Corporation.

1.1 Operating Safety



Familiarity and proper training are required for the safe operation of the machine. Machines operated improperly or by untrained personnel can be dangerous. Read the operating instructions contained in both this manual and the Engine Manual and familiarize yourself with the location and proper use of all controls. Inexperienced operators should receive instruction from someone familiar with the machine before being allowed to operate it.

- 1.1.1 NEVER operate the generator when open containers of fuel, paint, or other flammable liquids are near.
- 1.1.2 NEVER place flammable material or liquids near the generator.
- 1.1.3 NEVER operate the generator, or tools attached to the generator, with wet hands.
- 1.1.4 NEVER use worn electrical cords. Severe electrical shock and equipment damage may result.
- 1.1.5 NEVER operate the machine indoors unless exhaust fumes can be adequately ventilated.
- 1.1.6 NEVER overload the generator. The total amperage of the tools and equipment attached to the generator must not exceed the load rating of the generator.
- 1.1.7 NEVER allow untrained personnel to operate or service the generator. The generator set should be set up by a certified electrician.
- 1.1.8 NEVER operate generator in standing water.
- 1.1.9 NEVER touch the hot engine, exhaust, or generator components. Burns will result.
- 1.1.10 NEVER start a machine in need of repair.
- 1.1.11 Use the emergency stop button only in an actual emergency. DO NOT restart the engine until the cause of the trouble has been determined and fixed.
- 1.1.12 ALWAYS wear hearing protection when operating equipment.
- 1.1.13 ALWAYS follow starting and stopping instructions described in this manual. Know how to operate and stop generator before starting it.
- 1.1.14 ALWAYS make a walk-around inspection of the generator set before starting it. Open side doors and visually inspect engine compartment for obvious damage or the presence of foreign objects which might affect operation.
- 1.1.15 ALWAYS keep the machine at least one meter (three feet) away from structures, buildings, and other equipment during use.
- 1.1.16 ALWAYS store the machine properly when it is not being used. The machine should be stored in a clean, dry location out of the reach of children.

- 1.1.17 ALWAYS keep the area immediately surrounding and underneath the machine clean, neat, and free of debris and combustible materials. Make sure that the area overhead is clear of debris that could fall onto or into the machine or exhaust compartment.
- 1.1.18 ALWAYS be sure the machine is on a firm, level surface and will not tip, roll, slide, or fall while operating.
- 1.1.19 ALWAYS remove all tools, cords, and other loose items from the generator before starting it.
- 1.1.20 ALWAYS make certain the machine is well-grounded and securely fastened to a good earthen ground per national and local regulations.



BACKFEED FROM THE GENERATOR INTO THE PUBLIC POWER DISTRIBUTION SYSTEM CAN CAUSE SERIOUS INJURY OR DEATH TO UTILITY WORKERS!

Improper connection of generator to a building's electrical system can allow electrical current from the generator to backfeed into utility lines. This may result in electrocution of utility workers, fire, or explosion. Connections to a building's electrical system must be made by a qualified electrician and comply with all applicable laws and electrical codes.

If connected to a building's electrical system the generator must meet the power, voltage, and frequency requirements of the equipment in the building. Differences in power, voltage, and frequency requirements may exist and improper connection may lead to equipment damage, fire, and personal injury or death.

1.2 Service Safety



A poorly maintained machine can become a safety hazard! In order for the machine to operate safely and properly over a long period of time, periodic maintenance and occasional repairs are necessary.

- 1.2.1 NEVER perform even routine service (oil/filter changes, cleaning, etc.) unless all electrical components are shut down.** Before servicing this machine, make sure the engine start switch is turned to off “O”, the circuit breakers are open (off), the emergency stop switch is closed (pushed in), and the negative terminal on battery is disconnected. Attach a “DO NOT START” sign to the control panel. This will notify everyone that the unit is being serviced and will reduce the chance of someone inadvertently trying to start the unit. If the unit is connected to a remote start or transfer switch, make sure the remote switch is also off and tagged.
- 1.2.2 Ground Connection**
The generator must be connected to a good earthen ground for proper operating safety!
A central “equipment ground” is provided at the customer connection lugs. This point is connected directly to the generator set base. All other system grounds are connected to this central point. Ground the generator in accordance with the standards defined in national, state and local regulations.
- 1.2.3 DO NOT attempt to open the radiator cap while the unit is running or before the engine has cooled down. Severe burns may result!**
- 1.2.4 DO NOT allow water to accumulate around the base of the machine. If water is present, move the machine and allow the machine to dry before servicing.**
- 1.2.5 DO NOT service the machine if your clothing or skin is wet.**
- 1.2.6 DO NOT allow untrained personnel to service this equipment. Only trained electrical technicians should be allowed to service the electrical components of this equipment.**
- 1.2.7 DO NOT modify the machine without the express written approval of the manufacturer.**
- 1.2.8 DO NOT pressure wash the control panel, generator end, or any other electrical components when cleaning the unit. Never allow water to accumulate around the base of the generator set. If water is present, DO NOT service!**
- 1.2.9 ALWAYS replace the safety devices and guards after repairs and maintenance.**
- 1.2.10 ALWAYS let the engine cool before transporting or servicing it.**

- 1.2.11 ALWAYS remain aware of moving parts and keep hands, feet, and loose clothing away from the moving parts of the machine.
- 1.2.12 ALWAYS replace all guards, fasten doors and make sure all safety devices operate properly after making repairs or servicing the equipment.
- 1.2.13 ALWAYS keep hands, feet, and loose clothing away from the moving parts on the generator and engine.
- 1.2.14 ALWAYS keep the machine clean and labels legible. Replace all missing and hard-to-read labels. Labels provide important operating instructions and warn of dangers and hazards.
- 1.2.15 ALWAYS check all external fasteners at regular intervals.
- 1.2.16 ALWAYS make sure slings, chains, hooks, ramps, jacks and other types of lifting devices are attached securely and have enough weight-bearing capacity to lift or hold the machine safely. Always remain aware of the location of other people in the area when lifting the machine.

1.3 Operator Safety while using Internal Combustion Engines



DANGER

Internal combustion engines present special hazards during operation and fueling. Read and follow the warning instructions in the engine Owner's Manual and the safety guidelines below. Failure to follow the warnings and safety standards could result in severe injury or death.

- 1.3.1 DO NOT run engine indoors or in an area with poor ventilation unless exhaust hoses are used.
- 1.3.2 DO NOT fill or drain the fuel tank near an open flame, while smoking, or while the engine is running.
- 1.3.3 DO NOT refuel a hot or running engine.
- 1.3.4 ALWAYS refill the fuel tank in a well-ventilated area.
- 1.3.5 DO NOT touch or lean against hot exhaust pipes.
- 1.3.6 ALWAYS replace the fuel tank cap after refueling.
- 1.3.7 DO NOT start the engine if fuel has spilled or a fuel odor is present. Move the generator away from the spill and wipe the generator dry before starting.
- 1.3.8 DO NOT remove the radiator cap when the engine is running or hot. The radiator fluid is hot and under pressure and may cause severe burns!

1.4 Towing Safety



WARNING

Towing a large trailer requires special care. Both the trailer and vehicle must be in good condition and securely fastened to each other to reduce the possibility of an accident.

- 1.4.1 ALWAYS check that the hitch and coupling on the vehicle are rated equal to, or greater than, the trailer's "gross vehicle weight rating" (GVWR).
- 1.4.2 ALWAYS inspect the hitch and coupling for wear or damage. DO NOT tow the trailer using defective parts.
- 1.4.3 ALWAYS make sure the coupling is securely fastened to the vehicle.
- 1.4.4 ALWAYS check the tires on the trailer for tread wear, inflation, and condition. Replace worn tires.
- 1.4.5 ALWAYS connect the safety chains.
- 1.4.6 ALWAYS connect the breakaway cable safety hook to the bumper or rear of the vehicle. DO NOT attach it to the hitch.
- 1.4.7 ALWAYS test the surge brakes on the trailer and the brakes on the vehicle that will be used for towing.
- 1.4.8 ALWAYS make sure directional and trailer lights are connected and working properly.
- 1.4.9 ALWAYS check that the lug nuts holding the wheels are tight and that none are missing.

1.5 Reporting Trailer Safety Defects

If you believe your trailer has a defect which could cause a crash or could cause injury or death, you should immediately inform the National Highway Traffic Safety Administration (NHTSA) in addition to notifying Wacker Corporation.

If NHTSA receives similar complaints, it may open an investigation; and if it finds that a safety defect exists in a group of vehicles, it may order a recall and remedy campaign. However, NHTSA cannot become involved in individual problems between you, your dealer, or Wacker Corporation.

To contact NHTSA, you may either contact the Auto Safety Hotline toll-free at 1-800-424-9393 (or 366-0129 in Washington DC area), www.nhtsa.com, or write to NHTSA, U.S. Department of Transportation, 400 7th Street SW, (NSA-11), Washington, DC 20590. You can also obtain other information about motor vehicle safety from the Auto Safety Hotline.

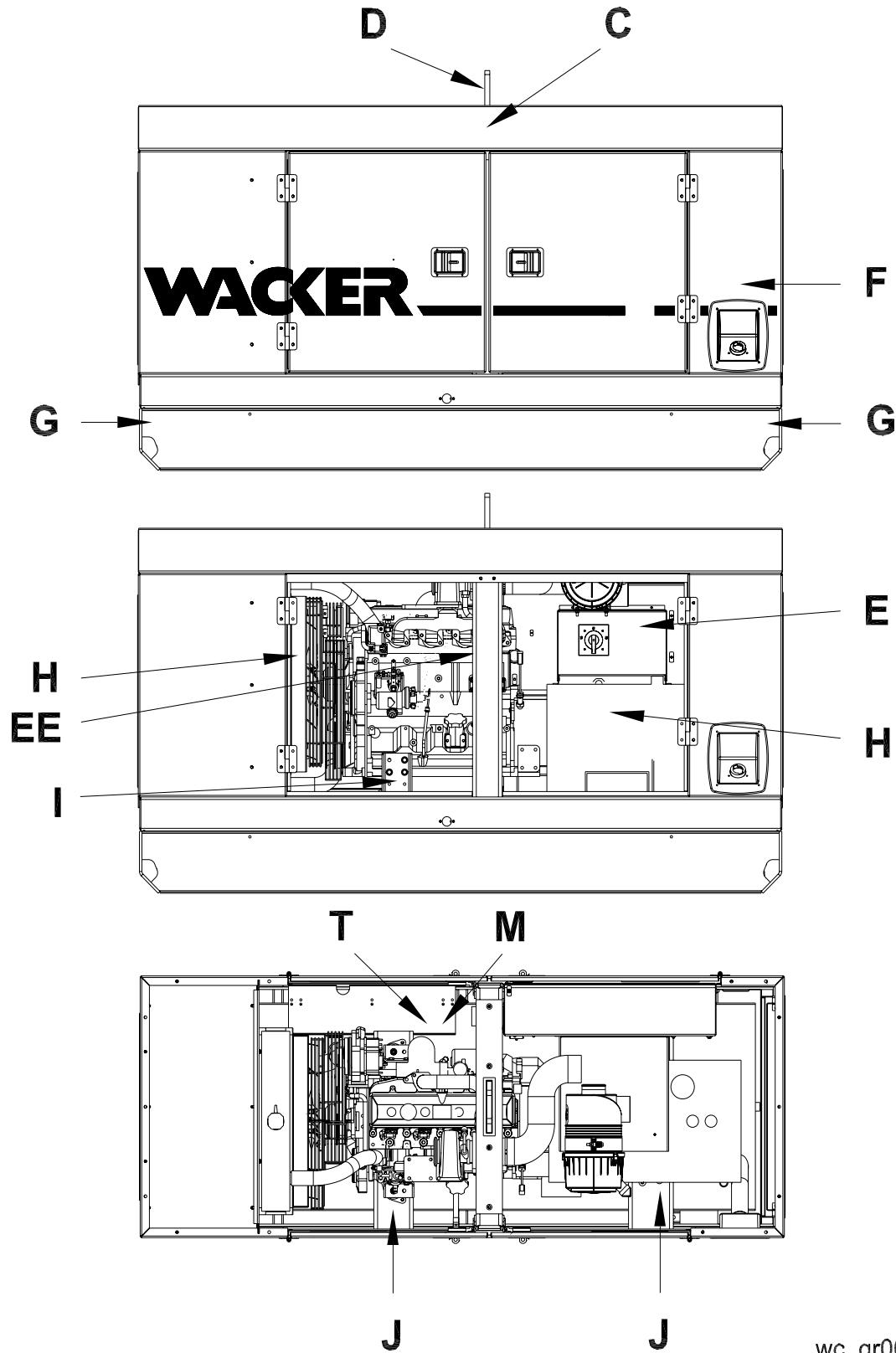

1.6 Label Location



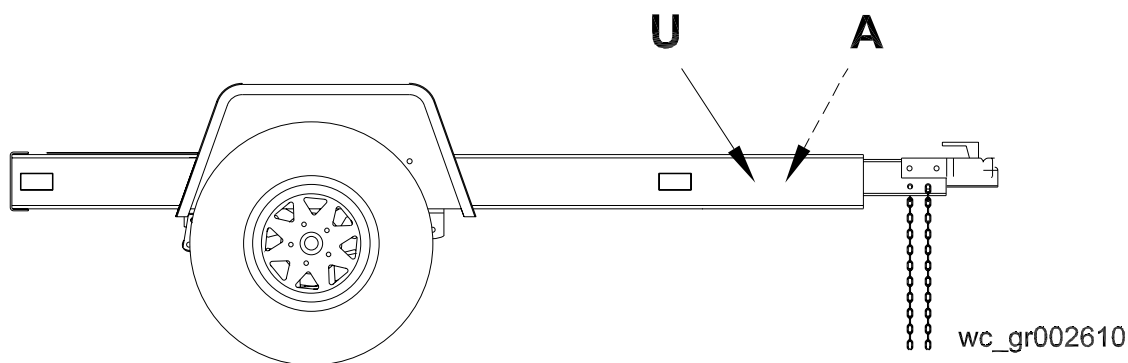
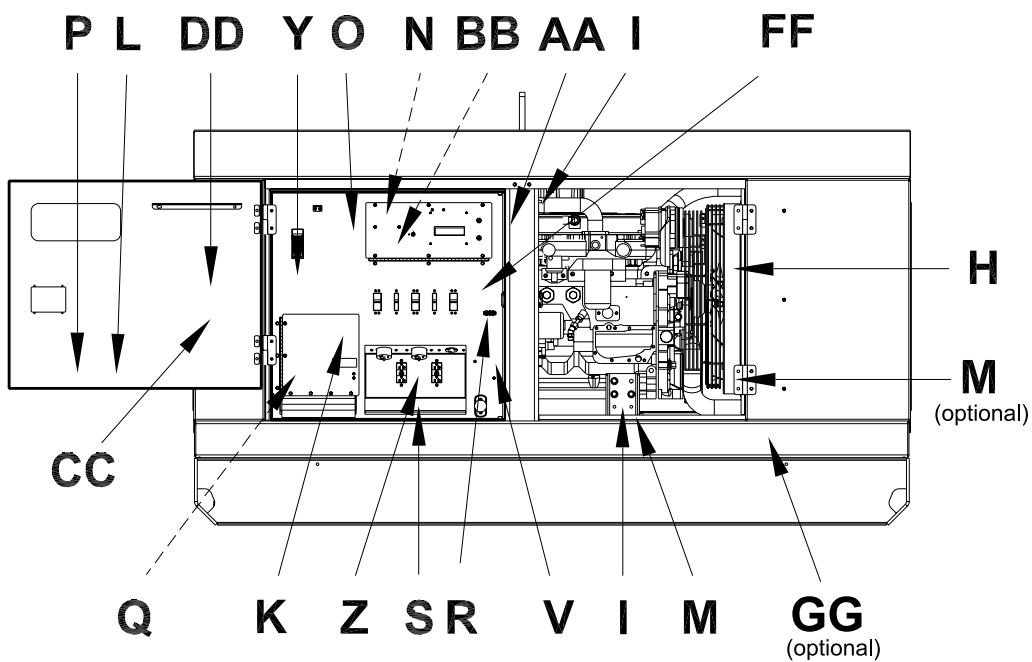
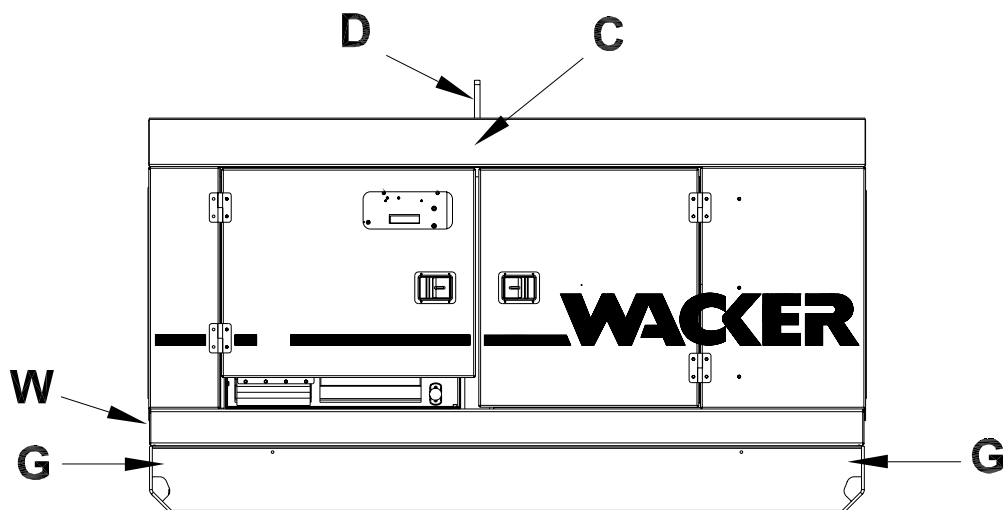



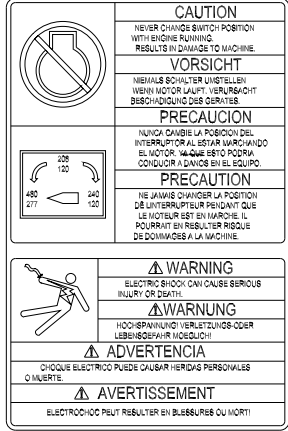

wc_gr002609

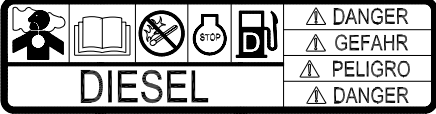

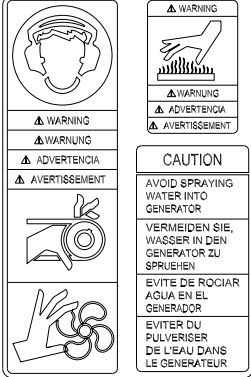

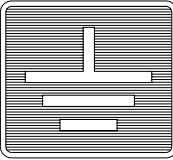
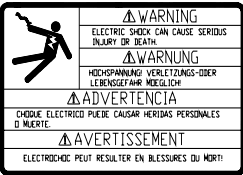

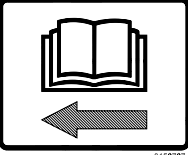

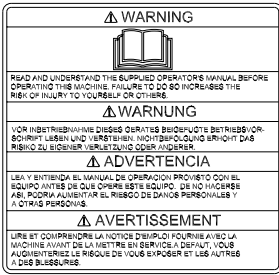
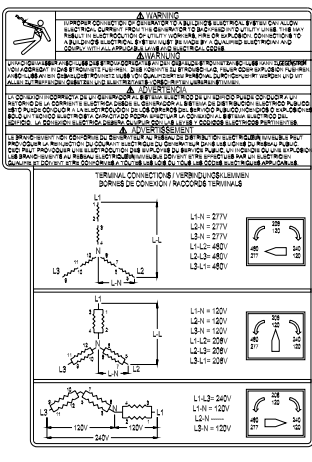

1.7 Safety and Operating Labels

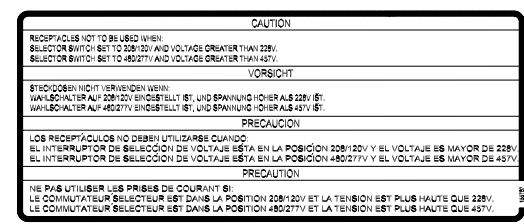
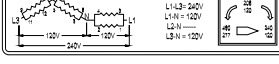

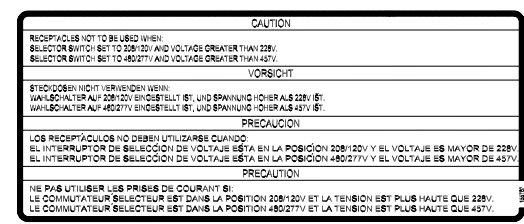
Ref.	Label	Meaning								
A	<table border="1"> <thead> <tr> <th data-bbox="310 411 570 432">TOWING INSTRUCTIONS</th> <th data-bbox="570 411 841 432">ABSCHLEPPINSTRUKTIONEN</th> <th data-bbox="841 411 1101 432">INSTRUCCIONES DE REMOLQUE</th> <th data-bbox="1101 411 1393 432">INSTRUCTIONS DE REMORQUAGE</th> </tr> </thead> <tbody> <tr> <td data-bbox="310 432 570 558"> 1. READ OPERATOR'S MANUAL. 2. USE HITCH RATED FOR TRAILER'S "GROSS VEHICLE WEIGHT RATING". 3. SECURELY ATTACH TRAILER TO TOW VEHICLE. 4. ATTACH SAFETY CHAINS USING CROSS PATTERN. 5. ATTACH BREAKDOWN CHAIN TO VEHICLE. 6. CHECK TRAILER LIGHTS. </td> <td data-bbox="570 432 841 558"> 1. BETRIEBSVORSCHRIFT LESEN. 2. ANHANGEVORRICHTUNG VERWENDEN, DIE DER GESAMTBETRIEBSGEWICHTSKLASSE ENTSPRICHT. 3. ANHÄNGER SICHER AM ZUGFAHRZEUG BEFESTIGEN. 4. SICHERHEITSKETTEN KREUZWEISE ANBRINGEN. 5. ABREISSKETTE AM FAHRZEUG ANBRINGEN. 6. ANHÄNGERLEUCHTEN PRÜFEN. </td> <td data-bbox="841 432 1101 558"> 1. LEA EL MANUAL DEL OPERARIO. 2. UTILICE UN ACOPLE CORRECTAMENTE CLASIFICADO PARA LA "CLASE DE PESO BUTO" DEL VEHICULO DEL REMOLQUE. 3. ASEGURESE DE AMARRAR CORRECTAMENTE EL REMOLQUE AL VEHICULO DE REMOLQUE. 4. FIJE EN CRUZ LAS CADENAS DE SEGURIDAD. 5. FIJE EN EL VEHICULO DE REMOLQUE LA CADENA DE DESPRENDIMIENTO. 6. CONTROLE LAS LUCES DEL REMOLQUE. </td> <td data-bbox="1101 432 1393 558"> 1. LIRE LA NOTICE D'EMPLOI. 2. UTILISER UN GROCHET D'ATTACHE CONFORME AU DEBIT NOMINAL DU POIDS BRUT DE VEHICULE DU TRACTEUR. 3. ATTACHER LA REMORQUE FERMEMENT AU VEHICULE TRACTEUR. 4. ATTACHER LES CHAINES DE SURETTE EN UTILISANT UNE METHODE CROISEE. 5. ATTACHER LA CHAINE DE REMORQUAGE AU VEHICULE. 6. VERIFIER LES LAMPES DE LA REMORQUE. </td> </tr> </tbody> </table>	TOWING INSTRUCTIONS	ABSCHLEPPINSTRUKTIONEN	INSTRUCCIONES DE REMOLQUE	INSTRUCTIONS DE REMORQUAGE	1. READ OPERATOR'S MANUAL. 2. USE HITCH RATED FOR TRAILER'S "GROSS VEHICLE WEIGHT RATING". 3. SECURELY ATTACH TRAILER TO TOW VEHICLE. 4. ATTACH SAFETY CHAINS USING CROSS PATTERN. 5. ATTACH BREAKDOWN CHAIN TO VEHICLE. 6. CHECK TRAILER LIGHTS.	1. BETRIEBSVORSCHRIFT LESEN. 2. ANHANGEVORRICHTUNG VERWENDEN, DIE DER GESAMTBETRIEBSGEWICHTSKLASSE ENTSPRICHT. 3. ANHÄNGER SICHER AM ZUGFAHRZEUG BEFESTIGEN. 4. SICHERHEITSKETTEN KREUZWEISE ANBRINGEN. 5. ABREISSKETTE AM FAHRZEUG ANBRINGEN. 6. ANHÄNGERLEUCHTEN PRÜFEN.	1. LEA EL MANUAL DEL OPERARIO. 2. UTILICE UN ACOPLE CORRECTAMENTE CLASIFICADO PARA LA "CLASE DE PESO BUTO" DEL VEHICULO DEL REMOLQUE. 3. ASEGURESE DE AMARRAR CORRECTAMENTE EL REMOLQUE AL VEHICULO DE REMOLQUE. 4. FIJE EN CRUZ LAS CADENAS DE SEGURIDAD. 5. FIJE EN EL VEHICULO DE REMOLQUE LA CADENA DE DESPRENDIMIENTO. 6. CONTROLE LAS LUCES DEL REMOLQUE.	1. LIRE LA NOTICE D'EMPLOI. 2. UTILISER UN GROCHET D'ATTACHE CONFORME AU DEBIT NOMINAL DU POIDS BRUT DE VEHICULE DU TRACTEUR. 3. ATTACHER LA REMORQUE FERMEMENT AU VEHICULE TRACTEUR. 4. ATTACHER LES CHAINES DE SURETTE EN UTILISANT UNE METHODE CROISEE. 5. ATTACHER LA CHAINE DE REMORQUAGE AU VEHICULE. 6. VERIFIER LES LAMPES DE LA REMORQUE.	
TOWING INSTRUCTIONS	ABSCHLEPPINSTRUKTIONEN	INSTRUCCIONES DE REMOLQUE	INSTRUCTIONS DE REMORQUAGE							
1. READ OPERATOR'S MANUAL. 2. USE HITCH RATED FOR TRAILER'S "GROSS VEHICLE WEIGHT RATING". 3. SECURELY ATTACH TRAILER TO TOW VEHICLE. 4. ATTACH SAFETY CHAINS USING CROSS PATTERN. 5. ATTACH BREAKDOWN CHAIN TO VEHICLE. 6. CHECK TRAILER LIGHTS.	1. BETRIEBSVORSCHRIFT LESEN. 2. ANHANGEVORRICHTUNG VERWENDEN, DIE DER GESAMTBETRIEBSGEWICHTSKLASSE ENTSPRICHT. 3. ANHÄNGER SICHER AM ZUGFAHRZEUG BEFESTIGEN. 4. SICHERHEITSKETTEN KREUZWEISE ANBRINGEN. 5. ABREISSKETTE AM FAHRZEUG ANBRINGEN. 6. ANHÄNGERLEUCHTEN PRÜFEN.	1. LEA EL MANUAL DEL OPERARIO. 2. UTILICE UN ACOPLE CORRECTAMENTE CLASIFICADO PARA LA "CLASE DE PESO BUTO" DEL VEHICULO DEL REMOLQUE. 3. ASEGURESE DE AMARRAR CORRECTAMENTE EL REMOLQUE AL VEHICULO DE REMOLQUE. 4. FIJE EN CRUZ LAS CADENAS DE SEGURIDAD. 5. FIJE EN EL VEHICULO DE REMOLQUE LA CADENA DE DESPRENDIMIENTO. 6. CONTROLE LAS LUCES DEL REMOLQUE.	1. LIRE LA NOTICE D'EMPLOI. 2. UTILISER UN GROCHET D'ATTACHE CONFORME AU DEBIT NOMINAL DU POIDS BRUT DE VEHICULE DU TRACTEUR. 3. ATTACHER LA REMORQUE FERMEMENT AU VEHICULE TRACTEUR. 4. ATTACHER LES CHAINES DE SURETTE EN UTILISANT UNE METHODE CROISEE. 5. ATTACHER LA CHAINE DE REMORQUAGE AU VEHICULE. 6. VERIFIER LES LAMPES DE LA REMORQUE.							
B		<p>WARNING! Pressurized contents. Do not open when hot!</p>								
C		<p>WARNING! Lock doors. Access can cause electric shock or injury.</p>								
D		<p>CAUTION! Lifting point.</p>								
E		<p>CAUTION! Never change switch position with engine running. Results in damage to machine.</p> <p>WARNING! Electric shock will cause serious injury or death.</p>								

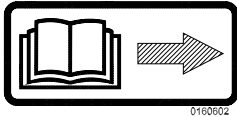
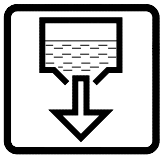

Ref.	Label	Meaning
F		<p>DANGER! Asphyxiation hazard. Read the Operator's Manual for instructions. No sparks, flames, or burning objects near machine. Stop the engine before adding fuel. Use only diesel fuel.</p>
G		<p>Tie-down point.</p>
H		<p>WARNING! To prevent hearing loss, wear hearing protection. Hand injury if entangled in moving belt. Rotating machinery! Do not reach inside with engine running. WARNING! Hot surface! CAUTION! Avoid spraying water into generator.</p>
I		<p>WARNING! Hot surface!</p>
J		<p>Electrical ground</p>
K		<p>WARNING! Electric shock will cause serious injury or death.</p>

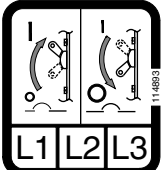

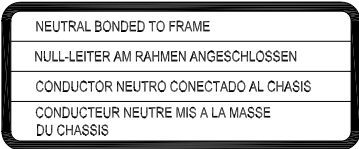
Ref.	Label	Meaning							
L	<table border="1" style="width: 100%; border-collapse: collapse;"> <tr> <td style="width: 50%; padding: 5px;"> <p style="text-align: center;">OPERATING INSTRUCTIONS FOR MOBILE GENERATORS</p> <p>BEFORE STARTING</p> <ol style="list-style-type: none"> 1. READ OPERATOR'S MANUAL. 2. LEVEL UNIT. 3. BLOCK WHEELS. 4. GROUND UNIT. 5. CHECK ALL FLUID LEVELS. <p>MANUAL STARTING</p> <ol style="list-style-type: none"> 1. DISCONNECT ALL EXTERNAL LOADS. 2. SET VOLTAGE SELECTOR SWITCH. 3. LOCK VOLTAGE SELECTOR SWITCH. (#2 & #3 NOT INCLUDED ON G12) 4. TURN EMERGENCY STOP BUTTON TO "ON" POSITION. 5. PUSH ENGINE START SWITCH TO "START/RUN" POSITION. 6. ENGINE WILL MAKE 3 ATTEMPTS TO START. <p>REMOTE START</p> <ol style="list-style-type: none"> 1. SEE OPERATOR'S MANUAL. <p>STOPPING</p> <ol style="list-style-type: none"> 1. DISCONNECT ALL EXTERNAL LOADS. 2. PUSH ENGINE START SWITCH TO "OFF" POSITION. 3. FILL FUEL TANK. </td> <td style="width: 50%; padding: 5px;"> <p style="text-align: center;">BETRIEBSANLEITUNG FÜR MOBILEAGGREGATE</p> <p>VOR DEM STARTEN</p> <ol style="list-style-type: none"> 1. BETRIEBSVORSCHRIFT LESEN. 2. GERÄT WAAGRECHT STELLEN. 3. RÄDER BLOCKIEREN. 4. GERÄT ERDEN. 5. STAND ALLER FLÜSSIGKEITEN PRÜFEN. <p>HANDSTARTEN</p> <ol style="list-style-type: none"> 1. ALLE AUSSEREN BELASTUNGEN ABSCHALTEN. 2. SPANNUNGSWAHLSCHALTER SETZEN. 3. SPANNUNGSWAHLSCHALTER VERRIEGELN. (#2 & #3 NICHT EINGESCHLOSSEN MIT G12) 4. NOTSTOPKNOPF IN "ON" POSITION SETZEN. 5. MOTORSTARTSCHALTER AUF POSITION "START/LAUF" DRÜCKEN. 6. MOTOR VOLLZIEHT 3 STARTVERSUCHE. <p>FERNSTART</p> <ol style="list-style-type: none"> 1. SIEHE BETRIEBSVORSCHRIFT. <p>ABSCHALTEN</p> <ol style="list-style-type: none"> 1. ALLE AUSSEREN BELASTUNGEN ABSCHALTEN. 2. MOTORSTARTSCHALTER AUF POSITION "OFF" DRÜCKEN. 3. KRAFTSTOFFTANK FÜLLEN. </td> </tr> <tr> <td style="width: 50%; padding: 5px;"> <p style="text-align: center;">INSTRUCCIONES PARA LA PUESTA EN MARCHA DE GENERADORES MOVILES</p> <p>ANTES DEL ARRANQUE</p> <ol style="list-style-type: none"> 1. LEA EL MANUAL DEL OPERARIO. 2. NIVELA LA UNIDAD. 3. COLOQUE CÚNAS DEBAJO DE LAS RUEDAS. 4. CONECTE LA UNIDAD A TIERRA. 5. CONTROLE TODOS LOS LIQUIDOS. <p>ARRANQUE MANUAL</p> <ol style="list-style-type: none"> 1. DESCONECTE TODAS LAS CARGAS EXTERNAS. 2. AJUSTE LA LLAVE SELECTORA DE VOLTAJE. 3. BLOQUEE LA LLAVE SELECTORA DE VOLTAJE. (#2 & #3 NO ESTA INCLUIDO CON G12) 4. GIRE A LA POSICION "ON" EL BOTON DE PARADA DE EMERGENCIA. 5. OPRIMA A LA POSICION "ARRANQUE/MARCHA" EL INTERRUPTOR DE ARRANQUE DEL MOTOR. 6. EL MOTOR INTENTARA ARRANCAR 3 VECES. <p>ARRANQUE REMOTO</p> <ol style="list-style-type: none"> 1. VEA EL MANUAL DEL OPERARIO. <p>DETENCION DEL MOTOR</p> <ol style="list-style-type: none"> 1. DESCONECTE TODAS LAS CARGAS EXTERNAS. 2. OPRIMA A LA POSICION "OFF" EL INTERRUPTOR DE ARRANQUE DEL MOTOR. 3. LLENE EL TANQUE DE COMBUSTIBLE. </td> <td style="width: 50%; padding: 5px;"> <p style="text-align: center;">INSTRUCTIONS D'OPERATION DU GENERATEUR MOBILE</p> <p>AVANT LE DEMARRAGE</p> <ol style="list-style-type: none"> 1. LIRE LA NOTICE D'EMPLOI. 2. NIVELER LA MACHINE. 3. BLOQUER LES ROUES AVEC CALES DE ROUES. 4. METTRE A TERRE LA MACHINE. 5. VERIFIER LE NIVEAU DE TOUS LES FLUIDES. <p>DEMARRAGE A LA MAIN</p> <ol style="list-style-type: none"> 1. DECONNECTER TOUS LES REGIMES EXTERNES. 2. REGLER LE COMMUTATEUR DES TENSIONS D'ALIMENTATION. 3. SERRER LE COMMUTATEUR DES TENSIONS D'ALIMENTATION. (#2 & #3 PAS COMPRIS AVEC G12) 4. TOURNER LE BOUTON D'ARRET D'URGENCE A LA POSITION "ON". 5. PRESSER LE BOUTON "DEMARRAGE" DU MOTEUR A LA POSITION "DEMARRAGE/MARCHE". 6. LE MOTEUR ESSAYE DE DEMARRER 3 FOIS. <p>DEMARRAGE A DISTANCE</p> <ol style="list-style-type: none"> 1. LIRE LA NOTICE D'EMPLOI. <p>ARRRET</p> <ol style="list-style-type: none"> 1. DECONNECTER TOUS LES REGIMES EXTERNES. 2. PRESSER LE BOUTON "DEMARRAGE" DU MOTEUR A LA POSITION "OFF". 3. REMPLIR LE RESERVOIR A CARBURANT. </td> </tr> <tr> <td style="width: 25%; padding: 5px;"> <p>OPERATOR'S MANUAL MUST BE STORED ON MACHINE. REPLACEMENT OPERATOR'S MANUAL CAN BE ORDERED THROUGH YOUR LOCAL WACKER DISTRIBUTOR.</p> </td> <td style="width: 25%; padding: 5px;"> <p>DIE BETRIEBSVORSCHRIFT MUSS AN DER MASCHINE AUFBEWAHRT WERDEN. ZUR BESTELLUNG VON ERSATZBUCHERN WENDEN SIE SICH BITTE AN IHREN ORTLICHEN WACKER HANDLER.</p> </td> <td style="width: 50%; padding: 5px;"> <p>EL MANUAL DE OPERACION DEBE SER RETENIDO EN LA MAQUINA. CONTACTE A SU DISTRIBUIDOR WACKER MAS CERCAO PARA PEDIR UN EJEMPLAR ADICIONAL.</p> <p>LA NOTICE D'EMPLOI DOIT ETRE MUNIE SUR LA MACHINE. CONTACTER LE DISTRIBUTEUR WACKER LE PLUS PROCHE POUR COMMANDER UN EXEMPLAIRE SUPPLEMENTAIRE.</p> </td> </tr> </table>	<p style="text-align: center;">OPERATING INSTRUCTIONS FOR MOBILE GENERATORS</p> <p>BEFORE STARTING</p> <ol style="list-style-type: none"> 1. READ OPERATOR'S MANUAL. 2. LEVEL UNIT. 3. BLOCK WHEELS. 4. GROUND UNIT. 5. CHECK ALL FLUID LEVELS. <p>MANUAL STARTING</p> <ol style="list-style-type: none"> 1. DISCONNECT ALL EXTERNAL LOADS. 2. SET VOLTAGE SELECTOR SWITCH. 3. LOCK VOLTAGE SELECTOR SWITCH. (#2 & #3 NOT INCLUDED ON G12) 4. TURN EMERGENCY STOP BUTTON TO "ON" POSITION. 5. PUSH ENGINE START SWITCH TO "START/RUN" POSITION. 6. ENGINE WILL MAKE 3 ATTEMPTS TO START. <p>REMOTE START</p> <ol style="list-style-type: none"> 1. SEE OPERATOR'S MANUAL. <p>STOPPING</p> <ol style="list-style-type: none"> 1. DISCONNECT ALL EXTERNAL LOADS. 2. PUSH ENGINE START SWITCH TO "OFF" POSITION. 3. FILL FUEL TANK. 	<p style="text-align: center;">BETRIEBSANLEITUNG FÜR MOBILEAGGREGATE</p> <p>VOR DEM STARTEN</p> <ol style="list-style-type: none"> 1. BETRIEBSVORSCHRIFT LESEN. 2. GERÄT WAAGRECHT STELLEN. 3. RÄDER BLOCKIEREN. 4. GERÄT ERDEN. 5. STAND ALLER FLÜSSIGKEITEN PRÜFEN. <p>HANDSTARTEN</p> <ol style="list-style-type: none"> 1. ALLE AUSSEREN BELASTUNGEN ABSCHALTEN. 2. SPANNUNGSWAHLSCHALTER SETZEN. 3. SPANNUNGSWAHLSCHALTER VERRIEGELN. (#2 & #3 NICHT EINGESCHLOSSEN MIT G12) 4. NOTSTOPKNOPF IN "ON" POSITION SETZEN. 5. MOTORSTARTSCHALTER AUF POSITION "START/LAUF" DRÜCKEN. 6. MOTOR VOLLZIEHT 3 STARTVERSUCHE. <p>FERNSTART</p> <ol style="list-style-type: none"> 1. SIEHE BETRIEBSVORSCHRIFT. <p>ABSCHALTEN</p> <ol style="list-style-type: none"> 1. ALLE AUSSEREN BELASTUNGEN ABSCHALTEN. 2. MOTORSTARTSCHALTER AUF POSITION "OFF" DRÜCKEN. 3. KRAFTSTOFFTANK FÜLLEN. 	<p style="text-align: center;">INSTRUCCIONES PARA LA PUESTA EN MARCHA DE GENERADORES MOVILES</p> <p>ANTES DEL ARRANQUE</p> <ol style="list-style-type: none"> 1. LEA EL MANUAL DEL OPERARIO. 2. NIVELA LA UNIDAD. 3. COLOQUE CÚNAS DEBAJO DE LAS RUEDAS. 4. CONECTE LA UNIDAD A TIERRA. 5. CONTROLE TODOS LOS LIQUIDOS. <p>ARRANQUE MANUAL</p> <ol style="list-style-type: none"> 1. DESCONECTE TODAS LAS CARGAS EXTERNAS. 2. AJUSTE LA LLAVE SELECTORA DE VOLTAJE. 3. BLOQUEE LA LLAVE SELECTORA DE VOLTAJE. (#2 & #3 NO ESTA INCLUIDO CON G12) 4. GIRE A LA POSICION "ON" EL BOTON DE PARADA DE EMERGENCIA. 5. OPRIMA A LA POSICION "ARRANQUE/MARCHA" EL INTERRUPTOR DE ARRANQUE DEL MOTOR. 6. EL MOTOR INTENTARA ARRANCAR 3 VECES. <p>ARRANQUE REMOTO</p> <ol style="list-style-type: none"> 1. VEA EL MANUAL DEL OPERARIO. <p>DETENCION DEL MOTOR</p> <ol style="list-style-type: none"> 1. DESCONECTE TODAS LAS CARGAS EXTERNAS. 2. OPRIMA A LA POSICION "OFF" EL INTERRUPTOR DE ARRANQUE DEL MOTOR. 3. LLENE EL TANQUE DE COMBUSTIBLE. 	<p style="text-align: center;">INSTRUCTIONS D'OPERATION DU GENERATEUR MOBILE</p> <p>AVANT LE DEMARRAGE</p> <ol style="list-style-type: none"> 1. LIRE LA NOTICE D'EMPLOI. 2. NIVELER LA MACHINE. 3. BLOQUER LES ROUES AVEC CALES DE ROUES. 4. METTRE A TERRE LA MACHINE. 5. VERIFIER LE NIVEAU DE TOUS LES FLUIDES. <p>DEMARRAGE A LA MAIN</p> <ol style="list-style-type: none"> 1. DECONNECTER TOUS LES REGIMES EXTERNES. 2. REGLER LE COMMUTATEUR DES TENSIONS D'ALIMENTATION. 3. SERRER LE COMMUTATEUR DES TENSIONS D'ALIMENTATION. (#2 & #3 PAS COMPRIS AVEC G12) 4. TOURNER LE BOUTON D'ARRET D'URGENCE A LA POSITION "ON". 5. PRESSER LE BOUTON "DEMARRAGE" DU MOTEUR A LA POSITION "DEMARRAGE/MARCHE". 6. LE MOTEUR ESSAYE DE DEMARRER 3 FOIS. <p>DEMARRAGE A DISTANCE</p> <ol style="list-style-type: none"> 1. LIRE LA NOTICE D'EMPLOI. <p>ARRRET</p> <ol style="list-style-type: none"> 1. DECONNECTER TOUS LES REGIMES EXTERNES. 2. PRESSER LE BOUTON "DEMARRAGE" DU MOTEUR A LA POSITION "OFF". 3. REMPLIR LE RESERVOIR A CARBURANT. 	<p>OPERATOR'S MANUAL MUST BE STORED ON MACHINE. REPLACEMENT OPERATOR'S MANUAL CAN BE ORDERED THROUGH YOUR LOCAL WACKER DISTRIBUTOR.</p>	<p>DIE BETRIEBSVORSCHRIFT MUSS AN DER MASCHINE AUFBEWAHRT WERDEN. ZUR BESTELLUNG VON ERSATZBUCHERN WENDEN SIE SICH BITTE AN IHREN ORTLICHEN WACKER HANDLER.</p>	<p>EL MANUAL DE OPERACION DEBE SER RETENIDO EN LA MAQUINA. CONTACTE A SU DISTRIBUIDOR WACKER MAS CERCAO PARA PEDIR UN EJEMPLAR ADICIONAL.</p> <p>LA NOTICE D'EMPLOI DOIT ETRE MUNIE SUR LA MACHINE. CONTACTER LE DISTRIBUTEUR WACKER LE PLUS PROCHE POUR COMMANDER UN EXEMPLAIRE SUPPLEMENTAIRE.</p>	<p style="text-align: center;">OPERATOR'S MANUAL MUST BE STORED ON MACHINE. REPLACEMENT OPERATOR'S MANUAL CAN BE ORDERED THROUGH YOUR LOCAL WACKER DISTRIBUTOR.</p>
<p style="text-align: center;">OPERATING INSTRUCTIONS FOR MOBILE GENERATORS</p> <p>BEFORE STARTING</p> <ol style="list-style-type: none"> 1. READ OPERATOR'S MANUAL. 2. LEVEL UNIT. 3. BLOCK WHEELS. 4. GROUND UNIT. 5. CHECK ALL FLUID LEVELS. <p>MANUAL STARTING</p> <ol style="list-style-type: none"> 1. DISCONNECT ALL EXTERNAL LOADS. 2. SET VOLTAGE SELECTOR SWITCH. 3. LOCK VOLTAGE SELECTOR SWITCH. (#2 & #3 NOT INCLUDED ON G12) 4. TURN EMERGENCY STOP BUTTON TO "ON" POSITION. 5. PUSH ENGINE START SWITCH TO "START/RUN" POSITION. 6. ENGINE WILL MAKE 3 ATTEMPTS TO START. <p>REMOTE START</p> <ol style="list-style-type: none"> 1. SEE OPERATOR'S MANUAL. <p>STOPPING</p> <ol style="list-style-type: none"> 1. DISCONNECT ALL EXTERNAL LOADS. 2. PUSH ENGINE START SWITCH TO "OFF" POSITION. 3. FILL FUEL TANK. 	<p style="text-align: center;">BETRIEBSANLEITUNG FÜR MOBILEAGGREGATE</p> <p>VOR DEM STARTEN</p> <ol style="list-style-type: none"> 1. BETRIEBSVORSCHRIFT LESEN. 2. GERÄT WAAGRECHT STELLEN. 3. RÄDER BLOCKIEREN. 4. GERÄT ERDEN. 5. STAND ALLER FLÜSSIGKEITEN PRÜFEN. <p>HANDSTARTEN</p> <ol style="list-style-type: none"> 1. ALLE AUSSEREN BELASTUNGEN ABSCHALTEN. 2. SPANNUNGSWAHLSCHALTER SETZEN. 3. SPANNUNGSWAHLSCHALTER VERRIEGELN. (#2 & #3 NICHT EINGESCHLOSSEN MIT G12) 4. NOTSTOPKNOPF IN "ON" POSITION SETZEN. 5. MOTORSTARTSCHALTER AUF POSITION "START/LAUF" DRÜCKEN. 6. MOTOR VOLLZIEHT 3 STARTVERSUCHE. <p>FERNSTART</p> <ol style="list-style-type: none"> 1. SIEHE BETRIEBSVORSCHRIFT. <p>ABSCHALTEN</p> <ol style="list-style-type: none"> 1. ALLE AUSSEREN BELASTUNGEN ABSCHALTEN. 2. MOTORSTARTSCHALTER AUF POSITION "OFF" DRÜCKEN. 3. KRAFTSTOFFTANK FÜLLEN. 								
<p style="text-align: center;">INSTRUCCIONES PARA LA PUESTA EN MARCHA DE GENERADORES MOVILES</p> <p>ANTES DEL ARRANQUE</p> <ol style="list-style-type: none"> 1. LEA EL MANUAL DEL OPERARIO. 2. NIVELA LA UNIDAD. 3. COLOQUE CÚNAS DEBAJO DE LAS RUEDAS. 4. CONECTE LA UNIDAD A TIERRA. 5. CONTROLE TODOS LOS LIQUIDOS. <p>ARRANQUE MANUAL</p> <ol style="list-style-type: none"> 1. DESCONECTE TODAS LAS CARGAS EXTERNAS. 2. AJUSTE LA LLAVE SELECTORA DE VOLTAJE. 3. BLOQUEE LA LLAVE SELECTORA DE VOLTAJE. (#2 & #3 NO ESTA INCLUIDO CON G12) 4. GIRE A LA POSICION "ON" EL BOTON DE PARADA DE EMERGENCIA. 5. OPRIMA A LA POSICION "ARRANQUE/MARCHA" EL INTERRUPTOR DE ARRANQUE DEL MOTOR. 6. EL MOTOR INTENTARA ARRANCAR 3 VECES. <p>ARRANQUE REMOTO</p> <ol style="list-style-type: none"> 1. VEA EL MANUAL DEL OPERARIO. <p>DETENCION DEL MOTOR</p> <ol style="list-style-type: none"> 1. DESCONECTE TODAS LAS CARGAS EXTERNAS. 2. OPRIMA A LA POSICION "OFF" EL INTERRUPTOR DE ARRANQUE DEL MOTOR. 3. LLENE EL TANQUE DE COMBUSTIBLE. 	<p style="text-align: center;">INSTRUCTIONS D'OPERATION DU GENERATEUR MOBILE</p> <p>AVANT LE DEMARRAGE</p> <ol style="list-style-type: none"> 1. LIRE LA NOTICE D'EMPLOI. 2. NIVELER LA MACHINE. 3. BLOQUER LES ROUES AVEC CALES DE ROUES. 4. METTRE A TERRE LA MACHINE. 5. VERIFIER LE NIVEAU DE TOUS LES FLUIDES. <p>DEMARRAGE A LA MAIN</p> <ol style="list-style-type: none"> 1. DECONNECTER TOUS LES REGIMES EXTERNES. 2. REGLER LE COMMUTATEUR DES TENSIONS D'ALIMENTATION. 3. SERRER LE COMMUTATEUR DES TENSIONS D'ALIMENTATION. (#2 & #3 PAS COMPRIS AVEC G12) 4. TOURNER LE BOUTON D'ARRET D'URGENCE A LA POSITION "ON". 5. PRESSER LE BOUTON "DEMARRAGE" DU MOTEUR A LA POSITION "DEMARRAGE/MARCHE". 6. LE MOTEUR ESSAYE DE DEMARRER 3 FOIS. <p>DEMARRAGE A DISTANCE</p> <ol style="list-style-type: none"> 1. LIRE LA NOTICE D'EMPLOI. <p>ARRRET</p> <ol style="list-style-type: none"> 1. DECONNECTER TOUS LES REGIMES EXTERNES. 2. PRESSER LE BOUTON "DEMARRAGE" DU MOTEUR A LA POSITION "OFF". 3. REMPLIR LE RESERVOIR A CARBURANT. 								
<p>OPERATOR'S MANUAL MUST BE STORED ON MACHINE. REPLACEMENT OPERATOR'S MANUAL CAN BE ORDERED THROUGH YOUR LOCAL WACKER DISTRIBUTOR.</p>	<p>DIE BETRIEBSVORSCHRIFT MUSS AN DER MASCHINE AUFBEWAHRT WERDEN. ZUR BESTELLUNG VON ERSATZBUCHERN WENDEN SIE SICH BITTE AN IHREN ORTLICHEN WACKER HANDLER.</p>	<p>EL MANUAL DE OPERACION DEBE SER RETENIDO EN LA MAQUINA. CONTACTE A SU DISTRIBUIDOR WACKER MAS CERCAO PARA PEDIR UN EJEMPLAR ADICIONAL.</p> <p>LA NOTICE D'EMPLOI DOIT ETRE MUNIE SUR LA MACHINE. CONTACTER LE DISTRIBUTEUR WACKER LE PLUS PROCHE POUR COMMANDER UN EXEMPLAIRE SUPPLEMENTAIRE.</p>							
M	 	<p>Operator's Manual must be stored on machine. Replacement Operator's Manual can be ordered through your local Wacker distributor.</p>							
N		<p>DANGER! Electric shock will cause serious injury or death. Danger of asphyxiation!</p>							

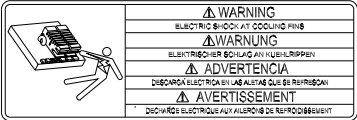
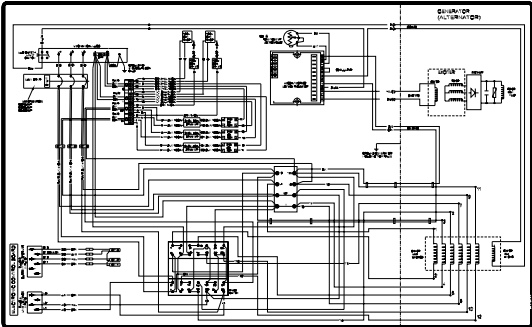
Ref.	Label	Meaning
O	 <p>WARNING GENERATOR CAN AUTOMATICALLY START WHICH CAN CAUSE SERIOUS INJURY. DISCONNECT BATTERY BEFORE SERVICING.</p> <p>ADVERTENCIA GENERADOR PUEDE ARRANCAR AUTOMÁTICAMENTE Y CAUSAR LESIONES PERSONALES. DESCONECTE EL BATERÍA ANTES DE PRESTAR SERVICIO.</p> <p>AVERTISSEMENT GÉNÉRATEUR PEUT DÉMARRER AUTOMATIQUEMENT. DÉCONNECTEZ LA BATTERIE AVANT TOUT ENTRETIEN.</p>	<p>WARNING! Generator can automatically start which can cause serious injury. Disconnect battery before servicing.</p>
P	 <p>WARNING READ AND UNDERSTAND THE SUPPLIED OPERATOR'S MANUAL BEFORE OPERATING THE MACHINE. FAILURE TO DO SO INCREASES THE RISK OF INJURY TO YOURSELF OR OTHERS.</p> <p>ADVERTENCIA LEA Y ENTIENDA EL MANUAL DE OPERACION PROPORCIONADO CON EL EQUIPO ANTES DE QUE OPERE ESTE EQUIPO. DE NO HACERSE ASÍ, PODRÁ AUMENTAR EL RIESGO DE DAÑOS PERSONALES Y A OTRAS PERSONAS.</p> <p>AVERTISSEMENT LIRE ET COMPRENDEZ LA NOTICE D'UTILISATION FOURNIE AVEC LA MACHINE AVANT DE LA METTRE EN SERVICE. A DÉFAUT, VOS AUGMENTERIEZ LE RISQUE DE VOUS EXPOSER ET LES AUTRES À DES BLESSURES.</p>	<p>WARNING! Read and understand the supplied Operator's Manual before operating the machine. Failure to do so increases the risk of injury to yourself or others.</p>
Q	 <p>WARNING TO REDUCE THE RISK OF ELECTRICAL SHOCK, READ THE OPERATOR'S MANUAL. IMPROPER CONNECTION OF THE GENERATOR TO A BUILDING'S ELECTRICAL SYSTEM CAN ALLOW ELECTRICAL CURRENT FROM THE GENERATOR TO BACKFEED INTO UTILITY LINES. THIS MAY RESULT IN ELECTROCUTION OF UTILITY WORKERS, FIRE OR EXPLOSION. CONNECTIONS TO A BUILDING'S ELECTRICAL SYSTEM MUST BE MADE BY A QUALIFIED ELECTRICIAN AND COMPLY WITH ALL APPLICABLE LAWS AND ELECTRICAL CODES.</p> <p>ADVERTENCIA PARA REDUCIR EL RIESGO DE GOLPES ELÉCTRICOS, LEA EL MANUAL DEL OPERARIO. LA CONEXIÓN INCORRECTA DEL GENERADOR AL SISTEMA ELÉCTrico DE UN EDIFICIO PUEDE PERMITIR QUE LA CORRIENTE ELÉCTrica DEL GENERADOR SE REINTEGRE EN LAS LÍNEAS DE UTILIDAD. ESTO PUEDE RESULTAR EN LA ELECTROCUCIÓN DE LOS TRABAJADORES DE UTILIDAD, INCENDIOS O EXPLOSIONES. LAS CONEXIONES AL SISTEMA ELÉCTrico DE UN EDIFICIO DEBEN SER HECHAS POR UN ELECTRICISTA CALIFICADO Y DEBE CUMPLIRSE CON TODAS LAS LEYES Y CÓDIGOS ELÉCTricos APLICABLES.</p> <p>AVERTISSEMENT POUR RÉDUIRE LE RISQUE DE CHOC ÉLECTRIQUE, LIRE LE MANUEL DE L'OPÉRATEUR. UNE MAUVAISE RACCORDEMENT DU GÉNÉRATEUR À UN SYSTÈME ÉLECTRIQUE D'UN BÂTIMENT PEUT PERMETTRE À L'ÉLECTRICITÉ DU GÉNÉRATEUR D'ALIMENTER LES LIGNES D'UTILITÉ. CELA PEUT CAUSER LA MORT ÉLECTRIQUE DES TRAVAILLEURS D'UTILITÉ, DES INCENDIES OU DES EXPLOSIONS. LES RACCORDEMENTS À UN SYSTÈME ÉLECTRIQUE D'UN BÂTIMENT DOIVENT ÊTRE RÉALISÉS PAR UN ÉLECTRICIEN QUALIFIÉ ET ÊTRE EN CONFORMITÉ AVEC TOUTES LES LOIS ET LES NORMES ÉLECTRIQUES APPLICABLES.</p> <p>TERMINAL CONNECTIONS VERBODEN AANSLUITEN DORRANS DE CONNEXION PROHIBES CONEXIONES</p> <p>    </p>	<p>WARNING! To reduce the risk of electrical shock, read the operator's manual. Improper connection of the generator to a building's electrical system can allow electrical current from the generator to backfeed into utility lines. This may result in electrocution of utility workers, fire or explosion. Connections to a building's electrical system must be made by a qualified electrician and comply with all applicable laws and electrical codes.</p>
R	 <p>REMOTE START FERNSTART ARRANQUE REMOTO DEMARRAGE A DISTANCE</p>	<p>Remote start operation. Read operator's manual for instructions.</p>
S	 <p>CAUTION RECEPTACLES NOT TO BE USED WHEN: SELECTOR SWITCH SET TO 208/120V AND VOLTAGE GREATER THAN 228V; SELECTOR SWITCH SET TO 480/277V AND VOLTAGE GREATER THAN 457V.</p> <p>VORSICHT STÖCKDOSEN NICHT VERWENDEN WEENN: WAHLSCWALTER AUF 208/120V EINGESTELLT IST, UND SPANNUNG HÖHER ALS 228V IST; WAHLSCWALTER AUF 480/277V EINGESTELLT IST, UND SPANNUNG HÖHER ALS 457V IST.</p> <p>PRECAUCION LOS RECEPTÁCULOS NO DEBEN UTILIZARSE CUANDO: EL INTERRUPTOR DE SELECCIÓN DE VOLTAJE ESTÁ EN LA POSICIÓN 208/120V Y EL VOLTAJE ES MAYOR DE 228V; EL INTERRUPTOR DE SELECCIÓN DE VOLTAJE ESTÁ EN LA POSICIÓN 480/277V Y EL VOLTAJE ES MAYOR DE 457V.</p> <p>PRECAUTION NE PAS UTILISER LES PRISES DE COURANT SI: LE COMMANDEUR SELECTEUR EST DANS LA POSITION 208/120V ET LA TENSION EST PLUS HAUTE QUE 228V; LE COMMANDEUR SELECTEUR EST DANS LA POSITION 480/277V ET LA TENSION EST PLUS HAUTE QUE 457V.</p>	<p>CAUTION! Receptacles not to be used when: Selector switch set to 208/120V and voltage greater than 228V. Selector switch set to 480/277V and voltage greater than 457V.</p>

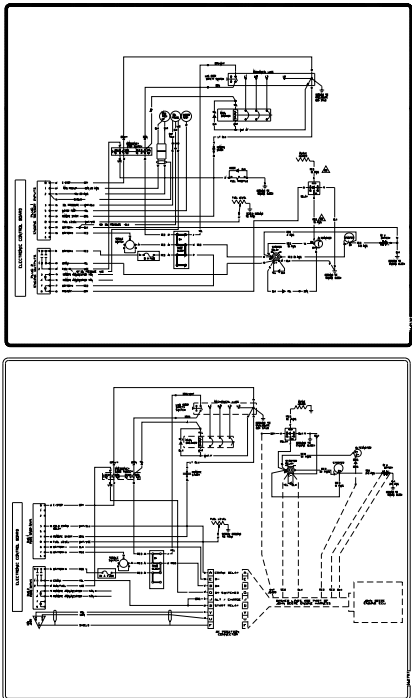
Ref.	Label	Meaning								
T		<p>WARNING! Disconnect battery before servicing. Read the Operator's Manual.</p>								
U	<table border="1" style="width: 100%; border-collapse: collapse;"> <thead> <tr> <th style="width: 25%;">TRAILER WIRING</th> <th style="width: 25%;">ANHÄNGER-VERDRÄHTUNG</th> <th style="width: 25%;">CANALISATION ELECTRICA DE REMOLQUE</th> <th style="width: 25%;">DISPOSITION DES CABLES POUR REMORQUE</th> </tr> </thead> <tbody> <tr> <td style="font-size: small;"> G - RIGHT BRAKE LIGHT AND DIRECTIONAL Y - LEFT BRAKE LIGHT AND DIRECTIONAL Br - TAIL, SIDE AND LICENSE PLATE LIGHTS W - GROUND L - ELECTRIC BRAKES B - BATTERY CHARGE </td> <td style="font-size: small;"> G - RECHTES BREMSLICHT UND BLINKER Y - LINKES BREMSLICHT UND BLINKER Br - SCHLUSS-, SEITEN- UND KENNZEICHENLEUCHTE W - ERDUNG L - ELEKTRISCHE BREMSE B - BATTERIE-LADUNG </td> <td style="font-size: small;"> G - LUZ FRENO Y GIRO DERECHA Y - LUZ FRENO Y GIRO IZQUIERDA Br - LUZ TRASERA, LATERAL Y PLACA DE MATRICULA W - TIERRA L - FRENO ELECTRICOS B - CARGA BATERIA </td> <td style="font-size: small;"> G - FEUX DE STOP ET DE DIRECTION D Y - FEUX DE STOP ET DE DIRECTION G Br - FEUX D'ARRIERE, DE POSITION ET DE PLAQUE D'IMMATRICULATION W - MISE A TERRE L - FREINS ELECTRIQUES B - CHARGE DE LA BATTERIE </td> </tr> </tbody> </table>	TRAILER WIRING	ANHÄNGER-VERDRÄHTUNG	CANALISATION ELECTRICA DE REMOLQUE	DISPOSITION DES CABLES POUR REMORQUE	G - RIGHT BRAKE LIGHT AND DIRECTIONAL Y - LEFT BRAKE LIGHT AND DIRECTIONAL Br - TAIL, SIDE AND LICENSE PLATE LIGHTS W - GROUND L - ELECTRIC BRAKES B - BATTERY CHARGE	G - RECHTES BREMSLICHT UND BLINKER Y - LINKES BREMSLICHT UND BLINKER Br - SCHLUSS-, SEITEN- UND KENNZEICHENLEUCHTE W - ERDUNG L - ELEKTRISCHE BREMSE B - BATTERIE-LADUNG	G - LUZ FRENO Y GIRO DERECHA Y - LUZ FRENO Y GIRO IZQUIERDA Br - LUZ TRASERA, LATERAL Y PLACA DE MATRICULA W - TIERRA L - FRENO ELECTRICOS B - CARGA BATERIA	G - FEUX DE STOP ET DE DIRECTION D Y - FEUX DE STOP ET DE DIRECTION G Br - FEUX D'ARRIERE, DE POSITION ET DE PLAQUE D'IMMATRICULATION W - MISE A TERRE L - FREINS ELECTRIQUES B - CHARGE DE LA BATTERIE	
TRAILER WIRING	ANHÄNGER-VERDRÄHTUNG	CANALISATION ELECTRICA DE REMOLQUE	DISPOSITION DES CABLES POUR REMORQUE							
G - RIGHT BRAKE LIGHT AND DIRECTIONAL Y - LEFT BRAKE LIGHT AND DIRECTIONAL Br - TAIL, SIDE AND LICENSE PLATE LIGHTS W - GROUND L - ELECTRIC BRAKES B - BATTERY CHARGE	G - RECHTES BREMSLICHT UND BLINKER Y - LINKES BREMSLICHT UND BLINKER Br - SCHLUSS-, SEITEN- UND KENNZEICHENLEUCHTE W - ERDUNG L - ELEKTRISCHE BREMSE B - BATTERIE-LADUNG	G - LUZ FRENO Y GIRO DERECHA Y - LUZ FRENO Y GIRO IZQUIERDA Br - LUZ TRASERA, LATERAL Y PLACA DE MATRICULA W - TIERRA L - FRENO ELECTRICOS B - CARGA BATERIA	G - FEUX DE STOP ET DE DIRECTION D Y - FEUX DE STOP ET DE DIRECTION G Br - FEUX D'ARRIERE, DE POSITION ET DE PLAQUE D'IMMATRICULATION W - MISE A TERRE L - FREINS ELECTRIQUES B - CHARGE DE LA BATTERIE							
V		<p>Operator's Manual must be stored on machine. Replacement Operator's Manual can be ordered through your local Wacker distributor.</p>								
W		<p>Drain containment system.</p>								
X		<p>WARNING! To prevent hearing loss, wear hearing protection when operating the machine. WARNING! Pressurized contents. Do not open when hot! WARNING! Hand injury if entangled in moving belt. WARNING! Rotating machinery! Do not reach inside with engine running.</p>								
Y		<p>Operating the main circuit breaker supplies or interrupts power to the customer connection lugs.</p>								

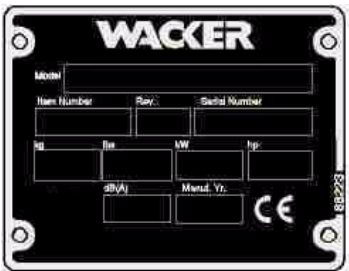
Ref.	Label	Meaning
Z		Neutral bonded to frame.
AA		<p>Fuses</p> <p>Read the operator's manual for machine information.</p> <ul style="list-style-type: none"> 1 - Controller 2 - Not used 3 - Not used 4 - Not used
BB		<p>WARNING!</p> <p>Electric shock at cooling fins.</p>
CC		<p>G 50 / G 70 / G 85</p> <p>Generator and Receptacle Wiring</p>

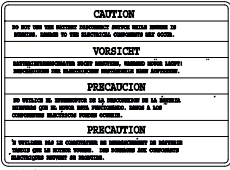
Ref.	Label	Meaning
DD		<p>Engine Wiring</p> <ul style="list-style-type: none"> • G 50/ G 70 <p>Engine Wiring</p> <ul style="list-style-type: none"> • G 70 with electronic control unit (ECU) • G 85
EE		<p>WARNING! Hot surface!</p>
FF		<p>A nameplate listing the model number, item number, revision number, and serial number is attached to each unit. Please record the information found on this plate so it will be available should the nameplate become lost or damaged. When ordering parts or requesting service information, you will always be asked to specify the model number, item number, revision number, and serial number of the unit.</p>

Ref.	Label	Meaning
GG		<p>CAUTION: Do not use battery disconnect switch while engine is running. Damage to electrical components may occur.</p>
		<p>This machine may be covered by one or more patents.</p>
		<p>Certification Label (VIN Number) Also attached to each unit is a Certification Label. This label specifies that the trailer conforms with all Federal Motor Vehicle Standards in effect at the time of manufacture. The label includes the Vehicle Identification Number (VIN) for the trailer.</p>

2. Theory of Operation

2.1 Basic Schematic

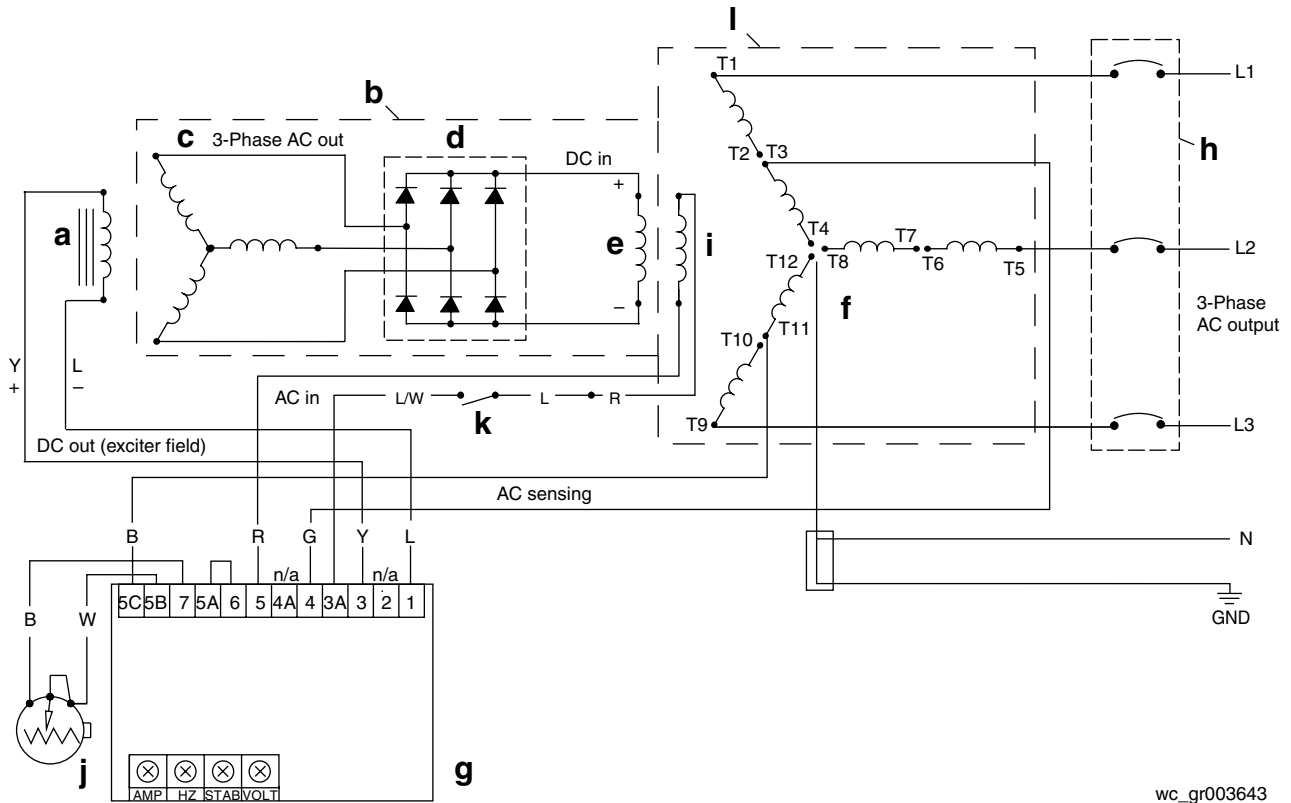

wc_gr003643

Ref.	Component	Ref.	Component
a	Exciter stator winding	g	Automatic Voltage Regulator (AVR)
b	Rotor assembly	h	Main circuit breaker
c	Exciter rotor winding	i	Auxiliary winding
d	Rotating rectifier (diodes)	j	Voltage adjusting Rheostat
e	Main rotor winding	k	Lug door switch
f	Main stator windings	l	Stator assembly

2.2 Introduction

See Graphic: *wc_gr003303*

A generator set is a transducer, which means it converts energy from one form (heat) into another (electrical). The two main components of a generator set are the prime mover (engine) and the generator assembly. The engine converts heat into rotating mechanical energy which is then converted by the generator assembly into electrical energy. The generator does so through the principle of electromagnetic induction. This principle states that when a coil of wire (also known as a winding) is passed through a magnetic field, a voltage is induced in the winding. The amount of voltage depends on three factors: 1) the speed of the coil cutting through the magnetic field (it does not matter which is moving—either the magnetic field or the winding); 2) the strength of the magnetic field; and 3) the amount of turns of wire in the winding. The principle also works in reverse; that is, if a voltage and current is present in a coil of wire, a magnetic field is produced. It is important to understand this basic theory to understand how the generator functions.

The typical brushless generator assembly consists of a stator (stationary element), a rotor (rotating element), a voltage regulator (voltage control device), and a rectifier assembly (current control device). The rotor can function as either the magnetic field or the winding. Likewise, the stator can function as either the magnetic field or the winding, depending on the application. In Wacker generators there are two stators (**a** and **b**) and a single rotor assembly (**c**). The rotor assembly is made up of two halves—the exciter (**d**) and the main (**e**). Three windings make up the exciter half and a single winding makes up the main rotor half. There are three distinct stator windings—the exciter, the main, and the auxiliary. The exciter stator winding (**a**) is a stand alone winding. The main and auxiliary windings are housed within the large stator housing (**b**).

The exciter stator is the generator's source of residual magnetism. As the engine spins, the exciter rotor portion of the rotor assembly spins inside the exciter stator, an AC voltage is induced in the exciter rotor. This AC voltage is rectified into DC by the diodes (**f**) connected to the rotor assembly. The DC voltage flows through the main rotor winding creating a magnetic field. Voltage is then induced in the main stator windings and the auxiliary winding. The voltage induced in the main stator windings provides the voltage to the lugs and the receptacles. The voltage induced in the auxiliary winding is used to power the voltage regulator.

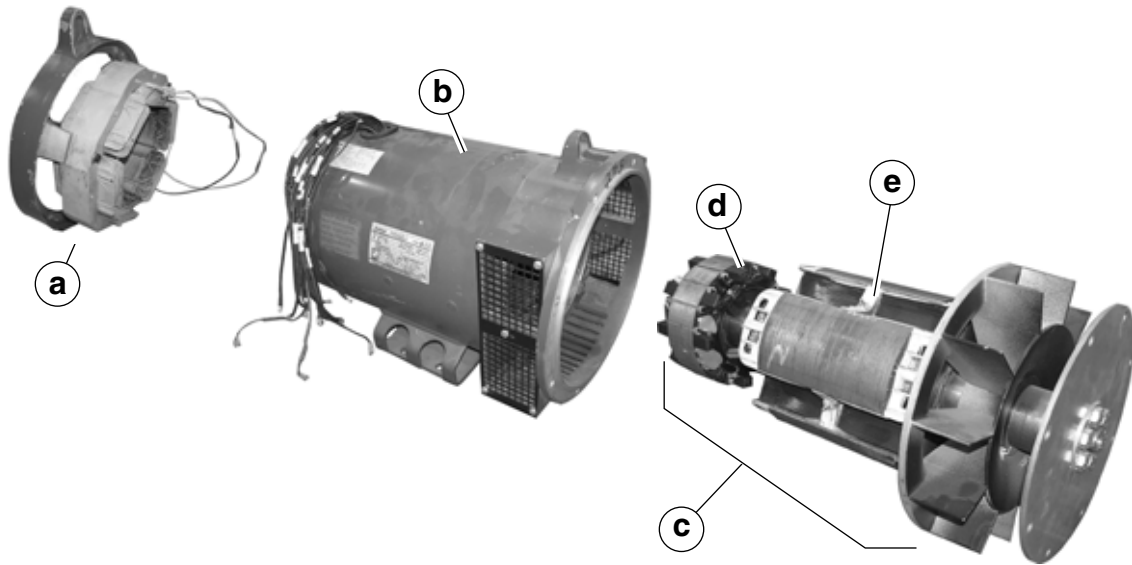
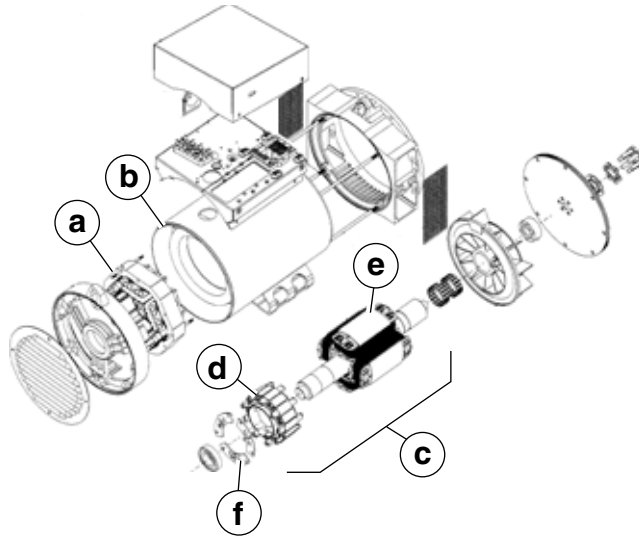

wc_gr003303

2.3 Terminology

See Graphic: *wc_gr003315*

To understand the terms “phase”, “leg”, “line-to-line”, and “line-to-neutral”, review the following information.

- The main stator (**a**) is made of three separate groups of windings. These groups of windings are referred to as legs. The legs are labeled L1, L2, and L3. Each leg includes two individual windings. The ends of these windings are labeled T1, T2, T3, and so on, up to T12.
- Each individual winding has the same resistance (0.2 Ohms). The voltage selector switch determines how the windings are connected—in series or parallel. In series, the total voltage of a leg is equal to the sum of the voltages induced across both windings. In parallel, the total voltage of a leg is equal to the voltage induced across either winding (only one).
- Each leg (L1, L2, and L3) is physically 120° from each other.
- The main rotor (**b**) functions as a rotating magnetic field. It has four poles, two of which function as North and the other two as South.
- “Flux” is a term used to describe the amount of magnetic field in a given area. The term “lines of flux” refers to the direction of the attraction of the magnetic fields—North to South. The point where these lines of flux are closest to 90° is the point where the magnetic field is the strongest, i.e., at either pole. The lines of flux (**c**) of the main rotor’s magnetic field are as shown. When the windings of the stator cut these lines of flux, voltage is induced in them. The amount of induced voltage is greatest at the position where the stator winding is perpendicular to the lines of flux, i.e., when the rotor is in such a position that the windings of a leg are centered over one of the four magnetic poles.
- When the two windings of each leg are connected in series, this is the high-wye configuration (**e**). The voltage induced in this configuration is 277V per leg. When the two windings of each leg are wired in parallel, this is the low-wye configuration (**f**). The voltage induced in this configuration is 139V per leg. (It is adjusted to a usable 120V by the control panel rheostat.)
- The amount of voltage induced in each leg over time can be graphed. This graph yields a sine wave (**d**). It represents the repeating event (cycle) of the induced positive voltage of the North pole followed by the induced negative voltage of the South pole. Since the rotor has four magnetic poles, this cycle occurs twice per revolution of the rotor.
- The engine spins the rotor at 1800 rpm which equals 30 revolutions per second (rps) ($1800/60=30$). The number of revolutions per second multiplied by the cycles per revolution (cpr) equals the cycles per second (Hertz). Thus, $30 \text{ rps} \times 2 \text{ cpr} = 60 \text{ Hz}$.

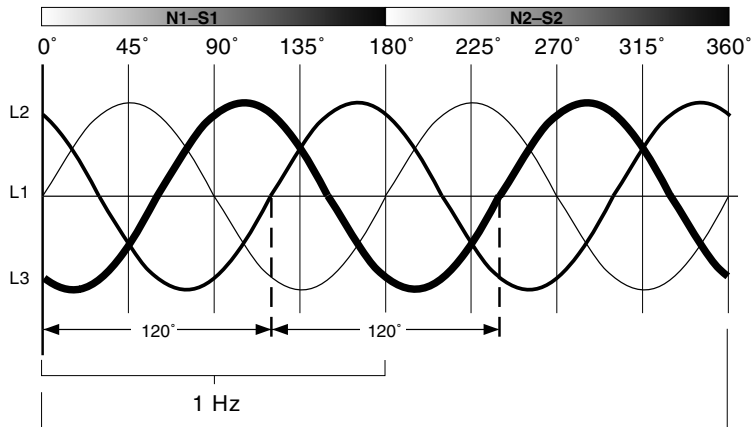
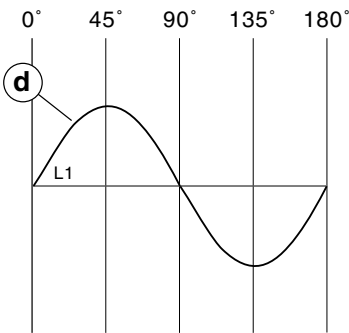
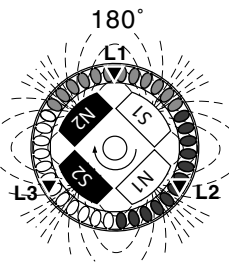
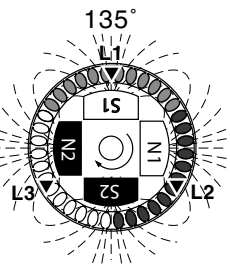
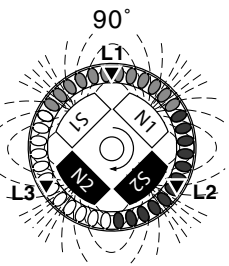
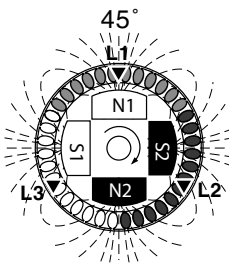
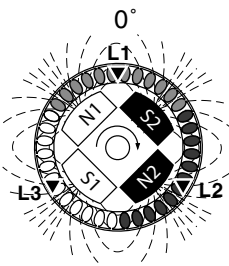
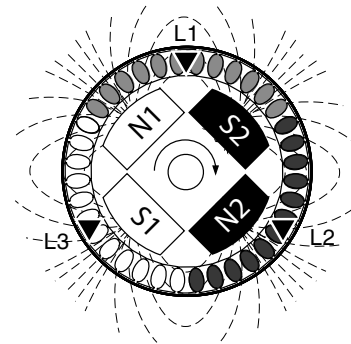
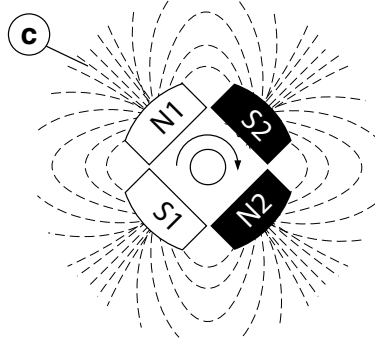
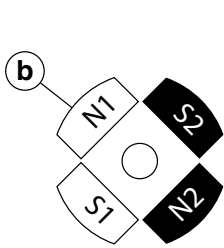
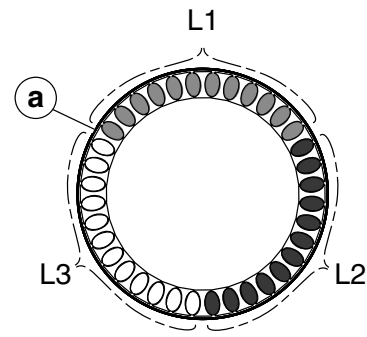
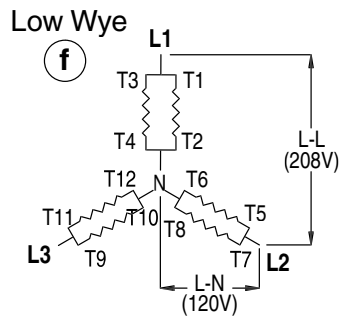
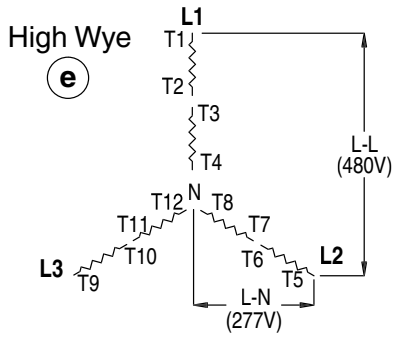

1 Rev

wc_gr003315

- Since the legs are mechanically 120° apart, as the rotor spins, time elapses between the moment when one leg reaches its largest voltage potential and the moment when the next leg reaches its largest voltage potential. Thus, no two legs reach their largest voltage potential at the same moment in time, and their corresponding sine waves are 120° apart. In other words, the voltages induced in each leg are 120° out of phase with each other.
- Although the largest amount of voltage induced in any single leg in the high-wye configuration is 277V, the voltage induced in a second leg (either of the other two legs) at that same moment can be tapped and combined with the 277V of the first leg to create the maximum voltage available from the generator. The amount of voltage in the second leg is less than its largest potential because of the position of the rotor's magnetic field—it is less than perpendicular to the second leg. The amount of voltage induced is approximately 73% (203V) of its potential (see graphic wc_gr003317). Thus, 277V + 203V = 480V, which is the maximum voltage available from the generator. In the low-wye configuration, the largest usable voltage potential in any leg is 120V; adding the 73% of any second leg (88V), yields the maximum voltage potential for the low-wye configuration—208V.
- Any measurement between the end of a leg and neutral is known as line-to-neutral (L-N) voltage. Any measurement between the end of one leg to the end of another leg is known as line-to-line (L-L) voltage. Any combination of L-N or L-L voltages are 120° out of phase with each other. For example, L1–N is out of phase with L2–N; L2–N with L3–N; L3–N with L1–N. Likewise, L1–L2 is out of phase with L2–L3; L2–L3 with L3–L1; and L2–L3 with L1–L2.
- A three-phase event exists when a three-phase load is attached to the generator. The three-phase load uses both the voltage and current from each phase produced by the generator simultaneously. Positive current produced by the voltage from each leg flows to corresponding legs of the load.

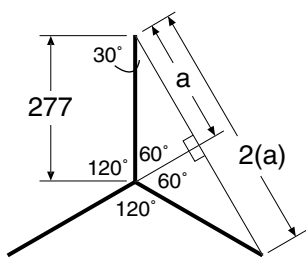

$$\begin{aligned} \text{Sine } 60 &= 0.866 \\ \text{Sine } 60 &= a/277 \\ 0.866 &= a/277 \\ 277 \times 0.866 &= (a/277) \times 277 \\ 240 &= a \\ 2(a) &= 480 \\ 480 - 277 &= 203 \\ 203/277 &= 0.73 = 73\% \end{aligned}$$

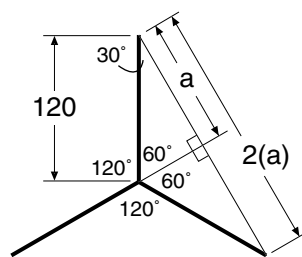

$$\begin{aligned} \text{Sine } 60 &= 0.866 \\ \text{Sine } 60 &= a/120 \\ 0.866 &= a/120 \\ 120 \times 0.866 &= (a/120) \times 120 \\ 104 &= a \\ 2(a) &= 208 \\ 208 - 120 &= 88 \\ 88/120 &= 0.73 = 73\% \end{aligned}$$

wc_gr003317

- Power factor refers to efficiency. It is the relationship between power supplied to the load (referred to as apparent power in kVA) and true power (power consumed by the load (kW)). The power factor is determined by the type of load—inductive or resistive. Inductive loads such as motors and transformers produce a counter Electro Motive Force (EMF) (voltage) simply by the nature of the induction process—any time a coil cuts a magnetic field, induction occurs producing a counter EMF. The generator must produce enough power to overcome the counter EMF plus the power consumed by the motor (true power). Thus, $\text{apparent power} = \text{usable power} + \text{EMF}$, and $\text{power factor} = \frac{\text{true power}}{\text{apparent power}}$. Wacker generators are designed to accommodate loads with a power factor of 0.8. Wacker Mobile Generators are rated by apparent power. A G 25 model can handle true power loads up to 20.4 kW.
- Single-phase receptacles are tapped off the legs in a manner that keeps the generator balanced. That is, voltage supplies to the various single-phase outlets originate from different legs of the generator (L1 and L3), not from the same leg. When tapping single-phase loads from the lugs, care must be taken so that the generator does not become unbalanced. Attach equal loads to each leg if you are running the generator in this manner.

2.4 Generator Systems

The generator can be divided into four basic systems:

- 1) Power Generation and Output. This system includes the generator, voltage selector switch, receptacles, customer connect lugs and circuit breakers.
- 2) Voltage Regulation. Consisting primarily of the voltage regulator and exciter field winding, this system controls the voltage output of the generator.
- 3) Engine Start. This system includes the relays and solenoids needed to start the engine. This system is activated by the ECM.
- 4) ECM Monitoring System. This system monitors the engine and generator functions during operation. It includes the current transformers and engine sensors. It responds to possible malfunctions by closing the engine fuel valve to shut down the engine.

2.5 Power Generation & Output

General Operation

The exciter stator is designed to be the primary source of the generator's residual magnetism. When the machine's engine is first started, this residual magnetism induces a small AC voltage and current in the exciter rotor as it rotates inside the exciter stator. The three-phase AC voltage and current generated in the exciter rotor is rectified to DC by a three-phase full wave rotating rectifier mounted on the end of the rotor assembly. This rectified DC voltage and current flow through the main rotor windings and create the initial magnetic field buildup (excitation) on the rotor.

As the main rotor field turns, a low residual voltage is induced in the generator's main stator windings. This residual voltage and current activate the automatic voltage regulator via the sensing/power wires which are connected to a specific points of the main stator windings. The voltage regulator sends DC voltage to the exciter stator which increases the induced voltage and current to the exciter rotor windings thus allowing the generator to build up to its rated voltage.

The voltage regulator senses the load on the generator via leads on the main stator windings. During operation, it continues to control the input voltage to the exciter field through wires F- (blue) and F+ (yellow). As the load on the generator increases, the voltage regulator increases DC voltage to the exciter field and thus maintains the desired output voltage on the main stator windings.

See Graphic: *wc_gr003283*

Voltage Selector Switch (VSS)

The VSS changes connections between the six main windings to form three different configurations:

- High Wye (480/277V 3Ø)
- Low Wye (208/120V 3Ø)
- Zig-Zag (240/120V 1Ø)

The main stator windings connect to one side of the VSS at the terminals. Output leads from the other side of the VSS are directed through the current transformers and then to both the main circuit breaker and the receptacles. With the breaker(s) closed, the appropriate voltage is supplied to the main connection lugs and receptacles.

During normal operation, each of the six windings on the main stator will develop between 120–139VAC. The exact voltage depends on the setting of the voltage selector switch and the voltage adjustment rheostat. The ends of each winding are identified as: T1–T2, T3–T4, T5–T6, T7–T8, T9–T10, T11–T12.

The voltage selector switch connects the six main stator windings together into the three configurations shown in the chart. (A similar chart is also found on the lug door.) Inter-winding connections are made by internal switch contacts.

For example, in the 480/277V, three-phase position, the VSS will make the following connections:

$$T1-T2 + T3-T4 = L1$$

$$T5-T6 + T7-T8 = L2$$

$$T9-T10 + T11-T12 = L3$$

This connects the main windings into the high-wye configuration shown in the chart, and provides 277VAC when measured line-to-neutral and 480VAC measured line-to-line.

Similar connections are made for the other two positions of the voltage selector switch.

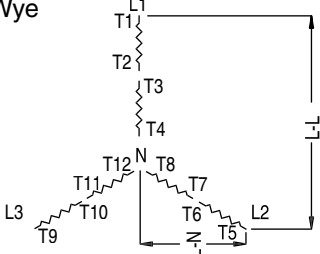
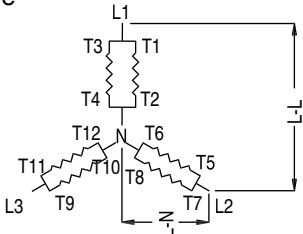
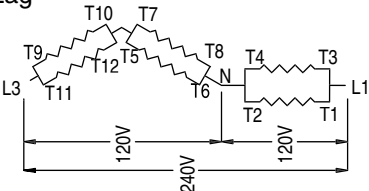
<p>High Wye</p>  <p> $L1-L2 = 480V$ $L1-N = 277V$ $L2-L3 = 480V$ $L2-N = 277V$ $L3-L1 = 480V$ $L3-N = 277V$ </p> <p>N</p>	<p>20A GFI</p> <p>*139V</p>	<p>30A Twist lock</p> <p>*139/240V</p>	<p>50A Twist lock</p> <p>*139/240V</p>
<p>Low Wye</p>  <p> $L1-L2 = 208V$ $L1-N = 120V$ $L2-L3 = 208V$ $L2-N = 120V$ $L3-L1 = 208V$ $L3-N = 120V$ </p> <p>N</p>	<p>120V</p> <p>or</p> <p>*139V</p>	<p>120/208V</p> <p>or</p> <p>*139/240V</p>	<p>120/208V</p> <p>or</p> <p>*139/240V</p>
<p>Zig Zag</p>  <p> $L1-L2 = 240V$ $L1-N = 120V$ $L3-N = 120V$ </p>	<p>120V</p>	<p>120/240V</p>	<p>120/240V</p>

wc_gr003283

* Do not use GFI receptacles because GFI receptacles are only rated to 135V. Use care when using generator with selector switch in this position; 139V may damage certain tools. If three-phase load can be operated at lower voltage, turn the voltage adjusting rheostat on the control panel down—this will lower the GFI and line-to-neutral voltage as well. For example, 480V turned to 460V also reduces the GFI voltage from 139V to 133V.

See Graphic: wc_gr003304

Terminal Lugs and Receptacles

The main connection lugs, labeled L1, L2, L3, and N are connected through the main circuit breaker (b) and then the voltage selector switch (a), and back to the main stator windings. These lugs provide the primary connection points for attachment of outside loads. Power to the receptacles (c and d) is provided by line connections originating from the T3 and T11 (T7 and T9 on older machines) leads from the VSS/generator. The leads connect to the terminal block (g) (R1 and R2) from which wires of lesser gauge feed the individual circuit breakers (e and f).

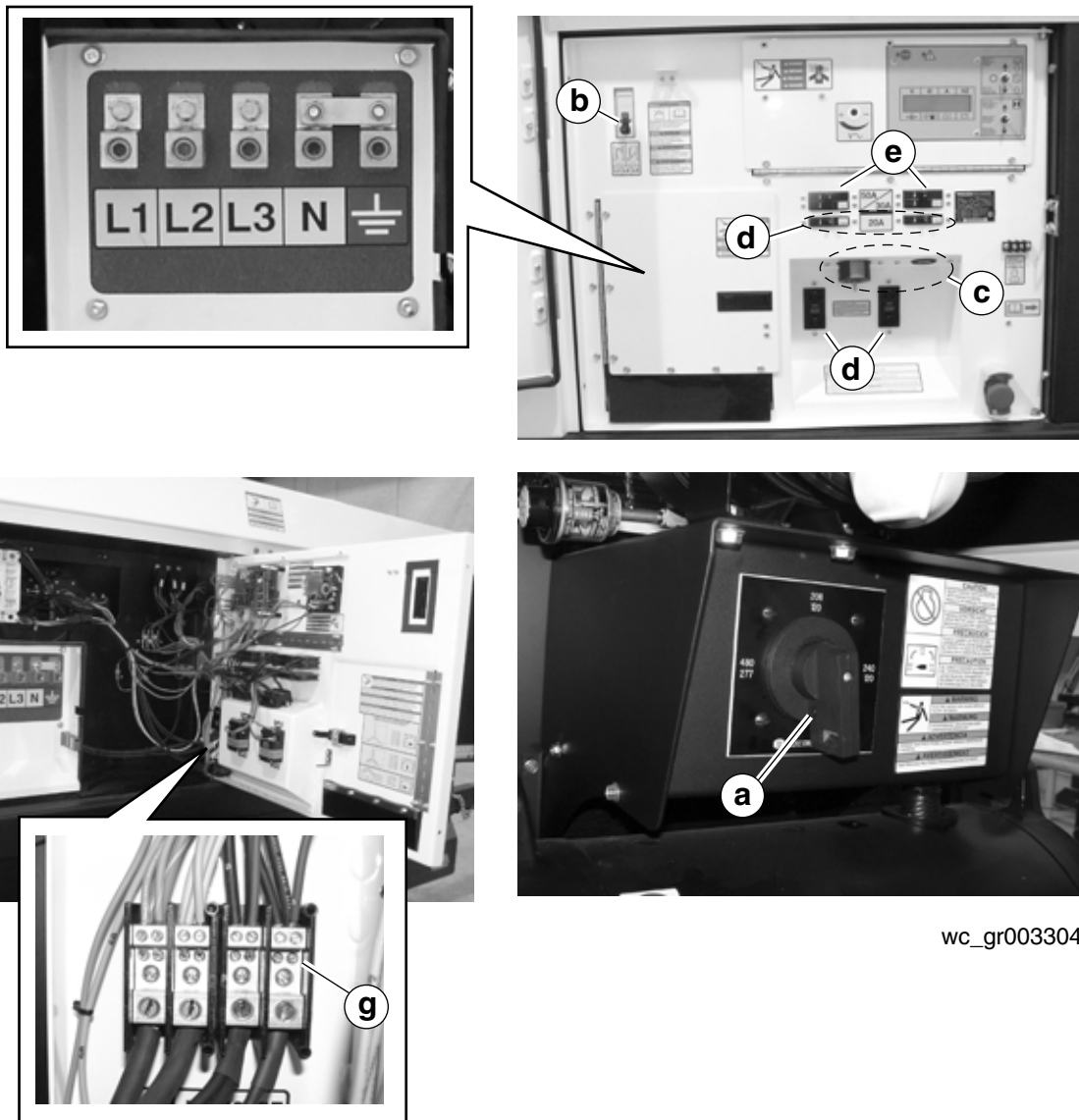

wc_gr003304

2.6 Voltage Regulation

See Graphic: *wc_gr003305*

The Automatic Voltage Regulator (AVR) **(a)** is an encapsulated electronic control device that is rectangular in shape and located inside the control box. Its function is to maintain constant generator voltage over varying load conditions. The AVR controls generator voltage by sensing AC voltage from the main stator winding at terminals 3 and 11 (3 and 4 on older machines). The voltage is passed through a full-wave rectifier to supply DC output at the field terminals 3 (F+) and 1 (F-). The DC output controls the field strength of the exciter stator winding. A 5A, 250V, 5 x 20 mm, fuse **(b)** protects the regulator. The regulator will not work if the fuse is bad or missing.

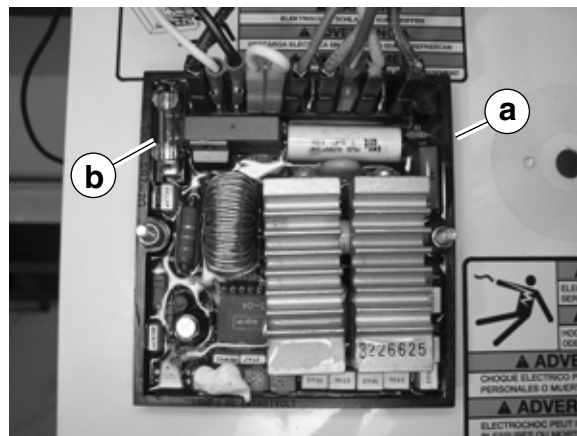

wc_gr003305

See Graphic: *wc_gr0003305*

Regulator Makeup

There are twelve terminals on the regulator labeled 1, 2, 3, 3A, 4, 4A, 5, 6, 5A, 7, 5B, 5C.

- Terminals 1, 2 and 3

These three terminals are used for output DC voltage to the exciter stator winding. Terminal 1 is for DC negative, terminal 2 is not used in Wacker generators, terminal 3 is for DC positive. The DC voltage is used to strengthen the magnetic field in the exciter stator.

- Terminals 3A and 5

These two terminals are used for input AC voltage to the AVR generated by the auxiliary winding.

- Terminals 4 and 5c

These two terminals are used for sensing stator voltage. The green and black wires are connected to T3 and T4 (or T11) respectively.

- Terminals 5A and 6
These two terminals are jumpered together in 60Hz applications.
- Terminals 5B and 7
These two terminals are connected to the voltage adjustment rheostat via the black and white wires.
- Pots “Volt” and “Stab”

On the backside of the regulator there are several adjustment pots. On Wacker generators only two of the pots are used. They are the Volt and Stab pots. The Volt pot is used in conjunction with the front panel rheostat to calibrate the usable voltage.

The Stab pot is used to increase or decrease the regulator response time to load changes (transients). If the Stability (Stab) is set too low, the regulator can begin to hunt or cycle the DC output voltage up and down. This will cause the generator AC voltage to cycle up and down (as seen in job lights flickering, etc.).

Note: *The Stab pot is factory set. Under normal circumstances, no adjustments to the Stab pot is necessary. Only adjust the Stab pot if a problem is present.*

See Graphic: *wc_gr003306*

Voltage Adjusting Rheostat (100k or 150k Ohms)

Generator output voltage can be adjusted using the rheostat **(a)**. The rheostat is not part of the voltage regulator. It is connected to the regulator at terminals 5B and 7. The voltage adjustment range is +10% to -10% of the selected voltage.

NOTICE: Do not turn the voltage beyond 490VAC; damage to the excitation circuit will occur.

Note: *It will be necessary to adjust the voltage every time the voltage selector switch is changed to or from the 208V position.*

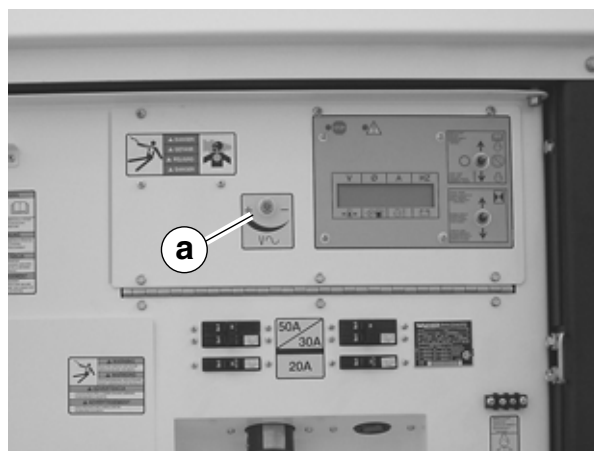

wc_gr003306

2.7 Engine Start

Battery B+ wires provide 12VDC to the following locations on each generator:

- Isuzu-powered generators: starter motor, glow plug relay, and terminal strip.
- John Deere without Engine Control Unit (ECU): starter motor, starter relay, terminal strip, alternator, and preheat relay.
- John Deere with ECU: ECU and terminal strip.

Engine Start Switch

In the START/RUN position the engine start switch supplies power to the ECM through red wire #53. This causes the module to go through its boot-up sequence which includes self-diagnostic checks, activation of the sensing circuits, and illumination of the display panel.

Engine Control Module (ECM) Relays

The ECM contains crank, fuel, and preheat relays (not included on generators powered by John Deere engines with ECU). Red wire #18 connected to plug 2, pin 5 on the ECM provides 12VDC supply to contacts of the fuel and crank relays. This circuit is protected by a 10A fuse. Red wire #17 connected to plug 2, pin 7 on the ECM provides 12VDC to the contacts of the preheat relay.

When the start switch is in the START/RUN position, the ECM's crank relay is energized. On all models, the crank relay supplies 12VDC through yellow wire #63 to energize the starter relay. When the starter relay energizes, it supplies battery power to the engine starter motor solenoid which engages the starter motor to crank the engine. The crank relay on the ECM remains energized for 10 seconds or until either the magnetic pick-up on the engine flywheel signals 100 rpm or the AC voltage input reaches 100VAC signifying the engine has started.

When the start switch is in the START/RUN position, the ECM's fuel relay is also energized. On Isuzu-powered generators, the ECM fuel relay supplies 12VDC through violet wire #64/#34 to energize the fuel pump relay. On John Deere (without ECU) powered generators, the ECM fuel relay supplies 12VDC through violet wire #64/#34 to energize the fuel solenoid. On John Deere (with ECU) powered generators, the ECM fuel relay supplies 12VDC through violet wire #64/#34 to power the ECU control circuits.

In the START/RUN position the ECM preheat relay will energize on the first of the three cranking cycles if coolant temperature (fuel temperature on John Deere powered generators) dictates. The ECM preheat relay supplies 12VDC through gray wire #65 to the glow plug relay on Isuzu-powered generators, and the intake air heater relay on John Deere (without ECU) powered generators. On John Deere engines with ECU, the ECU controls power to the intake air heater relay.

Alternator

On Isuzu-powered generators, the alternator is connected to the battery at the B+ terminal of the starter motor. On John Deere powered generators, the alternator is connected to the battery at the starter relay. The alternator supplies charging current to the battery while the engine is running.

2.8 ECM Monitoring System

Operation

The ECM contains a microprocessor that monitors the engine safety inputs. It protects the engine by automatically shutting it down in the event of low oil pressure, high coolant temperature, high engine speed, or low engine speed. The ECM is programmed at the factory and does not require any adjustment. The ECM also receives voltage and amperage input values from the generator and converts them to the digital readout displayed on its LCD panel. The ECM also monitors the current draw from the generator and will stop the engine if an overload is detected.

Power Supply

When the engine start switch is switched to START/RUN or REMOTE START, 12VDC is applied to the ECM through the red wire connected to plug 1, pin 7. This is the main power supply to the ECM board. Electrical ground to the ECM is located at pin 8, next to pin 7.

Oil Pressure

The ECM begins monitoring oil pressure 12 seconds after the engine starts and continues to monitor pressure until the engine is shutdown. On early generators the sensor is a variable resistor; later generators the sensor creates a millivoltage as pressure changes. The ECM monitors via wiring to plug 1, pin 3. If oil pressure falls below 15 psi, the ECM will recognize the fault and open the fuel relay circuit, stopping the engine.

Coolant Temperature

The ECM begins monitoring engine coolant temperature immediately after it runs through its boot-up cycle. The sensor is a variable resistor that the ECM monitors through the yellow wire connected to plug 1, pin 5. The ECM recognizes the fault condition and opens the fuel relay when the engine temperature reaches 239°F (133°C) on John Deere engines and 221°F (123°C) on Isuzu engines. The coolant temperature sensor is located on the engine cylinder head near the thermostat.

Underspeed / Overspeed

Engine underspeed/overspeed protection is monitored from the frequency of an AC voltage generated every time a flywheel tooth passes under the magnetic pickup mounted to the engine flywheel housing. The frequency signal is transmitted to the ECM through the shielded black and clear wires connected to plug 1, pins 1 and 2.

The shutdown trip point is approximately 67Hz (2010 rpm) for overspeed and 55Hz (1650 rpm) for underspeed. If engine speed exceeds 67Hz or falls below 55Hz, the ECM opens the fuel relay circuit and stops the engine.

Overcrank

The frequency signal is also used to determine an overcrank condition. If the ECM does not notice an increase in engine speed after three cycles of 10-seconds of crank followed by 10-seconds of rest, it terminates the crank attempts and displays an OVERCRANK message on the display panel. Placing the START/RUN switch to the OFF position will reset the ECM.

Fuel Gauge

The sensor is a variable resistor that the ECM monitors through the white/violet wire at plug 1, pin 12. If the input resistance climbs too high indicating a fuel level below 5%, the ECM opens the fuel relay circuit, which de-energizes the fuel solenoid and shuts down the engine.

Voltmeter

Line voltage values are transmitted to the ECM through the brown, yellow, and orange wires connected to plug 4. These wires are connected to the voltage selector switch.

See Graphic: wc_gr003307

Current Transformers

Load line current values are provided by three current transformers (CT1, CT2, and CT3). Power lines to the main connection lugs and receptacles run through the current transformers. The current transformers sense line current and send an equivalent voltage to the ECM through the brown, yellow, white, and orange wires connected to plug 3. The ECM translates the incoming voltage into a digital readout showing current values for each phase leg of the generator.

A current overload on any leg will be recognized as a fault and the ECM will shut down the engine.

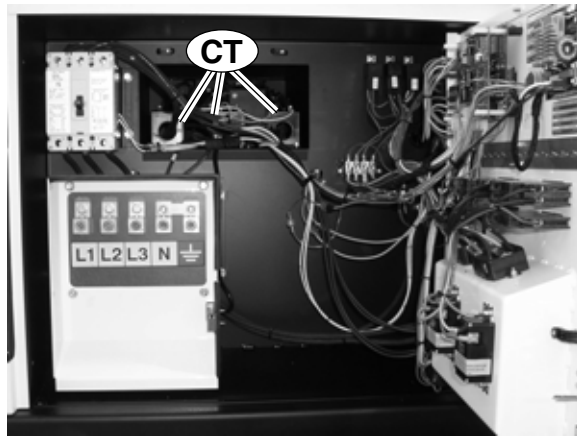

wc_gr003307

Notes

3. Electrical Testing Techniques

3.1 Checking Continuity

Conduct continuity tests when the engine is shut down.

When checking continuity, use the Ohm setting on your multimeter. Place a lead of the multimeter on one end of the wiring or component and the other lead on the opposite end. If your meter reads “OL” or “OPEN”, there is no continuity and the wiring or component must be repaired or replaced.

Note: *Some multimeters also have an audio signal setting for determining continuity. This setting may also be used.*

- If your meter reads less than 1.0 Ohm, or the audio signal sounds, the wiring or component has continuity and should be OK.
- If your meter reads more than 1.0 Ohm, the wiring is faulty and must be repaired or replaced.

3.2 Checking Resistance

Conduct resistance checks when the engine is shut down.

Use the Ohm setting on your multimeter.

Conduct resistance checks when the machine is as close to 21°C (70°F) as possible. Higher temperatures can affect resistance values.

Most digital multimeters have some internal resistance. To obtain your multimeter’s internal resistance, simply cross the two leads of your multimeter and read the display. When conducting a resistance check, subtract your multimeter’s internal resistance from the value you measure to obtain the true resistance of the component you are checking.

3.3 Checking Voltage

Conduct voltage checks when the engine is running.

Use the Volt setting on your multimeter. To prevent damage to your instrument, start with the highest scale available on your multimeter. Adjust to a lower scale as readings dictate.

Use extreme caution when checking voltage to reduce the risk of electric shock.

3.4 Probing ECM Pins and Pins

See Graphic: *wc_gr002926*

To measure the voltage at an ECM pin, attach an appropriate extension **(a)** to the positive probe on your multimeter. Slide the positive probe into the plug along the wire of the pin to be tested. Use care when testing this way so you don't damage the wire, plug, or ECM. Find a suitable ground on the machine's frame for the negative probe **(b)** of your multimeter.

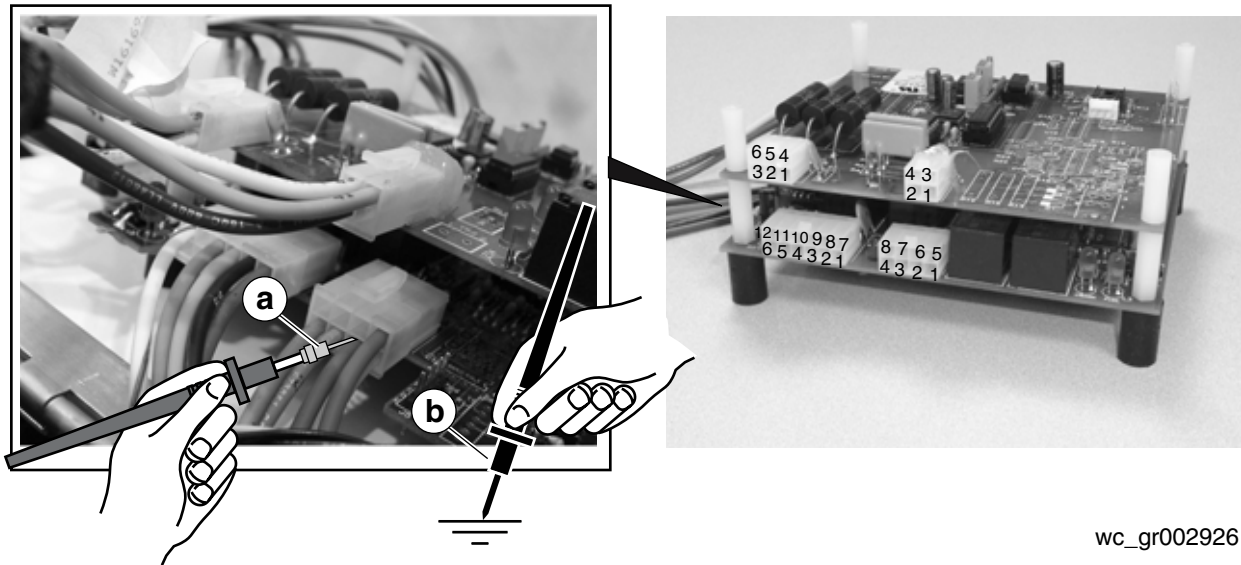

wc_gr002926

4. ECM Background Information

4.1 ECM Handling Precaution

See Graphic:wc_gr003355

NOTICE: Use care when working on or around the ECM. The ECM may be damaged or it may malfunction if it is accidentally hit by your hand or a tool. Do not touch the pins (**a**) of the ECM because the AC board of the ECM may malfunction.

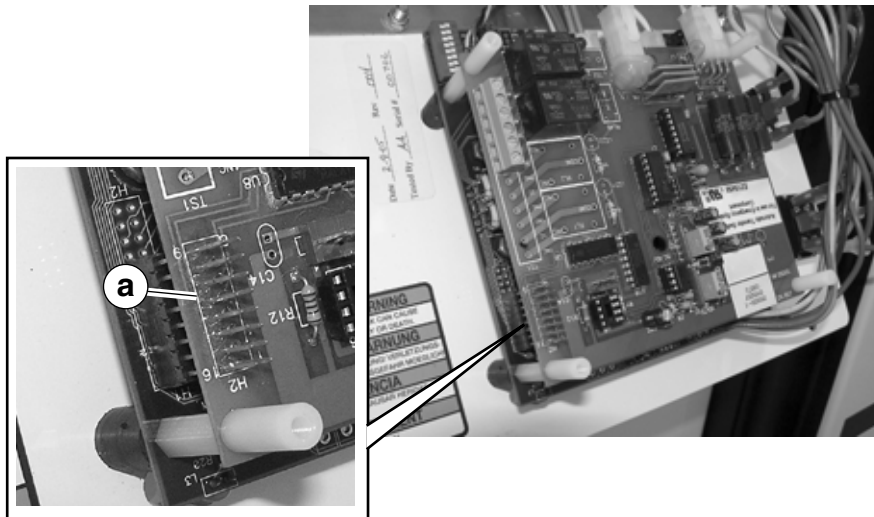

wc_gr003355

4.2 Normal Boot-up Sequence

During the boot-up sequence, the ECM scrolls through several screens before it settles into displaying the run screen. There are two different boot-up sequences depending on size of the generator and options included on the generator. Both of the boot-up sequences are listed below. When checking the boot-up sequence of your generator, be sure you are checking the one that matches your generator.

G 25, G 50, G 70, G 85 (9310)

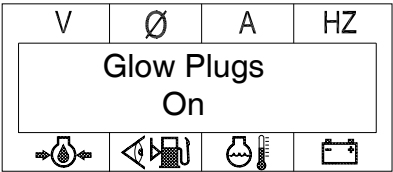
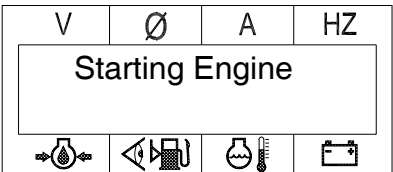
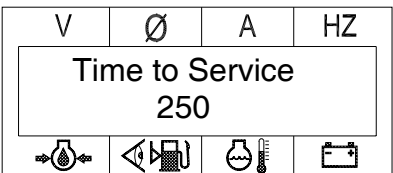
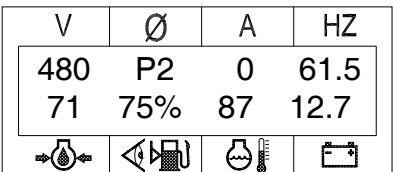
ECM Display	Description
	<p>Start of the boot-up sequence. The ECM shows that the glow plugs are on. The LED near the stop icon also illuminates. Note that the glow plugs are only on during the first of the three starting cycles.</p>
	<p>The ECM displays this screen when the starter is cranking the engine.</p>
	<p>The ECM displays the countdown time, in hours, until the next scheduled service. The timer starts at 250 and counts down to 0.</p>
	<p>At this point, the ECM displays the running values of the generator. Note: <i>The ECM display scrolls through each phase (P1, P2, P3) if in the 3-phase mode, or L1, L3, and L1 + L3 if in the single-phase mode.</i></p>

G 85 (9305), G 125, G 160

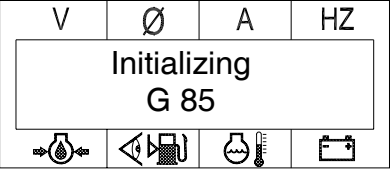
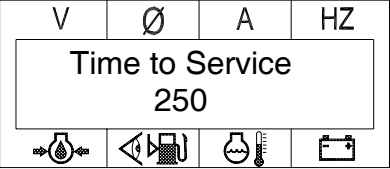
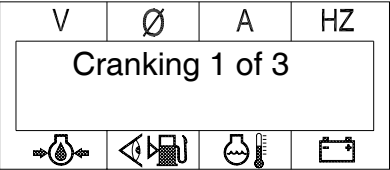
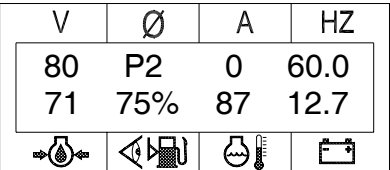
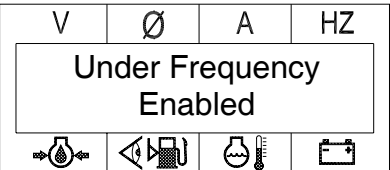
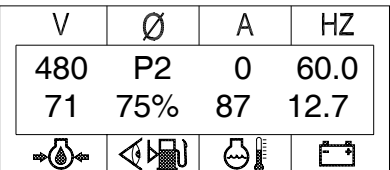
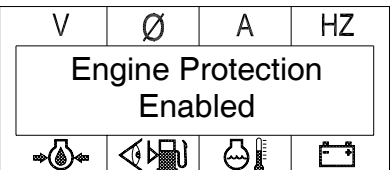
ECM Display	Description
 <p>The display shows a header with 'V', 'Ø', 'A', and 'HZ'. Below it, a box contains 'Initializing' and 'G 85'. At the bottom are four icons: a fuel pump, an oil can, a water level gauge, and a battery.</p>	<p>Start of the boot-up sequence. The ECM display reads “Initializing” and shows the model of the generator. If the model displayed does not match the model of the generator, call Wacker Service.</p>
 <p>The display shows a header with 'V', 'Ø', 'A', and 'HZ'. Below it, a box contains 'Time to Service' and '250'. At the bottom are four icons: a fuel pump, an oil can, a water level gauge, and a battery.</p>	<p>The ECM displays the countdown time until the next scheduled service. The timer starts at 250 and counts down to 0.</p>
 <p>The display shows a header with 'V', 'Ø', 'A', and 'HZ'. Below it, a box contains 'Cranking 1 of 3'. At the bottom are four icons: a fuel pump, an oil can, a water level gauge, and a battery.</p>	<p>The ECM displays this screen during the first cranking cycle.</p>
 <p>The display shows a header with 'V', 'Ø', 'A', and 'HZ'. Below it, two rows of values are shown: '80 P2 0 60.0' and '71 75% 87 12.7'. At the bottom are four icons: a fuel pump, an oil can, a water level gauge, and a battery.</p>	<p>The ECM displays this screen as soon as the engine starts. Note that some of the values such as voltage, may not be up to their running values at this stage of the sequence.</p>
 <p>The display shows a header with 'V', 'Ø', 'A', and 'HZ'. Below it, a box contains 'Under Frequency Enabled'. At the bottom are four icons: a fuel pump, an oil can, a water level gauge, and a battery.</p>	<p>The ECM displays this screen to let the operator know that the under frequency system (engine speed) has been enabled.</p>
 <p>The display shows a header with 'V', 'Ø', 'A', and 'HZ'. Below it, two rows of values are shown: '480 P2 0 60.0' and '71 75% 87 12.7'. At the bottom are four icons: a fuel pump, an oil can, a water level gauge, and a battery.</p>	<p>At this point in the sequence, the ECM displays running values.</p>
 <p>The display shows a header with 'V', 'Ø', 'A', and 'HZ'. Below it, a box contains 'Engine Protection Enabled'. At the bottom are four icons: a fuel pump, an oil can, a water level gauge, and a battery.</p>	<p>The ECM displays this screen to let the operator know that the engine protection system has been enabled.</p>

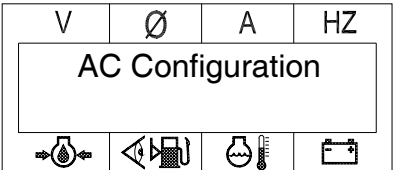
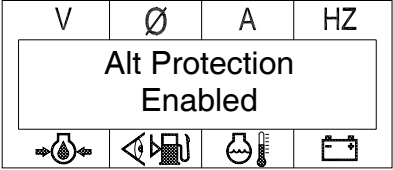
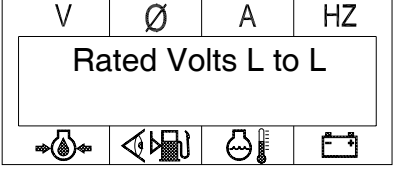
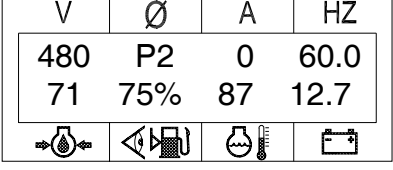
 <p>The image shows a simulated ECM display. At the top, there are four columns labeled 'V', 'Ø', 'A', and 'HZ'. Below these is a large rectangular box containing the text 'AC Configuration'. At the bottom of the display, there are four icons: a light bulb with a double-headed arrow, a fuel tank with a double-headed arrow, a thermometer, and a battery symbol.</p>	<p>The ECM displays the AC configuration as determined by the position of the voltage selector switch (VSS).</p>												
 <p>The image shows a simulated ECM display. At the top, there are four columns labeled 'V', 'Ø', 'A', and 'HZ'. Below these is a large rectangular box containing the text 'Alt Protection Enabled'. At the bottom of the display, there are four icons: a light bulb with a double-headed arrow, a fuel tank with a double-headed arrow, a thermometer, and a battery symbol.</p>	<p>The ECM displays this screen to let the operator know that the alternator protection system has been enabled.</p>												
 <p>The image shows a simulated ECM display. At the top, there are four columns labeled 'V', 'Ø', 'A', and 'HZ'. Below these is a large rectangular box containing the text 'Rated Volts L to L'. At the bottom of the display, there are four icons: a light bulb with a double-headed arrow, a fuel tank with a double-headed arrow, a thermometer, and a battery symbol.</p>	<p>The ECM displays the line-to-line voltage. (This screen is shown for 3-phase VSS positions only.)</p>												
 <p>The image shows a simulated ECM display. At the top, there are four columns labeled 'V', 'Ø', 'A', and 'HZ'. Below these is a table with two rows of data. At the bottom of the display, there are four icons: a light bulb with a double-headed arrow, a fuel tank with a double-headed arrow, a thermometer, and a battery symbol.</p> <table border="1" data-bbox="212 877 570 972"> <thead> <tr> <th>V</th> <th>Ø</th> <th>A</th> <th>HZ</th> </tr> </thead> <tbody> <tr> <td>480</td> <td>P2</td> <td>0</td> <td>60.0</td> </tr> <tr> <td>71</td> <td>75%</td> <td>87</td> <td>12.7</td> </tr> </tbody> </table>	V	Ø	A	HZ	480	P2	0	60.0	71	75%	87	12.7	<p>At this point, the ECM displays the run screen and the values for the main generator variables: voltage, phase* (leg), amperage, hertz (For generators with engines that include ECUs, the Hz reading will be 60.0. For all others the reading will be 61.5.) The ECM will also display the values for the main engine variables: oil pressure, fuel tank quantity, engine temperature, and battery voltage.</p> <p>*Note: The ECM display scrolls through each phase (P1, P2, P3) if in the 3-phase mode, or L1, L3, and L1 + L3 if in the single-phase mode.</p>
V	Ø	A	HZ										
480	P2	0	60.0										
71	75%	87	12.7										

4.3 Display Variables and Values

See Graphic: *wc_gr002944*

- Generator Variables

The values shown in the top line of the ECM display are all variables from the generator side of the machine. They are:

- (1) voltage (V)
- (2) phase (Ø) (or leg for single phase)
- (3) amperage (A)
- (4) frequency (Hz).

- Engine Variables

The values shown in the lower line of the ECM display are all variables from the engine side of the machine. They are:

- (5) engine oil pressure (psi)
- (6) fuel tank quantity (shown in percentage of capacity)
- (7) engine temperature (°F)
- (8) battery voltage (V)

- Blinking Values

When a value on the ECM display blinks on and off, it signifies that the variable (temperature, fuel capacity, etc.) is in a prealarm state. For example, the value for the temperature reading will blink when the temperature of the generator is below 23°C (74°F). This simply signifies that the manifold heater (or glow plugs) will be energized to aid in engine starting. The fuel capacity reading will blink when it is below 25%. This tells the operator that the generator will be requiring fuel soon. See Section *Additional Variables Monitored by the ECM*.

Note: *If your generator has a block heater, the temperature reading should not blink. If it does, check the block heater to make sure it is functioning properly.*

- ND, 0 (zero), or Blank Values

When a value on the ECM display reads ND, 0 (zero), or is blank, it signifies that there is no data available for the variable.

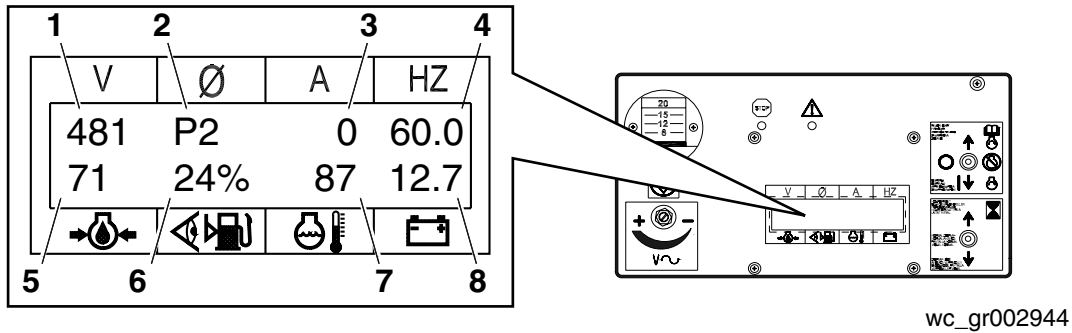

wc_gr002944

4.4 ECM Display Screens—Start Switch in Remote Position

See Graphic: wc_gr002943

When the start switch is placed in the REMOTE position, the following screens are displayed.

- 4.4.1 “Initializing”
The ECM display reads “Initializing” and shows the model of the generator. If the model displayed does not match the model of the generator, call Wacker Service.
- 4.4.2 “Unit in Auto”
The ECM displays “Unit in Auto” and the values for oil pressure, percentage of fuel remaining, engine temperature, and voltage of the battery.





wc_gr002943

4.5 Additional Variables Monitored by the ECM

Holding the toggle switch in the HOURS/RESET position allows the operator to view additional variables monitored by the ECM. It also allows the time-to-service countdown timer to be reset. To reset the countdown timer, hold the toggle switch in the HOURS/RESET position for approximately 30 seconds or until all the screens have been scrolled through twice. There are three different sets of additional variables. Each of the following categories of generators has its own unique set: standard, those generators with cold weather packages or custom features, and those with the John Deere engine that includes the electronic Engine Control Unit (ECU). All three sets of additional variables are listed below, along with typical no load values. **Note:** *The values from your generator may differ slightly from those shown here.*

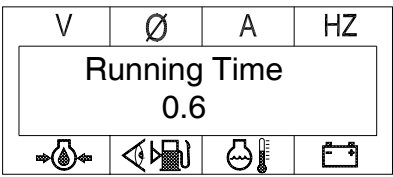
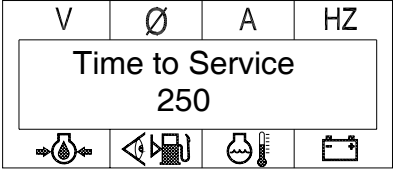
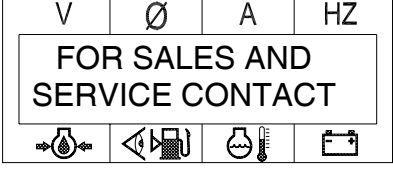
G 25, G 50, G 70, G 85 (9310) Standard Models

ECM Display	Description
	<p>The display shows the amount of time, in 1/10 hour segments, that the engine has been running.</p>
	<p>The display shows the amount of time left until service on the machine is required. To reset the timer to 250 hours, hold the Hours/Reset toggle switch in the up position until all the screens have been scrolled through twice.</p>
	<p>Some ECMs include this message.</p>
	<p>Some ECMs include this message.</p>

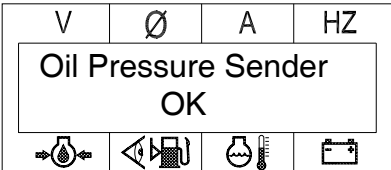
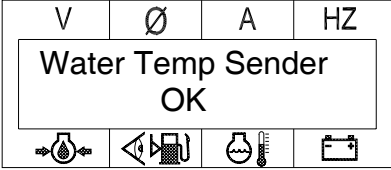
 <p>The display shows the status of the oil pressure sender. If the oil pressure sender has failed, the time of the failure will be displayed. The time of the failure will be included in the display until the generator has been shut down and remains shutdown for a period of approximately two minutes.</p>	<p>The display shows the status of the oil pressure sender. If the oil pressure sender has failed, the time of the failure will be displayed. The time of the failure will be included in the display until the generator has been shut down and remains shutdown for a period of approximately two minutes.</p>
 <p>The display shows the status of the engine coolant temperature sender. If the coolant temperature sender has failed, the time of the failure will be displayed. The time of the failure will be included in the display until the generator has been shut down and remains shutdown for a period of approximately two minutes.</p>	<p>The display shows the status of the engine coolant temperature sender. If the coolant temperature sender has failed, the time of the failure will be displayed. The time of the failure will be included in the display until the generator has been shut down and remains shutdown for a period of approximately two minutes.</p>

G 25, G 50, G 85 (9310) Cold Weather and Custom Generators

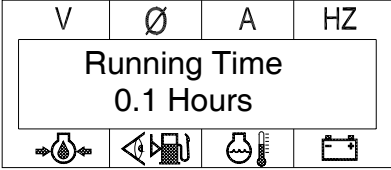
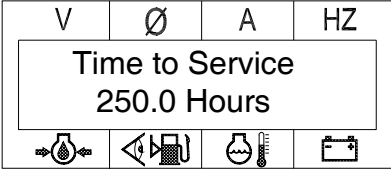
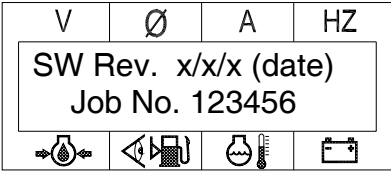
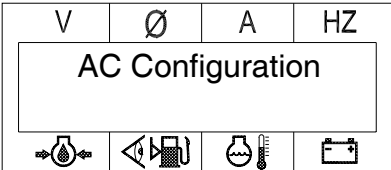
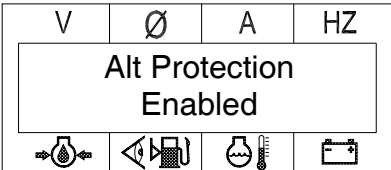
ECM Display	Description
	<p>The display shows the total time, in 1/10 hour increments, that the engine has been run. New machines, or machines with new ECMs, will read 0.0 or “No Data” because the engine has not been run for more than 1/10 of an hour.</p>
	<p>The display shows the amount of time left until service on the machine is required. To reset the timer to 250 hours, hold the Hours/Reset toggle switch in the up position until all the screens have been scrolled through twice.</p>
	<p>The display shows the date and job number data regarding the ECM manufacture.</p>
	<p>The display shows the AC configuration as determined by the position of the Voltage Selector Switch (VSS). If the machine is not running, the display reads “Unknown”.</p>
	<p>The ECM displays this screen to let the operator know that the alternator protection system has been enabled or disabled.</p>

<table border="1"> <tr> <td>V</td> <td>Ø</td> <td>A</td> <td>HZ</td> </tr> <tr> <td colspan="4" style="text-align: center;">Speed Sender Status is Normal</td> </tr> <tr> <td></td> <td></td> <td></td> <td></td> </tr> </table>	V	Ø	A	HZ	Speed Sender Status is Normal								<p>The display shows the status of the speed sender. If the speed sender has failed, the time of the failure will be displayed. The time of the failure will be included in the display until the generator has been shut down and remains shutdown for a period of approximately two minutes. At that time, the ECM clears itself.</p>
V	Ø	A	HZ										
Speed Sender Status is Normal													
<table border="1"> <tr> <td>V</td> <td>Ø</td> <td>A</td> <td>HZ</td> </tr> <tr> <td colspan="4" style="text-align: center;">60.0 Hz Nominal No. Teeth = 142</td> </tr> <tr> <td></td> <td></td> <td></td> <td></td> </tr> </table>	V	Ø	A	HZ	60.0 Hz Nominal No. Teeth = 142								<p>The display shows the number of teeth on the flywheel which are measured by the magnetic pickup. The number of teeth differs between Isuzu engines (136) and John Deere engines (142).</p>
V	Ø	A	HZ										
60.0 Hz Nominal No. Teeth = 142													
<table border="1"> <tr> <td>V</td> <td>Ø</td> <td>A</td> <td>HZ</td> </tr> <tr> <td colspan="4" style="text-align: center;">Prealarm Setting 1 s @ < 55.0 Hz</td> </tr> <tr> <td></td> <td></td> <td></td> <td></td> </tr> </table>	V	Ø	A	HZ	Prealarm Setting 1 s @ < 55.0 Hz								<p>The display shows the value of the prealarm setting for under speed. If the ECM detects that the engine speed is less than 55 Hz for longer than 1 second, the Hz reading on the run screen will start to blink.</p>
V	Ø	A	HZ										
Prealarm Setting 1 s @ < 55.0 Hz													
<table border="1"> <tr> <td>V</td> <td>Ø</td> <td>A</td> <td>HZ</td> </tr> <tr> <td colspan="4" style="text-align: center;">Fault Setting 15 s @ < 55.0 Hz</td> </tr> <tr> <td></td> <td></td> <td></td> <td></td> </tr> </table>	V	Ø	A	HZ	Fault Setting 15 s @ < 55.0 Hz								<p>The display shows the value of the fault setting for under speed. If the ECM detects that the engine speed is less than 55 Hz for longer than 15 seconds, the ECM will shut down the generator.</p>
V	Ø	A	HZ										
Fault Setting 15 s @ < 55.0 Hz													
<table border="1"> <tr> <td>V</td> <td>Ø</td> <td>A</td> <td>HZ</td> </tr> <tr> <td colspan="4" style="text-align: center;">Fault Setting 1 s @ > 67.0 Hz</td> </tr> <tr> <td></td> <td></td> <td></td> <td></td> </tr> </table>	V	Ø	A	HZ	Fault Setting 1 s @ > 67.0 Hz								<p>The display shows the value of the fault setting for over speed. If the ECM detects that the engine speed is more than 67 Hz for longer than 15 seconds, the ECM will shut down the generator.</p>
V	Ø	A	HZ										
Fault Setting 1 s @ > 67.0 Hz													
<table border="1"> <tr> <td>V</td> <td>Ø</td> <td>A</td> <td>HZ</td> </tr> <tr> <td colspan="4" style="text-align: center;">Oil Pres Sender Status is Normal</td> </tr> <tr> <td></td> <td></td> <td></td> <td></td> </tr> </table>	V	Ø	A	HZ	Oil Pres Sender Status is Normal								<p>The display shows the status of the engine oil pressure sender. If the oil pressure sender has failed, the time of the failure will be displayed. The time of the failure will be included in the display until the generator has been shut down and remains shutdown for a period of approximately 2 minutes.</p>
V	Ø	A	HZ										
Oil Pres Sender Status is Normal													
<table border="1"> <tr> <td>V</td> <td>Ø</td> <td>A</td> <td>HZ</td> </tr> <tr> <td colspan="4" style="text-align: center;">Prealarm Setting Level < 20 psi</td> </tr> <tr> <td></td> <td></td> <td></td> <td></td> </tr> </table>	V	Ø	A	HZ	Prealarm Setting Level < 20 psi								<p>The display shows the value of the prealarm setting for low oil pressure. If the ECM detects that the engine oil pressure is less than 20 psi, the engine oil pressure reading on the run screen will start to blink.</p>
V	Ø	A	HZ										
Prealarm Setting Level < 20 psi													

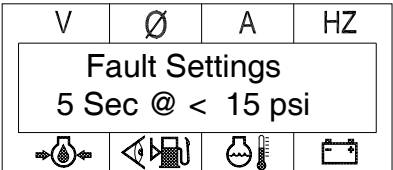
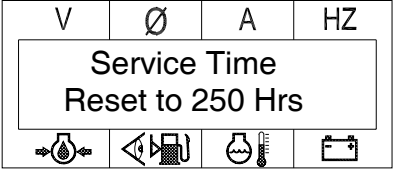
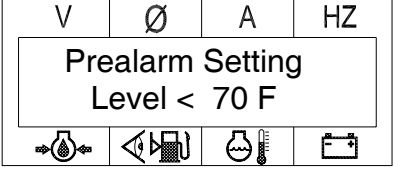
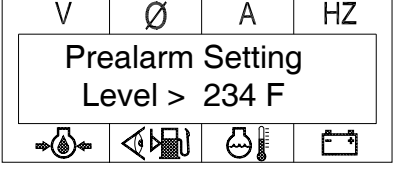
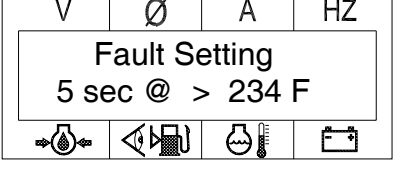
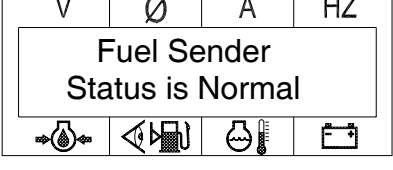
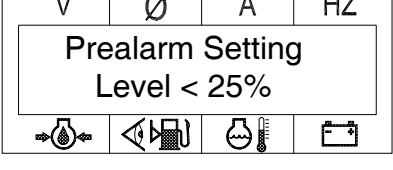
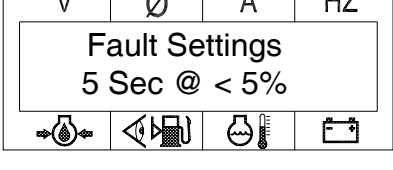
	<p>The display shows the value of the fault setting for low oil pressure. If the ECM detects that the engine oil pressure is less than 15 psi for longer than 15 seconds, the ECM will shut down the generator.</p>
	<p>The display shows this screen if the time to service timer has been reset to 250 hours.</p>
	<p>The display shows the value of the prealarm setting for low engine temperature. If the ECM detects that the engine temperature is less than 70°F, the engine temperature reading on the run screen will blink.</p>
	<p>The display shows the value of the prealarm setting for high engine temperature. If the ECM detects that the engine temperature is greater than 234°F (218°F on Isuzu engines), the engine temperature reading on the run screen will blink.</p>
	<p>The display shows the value of the fault setting for high engine temperature. If the ECM detects that the engine temperature is greater than 239°F (221°F on Isuzu engines) for longer than 5 seconds, the ECM will shut down the generator.</p>
	<p>The display shows the status of the fuel sender. If the fuel sender has failed, the time of the failure will be displayed. The time of the failure will be included in the display until the generator has been shut down and remains shutdown for a period of approximately two minutes.</p>
	<p>The display shows the value of the prealarm setting for low fuel level. If the ECM sees that the fuel level has dropped below 25%, the fuel level reading on the run screen will start to blink.</p>
	<p>The display shows the value of the alarm setting for low fuel level. If the ECM sees that the fuel level is less than 5% for longer than 5 seconds, the ECM will shut down the generator.</p>

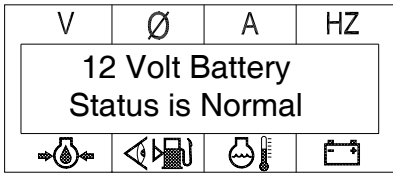
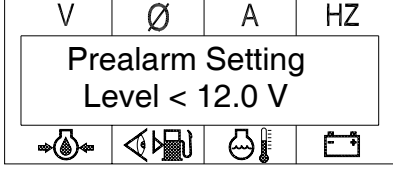
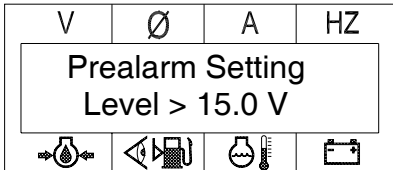
 <p>V Ø A HZ</p> <p>12 Volt Battery Status is Normal</p>	<p>The display shows the status of the battery. When the battery voltage is within its “normal” range, 12 –15V, the ECM displays the voltage value in 1/10V increments on the run screen.</p>
 <p>V Ø A HZ</p> <p>Prealarm Setting Level < 12.0 V</p>	<p>The display shows the battery low-voltage prealarm setting. When the ECM detects that battery voltage is less than 12V, the battery voltage reading on the run screen will blink.</p>
 <p>V Ø A HZ</p> <p>Prealarm Setting Level > 15.0 V</p>	<p>The display shows the battery high-voltage prealarm setting. When the ECM detects that battery voltage is greater than 15V, the battery voltage reading on the run screen will blink.</p>

G 85 (9305), G 125, G160 John Deere Engines with ECU

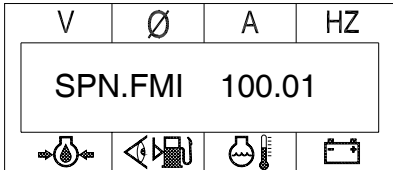
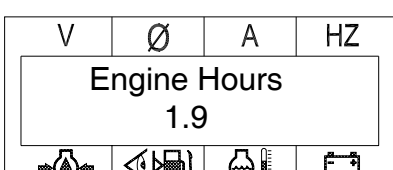
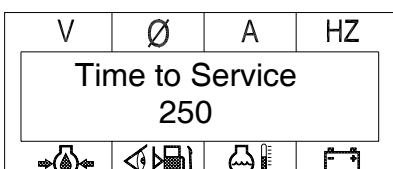
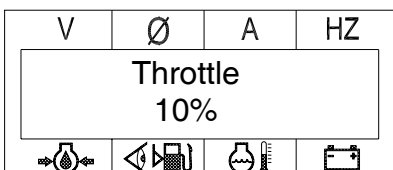
ECM Display	Description
 <p>V Ø A HZ</p> <p>SPN.FMI 100.01</p>	<p>John Deere engine diagnostic codes. SPN = Suspect Parameter Number FMI = Failure Mode Identifier. The ten most recent codes will be displayed from most current to least current. See the John Deere Engine Manual for details.</p>
 <p>V Ø A HZ</p> <p>Engine Hours 1.9</p>	<p>The display shows total time, in 1/10 hour increments, that the engine has been run. New machines, or machines with new ECMs, will read “No Data” because the engine has not been run for more than 1/10 of an hour.</p>
 <p>V Ø A HZ</p> <p>Time to Service 250</p>	<p>The display shows the amount of time left until service on the machine is required. To reset the timer to 250 hours, hold the Hours/Reset toggle switch in the up position until all the screens have been scrolled through twice.</p>
 <p>V Ø A HZ</p> <p>Throttle 10%</p>	<p>The display shows the amount the throttle is open at the current point in time.</p>

<p>The display shows the present load on the engine. For no load conditions (generator not powering any outside tools or equipment) the display will read 15%.</p>	<p>The display shows the present load on the engine. For no load conditions (generator not powering any outside tools or equipment) the display will read 15%.</p>
<p>The display shows the percentage of total engine torque being used.</p>	<p>The display shows the percentage of total engine torque being used.</p>
<p>The display shows, in °F, the temperature of the fuel.</p>	<p>The display shows, in °F, the temperature of the fuel.</p>
<p>The display shows, in psi, fuel pressure.</p>	<p>The display shows, in psi, fuel pressure.</p>
<p>The display shows, in gallons per hour (GPH), the rate at which fuel is being consumed.</p>	<p>The display shows, in gallons per hour (GPH), the rate at which fuel is being consumed.</p>
<p>The display shows, in °F, the temperature of the engine intake manifold.</p>	<p>The display shows, in °F, the temperature of the engine intake manifold.</p>

4.6 Voltage Display Errors

See Graphic: *wc_gr003308*

- Single-Phase Display Mode

When operating in the single-phase 120/240V position, line-to-line voltage will be displayed under P2 (240V). Line-to-neutral voltage (120V) will be displayed under P1 and P3. This is the normal single-phase display mode.

- Three-Phase Display Mode

When operating in either three-phase position (208/120V or 480/277V), the line-to-line voltage will be displayed under P1, P2 and P3 of the ECM. For example, in the 480/277V position, with the control panel rheostat adjusted correctly, voltage values will read 480V on all three phases: P1=480, P2=480, and P3=480. In the 208/120V position, voltage values will read 208V on all three phases: P1=208, P2=208, and P3=208.

- If leg 2 (L2) voltage drops below 50V, the ECM is programmed to switch to its single-phase mode and stay there until the operator corrects the condition. Two common causes for this condition are: 1) starting the generator with the connection lug door open and then closing it with the engine still running; 2) starting the generator in its single-phase position (120/240V) then switching it to a three-phase position (208/120V or 480/277V) without turning the generator off first. Both instances will cause the ECM to display a less than line-to-neutral voltage for P1 and P2, and full line-to-line voltage for P3. For example, in the 480/277V position P1 and P2 will read approximately 190V while P3 will read 480V. The voltage values displayed in this mode can lead one to conclude that the generator is not running correctly, when actually it is fine; the system just needs to be reset. To correct/reset the condition: stop the engine, make sure the lug door is closed, and then restart the engine. Allow the generator to cycle through the phases several times to develop the maximum voltage.

- When in the three-phase mode, if any one of the legs (L1, L2, or L3) drops out, two of the three phases will automatically also drop out. For example, if leg 1 drops out, there can be no L1–L2 (P1) voltage, nor can there be L3–L1 (P3) voltage. (The values displayed under P1 and P2 will be residual voltage for the legs themselves, not line-to-line voltage. Residual is approximately 36V.) The voltage displayed under P3 will be L2 line-to-neutral voltage. This condition is known as single-phasing. It is a sign there is a problem with the generator.

- Engine Hour Switch in Locked Position

Another possible display error can occur when starting the machine with the engine hour switch **(a)** in the down (locked) position. This position is normally used to lock the display onto a single leg and to prevent the display from scrolling through volt and amp values for all three legs.

On some generators, starting the engine with the switch in the down (locked) position will reverse the display for volts and amps. To correct the display, return the engine hour switch to its unlocked (scroll) position.

To ensure the correct voltage display, make sure:

- The connection lug door is closed and latched before starting the engine.
- The voltage selection switch is in its correct position prior to starting the engine.
- The engine hour switch is in its unlocked (center) position.

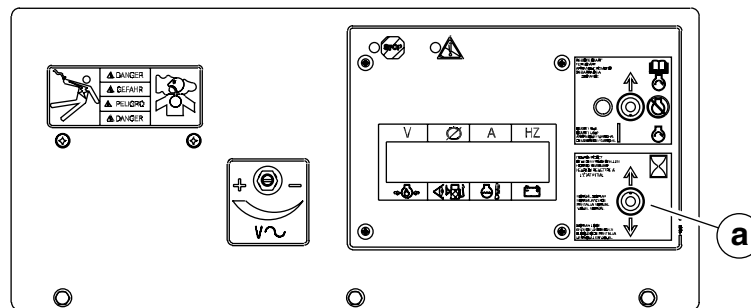

wc_gr003308

4.7 ECM Automatic Engine Shutdown Conditions

The engine protection system includes six automatic shutdown conditions: low oil pressure, high coolant temperature, engine underspeed/overspeed, engine overcrank, low fuel. The ECM will also shut down the engine if an over current condition exists.

When the ECM has shut down the unit due to one of the faults, the ECM will display the fault and other pertinent information to aid in diagnosing the problem. **RECORD ALL THE INFORMATION LISTED** on the display, then refer to the following sections to diagnose and rectify the problem.

When the engine has shut down due to something outside the control of the ECM, the ECM will display “ENGINE STOPPED”.

Fault	Prealarm setpoint	Shutdown setpoint
Low oil pressure	20 psi	15 psi
High coolant temperature	100°C (211°F) Isuzu 112°C (234°F) John Deere	105°C (221°F) Isuzu 115°C (239°F) John Deere
Underspeed	n/a	55 Hz (1650 rpm)
Overspeed	n/a	67 Hz (2010 rpm)
Overcrank	n/a	After third attempt
Fuel level	25%	5%

4.8 ECM Circuit Boards

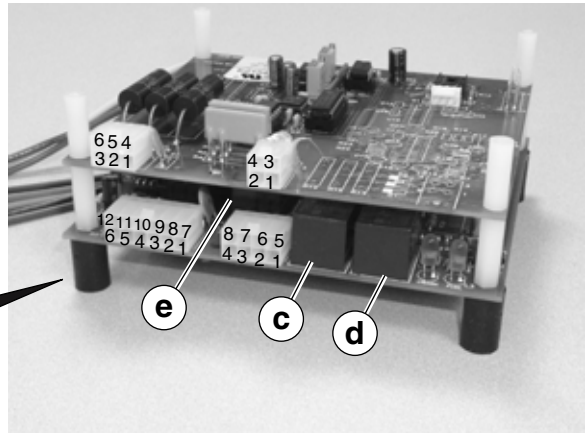
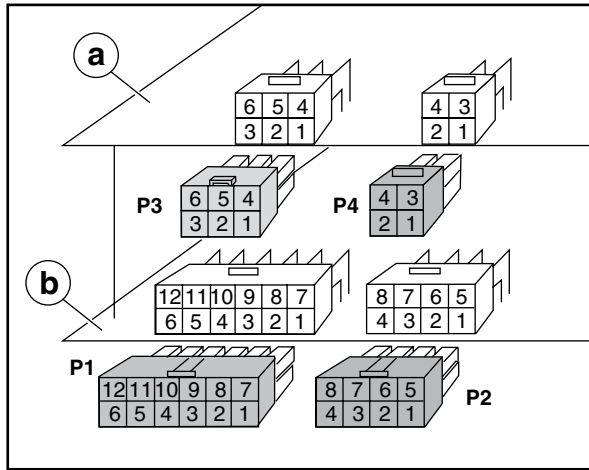

wc_gr002924

Note: Your machine's ECM board may differ slightly from the one pictured.

Ref.	Description
a	AC board
b	Engine board
c	Crank relay
d	Fuel relay
e	Preheat relay
P1	Power and engine sensing
P2	Power to crank, fuel and fault prealarm closures
P3	AC Amps connection to current transformers
P4	AC Volts connection to voltage selector switch

4.9 Control Wiring Numbering & Colors

See Graphic: *wc_gr002924*

Generator and control wires are marked and color coded to assist in tracing line connections and troubleshooting. The charts below list wire labels and colors followed by a description of their use.

G 25 Control Module		
Plug 1: Engine Sender Inputs (12-pin connector)		
1	Black	Magnetic pickup
2	Clear, shield	Magnetic pickup
3	White/Blue	Oil pressure sender
5	Yellow	Water temperature sender
7	Red	Run/Off/Auto switch, +12V (positive)
8	Black	12VDC supply, - ground (negative)
10	Orange	Remote start contacts
11	Red	Emergency stop pushbutton
12	White-Violet	Fuel level sender
Plug 2: Engine Start Inputs/Outputs (8-pin connector)		
1	Yellow-Red	Out; 12VDC to starter relay
2	Violet	Out; 12VDC to E-stop switch
5	Red	In; 12VDC from B+ through 10A fuse
7	Red	In; 12VDC from B+
8	Green	Out; 12VDC to glow plug relay
Plug 3: Current Transformer Inputs (6-pin connector)		
1	White	Ammeter line input CT common
2	Brown	Ammeter line input CT1
4	Orange	Ammeter line input CT3
5	Yellow	Ammeter line input CT2
Plug 4: Line Voltage Inputs (4-pin connector)		
2	Brown	Voltage line input L1 at volt selector #3

3	Orange	Voltage line input L3 at volt selector #28
4	Yellow	Voltage line input L2 at volt selector #20

G 50/70/85 Control Module		
Plug 1: Engine Sender Inputs (12-pin connector)		
1	Black	Magnetic pickup
2	Clear, shield	Magnetic pickup
3	White-Black	Oil pressure sender
5	Yellow	Water temperature sender
7	Red	Run/Off/Auto switch, +12V (positive)
8	Black	12VDC supply, - ground (negative)
10	Orange	Remote start contacts
11	Green	Emergency stop pushbutton
12	White-Violet	Fuel level sender
Plug 2: Engine Start Input/Outputs (8-pin connector)		
1	Yellow	Out; 12VDC to starter relay
2	Violet	Out; 12VDC to E-stop switch
5	Red	In; 12VDC from starter relay (B+) through 10A fuse
7	Red	In; 12VDC from starter relay (B+)
8	Green	Out; 12VDC to air intake heater relay
Plug 3: Current Transformer Inputs (6-pin connector)		
1	White	Ammeter line input CT common
2	Brown	Ammeter line input CT1
4	Orange	Ammeter line input CT3
5	Yellow	Ammeter line input CT2
Plug 4: Line Voltage Inputs (4-pin connector)		
2	Brown	Voltage line input L1 at volt selector #3
3	Orange	Voltage line input L3 at volt selector #28
4	Yellow	Voltage line input L2 at volt selector #20

G 125/160 Control Module		
Plug 1: Engine Sender Inputs (12-pin connector)		
3	White-Blue	Crank delay, preheat
5	-	-
7	Red	Run/Off/Auto switch, +12V (positive)
8	Black	12VDC supply, - ground (negative)
9	Orange	Remote start contacts
10	Gray	Emergency stop pushbutton
12	White-Violet	Fuel level sender
Plug 2: Engine Start Input/Outputs (8-pin connector)		
1	Yellow	Out; 12VDC to starter relay
2	Violet	Out; 12VDC to E-stop switch
5	Red	In; 12VDC from starter relay (B+) through 10A fuse
Plug 3: Current Transformer Inputs (6-pin connector)		
1	White	Ammeter line input CT common
2	Brown	Ammeter line input CT1
4	Orange	Ammeter line input CT3
5	Yellow	Ammeter line input CT2
Plug 4: Line Voltage Inputs (4-pin connector)		
2	Brown	Voltage line input L1 at volt selector #3
3	Orange	Voltage line input L3 at volt selector #28
4	Yellow	Voltage line input L2 at volt selector #20

4.10 Removing and Installing the ECM

See Graphic: *wc_gr003316*

Removal:

- 4.10.1 Remove the nut securing the hour meter switch **(a)** and the nut securing the start switch **(b)** to the panel.
 - 4.10.2 Disconnect the four harness plugs **(e)**.
 - 4.10.3 Remove the three red wires **(d)** from the start switch. Remove the start switch, the hour meter switch, and the ECM from the panel.
- Note:** Replacement ECMs include start and hour meter switches.
- 4.10.4 Remove the screws **(c)** securing the ECM to the panel.

Installation:

- 4.10.5 Secure the ECM to the panel with screws **(c)**.
- 4.10.6 Secure the hour meter **(a)** and the start switch **(b)** to the control panel.
- 4.10.7 Reconnect the four harness plugs **(e)**.
- 4.10.8 Reinstall the three red wires **(d)** to the start switch.

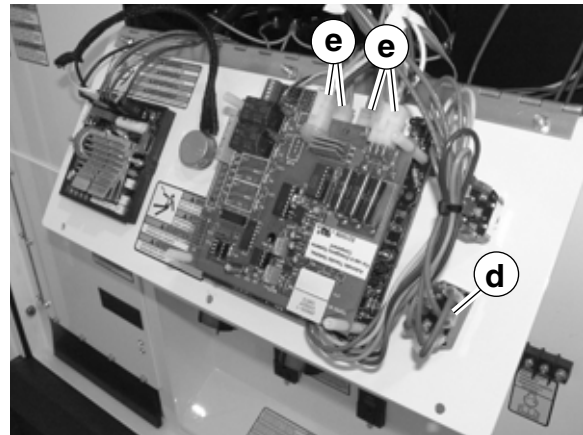
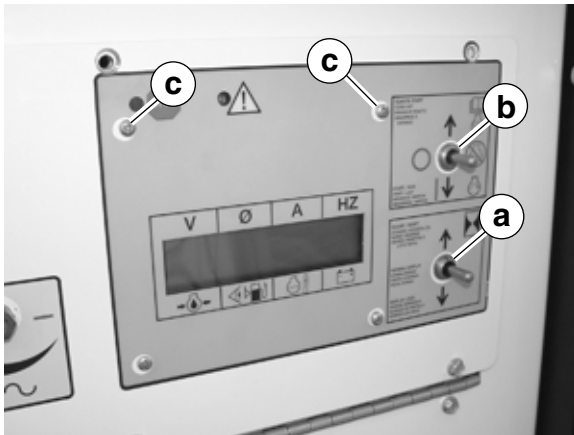

wc_gr003316

5. ECM/Sensor Troubleshooting

5.1 Checking Power to the ECM

Prerequisites ■ Fully-charged (12+ Volts) battery

Procedure Follow the procedure below to check the fuses.

1. Locate the 10A and 30A fuses near the John Deere Engine Control Unit (ECU).

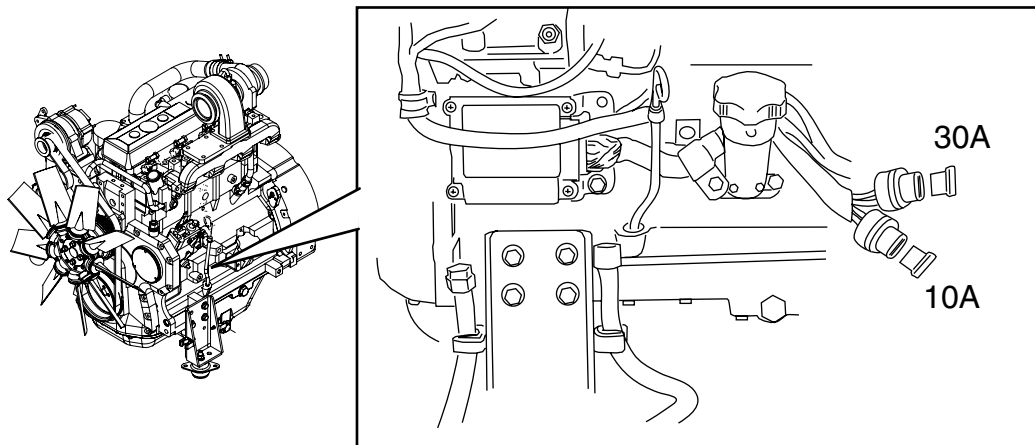

wc_gr003735

2. Check the condition of the 10A fuse.

Is the fuse OK?

Yes ____	No ____
Continue	Replace the fuse with one of the same size and rating.

3. Check the condition of the 30A fuse.

Is the fuse OK?

Yes ____	No ____
Continue	Replace the fuse with one of the same size and rating.

4. Check the condition of the ECM 10A fuse.

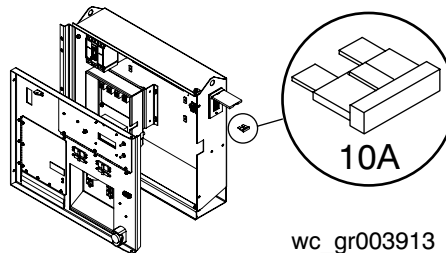

wc_gr003913

Is the fuse OK?

Yes ____	No ____
The fuses are OK.	Replace the fuse with one of the same size and rating.

This procedure continues on the next page.

Continued from the previous page.

5. Check the voltage between red wire #51 at B+ terminal strip and ground.

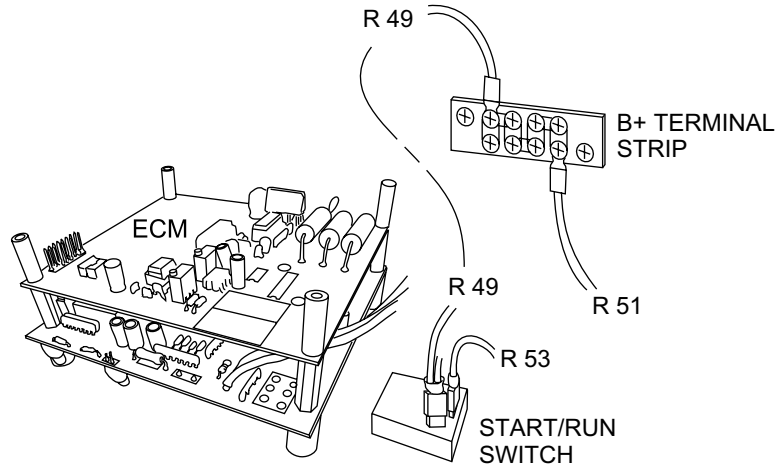

Is at least 9.8V measured?

Yes _____	No _____	Your reading
Continue	Repair red wire #51.	

6. Check voltage between red wire #49 at START/RUN switch and ground.

Is at least 9.8V measured?

Yes _____	No _____	Your reading
Continue	Repair red wire #49	

7. Place the START/RUN switch in the ON position.

8. Check the voltage between red wire #53 at START/RUN switch and ground.

Is at least 9.8V measured?

Yes _____	No _____	Your reading
Continue	Replace the START/RUN switch.	

This procedure continues on the next page.

Continued from the previous page.

- Check the voltage between ECM pin 7 plug 1 (red wire #53) and pin 8 plug 1 (black wire #59).

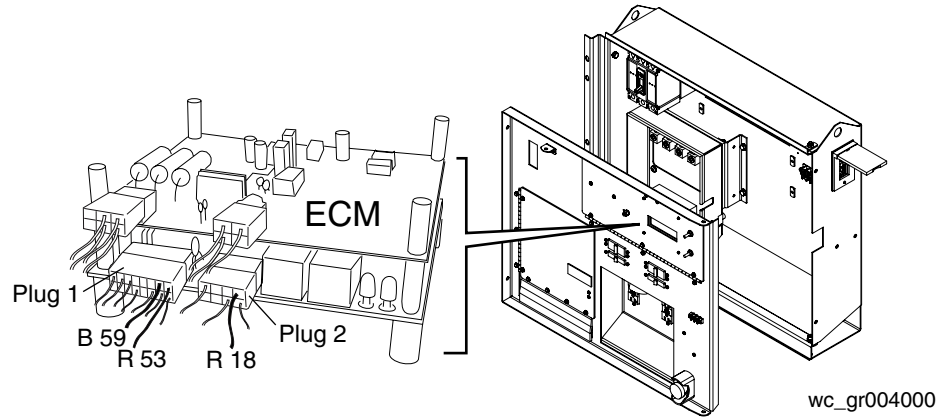

Is at least 9.8V measured?

Yes _____	No _____	Your reading
Continue	Repair red wire #53.	

- Check the voltage between ECM pin 5 plug 2 (red wire #18) and ground.

Is at least 9.8V measured?

Yes _____	No _____	Your reading
Power to the ECM is OK.	Check continuity of red wire #18 between ECM and fuse box. Also check red wire #48 between fuse box and B+ terminal strip. Repair the wiring as needed.	

Incoming power to the ECM has now been checked,

5.2 Checking Outgoing Power From the ECM

- Prerequisites**
- Fully-charged (12+ Volts) battery
 - At least 9.8VDC incoing power to ECM on red wires #18 and #53

Procedure Follow the procedure below to check the outgoing power from the ECM.

1. Open the control panel and locate the ECM..

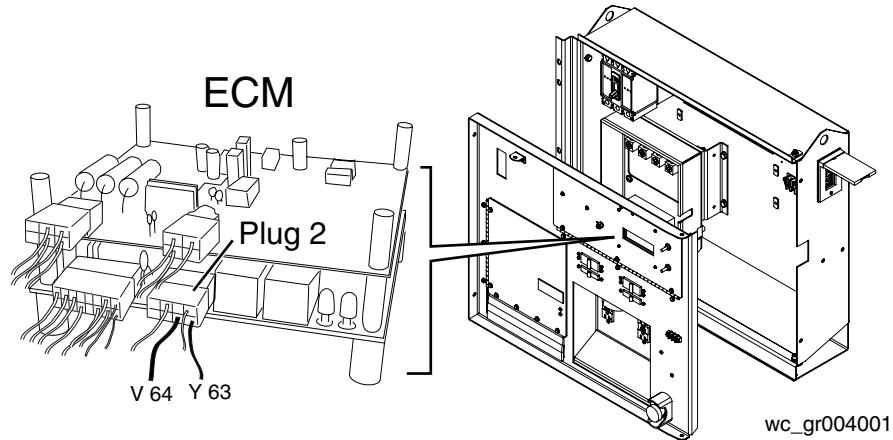

2. Place the START/RUN switch in the ON position.
3. Check the voltage between pin 1 plug 2 (yellow wire #63) and ground.

Is at least 9.8V measured?

Yes _____	No _____	Your reading
Coninue	The ECM has failed. Call Wacker Service.	

4. Check the voltage between pin 2 plug 2 (violet wire #64) and ground.

Is at least 9.8V measured?

Yes _____	No _____	Your reading
Outgoing power from the ECM is OK.	The ECM has failed. Call Wacker Service.	

Outgoing power from the ECM has now been checked.

5.3 Checking Temperature Sender

Prerequisites ■ Fully-charged battery

Procedure Follow the procedure below to check the ECM and the temperature sender.

1. Open the large hinged panel and locate the temperature sender.

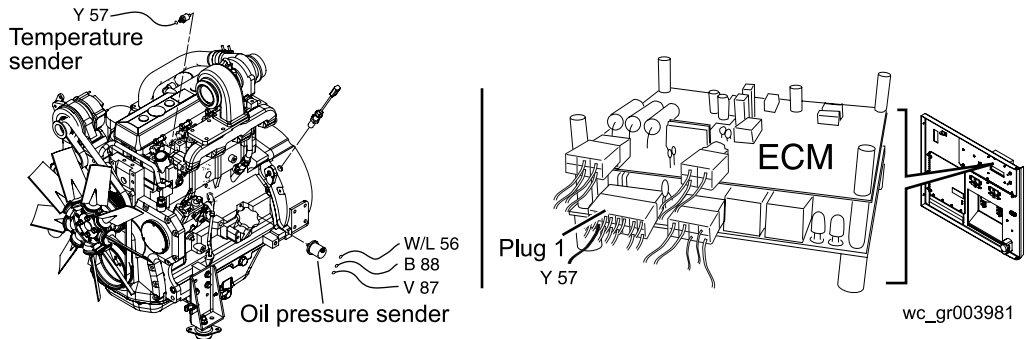

2. Disconnect yellow wire #57 from the temperature sender.
3. Place the START/RUN switch in the ON position.
4. Measure the voltage between yellow wire #57 and ground.

Is at least 4.8 VDC measured?

Yes _____	No _____	Your reading
Go to step 8.	Continue	

5. Open the control panel and locate the ECM.
6. Place the START/RUN switch in the ON position.
7. Measure the voltage between ECM plug 1 pin 5 and ground.

Is at least 4.8 VDC measured?

Yes _____	No _____	Your reading
Repair yellow wire #57; then continue.	The ECM has failed. Call Wacker Service.	

8. Measure the resistance between the sender and ground.
9. Find the resistance measured in the chart below.

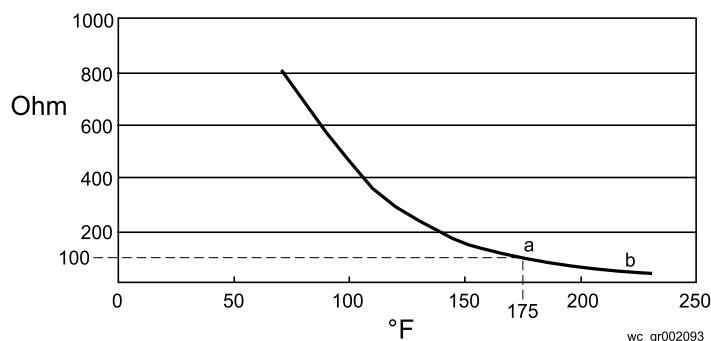

Does the resistance measured reflect the engine temperature?

Yes _____	No _____
Continue	The temperature sender has failed; replace it.

This procedure continues on the next page.

Continued from previous page.

10. Reconnect yellow wire #57 to the temperature sender.
11. Start the engine.
12. Measure the voltage between the sender and ground.
13. Find the voltage measured in the chart below.

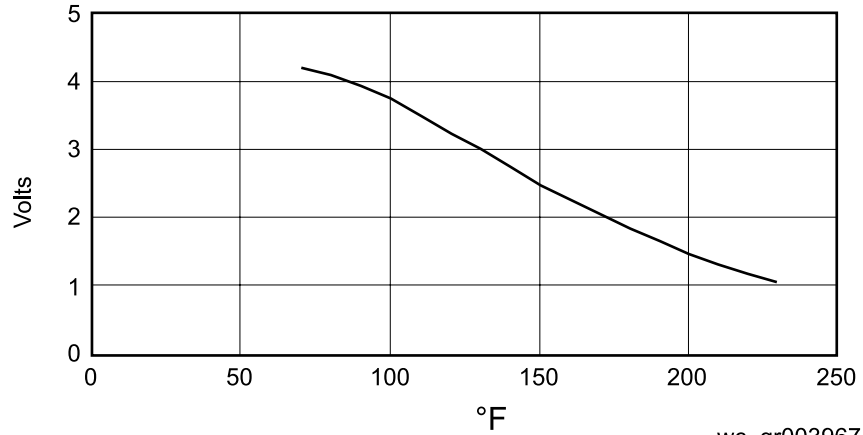

wc_gr003967

Does the voltage measured reflect the engine temperature?

Yes _____

No _____

The temperature sender is OK; the ECM may have failed. Call Wacker Service.

The temperature sender has failed; replace it.

The temperature sender has now been checked.

5.4 Fuel Sender Failure and Low Fuel Fault

Prerequisites ■ Fuel in fuel tank

Procedure Follow the procedure below to check the ECM and fuel sender.

1. Open the large hinged panel and locate the fuel sender.

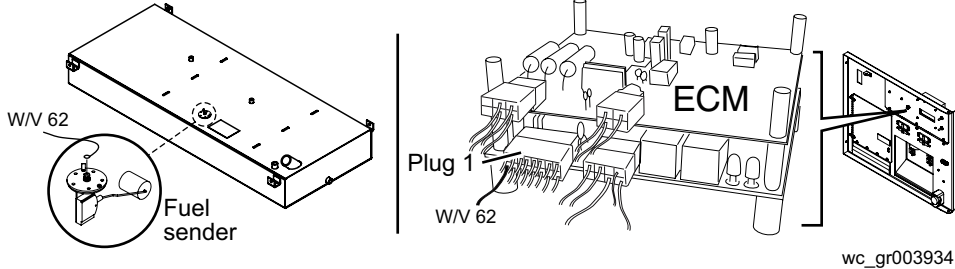

2. Disconnect white/violet (W/V) wire #62 from the fuel sender.
3. Place the START/RUN switch in the ON position.
4. Measure the voltage between W/V wire #62 and ground.

Is at least 4.8 VDC measured?

Yes _____	No _____	Your reading
Go to step 8.	Continue	

5. Open the control panel and locate the ECM.
6. Place the START/RUN switch in the ON position.
7. Measure the voltage between ECM plug 1 pin 12 (W/V wire #62) and ground.

Is at least 4.8 VDC measured?

Yes _____	No _____	Your reading
Repair W/V wire #62; then continue.	The ECM has failed. Call Wacker Service.	

8. Measure the resistance between the fuel sender and ground.
9. Find the resistance measured in the chart below.

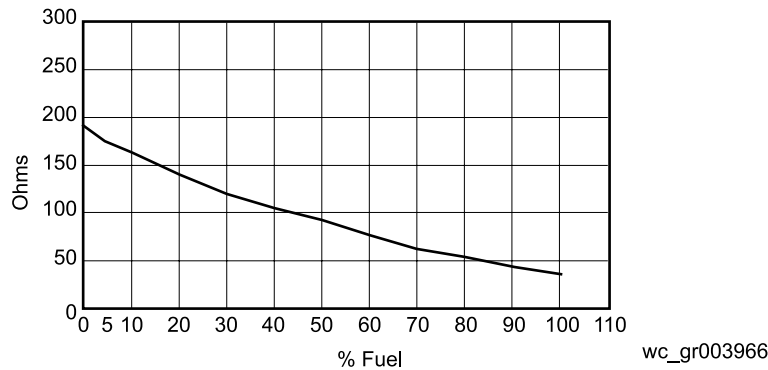

Does the resistance measured reflect the actual fuel level in the tank?

Yes _____	No _____
The fuel sender is OK; the ECM has failed. Call Wacker Service.	The fuel sender has failed; replace it.

10. Reconnect W/V wire #62.
- The ECM and fuel sender have now been checked.

5.5 Calibrating ECM Voltage Display

Prerequisites ■ Functioning generator

Procedure Follow the procedure below to calibrate the ECM voltage display.

1. Open the large hinged panel. Remove the “key” (latch) from the lug door and place it in the slot of the lug door switch. **NOTICE:** Never place anything but the key into the slot of the lug door switch.

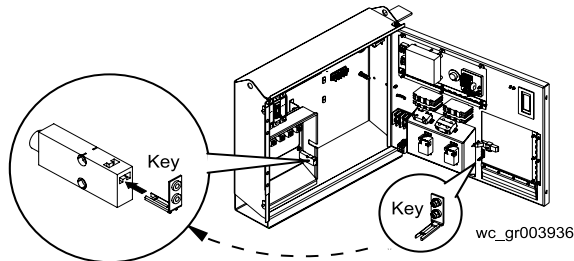

2. Close the large hinged panel.
3. Place the START/RUN switch in the ON position so that the engine starts.



WARNING! Electric shock hazard. High voltage exists at the lugs when the engine is running. Electric shock can cause injury or death. Do not touch the lugs.

4. Open the lug door.
5. With a multimeter, measure the AC voltage between lug 1 and lug 2.

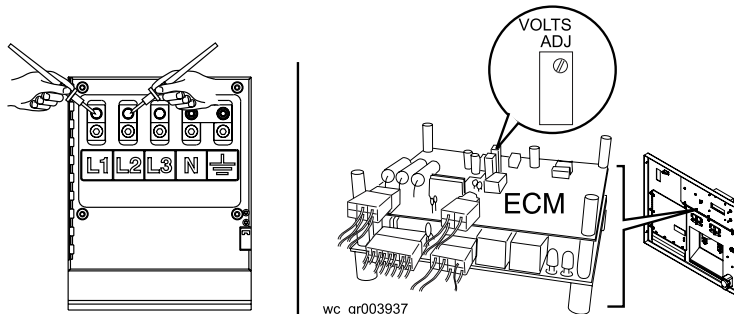

6. Compare the reading on the multimeter with that on the ECM.
Are the readings within 2 Volts?

Yes _____	No _____	Your reading
No adjustment is necessary.	Continue	

7. Open the control panel and locate the VOLTS ADJ pot on the ECM.



WARNING! Electric shock hazard. High voltage exists at the cooling fins of the AVR when the engine is running. Electric shock can cause injury or death. Do not touch the AVR.

8. Adjust the VOLTS ADJ pot until the ECM reads the same as the voltage measured at the lugs.
9. Re-install the key to the door switch and close the control panel.
The ECM voltage has now been calibrated.

5.6 Calibrating ECM AC Amperage Display

- Prerequisites**
- Functioning generator
 - Ammeter
 - 25A or greater load

Procedure Follow the procedure below to calibrate the ECM amperage display.

1. Attach a 25A or greater load to the lugs.
2. Place the START/RUN switch in the ON position so that the engine starts.
3. Close the main circuit breaker.
4. Attach a clamp-style ammeter to one of the lines connected to the lugs.
5. Observe the ECM display as it cycles through the amperage values for each leg. Place the hour meter switch into the down position when the ECM displays an amperage value.

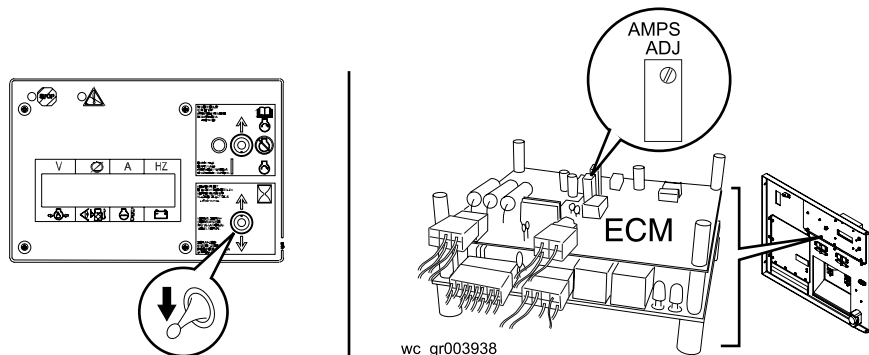

6. Compare the Amp reading on the ammeter with that on the ECM display.

Are the readings within 0.5 Amps?

Yes _____	No _____	Your reading
No adjustment is necessary.	Continue	

7. Open the control panel and locate the AMPS ADJ pot.



WARNING! Electric shock hazard. High voltage exists at the cooling fins of the Automatic Voltage Regulator (AVR) when the engine is running. Electric shock can cause injury or death. Do not touch the AVR.

8. Adjust the AMPS ADJ pot until the ECM reads the same as the amperage measured by the ammeter.

9. Close the control panel.

The ECM amperage display has now been calibrated.

5.7 Calibrating ECM AC Frequency Display

Prerequisites

- Functioning generator

Procedure

Follow the procedure below to calibrate the ECM AC frequency display.

Note: Recalibrate only if your unit is off by more than 5Hz.

1. Start the generator. Using a tachometer or vibrotach, adjust the engine speed to 1800 rpm or 60Hz.
2. Open the control panel to gain access to the ECM. Monitor the ECM display panel as adjustments are made.



WARNING! Electric shock hazard. High voltage exists at the cooling fins of the Automatic Voltage Regulator (AVR) when the engine is running. Electric shock can cause injury or death. Do not touch the AVR.

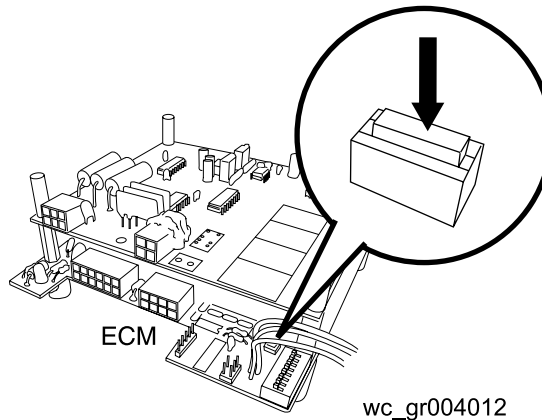

3. Locate the AC frequency push button. Hold the AC frequency push button in until the ECM display reads 60Hz.
4. Set the engine no-load speed to 1850 rpm.
The ECM AC frequency has now been calibrated.

5.8 Calibrating ECM DC Display

Prerequisites ■ Functioning generator

Procedure Follow the procedure below to calibrate the ECM DC voltage (12V battery) display.

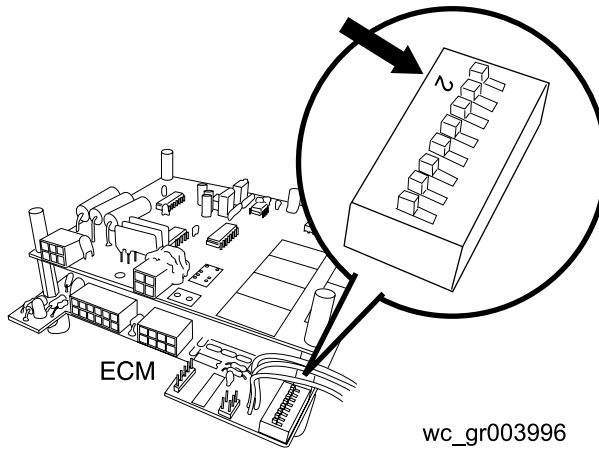

1. Measure the voltage across the machine's 12V battery using a multimeter. **Note:** *This procedure works best when the battery voltage measures 12.6VDC.*
 2. Place the start switch in the REMOTE START position.
 3. Open the control panel to gain access to the ECM.
 4. Slide the number 2, Dual-In-line Package (DIP) switch to the ON position and then back to the OFF position. This resets the DC voltage display.
- The ECM DC voltage display is now calibrated.

5.9 ECM Plugs and Pins

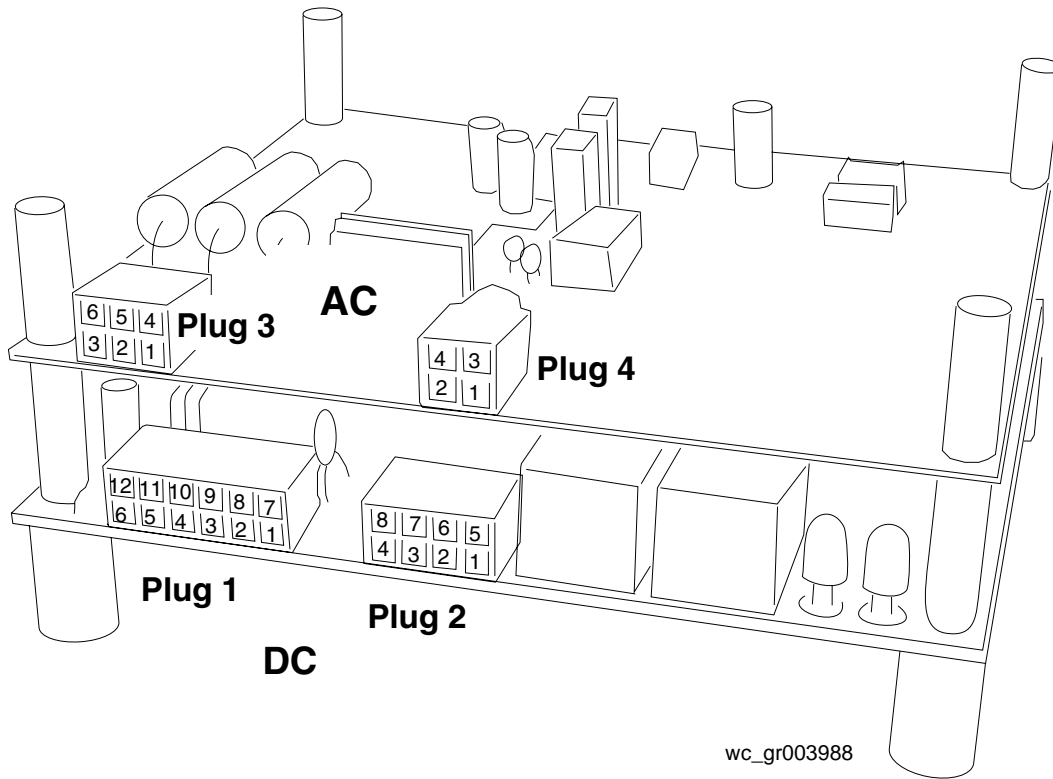

wc_gr003988

ECM Plug 1 Wires			ECM Plug 2 Wires		
Pin	Wire	Description	Pin	Wire	Description
10	Gr/61	Emergency stop	5	R/18	Battery + (for relays)
3	W/L/56	Oil pressure sender	1	Y/63	Crank (12V output)
9	Or/60	Remote start	2	V/64	Run/Fuel (12V output)
12	W/V/62	Fuel level	3	73	Remote annunciator (NA)
8	B/59	Battery -	4	75	Remote annunciator (NA)
7	R/53	Battery + (for ECM board)	-	-	---

NOTES

6. John Deere Engine's With ECU

6.1 John Deere Engine's With ECU Background

The Tier II John Deere engines with electronic control systems are used on Wacker generator models G 85, G 125, and G 160. The electronic control system consists of:

- Engine Control Unit (ECU); the computer which controls fuel, and the ignition system.
- The following sensors: oil pressure, coolant temperature, fuel temperature, manifold air temperature, crank position and speed.
- Fuel pump control solenoid.
- Manifold air heater.

The electronic control system serves as a governor by controlling the fuel to the engine. It does so by controlling the engine's injection pump control valve through a proportional solenoid. In doing so, fuel is delivered according to engine conditions, in precise amounts, and at the precise time in relation to piston position.

The ECU communicates with the Engine Control Module (ECM) mounted to the generator's control panel through a Controller Area Network (CAN). The wiring between the controllers forms a bus (physical electrical interface where many devices share the same electrical connections). Diagnostic tools available from John Deere can plug into the CAN bus to assist in troubleshooting the operation of the engine. The ECM controls the engine up through engine start (cranking). Once started, the ECU controls the running of the engine.

The ECU has diagnostic abilities and shares engine diagnostic information through codes which are displayed on the ECM display screen. These diagnostic codes are referred to as "SPN/FMI" codes: Suspect Parameter Number (SPN) and Failure Mode Identifier (FMI). SPN/FMI codes are conveyed in a two-part code number. The SPN typically contains between two and four digits and is the first number of the code. The FMI contains one or two digits and is the second number of the code. For example, if the ECM displays "SPN/FMI 100.4", The SPN "100" indicates a condition with the engine oil. FMI "4" indicates that the engine oil pressure input voltage is lower than the sensor's specification—a condition associated with a disconnected oil pressure sensor. There are many such SPN/FMI codes. See the John Deere service manual for more information

6.2 Locations of Engine Electrical Components

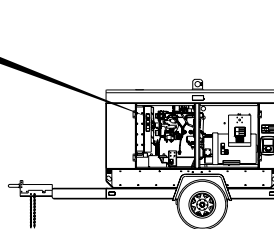
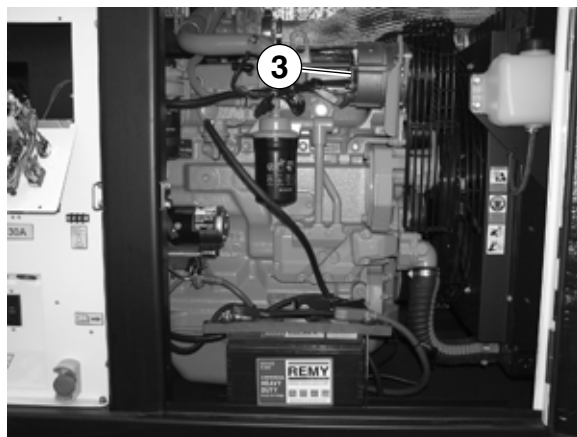
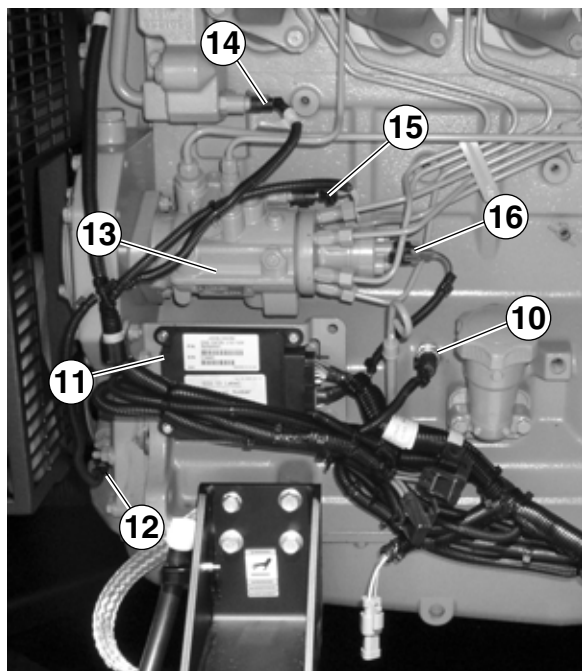
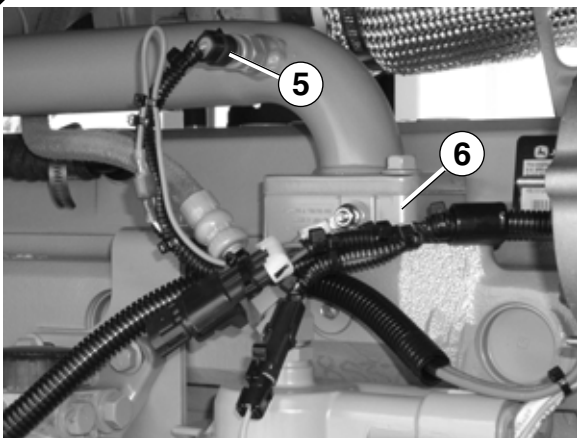
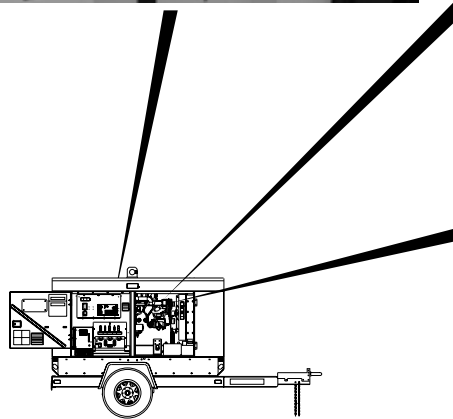
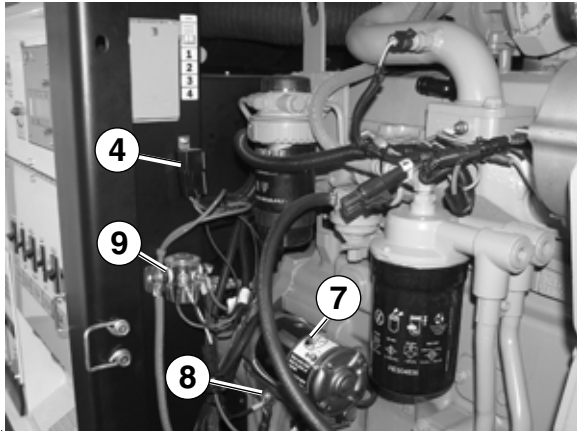
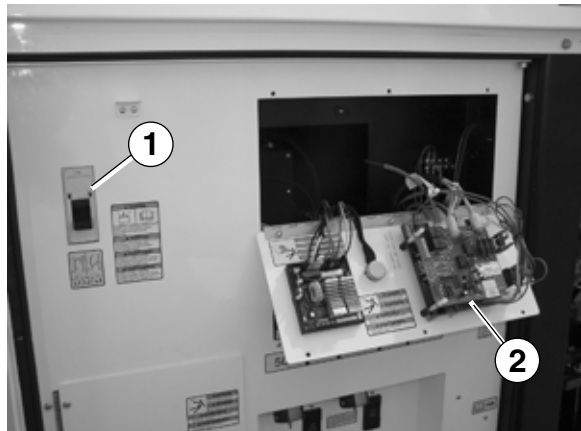

wc_gr003343

6.3 Engine Electrical Components

See Graphic: *wc_gr003343*

Ref.	Component	Ref.	Component
1	Main circuit breaker	9	Starter relay
2	Engine Control Module (ECM)	10	Oil pressure sensor
3	Alternator	11	Engine Control Unit (ECU)
4	Slave preheat relay	12	Crank position sensor
5	Manifold air temperature sensor	13	Fuel pump assembly
6	Manifold heater	14	Coolant temperature sensor
7	Starter motor	15	Fuel temperature sensor
8	Starter motor solenoid	16	Fuel pump control solenoid

Engine Starting Troubleshooting—John Deere with ECU

7. Engine Starting Troubleshooting—*John Deere with ECU*

7.1 Checking the Fuses

Prerequisites ■ Battery voltage measuring 11–13VDC

Procedure Follow the procedure below to check the fuses.

1. Locate the 10A and 30A fuses near the John Deere Engine Control Unit (ECU).

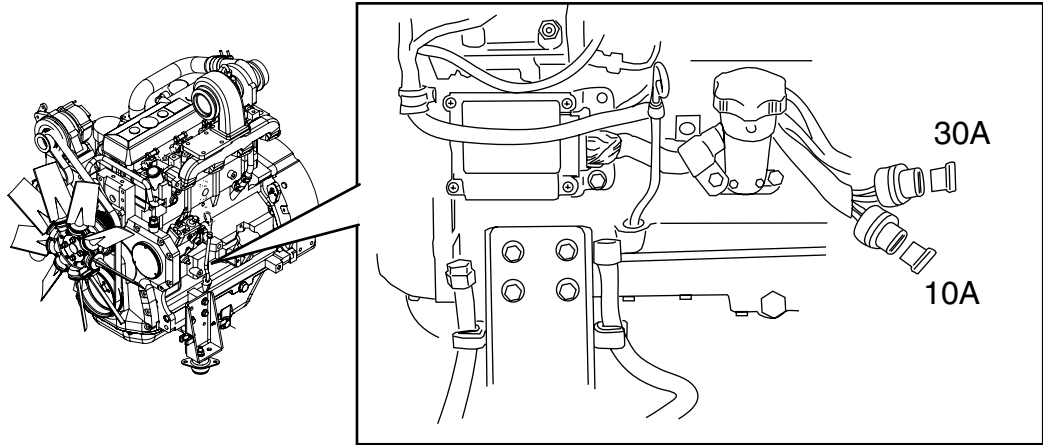

wc_gr003735

2. Check the condition of the 10A fuse.

Is the fuse OK?

Yes _____	No _____
Continue	Replace the fuse with one of the same size and rating.

3. Check the condition of the 30A fuse.

Is the fuse OK?

Yes _____	No _____
Continue	Replace the fuse with one of the same size and rating.

4. Check the condition of the ECM 10A fuse.

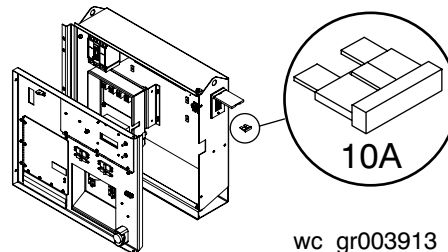

wc_gr003913

Is the fuse OK?

Yes _____	No _____
The fuses are OK.	Replace the fuse with one of the same size and rating.

The fuses have now been checked. Continue with *Checking the ECM*.

Engine Starting Troubleshooting—John Deere with ECU

7.2 Checking the Engine Control Module (ECM)

Prerequisites ■ Generator shut down

Procedure Follow the procedure below to check the ECM.

1. Open the control panel and locate the ECM.

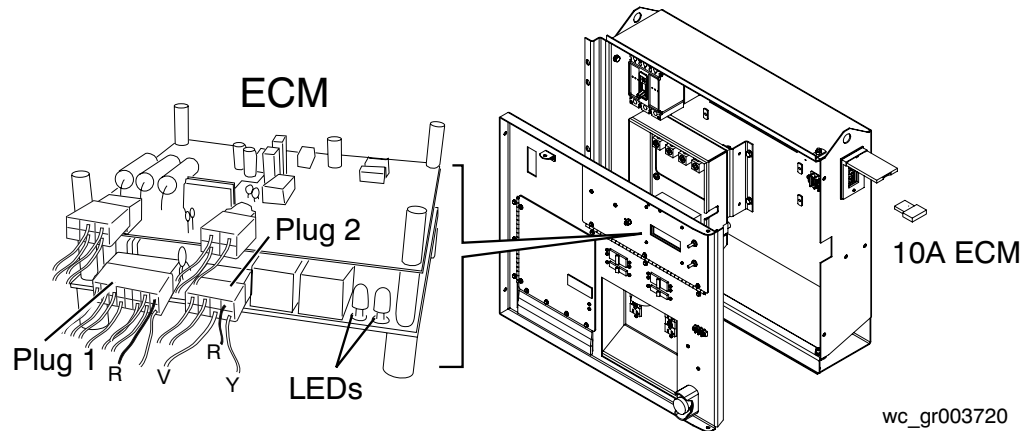

2. Place the START/RUN switch in the ON position.

Does the ECM boot up and do the "FUEL" & "CRANK" LEDs illuminate?

Yes _____	No _____
Go to step 6.	Continue

3. Check connections of battery cables. Also check battery voltage.

Is the battery voltage $12 \pm 2V$?

Yes _____	No _____	Your reading
Continue	Charge the battery.	

4. Locate Plug 1. Check the voltage between red wire #53 of the plug and ground.

Is at least 9.8V measured?

Yes _____	No _____	Your reading
Continue	Repair or replace wire #53.	

5. Locate Plug 2. Check voltage between red wire #18 and ground during cranking.

Is at least 9.8V measured?

Yes _____	No _____	Your reading
Continue	Repair or replace wire #15.	

6. Locate Plug 2. Check the voltage between violet wire #64 and ground. Also check the voltage between yellow wire #63 and ground during cranking.

Is there at least 9.8VDC measured in each case?

Yes _____	Yes _____	Yes _____
The ECM is OK.	The ECM has failed. Call Wacker Service.	

The ECM has now been checked. Continue with *Checking the Emergency Stop Switch*.

Engine Starting Troubleshooting—John Deere with ECU

7.3 Checking the Emergency Stop Switch

- Prerequisites**
- Generator shut down
 - Battery voltage measuring 11–13VDC

Procedure Follow the procedure below to check the emergency stop switch.

1. Place the emergency stop switch in the de-activated (out) position.
2. Place the START/RUN switch in the ON position.
3. Check the connections of the wiring to the emergency stop switch. Make sure all connections are tight.
4. Check the voltage between violet wire #64 and ground at the switch.

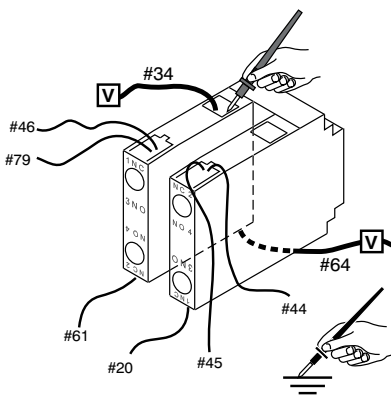
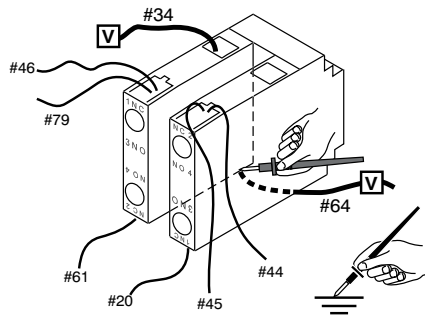

Old push/twist style

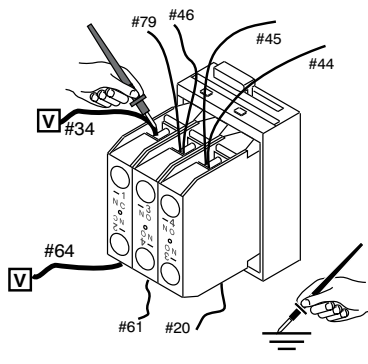
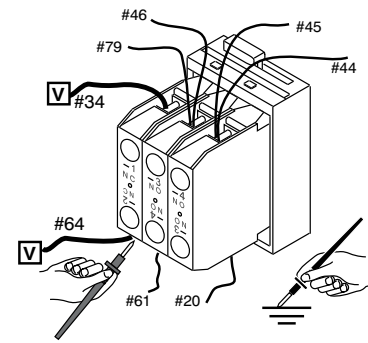

New push/pull style

wc_gr003685

Is at least 9.8 VDC measured?

Yes _____	No _____	Your reading
Continue	The emergency stop switch has failed; replace it.	

5. Check the voltage between violet wire #34 and ground at the switch.

Is at least 9.8VDC measured?

Yes _____	No _____	Your reading
The emergency stop switch is not the problem.	The emergency stop switch has failed; replace it.	

The emergency stop switch has now been checked. Continue with *Checking the Starter Relay*.

Engine Starting Troubleshooting—John Deere with ECU

7.4 Checking the Starter Relay

Prerequisites ■ Battery voltage measuring 11–13VDC

Procedure Follow the procedure below to check the starter relay.

1. Locate the starter relay.

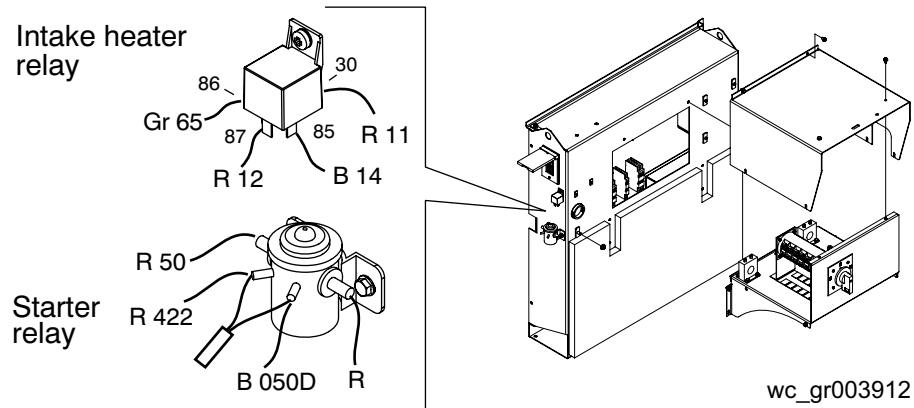

2. Check the voltage between the red wire running from the starter to the starter relay and ground.

Is at least 9.8VDC measured?

Yes _____	No _____	Your reading
Continue	Repair or replace the red wire.	

3. Place the START/RUN switch in the ON position.

4. Check the voltage between red wire #422 and ground during cranking.

Is at least 9.8VDC measured?

Yes _____	No _____	Your reading
Continue	Repair or replace wire #422.	

5. Check the connection to ground of black wire #050D and black wire 14.

Is there a path to ground?

Yes _____	No _____	Your reading
Continue	Repair or replace wire #050D or wire #14.	

6. Place the START/RUN switch in the ON position.

7. Check the voltage between the red wire running to the starter solenoid and ground

Is at least 9.8VDC measured?

Yes _____	No _____	Your reading
The starter relay is OK.	The starter relay has failed; replace it.	

The starter relay has now been checked. Continue with Checking the Starter Solenoid.

Engine Starting Troubleshooting—John Deere with ECU

7.5 Checking the Starter Solenoid

Prerequisites ■ Battery voltage measuring 11–13VDC

Procedure Follow the procedure below to check the starter solenoid.

1. Locate the starter and the starter solenoid.

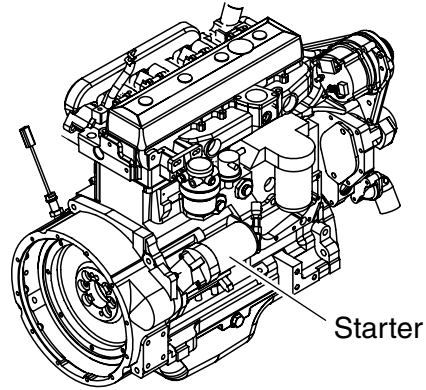

wc_gr003724

2. Check the connection of the large red wire.
3. Check the voltage between the large red wire and ground.

Is at least 9.8VDC measured?

Yes _____	No _____	Your reading
Continue	Repair or replace the large red wire.	

4. Place the START/RUN switch in the ON position. Check voltage between the small red wire and ground during the cranking cycle.

Is at least 9.8VDC measured?

Yes _____	No _____	Your reading
Continue	Repair or replace small red wire.	

5. If at least 9.8VDC is present at the starter and at the starter solenoid, the engine should crank. If the engine does not crank, the starter motor has failed. Replace the starter motor.

The starter solenoid has now been checked. Continue with *Checking the Intake Heater Relay*.

Engine Starting Troubleshooting—John Deere with ECU

7.6 Checking the Intake Heater Relay

Prerequisites ■ Battery voltage measuring 11–13VDC

Procedure Follow the procedure below to check the intake heater relay.

1. Locate the intake heater relay.

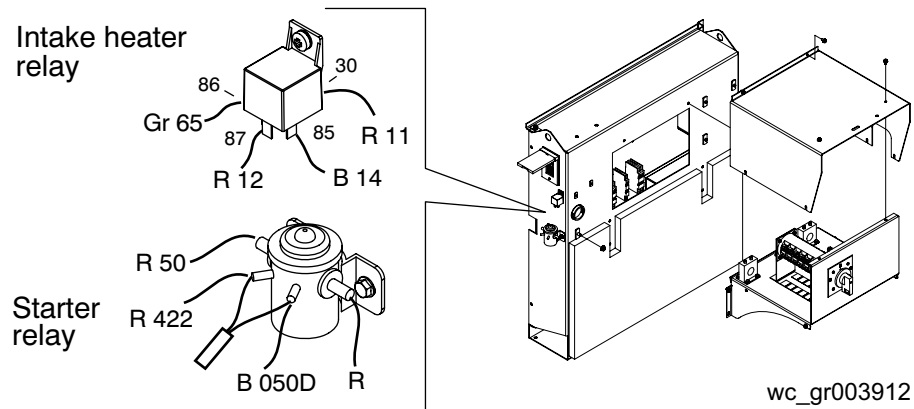

2. Check the voltage between terminal 30 (red wire #11) of the intake heater relay and ground.

Is at least 9.8VDC measured?

Yes _____	No _____	Your reading
Continue	Repair or replace red wire #11.	

3. Place the START/RUN switch in the ON position.

4. Check the voltage between terminal 86 (grey wire #65) and ground during cranking.

Is at least 9.8VDC measured?

Yes _____	No _____	Your reading
Continue	Repair or replace grey wire #65.	

5. Check the connection to ground of black wire #14 at terminal 85.

Is there a path to ground?

Yes _____	No _____	Your reading
Continue	Repair or replace wire #14.	

6. Place the START/RUN switch in the ON position.

7. Check the voltage between terminal 87 (red wire #12) and ground

Is at least 9.8VDC measured?

Yes _____	No _____	Your reading
The intake heater relay is OK.	The intake heater relay has failed; replace it.	

The intake heater relay has now been checked.

8. Output Voltage Troubleshooting

8.1 Checking the Emergency Stop Switch

Prerequisites ■ Generator shut down

Procedure Follow the procedure below to check the emergency stop switch.

1. Open the large hinged panel. Remove the "key" (latch) from the lug door and place it in the slot of the lug door switch. **NOTICE:** Never place anything but the key into the slot of the lug door switch.

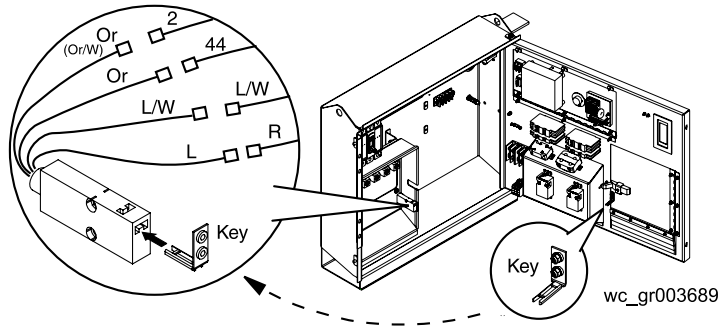

2. Place the emergency stop switch in the de-activated (out) position.
3. Check the connections of the wiring to the emergency stop switch. Make sure all connections are tight.
4. Check continuity across red wire #20 and yellow wire #45 at the switch.

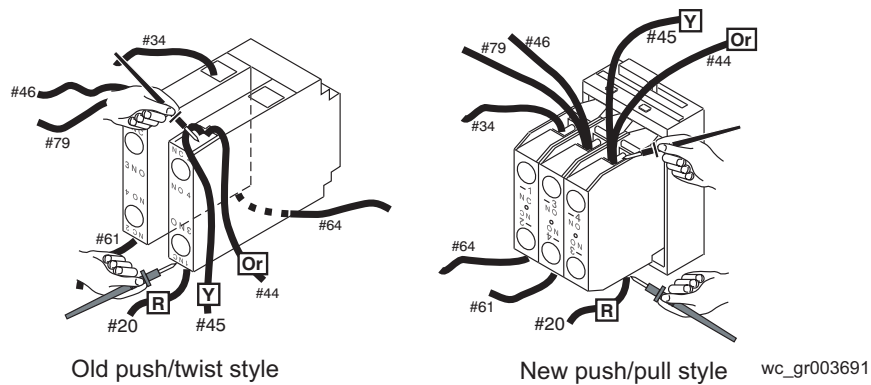

Is there continuity?

Yes _____	No _____
The emergency stop switch has failed; replace it.	Continue

5. Place the emergency stop switch in the activated (in) position.
6. Check continuity across red wire #20 and yellow wire #45 at the switch.

Is there continuity?

Yes _____	No _____
The emergency stop switch is OK.	The emergency stop switch has failed; replace it

7. Re-install the key (latch) to the lug door.

The emergency stop switch has now been checked. Continue with *Checking the Lug Door Switch*.

8.2 Checking the Lug Door Switch Prerequisites

- Generator shut down

Procedure

Follow the procedure below to check the lug door switch.

- Open the large hinged panel. Remove the "key" (latch) from the lug door and place in the slot of the lug door switch. **NOTICE:** Never place anything but the key into the slot of the lug door switch.

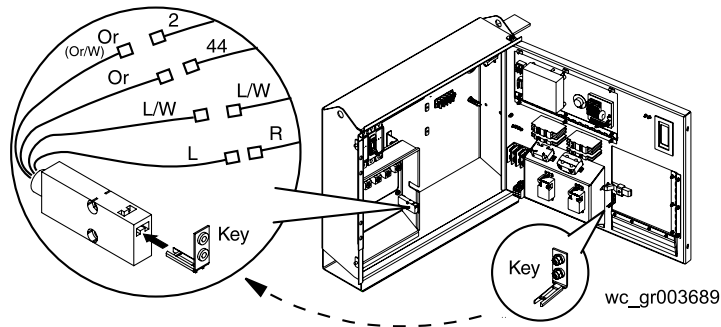

- Disconnect the blue and blue/white wires of the lug door switch. Also disconnect the orange wires (orange and orange/white wires on older machines) of the lug door switch.
- Check for continuity between the blue and blue/white wires.

Is there continuity?

Yes _____	No _____
Continue	The lug door switch has failed; replace it.

- Remove the key from the lug door switch.
- Check for continuity between the blue and blue/white wires.

Is there continuity?

Yes _____	No _____
The lug door switch has failed; replace it.	Reconnect the blue and blue/white wires; then continue.

- Check for continuity between the orange wires (orange and orange/white wires on older machines).

Is there continuity?

Yes _____	No _____
Continue	The lug door switch has failed; replace it.

- Place the key into the lug door switch.
- Check for continuity between the orange wires (orange and orange/white wires on older machines).

Is there continuity?

Yes _____	No _____
The lug door switch has failed; replace it.	The lug door switch is OK.

- Reconnect the blue and blue/white wires to the lug door switch. Also reconnect the orange wires (orange and orange/white wires on older machines).
- Re-install the key (latch) to the lug door. (**Note:** leave key disconnected if moving to the next check.)

The lug door switch has now been checked. Continue with *Checking the Main Circuit Breaker*.

8.3 Checking the Main Circuit Breaker

- Prerequisites**
- Fully-charged battery
 - Emergency stop switch in disengaged (out) position.

Procedure Follow the procedure below to check the main circuit breaker. As a reminder, place a check mark next to the answer that applies.

1. With the lug door closed, place the main circuit breaker in the ON position.

Does the main circuit breaker stay in the ON position?

Yes _____	No _____
Continue	The main circuit breaker has failed; replace it.

2. With the main circuit breaker in the ON position, open the lug door.

Does the main circuit breaker trip?

Yes _____	No _____
Continue	The main circuit breaker has failed; replace it.

3. Open the large hinged panel and disconnect the yellow (Y) wire leading to the shunt of the main circuit breaker.

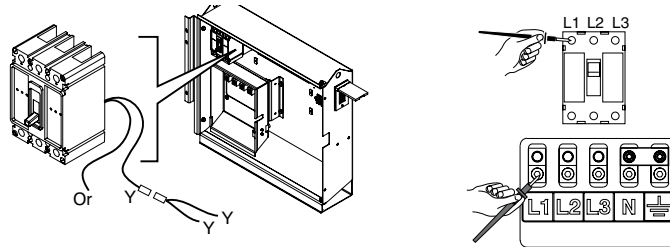

4. Place the main circuit breaker in the ON position.

Does the main circuit breaker stay in the ON position?

Yes _____	No _____
Continue	The main circuit breaker has failed; replace it.

5. With the main circuit breaker in the ON position, check for continuity (continuity equals 0.0–1.0 Ohms) between L1 of the main circuit breaker and Lug 1. Also check between L2 and Lug 2, and L3 and Lug 3.

Is there continuity for each check?

Yes _____	No _____	Your readings
Continue	The main circuit breaker has failed; replace it.	____; ____; ____

6. With the main circuit breaker in the OFF position, check for continuity between L1 of the main circuit breaker and Lug 1. Also check between L2 and Lug 2, and L3 and Lug 3.

Is there continuity for any of the checks?

Yes _____	No _____
The main circuit breaker has failed; replace it.	The main circuit breaker is functioning properly.

7. Reconnect the yellow (Y) wire.

The main circuit breaker has now been checked. Continue with *Checking the Voltage Adjusting Rheostat*.

8.5 Checking the Auxiliary Winding

Prerequisites ■ Generator shut down

Procedure Follow the procedures below to check the auxiliary winding.

1. Open the large hinged panel and locate the Automatic Voltage Regulator (AVR).

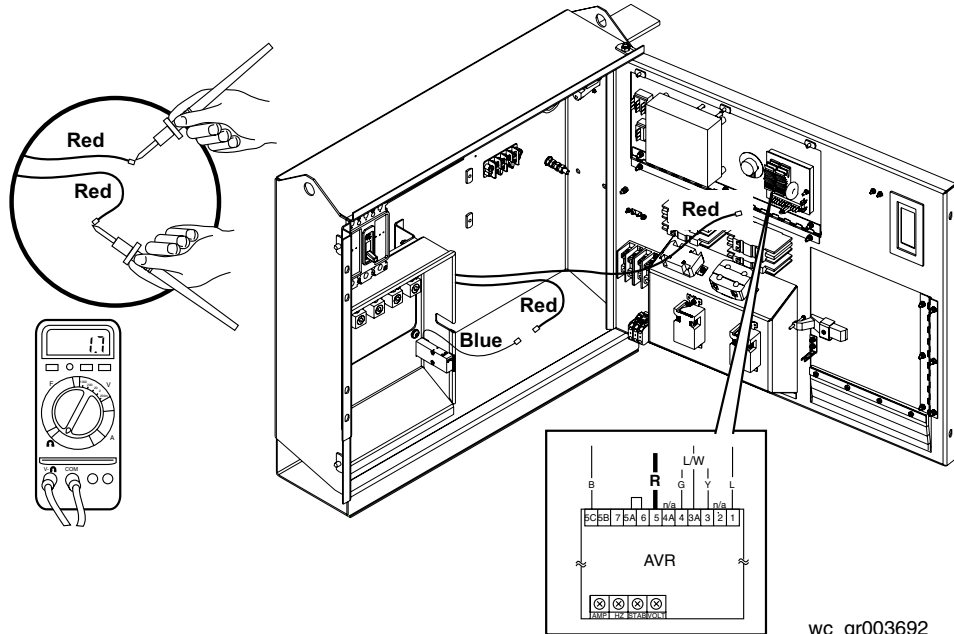

wc_gr003692

2. Disconnect the red wire from the AVR.
3. Disconnect the red wire from the blue wire of the lug door switch.
4. Measure the resistances across the two red wires.

Is 1.7–2.7 Ohms measured?

Yes _____	No _____	Your reading
Continue	Remove the vent cover from the generator and check the generator for damage.	

5. Check each red wire for continuity to ground.

Does each wire measure "OPEN" or "OL" to ground?

Yes _____	No _____	Your reading
Auxiliary winding is OK.	Remove the vent cover from the generator and check the generator for damage.	

6. Reconnect the wiring.

The auxiliary winding has now been checked. Continue with *Checking the Exciter Stator*.

8.6 Checking the Exciter Stator

Prerequisites ■ Generator shut down

Procedure Follow the procedure below to check the exciter stator.

1. Open the large hinged panel and locate the Automatic Voltage Regulator (AVR).

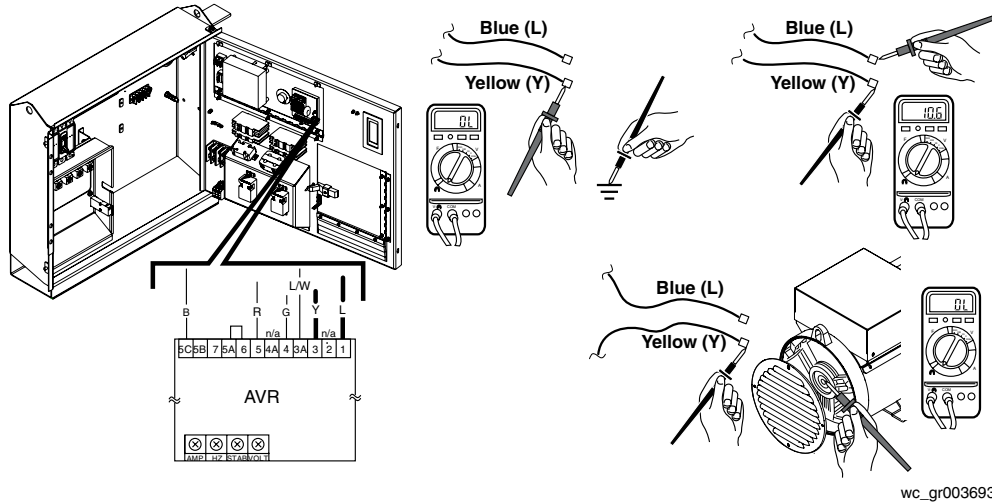

2. Disconnect the blue and yellow wires from the AVR.
3. Measure the continuity between the blue wire and ground. Also measure between the yellow wire and ground.

Does each wire measure "OPEN" or "OL" to ground?

Yes _____	No _____	Your reading
Continue	Remove the vent cover from the generator and check the generator for damage.	

4. Measure the resistance across the blue and the yellow wires.

Is 10.6–12.0 Ohms measured?

Yes _____	No _____	Your reading
Continue	Remove the vent cover from the generator and check the generator for damage; then continue.	

5. Remove the vent cover from the generator to expose the rotor.
6. Measure the continuity between the blue wire and the rotor. Also measure between the yellow wire and the rotor.

Does each wire measure "OPEN" or "OL" to the rotor?

Yes _____	No _____	Your reading
The exciter stator is OK.	The exciter stator has failed. Call Wacker Service.	

7. Reconnect the wiring, and re-install the vent cover.

The auxiliary winding has now been checked. Continue with *Checking the AVR Sensing Wires*.

8.7 Checking the AVR Sensing Wires

Prerequisites ■ Generator shut down

Procedure Follow the procedure below to check the AVR sensing wires.

1. Open the large hinged panel and locate the Engine Control Module (ECM) and the Automatic Voltage Regulator (AVR).

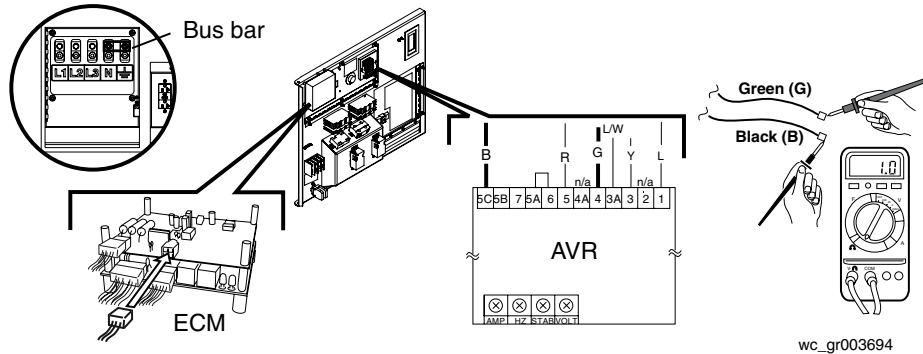

2. Disconnect the 4-pin connector (it has 3 wires) from the ECM.
3. Remove the green and black wires from the AVR.
4. Measure the resistance across the green and black wires.

Is 0.2–1.0 Ohms measured?

Yes _____	No _____	Your reading
Continue	Remove the vent cover from the generator and check the generator for damage.	

5. Measure the resistance between the green wire and the ground lug. Also check between the black wire and the ground lug.

Is 0.2–1.0 Ohms measured?

Yes _____	No _____	Your reading
Continue	Remove the vent cover from the generator and check the generator for damage.	

6. Remove the bus bar between the neutral lug and the ground lug.
7. Measure the continuity between the green wire and the ground lug. Also check between the black wire and the ground lug.

Does each wire measure "OPEN" or "OL" to the ground lug?

Yes _____	No _____	Your reading
The sensing wires are OK.	Remove the vent cover from the generator and check the generator for damage.	

8. Reconnect the 4-pin connector and the green and black wires to the AVR.
NOTICE: NEVER run the generator when the green and black wires are disconnected from the AVR and all other wires are connected to the AVR. Damage to the generator will occur.
9. Reconnect the bus bar. **DO NOT run the generator with the bus bar disconnected.** The AVR sensing wires have now been checked. Continue with *Flashing the Generator*.

8.8 Flashing the Generator (checking the excitation system)

Prerequisites ■ Source of 12VDC

Procedure Follow the procedure below to flash the generator.

1. Open the large hinged panel and locate the Automatic Voltage Regulator (AVR).

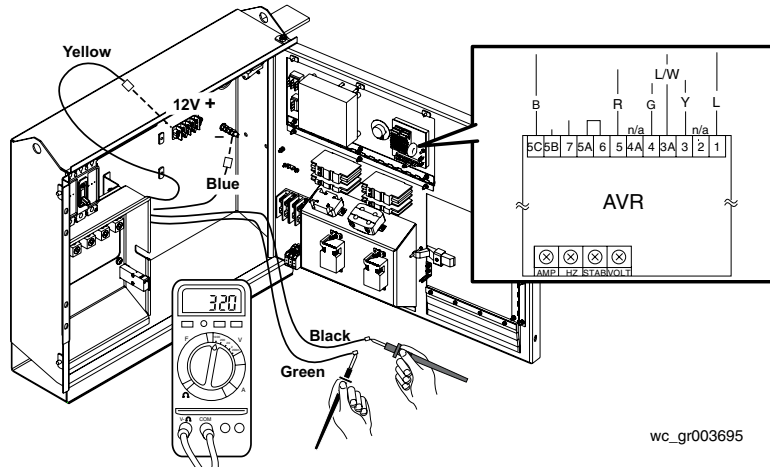

2. Disconnect all the wires from the AVR except the rheostat wires and the white jumper wire.
3. Connect a multimeter (set to the 500VAC or higher scale) to the green and black wires.



WARNING! Electric shock hazard. High voltage exists between the green and black wires when the engine is running. Electric shock can cause injury or death. Do not touch the green and black wires.

4. Start the engine. Then, connect the blue wire to the ground lug and the yellow wire to the B+ terminal strip. **NOTICE:** Do not connect the wires to the machine without the engine running. Damage to the winding may occur.
5. Check the multimeter for the voltage measured across the green and black wires.
Is 320±50V measured? (170±25V on: 0009369 rev. 100-105, 0009459 rev. 100-105, 0620003 rev. 100-106)

Yes _____	No _____	Your reading
The excitation system is functioning properly. Continue	Check the exciter rotor winding. See <i>Checking the Exciter Rotor Winding</i> .	

6. Shut down the generator. Then, reconnect all the wires to the AVR.

7. Start the engine and check the function of the generator.

Does the generator now function properly?

Yes _____	No _____
The generator should be OK.	The AVR has failed; replace it.

The excitation system has now been checked. Continue with *Checking the Stator Windings at the Lugs*.

8.9 Checking Stator Windings at the Lugs

- Prerequisites**
- Generator shut down
 - Two alligator clips each connected to 12 inches of 14-gauge wire

Procedure Follow the procedure below to check the stator windings at the lugs.

1. Place the voltage selector switch in the 480/277 position.
2. Open the lug door. Connect the alligator clips/wires to Lug 1 and to the neutral lug (N).
3. Close the lug door and place the main circuit breaker in the ON (closed) position.
4. Measure the resistance between Lug 1 and the neutral lug. Enter the reading in the table below. Also measure the resistance between Lug 2 and the neutral lug, and lug 3 and the neutral lug. Enter these values in the table below.

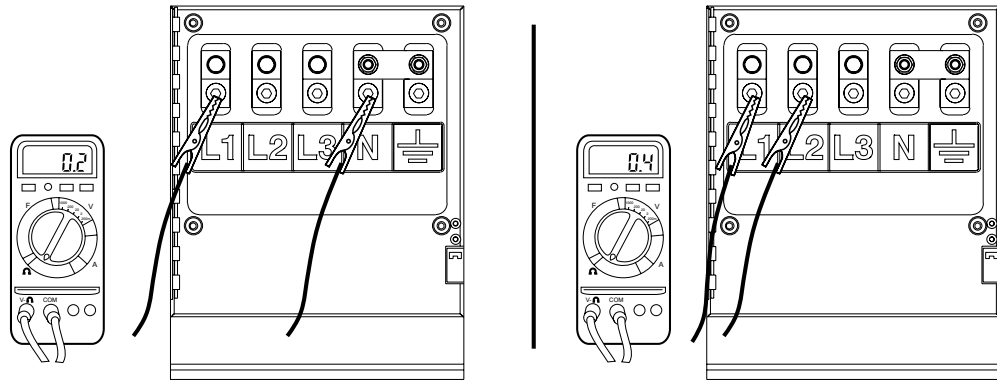

wc_gr003931

5. Measure the resistance between Lug 1 and Lug 2; Lug 1 and Lug 3; and Lug 2 and Lug 3. Enter these values into the table below. All values are in Ohms.

480/277 position	L1-N	L2-N	L3-N	L1-L2	L2-L3	L1-L3
Ideal	0.2	0.2	0.2	0.4	0.4	0.4
Your reading						

Are your readings approximately equal to the ideal measurements?

Yes _____	No _____
The main stator windings and the voltage selector switch are OK.	<ol style="list-style-type: none"> 1. Clean the voltage selector switch with contact cleaner. 2. Check the windings at the generator. See <i>Checking Stator Windings at the Voltage Selector Switch</i>.

The stator windings have now been checked at the lugs. Continue with *Checking the Rectifier Diodes*.

8.10 Checking the Rectifier Diodes

Prerequisites ■ Generator shut down

Procedure Follow the procedures below to check the rectifier diodes.

1. Remove the rear baffle from the machine.

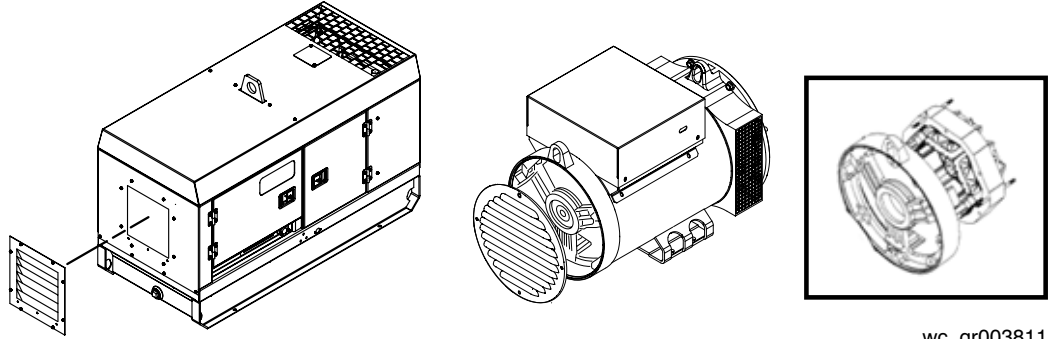

wc_gr003811

2. Remove the cover from the generator.
3. Remove the screws that secure the bearing carrier to the stator.
4. Disconnect the blue and yellow wires from the AVR.
5. Using a puller, pull the bearing carrier/exciter stator from the stator housing.
6. Disconnect the diode's lead from the terminal. Note the rubber washer isolating the lead from the diode plate.

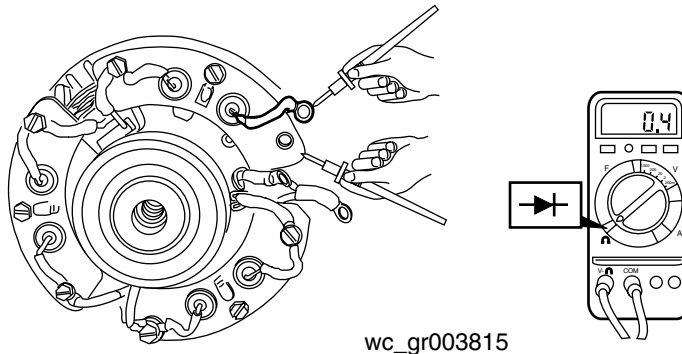

wc_gr003815

7. Using the diode scale on your multimeter, check each diode between the diode's lead and the diode plate. Reverse the probes of your meter and check the diode again. Each diode should conduct in one direction and not in the other. Your meter should read 0.4–0.5V in the direction that conducts.

Does each diode check OK?

Yes	No
The diodes are OK.	Replace all diodes. Call Wacker Service.

8. Reconnect the AVR.
9. Reconnect the diodes. Be sure to include the washer when reconnecting the diode lead. The rectifier diodes have now been checked. Continue with *Checking the Main Rotor Winding*. **Note:** If moving on to the next test, leave the generator disassembled.

8.11 Checking the Main Rotor Winding

Prerequisites ■ Generator shut down

Procedure Follow the procedure below to check the main rotor winding.

1. Remove the rear baffle from the machine.

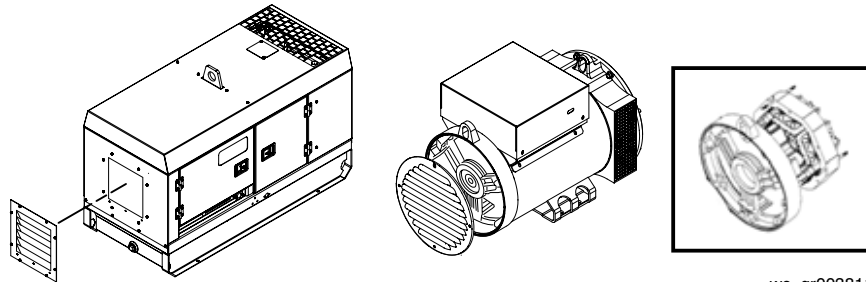

wc_gr003811

2. Remove the cover from the generator.
3. Remove the screws that secure the bearing carrier to the stator.
4. Disconnect the blue and yellow wires from the AVR.
5. Using a puller, pull the bearing carrier/exciter stator from the stator housing.
6. Disconnect the wires to the main rotor winding. One is marked with a red tag and the other is marked with a blue tag.

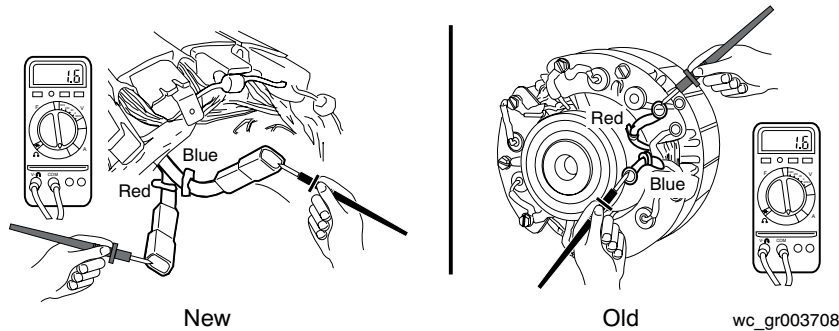

wc_gr003708

7. Measure the resistance across the two wires.

Is 1.4–3 Ohms measured?

Yes _____	No _____	Your reading
Continue	The main rotor winding has failed. Call Wacker Service.	

8. Check each wire for short (path) to the rotor shaft.

Does each wire measure "OPEN" or "OL" to the rotor shaft?

Yes _____	No _____	Your reading
The main rotor winding is OK.	The main rotor winding has failed. Call Wacker Service.	

The main rotor winding has now been checked. Continue with *Checking the Exciter Rotor Winding*. **Note:** If moving on to the next test, leave the generator disassembled.

8.12 Checking the Exciter Rotor Winding

Prerequisites ■ Generator shut down

Procedure Follow the procedure below to check the exciter rotor winding.

1. Remove the rear baffle from the machine.

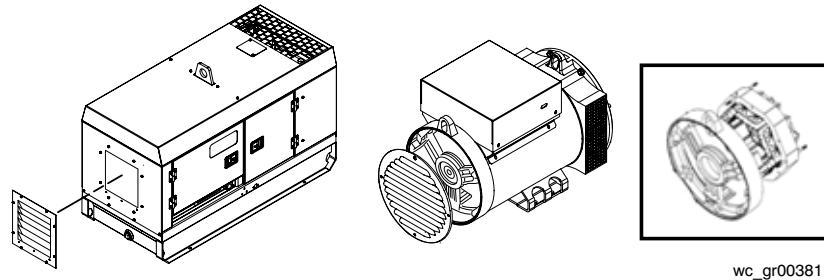

wc_gr003811

2. Remove the cover from the generator.
3. Remove the screws that secure the bearing carrier to the stator.
4. Disconnect the blue and yellow wires from the AVR.
5. Using a puller, pull the bearing carrier/exciter stator from the stator housing.
6. On older machines, remove the exciter rotor leads from the diode plates. The three exciter rotor leads are connected to the diode plates in between each pair of diodes. Or, remove the diode plates completely to access the exciter rotor leads.

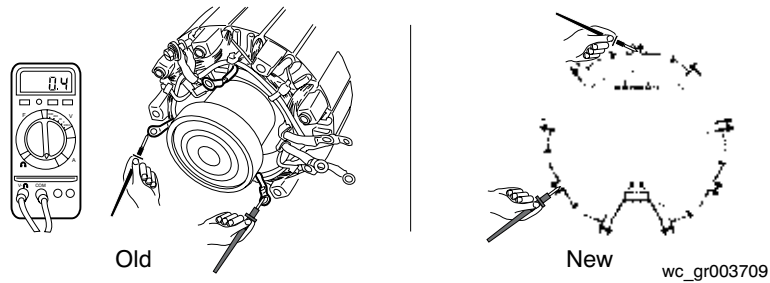

wc_gr003709

7. On newer machines, the location of the three exciter rotor leads is also in between each pair of diodes.
8. Measure the resistance across each lead and the other two leads (one lead at a time).
Is 0.3–1.0 Ohms measured in each case?

Yes _____	No _____	Your readings
The exciter rotor windings are OK.	The exciter rotor has failed. Call Wacker Service.	____; ____; ____

9. Check each lead for short (path) to the rotor shaft.
Does each lead measure "OPEN" or "OL" to the rotor shaft?

Yes _____	No _____	Your reading
The main rotor winding is OK.	The main rotor winding has failed. Call Wacker Service.	

10. Reassemble the generator components.

The exciter rotor winding has now been checked. Continue with *Checking the Main Stator Windings at the Voltage Selector Switch*.

8.13 Checking Stator Windings at the Voltage Selector Switch

Prerequisites ■ Generator shut down

- Procedure**
1. Follow the procedure below to check the main stator windings at the generator.
 2. Remove the cover from the Voltage Selector Switch (VSS).

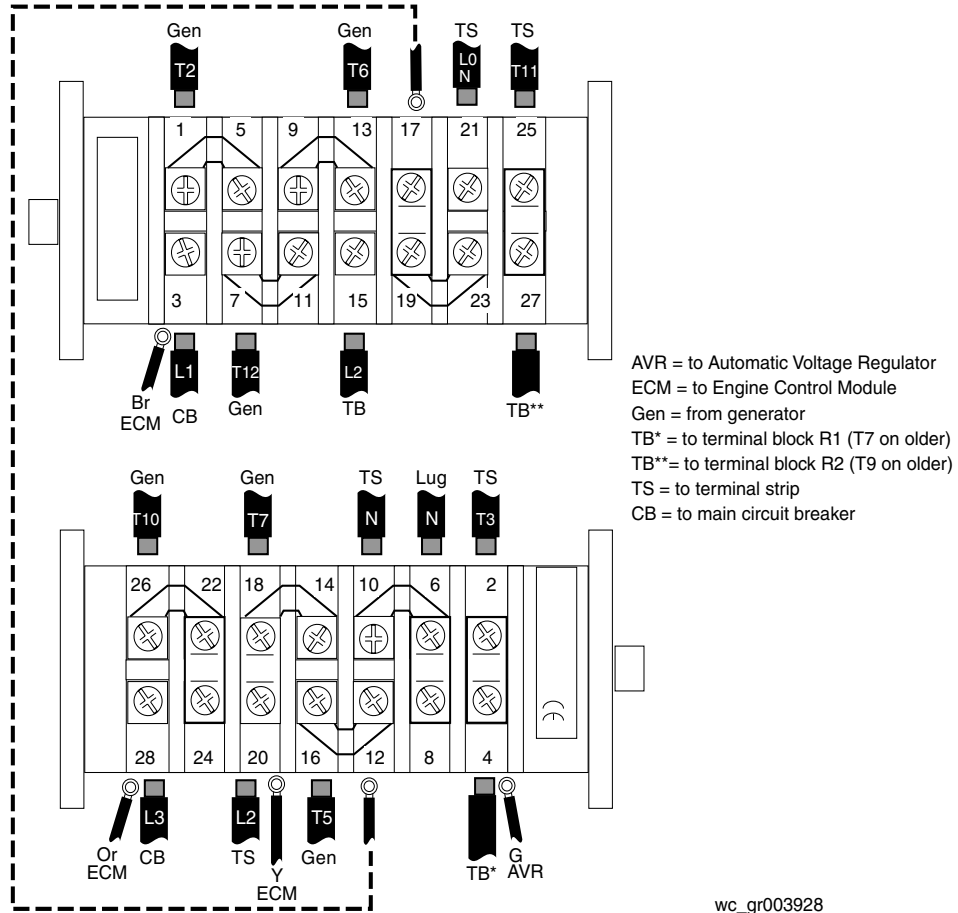

3. Note the positions and labels of all wires connected to the VSS (T2, T3, T4 etc.).
4. Check the resistance across each pair of wires for each winding (T1–T2, T3–T4, and so on up to T11–T12). **Note:** T1, T4, T8, and T9 are located at the terminal strip.

	T1–T2	T3–T4	T5–T6	T7–T8	T9–T10	T11–T12
Your readings						

Do all six stator windings measure approximately 0.2 Ohms?

Yes_____	No_____
The main stator windings are OK. If there is a difference between the readings taken here and those taken at the lugs, the VSS has failed; replace it.	The main stator windings have failed. Call Wacker Service.

5. Reconnect the wires and reinstall the generator components.
 The main stator windings have now been checked.

9. Disassembly/Assembly Procedures

9.1 Tools

Because all possible problems encountered while repairing the machine cannot be anticipated, it is up to the mechanic to use common sense and good judgement in tool selection.

The use of any special tools is recommended only for those operations where the use of conventional tools proves inadequate.

Before substituting another tool or procedure, you should be satisfied that neither personal injury nor damage to the component will result.

9.2 Ordering Parts

The repair procedures contained in this manual do not include part numbers. For parts replacement information, refer to the Parts Book originally supplied with the machine.

If the original Parts Book has been lost, a replacement may be ordered from Wacker Corporation. When ordering a replacement Parts Book, please list the model number, item number, revision level, and serial number of the machine. Parts Books are also available on the Wacker Corporation Web site. See www.wackergroup.com. Enter the site as a visitor.

9.3 Reference Numbers ()

Repair procedures contain reference numbers enclosed in parentheses (). These numbers refer to the item numbers shown on the assembly drawings and other detailed drawings. They are included to aid the mechanic in identifying parts and assembling components.

9.4 Weight Block

See Graphic: *wc_gr000843*

The weight block symbol gives an approximate weight measurement to aid the mechanic when lifting/hoisting larger components.



wc_gr000843

9.5 Removing the Roof

See Graphic: *wc_gr003320*

This procedure requires an appropriate crane capable of lifting 227 kg (500 lbs.).

- 9.5.1 Disconnect the battery.
- 9.5.2 Remove the doors **(a)**.
- 9.5.3 Remove the front and rear access panels **(b and c)**.
- 9.5.4 Remove the screws that secure the roof to the side panels **(d)**.
- 9.5.5 Remove the screws that secure the control panel enclosure **(e)** to the lifting structure **(f)**.
- 9.5.6 Remove the screws that secure the door latch **(g)** to the lifting structure and remove the door latch.
- 9.5.7 Remove the screws that secure the lifting structure to the frame.
- 9.5.8 Using an appropriate crane or hoist, lift the roof **(h)**, by the lifting eye, off of the frame.

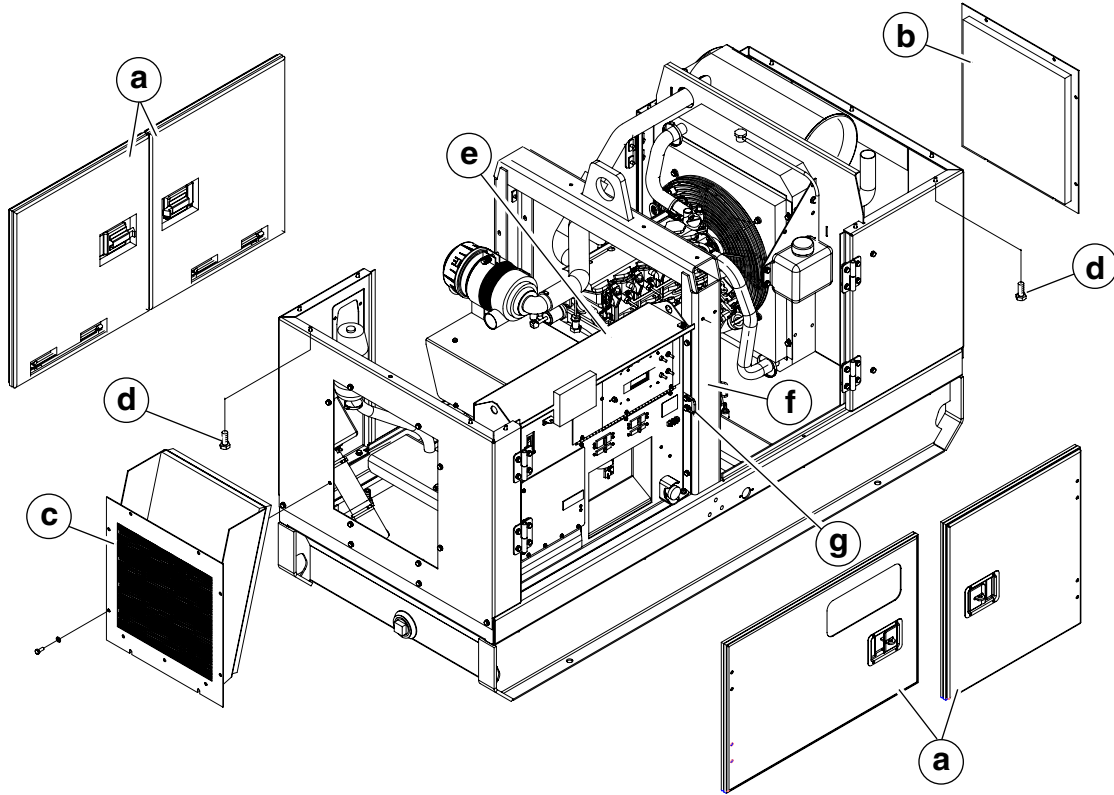

wc_gr003320

9.6 Preparing Unit for Generator Removal

See Graphic: *wc_gr003321*

- 9.6.1 Remove the roof. See section *Removing Roof*.
- 9.6.2 Remove the screws that secure the air filter assembly and set the air filter assembly off to the side.
- 9.6.3 Remove the cover to the VSS box.
- 9.6.4 Cut the wire tie **(a)** that secures the wiring to the engine.
- 9.6.5 Disconnect the ground strap **(b)** between the generator and the frame.
- 9.6.6 Disconnect the ground strap **(c)** between the engine and the control panel enclosure.
- 9.6.7 Disconnect the fuel line **(d)** from the fuel filter.
- 9.6.8 Disconnect the wires from the Automatic Voltage Regulator (AVR) **(e)**: blue from term 1, yellow from term 3, blue-white from term 3A, green from term 4, red from term 5, and black from term 5C. Cut the wire ties that secure the wires.
- 9.6.9 Disconnect the other AVR wires **(f)**: red wire from the lighter gauge blue wire, blue-white wire at the connector to the lighter gauge blue-white wire.
- 9.6.10 Cut the wire tie then disconnect the connector **(g)** holding wire L1 to wire #1 from the generator. Also cut the wire tie and disconnect the connector holding wire L3 to wire #9 from the generator.
- 9.6.11 Cut the wire ties **(h)** that secure the rest of the generator wires.
- 9.6.12 Disconnect the generator wires from the VSS.
- 9.6.13 Remove the screws that secure the door hinges **(i)** and remove the hinges.
- 9.6.14 Lift and rotate the control panel enclosure **(j)** approximately 90° to obtain access to the generator. Support the control panel enclosure in this position.

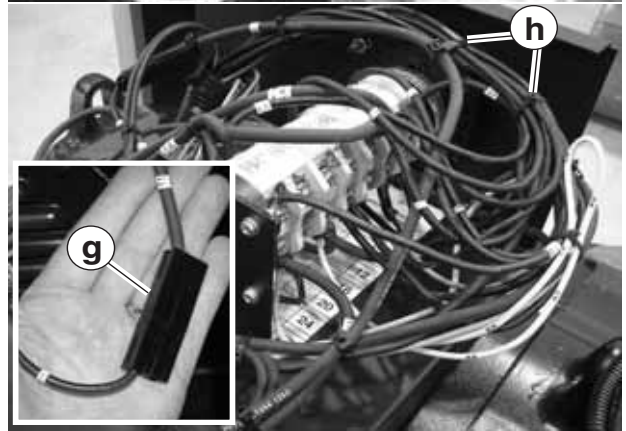
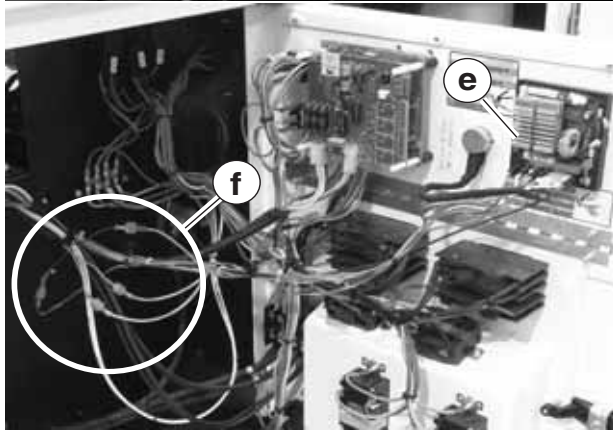
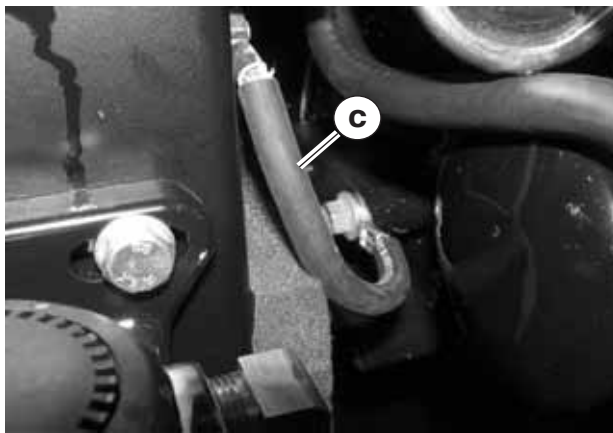
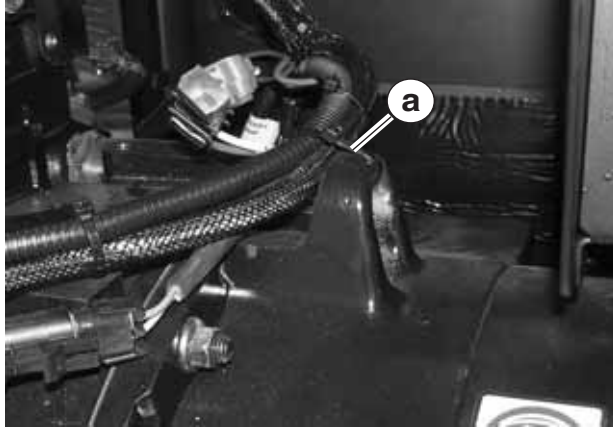

wc_gr003321

9.7 Replacing the Generator

See Graphic: *wc_gr003322*

This procedure requires an appropriate crane capable of lifting 365 kg (800 lbs.).

Removal:

- 9.7.1 See section *Preparing Unit for Generator Removal*.
- 9.7.2 Remove the screens **(a)** from both sides of the generator housing.
- 9.7.3 Remove the screws **(b)** that secure the shock mounts to the frame.
- 9.7.4 Support the engine from underneath and the generator from above.
- 9.7.5 Remove the screws **(c)** that mount the flex plates to the engine. Reposition the flex plates by turning the generator fan.
- 9.7.6 Remove the screws **(d)** that secure the generator to the engine.
- 9.7.7 Using an appropriate crane or hoist, lift the generator up and away from the engine.

Installation:

- 9.7.8 Position the generator into the frame.
- 9.7.9 Using Loctite 231 or equivalent on the screws **(d)**, secure the generator to the engine. Torque the screws to 69Nm (50 ft.lbs.).
- 9.7.10 Using Loctite 231 or equivalent on screws **(c)**, secure the flex plates to the engine. Torque the screws to 45 Nm (33 ft.lbs.); 35Nm (25 ft.lbs.) on G 25 models.
- 9.7.11 Using screws **(b)**, secure the shock mounts to the frame.
- 9.7.12 Secure the screens **(a)** to both sides of the generator housing.
- 9.7.13 Reconnect all wiring.
- 9.7.14 Reinstall the control panel enclosure and the roof.

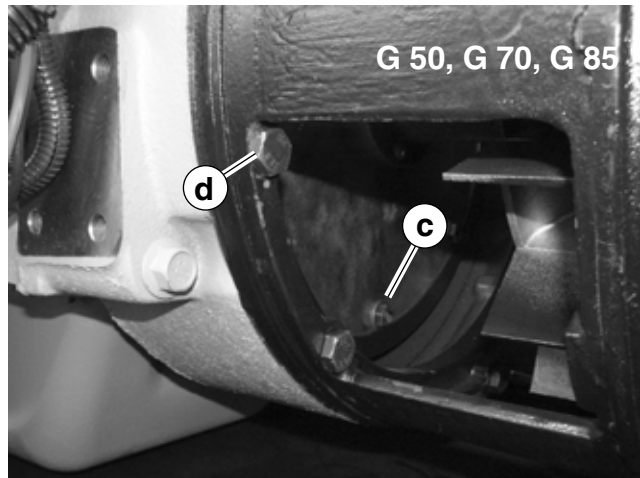
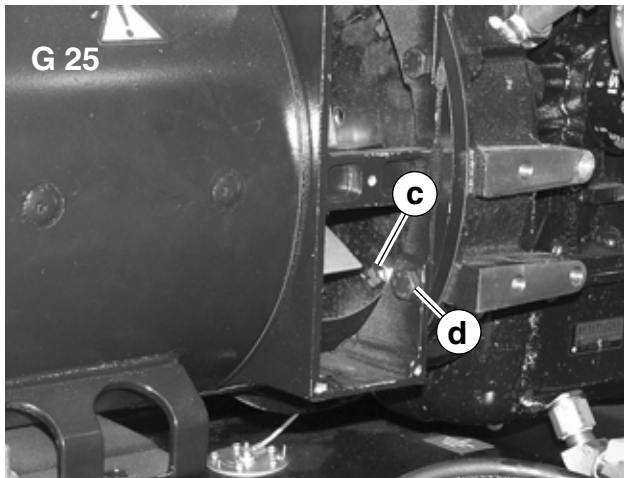
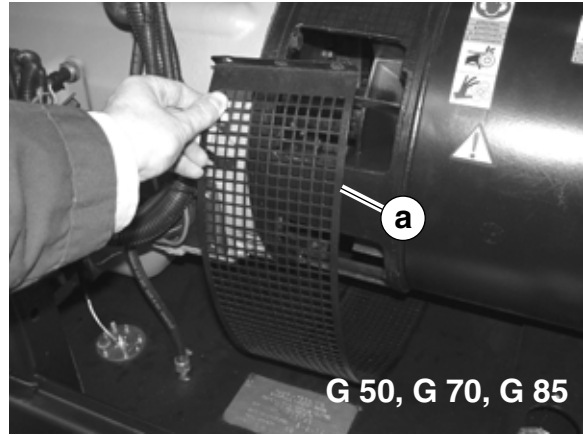
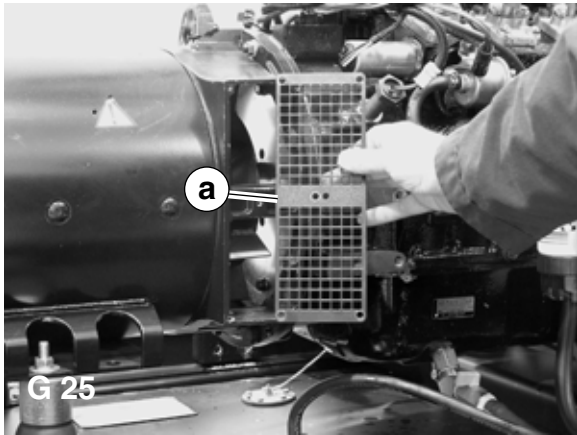

wc_gr003322

9.8 Removing the AVR

Prerequisites

Machine shut down

Procedure

Follow the procedure below to remove the Automatic Voltage Regulator (AVR).

1. Remove the screws that secure the large access panel **(a)** and open the large access panel.

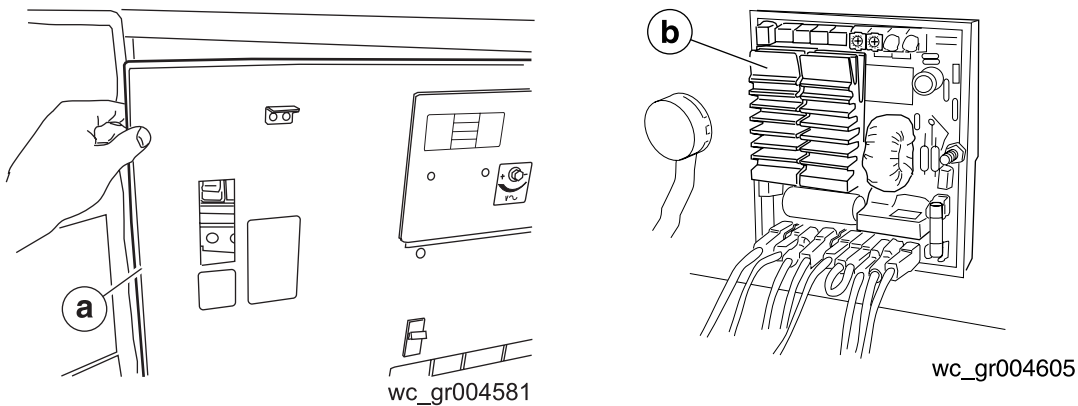

2. Make note of the wires connected to the AVR **(b)**.
3. Disconnect the wires.
4. Remove the screws that secure the AVR and remove the AVR from the machine.

The procedure to remove the AVR is now complete.

9.9 Installing the AVR

Prerequisites

- Machine shut down
- Multimeter

Procedure

Follow the procedure below to install and set the Automatic Voltage Regulator (AVR).

1. Check the function of the voltage adjusting rheostat. See section *Checking the Voltage Adjusting Rheostat*.
2. Mount the AVR **(b)** to the machine with the two screws.

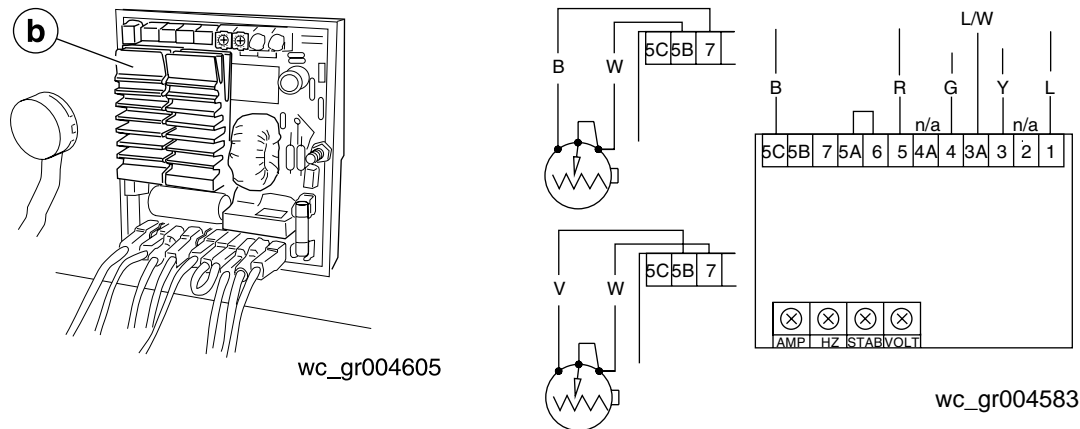

3. Reconnect the wires to the AVR.
4. Adjust the VOLT pot **(a)** on the new AVR counterclockwise as far as possible.

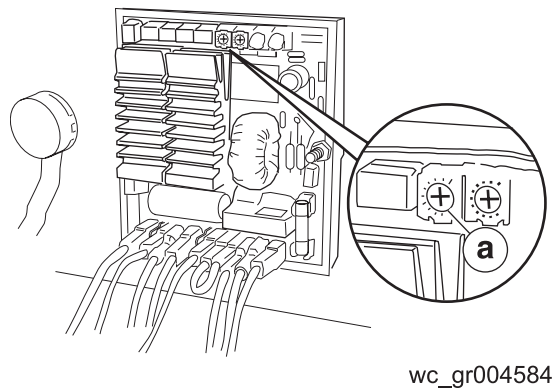

WARNING! Electric shock hazard. Voltage exists at the cooling fins of the AVR when the engine is running. Electric shock can cause severe injury or death.

- ▶ Never touch the cooling fins when the engine is running.

5. Place the voltage selector switch in the 208/120V position.

NOTICE: Never adjust the AVR voltage pot with the voltage selector switch in any other position. Damage to the generator may occur.

This procedure continues on the next page.

Continued from the previous page.

6. Loosen the locknut and adjust the voltage adjusting rheostat (c) clockwise as far as possible.

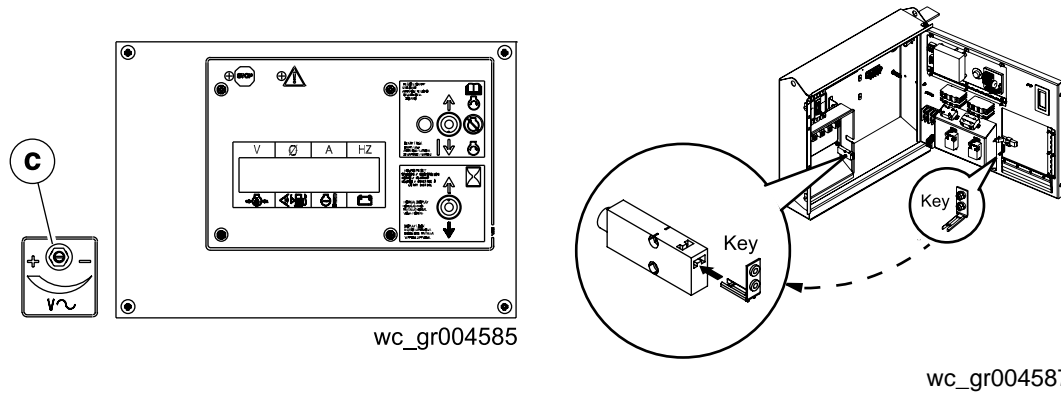

7. Open the large hinged panel. Remove the “key” (latch) from the lug door and place it in the slot of the lug door switch. **NOTICE:** Never place anything but the key into the slot of the lug door switch.

8. Place the main circuit breaker in the ON position.



WARNING! Electric shock hazard. High voltage exists at the lugs when the engine is running. High voltage can kill or cause severe injury.

► Never touch the lugs when the engine is running.

9. Start the machine.

NOTICE: Shut down the machine immediately if any load (change in engine rpm) on the generator is sensed. A change in engine rpm indicates incorrect wiring. Check the wiring.

10. Check the voltage between Lug 1 and Lug 2 with a multimeter.

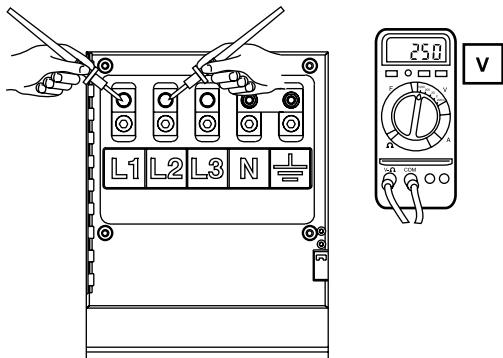

wc_gr004590

11. Adjust the VOLT pot of the AVR until 250VAC is measured between Lug 1 and Lug 2. *This procedure continues on the next page.*

Mobile Generator Repair Disassembly/Assembly Procedures

Continued from the previous page.

12. Test the consistency by checking the voltage across Lug 1 and Lug 2, Lug 2 and Lug 3, Lug 3 and Lug 1. Then, check the voltage between each lug and Neutral. Approximately 139V should be measured.
13. Shut down the machine. Change the voltage selector switch to the 480/277 position.
14. Start the machine.
15. Measure the voltage between Lug 1 and Lug 2. Adjust the voltage adjusting rheostat until 480V is measured. Tighten the lock nut.
16. Test the consistency of the voltage by checking across Lug 1 and Lug 2, Lug 2 and Lug 3, Lug 3 and Lug 1. Then, check the voltage between each lug and Neutral. Approximately 277V should be measured.
17. Check the consistency between the voltage measured at the lugs by the multimeter and that shown on the ECM display. If the ECM display is off by more than 2%, adjust the VOLT pot on the ECM so that the ECM display matches the reading on the multimeter.

NOTICE: Only adjust the ECM pot while in the 480/277V position.

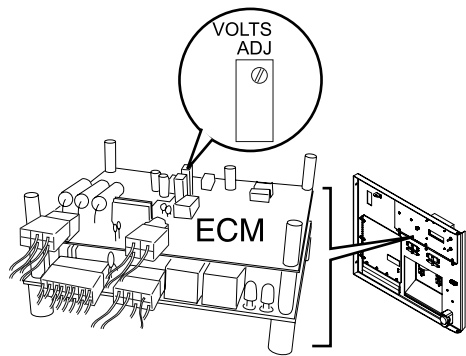

wc_gr004589

18. Shut down the machine.
19. Re-install the "key" (latch) to the lug door.
20. Close the large access panel and secure it with two screws.

The procedure to install and set the AVR is now complete.

9.10 Removing the Engine

See *Graphic: wc_gr003351*

This procedure requires an appropriate crane capable of lifting 1000 kg (2200 lbs.).

- 9.10.1 Remove the roof. See section *Removing the Roof*.
- 9.10.2 Remove the generator. See section *Removing the Generator*.
- 9.10.3 Remove the battery.
- 9.10.4 Disconnect the wiring harness **(a)** from the engine.
- 9.10.5 Disconnect and plug the fuel line **(b)** at the fuel filter.
- 9.10.6 Using an appropriate hoist or crane, lift the control panel enclosure from the frame.
- 9.10.7 Drain the radiator.
- 9.10.8 Disconnect the radiator hoses **(c)** from the engine.
- 9.10.9 Disconnect the exhaust pipe **(d)** from the engine. Loosen the clamp at the muffler and rotate the exhaust pipe away from the engine.
- 9.10.10 Disconnect the fuel return line **(e)**.
- 9.10.11 Remove the fan guard **(f)**.
- 9.10.12 Disconnect the ground strap **(g)** from the engine.
- 9.10.13 Disconnect the engine from the frame by removing the screws that secure the shock mounts.
- 9.10.14 Using as appropriate hoist or crane, lift the engine up and out of the frame.

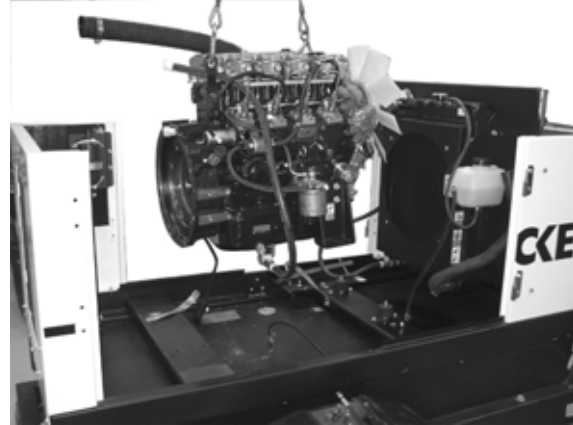
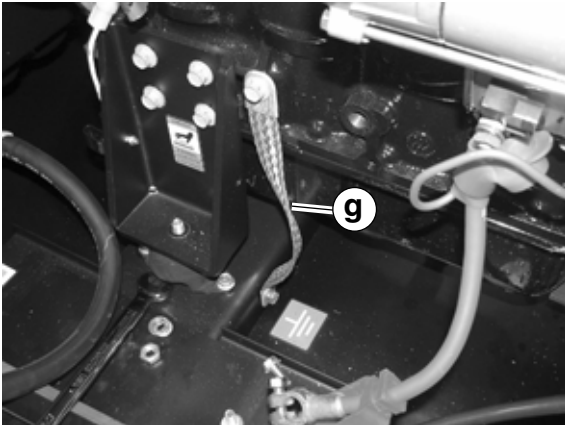
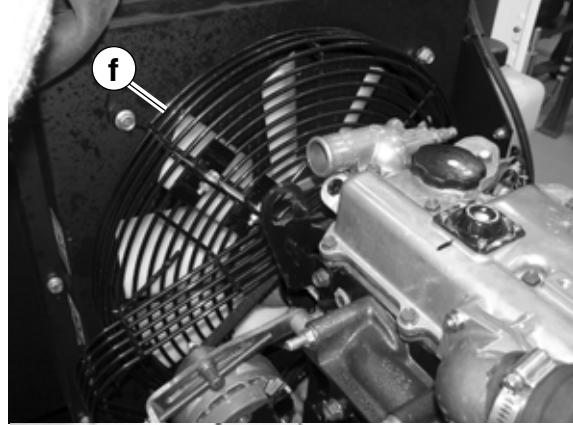
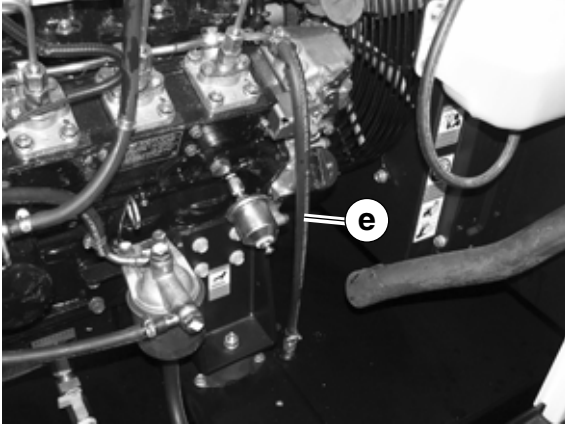
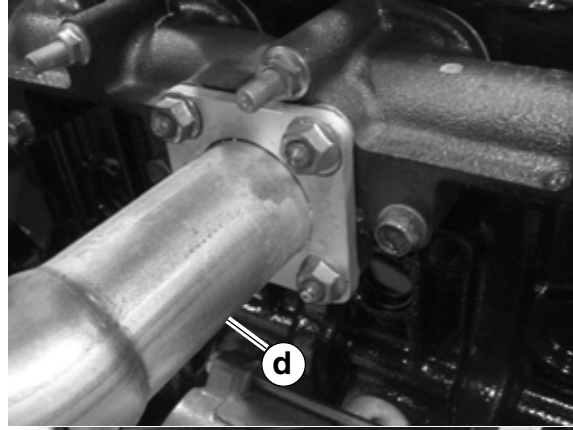
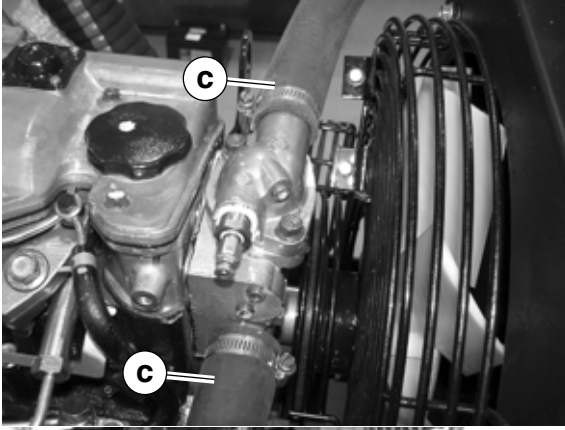
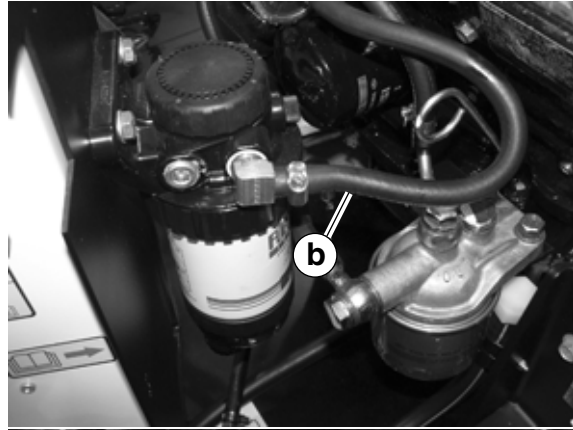
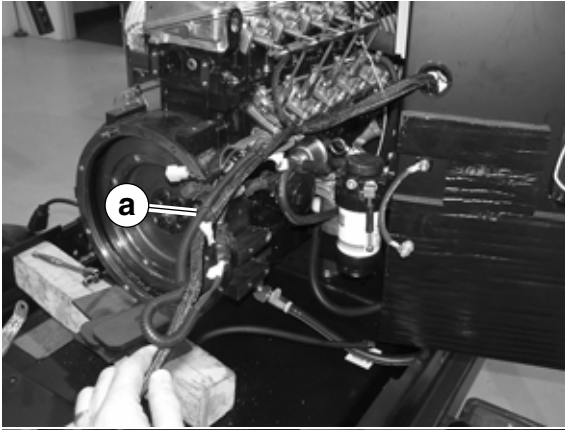

wc_gr003351

9.11 Installing the Engine

See Graphic: *wc_gr003352*

This procedure requires an appropriate crane capable of lifting 1000 kg (2200 lbs.).

- 9.11.1 Using as appropriate hoist or crane, lower the engine into the frame.
- 9.11.2 Secure the engine to the frame with the screws that secure the shock mounts.
- 9.11.3 Connect the ground strap **(g)** to the engine.
- 9.11.4 Install the fan guard **(f)**.
- 9.11.5 Connect the fuel return line **(e)**.
- 9.11.6 Connect the exhaust pipe **(d)** to the engine. Tighten the clamp at the muffler.
- 9.11.7 Connect the radiator hoses **(c)** to the engine.
- 9.11.8 Fill the radiator with coolant.
- 9.11.9 Using an appropriate hoist or crane, lower the control panel enclosure onto the frame.
- 9.11.10 Connect and the fuel line **(b)** to the fuel filter.
- 9.11.11 Connect the wiring harness **(a)** to the engine. Secure the harness as necessary with wire ties.
- 9.11.12 Install the battery.
- 9.11.13 Install the generator. See section *Replacing the Generator*.
- 9.11.14 Install the roof.

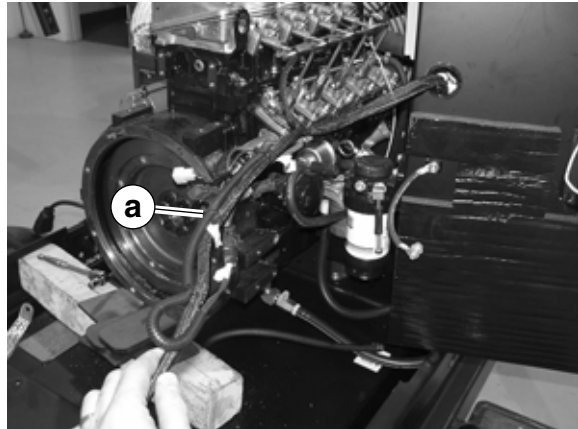
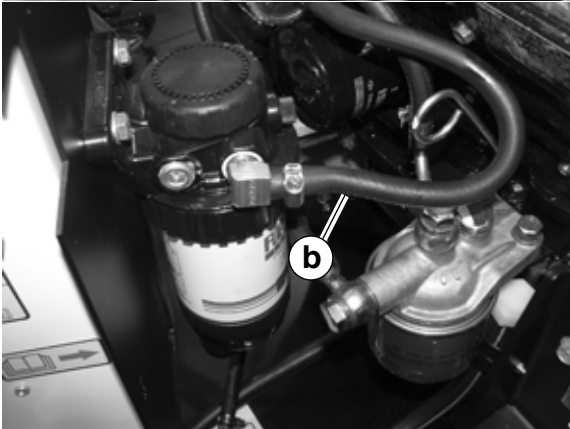
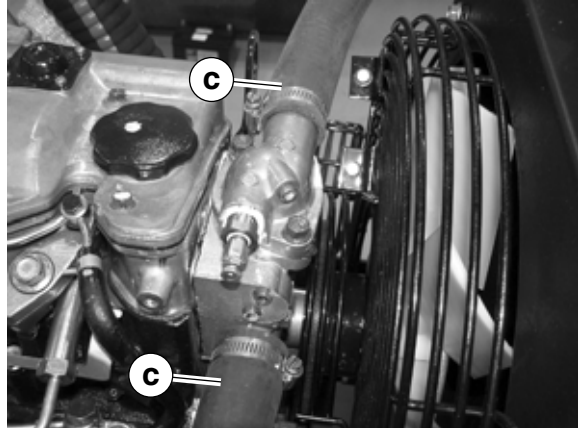
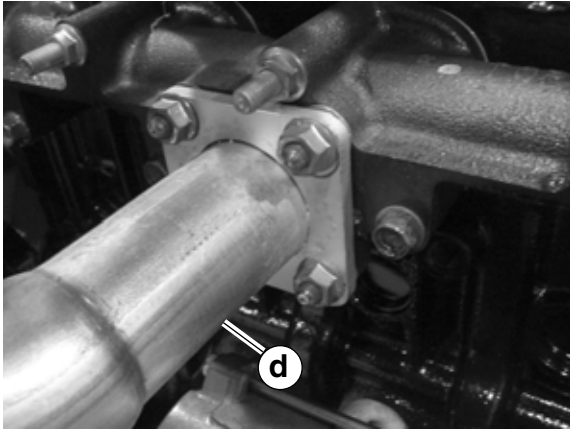
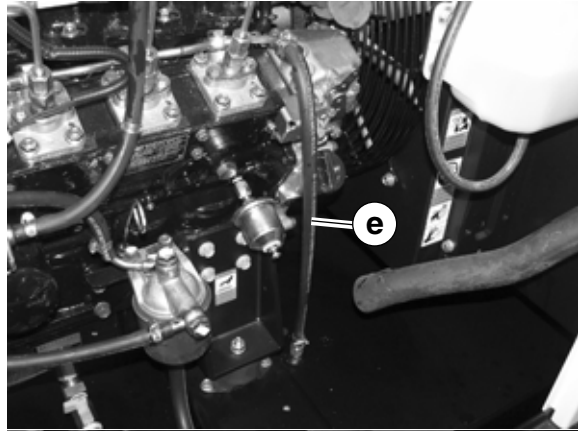
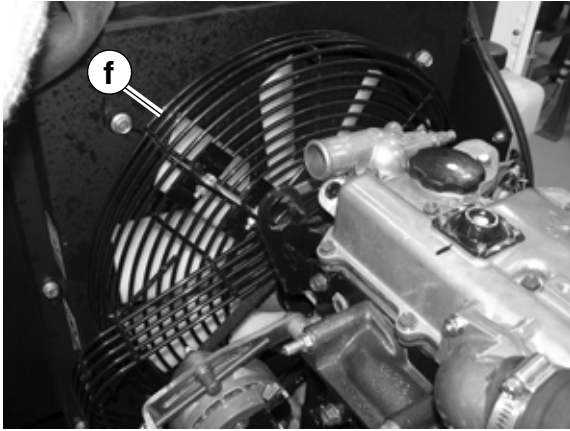
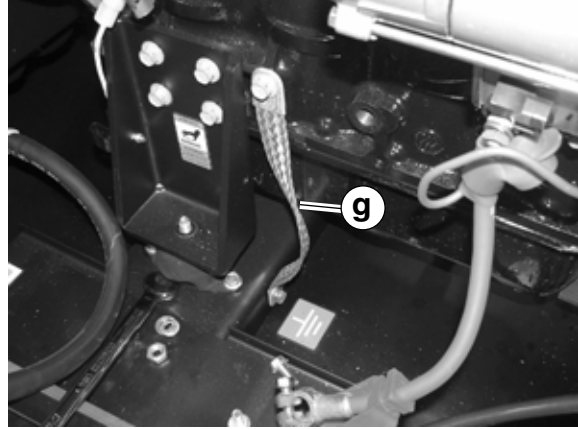
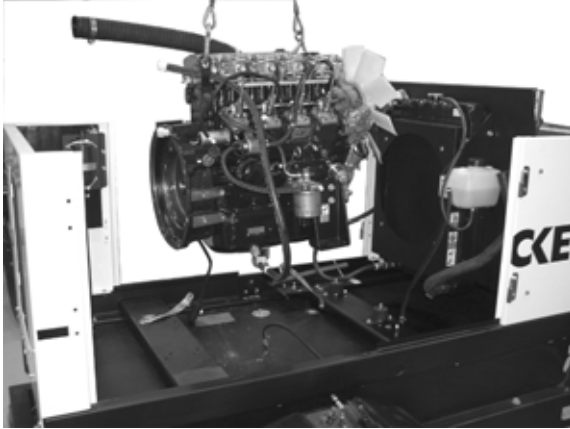

wc_gr003352

9.12 Replacing the Fuel Tank

See Graphic: *wc_gr003350*

This procedure requires a crane or hoist capable of lifting 1900 kgs. (2000 lbs.).

Removal:

- 9.12.1 Disconnect the fuel hoses and the fuel sender wiring.
- 9.12.2 Remove the screws that secure the upper frame assembly **(a)** to the lower frame (skid) **(b)**.
- 9.12.3 Using an appropriate crane or hoist, lift the upper frame assembly off the lower frame assembly.
- 9.12.4 Remove the screws that secure the fuel tank **(c)** to the lower frame assembly.
- 9.12.5 Using an appropriate crane or hoist, lift the fuel tank from the lower frame assembly.

Installation:

- 9.12.6 Using an appropriate crane or hoist, lower the fuel tank into the lower frame assembly.
- 9.12.7 Secure the fuel tank **(c)** to the lower frame assembly.
- 9.12.8 Using an appropriate crane or hoist, lower the upper frame assembly onto the lower frame assembly.
- 9.12.9 Secure the upper frame assembly **(a)** to the lower frame (skid) **(b)**.

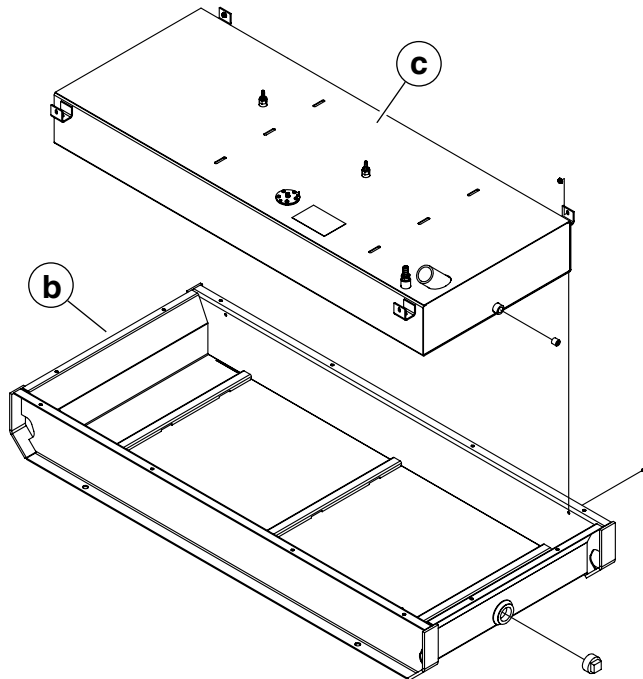
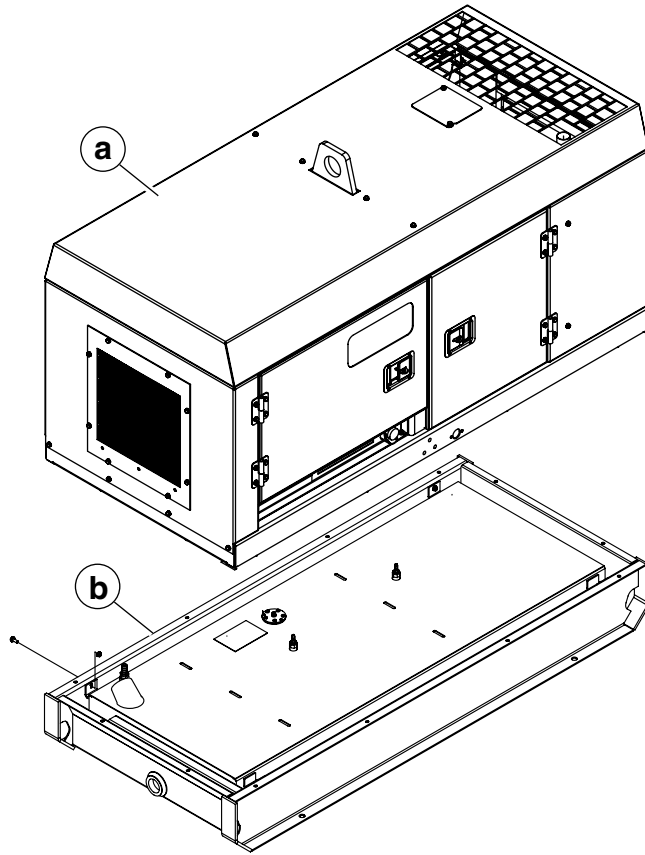

wc_gr003350

9.13 Replacing the Emergency Stop Switch (older)

Turn off the generator before replacing the emergency stop switch.

Removal:

- 9.13.1 Slide the locking tab **(a)** to the unlock position and pull the switch off the pushbutton.
- 9.13.2 Label and disconnect the wiring from the switch.
- 9.13.3 Remove the locking nut **(b)** and washer.
- 9.13.4 Remove the screws **(c)** that secure the pushbutton and remove the pushbutton.

Installation:

- 9.13.5 Slide the pushbutton portion through the door.
Note: *Position the pushbutton with "TOP" marking facing up.*
Secure the pushbutton with screws **(c)**.
- 9.13.6 Attach washer and locking nut **(b)**.
- 9.13.7 Reconnect the wiring.
- 9.13.8 Attach the switch to the pushbutton and slide the locking tab **(a)** to the locked position.

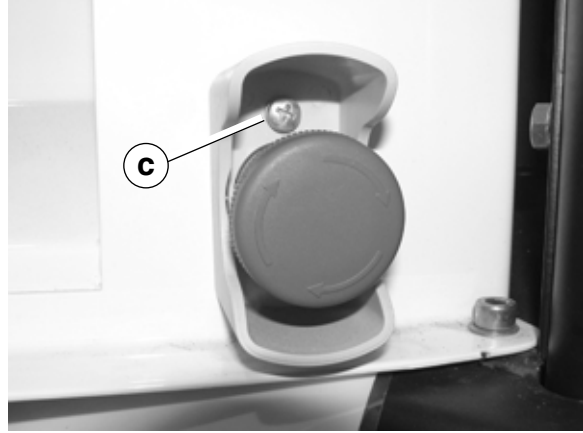
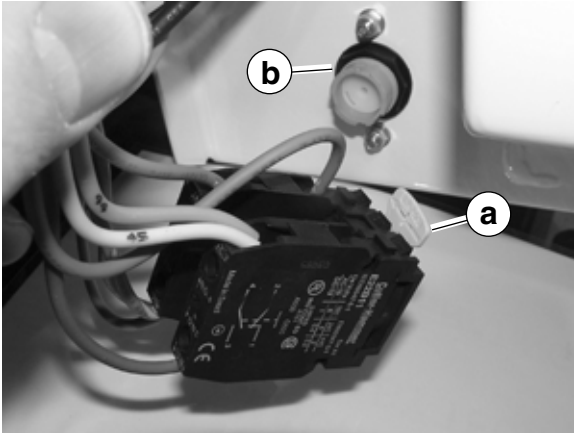

wc_gr003286

9.14 Replacing the Emergency Stop Switch (newer)

See Graphic: *wc_gr003677*

Turn off the generator and disconnect the battery before replacing the emergency stop switch.

Removal:

- 9.14.1 Slide the locking tab **(a)** to the unlock position and pull the contact block **(b)** off the pushbutton **(c)** portion of the switch.
- 9.14.2 Label and disconnect the wiring from the contact block.
- 9.14.3 Remove the locking nut **(d)** and washer **(e)**, and remove the pushbutton portion of the switch.

Installation:

- 9.14.4 Slide the rubber washer **(f)** onto the pushbutton portion of the switch, then insert the pushbutton through the door.
- 9.14.5 Align the washer so that the tab **(g)** is 180° from the notch **(h)** in the door. Slide the washer onto the pushbutton so that the tab of the washer fits in the groove **(i)** of the pushbutton. Secure the pushbutton with the locking nut **(d)**.
- 9.14.6 Reconnect the wiring to the contact block.
- 9.14.7 Attach the contact block to the pushbutton and slide the locking tab **(a)** to the locked position.

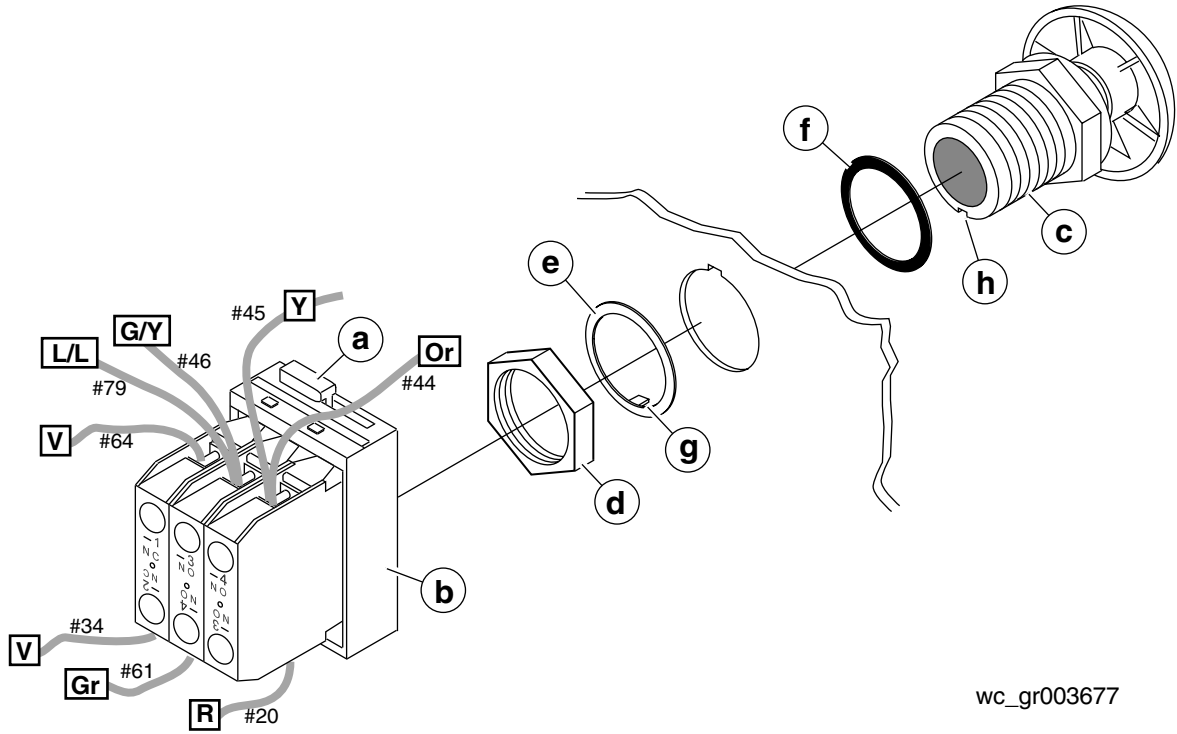

wc_gr003677

9.15 Replacing the Voltage Selector Switch (VSS)

See Graphic: *wc_gr003284*



WARNING

Electric shock hazard. Turn off the generator before replacing the Voltage Selector Switch (VSS).

Removal:

- 9.15.1 Remove the air filter and the cover of the VSS box **(a)**.
- 9.15.2 Label and disconnect all the wires attached to the VSS.
- 9.15.3 Remove the switch handle **(b)** from the VSS.
- 9.15.4 Remove the screws **(c)** that secure the front face of the VSS.
- 9.15.5 Remove the screws that secure the mounting bracket **(d)** to the VSS box and remove the VSS and mounting bracket from the VSS box.
- 9.15.6 Remove the mounting bracket from the VSS **(e)**.

Installation:

- 9.15.7 Attach the mounting bracket **(d)** to the VSS **(e)**.
- 9.15.8 Slide the VSS into the VSS box and secure the face plate **(c)** with the screws.
- 9.15.9 Attach the switch handle **(b)**.
- 9.15.10 Secure the mounting bracket to the VSS box.
- 9.15.11 Connect the wiring to the VSS.
- 9.15.12 Reinstall the cover **(a)** of the VSS box and the air filter.

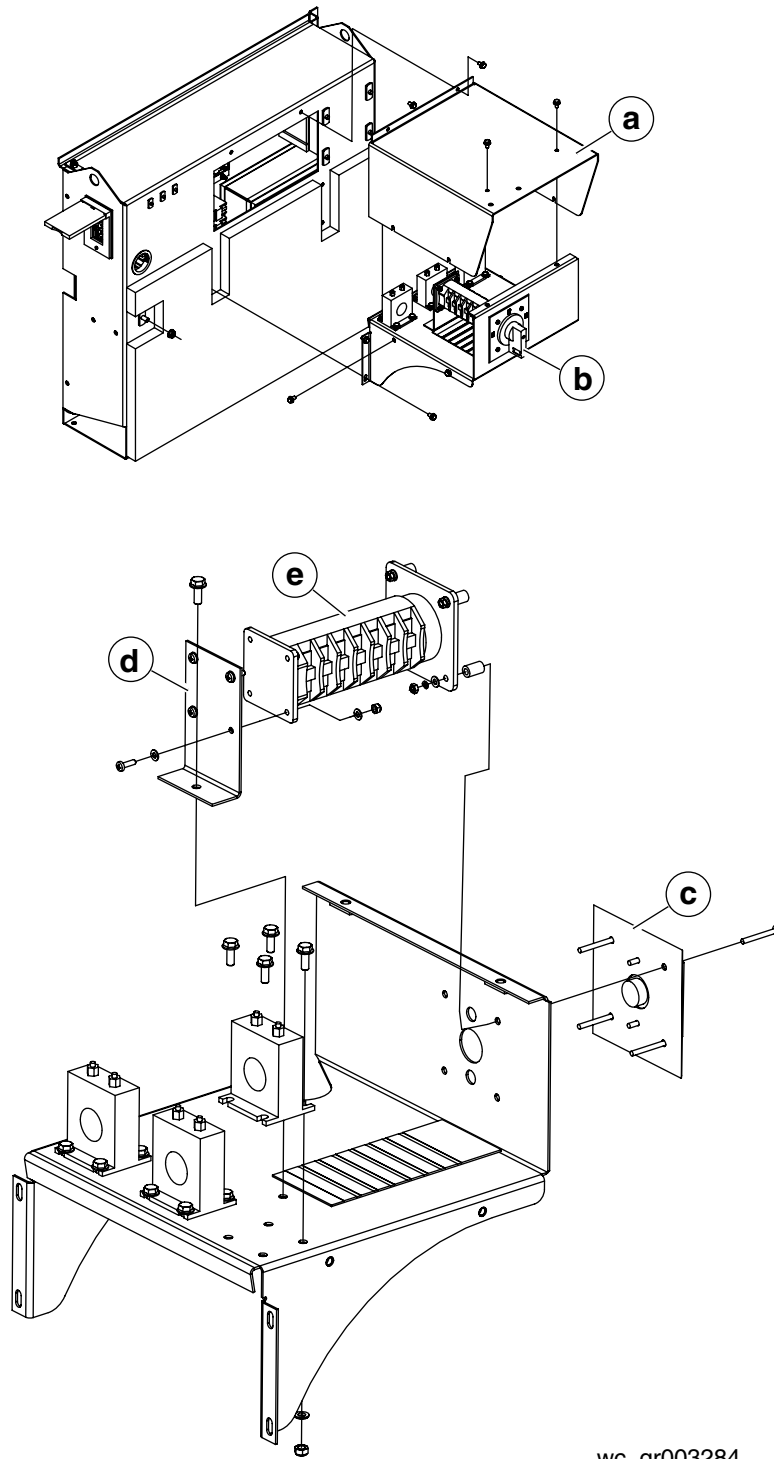

wc_gr003284

G 25 VSS Wiring

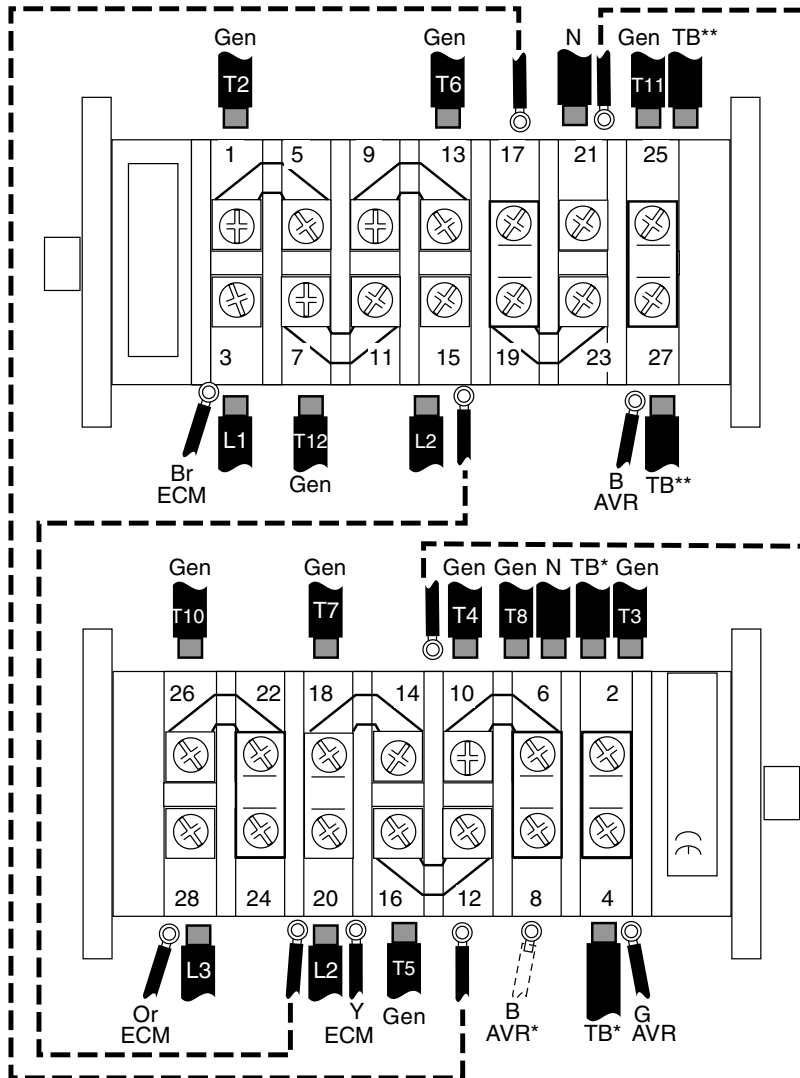

AVR = to Automatic Voltage Regulator
 AVR* = wire location on items:
 0009368 rev 103 & lower,
 0009466 rev 104 & lower,
 0620004 rev 103 & lower
 ECM = to Engine Control Module
 Gen = from generator
 TB* = to terminal block R1 (T7 on older)
 TB** = to terminal block R2 (T9 on older)
 N = to neutral lug L0

wc_gr003698

10. Factory-Installed Options

This machine may be equipped with one or more of the following factory-installed options. To verify if any of these options are installed on your machine, contact the WACKER Corporation at 1-800-770-0957. A nameplate listing the Model Number, Item Number, Revision, and Serial Number is attached to each unit. Please have this information available when contacting WACKER Corporation.

10.1 Block Heater

See Graphic: *wc_gr001709*

The engine block heater option includes a block heater (**a**) with a cord (**b**). The function of the block heater is to heat the engine coolant/engine block to improve cold-weather engine starting. Plug the cord into a 120V power supply.

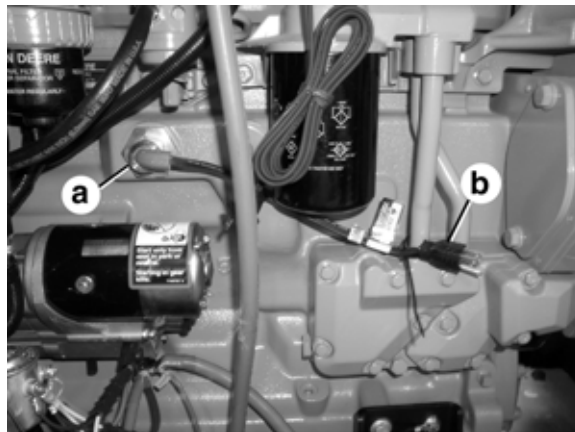

wc_gr001709

10.2 Fuel/Water Separator

See Graphic: *wc_gr001705*

The fuel/water separator separates water from the fuel on models with Isuzu engines. Empty the separator water bowl (**a**) as needed by opening the water bowl drain (**b**). The separator element should be changed each time the fuel filter is changed—approximately every 600 hours of operation.

To change the element:

- 10.2.1 Loosen the element retainer (**d**) and remove the retainer and element (**c**) from the separator head.
- 10.2.2 Unscrew the water bowl from the element.

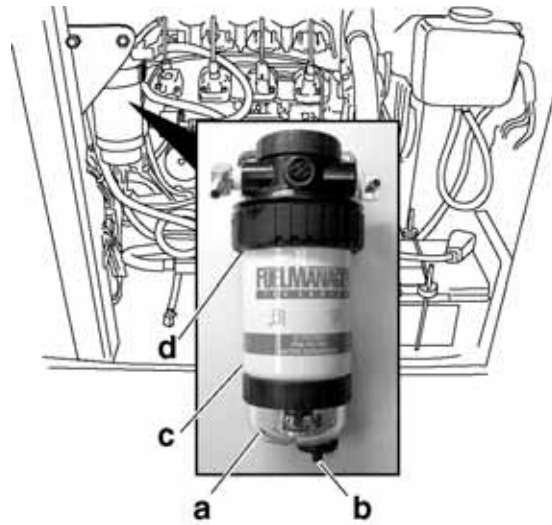

wc_gr001705

10.3 Electronic Governor

See Graphic: *wc_gr001714, wc_gr001715, wc_gr003986, wc_gr001717*

The electronic governor option consists of an electronic module (**a** or **b**) and an electronic actuator (**c** or **d**). The module senses rotation of the flywheel, then sends a signal to the electronic actuator that governs the fuel injection system. The system is designed to precisely regulate engine rpm, and thus frequency, to within approximately 0.25%. See electronic governor manufacturer's literature for detailed information.

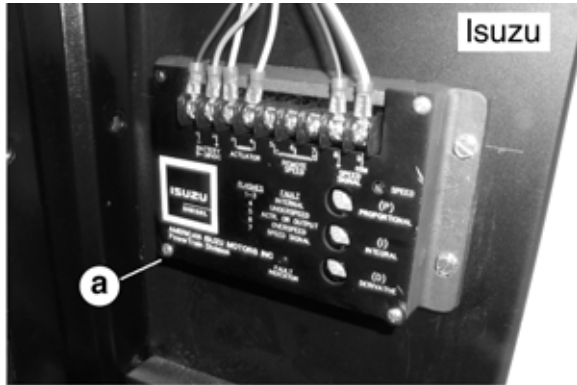

wc_gr001715

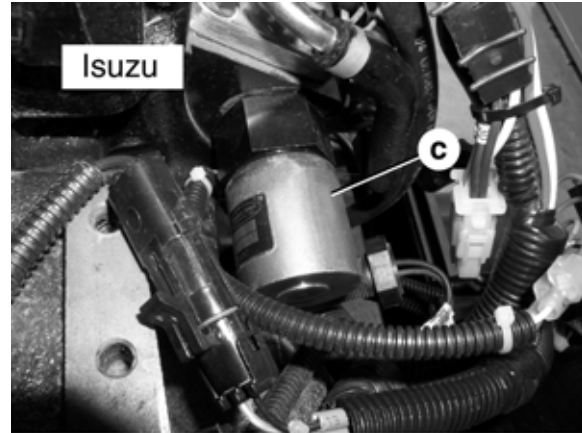

wc_gr001717

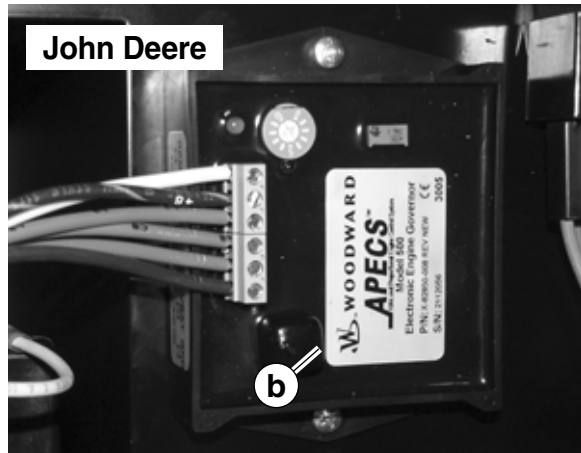

wc_gr003986

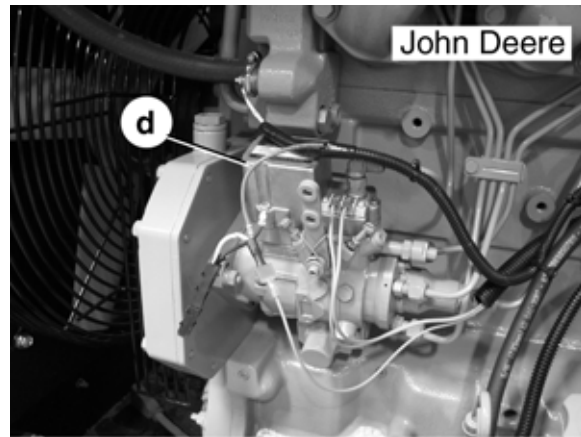

wc_gr001714

10.4 Adjusting the Electronic Governor Module

The electronic ignition module has two adjustable potentiometers (pots)—the speed setpoint pot (**a**) and the gain pot (**b**). The speed setpoint pot is a multi-turn (up to 30) pot used to adjust engine speed. Turning the pot clockwise increases engine speed. Turning it counterclockwise decreases engine speed.

The gain pot controls the Proportional, Integral, and Derivative gain (PID) attributes of the controller. Proportional gain is used to improve response time. Integral gain is used to remove steady-state errors. Derivative gain is used to improve stability. Adjusting the gain pot adjusts all three PID attributes. Turning the gain pot clockwise increases gain. Turning it counterclockwise decreases gain.

The electronic ignition control is tuned at the factory and should not require adjustment. If adjustment is necessary:

- 10.4.1 Adjust speed setpoint until desired speed is achieved. If speed will not settle, turn the gain pot counterclockwise until stable performance results.
- 10.4.2 Once desired speed is established, adjust gain for optimal performance. In general, increase gain until the engine starts to oscillate. Then, reduce gain until stable performance results.

PID settings may be further fine tuned with computer software available from the ignition module manufacturer.

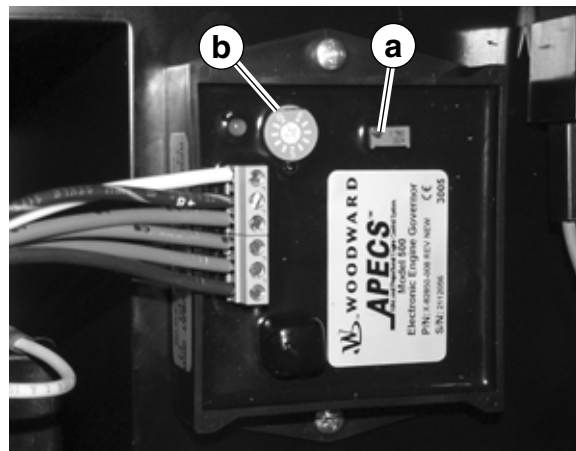

wc_gr003987

10.5 Woodward Electronic Governor LED Status Indicator

The LED on the electronic ignition controller will flash to indicate engine status. These flash codes are listed below. As normal start up procedure, the electronic ignition controller will flash once for one second indicating normal operation. After this initial flash, the LED will flash a fault code if a fault exists or stay on continuously if receiving a good signal from the magnetic pickup.

Flash code	Fault	Corrective action
2	Excessive engine speed.	<ul style="list-style-type: none"> • Check for electrical noise entering controller. • Check wiring and connections. • Check case ground. • Check linkage for binding. • Check tip of speed sensor (magnetic pickup)
3	Low engine speed.	<ul style="list-style-type: none"> • Check linkage and actuator travel.
4	Actuator disconnected, open circuit, or short circuit.	<ul style="list-style-type: none"> • Check actuator wiring and resistance. Actuator resistance should be less than 10 Ohms.
5	Factory settings lost.	<ul style="list-style-type: none"> • Consult Wacker.
6	Speed set pot out of range.	<ul style="list-style-type: none"> • Consult Wacker.
7	Gain set pot out of range.	<ul style="list-style-type: none"> • Consult Wacker.
8	Controller unit failed.	<ul style="list-style-type: none"> • Check for electrical noise entering controller. • Check wiring and connections. • Consult Wacker.

10.6 Troubleshooting the Electronic Governor

Troubleshooting the electronic governor is limited to:

- Checking input voltage from the battery
- Checking input voltage from the magnetic pickup
- Checking the resistance of actuator coil
- Checking continuity of the wiring between the components

To check the input voltage:

- 10.6.1 Place the generator START switch in the START/RUN position.
- 10.6.2 Check voltage between B+ and B- terminals of the control unit.
 - If less than 9.8VDC is measured, check battery charge. Also check the wiring between the control unit and the ECM.
 - If more than 9.8–30VDC is measured, the input voltage is OK.

To check the input voltage from the magnetic pickup:

- 10.6.3 Disconnect the magnetic pickup. Attach a voltmeter to the magnetic pickup leads.
- 10.6.4 Place the START switch in the START/RUN position so that the engine cranks.
- 10.6.5 Measure the voltage produced by the magnetic pickup.
 - If less than 2.5VAC is measured, the magnetic pickup has failed or is installed incorrectly.
 - If more than 2.5VAC is measured, the magnetic pickup is OK.

To check the resistance of the actuator coil:

- 10.6.6 Disconnect the wiring to the actuator.
- 10.6.7 Measure the resistance across the two terminals or leads of the actuator. Actuator coil resistance should be:
2.05±0.5 Ohms on Deere engines;
4.5±0.3 Ohms on Isuzu engines.
 - If the above resistance is measured, the actuator coil is OK.
 - If the actuator coil is open or shorted, the actuator has failed.

10.7 Schematic—Isuzu Engine with Electronic Governor

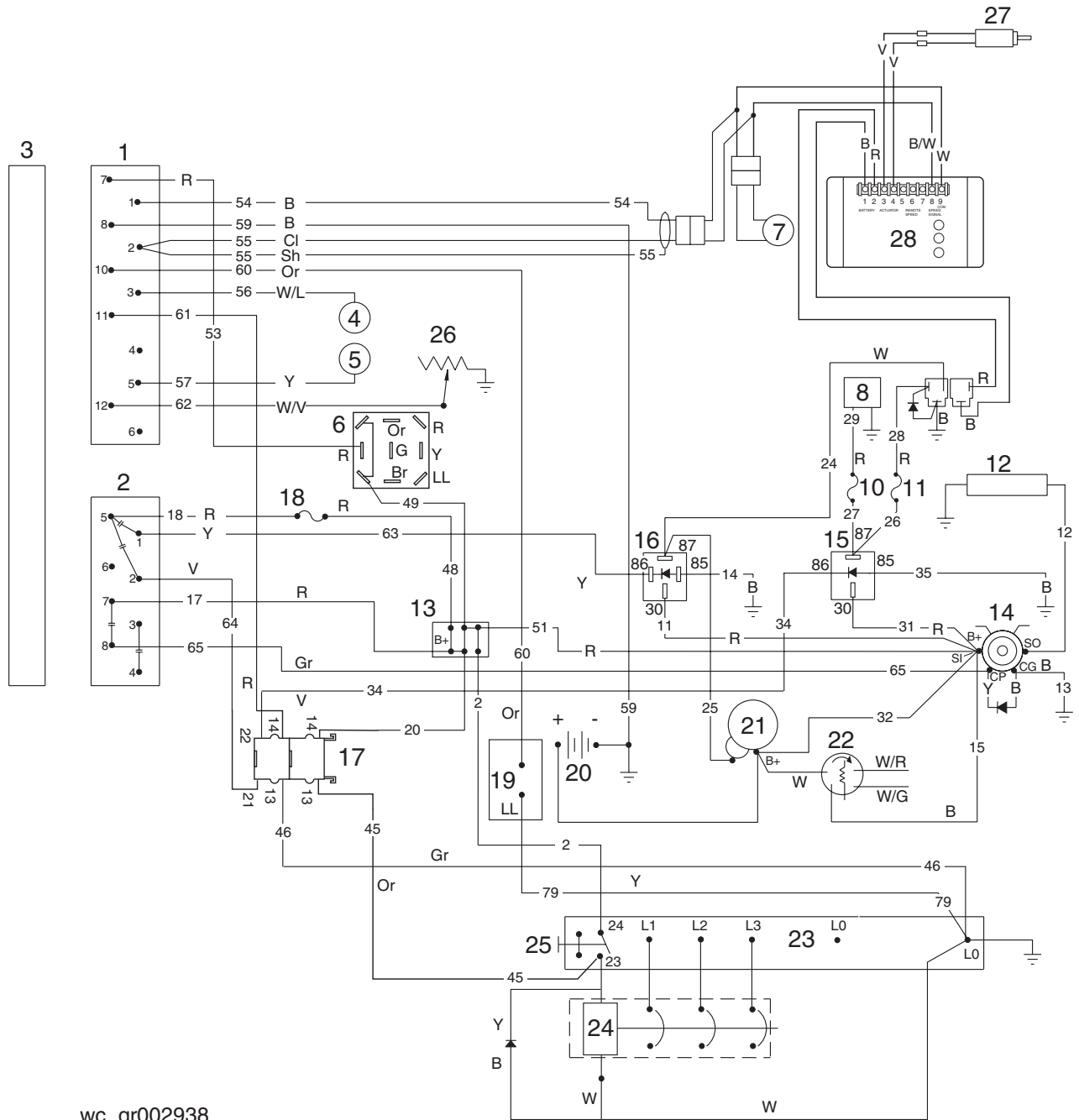

wc_gr002938

10.8 Components—Isuzu Engine with Electronic Governor

Ref.	Component	Ref.	Component
1	Plug 1 - engine sender inputs	15	Fuel relay
2	Plug 2 - engine start outputs	16	Starter relay
3	Engine control module	17	Emergency stop switch
4	Oil pressure sender	18	10A fuse #1
5	Water temperature sender	19	Remote start terminals
6	Remote Start - Off - Start/Run switch	20	Battery
7	Magnetic pickup	21	Starter motor
8	Fuel pump	22	Alternator
9	---	23	Mechanical lugs
10	10A fuse #2	24	Main circuit breaker - shunt trip
11	10A fuse #3	25	Lug door interlock switch
12	Glow plugs	26	Fuel level sender
13	B+ terminal block	27	Actuator
14	Glow plug relay	28	Electronic governor

10.9 Schematic—John Deere Engine with Electronic Governor

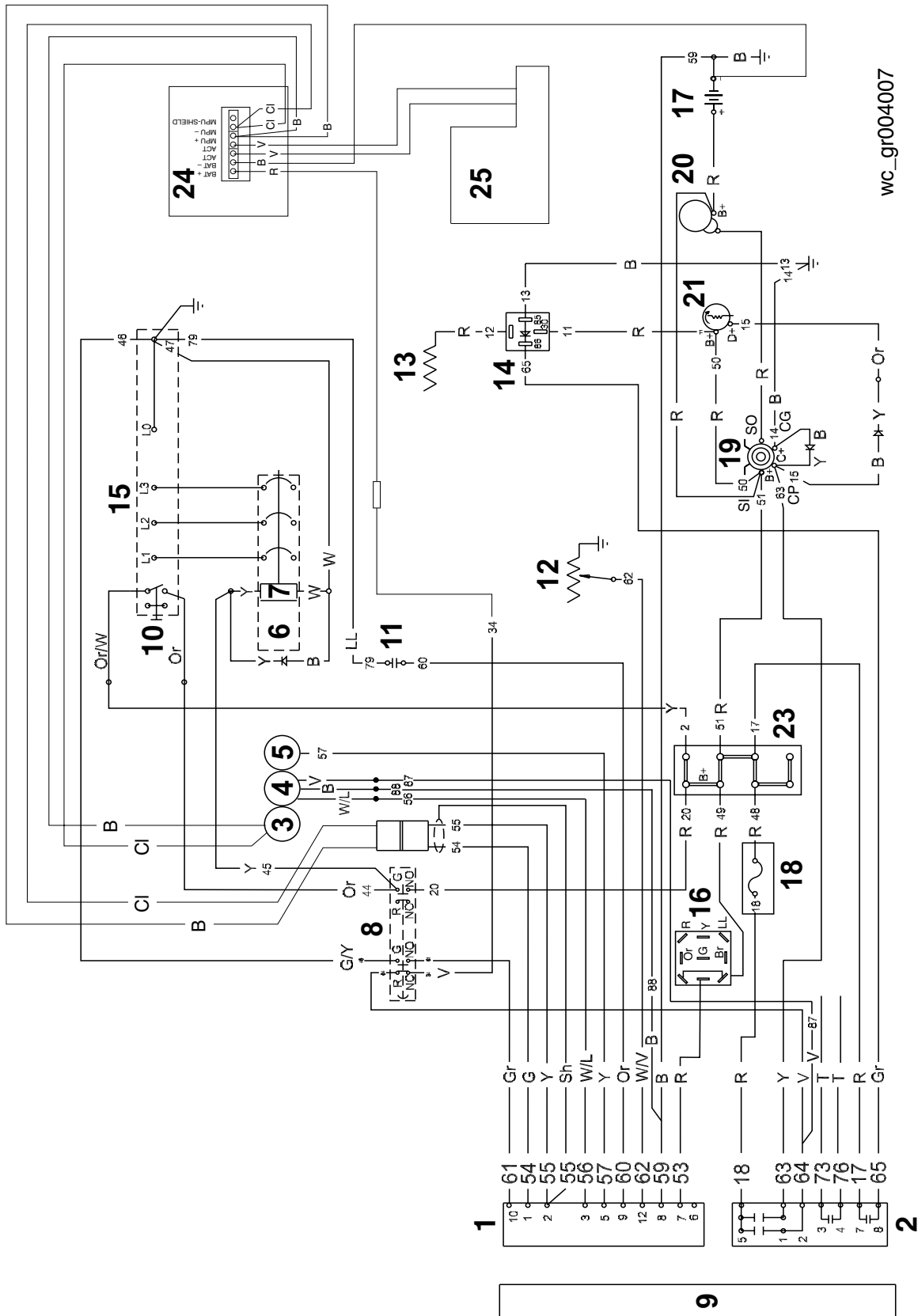

wc_gr004007

10.10 Components—John Deere Engine with Electronic Governor

Ref.	Description	Ref.	Description
1	Plug 1 - engine sender inputs	14	Slave preheat relay
2	Plug 2 - engine start outputs	15	Mechanical lugs
3	Magnetic pickup	16	Remote Start - Off - Start/Run switch
4	Oil pressure sender	17	Battery
5	Coolant temperature sender	18	10A fuse
6	Main circuit breaker	19	Starter relay
7	Shunt trip, main breaker	20	Starter
8	Emergency Stop switch	21	Alternator
9	Engine control module (ECM)	22	---
10	Lug door switch	23	Terminal Block
11	Remote start terminals	24	Electronic governor
12	Fuel level sender	25-	Actuator
13	Intake heater	26	---

10.11 LCD Strip Heater

See Graphic: *wc_gr001723, wc_gr001724*

The LCD strip heater option includes a thermostat module **(a)** and a clear heater strip that is bonded to the LCD **(b)** of the ECM. The purpose of the strip heater is to prevent the LCD from being damaged by extremely cold temperatures. The resistance of the coiled element of the heater is sensed by the thermostat. The resistance of the element changes with temperature. At approximately -30°C , the resistance value triggers the thermostat to send power to the element. The LED **(c)** of the thermostat module flashes during operation.

It is important to note that the LCD strip heater is always on and thus draws power (a very small amount) from the battery even when the unit is not running. If the battery should fail, the heater will also fail. Be sure to keep the battery charged when the generator is not in use.

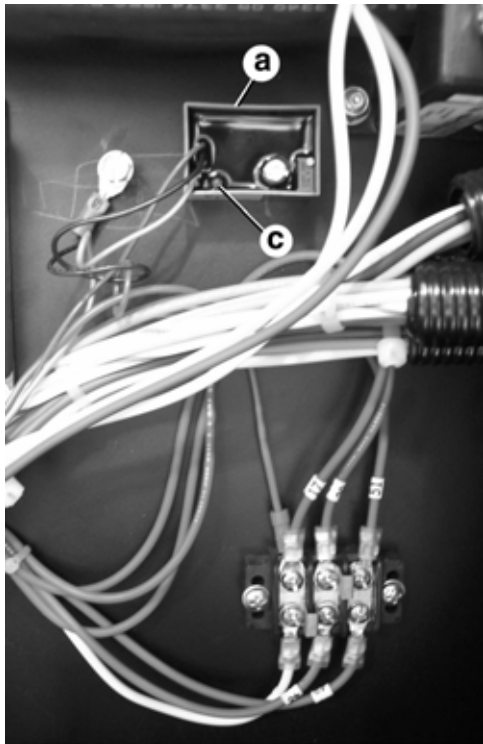

wc_gr001723

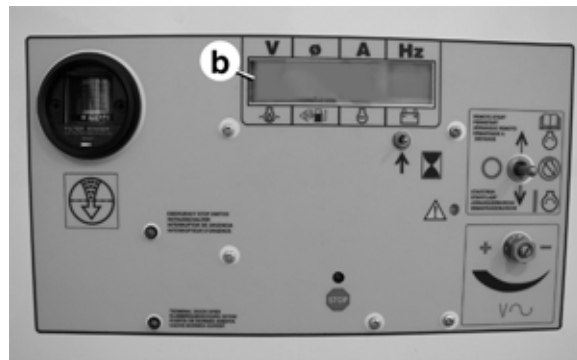

wc_gr001724

10.12 Low Coolant Shutdown

See Graphic: *wc_gr001708*

The low-coolant shutdown system consists of an electronic sensor that monitors coolant level. The sensor **(a)** is mounted to the radiator and wired into the ECM. The sensor probe **(b)** is submerged in radiator coolant. If the probe senses no coolant, it sends a signal to the ECM. The ECM program includes a 10-second timer to protect from nuisance shutdowns. If after the ten seconds coolant levels are still sensed as being low, the ECM shuts down the engine. The ECM will then display the “FAULT LOW WATER LEVEL”. Allow the engine to cool before adding additional coolant.



NEVER remove the radiator cap while the engine is hot! Pressurized coolant can cause serious burns.

If it is necessary to open the radiator, only do so with the engine off, and only when coolant is cool enough to touch with bare hands. Slowly loosen the radiator cap to relieve pressure first, before removing it completely.

Note: *The sensor may be disabled by unplugging the wire harness. This action will not shut down the machine.*

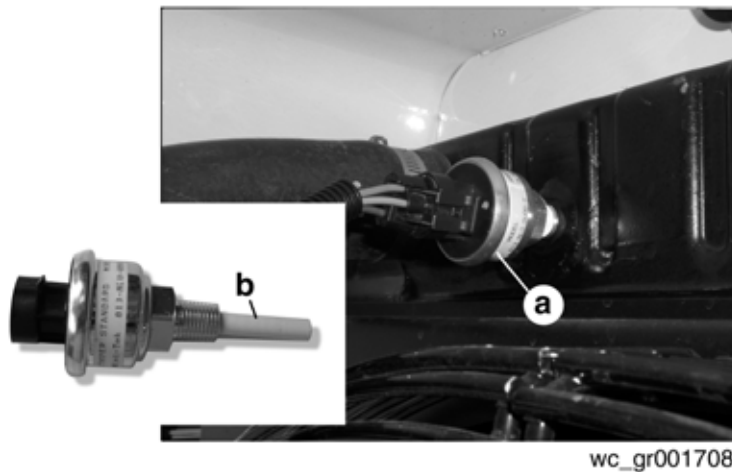

10.13 Lube Level Maintainer

See Graphic: *wc_gr001711, wc_gr001712, wc_gr001713*

The lube level maintainer system protects the engine from low oil levels by providing an additional 6-quart oil reservoir. Oil from the reservoir is gravity-fed from the oil reservoir **(a)** through the control valve **(b)** and into the engine oil pan as needed. The valve includes a sightglass **(c)** through which the oil level can be seen. This oil level is the same as that measured by the engine dipstick. A float inside the valve detects low oil levels and opens the valve to supply the needed oil. The system is wired to the ECM and includes a low oil shutdown in case the oil in the reservoir is depleted. If the engine shuts down due to low oil, the ECM will display “FAULT LOW OIL LEVEL”. Fill the engine and the additional oil reservoir with oil before placing the generator back into service.

Note: *On machines with the Isuzu engine, the reservoir is mounted to the enclosure door.*

NOTICE: To prevent overfilling the engine with oil, place the shutoff valve **(d)** in the closed position when moving or towing the generator. Once the generator is in position, open the valve.

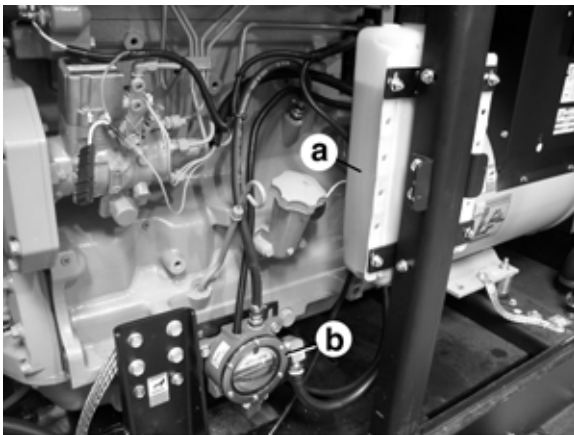

wc_gr001711

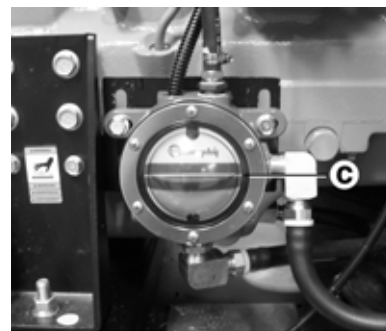

wc_gr001712



wc_gr001713

10.14 Temperature-Activated Shutters

See Graphic: *wc_gr001706, wc_gr001707*

The shutters (a) are mounted to the top of the generator enclosure. The shutters are designed to keep the engine compartment warm, thus increasing engine temperature during cold weather operation. The shutters are activated through a wax-pellet actuator (b) that is connected to the generator's cooling system. As radiator coolant warms, the wax-pellet actuator engages a linkage (c) that opens the shutters. As the coolant cools, the shutters close.



wc_gr001707

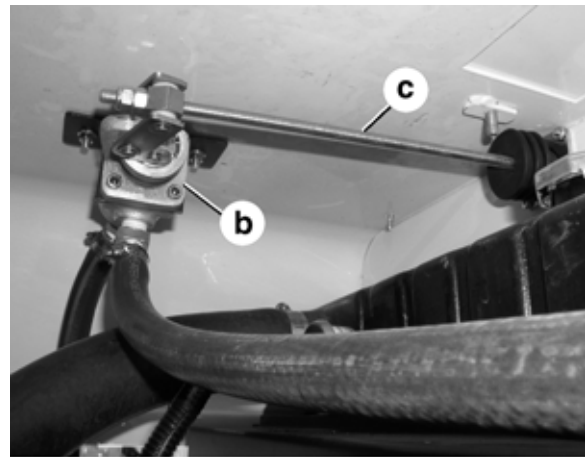

wc_gr001706

10.15 Schematic

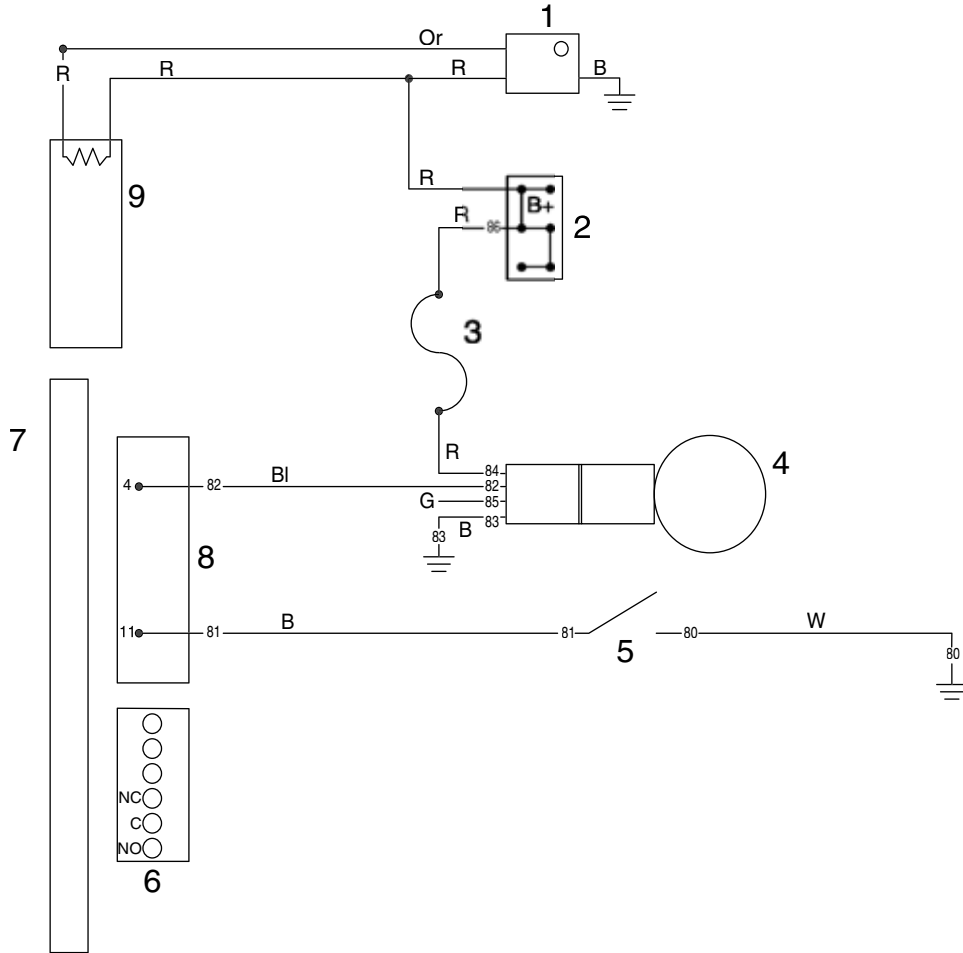

wc_gr003174

Wire Colors							
B	Black	R	Red	Y	Yellow	Or	Orange
G	Green	T	Tan	Br	Brown	Pr	Purple
L	Blue	V	Violet	Cl	Clear	Sh	Shield
P	Pink	W	White	Gr	Gray	LL	Light blue

10.16 Components

See Graphic: wc_gr003174

Ref	Description	Ref	Description
1	Thermostat module	6	Auxiliary relay terminals
2	Terminal block	7	Plug 1, engine sensor inputs
3	1 Amp fuse	8	Electronic control board
4	Water level sensor	9	LCD heater
5	Lube level maintainer low level switch		

11. Technical Data

11.1 Engine Data

Item Number:	G 85 0009369 0009459 0620003 rev 114 & lower		G 85 0620003 rev 115 & above	
Engine				
Engine make / type	John Deere / 4.5L			
Model	4045TF275			
Number of cylinders	4			
Displacement	l (in ³)	4.5 (274.6)		
Engine speed	rpm	1800		
Power @ 1800 rpm	kW/Hp	84.2/113		
Coolant capacity	l (qts.)	22.7 (24)		
Oil capacity	l (qts.)	15 (15.9)		
Battery	Volts/ CCA	12/720	12/1000	
Fuel type	Diesel			
Fuel tank capacity	l (gal.)	337 (89)		
Fuel consumption, continuous load	l/hr (gal./ hr)	21.2 (5.6)		
Running time, continuous load	Hours	16		

11.2 Generator Data

Item Number:	G 50 0009366 0009467 0620001 Rev. 112 & lower	G 70 0009367 0009468 0620002 Rev. 113 & lower
Engine		
Engine make / type	John Deere / 4.5L	
Model	4045DF270	4045TF270
Number of cylinders	4	
Displacement	l (in ³) 4.5 (274.6)	
Engine speed	rpm 1800	
Power @ 1800 rpm	kW/Hp 50/67	74.5/100
Coolant capacity	l (qts.) 22.7 (24)	
Oil capacity	l (qts.) 15 (15.9)	
Battery	Volts/CCa 12/720	
Fuel type	Diesel	
Fuel tank capacity	l (gal.) 337 (89)	
Fuel consumption, continuous load	l/hr (gal./ hr) 12.5 (3.3)	17.4 (4.6)
Running time, continuous load	Hours 27	19.3

Item Number:	G 50 0620001 Rev. 113 & above	G 70 0620002 Rev. 114 & above
Engine		
Engine make / type	John Deere / 4.5L	
Model	4045DF270	4045TF270
Number of cylinders	4	
Displacement	l (in ³) 4.5 (274.6)	
Engine speed	rpm 1800	
Power @ 1800 rpm	kW/Hp 50/67	74.5/100
Coolant capacity	l (qts.) 22.7 (24)	
Oil capacity	l (qts.) 15 (15.9)	
Battery	Volts/CCa 12/1000	
Fuel type	Diesel	
Fuel tank capacity	l (gal.) 337 (89)	
Fuel consumption, continuous load	l/hr (gal./hr) 12.5 (3.3)	17.4 (4.6)
Running time, continuous load	Hours 27	19.3

11.3 Trailer and Skid Data

Item Number:		G 85 0009369	G 85 0009459 0620003
Trailer and Skid			
Dry weight of skid	kg (lbs.)	1580 (3484)	1621 (3574)
Operating weight of skid	kg (lbs.)	1868 (4120)	1909 (4210)
Trailer weight	kg (lbs.)		
	Single axle		
	Tandem axle	499 (1100)	
GVWR	kg (lbs.)		
	Single axle		
	Tandem axle	2722 (6000)	
Surge brakes	Fluid type	DOT3	
Tires	size	ST225/75D-15D	

11.4 Dimensions

mm (inches)

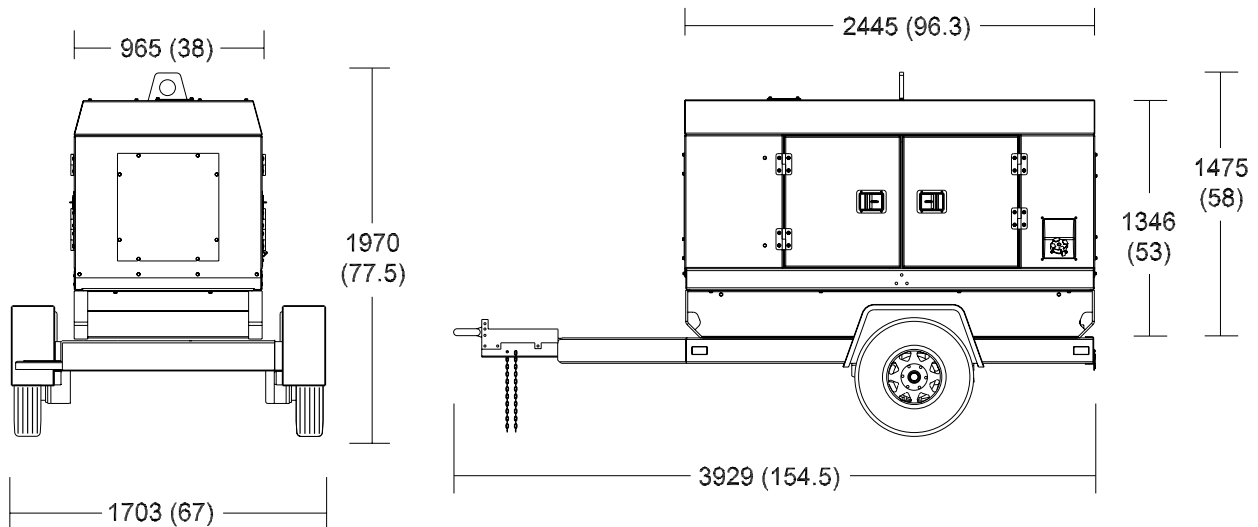

wc_gr002606

Engine Wiring Components—*John Deere with ECU*

Ref.	Description	Ref.	Description
1	Plug 1 — engine sender inputs	14	Battery
2	Plug 2 — engine start/run outputs	15	ECM 10A fuse
3	Main circuit breaker (3-phase lugs)	16	Starter relay
4	Shunt trip coil	17	Starter
5	Emergency stop switch	18	Alternator
6	Engine Control Module (ECM)	19	B+ Terminal block
7	Safety interlock switch	20	System 10A fuse
8	Remote start terminals	21	System 30A fuse
9	Fuel level sender	22	Harness connector
10	Intake heater	23	CAN bus connector
11	Slave preheat relay	24	Diagnostic connector
12	Mechanical lugs (3 phase)	25	ECU harness connector
13	Start switch	26	Hour meter switch

ECM Plug 1 Wires			ECM Plug 2 Wires		
Pin	Wire	Description	Pin	Wire	Description
10	Gr/61	Emergency stop	5	R/18	Battery + (for relays)
3	W/L/56	Oil pressure sender	1	Y/63	Crank (12V output)
9	Or/60	Remote start	2	V/64	Run/Fuel (12V output)
12	W/V/62	Fuel level	3	73	Remote annunciator (NA)
8	B/59	Battery –	4	75	Remote annunciator (NA)
7	R/53	Battery + (for ECM board)	-	-	---

Wire Colors							
B	Black	R	Red	Y	Yellow	Or	Orange
G	Green	T	Tan	Br	Brown	Pr	Purple
L	Blue	V	Violet	Cl	Clear	Sh	Shield
P	Pink	W	White	Gr	Gray	LL	Light blue

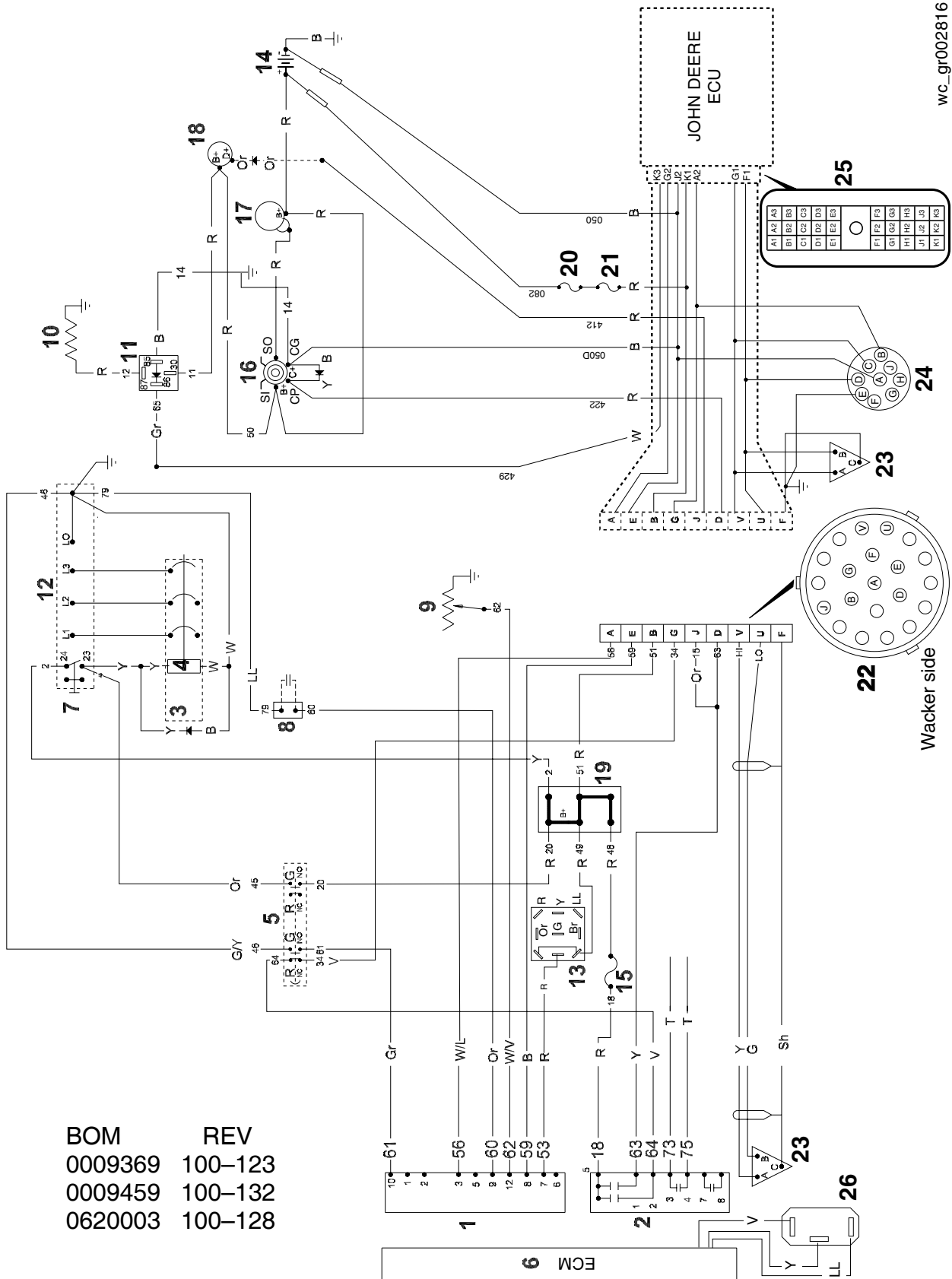

wc_gr002816

BOM	REV
0009369	100-123
0009459	100-132
0620003	100-128

Engine Wiring Components—*John Deere with ECU*

Ref.	Description	Ref.	Description
1	Plug 1 — engine sender inputs	14	Battery
2	Plug 2 — engine start/run outputs	15	ECM 10A fuse
3	Main circuit breaker (3-phase lugs)	16	Starter relay
4	Shunt trip coil	17	Starter
5	Emergency stop switch	18	Alternator
6	Engine Control Module (ECM)	19	B+ Terminal block
7	Safety interlock switch	20	System 10A fuse
8	Remote start terminals	21	System 30A fuse
9	Fuel level sender	22	Harness connector
10	Intake heater	23	CAN bus connector
11	Slave preheat relay	24	Diagnostic connector
12	Mechanical lugs (3 phase)	25	ECU harness connector
13	Start switch	26	Hour meter switch

ECM Plug 1 Wires			ECM Plug 2 Wires		
Pin	Wire	Description	Pin	Wire	Description
10	Gr/61	Emergency stop	5	R/18	Battery + (for relays)
3	W/L/56	Oil pressure sender	1	Y/63	Crank (12V output)
9	Or/60	Remote start	2	V/64	Run/Fuel (12V output)
12	W/V/62	Fuel level	3	73	Remote annunciator (NA)
8	B/59	Battery –	4	75	Remote annunciator (NA)
7	R/53	Battery + (for ECM board)	-	-	---

Wire Colors							
B	Black	R	Red	Y	Yellow	Or	Orange
G	Green	T	Tan	Br	Brown	Pr	Purple
L	Blue	V	Violet	Cl	Clear	Sh	Shield
P	Pink	W	White	Gr	Gray	LL	Light blue

11.7 ECU Harness Connector

See Graphic: wc_gr002817

Ref.	Wire Color/#	Destination	Ref.	Wire Color/#	Destination
A1	---	---	F1	Green/905	CAN bus
A2	Red/012C	Harness Connector (HC) terminal G	F2	---	---
A3	Orange/493	Fuel control solenoid	F3	Violet/467	Oil pressure sensor
B1	Brown/461	Colant temp sensor	G1	Yellow/904	CAN bus
B2	Violet/447	Engine crank sensor	G2	W/L / 474	ECM
B3	Gray/918	HC terminal N (N/A)	G3	Orange/473	HC terminal H (N/A)
C1	Violet/947	HC terminal R (N/A)	H1	---	---
C2	---	---	H2	---	---
C3	Gray/428	Fuel temp sensor	H3	---	---
D1	Orange/463	Manifold Air Temp (MAT) sensor	J1	Gray/418	N/A
D2	Gray/448	Engine crank sensor	J2	Black/050C	Ground
D3	Yellow/914C	Sensor return	J3	---	---
E1	---	---	K1	Red/022	10A fuse
E2	Brown/911C	Sensor excitation 5V	K2	Brown/491	Fuel control solenoid
E3	White/439	HC terminal K (N/A)	K3	White/429	Air heater relay

11.8 Generator Wiring Diagram

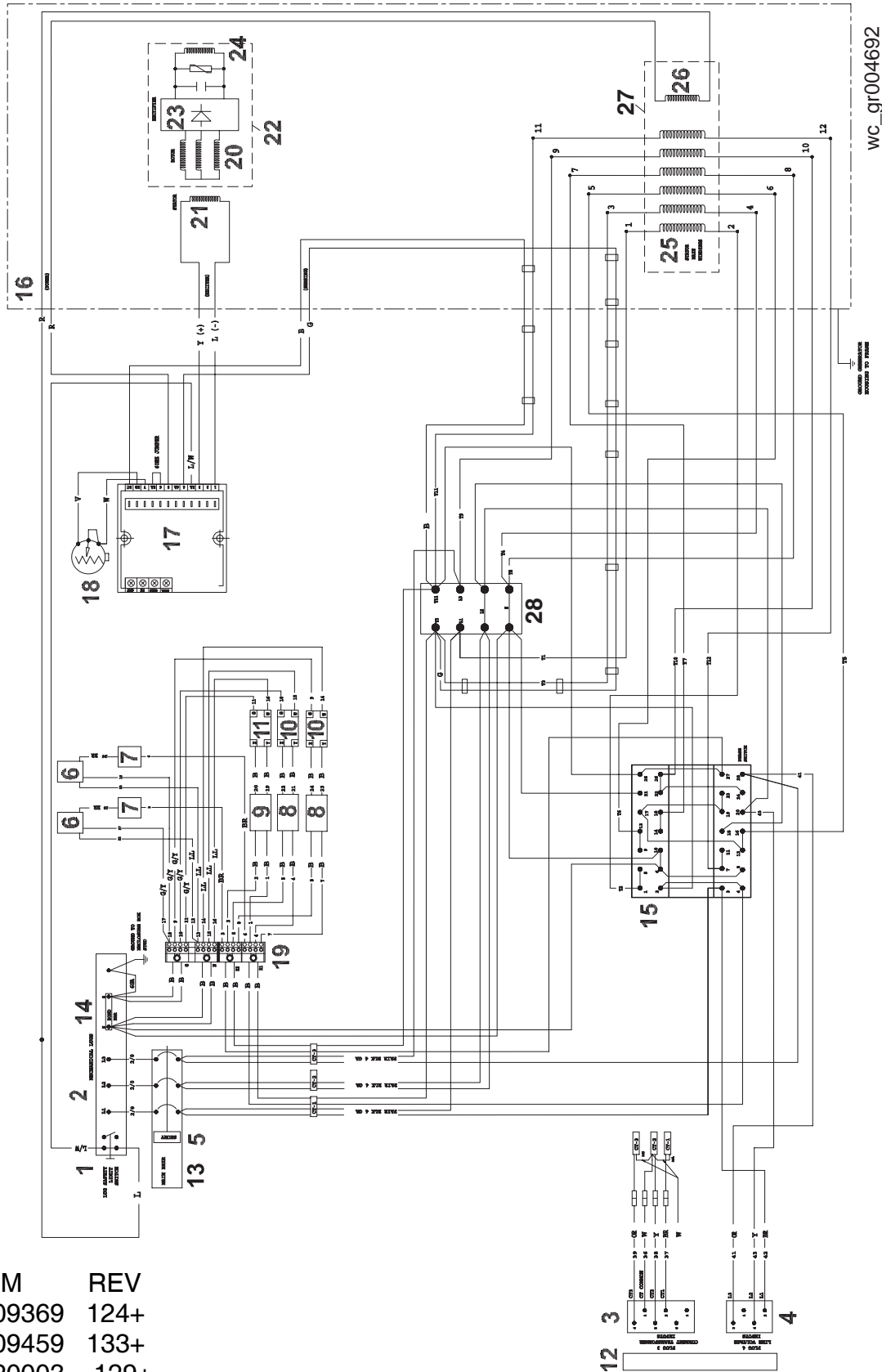

WC_gr004692

BOM	REV
0009369	124+
0009459	133+
0620003	129+

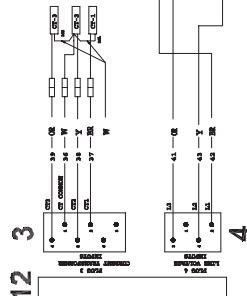

See Graphic: wc_gr004692

Ref.	Description	Ref.	Description
1	Lug door (safety interlock) switch	15	Voltage Selector Switch (VSS)
2	Mechanical lugs	16	Generator
3	Plug 3 - current transformer inputs	17	Automatic Voltage Regulator (AVR)
4	Plug 4 - line voltage inputs	18	Voltage adjustment rheostat
5	Shunt	19	Terminal block
6	120V 20A GFI receptacle	20	Exciter rotor windings
7	120V breaker	21	Exciter stator winding
8	240V 50A breaker	22	Rotor
9	240V 30A breaker	23	Rectifier (diodes)
10	240V 50A receptacle	24	Main rotor winding
11	240V 30A receptacle	25	Main stator windings
12	Engine Control Module (ECM)	26	Auxiliary winding
13	Bus bar	27	Stator
14	Main breaker	28	Terminal strip

ECM Plug 3 Wires			ECM Plug 4 Wires		
Pin	Wire	Description	Pin	Wire	Description
4	Or 39	Ammeter line input CT3	3	Or 41	Voltage line input L3 at volt selector #28
1	W 36	Ammeter input CT common	4	Y 43	Voltage line input L2 at volt selector #20
5	Y 38	Ammeter line input CT2	2	Br 42	Voltage line input L1 at volt selector #3
2	Br 37	Ammeter line input CT1	-	-	---

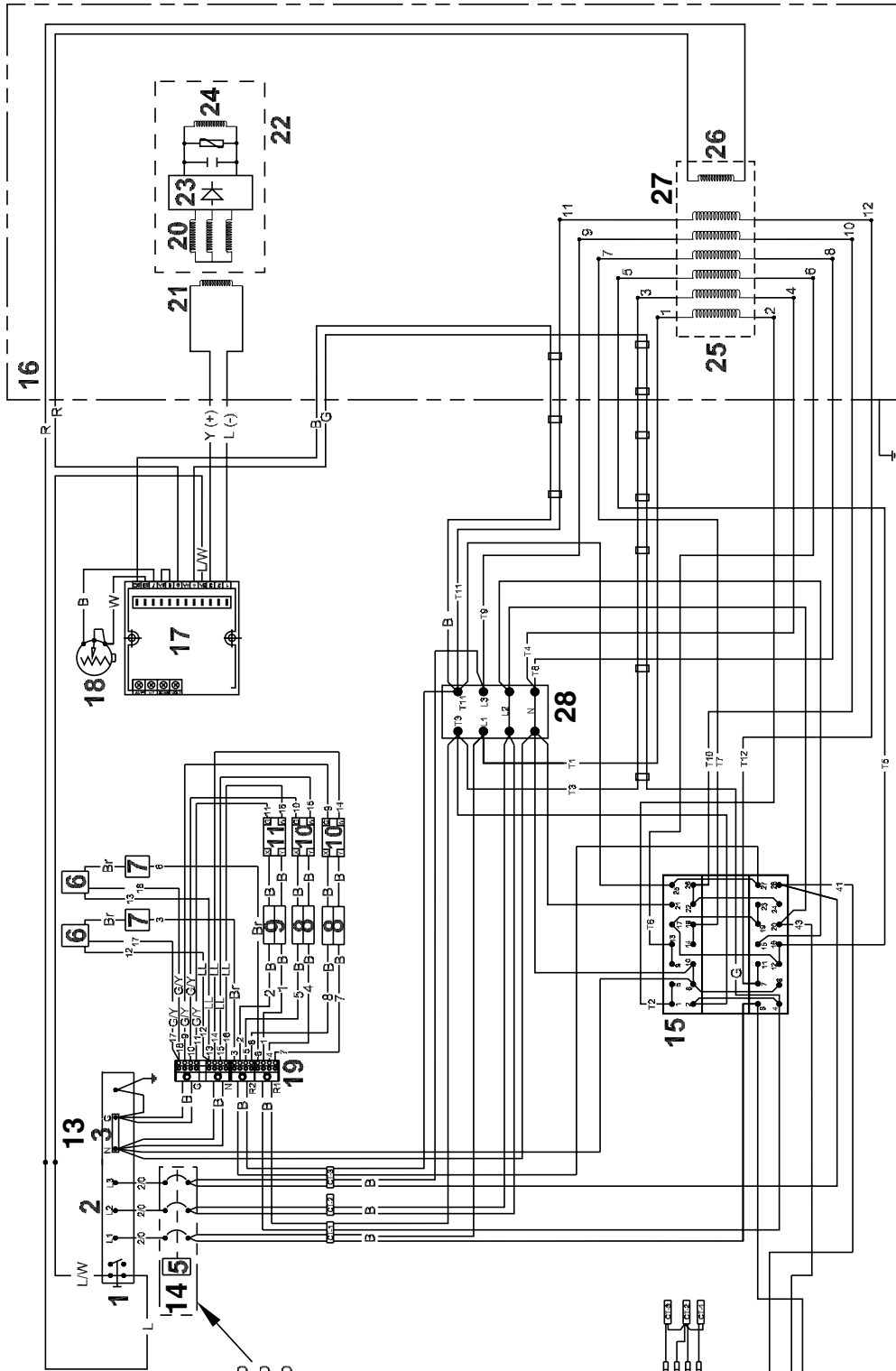

wc_gr003296

BOM	REV
0009369	100-123
0009459	100-132
0620003	100-128

- G 50 - 175 Amp
- G 70 - 225 Amp
- G 85 - 250 Amp

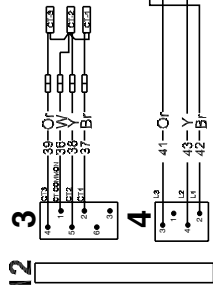

See Graphic: wc_gr003296

Ref.	Description	Ref.	Description
1	Lug door (safety interlock) switch	15	Voltage Selector Switch (VSS)
2	Mechanical lugs	16	Generator
3	Plug 3 - current transformer inputs	17	Automatic Voltage Regulator (AVR)
4	Plug 4 - line voltage inputs	18	Voltage adjustment rheostat
5	Shunt	19	Terminal block
6	120V 20A GFI receptacle	20	Exciter rotor windings
7	120V breaker	21	Exciter stator winding
8	240V 50A breaker	22	Rotor
9	240V 30A breaker	23	Rectifier (diodes)
10	240V 50A receptacle	24	Main rotor winding
11	240V 30A receptacle	25	Main stator windings
12	Engine Control Module (ECM)	26	Auxiliary winding
13	Bus bar	27	Stator
14	Main breaker	28	Terminal strip

ECM Plug 3 Wires			ECM Plug 4 Wires		
Pin	Wire	Description	Pin	Wire	Description
4	Or 39	Ammeter line input CT3	3	Or 41	Voltage line input L3 at volt selector #28
1	W 36	Ammeter input CT common	4	Y 43	Voltage line input L2 at volt selector #20
5	Y 38	Ammeter line input CT2	2	Br 42	Voltage line input L1 at volt selector #3
2	Br 37	Ammeter line input CT1	-	-	---

Threadlockers and Sealants

Threadlockers and Sealants

Threadlocking adhesives and sealants are specified throughout this manual by a notation of “S” plus a number (S#) and should be used where indicated. Threadlocking compounds normally break down at temperatures above 175°C (350°F). If a screw or bolt is hard to remove, heat it using a small propane torch to break down the sealant. When applying sealants, follow instructions on container. The sealants listed are recommended for use on Wacker equipment.

TYPE () = Europe	COLOR	USAGE	PART NO. – SIZE
Loctite 222 Hernon 420 Omnifit 1150 (50M)	Purple	Low strength, for locking threads smaller than 6 mm (1/4”). Hand tool removable. Temp. range: -54 to 149°C (-65 to 300°F)	73287 - 10 ml
Loctite 243 Hernon 423 Omnifit 1350 (100M)	Blue	Medium strength, for locking threads larger than 6 mm (1/4”). Hand tool removable. Temp. range: -54 to 149°C (-65 to 300°F)	29311 - .5 ml 17380 - 50 ml
Loctite 271/277 Hernon 427 Omnifit 1550 (220M)	Red	High strength, for all threads up to 25 mm (1”). Heat parts before disassembly. Temp. range: -54 to 149°C (-65 to 300°F)	29312 - .5 ml 26685 - 10 ml 73285 - 50 ml
Loctite 290 Hernon 431 Omnifit 1710 (230LL)	Green	Medium to high strength, for locking preassembled threads and for sealing weld porosity (wicking). Gaps up to 0.13 mm (0.005”) Temp. range: -54 to 149°C (-65 to 300°F)	28824 - .5 ml 25316 - 10 ml
Loctite 609 Hernon 822 Omnifit 1730 (230L)	Green	Medium strength retaining compound for slip or press fit of shafts, bearings, gears, pulleys, etc. Gaps up to 0.13 mm (0.005”) Temp. range: -54 to 149°C (-65 to 300°F)	29314 - .5 ml
Loctite 545 Hernon 947 Omnifit 1150 (50M)	Brown	Hydraulic sealant Temp. range: -54 to 149°C (-65 to 300°F)	79356 - 50 ml
Loctite 592 Hernon 920 Omnifit 790	White	Pipe sealant with Teflon for moderate pressures. Temp. range: -54 to 149°C (-65 to 300°F)	26695 - 6 ml 73289 - 50 ml
Loctite 515 Hernon 910 Omnifit 10	Purple	Form-in-place gasket for flexible joints. Fills gaps up to 1.3 mm (0.05”) Temp. range: -54 to 149°C (-65 to 300°F)	70735 - 50 ml

Threadlockers and Sealants



Threadlockers and Sealants (continued)

Threadlocking adhesives and sealants are specified throughout this manual by a notation of “S” plus a number (S#) and should be used where indicated. Threadlocking compounds normally break down at temperatures above 175°C (350°F). If a screw or bolt is hard to remove, heat it using a small propane torch to break down the sealant. When applying sealants, follow instructions on container. The sealants listed are recommended for use on Wacker equipment.

TYPE () = Europe	COLOR	USAGE	PART NO. – SIZE
Loctite 496 Heron 110 Omnifit Sicomet 7000	Clear	Instant adhesive for bonding rubber, metal and plastics; general purpose. For gaps up to 0.15 mm (0.006”) Read caution instructions before using. Temp. range: -54 to 82°C (-65 to 180°F)	52676 - 1 oz.
Loctite Primer T Heron Primer 10 Omnifit VC Activator	Aerosol Spray	Fast curing primer for threadlocking, retaining and sealing compounds. Must be used with stainless steel hardware. Recommended for use with gasket sealants.	2006124-6 oz.

Torque Values

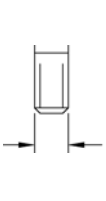
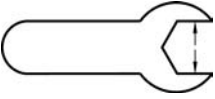
Metric Fasteners (DIN)

	TORQUE VALUES (Based on Bolt Size and Hardness)						WRENCH SIZE			
	8.8		10.9		12.9					
Size	Nm	ft.lb.	Nm	ft.lb.	Nm	ft.lb.	Metric	Inch	Metric	Inch
M3	1.2	*11	1.6	*14	2.1	*19	5.5	7/32	2.5	–
M4	2.9	*26	4.1	*36	4.9	*43	7	9/32	3	–
M5	6.0	*53	8.5	6	10	7	8	5/16	4	–
M6	10	7	14	10	17	13	10	–	5	–
M8	25	18	35	26	41	30	13	1/2	6	–
M10	49	36	69	51	83	61	17	11/16	8	–
M12	86	63	120	88	145	107	19	3/4	10	–
M14	135	99	190	140	230	169	22	7/8	12	–
M16	210	155	295	217	355	262	24	15/16	14	–
M18	290	214	405	298	485	357	27	1-1/16	14	–
M20	410	302	580	427	690	508	30	1-1/4	17	–

1 ft.lb. = 1.357 Nm





* = in.lb.

1 inch = 25.4 mm

Torque Values

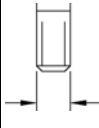
Torque Values (continued)

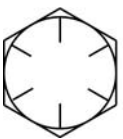
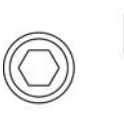
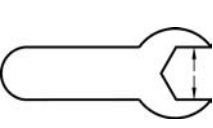
Inch Fasteners (SAE)

	 SAE 5		 SAE 8							
	Nm	ft.lb.	Nm	ft.lb.	Nm	ft.lb.	Metric	Inch	Metric	Inch
No.4	0.7	*6	1.0	*14	1.4	*12	5.5	1/4	–	3/32
No.6	1.4	*12	1.9	*17	2.4	*21	8	5/16	–	7/64
No.8	2.5	*22	3.5	*31	4.7	*42	9	11/32	–	9/64
No.10	3.6	*32	5.1	*45	6.8	*60	–	3/8	–	5/32
1/4	8.1	6	12	9	16	12	–	7/16	–	3/32
5/16	18	13	26	19	33	24	13	1/2	–	1/4
3/8	31	23	45	33	58	43	–	9/16	–	5/16
7/16	50	37	71	52	94	69	16	5/8	–	3/8
1/2	77	57	109	80	142	105	19	3/4	–	3/8
9/16	111	82	156	115	214	158	–	13/16	–	–
5/8	152	112	216	159	265	195	24	15/16	–	1/2
3/4	271	200	383	282	479	353	–	1-1/8	–	5/8

1 ft.lb. = 1.357 Nm

* = in.lb.

1 inch = 25.4 mm

