



EGCP-2 **Engine Generator Control Package**

8406-120, 150–300 Vac PT Input, 9–32 Vdc
8406-121, 50–150 Vac PT Input, 9–32 Vdc

Installation and Operation Manual



General Precautions

Read this entire manual and all other publications pertaining to the work to be performed before installing, operating, or servicing this equipment.

Practice all plant and safety instructions and precautions.

Failure to follow instructions can cause personal injury and/or property damage.



Revisions

This publication may have been revised or updated since this copy was produced. To verify that you have the latest revision, check manual **26311**, *Revision Status & Distribution Restrictions of Woodward Technical Publications*, on the *publications page* of the Woodward website:

www.woodward.com/publications

The latest version of most publications is available on the *publications page*. If your publication is not there, please contact your customer service representative to get the latest copy.



Proper Use

Any unauthorized modifications to or use of this equipment outside its specified mechanical, electrical, or other operating limits may cause personal injury and/or property damage, including damage to the equipment. Any such unauthorized modifications: (i) constitute "misuse" and/or "negligence" within the meaning of the product warranty thereby excluding warranty coverage for any resulting damage, and (ii) invalidate product certifications or listings.



Translated Publications

If the cover of this publication states "Translation of the Original Instructions" please note:

The original source of this publication may have been updated since this translation was made. Be sure to check manual **26311**, *Revision Status & Distribution Restrictions of Woodward Technical Publications*, to verify whether this translation is up to date. Out-of-date translations are marked with . Always compare with the original for technical specifications and for proper and safe installation and operation procedures.

Revisions—Changes in this publication since the last revision are indicated by a black line alongside the text.

Woodward reserves the right to update any portion of this publication at any time. Information provided by Woodward is believed to be correct and reliable. However, no responsibility is assumed by Woodward unless otherwise expressly undertaken.

Contents

| | |
|---|-------------|
| WARNINGS AND NOTICES | VII |
| ELECTROSTATIC DISCHARGE AWARENESS | VIII |
| CHAPTER 1. GENERAL INFORMATION..... | 1 |
| Introduction | 1 |
| Regulatory Compliance | 1 |
| Control Electrical Ratings | 1 |
| Technical Specifications | 1 |
| CHAPTER 2. CONTROL OVERVIEW | 2 |
| Introduction | 2 |
| Hardware | 4 |
| Environmental Specification | 4 |
| Physical Specification | 4 |
| Accessories | 4 |
| Operator Interface | 7 |
| Navigation Procedure | 12 |
| CHAPTER 3. ELECTRICAL INSTALLATION AND SPECIFICATIONS..... | 17 |
| Electrical Connections | 17 |
| Input Power | 21 |
| Potential Transformer (PT) Inputs | 22 |
| Current Transformer (CT) Inputs | 30 |
| MPU (Speed) Input..... | 31 |
| Process Import/Export Input..... | 32 |
| Coolant Temperature and Oil Pressure Inputs..... | 33 |
| Speed Bias and Voltage Bias Outputs | 36 |
| Discrete Inputs..... | 38 |
| Relay Outputs..... | 39 |
| AC Inputs..... | 48 |
| DC Inputs and Outputs..... | 48 |
| Discrete Inputs..... | 49 |
| Discrete Outputs..... | 49 |
| Communication Ports: RS-485 & RS-422 (1 each)..... | 50 |
| Hardware Connections..... | 50 |
| Inter-control Communications (RS-485 Network) | 52 |
| Alarms and Shutdowns..... | 53 |
| CHAPTER 4. SOFTWARE OVERVIEW..... | 56 |
| Introduction | 56 |
| Status Screens | 56 |
| Security Access | 68 |
| Alarm / Event Log | 69 |
| Configuration Menus | 71 |
| Shutdowns and Alarms..... | 80 |
| Engine Control..... | 86 |
| Synchronizer..... | 88 |
| Real Load Control..... | 91 |
| Reactive Load Control | 94 |
| Process Control | 95 |
| Transfer Switch..... | 100 |
| Sequencing and Comms (Communications)..... | 102 |
| Calibration Menu | 104 |

Contents

| | |
|---|------------|
| CHAPTER 5. CONTROL FEATURES AND FUNCTIONS | 117 |
| Engine Control | 117 |
| Engine Protection | 117 |
| Generator Voltage and Reactive Load Control | 117 |
| Generator Protection | 117 |
| Mains Sensing | 118 |
| Synchronizing | 118 |
| Load Control | 118 |
| Sequencing | 118 |
| Engine Cranking | 119 |
| Idle/Rated Relay Output | 120 |
| Generator Voltage Control | 120 |
| Generator Load Control | 121 |
| Automatic Generator Loading Functions | 125 |
| Synchronizer Description | 128 |
| Generator Sequencing | 135 |
| CHAPTER 6. CALIBRATION OF CONTROL INPUTS AND OUTPUTS | 146 |
| Introduction | 146 |
| Calibration of Generator PTs and CTs | 147 |
| Calibration of the Bus PT | 151 |
| Speed Bias Output | 152 |
| Voltage Bias Output | 152 |
| CHAPTER 7. GENERAL START-UP INSTRUCTIONS..... | 154 |
| Before Starting the Generator Set | 154 |
| Sequence of Start-up and Checking Parameters | 155 |
| Loading the Generator Set | 155 |
| CHAPTER 8. TROUBLESHOOTING | 158 |
| Control Hardware and I/O | 158 |
| Engine Control/Sensing Parameters | 159 |
| Synchronization | 160 |
| Breaker Close/Open Control | 161 |
| Real Load Control | 162 |
| Reactive Load Control | 163 |
| Sequencing | 164 |
| Mains/Bus Sensing | 165 |
| Communications | 165 |
| CHAPTER 9. DEFINITION OF TERMS | 166 |
| CHAPTER 10. SERVICE OPTIONS..... | 172 |
| Product Service Options | 172 |
| Woodward Factory Servicing Options | 173 |
| Returning Equipment for Repair | 173 |
| Replacement Parts | 174 |
| Engineering Services | 174 |
| How to Contact Woodward | 175 |
| Technical Assistance | 175 |
| APPENDIX A. CONNECTOR INFORMATION | 176 |
| APPENDIX B. SPEED BIAS CONNECTIONS..... | 178 |

Contents

| | |
|--|------------|
| APPENDIX C. VOLTAGE BIAS CONNECTIONS..... | 183 |
| Basler AVC63-12..... | 183 |
| Basler AEC63-7..... | 184 |
| Basler APR63-5..... | 185 |
| Basler APR63-5 with AMP200 | 186 |
| Basler KR2F, 4F, or 7F..... | 187 |
| Basler DECS 15 | 188 |
| Basler DECS 100 | 189 |
| Basler DECS 200 | 190 |
| Basler SR4A or SR8A | 191 |
| Basler SSR | 192 |
| Caterpillar CDVR..... | 193 |
| Caterpillar Digital Voltage Regulator | 194 |
| Caterpillar VR3 | 195 |
| Caterpillar VR6 | 196 |
| KATO KCR360 or 760..... | 197 |
| KATO K65-12B or K125-10B | 198 |
| Leroy Somer R438, R448, or R449..... | 199 |
| Leroy Somer R600 | 200 |
| Leroy Somer R610 | 201 |
| Marathon PM 100/200..... | 202 |
| Marathon 2000E..... | 203 |
| Mecc Alte UVR | 204 |
| Newage MA325 | 205 |
| Newage MA327 | 206 |
| Newage MX321/341 | 207 |
| APPENDIX D. EGCP-2 SET POINT WORKSHEET..... | 208 |
| Configuration Menu | 208 |
| Shutdown and Alarms Menu | 209 |
| Engine Control Menu..... | 212 |
| Synchronizer Menu..... | 214 |
| Real Load Control Menu..... | 215 |
| Reactive Load Control Menu | 216 |
| Process Control Menu | 217 |
| Transfer Switch Menu..... | 218 |
| Sequencing and Comms Menu | 219 |
| Calibration Menu | 220 |
| DECLARATIONS..... | 222 |
| EGCP-2 CONTROL SPECIFICATIONS | 223 |

Illustrations and Tables

| | |
|---|----|
| Figure 2-1. Physical Outline with Dimensions of EGCP-2..... | 5 |
| Figure 2-2. EGCP-2 Interface Connections..... | 6 |
| Figure 2-3. Operator Interface | 7 |
| Figure 2-4a. EGCP-2 Navigation (1) | 12 |
| Figure 2-4b. EGCP-2 Navigation (2) | 13 |
| Figure 2-4c. EGCP-2 Navigation (3)..... | 14 |
| Figure 2-4d. EGCP-2 Navigation (4) | 15 |
| Figure 2-4e. EGCP-2 Navigation (5) | 16 |
| Figure 3-1. CageClamp Termination Blocks (example photos) | 17 |
| Figure 3-2. Recommended Single Point Grounding Scheme | 18 |
| Figure 3-3. Wiring Diagram for EGCP-2..... | 20 |
| Figure 3-4. Dip Switch Locations..... | 21 |
| Figure 3-5. Three Wire Delta PT Connections for EGCP-2 | 23 |
| Figure 3-6. Four Wire Wye PT Connections | 23 |
| Figure 3-7. Utility/Local Bus Single PT Wiring for Delta and Wye Configuration for Multiple or Single Engine Applications | 24 |
| Figure 3-8. Utility/Local Bus Single PT Wiring for Delta and Wye Configuration for Multiple or Single Engine Prime Power Applications..... | 25 |
| Figure 3-9a. PT Wiring Relationships for Generator, Bus, and Utility Inputs | 26 |
| Figure 3-10a. PT Wiring Relationships for Generator, Bus, and Utility Inputs | 28 |
| Figure 3-10b. PT Wiring Relationships for Generator, Bus, and Utility Inputs | 29 |
| Figure 3-11. Current Transfer Wiring Diagram for EGCP-2 | 30 |
| Figure 3-12. Wiring Diagram for MPU Input | 31 |
| Figure 3-13a. Wiring Diagram for Process Import/Export Input | 32 |
| Figure 3-13b. Connecting a kW Transducer Signal to Multiple EGCP-2s..... | 32 |
| Figure 3-14. Wiring Diagram for Pressure Inputs..... | 33 |
| Figure 3-15. Wiring Diagram for Temperature Inputs..... | 34 |
| Figure 3-16. Wiring Diagram for Speed Bias and Voltage Bias Outputs..... | 37 |
| Figure 3-17. Wiring Diagram for Typical Discrete I/O Connections | 39 |
| Figure 3-18. Example of the Mains Breaker NO Output Connected to Close the Mains (Utility) Breaker (ENERGIZE TO CLOSE) | 40 |
| Figure 3-19. Example Using the NC Output to Control the Mains (Utility) Contactor (ENERGIZE TO OPEN) | 41 |
| Figure 3-20. Example of the Generator Breaker Close NO Output Connected to Close the Generator Breaker (ENERGIZE TO CLOSE) | 42 |
| Figure 3-21. Example Using the NO Contacts to Control the Generator's Contactor (ENERGIZE TO CLOSE) | 42 |
| Figure 3-22. Example Using the NO Contacts to Control the Mains Breaker Trip (Open) Coil (ENERGIZE TO OPEN) | 45 |
| Figure 3-23. Example Using the NC Contacts to Control the Generator Breakers Open Coil (DE-ENERGIZE TO OPEN) | 46 |
| Figure 3-24. Generator Breaker and Contactor Close and Open Logic..... | 46 |
| Figure 3-25. RS-422 Communications | 51 |
| Figure 3-26. RS-485 and RS-422 Termination Diagrams | 52 |
| Figure 3-27. RS-485 Inter-Control Communications | 53 |
| Figure 4-1. System Overview Engine Off Line | 56 |
| Figure 4-2. System Status Screen—Isochronous | 58 |
| Figure 4-3. System Status Screen—Baseload..... | 58 |
| Figure 4-4. Engine Status..... | 59 |
| Figure 4-5. Generator Status (Voltage Line to Neutral) | 60 |
| Figure 4-6. I/O Status | 61 |
| Figure 4-7. Synchronizer Status | 62 |
| Figure 4-8. kW Load Status..... | 63 |

Illustrations and Tables

| | |
|---|-----|
| Figure 4-9. PF /kVAR Status | 64 |
| Figure 4-10. Sequencing Menu | 65 |
| Figure 4-11. Sequencing Menu (Multi-Unit) | 66 |
| Figure 4-12. ATS (Automatic Transfer Switch) Status | 67 |
| Figure 4-13. Security Code Display | 68 |
| Figure 4-14. Alarm / Event Screen | 69 |
| Figure 4-15. Empty Event Log | 70 |
| Figure 4-16a. Configuration Menu List (Screen 1) | 71 |
| Figure 4-16b. Configuration Menu List (Screen 2) | 71 |
| Figure 4-16c. Configuration Menu List (Screen 3) | 72 |
| Figure 4-17. Program Configuration Error | 73 |
| Figure 4-18. AC Power Triangle | 76 |
| Figure 4-19. Breaker Logic and Contactor Logic | 79 |
| Figure 4-20. Generator High/Low Voltage Alarms | 80 |
| Figure 4-21. Generator Over/Under Frequency | 81 |
| Figure 4-22. Delay Time is 10 Seconds, Current goes to 190 A, an Alarm or Shutdown will be Received in 30 Seconds | 83 |
| Figure 4-23. Delay Time is 10 Seconds, Current goes to 200 A, an Alarm or Shutdown will be Received in 15 Seconds | 83 |
| Figure 4-24. Delay Time is 10 Seconds, Current goes to 220 A, an Alarm or Shutdown will be Received in 7.5 Seconds | 84 |
| Figure 4-25. Reverse Power | 85 |
| Figure 4-26. Typical Circuit Using Permissive Function and Run for Auto/Manual Synchronizing | 88 |
| Figure 4-27. Voltage Matching (1% set point) | 89 |
| Figure 4-28. Maximum Phase Window = 10 Degrees | 90 |
| Figure 4-29. EGCP-2 Control Dip Switch | 95 |
| Figure 4-30. Direct (Export) Process Action | 96 |
| Figure 4-31. Indirect (Import Power) Process Action | 96 |
| Figure 4-32. Direct (Import/Export) Process Action | 96 |
| Figure 4-33. Process In Scale | 105 |
| Figure 4-34. Measured vs. Monitored | 105 |
| Figure 4-35. Typical AVR with Aux Input (Newage SX-440) | 107 |
| Figure 4-36. Typical AVR with External Voltage Adjust Potentiometer | 107 |
| Figure 4-37. AVR Droop | 108 |
| Figure 4-38. Oil Pressure Sensor Curve | 112 |
| Figure 4-39. Water Temperature Curves | 115 |
| Figure 4-40. EGCP-2 Water Temperature Characteristics | 115 |
| Figure 5-1. Droop Mode | 122 |
| Figure 5-2. Isochronous Mode | 123 |
| Figure 5-3. Droop/Isochronous Load Sharing | 124 |
| Figure 5-4. Synchronizer Time Line—Standard Sequence | 132 |
| Figure 5-5. Loss of Mains Detection Active | 133 |
| Figure 5-6. Generator Off Line | 133 |
| Figure 5-7. Mains Parallel Unit with Voltage/Frequency Detect | 134 |
| Figure 5-8. Mains Parallel Unit(s) with Load Surge Detect | 134 |
| Figure 5-9. Typical Automatic Sequencing Scenario | 136 |
| Figure 5-10. Original System Configuration | 139 |
| Figure 5-11. After a Change of Priority—Units Not Operating | 139 |
| Figure 5-12. Original System Configuration | 140 |
| Figure 5-13. Master transfers to Unit 2 | 140 |
| Figure 5-14. Changing the Priority of a Slave Unit | 142 |
| Figure 5-15. Changing the Priority of a Slave Unit | 142 |

Illustrations and Tables

| | |
|---|-----|
| Figure 5-16. Changing the Priority of a Slave Unit | 143 |
| Figure 5-17. Changing the Priority of a Slave Unit | 143 |
| Figure 5-18. Changing the Priority of a Slave Unit | 144 |
| Figure 5-19. Changing the Priority of a Slave Unit | 144 |
| Figure 6-1. Relationship Between Voltage Bias and Generator Voltage | 153 |
| Table 4-1. Overcurrent Level Chart | 82 |
| Table 4-2. Reverse Power Chart | 84 |



HIGH VOLTAGE—Only authorized personnel knowledgeable of the risks posed by live electrical equipment should perform the calibration and checkout procedure.

Warnings and Notices

Important Definitions



This is the safety alert symbol. It is used to alert you to potential personal injury hazards. Obey all safety messages that follow this symbol to avoid possible injury or death.

- **DANGER**—Indicates a hazardous situation which, if not avoided, will result in death or serious injury.
- **WARNING**—Indicates a hazardous situation which, if not avoided, could result in death or serious injury.
- **CAUTION**—Indicates a hazardous situation which, if not avoided, could result in minor or moderate injury.
- **NOTICE**—Indicates a hazard that could result in property damage only (including damage to the control).
- **IMPORTANT**—Designates an operating tip or maintenance suggestion.

WARNING

**Overspeed /
Overtemperature /
Overpressure**

The engine, turbine, or other type of prime mover should be equipped with an overspeed shutdown device to protect against runaway or damage to the prime mover with possible personal injury, loss of life, or property damage.

The overspeed shutdown device must be totally independent of the prime mover control system. An overtemperature or overpressure shutdown device may also be needed for safety, as appropriate.

WARNING

**Personal Protective
Equipment**

The products described in this publication may present risks that could lead to personal injury, loss of life, or property damage. Always wear the appropriate personal protective equipment (PPE) for the job at hand. Equipment that should be considered includes but is not limited to:

- Eye Protection
- Hearing Protection
- Hard Hat
- Gloves
- Safety Boots
- Respirator

Always read the proper Material Safety Data Sheet (MSDS) for any working fluid(s) and comply with recommended safety equipment.

WARNING

Start-up

Be prepared to make an emergency shutdown when starting the engine, turbine, or other type of prime mover, to protect against runaway or overspeed with possible personal injury, loss of life, or property damage.

WARNING

**Automotive
Applications**

On- and off-highway Mobile Applications: Unless Woodward's control functions as the supervisory control, customer should install a system totally independent of the prime mover control system that monitors for supervisory control of engine (and takes appropriate action if supervisory control is lost) to protect against loss of engine control with possible personal injury, loss of life, or property damage.

NOTICE**Battery Charging
Device**

To prevent damage to a control system that uses an alternator or battery-charging device, make sure the charging device is turned off before disconnecting the battery from the system.

Electrostatic Discharge Awareness

NOTICE**Electrostatic
Precautions**

Electronic controls contain static-sensitive parts. Observe the following precautions to prevent damage to these parts:

- Discharge body static before handling the control (with power to the control turned off, contact a grounded surface and maintain contact while handling the control).
- Avoid all plastic, vinyl, and Styrofoam (except antistatic versions) around printed circuit boards.
- Do not touch the components or conductors on a printed circuit board with your hands or with conductive devices.

To prevent damage to electronic components caused by improper handling, read and observe the precautions in Woodward manual **82715**, *Guide for Handling and Protection of Electronic Controls, Printed Circuit Boards, and Modules*.

Follow these precautions when working with or near the control.

1. Avoid the build-up of static electricity on your body by not wearing clothing made of synthetic materials. Wear cotton or cotton-blend materials as much as possible because these do not store static electric charges as much as synthetics.
2. Do not remove the printed circuit board (PCB) from the control cabinet unless absolutely necessary. If you must remove the PCB from the control cabinet, follow these precautions:
 - Do not touch any part of the PCB except the edges.
 - Do not touch the electrical conductors, the connectors, or the components with conductive devices or with your hands.
 - When replacing a PCB, keep the new PCB in the plastic antistatic protective bag it comes in until you are ready to install it. Immediately after removing the old PCB from the control cabinet, place it in the antistatic protective bag.

WARNING

HIGH VOLTAGE—Protective Earth (PE) must be connected to the termination point on the back side of the unit next to the label with the \oplus symbol (or 1 of 3 other similar termination points without label) to reduce the risk of electric shock. This connection will be made using a thread-forming screw. The conductor providing the connection must have a properly sized ring lug and wire larger than or equal to 3.0 mm² (12 AWG).

Chapter 1.

General Information

Introduction

This manual describes how to Install and Operate the Woodward EGCP-2 Engine Generator Control Package, models 8406-120 and 8406-121.

Associated publications:

- 26175—Application Manual
- 26181—Communications Manual
- 26108—Security Levels Guide
- 03219—Product Specification

Regulatory Compliance

General Installation and Operation Notes and Warnings

- The EGCP-2 is suitable for use in non-hazardous locations only.
- Wiring must be in accordance with applicable electrical codes and in accordance with the authority having jurisdiction.
- Field wiring must be suitable for at least 90 °C.
- Connect ground terminal to PE (Protective Earth).
- More than one live circuit (see wiring diagram).

Control Electrical Ratings

| | |
|--|-------------------------------------|
| Nominal supply voltage range | 10–29 Vdc (12 or 24 volt systems) |
| Maximum power consumption at rated voltage | 20 W |
| Maximum PT input voltage range | 150–300 Vac rms (8406-120) |
| Maximum PT input voltage range | 50–150 Vac rms (8406-121) |
| Maximum CT current input range | 0–6 A rms |
| Maximum generator frequency range | 40–70 Hz |

Technical Specifications

The relevant accuracies for this product are:

| Element | Accuracy | Description |
|------------------|-----------------------|-------------|
| Voltage Metering | 1.0% at rated voltage | At 23±5 °C |
| Current Metering | 1.0% at 5 A ac | At 23±5 °C |
| Power Metering | 2.0% at rated V & I | At 23±5 °C |

Chapter 2.

Control Overview

Introduction

The EGCP-2 is a microprocessor based complete generator load control and engine management package. It will operate with a voltage regulator and various speed controls to automate and protect diesel or gas engine based generator sets from 400 to 3600 rpm.

Designed for generator sets up to 30,000 kW, the EGCP-2 can be configured to operate stand-alone or utility paralleled. A network of EGCP-2 controls is capable of controlling up to eight un-manned generator sets for backup power, baseload, or peak shaving applications.

Engine Control

- Engine Pre-glow Control
- Fuel Solenoid Control
- Engine Starter Control (Cranking)
- kVA Controlled Cool-down Timer
- Oil Pressure Monitoring
- Water Temperature Monitoring
- Battery Voltage Monitoring
- Speed Monitoring with Overspeed Protection
- Idle /Rated Relay

Synchronizing

- Digital signal processing to eliminate problems induced in systems with high SCR content causing multiple zero crossing of voltage waveforms.
- Adjustable maximum phase window, voltage window, and dwell times—windows as small as 2° phase error and 0.1% voltage matching respectively.
- Safe dead bus closing logic internal to the control.
- Multiple shot re-closing with adjustable time delays, auto-resynchronizing, and synchronizer time-outs all available.
- Manual voltage and speed adjusts for manual synchronizing (Sync-Check still active during manual parallels).
- Synchronization across generator and mains breakers.

Real (kW) Load Control

- True RMS power calculations for rapid, accurate load control.
- Smooth user chosen ramp rates into and out of each mode of operation.
- Isochronous load sharing of up to 8 units based on percentage loading (allows different rated machines to proportionally balance kW loads).
- Constant base loading for optimum fuel efficiency with discrete inputs to change load levels remotely.
- Import/Export control with an external watt transducer.
- Soft Utility Transfer Function
- Externally adjustable Base Load or Process Reference Levels with independent ramp rates
- kW droop provided for manual load control.

Reactive (kVAR) Control

- VAR sharing on isolated busses based on percentage reactive load (allows different rated machines to proportionally balance kVAR loads).
- Constant Power Factor or VAR control on units in Base Load or Process control mode.
- Externally adjustable VAR or PF control reference levels.

Automatic Generator Sequencing

- Automatically starts additional EGCP-2 equipped generators when load exceeds a user specified percentage of the rated load of the operating machines.
- Provides controlled unloads for engines when the load is low enough that the remaining engines will not exceed a user specified percentage of the rated load.
- Engine priority sequence can be changed from any unit or from a PC to equalize run-time.

Generator Protective Features

- Over/Under Voltage
- Over/Under Frequency
- Reverse Power (Inverse time delay)
- Reverse VARs
- Overcurrent (Inverse time delay)
- Loss of Mains (Utility) detection
- Speed/Frequency Mismatch
- Load Surge
- kVA Load Switch

Engine Protective Features

- High/Low Coolant Temperature
- High/Low Oil Pressure
- Overspeed
- Start Failure
- Six user configurable, discrete fault inputs

Communication – PC Interface

- Easy upload and download of unit configuration parameters
- A PC can control or monitor any unit at a site via RS-422 serial port using Modbus[®] * or ServLink protocol
- For complete details see Communication Manual 26181

*—Modbus is a registered trademark of Schneider Automation Inc.

Hardware

The EGCP-2 is an integrated control package. All control hardware is contained in one compact enclosure.

Figure 2-1 is a physical outline drawing with dimensions of the EGCP-2 for reference during the construction of mounting panels, etc.

To mount the EGCP-2 panel use type M5 x 12mm thread forming screws (Woodward part number 1029-529). Eight mounting screws are shipped with each control.

IMPORTANT

When mounting into an enclosure, make sure the enclosure is vented to atmosphere through a Type 4 vent tube or unsealed conduit.

Environmental Specification

| | |
|---|-----------------------------------|
| Temperature Range around outside of EGCP-2 Chassis | -20 to +70 °C — Operating |
| Relative Humidity | 95% non-condensing at 20 to 55 °C |

Physical Specification

| | |
|----------------|---|
| Enclosure Size | 282 x 358 x 69 mm 11.1 x 14.1 x 2.7 inch |
|----------------|---|

Accessories

Components needed for installation and remote communication. These items do not ship with the 8406-120 and 8406-121 part numbers—they must be ordered separately.

- 8928-301—EGCP-2 connector kit. Contains all of the mating terminal blocks for the EGCP-2. See Appendix A for mating connector information.
- 5417-551—Communication Cable for RS422. This cable will connect your PC to the EGCP-2 RS422 port. This is a point-to-point connection. It can be used with EGCP-2 software tools. Communication Manual 26181 contains the software tool information.

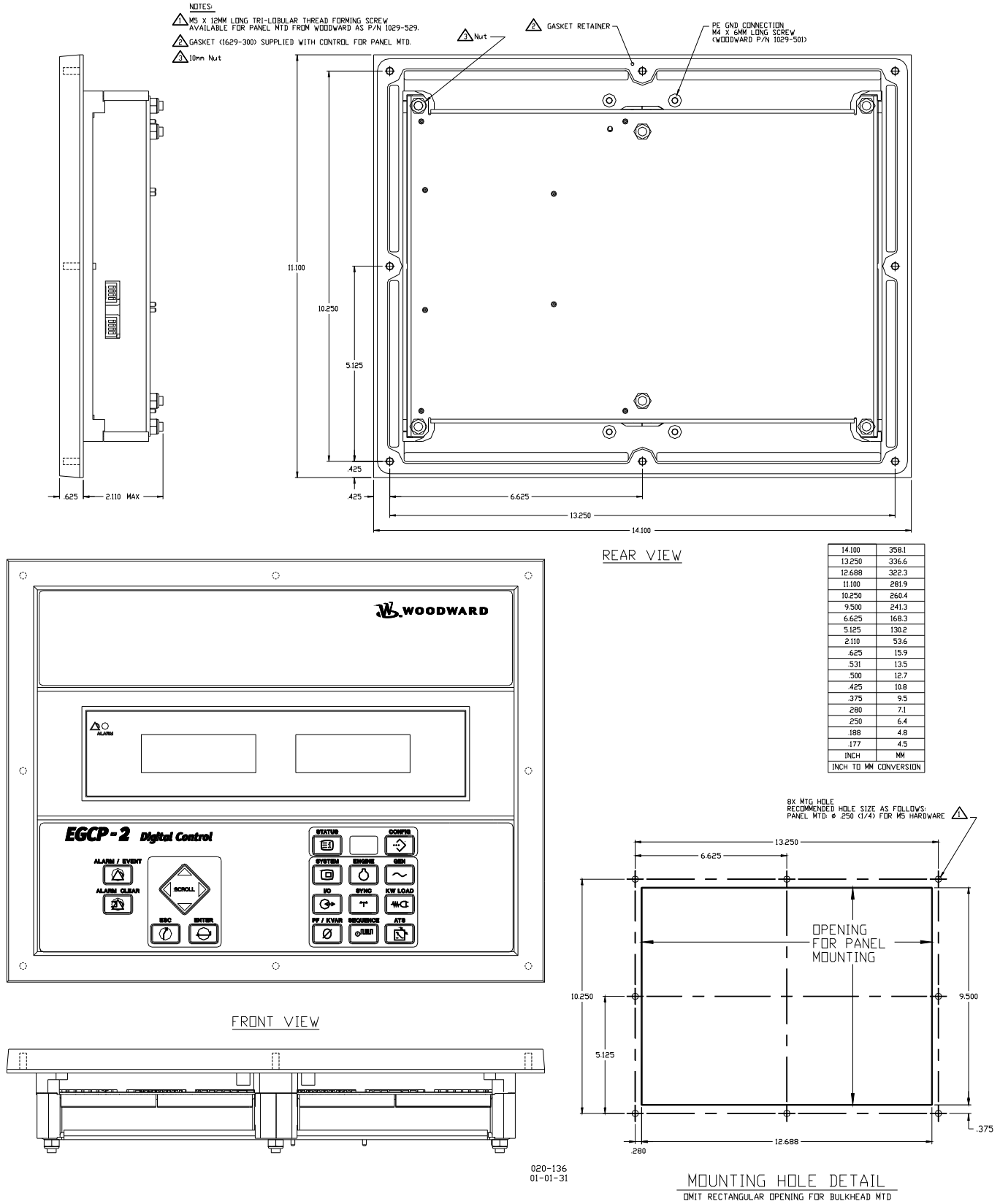

Figure 2-1. Physical Outline with Dimensions of EGCP-2

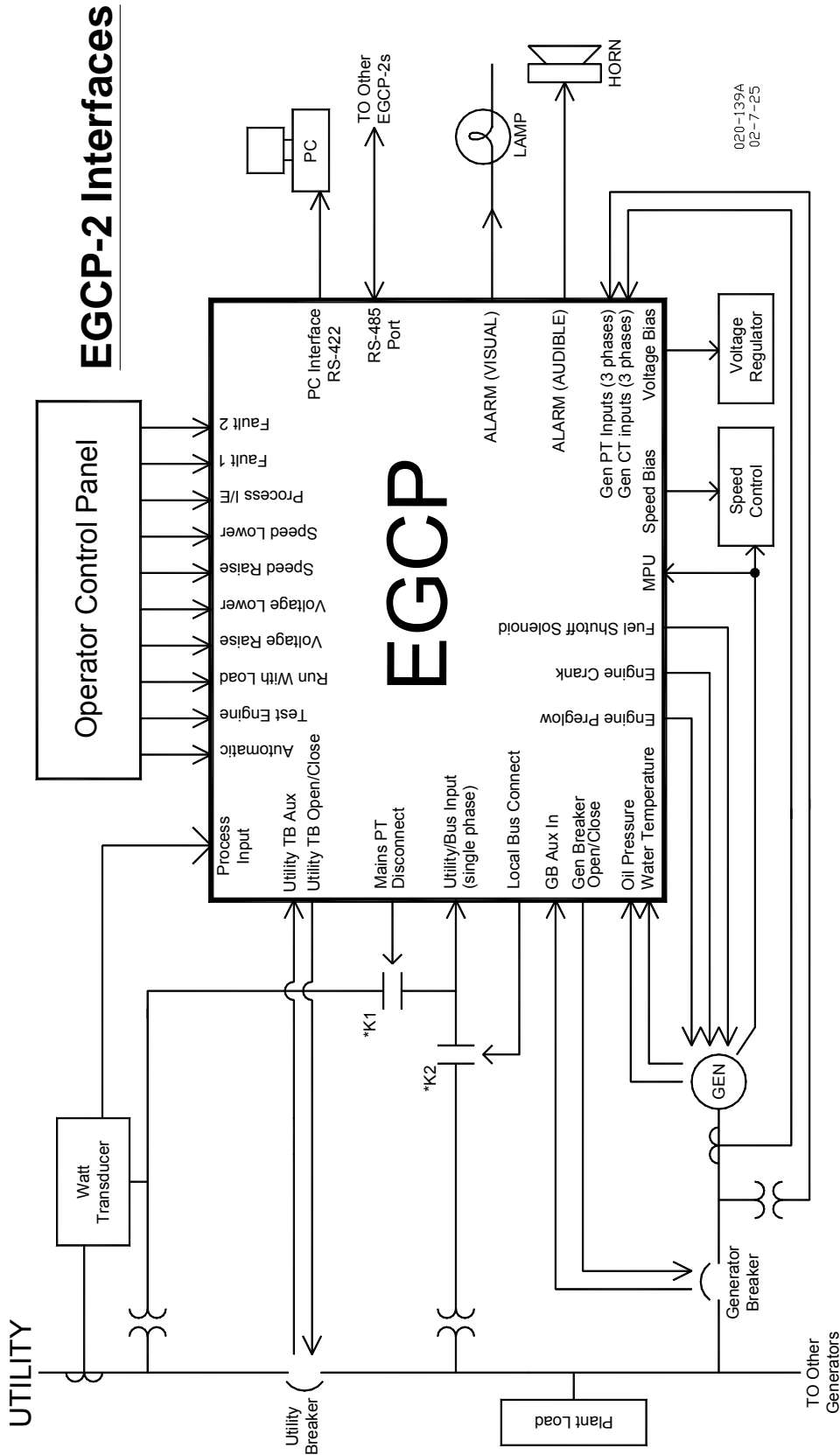

Figure 2-2. EGCP-2 Interface Connections

Operator Interface

The EGCP-2 Operator Interface is designed for simplicity and redundancy of function in all operating modes. Two backlit Liquid Crystal Display screens are used to display various operating and status information to the operator, as well as for tuning set points. The backlight on the LCD screens will stay on whenever the engine speed is above 50 rpm. When the engine is not running, the backlight will turn on whenever any key is pressed on the front panel. The backlight will turn off after 5 minutes of non-use, when the engine is not running. Additionally, in the event of a drop in supply voltage where the monitored battery voltage drops below 9.0 Vdc, the LCD back light will shut off to conserve power.

IMPORTANT

The EGCP-2 Operator Interface can only be used for unit configuration and monitoring. Unit start/stop, sync, or mode selection commands cannot be given through the EGCP-2's front panel.

WARNING

An unsafe condition could occur with improper use of these software tools. Only trained personnel should have access to these tools.

The unit's front panel screens provide eight lines of Status Information, with the option of displaying four lines of configuration or Alarm Log information. These screens allow the user to monitor and tune related parameters at the same time.



Figure 2-3. Operator Interface

A red Light Emitting Diode (LED) on the face of the control is used to indicate an alarm condition by flashing repeatedly, and to indicate a shutdown condition by staying on continuously.

There are a total of 19 keys on the keypad. Each key has the following function(s):

ALARM/EVENT LOG KEYS:

ALARM / EVENT

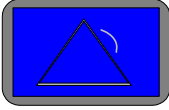

The ALARM/EVENT key is used to access the Event log. When pressed, the current alarm events will be displayed on the right hand LCD screen. When multiple alarms are logged, the up and down scroll keys will allow you to navigate within the Event log. The Event log will store up to 16 events, as more events happen the oldest alarms will be dropped off to make room for the newer events. If power is cycled to the control, the Event log will be cleared.

ALARM CLEAR

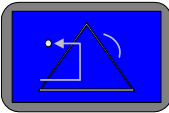

The ALARM CLEAR key is used to acknowledge and clear alarm events from the Event log. To acknowledge and clear alarm and shutdown events a Security Code of Operator Level or higher is needed. After selecting the ALARM/EVENT key:

If the Alarm mode is Visual or Warning—

1. Pressing the ALARM CLEAR key will acknowledge the selected alarm, this means the cursor will move from the Alarm Name line down to the Time and Date line.
2. Pressing the Alarm Clear key a second time will remove the event from the log.

If the Alarm/Shutdown mode is Audible, Soft Shutdown, or Hard Shutdown—

1. Pressing the ALARM CLEAR key once will de-energize Discrete Output #11, Audible Alarm. This will happen without selecting the ALARM/EVENT key and without a Security Code entered.
2. With the ALARM/EVENT key pressed, so the Event log is being displayed: Pressing the ALARM CLEAR key a second time will acknowledge the selected alarm. This means the cursor will move from the Alarm Name line down to the Time and Date line.
3. Pressing the Alarm Clear key a third time will remove the event from the log.

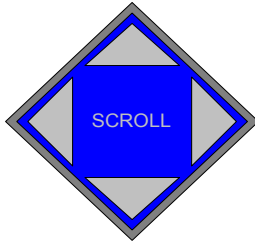
NAVIGATION and ADJUSTMENT KEYS:

The SCROLL KEY is used to move the cursor up, down, left and right. It also is used to increment and decrement values while in the configuration menus.

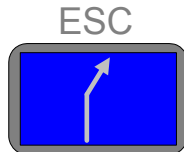

The ESCAPE KEY is used to move upwards (out of) the configuration menu levels. It also is used when tuning a value to restore the previous value, if the new value is not entered into memory (see the enter key, below).

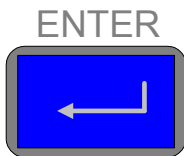

The ENTER KEY is used to move downwards (into) the configuration menu levels. It is also used to when tuning a value to enter the new value to memory. It also serves as a means to commit alarm event items to the alarm event list without removing them. This is known as logging the alarm event item. Pressing the Enter key while on the selected alarm/event item will "save" that item to the event list. If the selected alarm event was an active alarm event, the action(s) associated with the alarm event will also be cleared from the control logic.

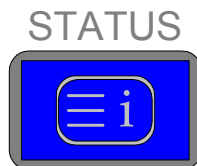
STATUS and CONFIGURATION KEYS:

The STATUS KEY, when pressed, will put both left and right LCDs into the status display mode. The status displays provide information about different items of engine and generator set operation. See the STATUS MENU buttons, below for details on the various status keys. There are no adjustment values in the status menus.

CONFIG

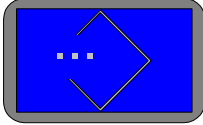

The CONFIG KEY, when pressed, will put the right hand LCD into the configuration mode. Configuration menu items will be displayed in the right hand screen. Status information will continue to be displayed in the left hand screen. Since there are various menu items and adjustments in the configuration menu, a blinking cursor is provided in the right hand display when the configure mode is active.

STATUS MENU KEYS:

The contents of the various status screens are described in Chapter 4.

SYSTEM

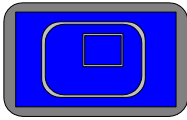

The SYSTEM STATUS key, when pressed displays the system status information. The system status display is also the default status display screen (it is always the first display shown after a power up of the control). This display shows general information about the operation of the engine generator set.

ENGINE

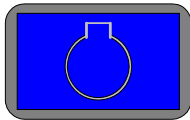

The ENGINE STATUS key, when pressed displays status information about the engine functions and operation.

GEN

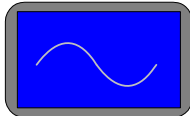

The GEN STATUS key shows three phase generator parameters when pressed.

I/O

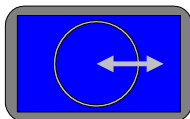

The I/O STATUS key provides the status of all the discrete inputs and outputs, as well as information on analog inputs and outputs.

SYNC

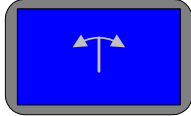

The SYNC STATUS key shows status information regarding the generator breaker and utility breaker synchronizer.

KW LOAD

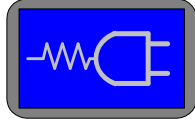

The KW LOAD STATUS key, when pressed, shows the status information for the kW load control of the EGCP-2.

PF / KVAR

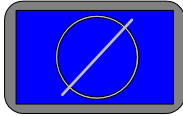

Press the PF/KVAR STATUS key to display VAR/PF Mode information, as well as three phase generator voltage and current.

SEQUENCE

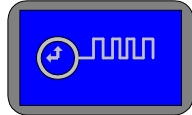

The SEQUENCE STATUS key provides sequencing information for multiple unit systems. Single unit systems, and units not in the AUTO mode will not provide status information in this screen.

ATS

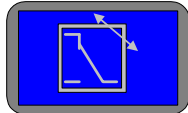

The ATS STATUS key, when pressed, displays the status information for the Automatic Transfer Switch functions.

Navigation Procedure

Figure 2-4(a-e) details a step-by-step procedure for navigating through the EGCP-2 Status screens and Configuration menus. The Keypad entries with the associated Display screens are shown.

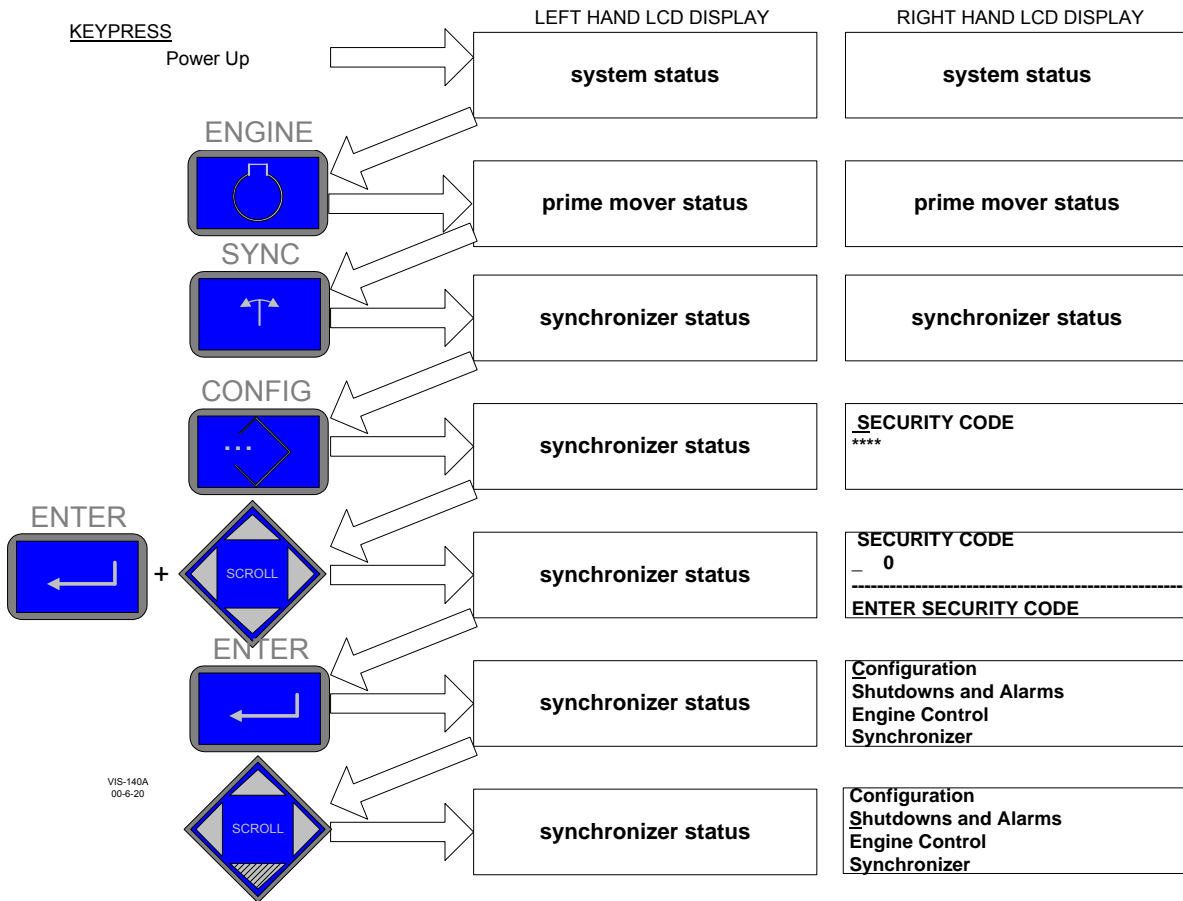

Figure 2-4a. EGCP-2 Navigation (1)

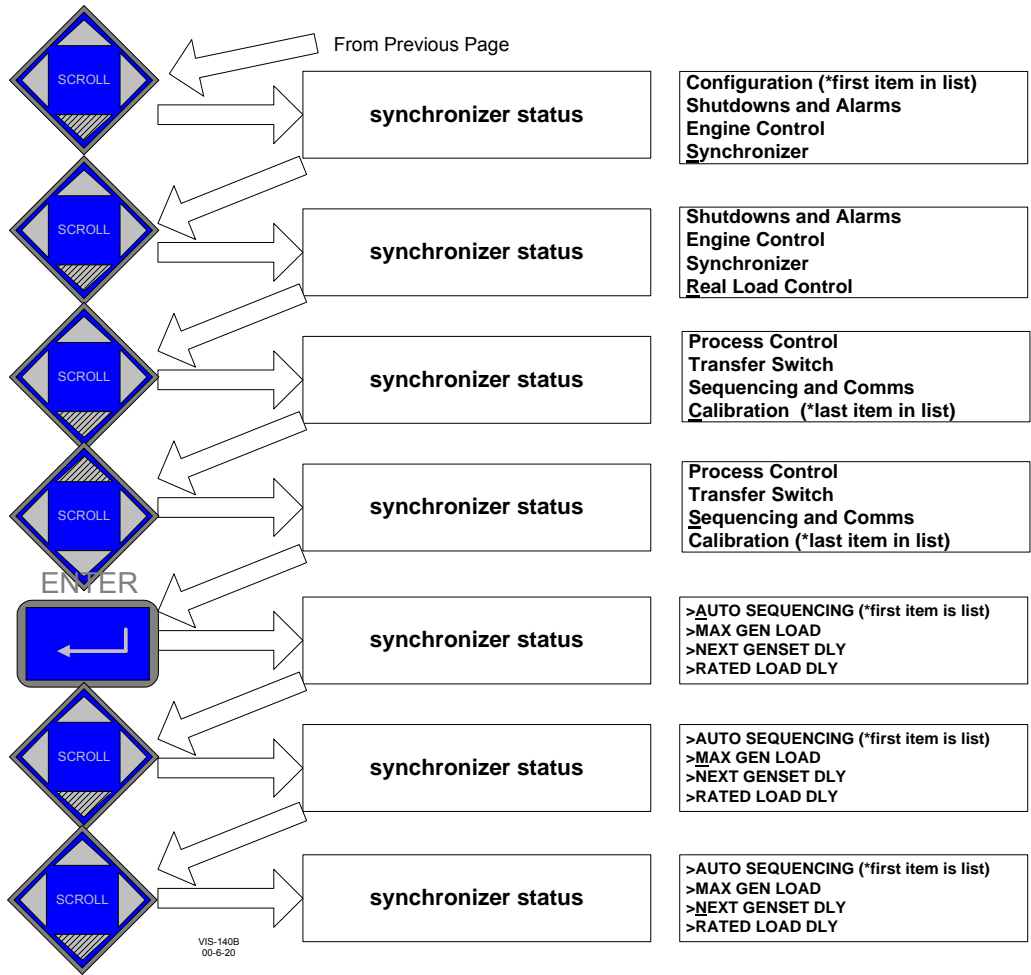

Figure 2-4b. EGCP-2 Navigation (2)

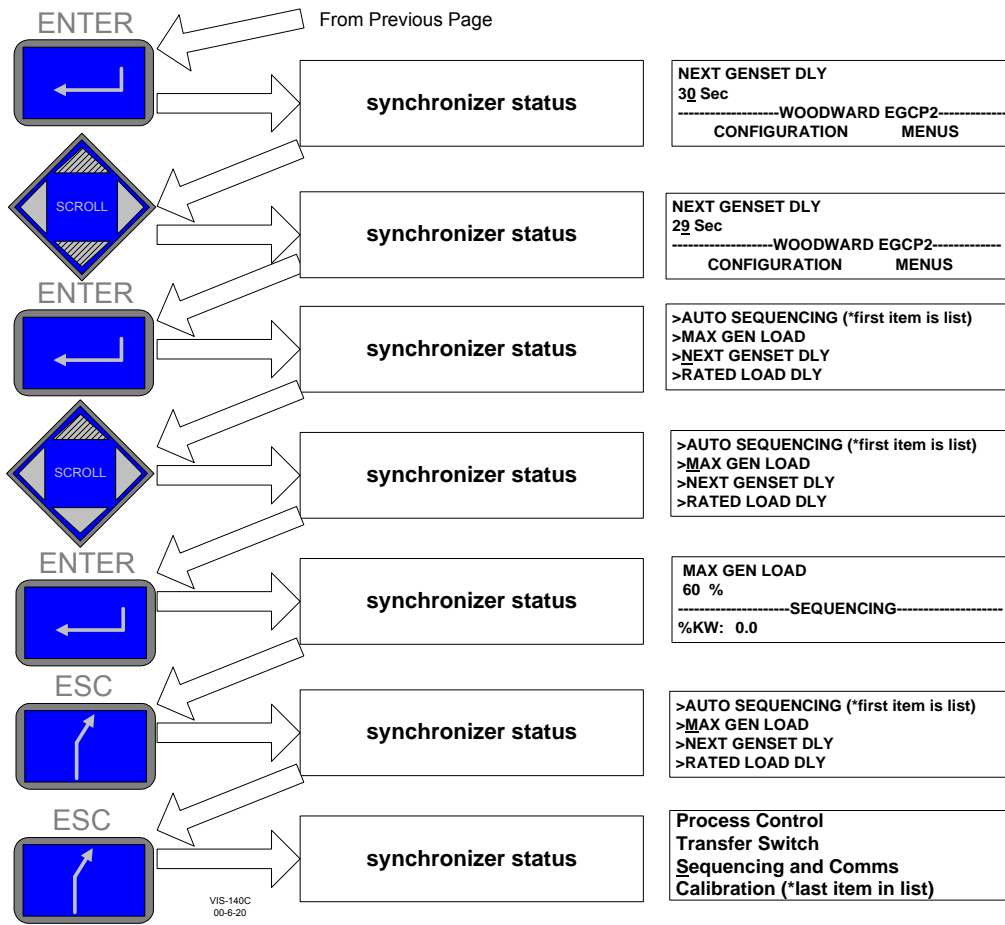

Figure 2-4c. EGCP-2 Navigation (3)

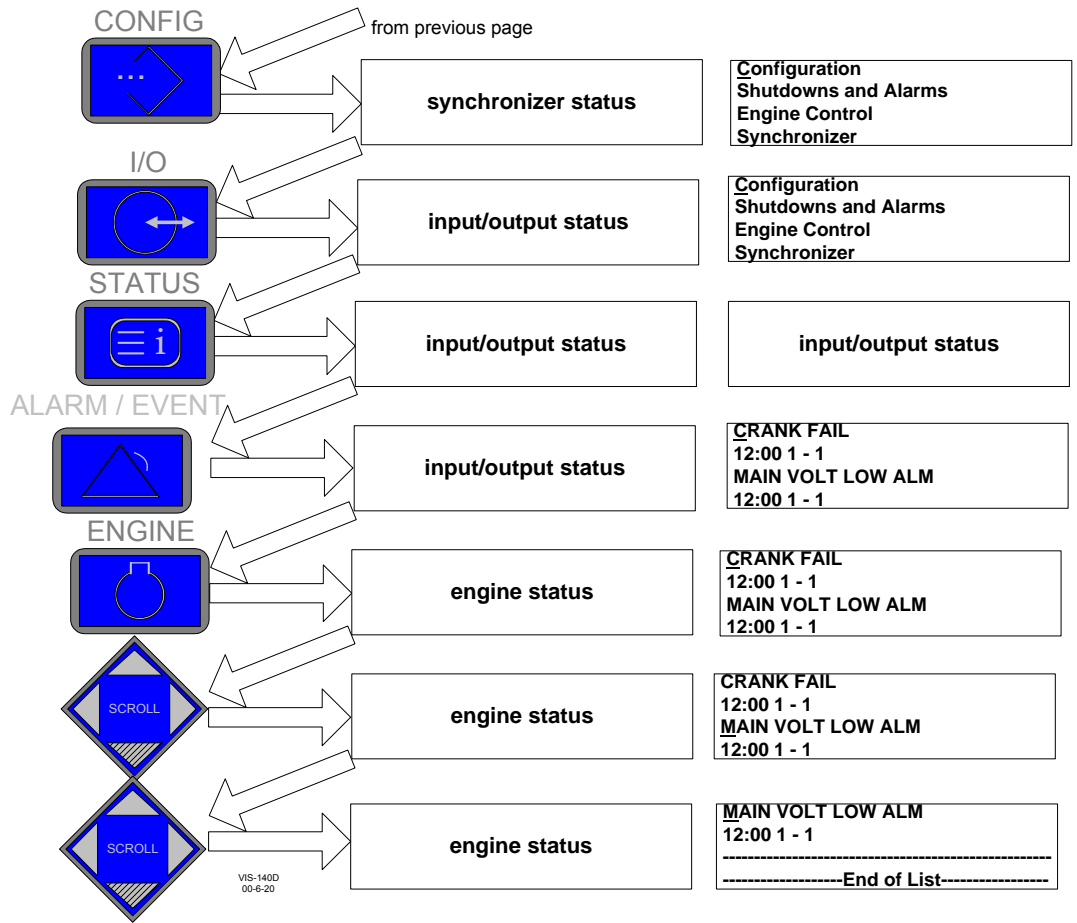

Figure 2-4d. EGCP-2 Navigation (4)

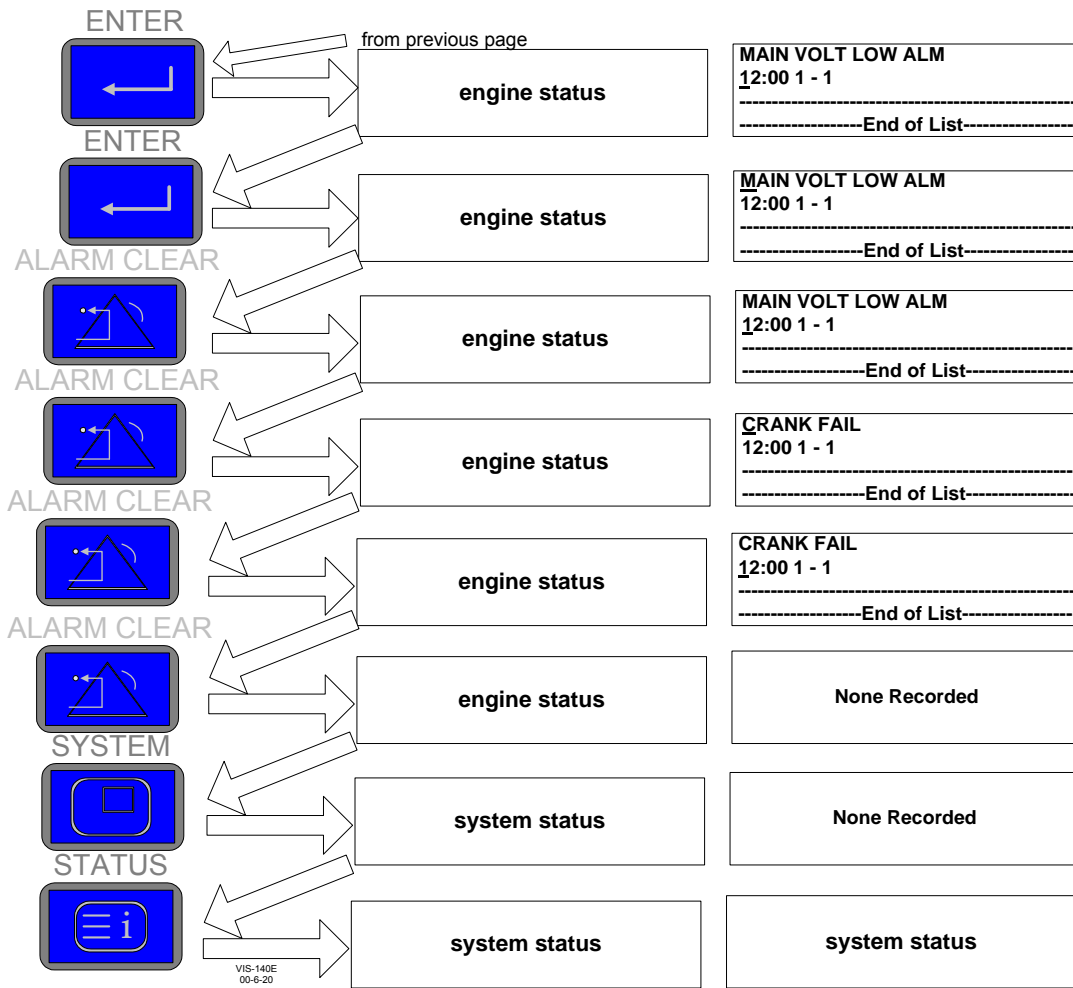

Figure 2-4e. EGCP-2 Navigation (5)

Chapter 3. Electrical Installation and Specifications

Electrical Connections

All inputs and outputs to the EGCP-2 are made through “CageClamp” terminal blocks. For noise suppression, it is recommended that all low-current wires be separated from all high-current wire.

The terminal blocks are screwless CageClamp style blocks. The spring clamp can be actuated by using a standard 3.5 mm or 1/8 inch flat bladed screwdriver (see Figure 3-1). The EGCP-2 pluggable terminal blocks accept wires from 0.08–2.5 mm² (28–12 AWG). Fixed terminal blocks accept wires from 0.08–2.5 mm² (27–12 AWG). Two 0.8 mm² (18 AWG) or three 0.5 mm² (20 AWG) wires can be easily installed in each terminal. Wires for the pluggable I/O terminals should be stripped 8–9 mm (0.3 inch) long, wires for the fixed mounted power terminals should be stripped 5–6 mm (0.2 inch) long.

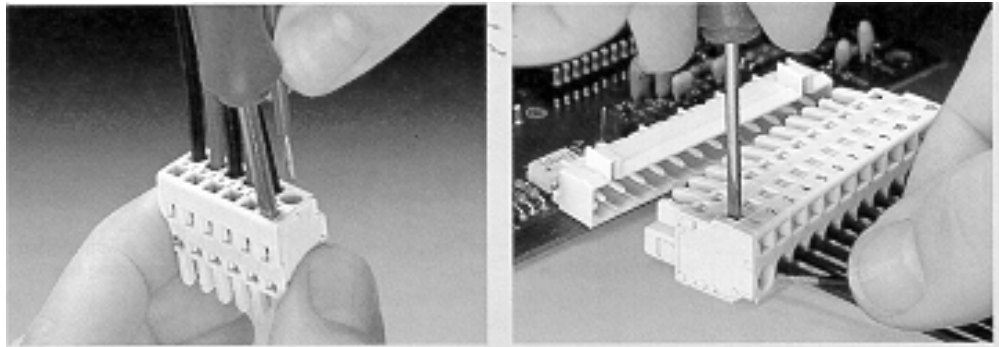

Method #1
Free Hand (Holds spring open)

Method #2
Bench (momentarily opens spring while force is applied)

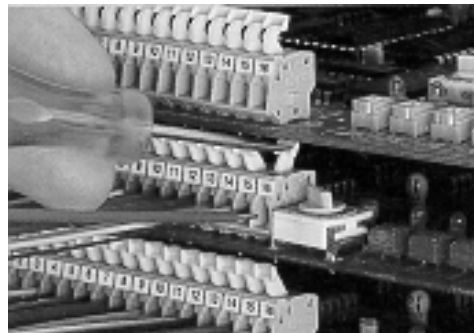

Wiring Fixed Terminal

Figure 3-1. CageClamp Termination Blocks (example photos)

Most of the EGCP-2 control's terminal blocks are designed to be removed by hand. After EGCP-2 input power is disconnected, the terminal blocks can be removed one at a time by pulling them straight out. Care should be taken not to pull the plug out at an angle as this will fracture the end terminal.

IMPORTANT

Do not tin (add solder to) the wires that terminate at the EGCP-2 terminal blocks. The spring-loaded CageClamp terminal blocks are designed to flatten stranded wire, and if those strands are tinned together, the connection loses surface area and is degraded.

Grounding for Protection Against Electric Shock

Protective Earth (PE) must be connected to the termination point on the backside of the unit next to the label with the \oplus symbol (or 1 of 3 other like termination points without label) to reduce the risk of electric shock. The EGCP-2 ships with 2 thread forming screws (M4 x 6 mm, Woodward #1029-525) for this connection. The conductor providing the connection must have a properly sized ring lug and wire larger than or equal to 3.0 mm² (12 AWG).

Recommended Grounding Practices

Providing the proper ground for the EGCP-2 is important. Improper connection of the EGCP-2 chassis to the ground plane may lead to stray currents between the reference point for the AC signal sources (current and voltage transformers), and the reference point for the sensing inputs on the EGCP-2. Differences in potential between these two points results in equalizing current flow which then produces unacceptably high common mode voltages. Common mode voltages may result in improper readings for the sensed AC inputs, or even damage to the EGCP-2 product in extreme cases. To minimize this problem, it is necessary to provide a low resistance path between the AC signal reference point, and the chassis of the EGCP-2. Typically this point is the designated ground for the generator set and related instrument transformers.

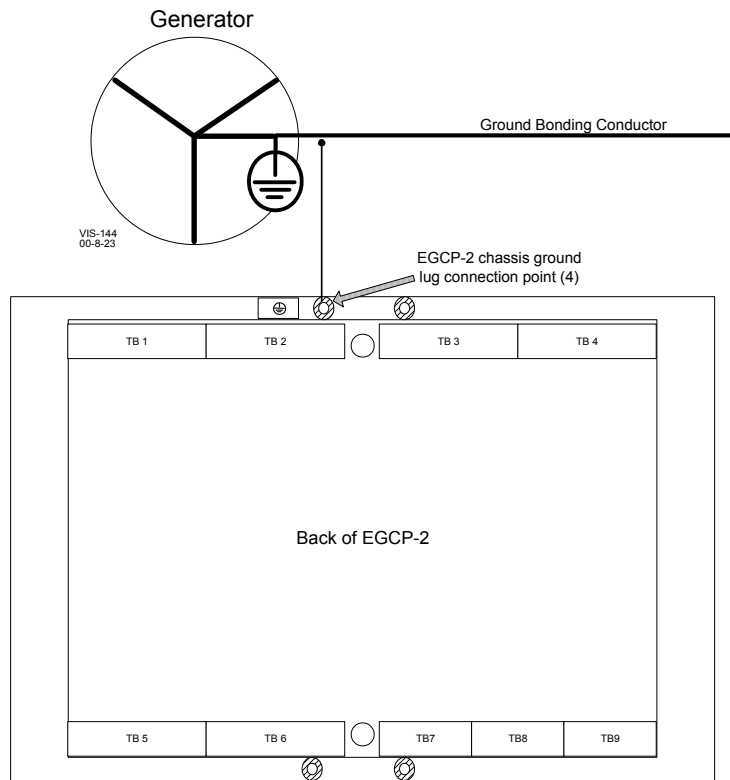

Figure 3-2. Recommended Single Point Grounding Scheme

Shields and Grounding

An individual shield termination is provided at the terminal block for each of the signals requiring shielding except for oil pressure and coolant temperature. All of these inputs should be wired using shielded, twisted-pair wiring. The exposed wire length, beyond the shield, should be limited to one inch. Relay outputs, contact inputs, and power supply wiring do not normally require shielding, but can be shielded if desired.

The EGCP-2 is designed for shield termination to earth ground at the EGCP-2. If intervening terminal blocks are used in routing a signal, the shield should be continued through the terminal block. If shield grounding is desired at the terminal block, it should be ac coupled to earth. All other shield terminations except at the EGCP-2 should be ac coupled to earth through a capacitor. A 1000 pF, 500 V capacitor is sufficient. The intent is to provide a low impedance path to earth for the shield at frequencies of 150 kHz and up. Multiple direct connections of a shield to earth risk high levels of current to flow within the shield (exception, see note on cabinet installations).

Shields can be grounded at both ends (EGCP-2 and load) if the cable length is sufficiently short (that is, within a cabinet) to prevent ground loop current in the shield.

Cabinet Installations: If the EGCP-2 is installed in a cabinet, shielded I/O can be terminated directly to the cabinet (earth ground) at the entry to the cabinet, as well as at the EGCP-2.

For noise suppression reasons, it is recommend that all low-current wires be separated from all high-current wires. Input Power ground terminal should also be wired to earth ground.

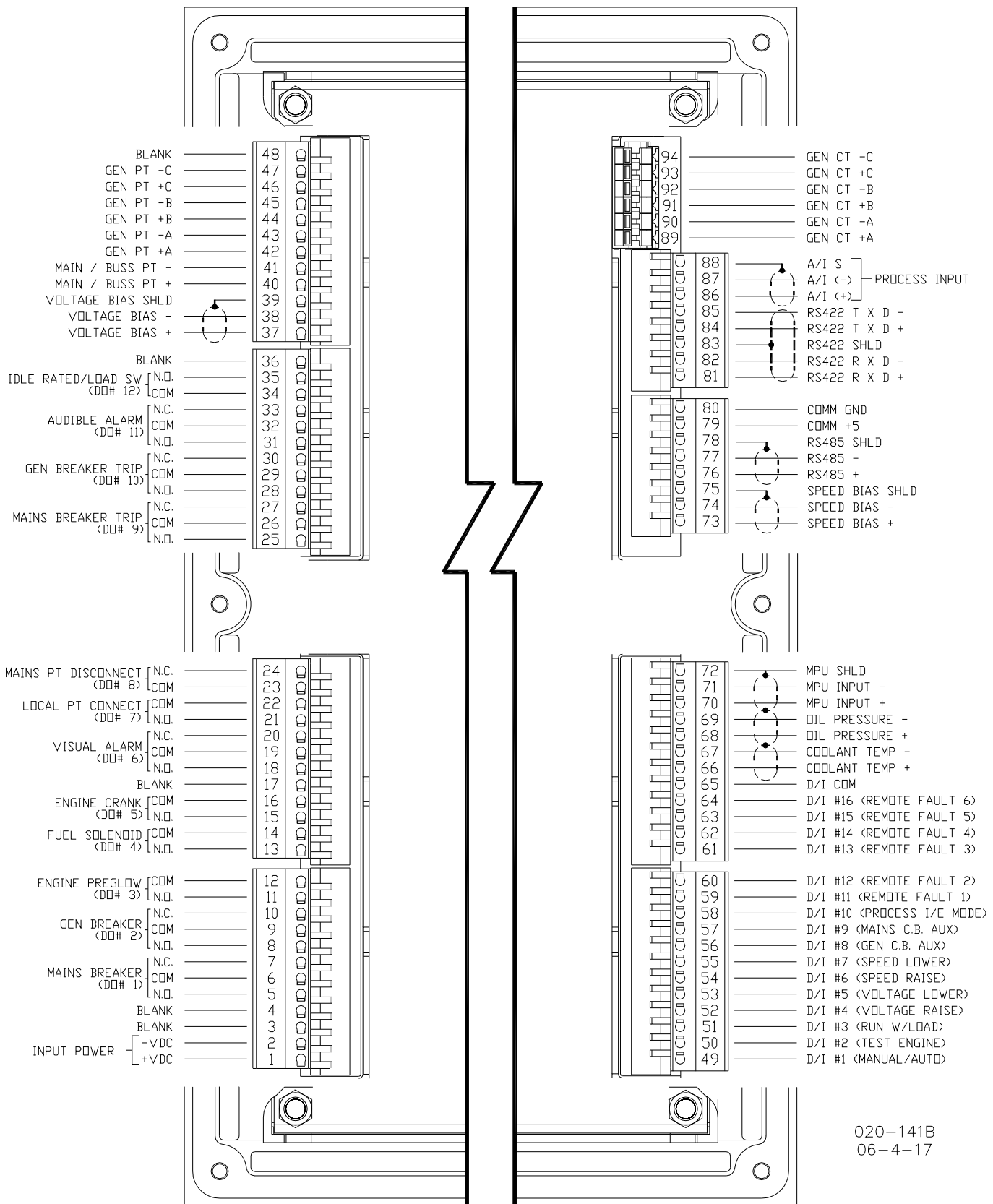

020-141B
06-4-17

Figure 3-3. Wiring Diagram for EGCP-2

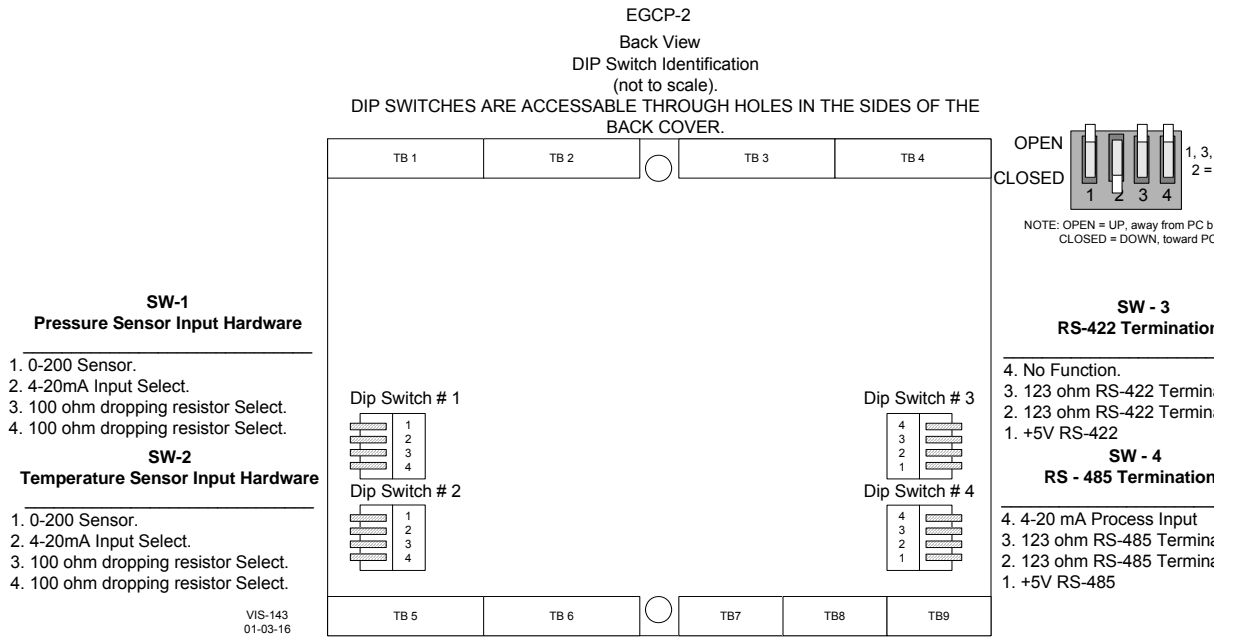

Figure 3-4. Dip Switch Locations

IMPORTANT In the drawing above, the switches will do the mentioned functions when in the CLOSED position.

Input Power

The EGCP-2 accepts any input power source that supplies a voltage within the 9-32 Vdc voltage range. It is expected that the installation of this equipment will include overcurrent protection between the power source and the EGCP-2. This overcurrent protection may be accomplished by series connection of properly rated fuses or circuit breakers (see the Input Power Ratings below for proper sizing).

Input Power Ratings

- Nominal Voltage Range: 10–29 Vdc
- Maximum Voltage Range: 9–32 Vdc
- Maximum Input Power: 20 W
- Typical Input Power: 13 W @24 Vdc
- Input Fuse Rating: 5 A (time delay with melting $I^2t \geq 100A^2sec$)
- Wire Size: Up to 12 AWG
- Holdup Time: 5 milliseconds @ 24 Vdc

Significant inrush currents are possible when current is applied to the EGCP-2 control. The magnitude of the inrush current depends on the power source impedance, so Woodward cannot specify the maximum inrush current. Time-delay fuses or circuit breakers must be used to avoid nuisance trips.

Potential Transformer (PT) Inputs

Potential Transformers (PTs) are utilized with the EGCP-2 control to allow high voltages to be stepped down to a safe level for the EGCP-2 input circuitry. The EGCP-2 control senses generator output voltage through three Generator PTs, and utility and plant-bus voltages via one shared utility/plant-bus PT.

Potential Transformer Input Ratings for 8406-120

| | |
|-------------------------|-------------|
| Number of inputs: | 4 |
| Maximum Voltage Rating: | 150–300 Vac |
| Burden: | 0.45 VA |
| Input Frequency: | 40–70 Hz |

Potential Transformer Input Ratings for 8406-121

| | |
|-------------------------|------------|
| Number of inputs: | 4 |
| Maximum Voltage Rating: | 50–150 Vac |
| Burden: | 0.25 VA |
| Input Frequency: | 40–70 Hz |

IMPORTANT

Because the same EGCP-2 input is used to sense both the utility and local bus voltages, the two PT signals must be identical in configuration (Wye or Delta), phase (A-B or A-N), and amplitude for correct input readings.

Generator PT Input Wiring

The EGCP-2 utilizes a 6-wire generator PT input configuration. This type of configuration allows the EGCP-2 to be easily wired to either Delta or Wye generators or transformers. The EGCP-2 control uses all three phases of the generator to sense both real and reactive generator power. Refer to the Figure 3-5 for Delta based wiring diagrams and Figure 3-6 for Wye based wiring diagrams. Once wired into a Delta or Wye circuit, the EGCP-2 must also be programmed to sense the correct (Delta or Wye) configuration.

Configuration menu (items affected)

1. PT Ratio
2. Voltage Input
3. Voltage Ref

Shutdown and Alarms Menu

1. Gen Volt Hi Limit and Alarm
2. Gen Volt Lo Limit and Alarm
3. Gen Freq Hi Limit and Alarm
4. Gen Freq Lo Limit and Alarm

Transfer Switch Menu

1. Main Volt High Limit and Alarm
2. Main Volt Low Limit and Alarm
3. Main Freq High Limit and Alarm
4. Main Freq Low Limit and Alarm

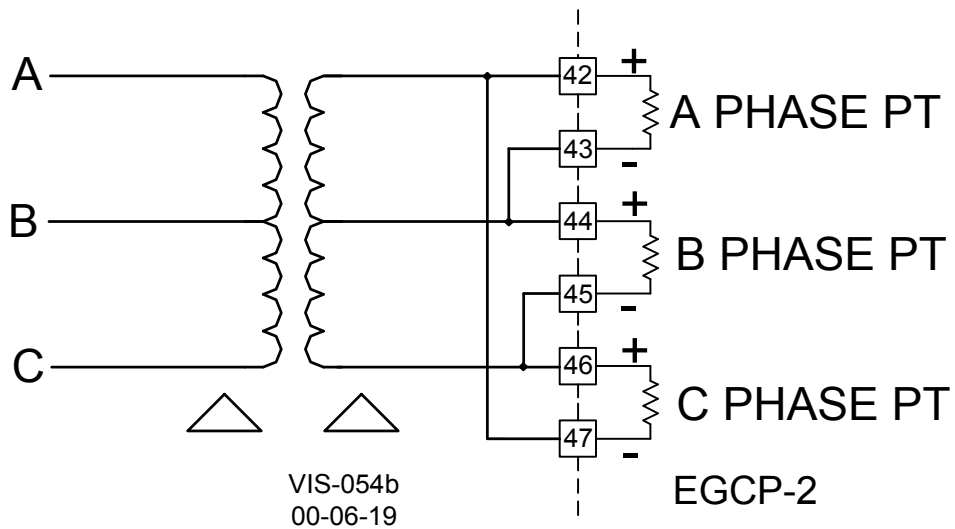

Figure 3-5. Three Wire Delta PT Connections for EGCP-2

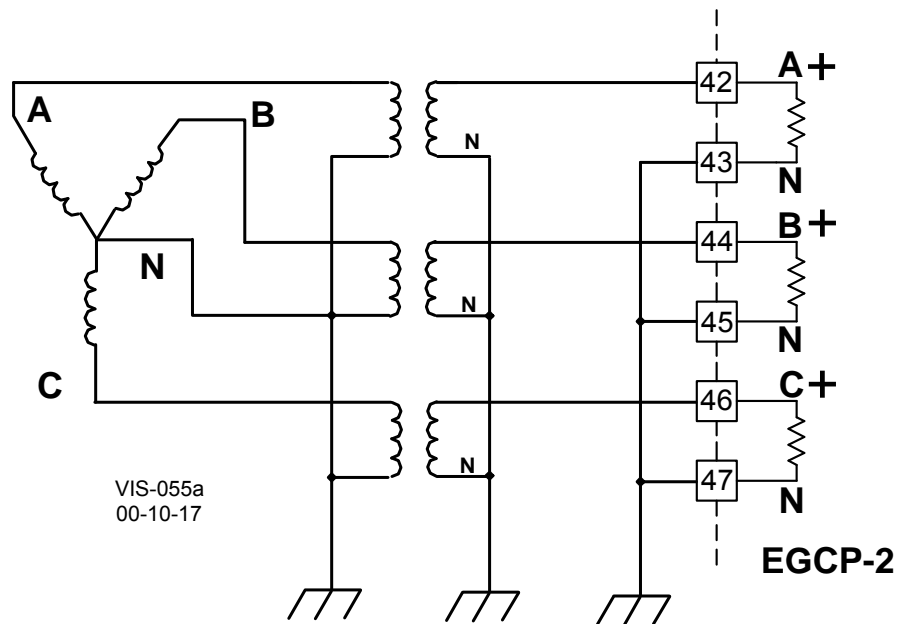

Figure 3-6. Four Wire Wye PT Connections

Utility (Mains) and Plant Bus PT Input Wiring

The EGCP-2 utilizes one PT input to sense both utility tie-line voltage and plant-bus voltage. This PT input must be the same configuration as the generator PT input. The potential transformer should be the same ratio as the generator PT input. Two Relay outputs are used by the EGCP-2 to select which voltage source to monitor, depending upon the state of the control. The EGCP-2's control logic is set up to monitor the utility tie voltage during normal operation and local bus voltage when sensing for a dead bus condition or synchronizing the generator to the local bus. Refer to Figures 3-7 and 3-8, for required input wiring configurations. This type of configuration allows the EGCP-2 to perform a break-before-make relay action when switching between voltage sources to assure that the utility PT and Bus PT never are connected.

Sequence of Mains PT Disconnect (DO8) and Local Bus PT Connect (DO7)

The EGCP-2 will command a Mains PT disconnect (DO8) when:

1. The EGCP-2 has an “AUTO” discrete input and either
 - a. A loss of Mains (LOM) is detected or
 - b. A “Run with load” discrete input.
2. The Generator Stable Delay time has been met.
3. The EGCP-2 is in the “Close Gen Breaker” mode.

When the Mains PT Disconnect changes state, the EGCP-2 has to measure less than 40 Vac on the Mains/Bus PT input (terminals 40 and 41). **If the EGCP-2 measures greater than 40 Vac after the Mains PT Disconnect command was given, the EGCP-2 senses this as a fault and will not synchronize.**

For this reason, when only one PT signal is being connected, the external relay logic to remove the incoming Mains/Bus PT signal must still be applied. The following diagrams, Figures 3-7 and 3-8 show how to connect terminals 40 and 41 for different applications.

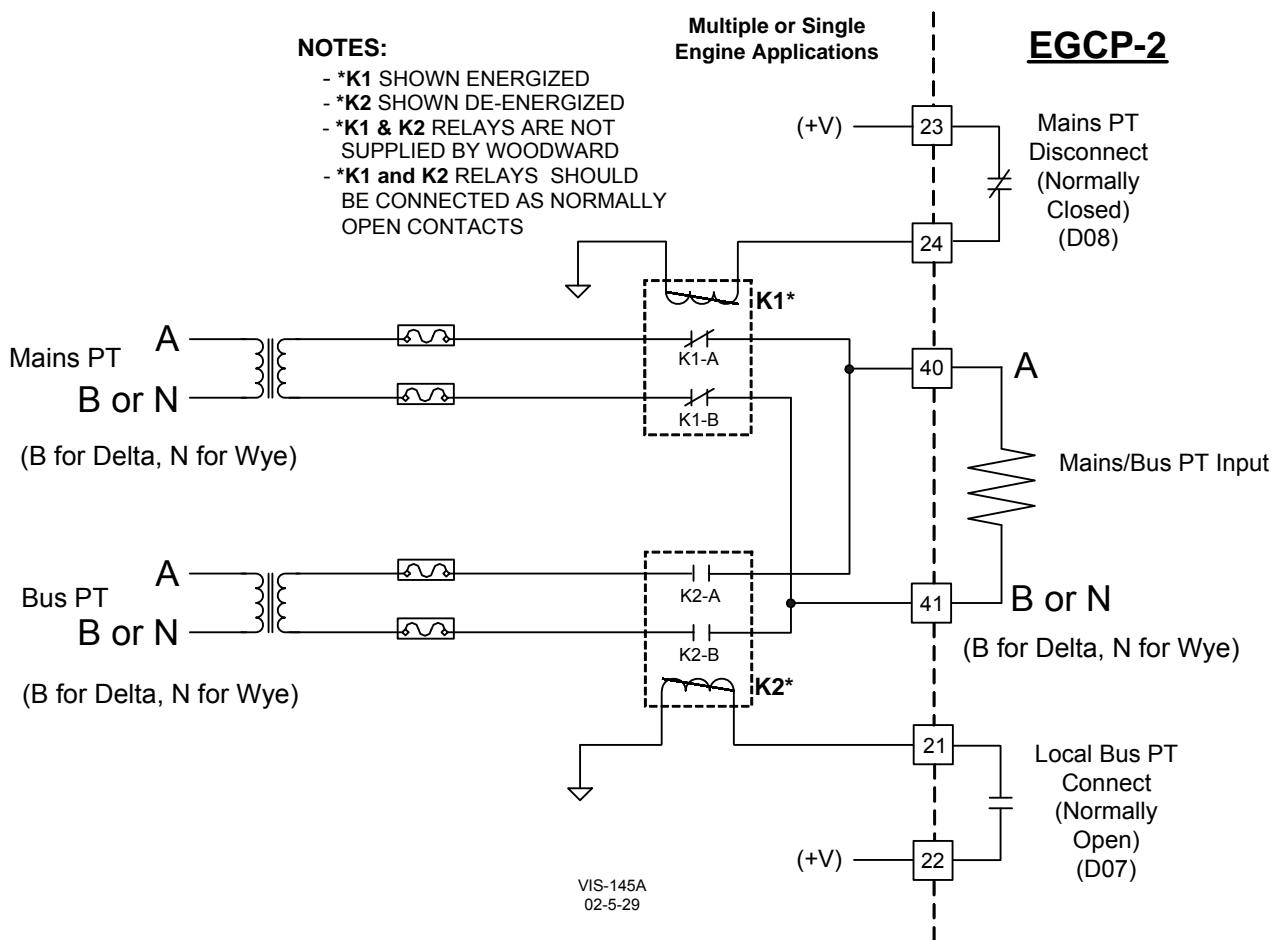

Figure 3-7. Utility/Local Bus Single PT Wiring for Delta and Wye Configuration for Multiple or Single Engine Applications

Figure 3-7 Notes:

1. For Multiple or Single Engine Applications
 - a. Loss of Mains (LOM)
 - b. Mains Parallel or No Parallel
 - c. Prime Power
2. K1 and K2 relays
 - a. Not supplied by Woodward
 - b. Relays should be connected as Normally Open contacts

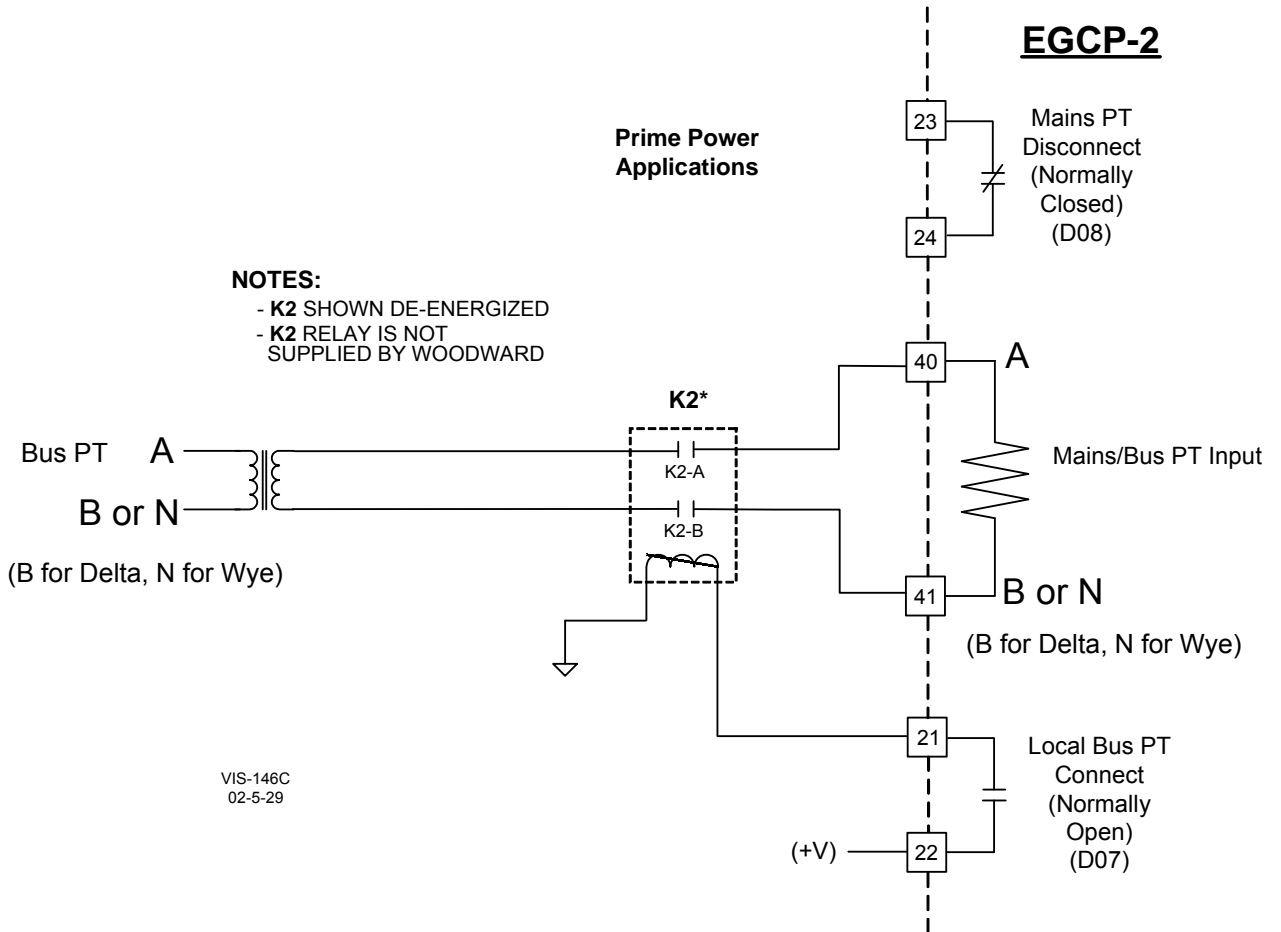

Figure 3-8. Utility/Local Bus Single PT Wiring for Delta and Wye Configuration for Multiple or Single Engine Prime Power Applications

Figure 3-8 Notes:

1. Multiple Engine Application
 - a. Prime Power
2. Single Engine Application
 - a. Prime Power
3. Uses **Bus PT only**
4. K2 relay
 - a. Not supplied by Woodward
 - b. Relay should be connected using the Normally Open contacts

Required PT Wiring Relationships

The EGCP-2 control uses its programmed PT-Ratio setting to calculate and compare all PT input voltages. Thus, the EGCP-2 control requires the following generator, utility, and plant-bus PT relationships. Figures 3-9(a & b) and 3-10 (a & b) show these relationships.

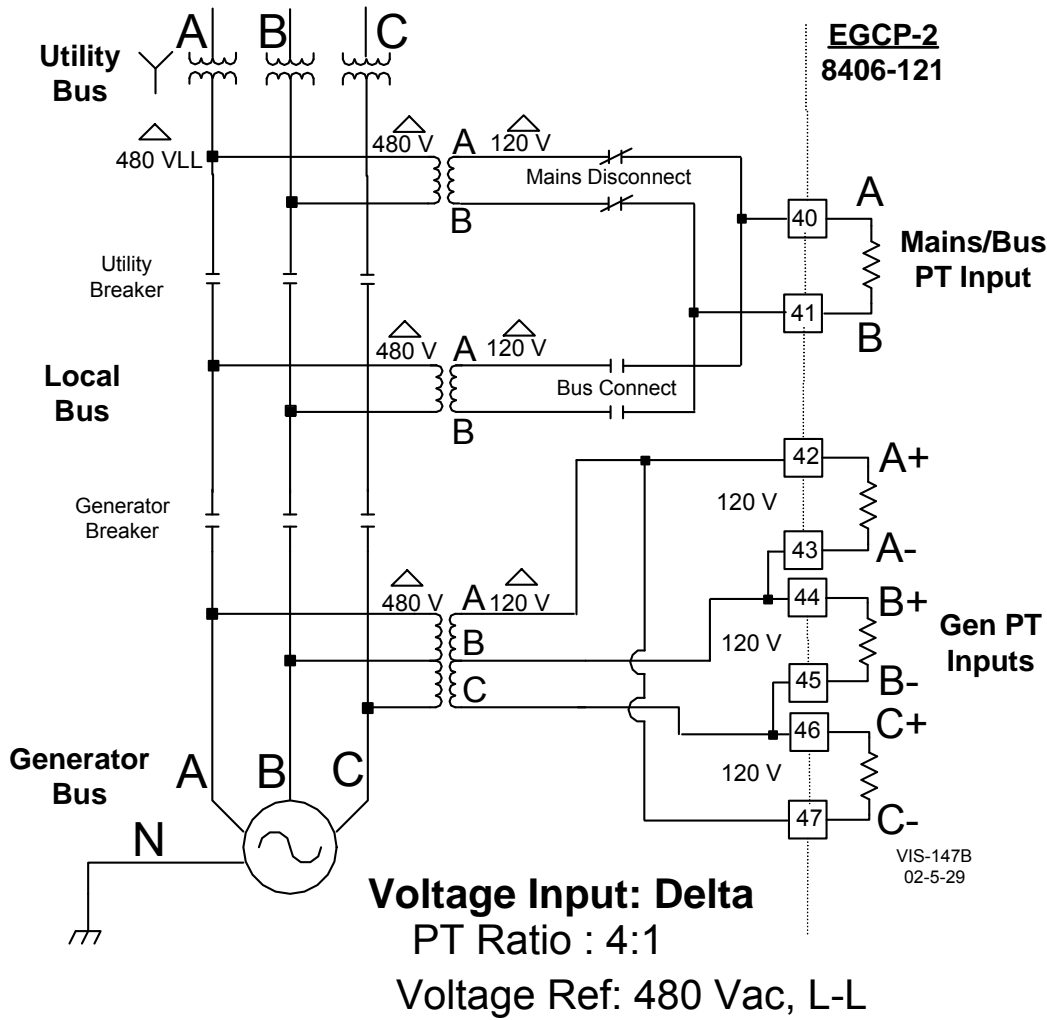

Figure 3-9a. PT Wiring Relationships for Generator, Bus, and Utility Inputs

Please Note:

1. This drawing shows EGCP-2 part number 8406-121.
2. Follow Utility/Local Bus PT wiring.

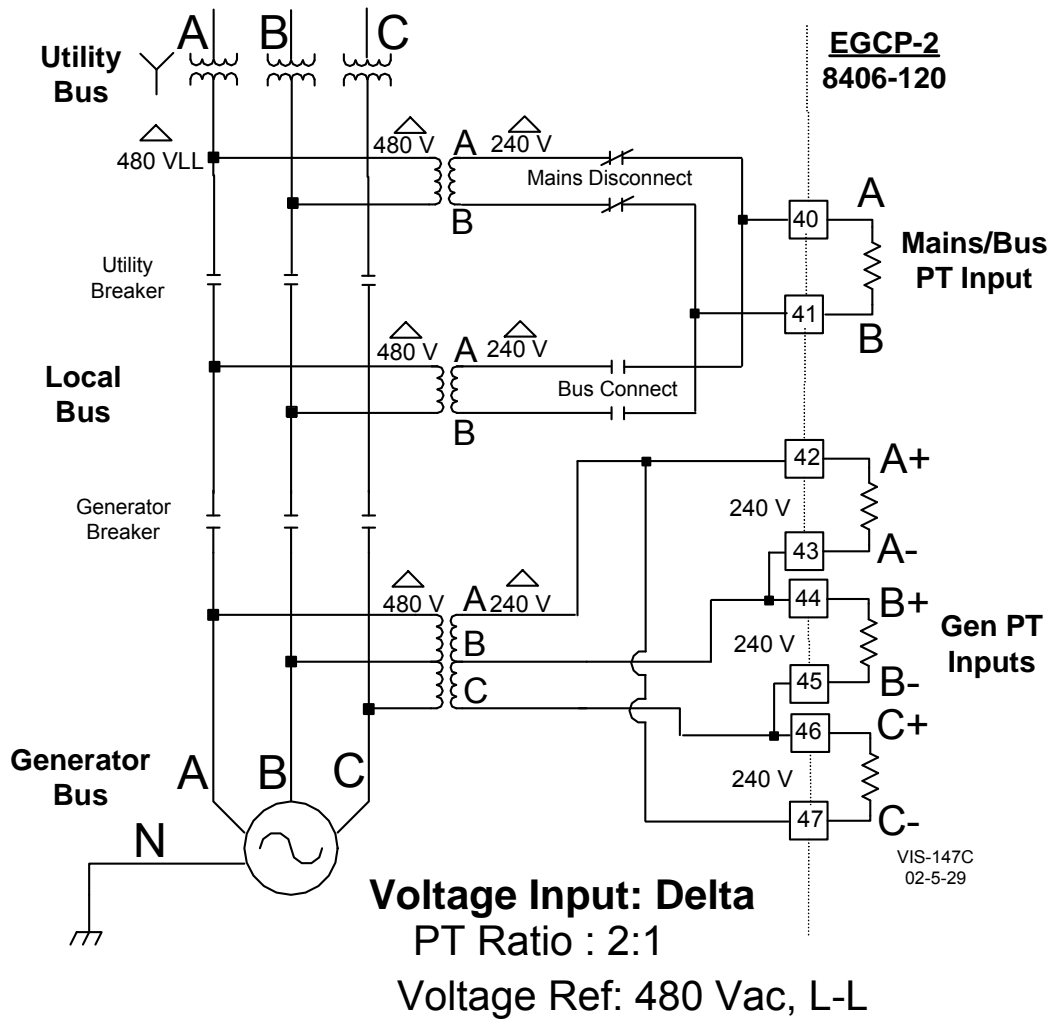

Figure 3-9b. PT Wiring Relationships for Generator, Bus, and Utility Inputs

Please Note:

1. This drawing shows EGCP-2 part number 8406-120.
2. Follow Utility/Local Bus PT wiring.

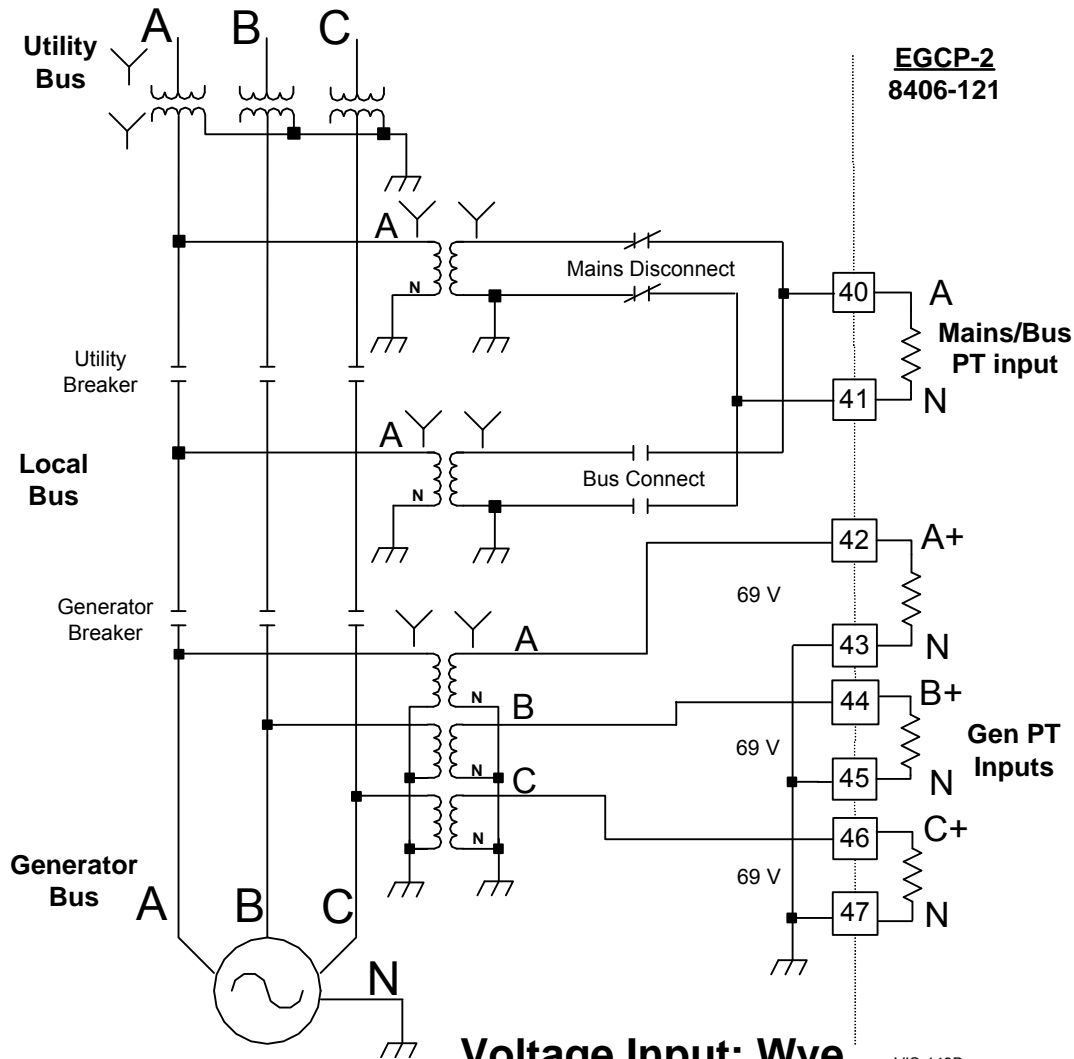

Figure 3-10a. PT Wiring Relationships for Generator, Bus, and Utility Inputs

Please Note:

1. This drawing shows EGCP-2 part number 8406-121.
2. Follow Utility/Local Bus PT wiring.

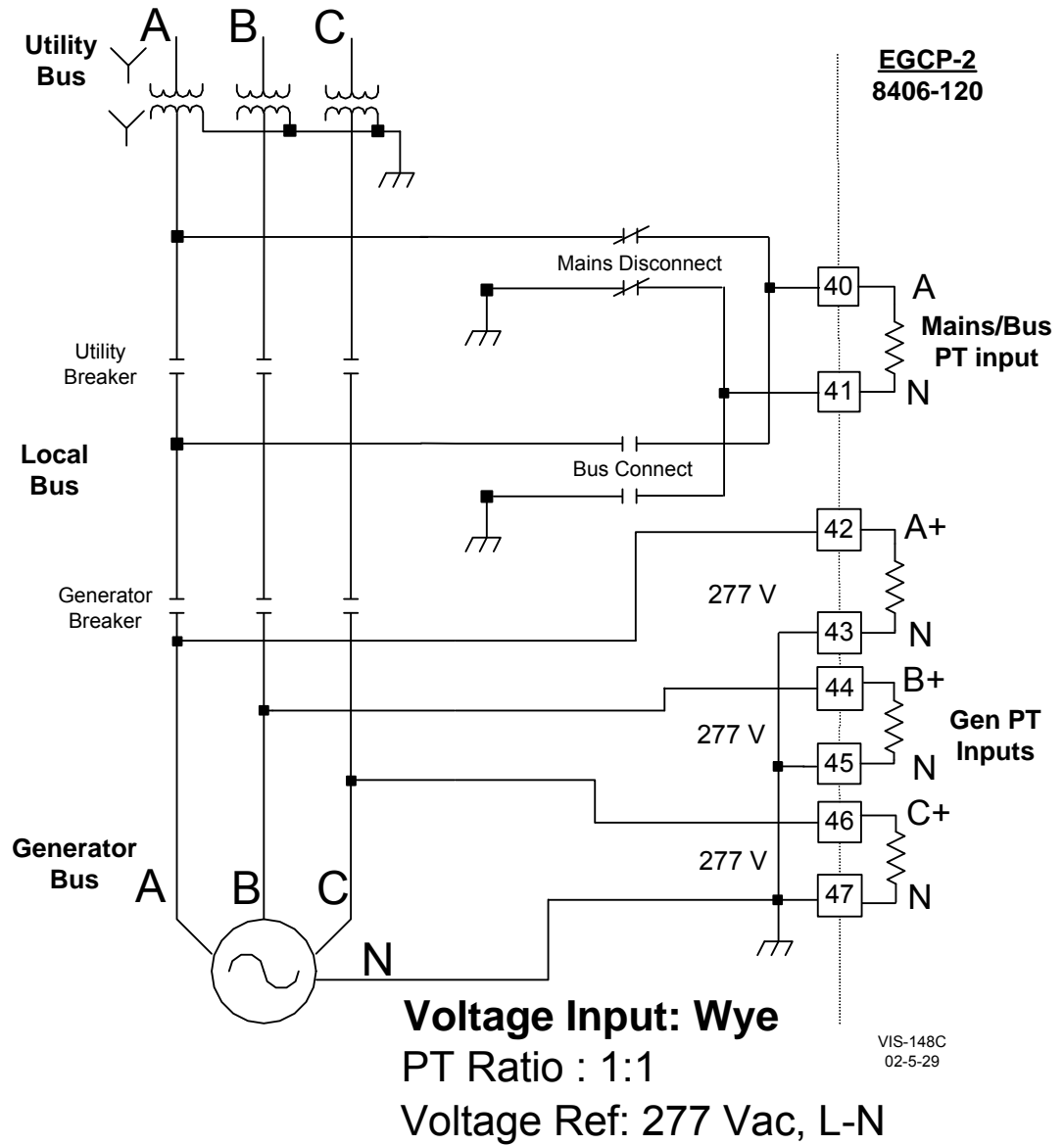

Figure 3-10b. PT Wiring Relationships for Generator, Bus, and Utility Inputs

Please Note:

1. This drawing shows EGCP-2 part number 8406-120.
2. Follow Utility/Local Bus PT wiring.

Current Transformer (CT) Inputs

Current Transformers (CTs) are utilized with the EGCP-2 control to allow high currents to be stepped down to a safe level for the EGCP-2 input circuitry. The EGCP-2 senses generator current via external current transformers. The “Amps per phase” display on the Generator Status screen:

1. does not display negative current
2. Must register at least 0.2 A on CT input before displaying any current

Refer to Figure 3-11 for CT input wiring schematic.

Current Transformer Input Ratings

For optimum control, the Current Transformers (CTs) should be sized at 100 to 125% of the generators rated current.

Example 1:

Generator rated for 2000 amps per phase at 100% load, rated power factor.

| | CT Ratio | |
|------|-----------------|---|
| 100% | 2000:5 | the EGCP-2 will see 5 amps at 2000 generator amps |
| 125% | 2500:5 | the EGCP-2 will see 4 amps at 2000 generator amps |

Example 2:

Generator rated for 150 amps per phase at 100% load, rated power factor.

| | CT Ratio | |
|------|-----------------|--|
| 100% | 150:5 | the EGCP-2 will see 5 amps at 150 generator amps |
| 125% | 188:5 | the EGCP-2 will see 4 amps at 150 generator amps |

Current Transformer Input Ratings

| | |
|--------------------------|----------------------|
| Number of Inputs: | 3 Generator CTs |
| Nominal Current Ratings: | 0–5 A rms |
| Maximum Current Rating: | 7 A rms for 1 minute |
| Input Burden: | 1.25 VA |
| Input Frequency Range: | 40–70 Hz |

NOTICE When conducting external Protective Relay testing, if the EGCP-2 CT inputs could measure greater than 7 A rms, *bypass the EGCP-2 CT inputs.*

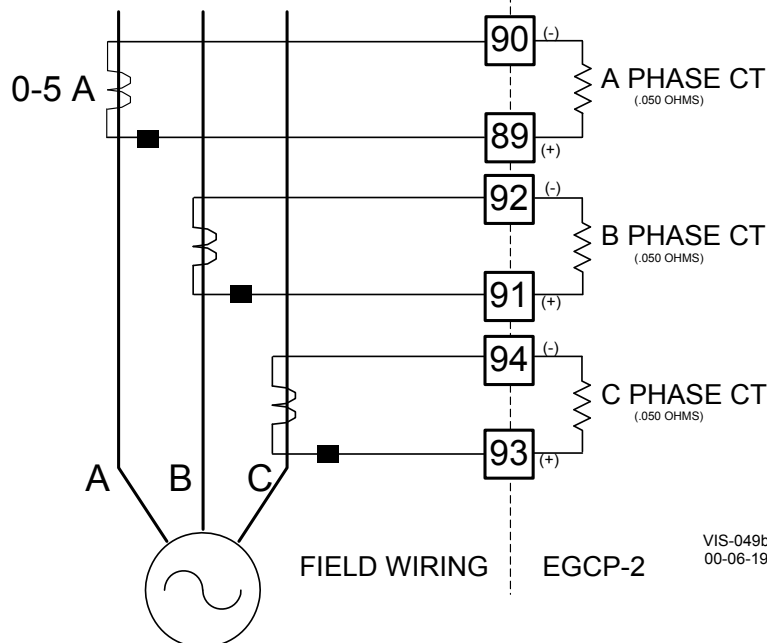

Figure 3-11. Current Transfer Wiring Diagram for EGCP-2

MPU (Speed) Input

To sense engine speed, the control accepts signals from one passive magnetic pickup unit (MPU) mounted off of a gear, which is connected or coupled to the engine's main shaft.

A passive MPU provides a frequency output signal corresponding to engine speed by sensing the movement of a gear's teeth past the MPU's pole piece. The closer the MPU's pole piece is to a gear's teeth and the faster the gear turns the higher a passive MPU's output amplitude will be. The EGCP-2 must sense an MPU voltage of 3.5 to 25 Vrms for proper operation.

MPU Input Ratings

Normal Frequency Range: 100–10 000 Hz @ 3.5 to 25 Vrms
Input impedance: 15 000 Ω

With proper MPU, gear size, and MPU-to-gear clearance, speed measurement should be capable down to 100 Hz. Standard MPU clearance is recommended to be 0.010" to 0.040" from tooth face to pole piece. For information on selecting the correct MPU or gear size please refer to Woodward manual 82510. See Figure 3-13 for wiring schematic.

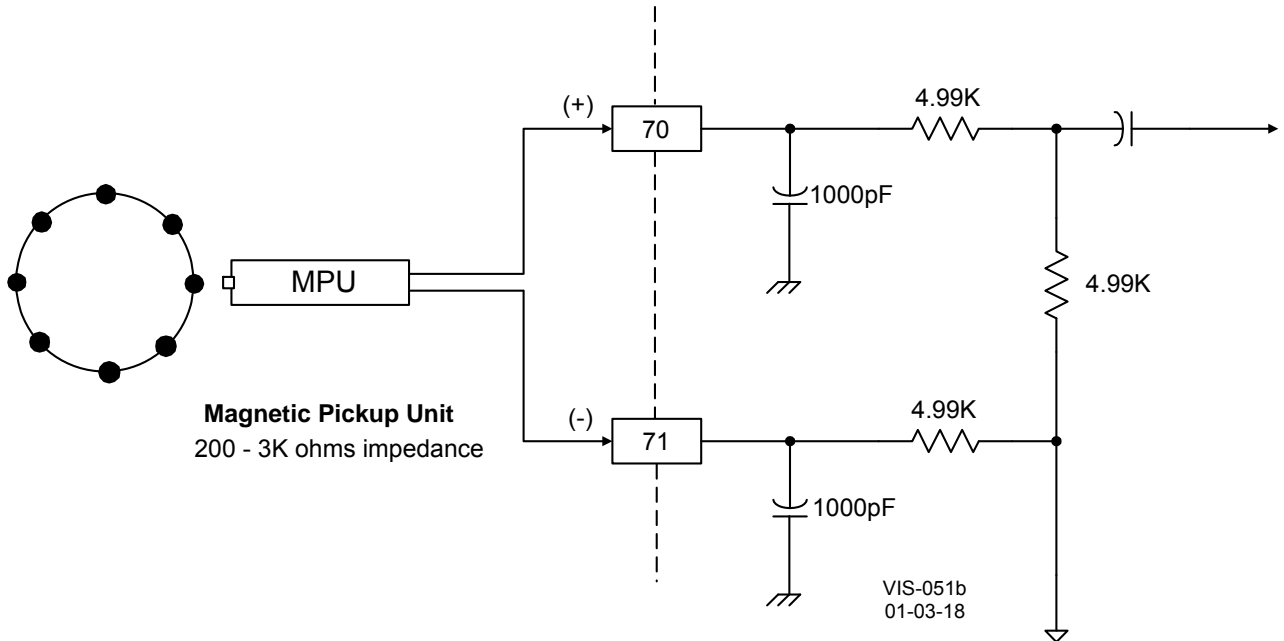

Figure 3-12. Wiring Diagram for MPU Input

Process Import/Export Input

The EGCP-2 control can be configured to control any process that is determined or affected by generator load. The Process Import/Export input is used by the EGCP-2 control to sense the process level being controlled. This input can be DIP switch, switch 4, configured to accept either a 4–20 mA or 1–5 Vdc signal. Refer to Figure 3-4 for DIP switch location.

Process Input Ratings

Loop Voltage Source: External (4–20 mA), External (1–5 Vdc)
 Input Impedance: 249 Ω (4–20 mA), 30 000 Ω (1–5 Vdc)

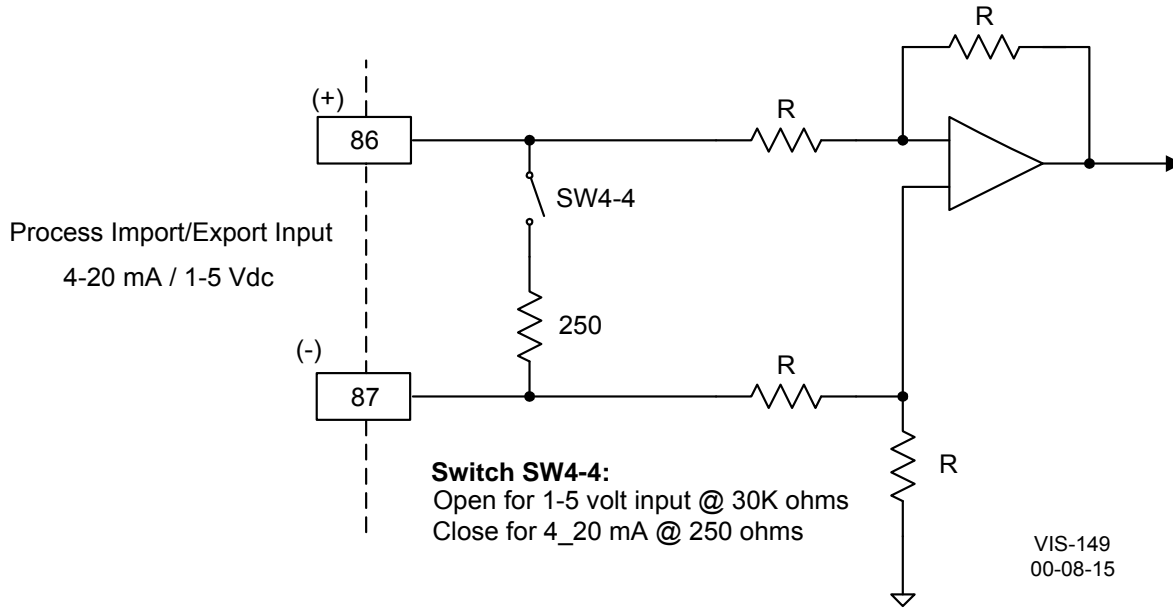

Figure 3-13a. Wiring Diagram for Process Import/Export Input

When connecting a kW transducer signal to multiple EGCP-2s, Woodward recommends converting the 4–12–20 mA signal to a 1–3–5 Vdc signal by connecting a 250 Ω resistor across the output of the kW transducer. The Vdc signal can then be paralleled to all EGCP-2 controls.

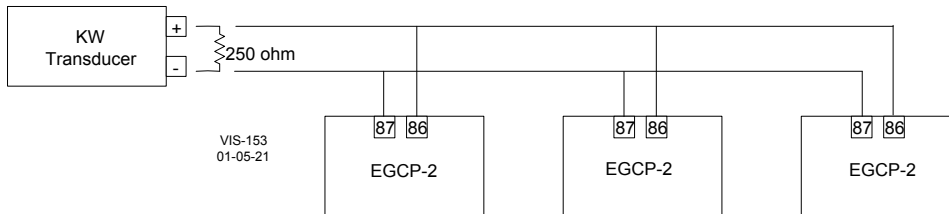
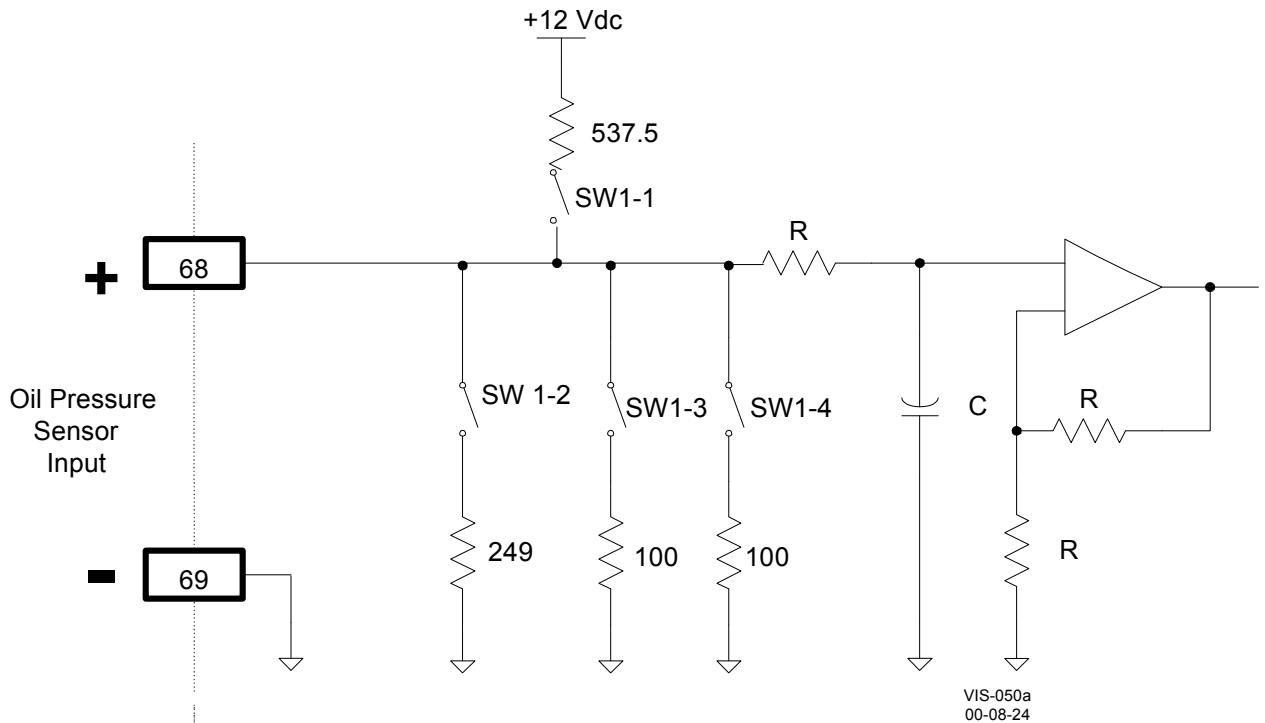

Figure 3-13b. Connecting a kW Transducer Signal to Multiple EGCP-2s (switch 4-4 is in the OPEN position)

Coolant Temperature and Oil Pressure Inputs

The EGCP-2 has one analog input dedicated to sense engine coolant temperature and one analog input dedicated to sense engine oil pressure. These inputs can be utilized for monitoring, alarm, and shutdown. Configurable alarm set points are provided for both a high and low alarms. Either one or both of these inputs can also be disabled if they are not to be used, by setting the related alarm set point to “Disabled.”

The inputs are designed to accept one of three types of signals: 4-20 mA, 1-5 V, or a passive resistive sensor. DIP switches on the control circuit board need to be configured for the type of sensor being used (see Figures 3-14 and 3-15). Once the sensor type is selected and the DIP switches are set, the inputs should be calibrated for proper monitoring. Each input has an associated Gain and Offset setting in the Calibration menu. The controls are calibrated at the factory for a 4–20 mA sensor type that represents a **0–75 psi pressure signal** and a **0–300 °F temperature signal**. If a different range 4–20 mA, 1–5 V, or passive resistive sensor is used, the Gain and Offset values will need to be adjusted.



| Input | 4-20mA | 1-5 Volt | 200 Ohm Sensor |
|-------|--------|----------|----------------|
| SW1-1 | Open | Open | Closed |
| SW1-2 | Closed | Open | X |
| SW1-3 | Open | Open | X |
| SW1-4 | Open | Open | X |

X - May be closed to insert shunt resistors required to make certain 0-200 ohm sensors more linear.

Figure 3-14. Wiring Diagram for Pressure Inputs

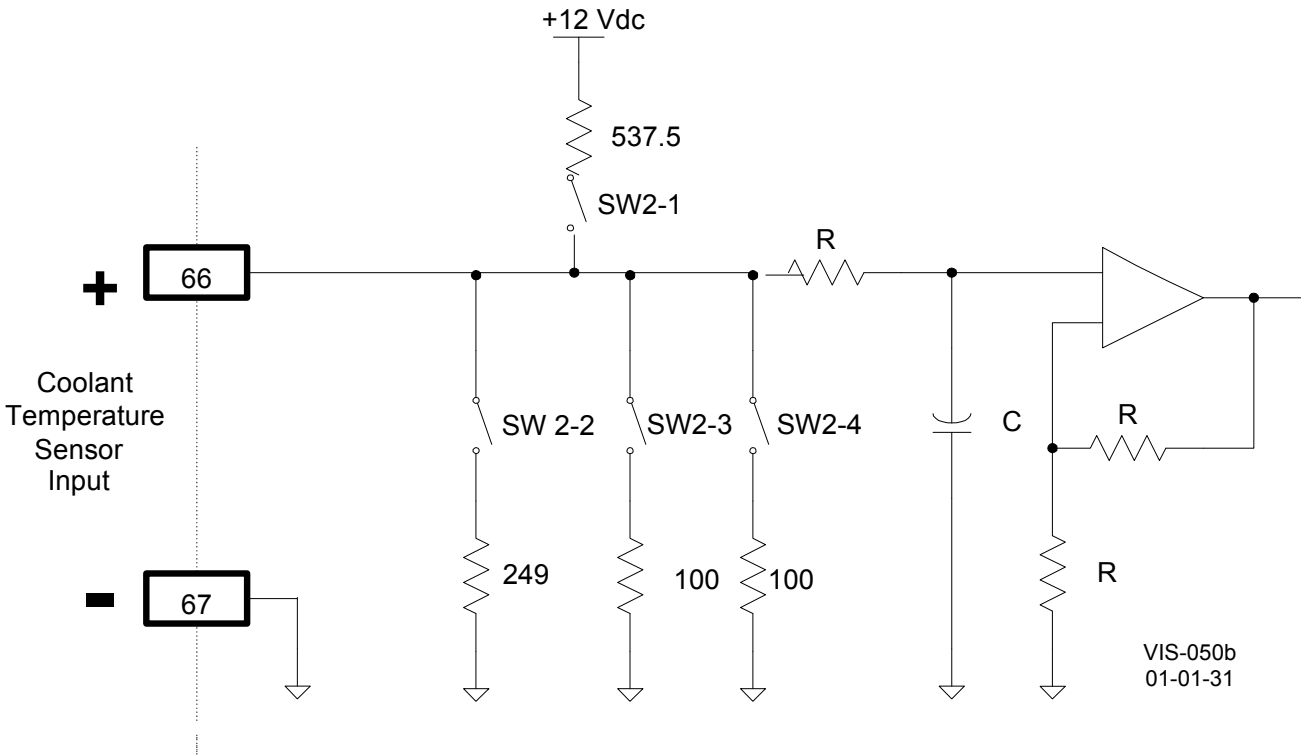

| Input | 4-20mA | 1-5 Volt | 200 Ohm Sensor |
|-------|--------|----------|----------------|
| SW2-1 | Open | Open | Closed |
| SW2-2 | Closed | Open | X |
| SW2-3 | Open | Open | X |
| SW2-4 | Open | Open | X |

X - May be closed to insert shunt resistors required to make certain 0-200 ohm sensors more linear.

Figure 3-15. Wiring Diagram for Temperature Inputs

When selected for resistive sensor, three additional shunt resistors are provided to match the impedance range of the given sensor, to provide more range and accuracy.

These inputs are designed to work with a variety of manufacturer's sensors. Sensors can have a Direct or Indirect relationship.

- **Direct**—Increase in Resistance, mA, or volts is an Increase in Pressure or Temperature.
- **Indirect**—Increase in Resistance, mA, or volts is a Decrease in Pressure or Temperature.

You must verify how the sensor functions so you can calibrate correctly. The Calibration menu explains adjusting the Gain and Offset for the different sensors.

Suggested Supplier

Water Temperature Sensor VDO 323-xxx 0-250 deg. F.(Indirect)
 Oil Pressure Sensor VDO 360-xxx 0-80 psi (Direct)

Here is an example using a **passive resistive type** sensor.

What you need to know:

1. Direct or Indirect type
 - o Direct – Increase in resistance is an Increase in Pressure
 - o Indirect – Increase in resistance is a Decrease in Pressure
2. Resistance value at High and Low Pressure or Temperature settings wanted
3. Example: VDO Temperature sender - # 323-477
 - a. 0—250 °F, 1/4 - 18NPT
 - b. Indirect type**
 - c. Resistance at 200 °F = 48 Ω
 - d. Resistance at 80 °F = 506 Ω
4. Other VDO # 323 -XXX will react the same as this sender
5. DIP Switch # 2
 - a. Close switch 1, because of resistive sender
 - b. Close switch 2, Shunt resistor due to resistance range going over 500 Ω
6. Connect 1 kΩ, 10 turn, 1 W potentiometer across terminals 66(+) and 67(-)
 - a. Set for 48 Ω
 - b. Calibration Menu
 - i. Adjust Water Temp **Gain** for 200 °F reading
 - c. Set potentiometer for 506 Ω
 - d. Calibration Menu
 - i. Adjust Water Temp **Offset** for 80 °F reading
 - e. Repeat steps a–d until no more adjustment is needed
7. Disconnect potentiometer and connect VDO Water Temperature Sender
 - a. This is a 2 wire sender (323-477)
 - i. This is not a polarity sensitive connection. The 2 wires coming from the sender should only connect to the EGCP-2 control.
 - b. If you are using a different VDO sender (323-XXX) that is only a 1 wire sender:
 - i. Connect the 1 wire to terminal 66(+)
 - ii. Terminal 67(-) must be connected to the case ground of the sender. This is commonly Battery Negative.
8. You need a temperature gauge on the engine to do the final calibration.
9. Start the engine and let stabilize at operating temperature.
10. Compare the Water Temperature reading on the EGCP-2 to the Temperature gauge on the engine.
11. If they do not read within ±2 degrees, In the Calibration menu adjust the Water Temperature Gain until the readings agree. Always press the ENTER key to save the new value.

Temperature and Pressure Input Ratings

| | |
|----------------------|------------------|
| Number of Channels: | 2 |
| Loop Voltage Source: | Internal |
| Input Impedance: | Switch Dependant |

Configuration menu (Items Affected)

1. None

Calibration menu

1. Oil Pressure Gain
2. Oil Pressure Offset
3. Water Temp Gain
4. Water Temp Offset

Speed Bias and Voltage Bias Outputs

The EGCP-2's Speed Bias output is a dedicated analog output, which is used to bias the prime mover's speed control for unit synchronization and load control. The Speed Bias output is software configurable for outputs of ± 3 Vdc, 0.5–4.5 Vdc, or 500 Hz PWM.

± 3 Vdc—Compatible with Woodward analog and digital speed Controls via the Aux Inputs or the load sharing lines on the 2301/2301A LSSC.

0.5–4.5 Vdc—Compatible with the Detroit Diesel Corp. DDEC-III and IV Control and Caterpillar's Gas Engine Control Module (GECM).

500 Hz PWM—Compatible with Caterpillar's ADEM control (diesel engine).

Refer to **Appendix B** of this manual for control specific speed bias connections.

The EGCP-2's Voltage Bias output is a dedicated analog output, which is used to bias the generator's automatic voltage regulator for unit synchronization and reactive load control. The Voltage Bias output is software configurable for outputs of ± 1 Vdc, ± 3 Vdc, or ± 9 Vdc.

The voltage bias output works with many automatic voltage regulators. Following is a list of manufacturers and types:

| Basler | Caterpillar | KATO | Newage | Leroy Somer | Marathon |
|--------|-------------|-----------|--------|-------------|----------|
| SR4A | VR3 | 360 | MX321 | R438 | DVR2000E |
| SR8A | Digital VR | 760 | MX341 | R448 | |
| SSE | VR6 | K65-12B | MA325 | R449 | |
| SSR | CDVR | K-125-10B | | | |
| DECS | | | | | |
| AVC | | | | | |

Appendix C shows connections and adjustment procedures for some of these regulators. The regulators listed are examples of some of the more common regulators. There are always new regulators being introduced in the market and you should use these drawings as examples of possible connection scenarios.

A common connection is an Accessory or Auxiliary input. This input takes a dc voltage, ± 1 Vdc is common, to change the rated voltage of the generator by $\pm 10\%$. So with any new regulator, check the specifications if this type input is available. An example is the Basler SSR regulator, see connection diagram in Appendix C.

The EGCP-2 only provides an analog, \pm Vdc output and will not function with any regulator that accepts discrete inputs only. An example of this is the Marathon 2000 DVR.

The Speed and Voltage Bias Outputs will only drive into high impedance type inputs, and are limited to inputs, which have an input impedance of 1000 Ω or more.

Speed and Voltage Bias Output Ratings

Number of Channels: 2
 Min Drive Impedance: 1000 Ω

Configuration menu (Items Affected)

1. Speed Bias Type
2. Voltage Bias Type

Calibration menu

1. Speed Bias Offset
2. Volts Bias Offset

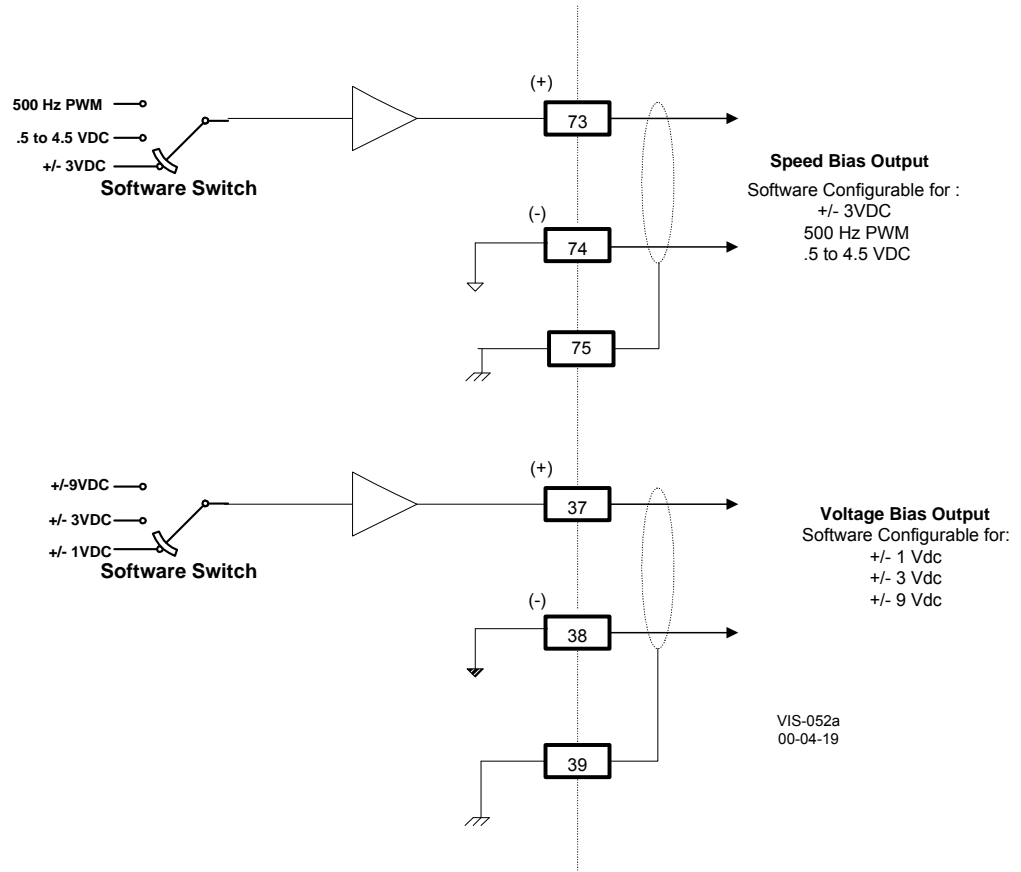

Figure 3-16. Wiring Diagram for Speed Bias and Voltage Bias Outputs

Discrete Inputs

NOTICE

Do NOT apply external power to the Discrete Inputs. The application of an external voltage to terminal 65 will result in permanent damage to the control.

Discrete inputs are used by the EGCP-2 control to determine breaker positions and accept external control commands. Contacts must change state for a minimum of 40 milliseconds for the control to sense and register a change in state. All discrete inputs accept dry contacts only, with contact wetting voltage provided by the EGCP-2 control. The following is a list of the available EGCP-2 Discrete Inputs:

| ID # | Description |
|--------|---------------------------------------|
| 1. | Automatic Mode Select |
| 2. | Test Engine Mode Select |
| 3. | Run with Load Mode Select |
| 4. | Voltage Raise |
| 5. | Voltage Lower |
| 6. | Speed/Load Raise |
| 7. | Speed/Load Lower |
| 8. | Generator Breaker Aux Contact |
| 9. | Utility (Mains) Breaker Aux Contact |
| 10. | Process I/E Mode Select |
| 11–16. | Configurable Alarm or Shutdown Inputs |

Discrete Input Ratings

| | |
|------------------------|--------------------|
| Number of Channels: | 16 |
| Input Type: | Optically isolated |
| Min Closed Sense Time: | 40 ms |

Speed/Load Raise and Lower Inputs

The Speed/Load Raise and Lower inputs change based on the control mode of the EGCP-2. If the EGCP-2 control is in the Speed control mode (generator breaker open), these contact inputs can be used to raise and lower speed. If the EGCP-2 control is in the Baseload control mode (generator breaker closed, utility tie breaker closed), these contact inputs can be used to raise and lower unit baseload. If the EGCP-2 control is in the Process control mode (Process control enabled), these contact inputs can be used to raise and lower the process set point. If the EGCP-2 control is in the isochronous load sharing mode, the Speed Raise and Lower inputs are disabled.

Voltage Raise and Lower Inputs

The Voltage Raise and Lower inputs change based on the control mode of the EGCP-2. If the EGCP-2 control is in the Speed control mode (generator breaker open), these contact inputs can be used to raise and lower unit voltage. If the EGCP-2 control is in the VAR control mode (VAR control programmed, generator breaker closed, utility tie breaker closed), these contact inputs can be used to raise and lower unit VARs. If the EGCP-2 control is in the Power Factor control mode (Power Factor control programmed, generator breaker closed, utility tie breaker closed), these contact inputs can be used to raise and lower unit Power Factor. If the EGCP-2 control is in the isochronous load sharing mode, the Voltage Raise and Lower inputs are disabled.

Gen, Tie, Alarm, and Shutdown Inputs

The Generator Breaker contact input must be wired so it is closed when the generator breaker is closed.

The Utility Tie Breaker contact input must be wired so it is closed when the utility tie breaker is closed.

The Configurable Alarm or Shutdown Inputs must be wired so they are closed when the alarm or shutdown condition is true.

Typical Example of Discrete Input (Auto/Manual Contact (DI#1) Input Shown)

Note:
TB6-65 is the discrete input common for
all contact inputs

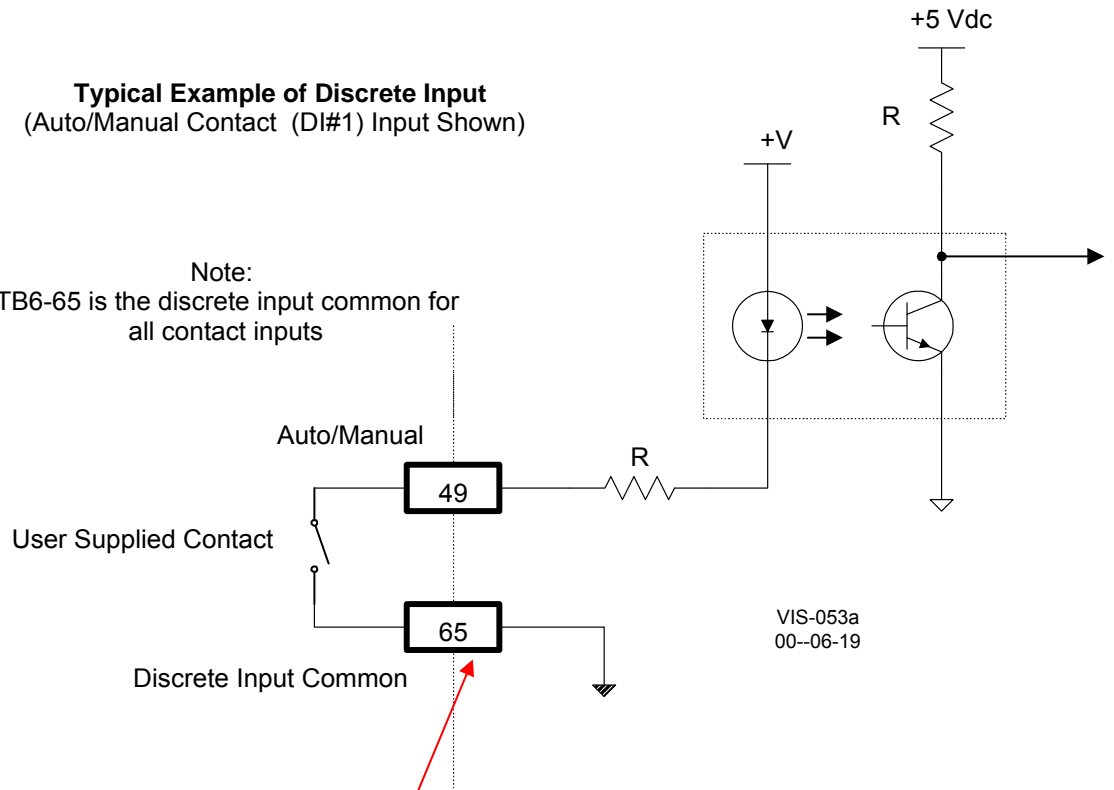

NOTICE

Do NOT apply external power to the Discrete Inputs. The application of an external voltage to terminal 65 will result in permanent damage to the control.

Figure 3-17. Wiring Diagram for Typical Discrete I/O Connections

Relay Outputs

Twelve (Form C type) Relay Outputs are used by the EGCP-2 control to interface with system devices. Before installation verify that the EGCP-2's relay contacts meet the power requirements of the circuit with which it is being interfaced. Interposing relays are required in cases where the interfaced circuit demands relay contacts with a higher power rating. If interposing relays are required, it is recommended that interposing relays with surge (inductive kick-back) protection be used. The following is a list of the available EGCP-2 Relay Outputs:

| ID# | Description |
|-----|---|
| 1. | Mains (Utility) Breaker Close/Contactor Close |
| 2. | Gen Breaker/Contactor Close |
| 3. | Engine Preglow |
| 4. | Fuel Solenoid |
| 5. | Engine Crank |
| 6. | Visual Alarm Relay |

7. Local Bus PT Connect
8. Utility (Mains) PT Disconnect
9. Utility (Mains) Breaker Trip (open)
10. Gen Breaker Trip (open)
11. Audible Alarm
12. Idle/Rated or kVA Load Switch

Relay Output Ratings

| | |
|------------------------|---|
| Number of Channels: | 12 |
| Relay Type: | Sealed |
| Relay Response Time: | 15 ms (operate and release) |
| Relay Life Expectancy: | ≥50 000 operations @ rated load (8 A @ 250 Vac COS ≥0.7) (8 A @ 24 Vdc τ ≥0.7 ms) |
| Replaceability: | Relays are soldered to main board and are not field replaceable |
| Max. Contact Ratings: | |
| AC: | 10 A, 250 Vac Resistive 249 W (1/3 hp), 125 Vac (7.2 A, 0.4–0.5 PF) |
| DC: | 10 A, 30 Vdc Resistive |

Relay Output Functions

Discrete Output #1—Mains Utility Breaker Close

With the relay de-energized, this output has Normally Open (NO), terminals 5 and 6, and Normally Closed (NC), terminals 6 and 7, contacts to select from.

The “Mains (utility) Breaker Close” relay output is utilized by the EGCP-2 to command the Mains (utility) Breaker to close. This output is configured for use with a BREAKER or a CONTACTOR in the Configuration menu under “CKT Breaker Control”. Every EGCP-2 that has the capability of being a MASTER unit must have this relay wired into the Mains (utility) Breaker close circuitry.

Breaker

When in the Breaker configuration, the EGCP-2 will ENERGIZE (momentary) to close the Mains (utility) Breaker. The ENERGIZE time is determined by the “CB Hold Time” in the Synchronizer menu. Discrete Output #9 is used to open the mains breaker.

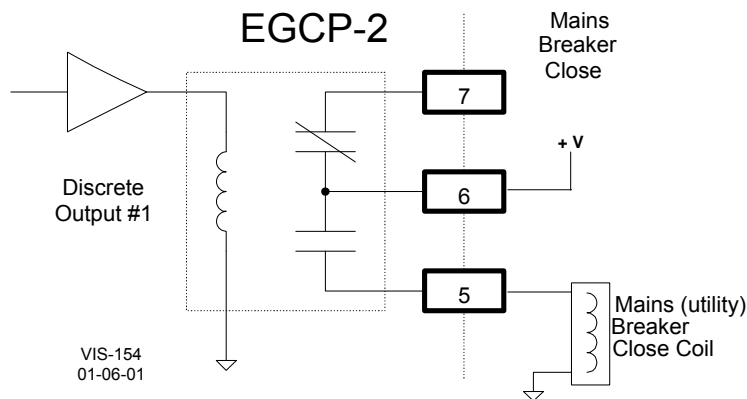

Figure 3-18. Example of the Mains Breaker NO Output Connected to Close the Mains (Utility) Breaker (ENERGIZE TO CLOSE)

Contactor

The “Mains Breaker Close” output is used to close and open the Mains Contactor. The “Mains Breaker Trip”, discrete output #10 is NOT used in the Contactor mode.

The EGCP-2 will **DE-ENERGIZE (continuously) to close the Mains Contactor** and **ENERGIZE (continuously) to open the Mains Contactor**. This is reverse logic from the Generator Contactor Close, discrete output # 2. External logic will be needed to verify the contactors state when installing or replacing EGCP-2 controls and for multiple control systems.

NOTICE

When power is removed from the EGCP-2, the “Mains Breaker Close” output will be in the De-energized state and attempt to close the Mains contactor.

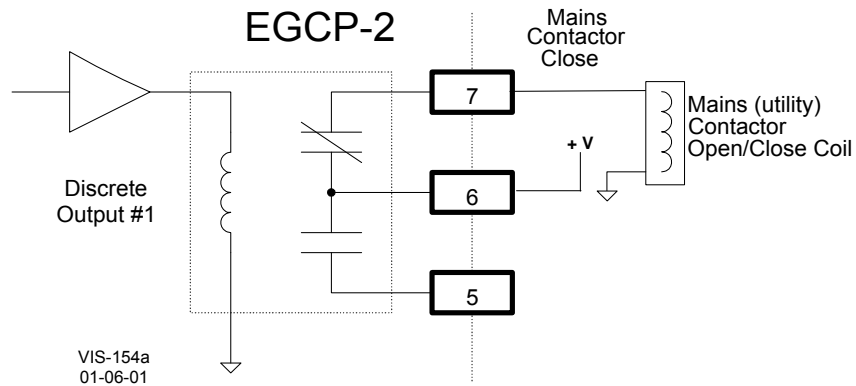

Figure 3-19. Example Using the NC Output to Control the Mains (Utility) Contactor (ENERGIZE TO OPEN)

Discrete Output #2—Generator Breaker Close

With the relay de-energized, this output has Normally Open (NO), terminals 8 and 9, and Normally Closed (NC), terminals 9 and 10, contacts to select from.

The “Generator Breaker Close” relay output is utilized by the EGCP-2 to command the Generator Circuit breaker to close. This output is configured for use with a BREAKER or a CONTACTOR in the Configuration menu under “CKT Breaker Control”.

Breaker

When in the Breaker configuration, the EGCP-2 will ENERGIZE (momentary) to close the Generators Breaker. The ENERGIZE time is determined by the “CB Hold Time” in the Synchronizer menu. Discrete Output #10 is used to open the generators breaker.

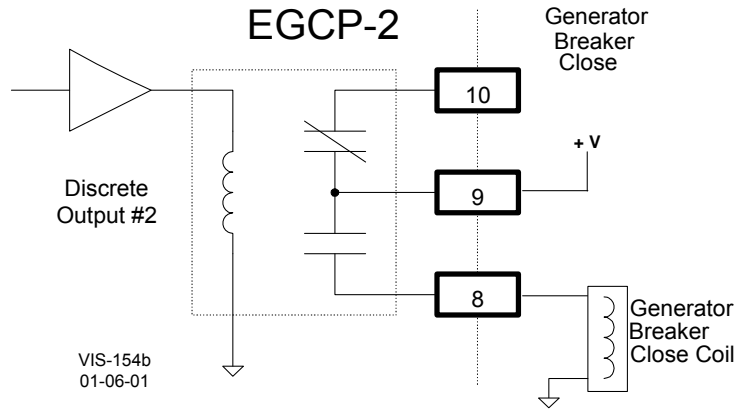

Figure 3-20. Example of the Generator Breaker Close NO Output Connected to Close the Generator Breaker (ENERGIZE TO CLOSE)

Contactor

The “Generator Breaker Close” output is used to close and open the Generators Contactor. The “Generator Breaker Trip”, discrete output #10, is NOT used in the Contactor mode.

The EGCP-2 will DE-ENERGIZE (continuously) to open the Generators Contactor and ENERGIZE (continuously) to close the Generators Contactor. This is reverse logic from the Mains Contactor Close, discrete output # 1.

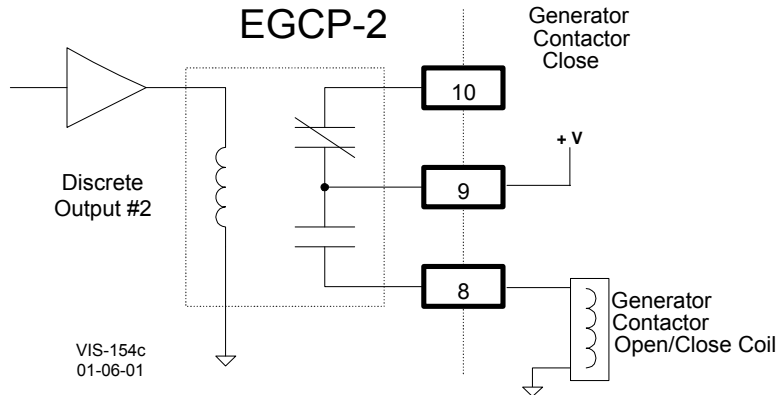

Figure 3-21. Example Using the NO Contacts to Control the Generator’s Contactor (ENERGIZE TO CLOSE)

Discrete Output #3—Engine Preglow

The “Engine Preglow” relay output utilizes a set of normally open (NO) contacts on terminals 11 and 12.

The “Engine Preglow” relay output is utilized by the EGCP-2 to turn on a diesel engine’s glow plugs, if so equipped. This relay will energize for a programmed length of time, based on the “Preglow Time” setting, before an engine crank command is given.

Discrete Output #4—Fuel Solenoid

The “Fuel Solenoid” relay output utilizes a set of Normally Open (NO) contacts on terminals 13 and 14 to energize the engine’s fuel solenoid.

The Configurations menu, “Start Sequencing” setting of Enabled or Disabled, determines the EGCP-2’s start process.

Start Sequencing—Enabled

This relay ENERGIZES at the same time an Engine Crank command is initiated, and stays on until a shutdown command is received. The EGCP-2 must have a Magnetic Pickup (MPU) signal to operate in this condition.

Start Sequencing—Disabled

The EGCP-2 will ENERGIZE (continuously) the Fuel Solenoid relay when a start command is given. It will De-energize when a shutdown command is received. The fuel solenoids output will function as a Run/Stop relay.

There is no “Engine Preglow” or “Engine Crank” command in this mode. The Disabled mode allows the EGCP-2 to operate without a Magnetic Pickup (MPU) signal.

Discrete Output #5—Engine Crank

The “Engine Crank” relay output utilizes a set of Normally Open (NO) contacts on terminals 15 and 16.

The “Engine Crank” relay output is utilized by the EGCP-2 to command the engine to crank or start. This relay will energize for a programmed length of time, based on the “Crank Time” setting, or until engine speed is sensed to be above the “Crank Cutout” speed setting.

Discrete Output #6—Visual Alarm

With the relay de-energized, this output has Normally Open (NO) terminals 18 and 19 and Normally Closed (NC) terminals 19 and 20 contacts to select from.

The “Visual Alarm” relay output can be utilized as an option to remotely indicate when an alarm condition has been sensed by the EGCP-2 control. This relay energizes upon any sensed alarm condition and will remain energized until all alarm conditions have been acknowledged or committed via the unit’s Alarm Screen. Refer to chapter 2 for information on acknowledging and committing alarms.

Discrete Output #7—Local Bus PT Connect

The “Local Bus PT Connect” relay utilizes a set of Normally Open (NO) contacts on terminals 21 and 22.

The “Local Bus PT connect” relay output is utilized by the EGCP-2 to connect the Local Bus PT to the EGCP-2’s “Utility and Local Bus PT Input” on terminals 40 and 41. Due to relay load limitations, it is required that this output be configured to drive an interposing relay with which to control the Local Bus PT connection. Refer to Figures 3-7 and 3-8 of this chapter for detailed wiring information. This type of relay configuration allows a break-before-make action, insuring that the Utility Tie PT and the Local Bus PT are never connected.

Discrete Output #8—Utility Tie (Mains) PT Disconnect

The “Utility Tie (Mains) PT Disconnect” relay utilizes a set of Normally Open (NO) contacts on terminals 23 and 24.

The “Utility Tie (Mains) PT disconnect” relay output is utilized by the EGCP-2 to disconnect the Utility PT from the EGCP-2’s “Utility and Local Bus PT Input” on terminals 40 and 41. Due to relay load limitations, it is required that this output be configured to drive an interposing relay with which to control the Utility Tie PT connection. Refer to Figures 3-7 and 3-8 of this chapter for detailed wiring information. This type of relay configuration allows a break-before-make action, insuring that the Utility Tie PT and the Local Bus PT are never connected.

Discrete Output #9—Mains Breaker Trip (Open)

With the relay de-energized, this output has Normally Open (NO), terminals 25 and 26, and Normally Closed (NC), terminals 26 and 27, contacts to select from.

The “Mains Breaker Trip (open)” relay output is utilized by the EGCP-2 to command the Mains (utility) Breaker to open. This output is operational when configured for use with a BREAKER, in the Configuration menu under “CKT Breaker Control”. If configured for Contactor, see Discrete Output #1 for Mains Contactor open/close operation.

Every EGCP-2 that has the capability of being a MASTER unit must have this relay wired into the Mains (utility) Breaker open circuitry.

Breaker

When in the Breaker configuration, the EGCP-2 will ENERGIZE (momentary) to open the Mains (utility) Breaker.

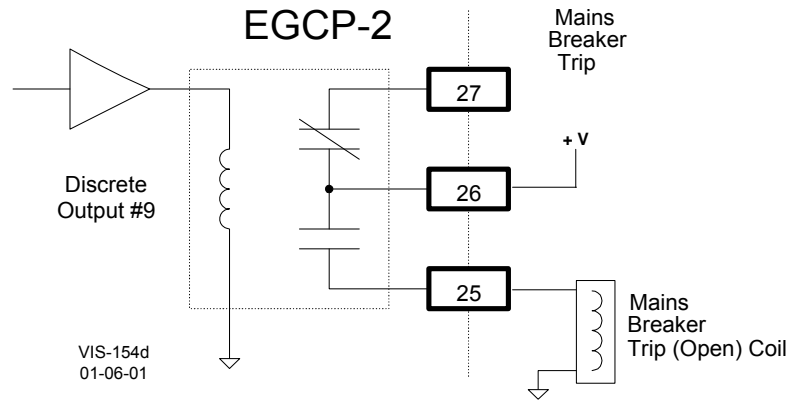

Figure 3-22. Example Using the NO Contacts to Control the Mains Breaker Trip (Open) Coil (ENERGIZE TO OPEN)

Discrete Output #10—Generator Breaker Trip (Open)

With the relay de-energized, this output has Normally Open (NO), terminals 28 and 29, and Normally Closed (NC), terminals 29 and 30, contacts to select from.

The “Generator Breaker Trip (open)” relay output is utilized by the EGCP-2 to command the Generator Breaker to open. The relay output will DE-ENERGIZE to open the Generator Breaker. This output is operational when configured for use with a BREAKER, in the Configuration menu under “CKT Breaker Control”. If configured for Contactor, see Discrete Output #2 for Generator Contactor open/close operation.

Breaker

In the Breaker configuration, the “Generator Breaker Trip (open)” relay will energize with the EGCP-2 in Auto or Manual modes:

Automatic Mode

1. In the “AUTO” mode (Discrete Input #1)
2. If a LOMs start is initiated
 - a. And the Generator is stable (Generator Stable Delay time has been achieved)
3. If the Run w/Load switch is closed
 - a. And the Generator is stable (Generator Stable time has been achieved)
4. The “Auto” with “Test” mode will NOT energize the “Generator Breaker Trip (open)” relay

Manual Mode

1. “Run w/Load” mode (Discrete Input #3)
 - a. And the Generator is stable (Generator Stable Delay time has been achieved)
2. “Test” mode will NOT energize the “Generator Breaker Trip (open)” relay

The EGCP-2 will DE-ENERGIZE to open the Generators Breaker. The output will stay de-energized until one of the two conditions is met.

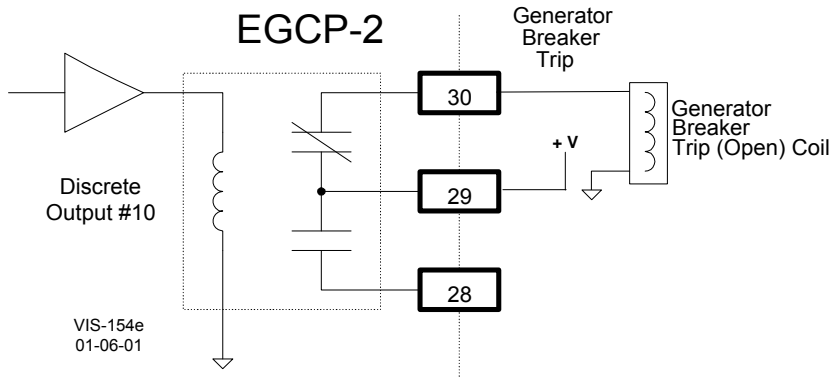

Figure 3-23. Example Using the NC Contacts to Control the Generator Breakers Open Coil (DE-ENERGIZE TO OPEN)

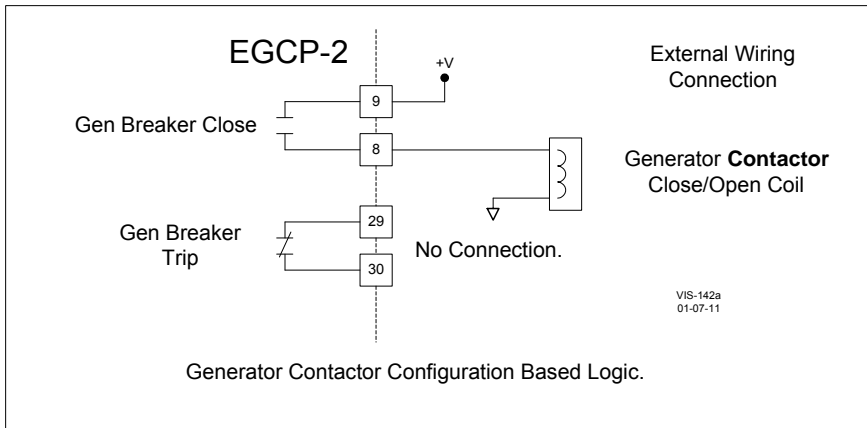
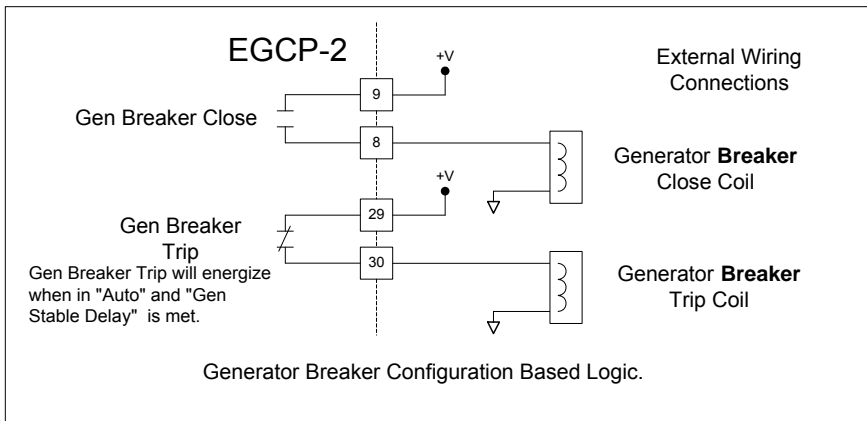

Figure 3-24. Generator Breaker and Contactor Close and Open Logic

Discrete Output #11—Audible Alarm

With the relay de-energized, this output has Normally Open (NO) terminals 31 and 32 and Normally Closed (NC) terminals 32 and 33 contacts to select from.

The “Audible Alarm” relay output can be utilized as an option to control a plant Alarm Horn to indicate when an alarm condition has been sensed by the EGCP-2 control. This relay energizes upon any sensed alarm condition and will remain energized until an acknowledged command is given. Refer to chapter 2 for information on acknowledging and committing alarms.

When an alarm set point is configured for Audible Alarm, the alarm condition will cause the audible and visual alarm output relays to energize and the red LED on the face of the EGCP-2 to flash. All alarm indicators will remain active until the alarm condition is acknowledged. No control actions occur as a result of an audible alarm condition.

Discrete Output #12—kVA Load or Idle/Rated Switch

This relay uses Normally Open (NO) contacts at terminal 34 and 35.

Discrete Output #12 can be configured for a “KVA Load” or an “Idle/Rated” switch. This selection is done in the Configuration menu under “Relay #12 Function”.

KVA Load Switch

This relay will energize when the controls kVA value is within the configured Low and High settings. The relay will de-energize when the kVA value is below or above the configured Low and High settings. The low and high set points are configured in the Real Load Control menu, under items “kVA Switch Low” and “kVA Switch High”.

Idle/Rated Switch

When selected as an Idle/Rated switch, the output must be connected to the engines speed control. This relay is de-energized to select an idle speed settings, and after reaching the set idle speed value and holding at that point for the set amount of time, the relay energizes to select the speed controls rated speed setting. The speed value and time are configured in the Engine Control menu under items “Idle Speed” and “Idle Time”.

The engines idle speed must be equal to or greater than the configured “Idle Speed” value to start the “Idle Time”. The EGCP-2 uses the magnetic pickup (MPU) signal to calculate the idle speed. If no MPU is connected, the idle speed is calculated from the Generators frequency. Remember, if the generator is NOT excited at idle speed and there is no MPU signal, the Idle/Rated switch will not energize.

When a Loss of Mains (LOM) or an overloaded system condition exists, the idle/rated function is bypassed, and rated speed is selected during the start sequencing routine.

AC Inputs

The EGCP-2 receives ac inputs from the generator, bus, mains and engine. They are as follows:

| Location | Description | Signal | Burden |
|----------|-------------------------------|--------------|----------------|
| 42 | Generator PT phase A + | AC Voltage | 200 k Ω |
| 43 | Generator PT phase A – | AC Voltage | A+ to A– |
| 44 | Generator PT phase B + | AC Voltage | 200 k Ω |
| 45 | Generator PT phase B – | AC Voltage | B+ to B– |
| 46 | Generator PT phase C + | AC Voltage | 200 k Ω |
| 47 | Generator PT phase C – | AC Voltage | C+ to C– |
| 89 | Generator CT phase A+ Current | AC Current | 0.050 Ω |
| 90 | Generator CT phase A– Current | AC Current | + to – |
| 91 | Generator CT phase B+ Current | AC Current | 0.050 Ω |
| 92 | Generator CT phase B– Current | AC Current | + to – |
| 93 | Generator CT Phase C+ Current | AC Current | 0.050 Ω |
| 94 | Generator CT Phase C– Current | AC Current | + to – |
| 40 | Mains/Bus PT Phase A | AC Voltage | 200 k Ω |
| 41 | Mains/Bus PT Phase B or N | AC Voltage | + to – |
| 70 | Magnetic Pickup + | AC Frequency | 15 k Ω |
| 71 | Magnetic Pickup – | AC Frequency | + to – |
| 72 | Magnetic Pickup Shield | | |

DC Inputs and Outputs

| Location | Description | Signal | I/O |
|----------|-----------------------|------------------------|---|
| 1 | + power supply | 9–32 Vdc | Isolated |
| 2 | – power supply | | Input 13 W typical, 20 W max. |
| 86 | + Process Signal | 4–20 mA | Isolated Input |
| 87 | – Process Signal | or 1–5 Vdc | 249 Ω (4–20 mA) |
| 88 | Process Signal Shield | | 30 k Ω (1–5 Vdc) |
| 73 | + Speed Bias | \pm 3 Vdc, | Software Configured |
| 74 | – Speed Bias | 0.5 to 4.5 Vdc, | 10 mA Maximum |
| 75 | Speed Bias Shield | 500 Hz PWM | Isolated Output |
| 37 | + Voltage Bias | \pm 1, 3, or 9 Vdc | Software Configured |
| 38 | – Voltage Bias | | 10mA Maximum |
| 39 | Voltage Bias Shield | | Isolated Output |
| 68 | Pressure Sensor + | 0–200 Ω sensor, | Internal Voltage Source |
| 69 | Pressure Sensor – | 4–20 mA, or 1–5 Vdc | Internal Source Common Dip Switch Selected |
| 66 | Temp Sensor + | 0–200 Ω sensor | Internal Voltage Source |
| 67 | Temp Sensor – | 4–20 mA, or 1–5 Vdc | Internal Source Common Dip Switch Selected |

Discrete Inputs

| Loc. | Description | Signal | Input |
|------|---------------|------------------------|--------------------------------------|
| 49 | Auto | Discrete Input (DI-1) | – power supply (internal connection) |
| 50 | Test | Discrete Input (DI-2) | – power supply (internal connection) |
| 51 | Run/Ld | Discrete Input (DI-3) | – power supply (internal connection) |
| 52 | Volt Raise | Discrete Input (DI-4) | – power supply (internal connection) |
| 53 | Volt Lower | Discrete Input (DI-5) | – power supply (internal connection) |
| 54 | Speed Raise | Discrete Input (DI-6) | – power supply (internal connection) |
| 55 | Speed Lower | Discrete Input (DI-7) | – power supply (internal connection) |
| 56 | Gen CB Aux | Discrete Input (DI-8) | – power supply (internal connection) |
| 57 | Mains CB Aux | Discrete Input (DI-9) | – power supply (internal connection) |
| 58 | Process | Discrete Input (DI-10) | – power supply (internal connection) |
| 59 | Fault 1 | Discrete Input (DI-11) | – power supply (internal connection) |
| 60 | Fault 2 | Discrete Input (DI-12) | – power supply (internal connection) |
| 61 | Fault 3 | Discrete Input (DI-13) | – power supply (internal connection) |
| 62 | Fault 4 | Discrete Input (DI-14) | – power supply (internal connection) |
| 63 | Fault 5 | Discrete Input (DI-15) | – power supply (internal connection) |
| 64 | Fault 6 | Discrete Input (DI-16) | – power supply (internal connection) |
| 65 | Switch Common | Discrete Input | – power supply (internal connection) |

NOTE: Approximately 5 mA current draw across each DI when CLOSED.

Discrete Outputs

| Location | Description | Signal | Output Rating |
|----------|---------------------|---------------------------|----------------------------|
| 7 | Mains Brkr Close | NC Discrete Output (D01) | (see Relay Output Ratings) |
| 6 | Mains Brkr Close | C (D01) | “ |
| 5 | Mains Brkr Close | NO Discrete Output (D01) | “ |
| 10 | Gen Brkr Close | NC Discrete Output (D02) | “ |
| 9 | Gen Brkr Close | C (D02) | “ |
| 8 | Gen Brkr Close | NO Discrete Output (D02) | “ |
| 12 | Engine Preglow | C (D03) | “ |
| 11 | Engine Preglow | NO Discrete Output (D03) | “ |
| 14 | Fuel Solenoid | C (D04) | “ |
| 13 | Fuel Solenoid | NO Discrete Output (D04) | “ |
| 16 | Crank Engine | C Discrete Output (D05) | “ |
| 15 | Crank Engine | NO Discrete Output (D05) | “ |
| 17 | No Connection | Isolation Boundary | “ |
| 20 | Visual Alarm | NC Discrete Output (D06) | “ |
| 19 | Visual Alarm | C (D06) | “ |
| 18 | Visual Alarm | NO Discrete Output (D06) | “ |
| 22 | Bus PT Connect | C (D07) | “ |
| 21 | Bus PT Connect | NO Discrete Output (D07) | “ |
| 24 | Mains PT Disconnect | NC Discrete Output (D08) | “ |
| 23 | Mains PT Disconnect | C (D08) | “ |
| 27 | Mains Brkr Trip | NC Discrete Output (D09) | “ |
| 26 | Mains Brkr Trip | C (D09) | “ |
| 25 | Mains Brkr Trip | NO Discrete Output (D09) | “ |
| 30 | Gen Brkr Trip | NC Discrete Output (D010) | “ |
| 29 | Gen Brkr Trip | C (D010) | “ |
| 28 | Gen Brkr Trip | NO Discrete Output (D010) | “ |
| 33 | Audible Alarm | NC Discrete Output (D011) | “ |
| 32 | Audible Alarm | C Discrete Output (D011) | “ |
| 31 | Audible Alarm | NO Discrete Output (D011) | “ |

| Location | Description | Signal | Output Rating |
|----------|--------------------|---------------------------|---------------|
| 35 | Idle Rated/Load SW | C (DO12) | " |
| 34 | Idle Rated/Load SW | NO Discrete Output (DO12) | " |
| 36 | No Connection | Isolation Boundary | |

Communication Ports: RS-485 & RS-422 (1 each)

| Location | Description | Signal |
|----------|-------------------------|-------------------------------|
| 76 | + 485 Communication | Inter-control Communications |
| 77 | - 485 Communication | Inter-control Communications |
| 78 | 485 Shield | |
| 79 | Communication +5 Vdc | Inter-control connection only |
| 80 | Communication Reference | Inter-control connection only |
| 81 | 422 Communication RX+ | PC interface |
| 82 | 422 Communication RX- | PC interface |
| 83 | 422 Shield | |
| 84 | 422 Communication TX+ | PC interface |
| 85 | 422 Communication TX- | PC interface |

Specifications

Communications:

RS-422 protocol
 9600 Baud (fixed maximum)
 No Parity
 1 Stop Bit

Minimum Computer Requirements:

Windows 95

Hardware Connections

Once the software is installed on the computer hard drive, the hardware connection between the computer and the EGCP-2 control must be made for correct communication between the two devices. This hardware connection is completed using a direct cable connection between the computer and the EGCP-2 control(s) RS-422 network.

Modbus[®]/ServLink Communications

The laptop or desktop computer, which will be used with the EGCP-2 RS-422 port, will have a 9-pin serial port. This port is configured by the computer hardware to use a serial communications protocol called RS-232. The details of this protocol are not important to know for hardware connection to the EGCP-2 control(s), other than there is a need to convert the RS-232 protocol of the computer port to RS-422 protocol used by the EGCP-2 control network. This conversion is accomplished via an external conversion module, which takes the 9-pin RS-232 serial port input from the computer, and changes it to a RS-422 protocol for the EGCP-2. These converters can be found in most computer or electronics stores, and are called RS-232 to RS-422 Converters. Woodward offers a cable, 5417-551, which includes this converter. This cable is designed for point-to-point communications.

In a system with multiple (8 maximum) EGCP-2 controls, each control is interconnected to the others on the 422 network in a multi-drop fashion. The computer is linked to the network at any control as if it were the next control on the network, as shown below.

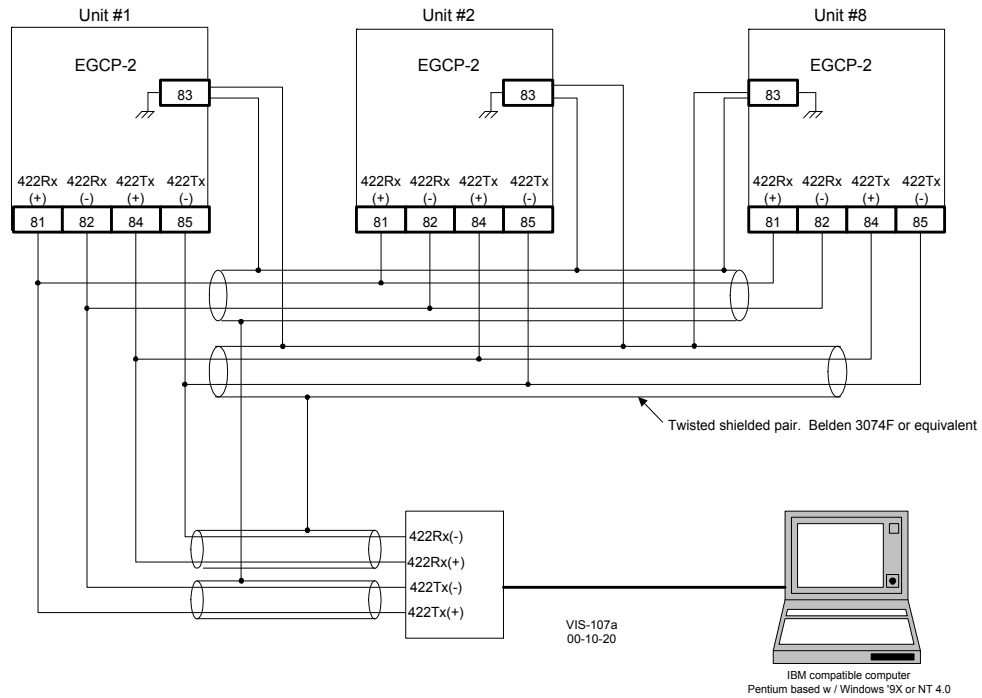

Figure 3-25. RS-422 Communications

Switch configuration for multiple units utilizing RS-422 communication.

| Unit #1 | Unit #2 | Unit #8 |
|--------------|------------|--------------|
| SW3-1 Closed | SW3-1 Open | SW3-1 Closed |
| SW3-2 Closed | SW3-2 Open | SW3-2 Closed |
| SW3-3 Closed | SW3-3 Open | SW3-3 Closed |

IMPORTANT

When the RS-422 to RS-232 converter is greater than 30 meters from unit 1, an isolating version will be required. Cable shields must also be AC coupled to earth or connected to RS-422 to RS-232 converter chassis. This chassis must be Isolated from earth and may be AC coupled to earth.

When unit 2 and/or unit 3 are more than 30 meters from unit 1, the cable shield must be ac coupled to terminal 83. The capacitor must be 0.01 μ F with a working voltage of 1000 Vdc or greater.

The RS-422 Termination switches, switch 3, must be closed on the end units on the network for proper communications. See Figure 3-4 for switch locations. Failure to terminate the network properly will cause communication drop out errors.

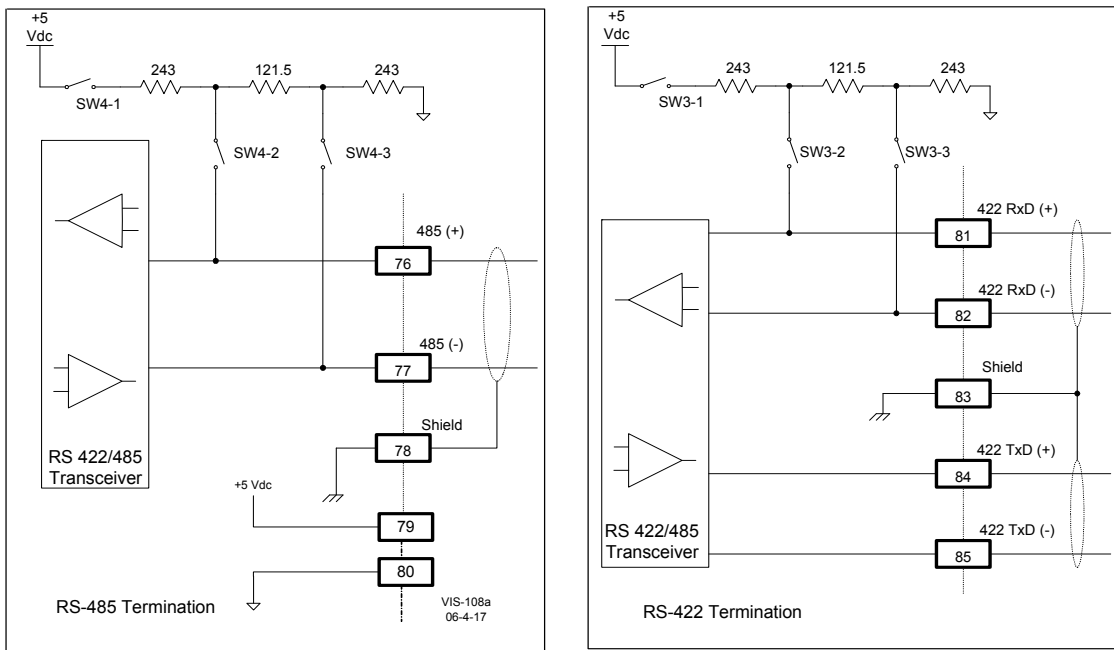

Figure 3-26. RS-485 and RS-422 Termination Diagrams

Inter-control Communications (RS-485 Network)

The EGCP-2 uses a proprietary communication structure to share information between multiple EGCP-2 controls. This structure allows accurate load sharing, status, and command messages to be exchanged between up to 8 controls. The network uses RS-485 protocol over a standard twisted shielded pair to link the EGCP-2 controls at terminals 76(+) and 77(-) with 78 the shield.

IMPORTANT

When EGCP-2 controls are installed with a distance of 1000 m or greater between them, additional measures should be taken to ensure solid communications. The wire gauge of the communications link should be upgraded to 0.5–0.8 mm² (18–20 AWG) where larger sizes are used for longer distances. The larger size wire will exhibit smaller voltage drop. If communications errors are observed, terminal 80 can be connected from control to control using 1.0 mm² (16 AWG) wiring. Making this connection will force all communications transceivers to the same reference.

As shown in Figure 3-26, the EGCP-2 uses Switch 4 (4-1, 4-2, and 4-3) to terminate the 485 network. Switches 4-1, 4-2, and 4-3 will be closed (pushed down toward the PC board, see Figure 3-4) for proper 485 network terminations. Proper network termination will ensure robust inter-control communications.

The information on the RS-485 network is for communications between controls only and must not be interfaced in any way with external devices. There is an RS-422 port on the EGCP-2, which is used to monitor and control the units remotely.

Example:

2 EGCP-2s—Both EGCP-2s must have the 485 network terminated.

3 or more EGCP-2s—

1. The end controls must have the 485 network terminated (see Figure 3-27).
2. Terminals 79 and 80 should be connected from control to control
 - a. This eliminates signal loss if one of the terminated controls is powered down.

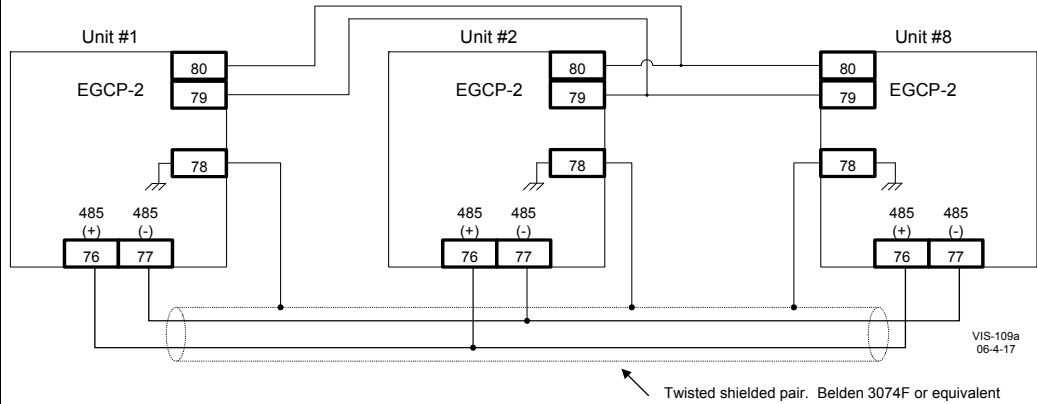

Figure 3-27. RS-485 Inter-Control Communications

Switch configuration for 2 units utilizing RS-485 communication.

| Unit #1 | Unit #2 |
|--------------|--------------|
| SW4-1 Closed | SW4-1 Closed |
| SW4-2 Closed | SW4-2 Closed |
| SW4-3 Closed | SW4-3 Closed |

Switch configuration for 3 or more units utilizing RS-485 communication.

| Unit #1 | Unit #2 | Unit #8 |
|--------------|------------|--------------|
| SW4-1 Closed | SW4-1 Open | SW4-1 Closed |
| SW4-2 Closed | SW4-2 Open | SW4-2 Closed |
| SW4-3 Closed | SW4-3 Open | SW4-3 Closed |

IMPORTANT

When unit 2 and/or unit 3 are more than 30 m from unit 1, the cable shield must be ac coupled to terminal 78. The capacitor must be 0.01 μ F with a working voltage of 1000 Vdc or greater.

Alarms and Shutdowns

The EGCP-2 has many alarm/shutdown set points, which can be configured for five different alarm/shutdown conditions. The five conditions are as follows:

Disabled

When an alarm set point is set for Disabled, the alarm condition will have no external indicators to signal the event has occurred. No control actions occur as a result of a disabled condition.

Warning

When an alarm set point is set for Warning, the alarm condition will cause the red LED on the face of the EGCP-2 to flash continuously until the alarm condition is acknowledged. No control actions occur as a result of a warning condition.

Visual Alarm

When an alarm set point is set for Visual Alarm, the alarm condition will cause the visual alarm output relay to energize, and the red LED on the face of the EGCP-2 to Flash. Both indicators will remain active until the alarm condition is acknowledged. No control actions occur as a result of a visual alarm condition.

Audible Alarm

When an alarm set point is set for Audible Alarm, the alarm condition will cause the audible and visual alarm output relays to energize and the red LED on the face of the EGCP-2 to flash. All alarm indicators will remain active until the alarm condition is acknowledged. No control actions occur as a result of an audible alarm condition.

Soft Shutdown

When an alarm set point is set for Soft Shutdown, the alarm condition will cause the generator to ramp off load, unless it is the only unit carrying the load in which case it will immediately open its gen breaker. If the unit has carried load above its cooldown limit, the unit will also cool down and then shut off. The audible, and visual alarm relays will energize at the time of the alarm condition, and the red LED on the face of the EGCP-2 will stay on continuously. Acknowledging the alarm condition will cause the alarms to reset, and make the unit operational once again.

Hard Shutdown

When an alarm set point is set for Hard Shutdown, the alarm condition will cause the generator to immediately open its breaker, and immediately shut off. The audible, and visual alarm relays will energize at the time of the alarm condition, and the red LED on the face of the EGCP-2 will stay on continuously. A unit, which has experienced a hard shutdown condition, will remove itself from any automatic sequencing displays. Acknowledging the alarm condition will cause the alarms to reset, and make the unit operational once again.

In addition to these standard shutdowns and alarms, there are five additional mains sensing parameters that can be programmed for Disabled, Warning, Loss of Mains, or Loss of Mains with Alarms. Disabled and Warning set points actions are identical to those described for other alarms.

Loss of Mains action will:

- Indicate a failed mains on the LCD Display (all modes)
- Issue a command to open the mains breaker or contactor (Auto mode only)
- Issue a command to start the engine(s) and put the generator(s) on load (Auto mode only)

Loss of Mains with Alarms action will do all of the actions assigned to the Loss of Mains condition, as well as activate the audible alarm function (audible and visual alarm outputs energize).

These 5 items, located in the Transfer Switch menu, can be configured for a Loss of Mains condition:

Load Surge

Senses a step kW load change (% of Rated Load Set Point per Second) on generator. LOM indication is immediate (no delay) for this condition.

Mains Frequency Low

Detects Mains Under-frequency condition for at least as long as the LOM Action Delay set point (seconds).

Mains Frequency High

Detects Mains Over-frequency condition for at least as long as the LOM Action Delay set point (seconds).

Mains Voltage Low

Detects under-voltage on the mains for at least as long as the LOM Action Delay set point (seconds).

Mains Voltage High

Detects over-voltage on the mains for at least as long as the LOM Action Delay set point (seconds).

Chapter 4. Software Overview

Introduction

The Software Overview explains what information the EGCP-2 will display, and describes the configuration items in each menu. Application Manual 26175 shows the different combinations of discrete inputs and configuration settings for the various operating modes.

The software used in the EGCP-2 uses state machine logic to operate all modes. State machine logic relies on discrete inputs and specific operating conditions to trigger a sequence of operations.

Status Screens

There are nine status menus in the EGCP-2. Use the status keys on the face of the EGCP-2 to access these status menus. The information in the status menus is dynamic and updates about every 200 milliseconds.

When the EGCP-2 is initially powered up, it will default to the System Status Screen. Below is an example of what the Screen may look like. The System Status Screen can be accessed while in any other status screen by pressing the SYSTEM key.

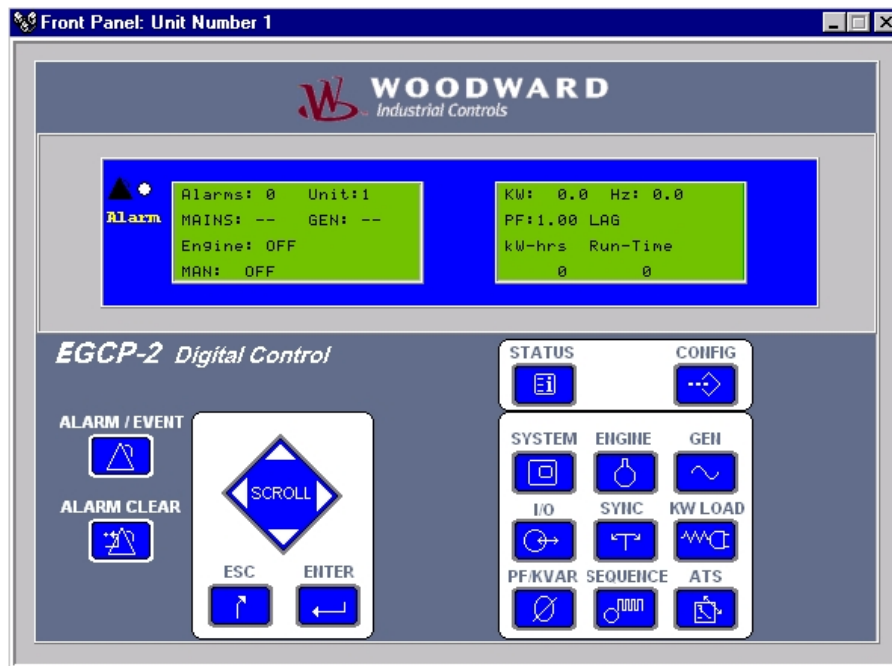

Figure 4-1. System Overview Engine Off Line

The screen displays the following information:

Alarms: Number of active alarms on the unit.

Unit #: The network address of the unit.

Mains: A graphic display of the mains condition. Two minus symbols (--) indicate the mains are out of spec, one plus symbol indicates the mains are in spec, but not declared stable (+-), two plus symbols (++) indicate the mains are in spec and stable.

Gen: A graphic display of the status of the generator. Two minus symbols (--) indicate the generator is out of spec, one plus symbol indicates the gen is in spec, but not declared stable (+-) two plus symbols (++) indicate the generator is in spec and stable.

Engine: The operating state of the engine.

Engine Control States:

- OFF
- PREGLOW
- CRANK
- RUN
- COOLDOWN
- SPINDOWN
- RETRY

Operating State: Shows if the EGCP-2 is in AUTO or MAN (manual) mode.

Load Control State: Shows the state of the load control logic of the EGCP-2.

The load control states are:

Load Control States:

- OFF
- DROOP
- ISOCHRONOUS
- BASELOAD
- PROCESS

KW: The total kW load on the generator.

Hz: The frequency, in Hertz, of the generator set.

PF: The average three phase power factor of the generator set.

KW-Hrs: The total accumulated kW hours produced by the generator set. This display automatically switches to MW-Hrs when the kW-Hour value exceeds 10 000. Display is updated every 0.1 MW-Hrs.

Run-Time: The total accumulated run time of the generator set. Display is updated every run hour.

All the display information will update automatically as operating modes and conditions to the EGCP-2 change.

This is what the System Status screen would look like with the mains out of spec, the engine running, carrying 100 kW load isochronously, and the generator voltage and frequency is within specified limits. This would be a typical screen if the unit was set for loss of mains detection, and the mains had failed.

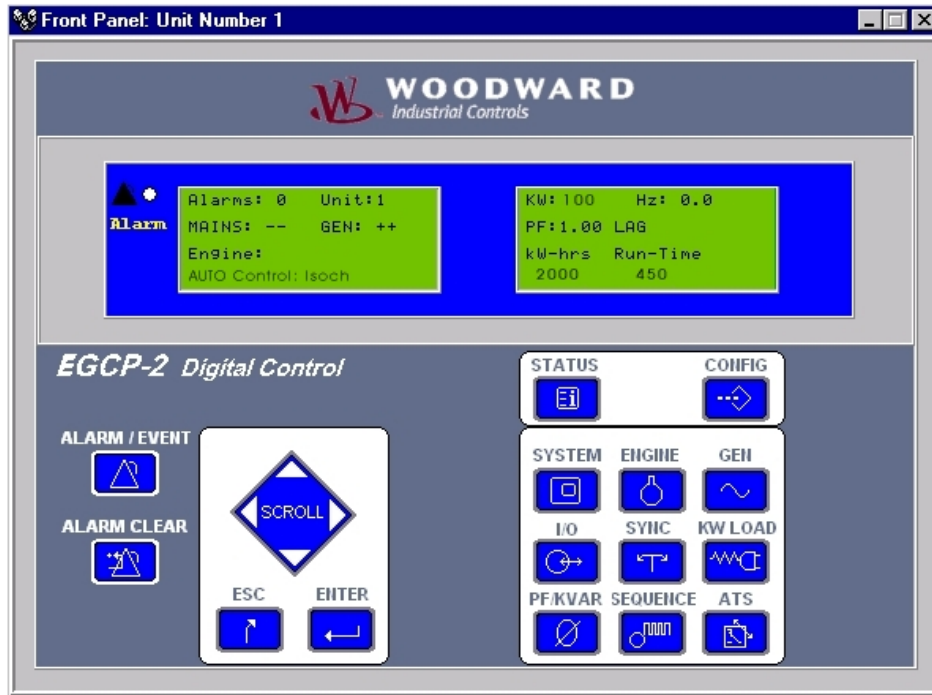

Figure 4-2. System Status Screen—Isochronous

This is what the System status screen looks like for a generator set that is base loaded to the mains at 500 kW, 0.80 lagging PF, with one unacknowledged alarm.

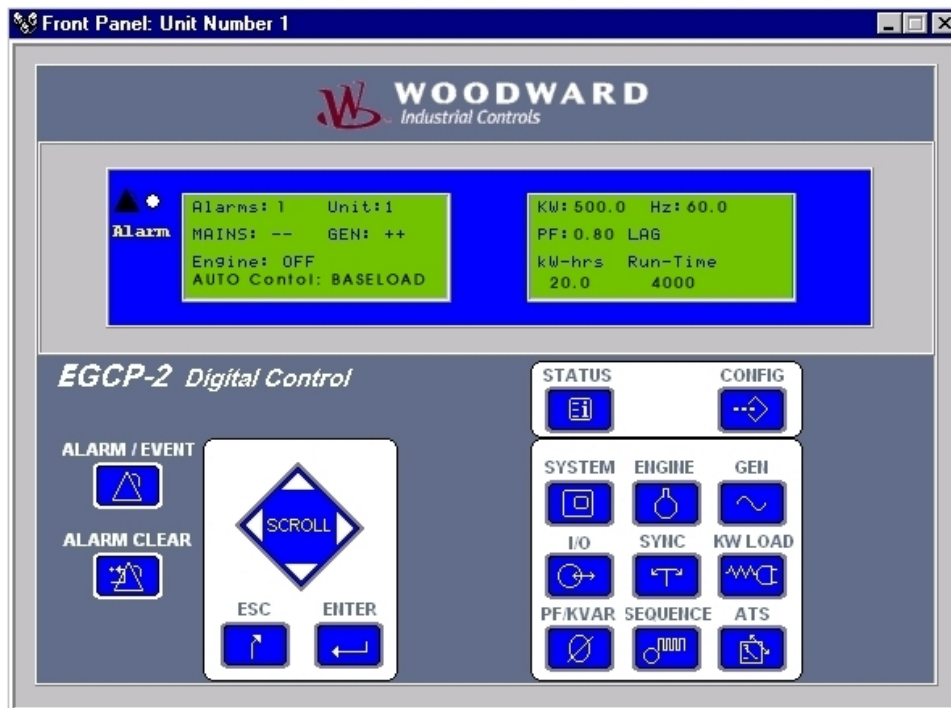

Figure 4-3. System Status Screen—Baseload

The following is an overview of each of the status menu screens, starting with Engine status:

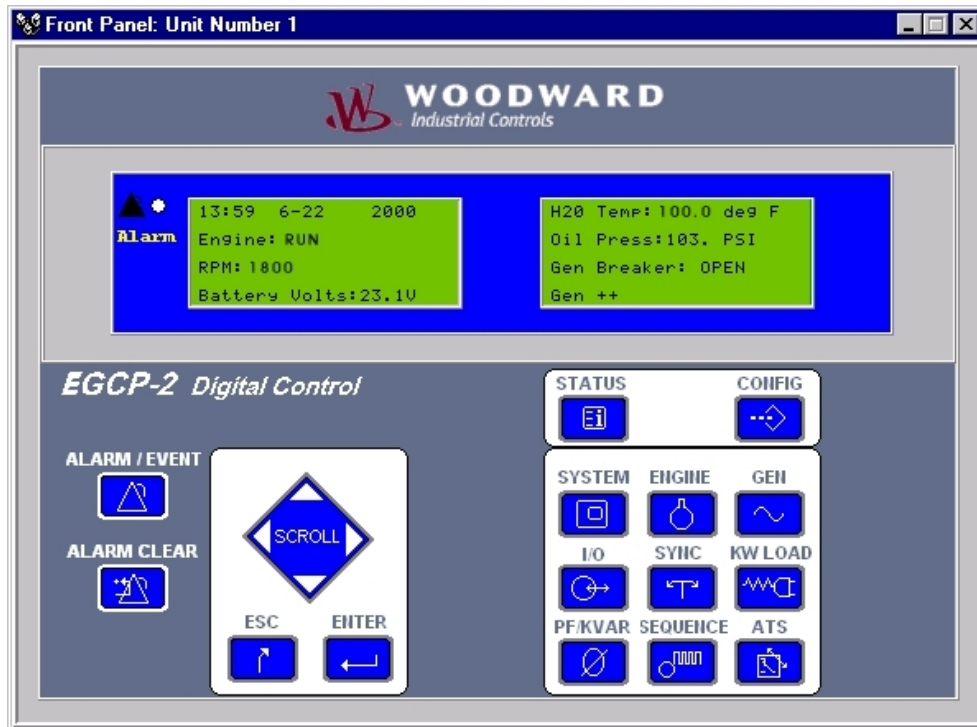

Figure 4-4. Engine Status

HH:MM: 24 hour clock readout.

MM-DD: Date (MM-DD).

Engine: The state of the engine control function.

RPM: Engine rpm.

Battery Volts: Battery Voltage in Vdc.

H2O Temp: Water Temperature in degrees C or F, depending upon the Configuration menu, Display Units setting.

Oil Press: Oil Pressure in Bar or psi, depending upon the Configuration menu, Display Units setting.

Gen Breaker: The Status of the generator breaker as provided by the gen CB aux discrete input.

Gen: The status of the generator. Two minus symbols (--) indicates the generator is out of spec, one plus symbol indicates the gen is in spec, but not declared stable (+-) two plus symbols (++) indicate the generator is in spec and stable.

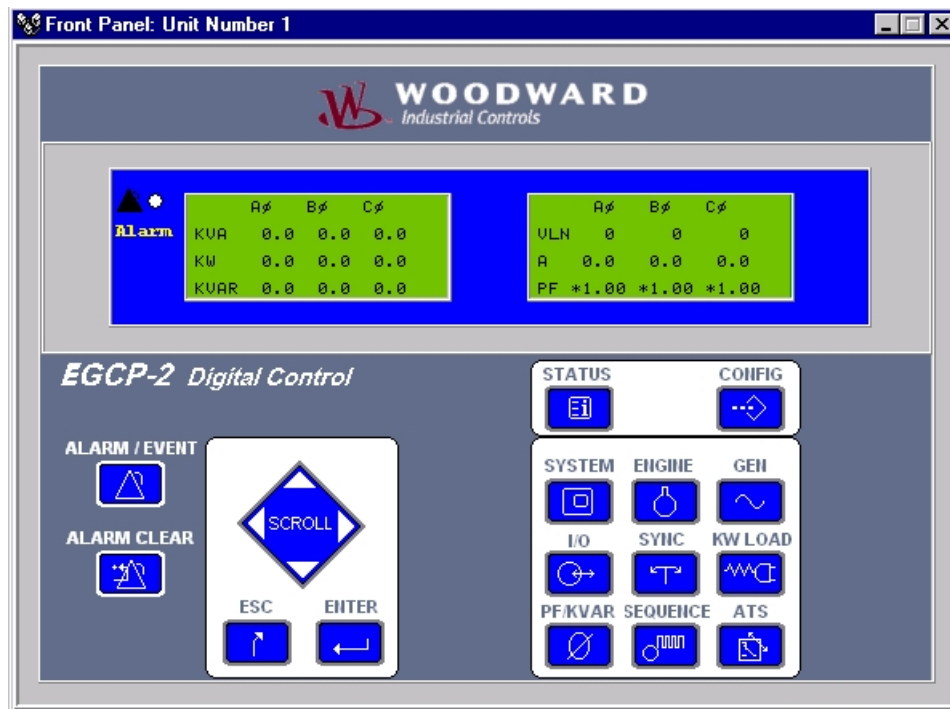

Figure 4-5. Generator Status (Voltage Line to Neutral)

A B C: Three phase readings for the generator.

KVA: Three phase kVA readings.

KW: Three phase kW readings.

KVR: Three phase kVAR readings.

V: Volts for each phase of the generator.

A: Amps per phase for the generator.

- Will not display negative amps.

PF: Power Factor for each generator phase.

IMPORTANT

Generator voltage label, VLL—Voltage Line-to-Line or VLN—Voltage Line-to-Neutral will be determined from the Voltage Input configuration setting.

Generator voltage readings and labels will automatically switch from “V” (volts) to “KV” (kilovolts), when the voltage exceeds 9999 V for that input.

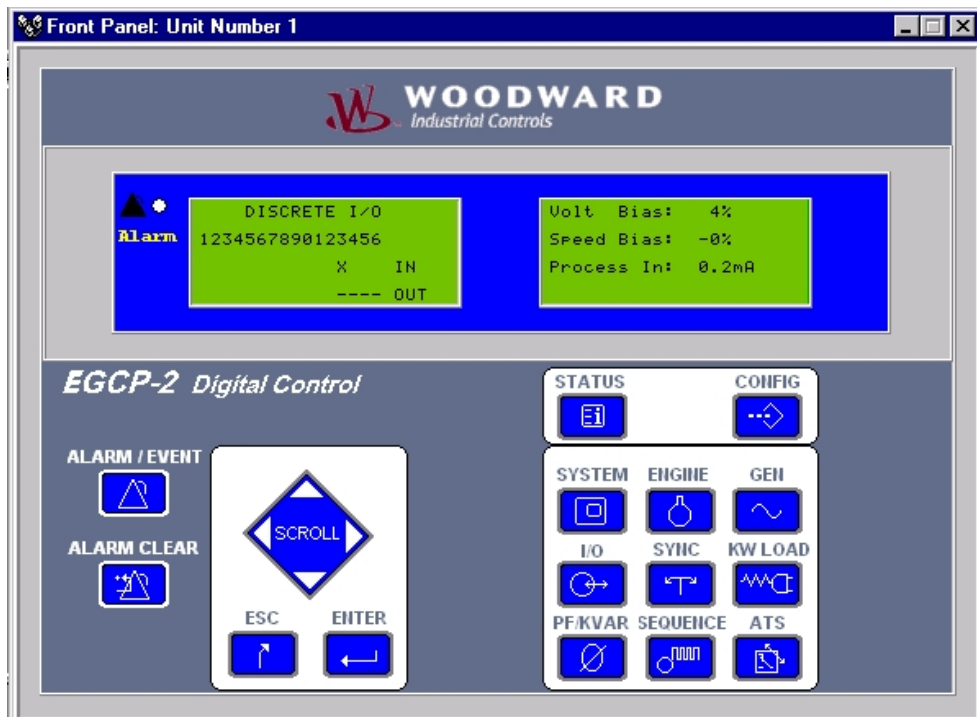

Figure 4-6. I/O Status

IN: Discrete Inputs 1 through 16.

OUT: Discrete Outputs 1 through 12.

Volt Bias: % voltage bias output ($\pm 100\%$ range).

Speed Bias: % speed bias output ($\pm 100\%$ range).

Process In: Process Input will be displayed in Engineering Units configured in the Process menu. Shown in Milliamps.

Discrete Inputs

1. Automatic Switch
2. Test Switch
3. Run with Load Switch
4. Volts Raise
5. Volts Lower
6. Speed Raise
7. Speed Lower
8. Gen Circuit Breaker Aux Contact
9. Mains Circuit Breaker Aux Contact
10. Process Switch
- 11–16. Remote Alarm/Shutdown Inputs

Discrete Outputs

1. Mains Breaker Close/Contactor Close
2. Gen Breaker/Contactor Close
3. Engine Preglow
4. Fuel Solenoid
5. Engine Crank
6. Visual Alarm Relay
7. Local Bus PT Connect
8. Mains PT Disconnect
9. Mains Breaker Trip
10. Gen Breaker Trip
11. Audible Alarm
12. kVA load switch, or Idle/Rated Switch, depending on configuration

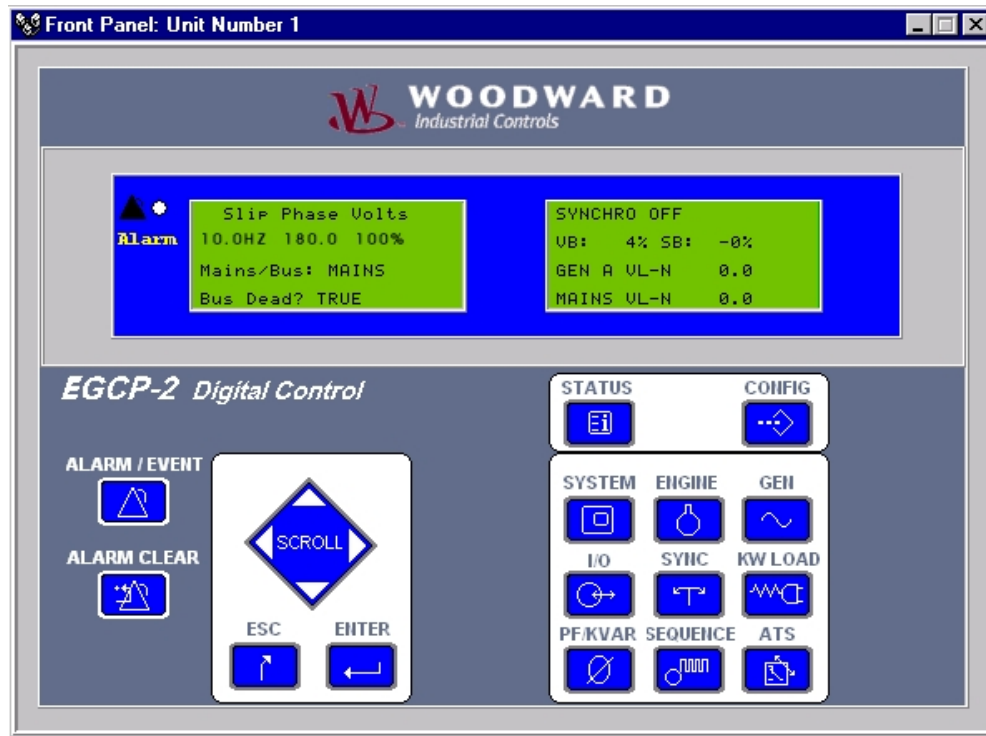

Figure 4-7. Synchronizer Status

Slip: The slip frequency in Hz. of the generator in relation to the bus or mains it is paralleling to.

Phase: The phase angle difference in degrees between the generator and the bus or mains it is paralleling to.

Volts: The voltage differential in percent between the generator and the bus or mains it is paralleling to.

Mains/Bus: The active PT input being monitored by the EGCP-2.

Dead Bus: Indicates if the PT input (mains or bus) being measured is dead.

Synchronizer Status: Displays the state of the synchronizer. These states are:

| | |
|--------------------|-------------|
| CLOSE GEN BREAKER | SYNC TIMER |
| OPEN GEN BREAKER | IN SYNC |
| CLOSE MAIN BREAKER | SYNCHRO OFF |
| OPEN MAIN BREAKER | |

VB: Voltage Bias Output (%)

SB: Speed Bias Output (%)

GEN A: Voltage of the generator.

MAINS: Voltage of the active PT input being sensed by the synchronizer.

IMPORTANT

Generator and Mains voltage label, VLL—Voltage Line-to-Line or VLN—Voltage Line-to-Neutral will be determined from the Voltage Input configuration setting.

Generator and Mains voltage readings and labels will automatically switch from “V” (volts) to “KV” (kilovolts), when the voltage exceeds 9999V for that input.

The synchronizer displays **** in the place of Slip, Phase, and Volts when the synchronizer is inactive, or off.

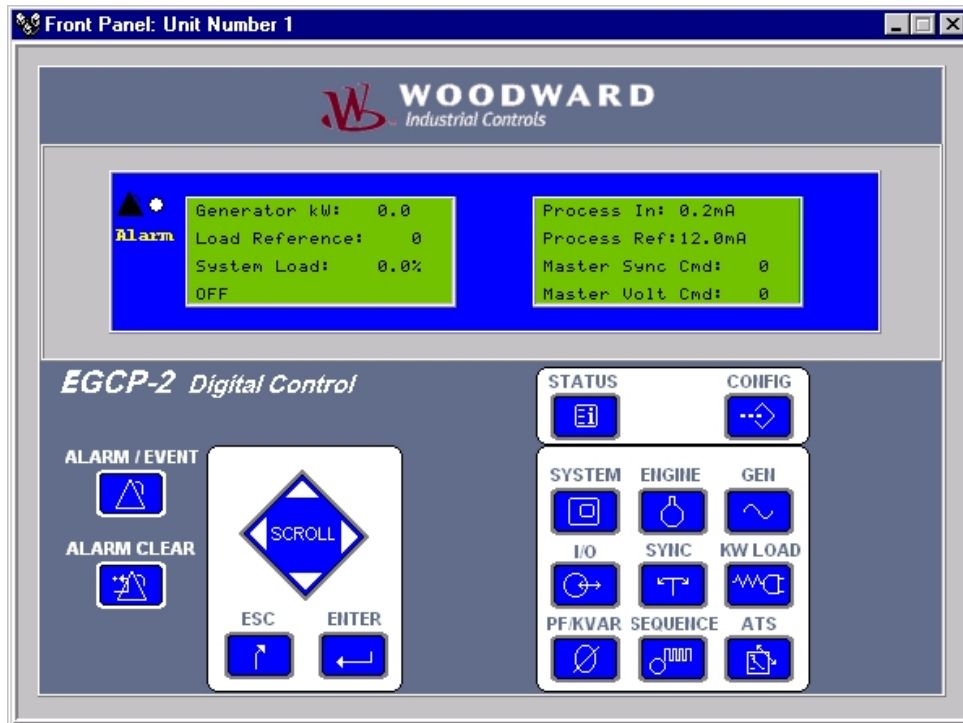

Figure 4-8. kW Load Status

Generator KW: The total, three phase kW the generator is producing.

Load Reference: The load reference, in kW for the generator.

System Load: The calculated system load for all units operating in isochronous load sharing mode. This reading is NOT active in the Baseload mode.

Control: The current load control state in operation. These states are:

OFF
DROOP
ISOCHRONOUS
BASELOAD
PROCESS

Process In: The sensed value of the 4–20 mA or 1–5 Vdc process input. This value will be displayed in an Engineering Unit that is configured in the Process menu under Process Units.

Process Ref: The process reference for the process control.

Master Sync Cmd: The master synchronizing and load control bias command (%).

Master Volt Cmd: The master voltage bias command (%).

IMPORTANT

The master sync and master volt commands are only active in Slave units that are in AUTO.

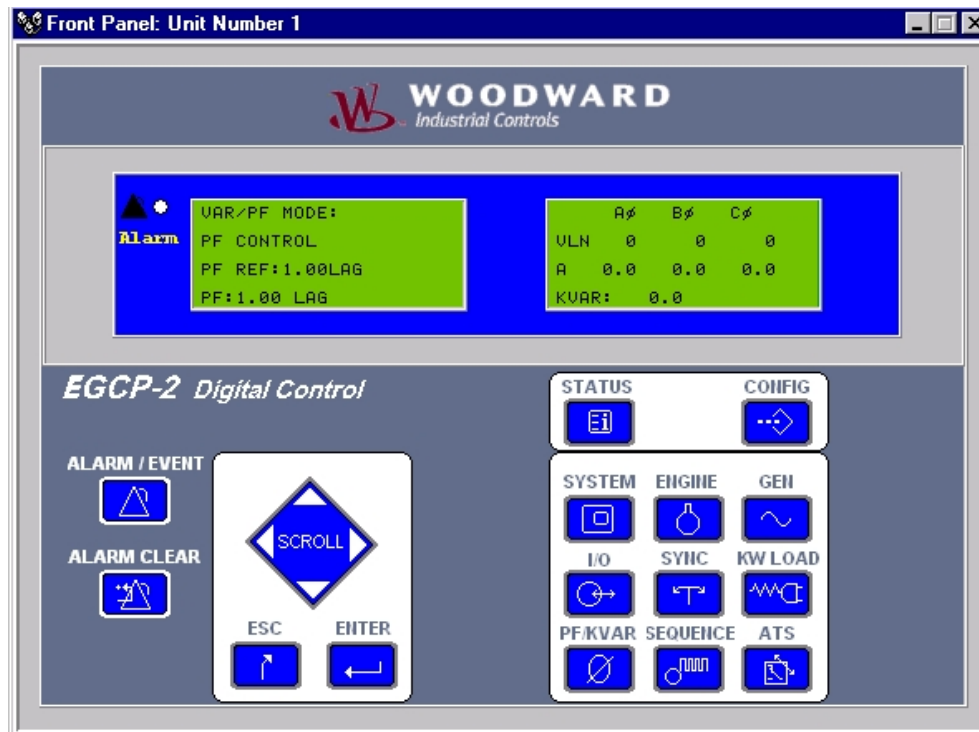

Figure 4-9. PF /kVAR Status

VAR/PF MODE: The configured VAR/PF control mode.

PF REFERENCE: The PF control reference value for the control.

IMPORTANT

Power Factor (PF) reference changes to kVAR REF when in VAR control.

- PF:** The average three phase PF of the generator.
- A B C:** A, B, C phase generator reading indication.
- V:** Three phase voltage readings for the generator.
- A:** Three phase current readings for the generator.
- KVAR:** Total kVAR reading for the generator.

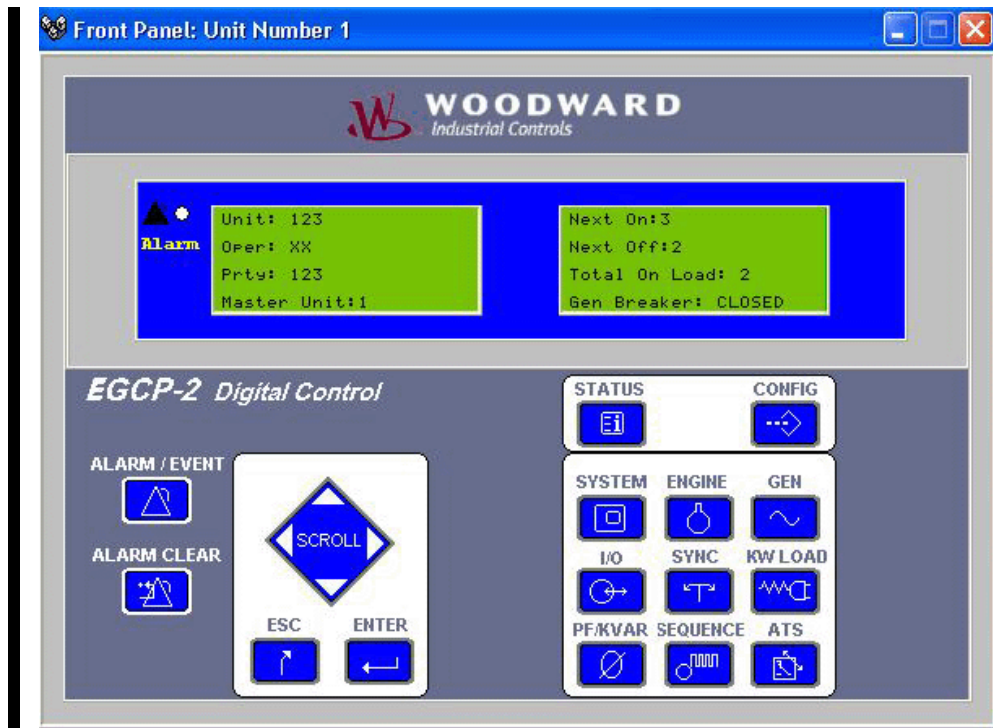

Figure 4-10. Sequencing Menu

Unit: Network Address of all units in Auto on the network.

Oper: Units in auto, and on the network with their breakers closed will have an X under their Address.

Prty: Network Priorities of all units in auto on the network.

Master Unit: The unit with the highest priority (lowest priority number) that is on the network and in auto.

Next On: Network address of next unit to be sequenced onto the network.

Next Off: Network address of next unit to be sequenced off the network.

Total On Load: Total number of load sharing units operating in isochronous load sharing.

Gen Breaker: The status of the generator breaker as determined by the gen CB aux discrete input.

The example below is a typical sequencing screen for a 5-unit system.



Figure 4-11. Sequencing Menu (Multi-Unit)

As displayed on the sequencing screen:

Units 1, 3, and 5 are on load with their generator breakers closed.

Next On is unit number 2, which has a network priority of 4.

Next Off is unit number 5, which has a network priority of 3.

Master Unit in this system is the unit with the lowest priority, which is unit number one.

IMPORTANT

Units that have active shutdowns will remove themselves from the sequencing menu until the shutdown condition(s) are cleared.

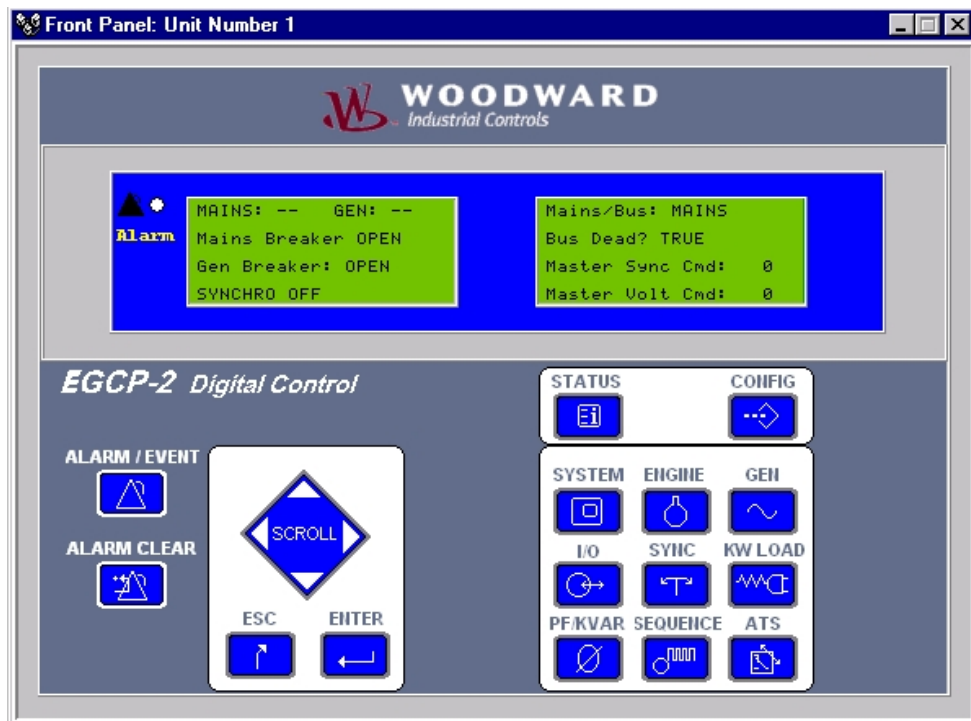

Figure 4-12. ATS (Automatic Transfer Switch) Status.

Mains: A graphic display of the mains condition. Two minus symbols (--) indicates the mains are out of spec, one plus symbol indicates the mains are in spec, but not declared stable (+-) two plus symbols (++) indicate mains are in spec and stable.

Gen: A graphic display of the gen condition. Two minus symbols (--) indicates the generator is out of spec, one plus symbol indicates the generator is in spec, but not declared stable (+-) two plus symbols (++) indicate generator is in spec and stable.

Mains Breaker: The state of the mains breaker as determined by the mains CB aux discrete input.

Gen Breaker: The state of the generator breaker as determined by the gen CB aux discrete input.

Synch: The synchronizer control state.

Mains/Bus: The PT input being sensed by the mains/bus PT input through the mains disconnect, bus connect discrete output logic.

Bus Dead: An indication of a live or dead local bus as determined by the voltage on the bus, and state of the generator and mains breaker inputs.

Master Sync Cmd: The master synchronizing and load control bias command (%).

Master Volt Cmd: The master voltage bias command (%).

IMPORTANT

The master sync and master volt commands are only active in Slave units that are in AUTO.

Security Access

Security Code Required For Access

The EGCP-2 has built-in security to protect against configuration changes and alarm purges by unauthorized personnel. There are five levels of access to the configuration menus. They are listed below. Each successive level has access to all of the levels above. A four-digit security code is required for access to the configuration menus. If an incorrect code is entered, or a proper code is not entered within 300 seconds, the displays will default to the last Status screen selected.

Levels Of Access

Monitor (no security code)

Access to all Status Screens, view Alarm / Event Log Display, and ability to commit (clear) an Audible Alarm.

Operator

Access to view and clear Alarm / Event Log and change the Network Priority.

Supervisor

Allows access to change the Network Address and Time Setting (Clock).

Technician

Allows access to all set points except Engine Run Time and the Calibration menu.

Factory

Full access, includes the Engine Run Time and the Calibration menu.

When the Config key on the EGCP-2 keypad is pressed, the right LCD screen will switch to the configuration menus. A Security Code prompt will be provided prior to access into the Configuration Menus. The Security Code value determines which configuration menus are accessible and if the Alarm / Event log can be cleared.

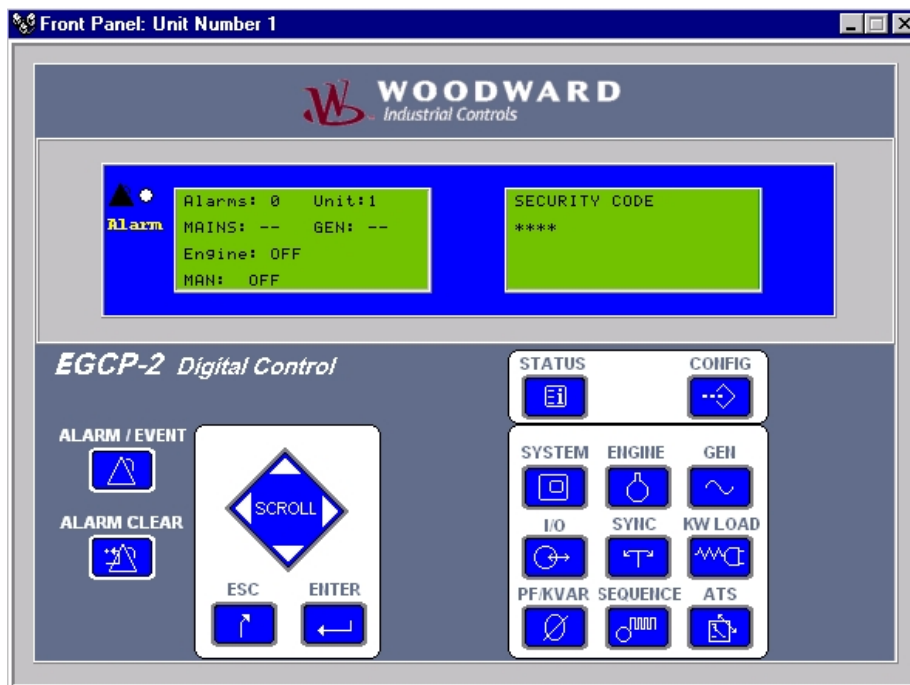

Figure 4-13. Security Code Display

IMPORTANT

See manual 26108 (shipped with each control) for security code and access level information.

Once a Security Code is entered, it will stay active until:

1. The DC power is cycled, causing the EGCP-2 to re-boot.
2. When in any of the Configuration Menus, press the “ESC” key twice. This will return you to the Security Code screen.

If neither of these steps are done, the Configuration Menus and Alarm / Event menu will be available at the level of the last Security Code entered.

Alarm / Event Log

The Alarm / Event button provides access to the EGCP-2’s Alarm and Event Log. This log contains up to sixteen individual warning, alarm, or shutdown items. When the Alarm / Event button is pressed on the EGCP-2 keypad, the right hand LCD screen will switch to the Alarm/Event log. This log displays the following information. For navigation within the Alarm / Event log see the menu navigation section of this manual.

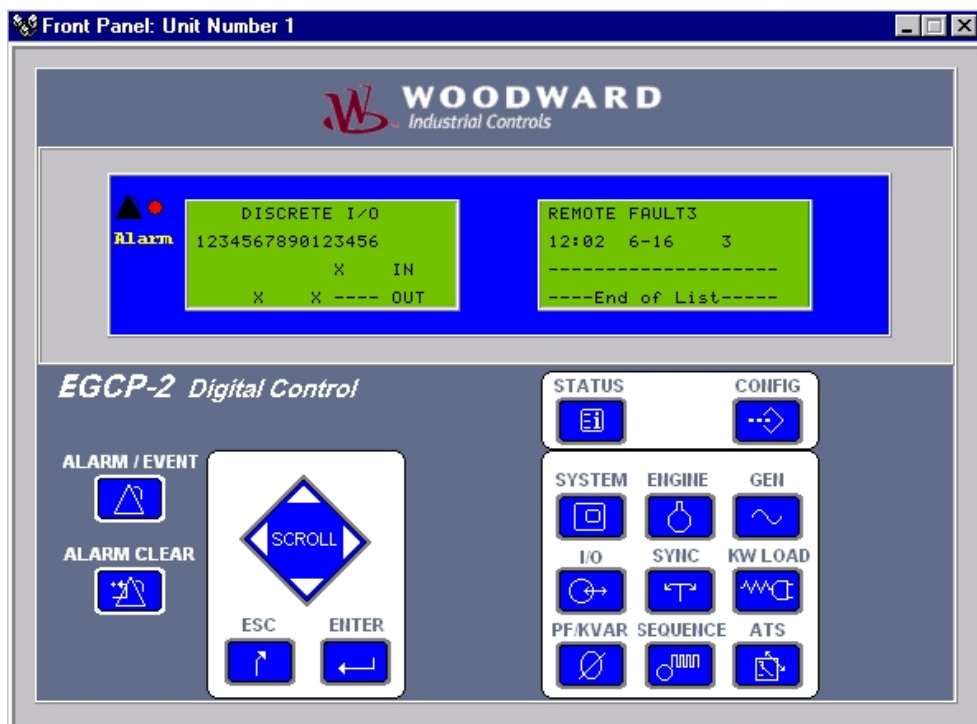

Figure 4-14. Alarm / Event Screen

ALARM NAME: The name, as defined by the particular warning, alarm, or shutdown event.

HH:MM: The hour and minute of the alarm occurrence.

MM-DD: The Month and Day of the alarm occurrence.

####: The value of the input at the time of the alarm. This value is visible with a supervisor level, or higher, security code.

In the event that the Alarm /Event Log key is pressed, and there are no active or logged alarms, the display will look like this:

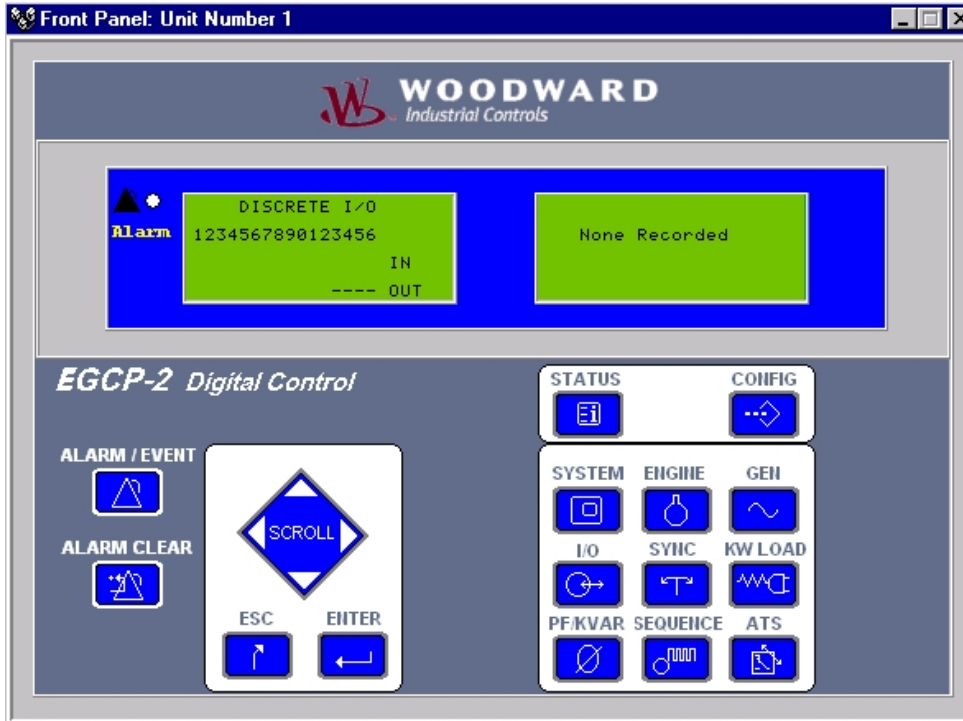

Figure 4-15. Empty Event Log

The alarms displayed in the alarm / event log are arranged in a first in, last out (FILO) order. The most recent alarms will appear at the top of the list, followed by older alarms. In the event that the total number of logged and unacknowledged alarms exceeds sixteen, the oldest alarms will be dropped off the list to make room for the newer alarm events. If power is cycled to the control, the Event log will be cleared.

Configuration Menus

When a valid security code is entered, the configuration menu list will be displayed. The configuration list allows the user to configure, calibrate, and adjust all relative items to the EGCP-2 operation.

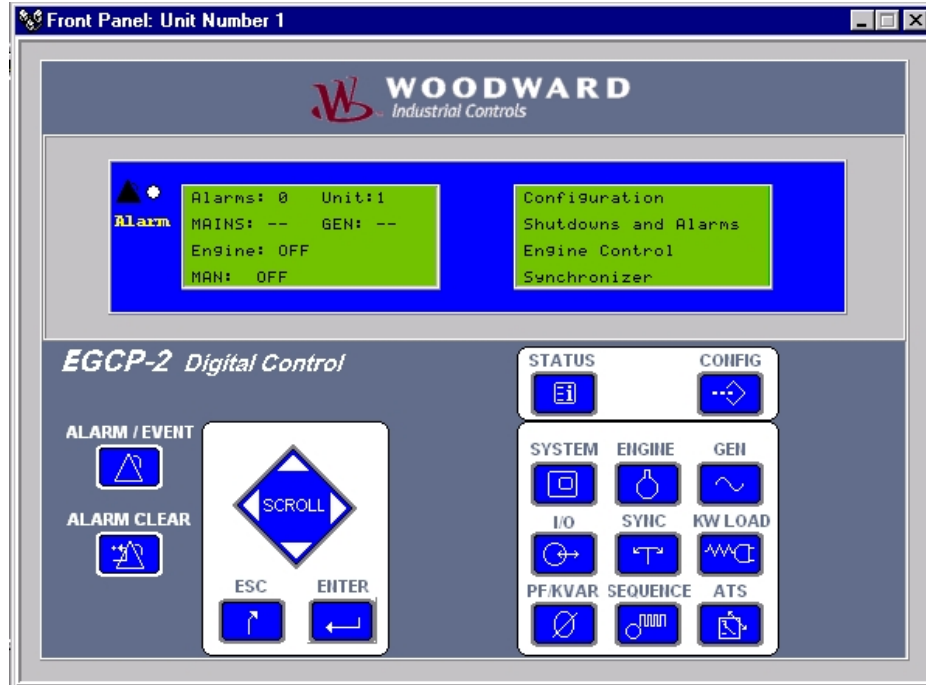

Figure 4-16a. Configuration Menu List (Screen 1)

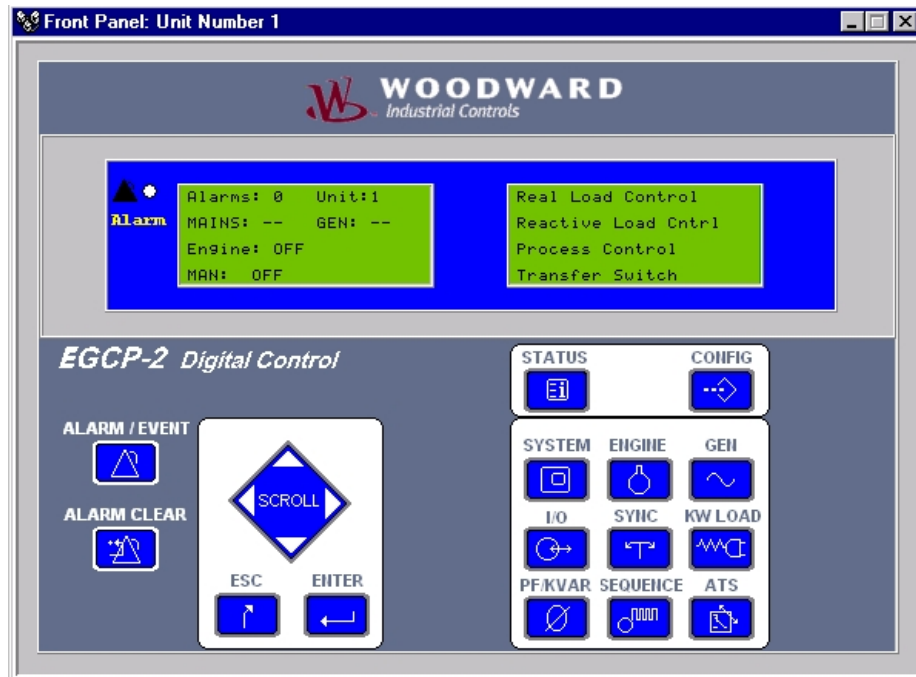

Figure 4-16b. Configuration Menu List (Screen 2)

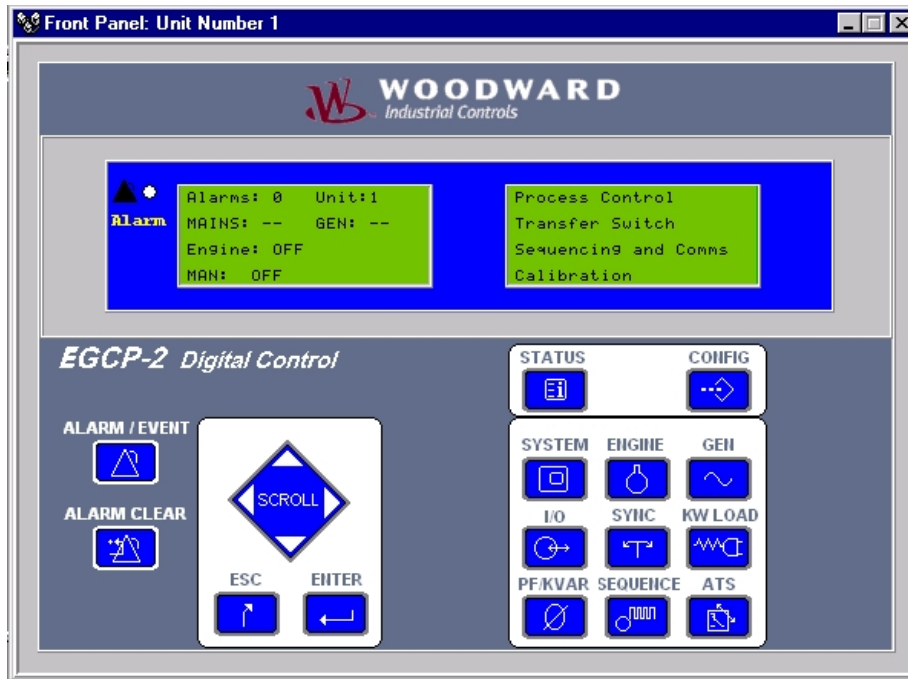

Figure 4-16c. Configuration Menu List (Screen 3)

IMPORTANT

See Manual 26108 (shipped with each control) for security code and access level information.

Various Security codes access different portions of the configuration screens, depending on the level of security code used. The up and down keys are used to move the blinking cursor to the tuning menu that the user wants to enter. Pressing the enter key will access that configuration menu. See the Navigation Procedure in Chapter 2 of this manual for information on navigating through the configuration menus.

Sanity Checks

In order to prevent improper configuration that may damage the generator set when started, the EGCP-2 runs through a series of “sanity checks”. The items involved, all in the Configuration menu, for these “sanity checks” are:

1. Numbers of Poles
2. Number of Teeth
3. System Frequency
4. Rated Speed
5. Rated kW
6. Rated kVA
7. CT Ratio
8. PT Ratio
9. Voltage Input
10. Voltage Ref

The “sanity checks” are performed when:

1. Power is cycled
2. Access any Configuration menu by pressing the ENTER key. Pressing the ENTER key a second time will initiate a sanity check.

If a “sanity check” is present the red Alarm LED will blink on the face of the control. Access the Alarm/ Event menu and it will say: Program Config Error

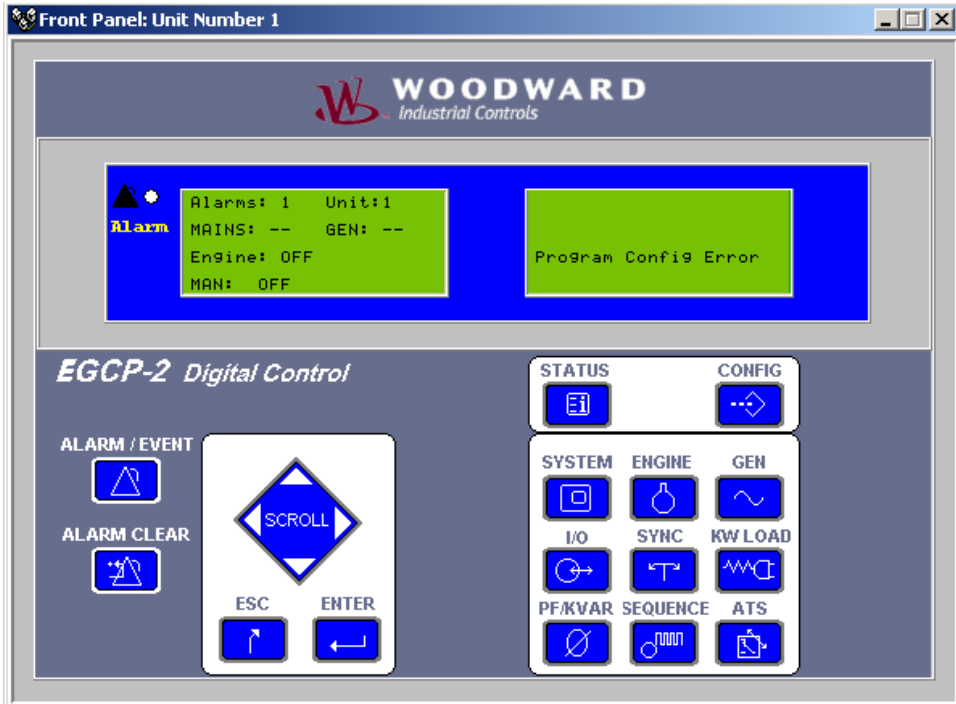

Figure 4-17. Program Configuration Error

- Items in the Configuration menu that fail the “sanity checks” will be indicated by a pound sign (#). This pound sign will appear on the far right side of the items value on the display screen. If any items have a pound sign, the engine will not be allowed to start and all Alarm and Shutdown conditions are ignored. At least one of these items must be changed to be within calculated values (sanity checks) to allow engine, alarm, and shutdown operations.
- The sanity checks are divided into two groups:
 - o Speed Calculations, pound signs (#) will appear on all items if any test fails
 - Number of Poles, Number of Teeth, System Frequency, and Rated Speed
 - o Power Calculations, pound signs (#) will appear on all items if any test fails
 - Rated kW, Rated kVA, CT Ratio, PT Ratio, Voltage Input, and Voltage Reference
- All items in the Configuration menu must be Committed before engine operation will be allowed. Uncommitted items will have an asterisk (*) next to the item’s value on the display screen. Asterisks will appear whenever a Set Point file is downloaded to an EGCP-2. To commit an item you must press the ENTER key. Open the Configuration menu and open each item, then ENTER that item. The asterisk will be gone.

The “sanity checks” are:

1. **Calculate MPU frequency** = Rated Speed * Number of Teeth / System Frequency
 - Answer: $500 \leq \text{calculated MPU frequency} \leq 8000$ = Unit OK
2. **Calculate System Frequency** = Rated Speed * Number of Poles / 120
 - Answer: should equal System Frequency’s configured value, 50 or 60 Hertz
3. **Calculate Power Factor** = Rated kW / Rated kVA
 - Answer: $0.7 \leq \text{Calculated Power Factor} \leq 1$ = Unit OK
4. **Calculate CT Ratio, Voltage Input is DELTA, =**
kVA * 1000 / Voltage Ref * 1.73
 - Answer: If value is \leq CT Ratio = Unit OK
5. **Calculate CT Ratio, Voltage Input is WYE, =**
kVA * 1000 / Voltage Ref * 3
 - Answer: If value is \leq CT Ratio = Unit OK
6. **Calculate Voltage** = Voltage Ref / PT Ratio
 - Answer: If Calculated Voltage ≤ 500 = Unit OK
7. **Calculate Rated kVA, Voltage Input is DELTA,**
 - Answer: Calculated kVA $\leq (\text{Voltage Ref} * 1.73) * \text{CT Ratio}$ = Unit OK
8. **Calculated Rated kVA, Voltage Input is WYE,**
 - Answer: Calculated kVA $\leq (\text{Voltage Ref} * 3) * \text{CT Ratio}$ = Unit OK
9. **Rated kW \leq Rated kVA = Unit OK**

If the EGCP-2 is not providing an engine start signal:

- Check for pound signs (#) signs and/or asterisks (*).
- If any item is open in the Configuration menu (does not pertain to any of the other menu) no start operation will be performed until this item is closed by pressing the ENTER or ESC key.

Example—If viewing “Rated KW” in the Configuration menu, no start signal will be provided.

Network Address

- Range: 1 to 8
- Unique Address for Each Unit in the System.
- Maximum of 8 units on network.

Network Priority

- Range: 1 to 8
- Unique Priority for Each Unit in the System.
- **Lowest Active Priority** is considered Master.
- Maximum of 8 units on network.
- Sequencing effective from lowest to highest priority.
- When priority is reduced below 1, the value will change to “Set All”. If the Enter key is pressed when this value is on the display, the display will change to represent all units in auto on the network, and their priorities. Using the left/right and up/down keys on the control, one can change the network priority of any unit. Once changes are made, the changes are committed by pressing the Enter key twice. Pressing the Escape key from within the Set All parameter will restore the previous priorities.

Number of Poles

- Range: 2—18
- Determines Speed/Frequency Relationship.
- Number of Poles = $120 * \text{Hertz} / \text{rpm}$

| Number of Poles | 60 Hertz Generator | 50 Hertz Generator |
|-----------------|--------------------|--------------------|
| 2 | 3600 rpm | 3000 rpm |
| 4 | 1800 rpm | 1500 rpm |
| 6 | 1200 rpm | 1000 rpm |
| 8 | 900 rpm | 750 rpm |
| 10 | 720 rpm | 600 rpm |
| 12 | 600 rpm | 500 rpm |
| 14 | 514 rpm | 428 rpm |
| 16 | 450 rpm | 375 rpm |
| 18 | 400 rpm | 333 rpm |

Number of Teeth

- Range: 16—500
- Determines rpm Scaling.
- Engine Speed Readouts/Alarms.

System Frequency

- Range: 50 or 60 Hz
- Used as a basis for generator waveform analysis.
- Defines typical operating frequency of generator.

Rated Speed

- Synchronous Speed Of Generator Set.
- Used in Speed Calculation to determine “sample” period for MPU input.

Rated KW

- Range: 1—30000
- Rated kW of Generator
- Typically 0.8 x rated kVA

Rated KVA

- Range: 1—30000
- Rated kVA of Generator

Rated KVAR

- Range: 1—30000
- Rated kVAR of Unit.
- Typically 0.6 x Rated kVA.

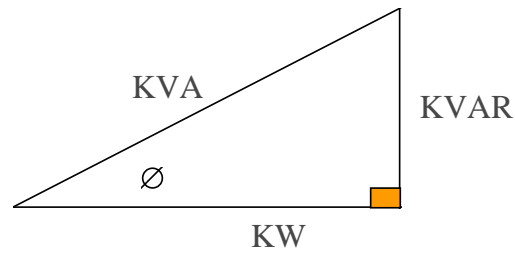

$$KW/KVA=PF$$

$$\text{COS } \emptyset =KW/KVA$$

$$KVA^2=KW^2+KVAR^2$$

$$KVA= \sqrt{(KW^2 + KVAR^2)}$$

Figure 4-18. AC Power Triangle

CT Ratio

- Range: 5—30000 :5
- Scales sensed CT input for Amperage as seen at generator.
- Used for Load Sensing Algorithm.
- (kVA, kW, kVAR, PF)
- Used for Alarms/Shutdowns.
- Overcurrent, kW Limits, Reverse Current, etc.

PT Ratio

- Range: 1—1000 : 1
- Scales sensed PT input to Voltage Levels as measured at the Generator.
- Used in Load Sensing Algorithm.
- (kVA, kW, kVAR, PF)
- Used for Voltage Matching.
- Used for Generator Frequency Detection.
- Used for Alarm/Shutdown sensing.
- Over/Under Voltage
- kW Limits, etc.

Voltage Input

- Range: Wye L-N or Delta L-L
- Set for sensing/transformer used between generator and EGCP-2.
- Defines which calculations will be used for kW, kVA, kVAR, etc.
- Defines the expected input type for voltage levels in the set point menus.
- Sets the label used for all generator and mains voltage Status readings.
- Wye (Star) Generator or Transformer Connection
4 Wire
Volts Line to Neutral expected for all set point menu items requiring voltage settings.
- Delta Generator or Transformer Connection
3 Wire
Volts Line to Line expected for all set point menu items requiring voltage settings.

Voltage Reference

- Range: 1—30000
- Operating Voltage of Generator per Generator Nameplate.
Used for VAR/PF Sharing as the Reference that multiple generators share reactive load to. This maintains the voltage reference while in Power Factor Sharing or kVAR Control mode on an isolated bus.

Display Units

- Range: American or Metric
- **Metric**
Sets temperature readings to degrees Celsius (C), and pressure to bar (BAR).
- **American**
Sets temperature readings to degrees Fahrenheit (F), and pressure to Pounds per Square Inch (psi).

Set Date

- MM-DD-YY
- Sets the date used by the control for Alarm / Event time stamps, and displays.

Set Time

- HH:MM
- Sets the time used by the control for Alarm / Event time stamps, and displays.

Start Sequencing

- Range: Enabled or Disabled
- **Enabled**
Uses Preglow time and Engine Crank.
Must have MPU to function.
- **Disabled**
No Preglow Time or Engine Crank
Will operate without an MPU

Relay #12 Function

- Range: kVA Load or Idle/ Rated Switch
- **kVA Load Switch**
Defines Discrete Output #12 as a kVA load switch.
Uses kVA High and kVA Low value items in the Load Control Configuration Menu.
- **Idle / Rated Switch**
Defines Discrete Output #12 as an Idle / Rated speed switch. This output is typically used to automatically send the engine speed control an idle/rated command upon start up.
Uses the Idle Speed and Idle Time items in the Engine Control Configuration Menu.

Speed Bias Type

- Range: ± 3 Vdc, 0.5–4.5 Vdc, or 500 Hz PWM
- **± 3 Vdc (WGC)**
Sets the speed bias output to ± 3 Vdc range. 0 Vdc is zero output, -3 Vdc is -100% speed bias output, $+3$ Vdc is $+100\%$ speed bias output.
- **0.5 to 4.5 Vdc (DDEC)**
Sets the speed bias output to 0.5 to 4.5 Vdc range. 2.5 Vdc is zero, 0.5 Vdc is -100% speed bias output, 4.5 Vdc is $+80\%$ speed bias output.
- **500 Hz PWM (ADEM)**
Sets the speed bias output to 500 Hz Pulse Width Modulated (PWM) range. 50% duty cycle = 0% speed bias output, 0% duty cycle = -100% speed bias output, 100% duty cycle = $+100\%$ speed bias output.

Voltage Bias Type

- Range: ± 1 , 3, or 9 Vdc
- **± 9 Vdc Bias**
0 Vdc = 0% voltage bias
 -9 Vdc = -100% voltage bias
 $+9$ Vdc = $+100\%$ voltage bias
- **± 3 Vdc Bias**
0 Vdc = 0% voltage bias
 -3 Vdc = -100% voltage bias
 $+3$ Vdc = $+100\%$ voltage bias
- **± 1 Vdc Bias**
0 Vdc = 0% voltage bias
 -1 Vdc = -100% voltage bias
 $+1$ Vdc = $+100\%$ voltage bias

Circuit Breaker Control

- Range: Breaker or Contactor
- Defines action of Generator and Mains closure command.
- Breaker issues momentary breaker close signal, and a separate momentary breaker trip (open) signal. Get complete logic for Generator and Mains breaker commands in chapter 3 under “Relay Outputs”.
- Contactor issues continuous breaker close signal through the breaker close relay output, DO2 for Generator and DO1 for the Mains.

Operating Mode

- Range: Mains Parallel or No Parallel
- **Mains Parallel** will allow the unit to synchronize to the mains, and carry load while in parallel with the mains as well (closed transition).
- **No Parallel** will not allow the unit to operate with load until the mains breaker is sensed as being open (open transition).
- All units operating in a load sharing system must be set for the same parameter (that is, mains parallel, or no parallel).

Number of Units

- Range: Single or Multiple
- Defines whether unit is part of a multiple unit system or not.
- If **single unit**, there is no auto starting, auto sequencing, load or PF sharing with other units under any circumstances. Unit displays “single unit no sequencing” on sequencing screen. Network Priority and Network Address set points are removed from the configuration set point menu automatically.
- If **multiple unit**, auto starting, auto sequencing, load and VAR/PF sharing are available between all units in multiple. Unit displays system sequencing information on sequencing screen. Network Priority and Network Address set points are added to the configuration set point menu automatically. Unit must be in Auto mode to communicate over the inter-control network (RS-485).

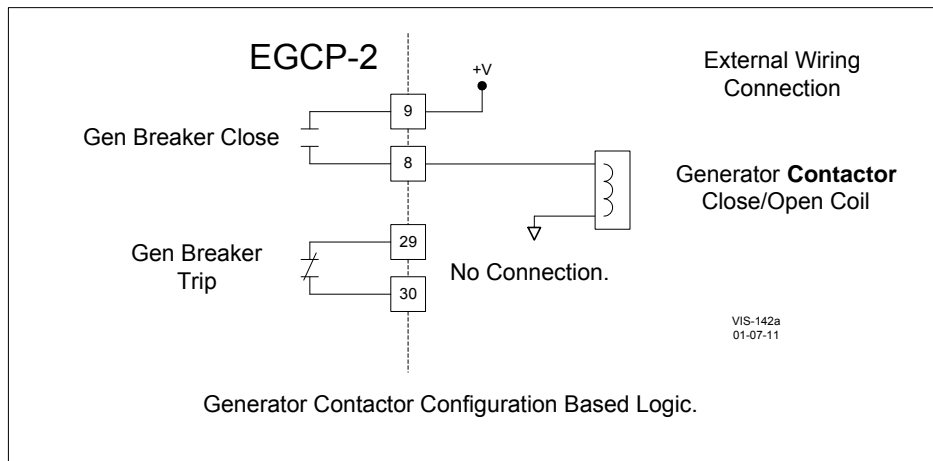
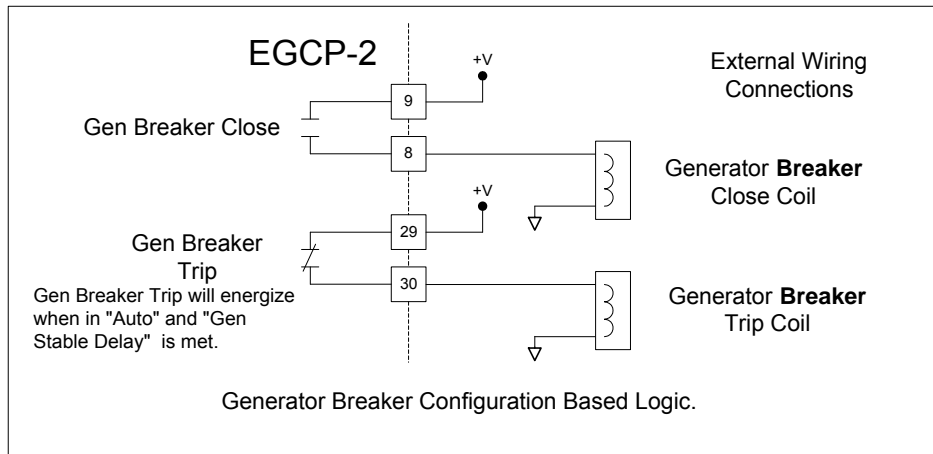

Figure 4-19. Breaker Logic and Contactor Logic

Shutdowns and Alarms

The Shutdowns and Alarms menu is used to configure the generator protection functions of the EGCP-2.

Each alarm set point can be set for:

- Disabled
- Warning—LED on control flashes.
- Visual Alarm—LED flashes, and Visual Alarm relay energizes.
- Audible Alarm—LED flashes, Visual and Audible Alarm relays energize.
- Soft Shutdown—LED turns on, Visual and Audible Alarm relays energize, unit soft unloads, Fuel Solenoid relay de-energizes and cycles through cool down timer when applicable. Unit removes itself from auto sequencing order.
- Hard Shutdown--Same as above, but immediately opens generator breaker and de-energizes the fuel solenoid.

Voltage Range Alarm

- Alarm/Shutdown point for an excess of voltage bias signal from the EGCP-2 to AVR.
- Preset to trigger at $\pm 100\%$ voltage bias output.
- Indicates that the AVR is not responding to the voltage bias output as expected.

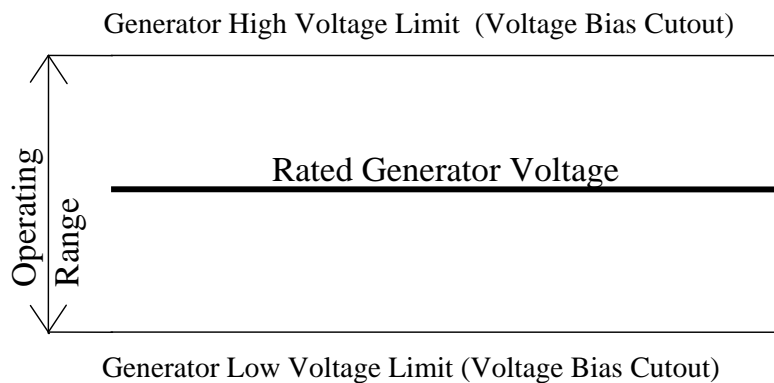

Figure 4-20. Generator High/Low Voltage Alarms

Generator Volt High Limit

- Sets maximum allowable generator voltage level.
- If voltage is above High Limit, generator is not considered stable, and is unfit for breaker closure.

Generator Volt Low Limit

- Sets minimum allowable generator voltage level.
- If voltage is below Low Limit, generator is not considered stable, and is unfit for breaker closure
- Voltage Bias will not decrease while generator voltage is below the low limit.

Generator High/Low Volt Limit Alarm

- Even if the Alarm Set Points for the High/Low Limits are Disabled, the Voltage Bias will **not** allow adjustment beyond these limits.
- The same is true for the synchronizer, which will not allow a gen breaker closure if the High or Low Voltage limits are met or exceeded for a period of time which exceeds the Gen Volt Timer Set Point. This is true even with Voltage Matching disabled.

Voltage Alarm Delay

- Sets minimum time, in seconds, allowed prior to activating either Generator High/Low Voltage Limit Alarms. This allows for short period transient over/under voltages to occur on the generator without setting off the Generator Voltage Alarms.

Generator Frequency High Limit

- Sets maximum allowable generator frequency level.
- If frequency is above High Limit, generator is not considered stable, and is unfit for breaker closure.

Generator Frequency Low Limit

- Sets minimum allowable generator frequency level.
- If frequency is below Low Limit, generator is not considered stable, and is unfit for breaker closure.

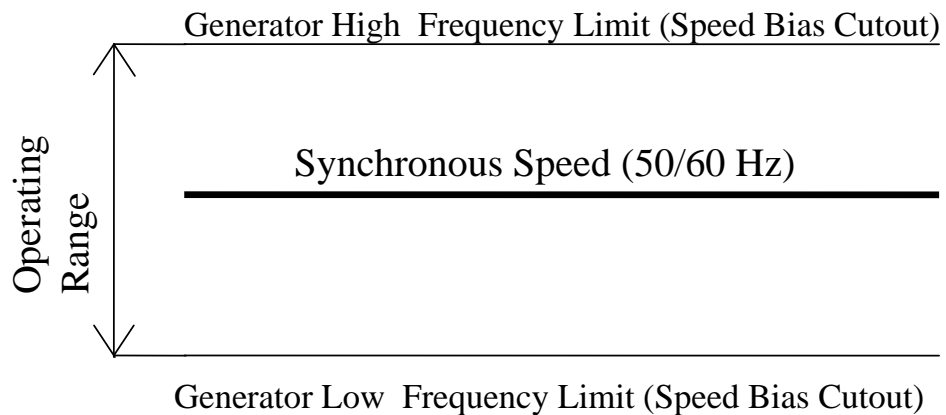

Figure 4-21. Generator Over/Under Frequency

Generator High/Low Frequency Limit Alarm

- Even if the Alarm Set Points for the High/Low Limits are Disabled, the Speed Bias will not allow adjustment beyond these limits.
- The same is true for the synchronizer, which will **not** allow a gen breaker closure if the High or Low Frequency limits are met or exceeded.

Speed/Frequency Mismatch Alarm

- Compares engine speed (MPU) to generator frequency (PT signal) and alarms on a difference.
- Used to indicate loss of MPU, or Loss of Generator Field Voltage.
- If Start Sequencing is Disabled and no MPU is present, then this alarm compares Generator Frequency to Generator Frequency, so the Speed/Frequency Mismatch Alarm will never alarm.

| | |
|--------|---|
| NOTICE | Woodward recommends that the Speed/Frequency Mismatch Alarm be set the same as the Overspeed Alarm to protect against the loss of the MPU signal. |
|--------|---|

Overcurrent Level

- Range 5.0 – 30,000 A
- Overcurrent level setting must be a greater value than the rated current of the generator
- Set for per Phase Overcurrent
3 Phase sensing, selects phase with highest current
- Uses Inverse Time Function as basis for overcurrent detection
The overcurrent is based on AMP•SECONDS.
AMP•SECONDS are determined by:

$$\text{Overcurrent Delay x (Overcurrent Level – Rated Current)}$$

- Per Phase Rated Current is determined by the Configuration menu
Voltage Input—Wye or Delta
Rated kVA
Voltage Ref
Per Phase Rated Current equals
WYE voltage input: $(\text{Rated kVA} / \text{Voltage Ref}) / 3$
DELTA voltage input: $(\text{Rated kVA} / \text{Voltage Ref}) / 1.732$

Example 1: 480 V L-L system, 277 V L-N system
110 kW Generator, 4:1 PT Ratio

| | |
|---------------------------------|---------------------------------|
| Voltage Input = Delta | Voltage Input = Wye |
| Rated kVA = 125 | Rated kVA = 125 |
| Voltage Ref = 480 V L-L | Voltage Ref = 277 V L-N |
| $(125\ 000 / 480) / 1.732$ | $(125\ 000 / 277) / 3$ |
| = per Phase Rated Current | = per Phase Rated Current |
| 150 A = per Phase Rated Current | 150 A = per Phase Rated Current |

Example:

| OVERCURRENT LEVEL | 180 A | 180 A | 180 A | 180 A | 180 A |
|-------------------|---------|---------|---------|---------|---------|
| Rated Current | 150 A | 150 A | 150 A | 150 A | 150 A |
| Delay Time | 0.1 s | 1.0 s | 5.0 s | 10 s | 20 s |
| AMP SECONDS | 3.0 | 30.0 | 150 | 300 | 600 |
| Actual Current | 170 | 170 | 170 | 170 | 170 |
| Trip Time | No Trip | No Trip | No Trip | No Trip | No Trip |
| Actual Current | 181 | 181 | 181 | 181 | 181 |
| Trip Time | 3.0 s | 30 s | 150 s | 300 s | 600 s |
| Actual Current | 190 | 190 | 190 | 190 | 190 |
| Trip Time | 0.3 s | 3 s | 15 s | 30 s | 60 s |
| Actual Current | 200 | 200 | 200 | 200 | 200 |
| Trip Time | 0.15 s | 1.5 s | 7.5 s | 15 s | 30 s |
| Actual Current | 220 | 220 | 220 | 220 | 220 |
| Trip Time | 0.075 s | 0.75 s | 3.75 s | 7.5 s | 15 s |

Table 4-1. Overcurrent Level Chart

Overcurrent Delay

- Range 0.1 – 20.0 seconds
- Used with the Overcurrent Level and Rated Current to determine the amount of time (AMP•SECONDS) any current can be greater than the overcurrent level before an alarm or shutdown is received.
- Overcurrent Detection begins when current exceeds Overcurrent Level
- AMP•SECONDS

$$\text{Overcurrent Delay} \times (\text{Overcurrent Level} - \text{Rated Current})$$

- If the Overcurrent Level is set \leq Rated Current, **AMP•SECONDS = 0**.
- This will cause an Alarm or Shutdown when Rated Current is attained.
- AMP•SECONDS accumulate when current is $>$ the Overcurrent Level
- AMP•SECONDS reset to 0 when current is $<$ the Overcurrent Level

Using Figures 4-22, 4-23, and 4-24 will help determine where the Overcurrent Level and Overcurrent Delay should be set for any application.

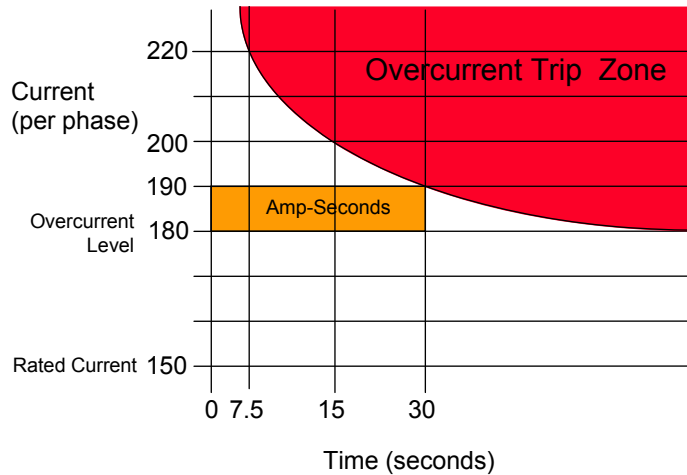

Figure 4-22. Delay Time is 10 Seconds, Current goes to 190 A, an Alarm or Shutdown will be Received in 30 Seconds

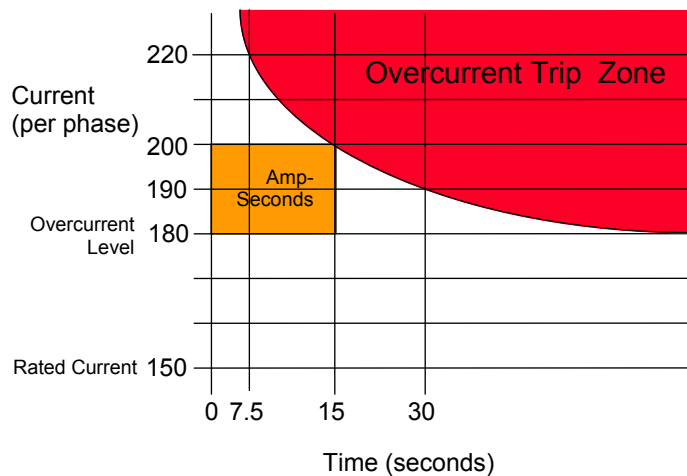

Figure 4-23. Delay Time is 10 Seconds, Current goes to 200 A, an Alarm or Shutdown will be Received in 15 Seconds

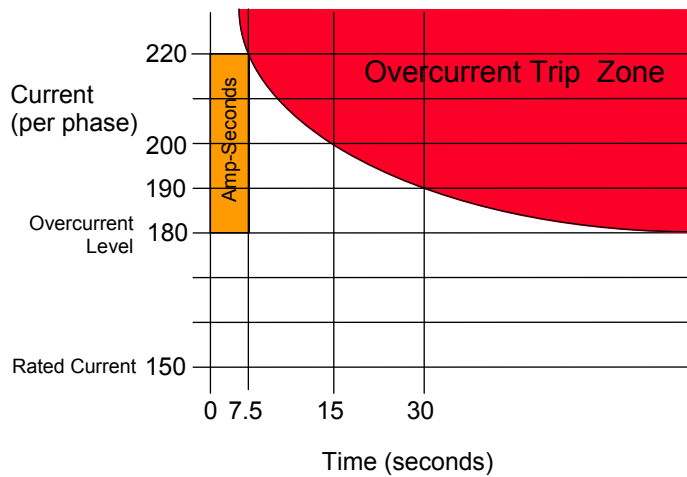

Figure 4-24. Delay Time is 10 Seconds, Current goes to 220 A, an Alarm or Shutdown will be Received in 7.5 Seconds

Overcurrent Alarm

If the Overcurrent Alarm is set for DISABLED, the Overcurrent Level and Overcurrent Delay will have no effect.

Reverse Power Level

- When the Reverse Power Level is reached, an Instant trip is received.
- Configured as a percentage of Rated kW
- Range: -1.0 through -50%

Reverse Power Delay

- Reverse Power Delay determines the amount of Reverse Power accumulation needed to cause an Alarm or Shutdown.
- Range: 0.1 – 20 seconds

Minimum Reverse Power

- The power level must exceed the Minimum Reverse Power continuously for the calculated delay time before the configured Alarm or Shutdown action is taken. Reverse power levels above (a less negative or positive power) this setting will have no effect. When the power level falls below the Minimum Reverse Power level an accumulation of reverse power is started. As the power level increases above this level, the accumulated amount will be reset to zero.
- Configured as a percentage of Rated kW
- Range: -1.0 through -50%

| Configuration Settings | |
|----------------------------|------------------|
| Rated kW | 120 kW |
| Reverse Power Level | - 10% (-12 kW) |
| Reverse Power Delay | 2 Seconds |
| Minimum Reverse Power | - 5% (-6 kW) |
| Reverse Power Value | Trip Time |
| -7 kW | 12 seconds |
| -8 kW | 6.5 seconds |
| -9 kW | 4.6 seconds |
| -12 kW | Instant |

Table 4-2. Reverse Power Chart

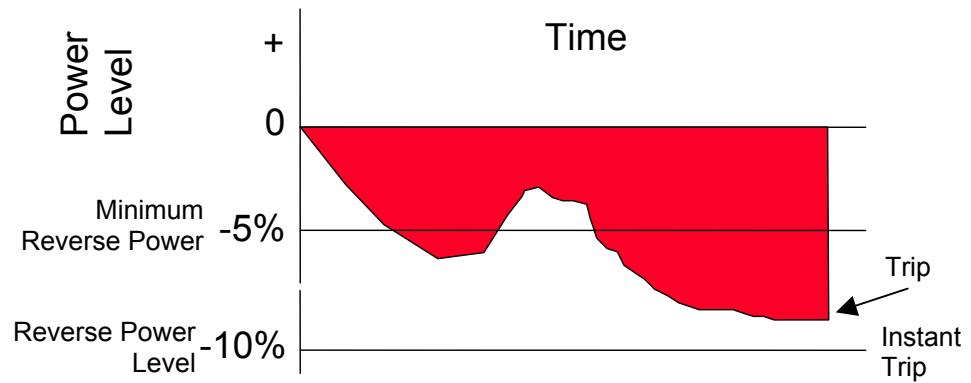

Figure 4-25. Reverse Power

Figure 4-25 shows Reverse Power. The first time the power level decreases below the Minimum Reverse Power setting does not last long enough to cause a trip. The second time the accumulating amount reaches the calculated delay and a trip is received. Dropping below Reverse Power Level would cause a trip instantly.

Reverse KVAR Limit

- Range: $-.0$ to -00
- Set as a percentage of the Rated kVAR. If the EGCP-2 senses a kVAR load greater than this value the Reverse kVAR Delay begins. When the Delay times out, an alarm will trigger.
- Used to indicate loss of field excitation to the generator.

Reverse KVAR Delay

- Range: 0.1 to 5.0 seconds.
- Provides a delay before triggering the Alarm.

Remote Faults #1 through #6

- Each fault is programmable for:
 - disabled
 - warning
 - visual alarm
 - audible alarm
 - soft shutdown
 - hard shutdown

Remote Faults #1 through #6:

- Each alarm has a programmable time delay (0 to 30 seconds).
- Each alarm can be set for any of the standard alarm or shutdown levels.
- Remote Faults 1 and 2 can have a **Stable Delay** time Enabled or Disabled. When Enabled a 15 second timer will begin after the Gen Stable period has expired.

Engine Control

Preglow Time

- Time of preglow allowed prior to engine crank cycle.
- Maintained through engine cranking.
- Resets after every crank attempt.

Crank Time

- Maximum Allowable Time for Engine Cranking.

Crank Cutout

- Engine rpm level where crank command is canceled.

Crank Delay

- Time between Engine Crank Attempts.
- This Delay is started when in the Spindown mode and the speed of the generator set has dropped below 50 rpm. Cannot restart engine until this time has expired.

Crank Repeats

- Number of times EGCP-2 will repeat its attempt to start the engine. Cranking attempts will equal the value of Crank Repeats +1.

Crank Fail

- Alarm Set Point.
- Activates when the Number of Crank Repeats is depleted.

Idle Speed

- If the Relay #12 output is configured for Idle/Rated switch, this value will set the speed at which the Idle/Rated Time begins.
- Value should be approx. 10% less than the actual idle speed of the generator set.

Idle Time

- The delay in seconds the EGCP-2 waits once the Idle/Rated Speed set point is exceeded. Once the Idle/Rated Time is passed, the EGCP-2 will energize the #12 Discrete Output (if the Relay #12 output is configured for the idle/rated function).

Cooldown Time

- Time allowed for cooldown once engine achieves a stop cycle.
- Must exceed Cooldown Limit (see next display) before activated.

Cooldown Limit

- kVA set point at which, when exceeded, will cause the engine to go to a cooldown during the next stop cycle.

Engine Run Time

- Hours of Run Time on Engine
- Increments every run hour on System Status screen display.
- Retained in non-volatile memory—Does not require power to retain its value. The memory is updated every 4 hours of continuous operation, and every time the engine is stopped.

MW Hours

- MW Hours on Generator
- Increments in 0.1 MWH on System Status screen display.
- Retained in non-volatile memory, this memory is updated every 4 hours of continuous operation, and every time the engine is stopped.

Overspeed

- Set for overspeed limit of engine.
- Typically set for 10% above Rated Speed of engine.

Overspeed Alarm

- Alarm Set Point.
- Typically configured to Hard Shutdown for safety.
- When “Start Sequencing” is Disabled, the PT signal is used to calculate the overspeed signal. No MPU is needed in this condition.

NOTICE

Woodward recommends that the Speed/Frequency Mismatch Alarm be set the same as the Overspeed Alarm to protect against the loss of the MPU signal.

Battery Volt High Limit

- Sensed DC voltage supply to EGCP-2.
- Can be used to detect faulty charging circuit.

Battery Voltage Low Limit

- Used to detect weak battery/failed charger.
- Automatically Disabled during engine cranking.

High Oil Pressure

- Uses Engine mounted pressure sensor.
- Active when generator is stable.
- Display is selectable for psi (American) or Bar (Metric).

Low Oil Pressure Pre-Limit

- Used to sense failure of lube oil system.
- Start Sequencing ENABLED, Active at 90% of Rated Speed plus 5 seconds or when Generator Breaker closes plus 5 seconds
- Start Sequencing DISABLED, Active when Fuel Solenoid output energizes plus 30 seconds or when Generator Breaker closes plus 5 seconds

Low Oil Pressure

- Used to sense failure of lube oil system.
- Start Sequencing ENABLED, Active at 90% of Rated Speed plus 5 seconds or when Generator Breaker closes plus 5 seconds.
- Start Sequencing DISABLED, Active when Fuel Solenoid output energizes plus 30 seconds or when Generator Breaker closes plus 5 seconds

High H2O Temperature Pre-Limit

- Uses engine mounted temperature sensor
- Active once Generator is stable.
- Display is selectable for degrees F (American) or degrees C (Metric).

High H2O Temperature

- Uses engine mounted temperature sensor.
- Active once Generator is stable.
- Display is selectable for degrees F (American) or degrees C (Metric).

Low H2O Temperature

- Useful for detection of failed jacket water heater.
- Always active.

Synchronizer

Synchronizer Mode

Permissive

- Acts as a synch check device.
- EGCP-2 will not issue speed or voltage bias commands, but if synchronization conditions are within spec (phase and voltage), control will issue a breaker close command.

Check

- Used for checking synchronizer prior to commissioning.
- EGCP-2 control actively synchronizes generator by issuing speed and voltage bias commands, but **does not issue breaker closure command**.

Run

- Normal operating mode.
- Actively synchronizes and **issues breaker closure command**.
- EGCP-2 control MUST be in RUN to operate as a dead bus closing device.
- In multiple unit systems EGCP-2 control MUST have AUTO input active to enable breaker control.

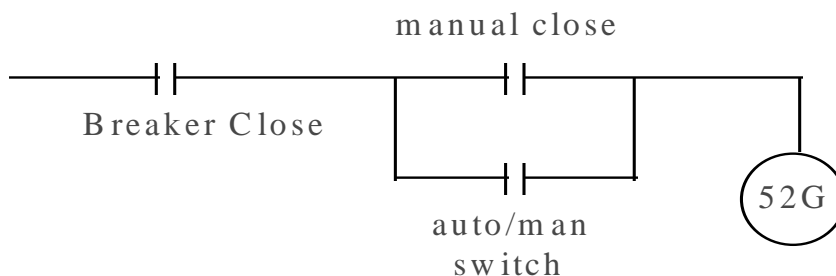

Figure 4-26. Typical Circuit Using Permissive Function and Run for Auto/Manual Synchronizing

Synchronizer Gain

- Sets Gain of Synchronizer speed bias output
 - Gain Multiplier for output signal proportional to phase error.

Synchronizer Stability

- Sets Stability of Synchronizer speed bias output.
 - Stability (Integrator dx/dt in seconds per repeat)

Voltage Matching

- Enables/Disables Voltage Matching feature of EGCP-2 control.
- Enables Voltage Window Set Point.

Voltage Window

- Overall percentage of error allowed between generator and bus, or generator and mains.
- EGCP-2 control will not issue a breaker closure if error is greater than voltage window.

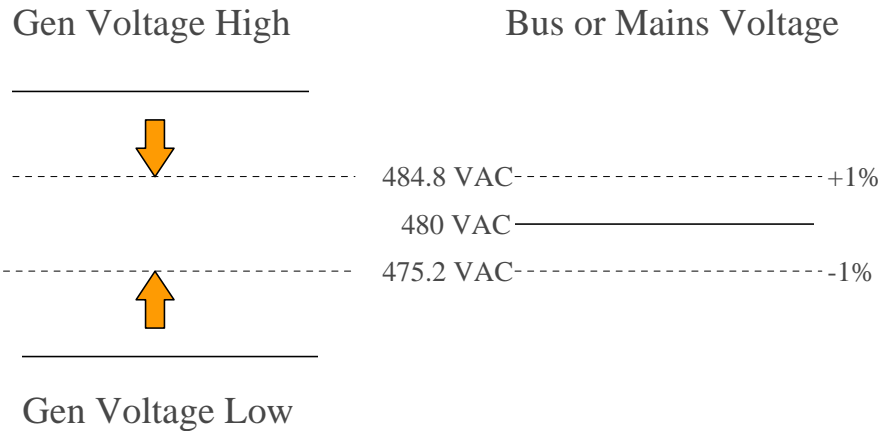

Figure 4-27. Voltage Matching (1% set point)

Max. Phase Window

- Maximum allowable phase angle deviation from phase matched condition.
- EGCP-2 Control will not issue breaker closure if phase angle between generator and bus, or generator and mains exceeds this window.

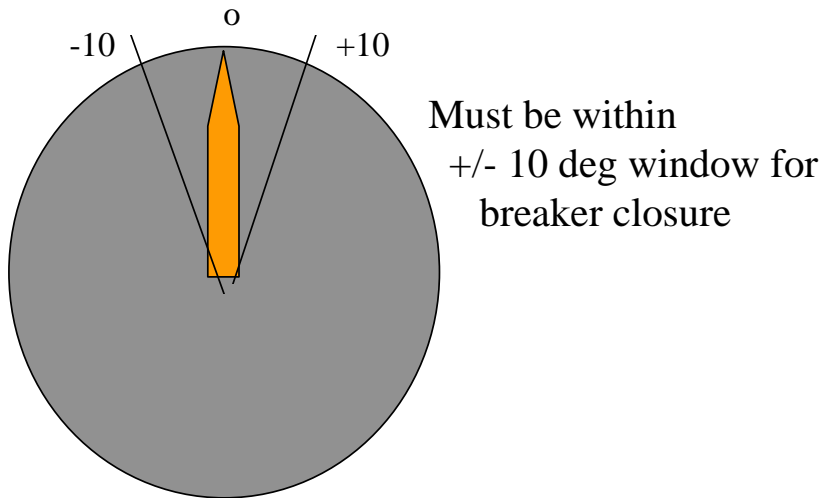

Figure 4-28. Maximum Phase Window = 10 Degrees

Dwell Time

- The period of time that the generator must be within the Max. Phase Window for before the EGCP-2 control will issue a breaker closure.
- Longer dwell times will typically give better stability after the breaker closes.
- Shorter dwell times reduce amount of time required to synchronize unit.

C.B. Hold Time

- Time in seconds that Breaker/Contactor Close output is held after breaker close command is issued.
- The Breaker/Contactor Close command is removed when the C.B. Hold Time is done, if a Generator Breaker Aux feedback is received, or if the synchronization conditions fall outside the voltage and/ or speed specifications.

Close Attempts

- Number of Close Attempts allowed while synchronizing.
- Close attempt incremented if breaker does not send back continuous CB Aux signal to EGCP-2.

Reclose Delay

- Time in seconds before EGCP-2 control attempts resynchronization after failed closure attempt.

Synch Reclose Alarm

- Alarm set point if number of close attempts is depleted.

Synchronizer Time Out

- Sets time allowed for synchronization in seconds.
- Begins timing when synchronizer activates.
- Active for all gen and mains breaker open and close commands from EGCP-2 control.
- A setting of zero (0) seconds disables synch. time-out—infinite synch time allowed.

Synch Time-out Alarm

- Sets alarm mode if synch time-out is exceeded. Shutdown actions are not allowed.

Dead Bus Closure

- Enables/Disables Dead Bus Closing Feature in a multiple unit application.
- Dead Bus Closing is always active when configured for single unit operation.
- Unit must be within voltage and frequency high/low limits to be considered for dead bus closure.
- Dead Bus Closure uses Token Passing Scheme to assure that only one unit in a networked system will close onto the dead bus at any given time.
- Multiple unit systems must be in the AUTO mode to allow dead bus closing between networked units.

Real Load Control

Load Control Mode

- **Normal**
 - Standard setting for load control and VAR/PF functions.
- **Soft Transfer**
 - Unit will issue mains breaker open command while in process control if process reference is reached, or while in base load and base load reference is reached.
 - The Test input (Discrete Input #2) must be closed to activate this feature.
- **Droop**
 - Manual Load and Voltage Control
 - Used primarily for commissioning.

Load Control Gain

- Sets gain response of load control.
- Active in load ramping and base load operations.

Load Share Gain

- Sets gain response of proportional load sharing.
- Active in load sharing operations.

Load Stability

- Sets Stability response of load control.
- Active in load ramping and base load operations.

Load Derivative

- Sets Derivative response of load control.
- Active in load ramping and base load operations.

Load Control Filter

- Low Pass Filter used to attenuate higher frequency transients for better stability.
- Active in proportional load sharing, load ramping, and base load control modes.
- Higher values of filter will tend to make the unit more responsive to small, rapid transients.
- Lower values of filter will tend to make the unit less responsive to small, rapid transients.

Base Load Reference

- Load Level that Generator will automatically ramp to when operating in Base Load.
- Must be set to a greater value than the Unload Trip Level

Unload Trip

- Load Level where Generator Breaker/Contactor open command will be issued when EGCP-2 control is off loading generator set.
- Must be set less than the Baseload Load Reference value.

Load Droop

- Percentage of kW droop used when EGCP-2 control is operating in a droop mode.

Load Time

- Time in seconds for generator to load from unload trip level to base load level. This rate is applied during any automatic loading function, including ramping to load sharing.
- The Load Time is bypassed if the EGCP-2s system load is 100% or greater.
- Example: Load Time = 10 seconds
 - Base Load Ref = 200 kW
 - Unload Trip = 25 kW
 - The difference is 175 kW
 - The EGCP-2 will ramp 175 kW in 10 seconds
 - This breaks down to 17.5 kW per second

Remember, if the Base Load Ref or Unload Trip is changed, it will affect the ramping rate when loading.

Unload Time

- Time in seconds for generator to unload from base load level to unload trip level. This ramp rate is applied during any automatic unload functions, including ramping from load sharing.
- Example: Unload Time = 10 seconds
 - Base Load Ref = 200 kW
 - Unload Trip = 25 kW
 - The difference is 175 kW
 - The EGCP-2 will ramp 175 kW in 10 seconds
 - This breaks down to 17.5 kW per second

Remember, if the Base Load Ref or Unload Trip is changed, it will affect the ramping rate when unloading.

Raise Load Rate

- Percent Load per Second ramp rate used when the Raise Load input (Discrete Input #6) or Modbus address AW40300 is used during base load operation.

Lower Load Rate

- Percent per Second Ramp Rate used when the Load Lower input (Discrete Input #7) or Modbus address AW40300 is used in base load operation.

KW Load High Limit

- Maximum allowed load while operating in Base load or Process control modes.
- Prevents overload of unit when in Base load or Process control modes.

KW High Limit Alarm

- Sets Alarm Action when unit is at or above High Load Limit.
- Active during all load control operations.
- Unit will not exceed High Limit set point when operating in Base Load or Process Control Modes.

KW Load Low Limit

- Active during all load control operations.
- Sets alarm mode when unit is at or below Gen Low Load Limit.
- Minimum allowed load while operating in Base load or Process control modes.
- Prevents reverse current of unit.

KW Low Limit Alarm

- Sets Alarm Action when unit is at or below Low Load Limit.
- Active during all load control operations.

KVA Switch Low

- Sets level, which when exceeded, will cause the kVA relay output to energize. Only applicable for units with the relay#12 function configured for kVA Load Switch.

KVA Switch High

- Sets level, which when exceeded, will cause the kVA relay output to de-energize. Only applicable for units with the relay#12 function configured for kVA Load Switch.

Summary of kVA load switch action:

If the relay 12 output is configured for kVA Load Switch action:

If the three-phase sum of the generator kVA is greater than the kVA Switch Low set point and less than the kVA Switch High set point, the K12 relay output will energize. Any other kVA levels relative to the Low and High switch set points will cause the K12 relay output to de-energize.

Reactive Load Control

VAR/PF Mode

- **Disabled**
Unit does not PF share, or control PF under any circumstances.
- **VAR Control**
Unit PF shares in isolated bus load sharing mode.
Unit controls kVAR in Base Load and Process Control Modes.
- **PF Control**
Unit PF shares in isolated bus load sharing mode.
Unit controls PF in Base Load and Process Control Modes.

VAR/PF Gain

- Controls Gain Response of unit in VAR/PF control mode.
- NOT active in PF sharing mode.

Voltage Ramp Time

- Ramp time from 0 to $\pm 100\%$ voltage bias output.
- Controls response of units in PF sharing modes.
- Controls ramp time of voltage during synchronization.
- Controls ramp time of voltage during manual voltage adjust.

VAR/PF Sharing Gain

- Controls Gain Response of unit in VAR/PF Sharing Mode.
- Not active in VAR/PF Control Mode.

VAR/PF Stability

- Controls Stability Response of unit in VAR/PF control mode.
- NOT active in PF sharing mode.

KVAR Reference

- When kVAR control mode is selected, this references the amount of kVAR the generator will produce while in Base Load or Process control modes.
- Can be set for generate or absorb levels of kVAR.
- kVAR levels limited by Rated kVAR of unit.

PF Reference

- PF level that will be maintained by the generator while in Base Load or Process control modes.
- Can be set for leading or lagging power factor.
- Scaled from -0.5 (0.5 leading) to $+0.5$ (0.5 lagging).

PF Deadband

- \pm deadband around PF reference point.
- Set in PF units.
- Active in PF and PF sharing modes.
- Can be used to stabilize units at low loads if needed.

Process Control

Process Import/Export Hardware

EGCP-2 Control can accept a 4–20 mA or 1–5 Vdc input signal from a kW transducer. Input signal conditioning is selected by a dip switch on the back of the EGCP-2 control, switch position 4, switch number 4. Closing this switch selects the 4–20 mA input hardware. Opening this switch selects the 1–5 Vdc input hardware. See the EGCP-2 layout diagram for switch location on the unit.

SW - 4

1. +5V RS-485
2. 123 ohm RS-485 Termination+
3. 123 ohm RS-485 Termination -
4. 4-20 mA Process Input

Dip Switch # 4

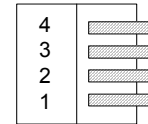

Figure 4-29. EGCP-2 Control Dip Switch

Process Dynamics

- Process Master Uses Process PID to control.
- Gain, Stability, Derivative, Filter, Droop.
- Slaves to the Process Master use Load Control PID Values to track master system load reference.

Process Action

- Defines action of speed bias when unit is operating in process control in parallel with the mains.
- Direct action = Unit increases speed bias (fuel) to increase process 4–20 mA input.
- example: Export Power control
- Indirect action = Unit decreases speed bias (fuel) to increase process 4–20 mA input.
- example: Import Power Control

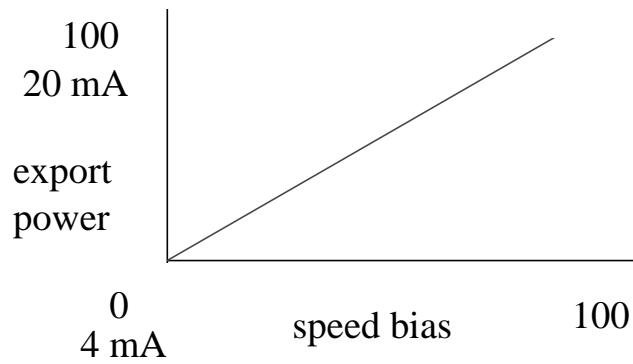

Figure 4-30. Direct (Export) Process Action

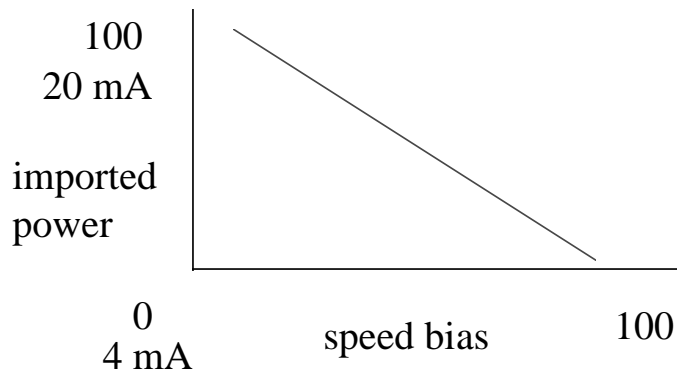

Figure 4-31. Indirect (Import Power) Process Action

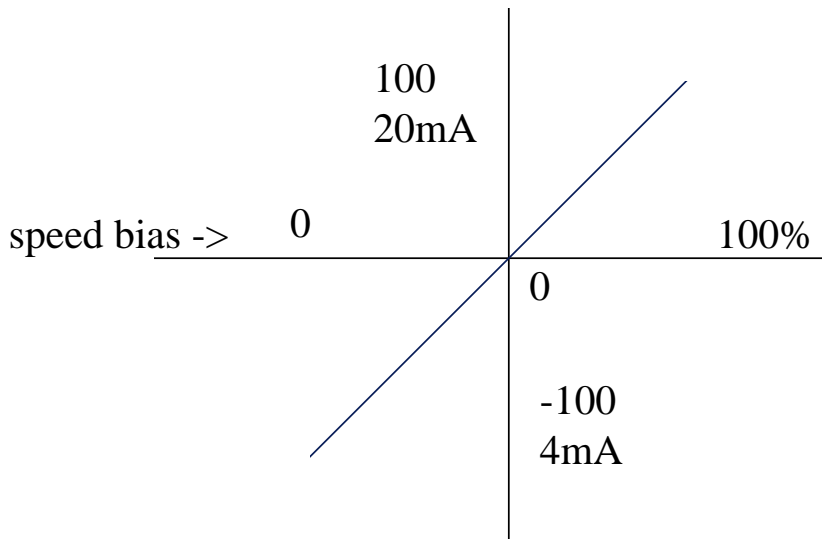

Figure 4-32. Direct (Import/Export) Process Action
(This example is using a 4–12–20 mA transducer.)

Process Gain

- Sets system gain response while in process control.
- Effective when active master unit only. Slaves rely on Load Control dynamic settings to control response to master load reference.
- Should be set with maximum number of units operating in process control mode.

Process Stability

- Sets system stability response while in process control.
- Effective at active master unit only. Slaves rely on Load Control dynamic settings to control response to master load reference.
- Should be set with maximum number of units operating in process control mode.

Process Derivative

- Sets system derivative response while in process control.
- Effective at active master unit only. Slaves rely on Load Control dynamic settings to control response to master load reference.
- Should be set with maximum number of units operating in process control mode.

Process Deadband

- Range: 0.3–5.0%.
 - This is % of full scale.
 - Full Scale is figured from the Process Low Value and Process High Value set points.
- \pm deadband around process reference point.
- Used to add stability to marginally stable process.

Process Droop

- Introduces negative feedback on the process reference as the process input increases.
- Used to add stability to marginally stable processes.

Process Filter

- Low Pass Filter attenuates higher frequency transients on process 4–20 mA input signal.
- The higher the filter is set, the more active the process control will be to higher frequency process transients.
- The lower the filter is set, the less active, and more stable the process control will be to higher frequency process transients.

Process Reference

- The reference point at which the master will control the process input.
- The reference point units are selectable under **Process Units**.
- Also used in Soft Transfer modes to set the level of process at which the transfer from mains to generator(s) will occur.

Raise Rate

- Rate, in %/s, at which the process reference will change when the EGCP-2 receives a Raise Load input (Discrete Input #6) or Modbus address AW40328 while operating in process control mode.

Lower Rate

- Rate, in %/s, at which the process reference will change when the EGCP-2 receives a Lower Load input (Discrete Input #7) or Modbus address AW40328 while operating in process control mode.

Process High Limit

- Maximum allowable process reference level.
- Dependent on **Process Units** setting.
- Effective on active master unit only.

Process High Limit Alarm

- Sets Alarm Action when process High Limit is reached.

Process Low Limit

- Minimum allowable process reference level.
- Dependent on **Process Units** setting.
- Effective on active master unit only.

Process Low Limit Alarm

- Sets Alarm Action when process reference reaches the Low Limit.

Process Units

- Allows user to configure Process Input values to be displayed in other units besides milliamps or voltage.
 - The KW Transducer signal will still be in milliamps or volts.
- This selection effects Process Configurations:
 - Process Reference
 - Process High Limit
 - Process Low Limit
 - Process High Value
 - Process Low Value
- Status screens effected
 - Discrete I/O
 - KW Load

- Engineering unit selections

| Displayed Units | |
|-----------------------|-------|
| <input type="radio"/> | Ma |
| <input type="radio"/> | V |
| <input type="radio"/> | kW |
| <input type="radio"/> | MW |
| <input type="radio"/> | kVA |
| <input type="radio"/> | MVA |
| <input type="radio"/> | kVAR |
| <input type="radio"/> | MVAR |
| <input type="radio"/> | PF |
| <input type="radio"/> | Deg C |
| <input type="radio"/> | Deg F |
| <input type="radio"/> | PSI |
| <input type="radio"/> | kPA |
| <input type="radio"/> | BAR |

Process Low Value

- The Process Input, when at 4 mA or 1.0 volt, will be displayed as.
 - Example: Process Low Value = -1000 kW
 - Process Input is 4 Ma
 - KW LOAD status screen will display: -1000 kW

Process High Value

- The Process Input, when at 20 mA or 5.0 volt, will be displayed as.
 - Example: Process High Value = 750 kW
 - Process Input is 20 Ma
 - KW LOAD status screen will display: 750 kW

Sample Process Applications with Process Units as kW and mA:

kW Transducer Input = 4-12-20 mA

4 mA = -500 kW

12 mA = 0 kW

20 mA = 500 kW

| Process Units | kW |
|--------------------|-----------------------|
| Process Action | Indirect |
| Process Deadband | 0.3 % |
| Process Ref | -50 kW (Import Power) |
| Process High Limit | 100 kW |
| Process Low Limit | -250 kW |
| Process Low Value | -500 |
| Process High Value | 500 |

| Process Units | mA |
|--------------------|------------------------|
| Process Action | Indirect |
| Process Deadband | 0.3 % |
| Process Ref | 11.5 mA (Import Power) |
| Process High Limit | 14 mA |
| Process Low Limit | 10 mA |
| Process Low Value | 4 |
| Process High Value | 20 |

Transfer Switch

Check Mains Breaker

- Used to activate checking of mains C.B. Aux. Discrete input when enabled.
- If disabled, unit relies on other units with this set point enabled to broadcast state of mains C.B. Aux. contact over network.
- Units Controlling Mains Breaker must have Check Mains Breaker Enabled.

Fast Transfer Delay

- Time required for a transition in switching from Mains to Generator operations, and from Generator to Mains operations.
- Critical for Open Transfer applications.
- The transition time between Bus and Mains sensing is 1.2 seconds.
 - With the Fast Transfer Delay set for 0.1 seconds, the transfer will take 1.3 seconds.

Mains Stable Delay

- Period of time required for the mains to be declared stable (within voltage and frequency limits for the specified time) before transition from generator(s) to mains.

Generator Stable Delay

- Period of time generator must be declared stable (within voltage and frequency limits for the specified time) before transition from Mains to Generator, as well as dead bus closing.

Load Surge

- Used only in Base Load or Process Control. **(Mains Parallel Operations)**
- Set to trigger at a percent of total generator load shift per second while operating in Mains Parallel. **(% Rated Load/Second)**
- Can be set for Loss of Mains Detection.
- Instantaneous Trigger.

Load Surge Alarm

The load surge condition will cause a response defined by this set point. The available responses are:

- Disabled
- Warning
- Loss of Mains
- Loss of Mains with Alarms

Main Volt High Limit

- Alarms when Mains Voltage exceeds Alarm Set Point.
- Alarm can be set for Loss of Mains.
- If Mains Voltage is above High Limit, Mains are not considered stable, and the EGCP-2 control will not issue a mains breaker closure command.

Main Volt High Alarm

The Main Volt High condition will cause a response defined by this set point. The available responses are:

- Disabled
- Warning
- Loss of Mains
- Loss of Mains with Alarms

Main Volt Low Limit

- Alarms when Mains Voltage drops below set point.
- Alarm can be set for Loss of Mains.
- If Mains Voltage is below Low Limit, Mains are not considered stable, and the EGCP-2 control will not issue a mains breaker closure command.

Main Volt Low Alarm

The Main Volt Low condition will cause a response defined by this set point. The available responses are:

- Disabled
- Warning
- Loss of Mains
- Loss of Mains with Alarms

Main Frequency High Limit

- Alarms when Mains Frequency exceeds Alarm Set Point.
- Alarm can be set for Loss of Mains.
- If Mains Frequency is above High Limit, Mains are not considered stable, and the EGCP-2 control will not issue a mains breaker closure command.

Main Freq High Alarm

The Main Frequency High condition will cause a response defined by this set point. The available responses are:

- Disabled
- Warning
- Loss of Mains
- Loss of Mains with Alarms

Main Frequency Low Limit

- Alarms when Mains Frequency drops below set point.
- Alarm can be set for Loss of Mains.
- If Mains Frequency is below Low Limit, Mains are not considered stable, and the EGCP-2 control will not issue a mains breaker closure command.

Main Freq Low Alarm

The Main Frequency Low condition will cause a response defined by this set point. The available responses are:

- Disabled
- Warning
- Loss of Mains
- Loss of Mains with Alarms

LOM Action Delay

- Sets Time Delay for LOM Action to begin once Loss of Mains is detected.
- Delay time From LOM detection to mains breaker open, and engine start command.
- In applications where the utility bus is somewhat unstable, this setting can be used to prevent momentary disruption of the mains frequency or voltage on from causing unwanted Loss of Mains actions to occur.

Sequencing and Comms (Communications)

Automatic Sequencing

- Enables or Disables Auto Sequencing for that unit.
 - **Disabled** and in AUTO(Discrete Input #1)
 - Will start on Loss of Mains
 - Does not start when Master Unit is put in the AUTO and Run w/Load mode
- Disabling at the master disables all auto sequencing.

Automatic Sequence Delay

- Amount of time in seconds before Auto Sequencing begins.
- Delay time starts when the Master unit closes its generator breaker.
- This insures that all generator sets have ample time to synchronize and close to the bus prior to load being added or generator sets being sequenced back offline.
- Only functions if Auto Sequencing is Enabled.

Maximum Generator Load

- % system load on all units with gen breakers closed, and on the same network, in Auto, and in Load Sharing or Process control modes, at which active master unit will begin timing to sequence next unit on line.
- Consult Chapter 5, Generator Sequencing, for details.

Next Genset Delay

- Period of time that will pass before master auto sequences an additional generator on line after the Maximum Generator Load Set Point is exceeded, and remains exceeded.
- Delay is effective only in active master unit.

Rated Load Delay

- Delay when system load exceeds 100%, before master starts next genset in sequence.
- Rated Load Delay function overrides load ramping on unit being sequenced on line. That unit will immediately assume its proportion of the system load.

Maximum Start Time

- Time allowed by master to see next unit to be sequenced on line in an “active” condition, i.e. started and ready to load.
- This is determined by a network flag, which indicates the unit is ready to load, is sent over the network by the unit being sequenced on by the master.
- If master does not detect this flag within the Max. Start Time allowed, it will go to the next lower priority unit and try starting it, or if no other units are available, it will retry the start command on the same unit.

Minimum Generator Load

- % of system load at which the Master EGCP-2 begins the Reduced Load Delay to sequence units off line.
- With only two engines operating, the Master unit will NOT sequence off the next unit if the System Load Percentage will increase above the **Max Gen Load –10%**.
- Consult Chapter 5, Generator Sequencing, for details.

Reduced Load Delay

- Time in seconds that the active master waits before sequencing units off line.
- Delay is effective only on active master unit.
- Lowest priority units are sequenced off line first.

Maximum Stop Time

- Time in seconds allowed by master for slave to sequence off line.
- Master begins sequencing next lowest priority unit off line if system load is still above Min. Gen. Load set point at the end of the Max Stop Time Limit.

422 Protocol

- This setting defines the protocol used on the EGCP-2's RS-422 port. Make sure you are familiar with the various settings by reading the Communication Manual 26181 completely before deciding on which protocol to use.

IMPORTANT

Changes in the 422 Protocol set point do not take effect until power is cycled to the control.

ServLink

- Sets RS-422 Serial Communications to ServLink Protocol

Modbus®

- Sets RS-422 Serial Communications to Modbus RTU Protocol

Upload Set Points

- Sets RS-422 Serial Communications to Upload Set Point mode.

Modbus ID

- Sets the Modbus RTU network ID of the Unit. Units will be Modbus slaves.

Modbus Timeout

- Sets the timeout time for Modbus communications. See the Communications Manual 26181 for details.

Modbus Reset

- Can be used to zero the Modbus error counts for the unit.

Calibration Menu

While each unit will be factory calibrated at Woodward prior to shipment, there are bound to be some inputs/outputs affected by external wiring and/or interfaces (relays, transformers, etc.) that will require calibration at the site during commissioning.

The Calibration Menu allows calibration of all the analog inputs to the EGCP-2, as well as the speed bias and voltage bias outputs.

All calibration points in the EGCP-2 are used to make the actual value of an input, such as generator voltage, read out on the respective display screen of the EGCP-2 the proper value of the signal being monitored.

In order to assist in calibrating the unit, each calibration menu item has the sensed input being calibrated displayed on the lower two lines of the right hand LCD screen. These values are updated every 200 milliseconds. All adjustments in the configuration menus are immediate in their action (that is, values do not need to be entered into memory to have an effect on the sensed input, or control operation).

Example: 380 Vac measured line to line on the generator A-B phase should read 380 Vac in the line to line voltage measurement area of the EGCP-2 “generator status” menu. The EGCP-2 is configured for Line to Line voltage input.

The calibration menu item “PT Phase A Scale” will display the A-B generator phase voltage in the lower two lines of the display. This value will change as the PT Phase A Scale value is adjusted.

Process Input Scale

- Measure the actual Process Input Signal from external transducer.
- Calibrate the Process Input Scale until the Process Input, bottom line on display screen, reads what the measured process signal is.

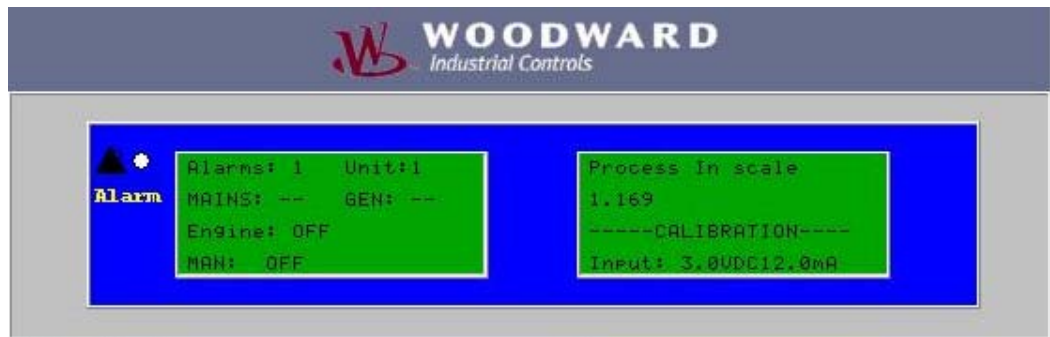

Figure 4-33. Process In Scale

Measured vs Monitored

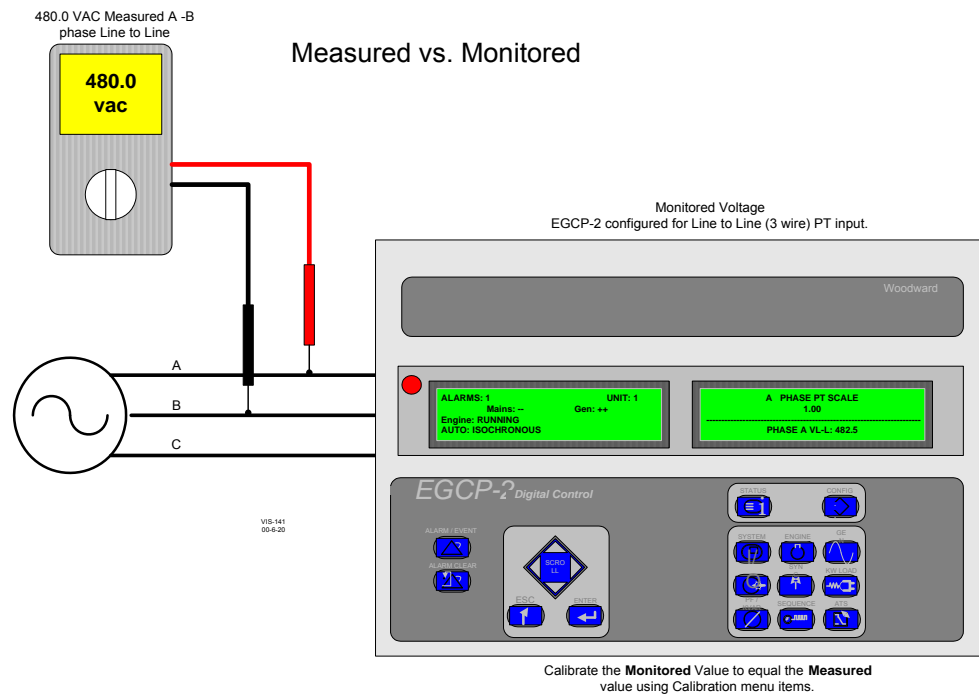

Figure 4-34. Measured vs. Monitored

Speed Bias Offset

- Range: 50% to –50% of selected Speed Bias Type
- Factory calibrated for:

| Speed Bias Type | Voltage at Terminals 73(+) – 74(-) | Speed Bias Offset |
|-----------------|---------------------------------------|-------------------|
| ±3 Vdc | 0.00 Vdc | 0.0% |
| 0.5 – 4.5 Vdc | 2.5 Vdc | 0.0% |
| PWM | 50% Duty Cycle | 0.0% |

- Adjust the Speed Bias Offset to obtain rated frequency for the generator set

```
Speed Bias Offset
-0.42 %
-----CALIBRATION-----
Hz: 60.0
```

- Calibration is required for Caterpillar's ADEM speed control.
 - PWM range needs to be calibrated for 69% Duty Cycle as measured on Terminals 73(+) and 74(-).
 - Preset Speed Bias Offset to 39.00%

```
Speed Bias Offset
39.00 %
-----CALIBRATION-----
Hz: 0.0
```

- Start Engine
- Adjust Speed Bias Offset for rated speed of 50 or 60 Hertz.
- Press the Enter key to save the final setting

Voltage Bias Offset

- Range: 50% to –50% of selected Speed Bias Type.
- Factory calibrated for:

| Voltage Bias Type | Voltage at Terminals 37(+) – 38(-) | Volts Bias Offset |
|-------------------|---------------------------------------|-------------------|
| ±1 Vdc | 0.00 Vdc | 0.0% |
| ±3 Vdc | 0.00 Vdc | 0.0% |
| ±9 Vdc | 0.00 Vdc | 0.0% |

- Adjust the Volts Bias Offset to obtain rated voltage for the generator set.

```

Volts Bias Offset
  0.05 %
-----CALIBRATION-----
GEN A VL-L   0.0
    
```

- Measure the actual generator voltage
 - Follow connection procedure in Appendix D for the Voltage Regulator being used
 - What Voltage Bias Type to use
 - Where to preset the Volts Bias Offset
- Press the Enter key to save the final Volts Bias Setting
- The EGCP-2 control will always reset to the saved Volts Bias Offset value when the generator breaker is opened.
- Whenever the Generator set is started or taken offline, it will control at the rated voltage when calibrated correctly.

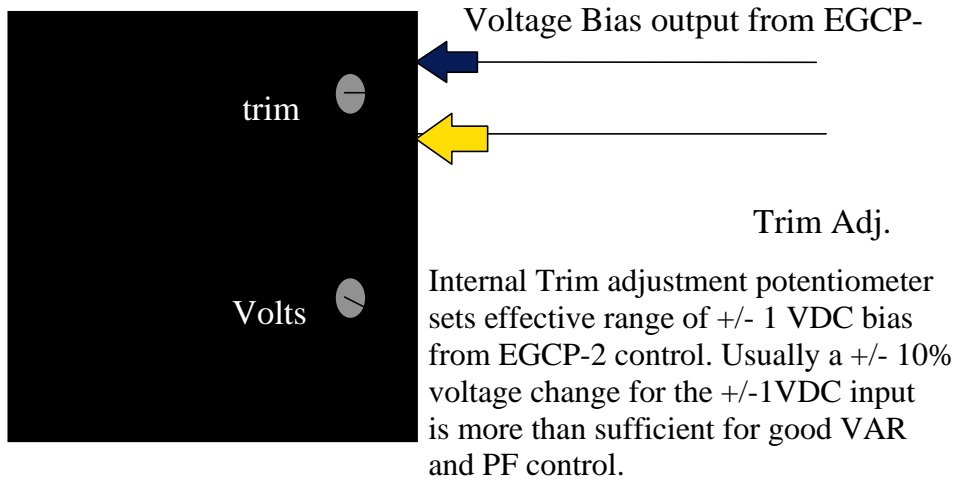

Figure 4-35. Typical AVR with Aux Input (Newage SX-440)

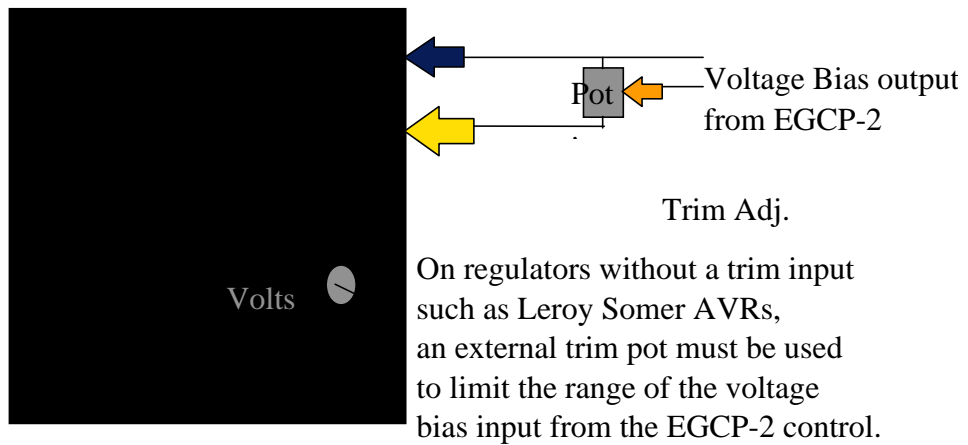

Figure 4-36. Typical AVR with External Voltage Adjust Potentiometer

AVR DROOP

- It is **highly recommended** to fit the AVR with a Droop CT input, and utilize a medium droop level on the AVR. This adds stability to the AVR for VAR/PF sharing at low loads.
- Cross current compensation must be disabled in the AVR Droop CT circuit.

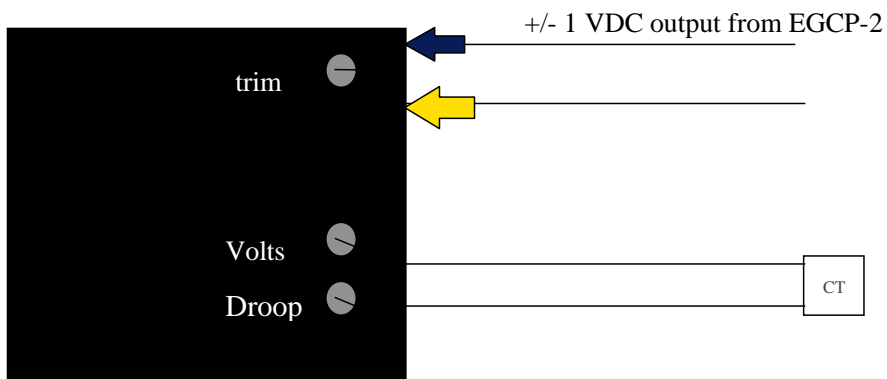

Figure 4-37. AVR Droop

PT Phase A Scale

- Calibrates PT phase A voltage.
- Adjust PT Phase A Scale until the monitored value matches the measured generator voltage on A phase.

```
PT Phase A Scale
  2.582
-----CALIBRATION-----
GEN A UL-L  480.0
```

PT Phase B Scale

- Calibrates PT phase B voltage.
- Adjust PT Phase B scale until the monitored value matches the measured generator voltage on B phase.

PT Phase C Scale

- Calibrates PT phase C voltage.
- Adjust PT Phase C scale until the monitored value matches the measured generator voltage on C phase.

CT Phase A, B and C Offset

- Calibrates CT Phase A, B, or C input sensing of EGCP-2 at zero current.
- Only calibrate when generator is operating with no load.
- Calibrate within ± 0.3 of 0.0 A.
- Measure actual generator currents with clamp on ammeter, or panel ammeter. Verify 0 A on the selected phase input.
- Calibrate selected phase CT reading in the calibration window.

```
CT Phase A Offset
-26.00
-----CALIBRATION-----
A AMPS: -0.1
```

CT Phase A Scale

- Calibrates CT Phase A
 - Do NOT calibrate if generator load is under 50% of Rated.
 - Factory calibration will be within 1%.
- Load generator to above 50% of Rated load
- Measure actual generator currents with clamp on ammeter or panel ammeter.
- Adjust until monitored current equals measured current.

```
CT Phase A scale
3.04
-----CALIBRATION-----
A AMPS: 70.0
```

Calibrating the Phase A CT for 70 A

CT Phase B Scale

- Calibrates CT Phase B
 - Do NOT calibrate if generator load is under 50% of Rated.
 - Factory calibration will be within 1%.
- Load generator to above 50% of Rated load
- Measure actual generator currents with clamp on ammeter or panel ammeter.
- Adjust until monitored current equals measured current.

CT Phase C Scale

- Calibrates CT Phase C
 - Do NOT calibrate if generator load is under 50% of Rated.
 - Factory calibration will be within 1%.
- Load generator to above 50% of Rated load
- Measure actual generator currents with clamp on ammeter or panel ammeter.
- Adjust until monitored current equals measured current.

Bus PT Scale

- Calibrates Mains/ Bus PT input.
- This input can be calibrated using the Mains Pt or the Bus PT.
- Mains PT calibration
 - Measure the Mains voltage
 - Adjust scale until Mains monitored voltage equals the mains measured voltage.



Synchronizer Status Screen

Calibration Menu

Calibrating Bus PT Input using the Mains PT Input

- Bus PT calibration
 - Measure the Bus voltage. If the BUS is dead no calibration can be done.
 - To get the EGCP-2 to switch from monitoring the Mains to monitoring the Bus, the generator must be started.
 - Configure Synchronizer Mode for CHECK
 - Close Discrete inputs AUTO and Run w/Load to start engine.
 - Adjust Bus PT Scale until monitored voltage equals measured voltage

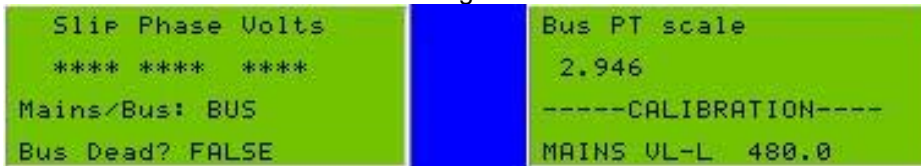

Synchronizer Status Screen

Calibration Menu

Calibrating Bus PT Input using the Bus PT Input

Synchronizer

- Calibrates phase angle error detection of EGCP-2.
- Factory calibrated for zero phase angle error between bus and mains A phase (depending on synchronizing operation) and A phase generator inputs.
- With synchronizer in “check” mode, and a live bus, monitor the synchroscope menu of the EGCP-2 for “phase angle”.
- Monitor Voltage across open gen contactor/breaker or panel synchroscope for phase angle error between generator and bus.
- Adjust synchroscope calibration for lowest voltage across gen breaker, or 12 o'clock reading on panel mounted synchroscope.

Battery VCO Gain

- Adjustment to match the monitored High battery voltage with the measured High battery voltage.
- This monitors the input supply voltage on terminals 1 and 2.
- Battery voltage Gain is calibrated for accurate High Battery Voltage Alarms

Battery VCO Offset

- Adjustment to match the monitored Low battery voltage with the measured Low battery voltage.
- Battery voltage Offset is calibrated for accurate Low Battery Voltage Alarms.

Adjusting Battery Gain and Offset

- Use an adjustable power source
- Measure the input supply voltage being fed from the power source
- Set the power source for 28 volts DC
- Adjust the Gain until the monitored voltage reads 28 volts
- Set the power source for 10 volts
- Adjust the Offset until the monitored voltage reads 10 volts
- Repeat these steps until no adjustment is needed

Oil Pressure Gain

- Oil pressure sensor input, terminals 68(+) and 69(-).
- **Factory Calibrated for a 0–75 psi signal over a 4–20 mA range.**
 - 4 mA = 0 psi
 - 20 mA = 75 psi
- Designed to accept a 4–20 mA or 1–5 volt transducer or a passive resistive type, 0 – 200 Ω .
- Sensors can have a Direct or Indirect relationship
 - Direct – Increase in resistance, mA, or volts is an Increase in Pressure
 - Indirect – Increase in resistance, mA, or volts is a Decrease in Pressure
- Direct type – Gain will be a **Positive value**
 - 4 mA = 0 psi, 20 mA = 100 psi
 - 1 volt = 0 psi, 5 volt = 100 psi
 - 0 Ω = 0 psi, 200 Ω = 100 psi
- Indirect type – Gain will be a **Negative value**
 - 4 mA = 100 psi, 20 mA = 0 psi
 - 1 volt = 100 psi, 5 volts = 0 psi
 - 0 Ω = 100 psi, 200 Ω = 0 psi
- Resistive sensors are commonly a direct relationship.
- Adjust the Oil Pressure Gain, the Calibration menu will provide a monitored reading that will be compared to a measured reading.
- Adjust gain until EGCP-2 monitored reading matches actual reading.

```
Oil Press Gain
0.0176
-----CALIBRATION-----
Oil Press: 100. PSI
```

Example of a Direct type sensor

Oil Pressure Offset

- Set to read 0 psi or bar when engine is shut down.
- Gain and Offset **will** affect each other, so it is necessary repeat these steps until no adjustment is needed.

```
Oil Press Offset
-20.64
-----CALIBRATION-----
Oil Press: 0.0 PSI
```

Example of a Direct type sensor

Adjusting Oil Pressure Gain and Offset

Example of a Passive Resistive sensor:

- Disconnect the sensor from the EGCP-2 and measure the resistance coming from the sensor both when the engine is (1)shut down and (2)running at rated speed.
- Record the pressure and resistance.
- Then connect a potentiometer or decade box to the EGCP-2 oil pressure input, terminals 68 and 69.
- Set the resistance for the running value.
- Adjust the Oil Pressure Gain until the Calibration reading matches the desired reading.
- Set the resistance for the shutdown value.
- Adjust the Oil Pressure Offset until the Calibration reading shows 0 psi or bar.
- Repeat these steps until the EGCP-2 reads correctly with no further adjustment to the Gain or Offset values.

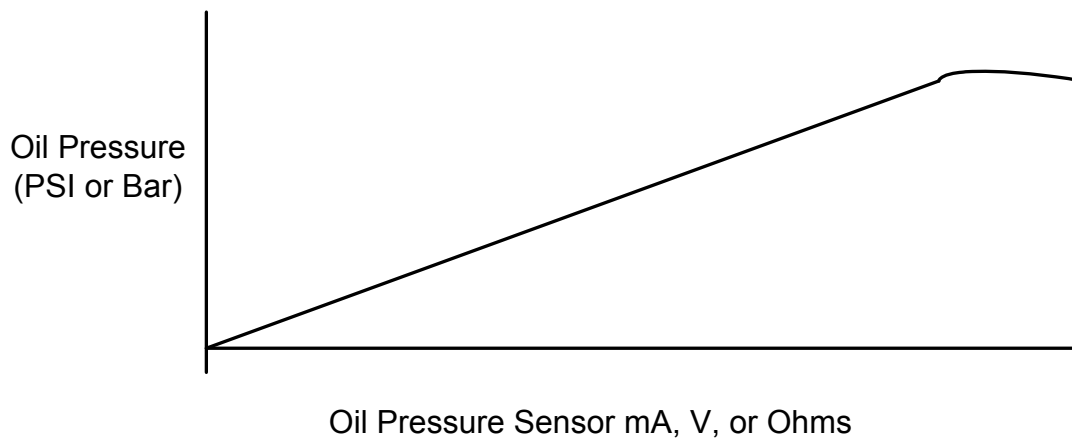

Figure 4-38. Oil Pressure Sensor Curve

Water Temperature Gain

- Water temperature sensor input, terminals 66(+) and 67(-).
- **Factory Calibrated for 0–300 °F over a 4–20 mA range.**
- Designed to accept a 4–20 mA or 1–5 volt transducer or a passive resistive type, 0–500 Ω .
 - If the passive resistive sensor is greater than 500 Ω , it may be necessary to add one or more of the shunt resistors (DIP switch 2) to achieve the temperature range.
- Sensors can have a Direct or Indirect relationship
 - Direct – Increase in resistance, mA, or volts is an Increase in Temperature
 - Indirect – Increase in resistance, mA, or volts is a Decrease in Temperature.
- Direct type – Gain will be a **Positive value**.
 - 4 mA = 0 degrees (OFFSET), 20 mA = 212 °F (GAIN)
 - 1 volt = 0 degrees (OFFSET), 5 volts = 212 °F (GAIN)
 - 0 Ω = 0 degrees (OFFSET), 500 Ω = 212 °F (GAIN)
- Indirect type – Gain will be a **Negative value**.
 - 4 mA = 212 degrees (OFFSET), 20 mA = 0 °F (GAIN)
 - 1 volt = 212 degrees (OFFSET), 5 volts = 0 °F (GAIN)
 - 0 Ω = 212 degrees (OFFSET), 500 Ω = 0 °F (GAIN)
- Resistive sensors are commonly an indirect relationship.
- If the sensor or transducer has an **Indirect relationship**
 - Adjust the Gain for the water temperature when the engine is shut down.
- If the sensor or transducer has a **Direct relationship**
 - Adjust the Gain for the engine's operating temperature.
 - High H2O temperature.
- To adjust the Water Temperature Gain, the Calibration menu will provide a monitored value that will be compared to a measured reading.
- Adjust gain until EGCP-2 monitored reading matches actual reading.
- If it is not possible to reach the high or low temperature, it may be necessary to add one or more of the shunt resistors by closing the DIP switch 2, switch 2, 3, or 4, on the EGCP-2.

```

Water Temp Gain
0.0276
-----CALIBRATION-----
H2O Temp:212.0  ||
  
```

Example of a Direct type sensor

Water Temperature Offset

- **Direct relationship**
 - Adjust to read water temperature when engine is shutdown
 - Low H2O temperature.
- **Indirect relationship**
 - Adjust to read water temperature when engine is running.
 - High H2O temperature.
- Gain and Offset **will** affect each other, so it is necessary to repeat these steps until no adjustments are needed.

```

Water Temp Offset
-51.84
-----CALIBRATION-----
H2O Temp: 0.1  █ █

```

Example of a Direct type sensor

Adjusting Water Temperature Gain and Offset

Example of a Passive Resistive sensor.

- Disconnect the sensor from the EGCP-2 and measure the resistance coming from the sensor both when the engine is shut down (at least 12 hours) and running at rated speed, with temperature stabilized.
- Record the actual temperature and the resistance coming from the sensor at those temperatures.
- From these readings you know if the sensor is a Direct or Indirect type.
- **Direct type**
 - Connect a potentiometer or decade box to the EGCP-2 water temperature input, terminals 66 and 67.
 - Verify DIP switch #2 settings.
 - Set the resistance for the running at rated speed.
 - Adjust the **Water Temperature Gain** until the monitored reading matches the desired reading.
 - Set the resistance for the shutdown value.
 - Adjust the **Water Temperature Offset** until the monitored reading matches the desired reading.
 - Repeat these steps until the EGCP-2 reads correctly with no further adjustment at both the shutdown and running values.
- **Indirect type**
 - Connect a potentiometer or decade box to the EGCP-2 water temperature input, terminals 66 and 67.
 - Verify DIP switch #2 settings.
 - Set the resistance for the running at rated speed.
 - Adjust the **Water Temperature Offset** until the monitored reading matches the desired reading.
 - Set the resistance for the shutdown value.
 - Adjust the **Water Temperature Gain** until the monitored reading matches the desired reading.
 - Repeat these steps until the EGCP-2 reads correctly with no further adjustment at both the shutdown and running values.

Water Temperature adjustments for Resistive Sensors

In some cases the sensor has a curved shaped characteristic that cannot be matched exactly by the EGCP-2. In these situations it will be necessary to calibrate the EGCP-2 for the two most important readings, such as the high and low alarm points. In between these points there might be a slight error in reading as shown in Figure 4-39, but the reading will be correct at the two critical points.

The shunt resistors can be added to increase the degree of curve used in the EGCP-2. Closing both SW 3&4 adds a 50 ohm parallel resistance to the sensor, which causes the steepest degree of curve. With no shunt resistors closed the curve is less steep, but limited in range to 500 Ω or less.

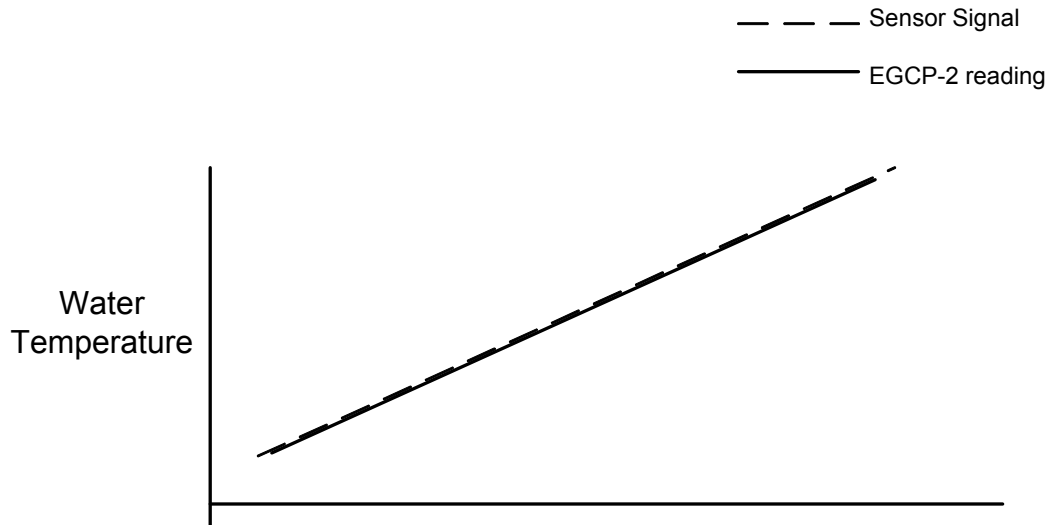

Water Temperature mA or V Transducer

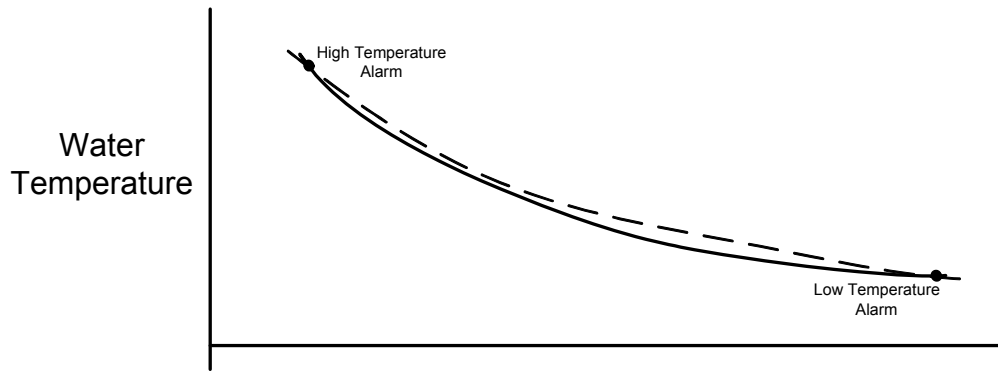

Water Temperature Resistive Sensor (Ohms)

Figure 4-39. Water Temperature Curves

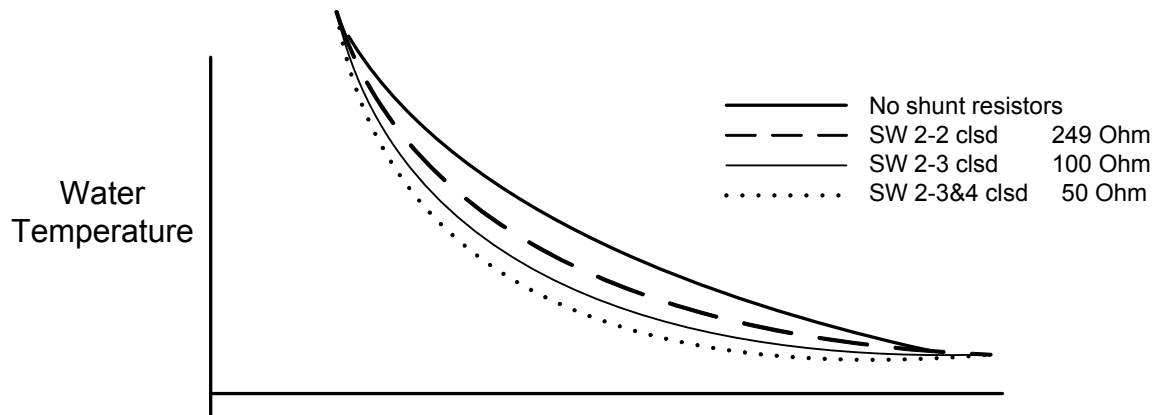

EGCP-2 Curve Characteristic

Figure 4-40. EGCP-2 Water Temperature Characteristics

Suggested Sensors and Calibration Settings

Oil Pressure sensor

| | |
|-----------------------------|-------------------------------|
| Manufacturer | VDO |
| Model | 360-xxx |
| Range | 0-80 psi |
| Dip Switch setting | 1-closed 2-open 3-open 4-open |
| *Oil Pressure Offset | -12.07 |
| *Oil Pressure Gain | 0.026 |

Water Temperature sensor

| | |
|---------------------------|---------------------------------|
| Manufacturer | VDO |
| Model | 323-xxx |
| Range | 100-250 deg F. |
| Dip Switch setting | 1-closed 2-closed 3-open 4-open |
| *Water Temp Offset | 123.15 |
| *Water Temp Gain | -0.027 |

*—These are the suggested settings for this sensor only. Woodward recommends that once installed, with the generator set operating at rated speed and the temperature stabilized, the high oil pressure and high water temperature settings be checked against an external water temperature and oil pressure reading. Adjust the appropriate setting if needed.

NetComm Dropouts

- The number of lost or corrupted network communications tolerated by the receiving unit.
- Excess numbers of NetComm Dropouts on network due to faulty wiring, improper shielding, or improper setup will result in the unit experiencing the dropouts to flash intermittently in the Sequencing Menu of the EGCP-2. Typically set at 5 to 10 dropouts.

Unit Calibrated

- When set for true, indicates unit has been factory calibrated. Requires Level 4 Security code to change.

Chapter 5.

Control Features and Functions

Engine Control

- Programmable Auto Start on Loss of Mains
- All units in Auto Mode with Loss of Mains detection enabled start and assume load.
- Multiple Crank Repeat Set Point
- Crank Repeat Timer
- Crank Fail Alarm/Shutdown
- Crank Cutout (rpm)
- Preglow
- Idle/Rated Relay

Engine Protection

- Oil Pressure
- Over/Under Alarm/Shutdown Settings
- Water Temperature
- Over/Under Alarm/Shutdown Settings
- Battery Voltage
- Over/Under Alarm/Shutdown Settings
- Overspeed
- Alarm/Shutdown Settings

Generator Voltage and Reactive Load Control

- VAR or Power Factor Load Control in Mains Parallel Operation
- Power Factor Sharing in Load Sharing, No Parallel Operation
- Externally Adjustable VAR/PF Reference
- Manual Voltage Control Capability

Generator Protection

- Over/Under Voltage
- Overcurrent
- Reverse Current
- Loss of Excitation
- Over/Under Frequency
- Stable Generator Determined by being within Voltage and Frequency Limits for a given period of time.
- kVA Load Switch

Mains Sensing

- Over/Under Voltage
- Over/Under Frequency
- Load Surge
- Programmable for Alarm/Loss of Mains Detect
- Loss of Mains Action Timer
- Stable Mains determined by being within Voltage and Frequency Limits for a given period of time

Synchronizing

- Phase Match Synchronization
- 3 Mode Operation
- Run, Check, Permissive
- Voltage Matching
- Dead Bus Closing
- Synch Timer
- Reclose Attempt/Timer
- Manual Synchronization Capability (permissive mode)

Load Control

- Proportional Load Sharing
- Integrating Base Load and Process Control
- Load Ramping
- Remote Contact Inputs to change Base Load and Process Set Points with Raise/Lower ramp rates
- Unload Trip point
- Droop Load Control Capability

Sequencing

- Each Unit in the system has an assigned Priority.
- Master (Highest Priority) automatically sequences units on or off line as determined by system load.
- Higher priority units are sequenced on in order of their priority; taken off in reverse of priority.
- System Load set point determines percent system load level at which additional units will be brought on, or taken off line.
- Time set points determine period of delay for sequencing units on/off line.
- Separate time delay for overload (100% +) system load levels so additional units can be sequenced on line quickly.

Engine Cranking

The EGCP-2 Control is designed to automatically control the cranking functions of the engine generator set. In order to safely control engine cranking the EGCP-2 uses the following set points, as found in the Engine Control tuning menu of the software:

| | |
|--------------|---------------|
| Preglow Time | Crank Delay |
| Crank Time | Crank Repeats |
| Crank Cutout | |

The description of the above items is found in the Tuning Screens section of this manual in the Configuration Menu list.

Starting Sequence:

Upon receiving a start command the following events occur:

1. The Preglow Output Energizes for the given preglow time delay, and remains energized through the crank cycle.
2. After the preglow time expires, the Fuel Solenoid output energizes.
3. 200 ms after the Fuel Solenoid output energizes, the Crank output energizes.

At this point, the engine should be cranking at a certain rpm, and receiving fuel. Typically a start would occur in these conditions. To check if a start does occur, the EGCP-2 monitors the magnetic pickup from the engine. If the magnetic pickup input indicates that the engine is operating above the Crank Cutout speed, the EGCP-2 will remove the Crank and Preglow outputs, leaving the fuel solenoid energized. The engine state in the control overview menu changes from "OFF" to "RUN".

If for some reason the engine does not reach the crank cutout rpm level, the EGCP-2 will crank the engine for the Crank Time. If the engine fails to rise above the crank cutout level in this time, the EGCP-2 will remove the Crank output signal, wait for the Crank Delay, and if allowed by the number of Crank Repeats, will crank the engine again (RETRY). This sequence will continue until the number of crank repeats is depleted, or until the engine speed rises above the crank cutout rpm setting, whichever comes first. If the number of crank repeats is depleted, the EGCP-2 will activate the Crank Fail Alarm Output based on this Alarm set point's configuration.

IMPORTANT

The preglow output may stay energized between crank attempts if the preglow time is greater than the sum of the Crank Time and Crank Delay timers.

IMPORTANT

Set Crank Repeats to zero when starting the engine for the first time with the EGCP-2. This will prevent starter and ring gear damage to the engine if the MPU input to the control should be faulty. Monitor Engine Overview Status menu on the first start and confirm the rpm readout during cranking. After a successful start is made, the crank repeats may be set to the appropriate value for the application.

Idle/Rated Relay Output

The EGCP-2 can be configured to provide a relay output, which will signal the engine electronic speed control to change from idle to rated speed operation. When configured for this output, Discrete Output 12 will energize to provide the idle to rated indication.

The idle to rated indication takes place after a successful start (generator above crank cutout speed) has occurred, the engine is operating at, or above the idle speed set point, and the idle delay time set point has expired.

Generator Voltage Control

The EGCP-2 has the ability to control the voltage of the generator set. This ability is used to control four separate operations that require generator voltage adjustment:

1. Manual voltage adjustment
2. Voltage Matching during Synchronization across the generator or mains breaker
3. Reactive Load sharing between multiple units on an isolated bus
4. Reactive Load control while in parallel with the mains.

The generator voltage, or reactive load (depending on the operation) is adjusted by injecting a voltage bias signal to the Automatic Voltage Regulator. The EGCP-2 can be set for ± 1 Vdc, ± 3 Vdc, and ± 9 Vdc outputs. The span of the output is selected by the "Voltage Bias Type" configuration menu item in the EGCP-2.

Select the proper voltage range input as recommended by the AVR manufacturer.

Generator Voltage can be manually controlled from the Voltage Raise and Voltage Lower Discrete inputs to the EGCP-2. The rate of change for manual voltage adjustment is set in the Reactive Load Control tuning menu, at the Voltage Ramp Time set point. The voltage ramp time is the amount of time it will take for the EGCP-2 to send a 0 to 100%, or 0 to -100% voltage bias signal to the AVR.

When operating in the TEST mode, manual voltage adjustment is only allowed through the voltage raise and lower inputs. This allows testing of the Voltage Bias output, and generator voltage levels prior to operation with load on the generator.

When operating in Isoch mode, the EGCP-2 does not allow manual adjustment of the voltage, unless the Load Control set point in the Configuration tuning menu is set for "Droop", or the VAR/PF Control Set Point in the Reactive Load Control tuning menu is set to "Disabled". Using either of these settings implies that a manual voltage control will be used, and no automatic reactive load control functions are active.

IMPORTANT

It is highly recommended that the automatic reactive load control in the EGCP-2 be used for proper power conditioning throughout the generator(s) load range. This is achieved by setting the Load Control set point in the Configuration tuning menu to Normal, or Soft Transfer (depending on the application), and the VAR/PF Control set point in the Reactive Load Control tuning menu to VAR or PF control (depending on the application). For more details on these functions see the Real Load Control and Reactive Load Control sections of this manual.

The percent level of the voltage bias output can be monitored in the I/O status screen of the EGCP-2. This is a useful point to monitor during initial start of the unit. By issuing Voltage Raise and Lower inputs to the control while operating in the Test Mode, confirmation of proper generator voltage levels at various voltage bias points can easily be made. Typically the generator voltage should change no more than $\pm 10\%$ for a $\pm 100\%$ voltage bias output from the EGCP-2.

All other modes of generator set operation rely upon the Reactive Load Control functions of the EGCP-2. See the information in the "Reactive Load Control" section of the manual for more details on voltage and reactive load control.

Generator Load Control

Power Sensor Theory of Operation

The digital signal processing (DSP) power measurement technique used by the EGCP-2 control involves periodic sampling of the voltage and current over an integral number of waveforms. The microprocessor computes the product of the voltage and current samples, then sums and averages the products to give a computation of power.

Load Sensor Hardware Description

The digital load sensor gets timing information from the generator A phase voltage signal. Voltages proportional to the voltage and load current for each phase are routed to the sample-and-hold circuits of the A/D converters. The simultaneous sampled values representing voltage and current are held when a conversion-store signal is received from the microprocessor. Each input is then converted and an interrupt is generated when all inputs are converted. The microprocessor then reads the digital values from A/D registers. This procedure is repeated at regular intervals to provide input for further signal processing.

To provide accuracy in the presence of noise and harmonics on the inputs, multiple samples of each waveform over a number of cycles of the input are taken to get the power measurement.

The EGCP-2 Control has four core modes of generator load control operation. These four modes are:

- Droop
- Isochronous Load Sharing
- Base Load
- Process Control

The specific mode of generator control that the unit is in at any given time can be monitored on the Control Overview status screen.

Here is a description of each of these load control modes, and the various operating states that will put the EGCP-2 into each respective load control operation.

Droop

Droop Load Control in the EGCP-2 uses the sensed kW on the generator to provide negative feedback to the speed reference of the speed control governor through the speed bias output. This will result in a decrease in generator frequency as the load is increased while operating as a single unit on an isolated bus. Increasing the Speed Raise input while operating in this manner will increase the speed of the engine gradually, thereby increasing the frequency of the generator set.

While operating in parallel with the mains, droop operation provides kW load control of the generator through the speed raise and speed lower inputs to the EGCP-2. Since the mains determine the frequency of the generator, changing the speed reference while in parallel with the mains causes a change in kW produced.

Droop load control is typically only used during commissioning of the EGCP-2. It allows complete manual control of the generator load while in parallel with the mains.

The EGCP-2 can be operated in Droop if the Real Load Control menu item “Load Control Mode” is configured for kW Droop or if the unit is operated with the Generator CB Aux input open while connected to a load, or to the mains. No other operations, or software set points can change the droop load control mode setting.

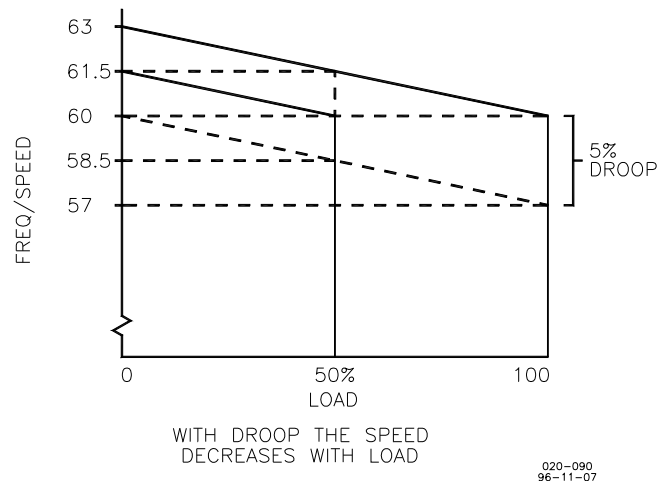

Figure 5-1. Droop Mode

Isochronous

Isochronous means repeating at a single rate or having a fixed frequency or period. A generating set operating in the isochronous mode will operate at the same set frequency regardless of the load it is supplying up to the full load capability of the generator set, as illustrated in Figure 5-2. This mode can be used on one generator set running by itself in an isolated system.

020-091
96-11-07

Figure 5-2. Isochronous Mode

The isochronous mode can also be used on a generator set connected in parallel with other generator sets. Unless the generator set controls have the capacity for load sharing and speed control, no more than one of the generator sets operating in parallel can be in the isochronous mode. If two generator sets operating in the isochronous mode, without load sharing capability, are tied together to the same load, one of the units will try to carry the entire load and the other will shed its entire load. In order to share load with other units, some additional means must be used to keep each generator set from either trying to take or shed the entire load.

Droop/Isochronous Load Sharing on an Isolated Bus

Droop/Isochronous combines the first two modes. All generator sets in the system except one are operated in the droop mode. The one unit not in droop is operated in the isochronous mode. It is known as the swing machine. In this mode, the droop machines will run at the frequency of the isochronous unit. The droop and speed settings of each droop unit are adjusted so that each generates a fixed amount of power as illustrated in Figure 5-3. The output power of the swing machine will change to follow changes in the load demand.

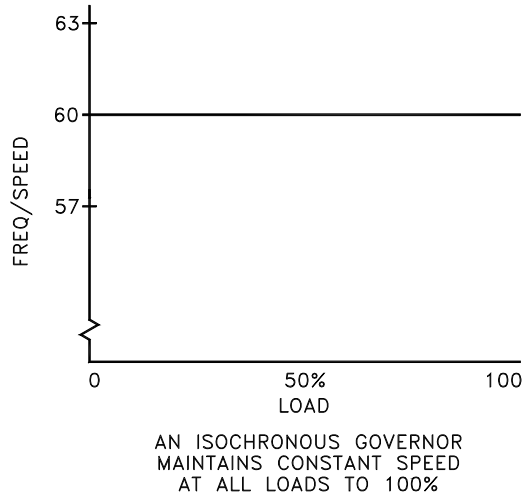
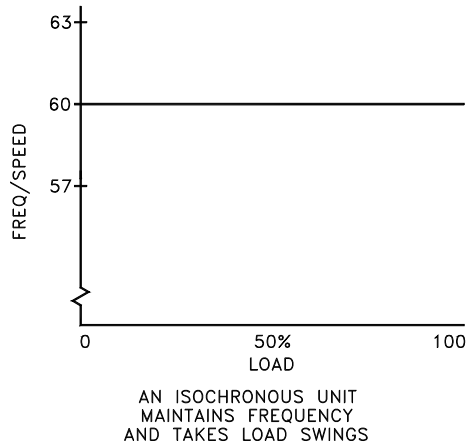

020-093
96-11-07

Figure 5-3. Droop/Isochronous Load Sharing

Maximum load for this type of system is limited to the combined output of the swing machine the total set power of the droop machines. The minimum system load cannot be allowed to decrease below the output set for the droop machines. If it does, the system frequency will change, and the swing machine can be motorized.

The machine with the highest output capacity should be operated as the swing machine, so that the system will accept the largest load changes within its capacity.

Isochronous Load Sharing on an Isolated Bus

Isochronous Load Sharing is the most common means of paralleling multiple generators together to a common load on an isolated bus. The EGCP-2 uses Isochronous Load Sharing control when operating in a Multiple Unit mode with the Load Control Mode in either Normal or Soft Transfer. Isochronous load sharing operates all generator sets in a system in the isochronous mode. Load sharing is accomplished by using the load sensor of the EGCP-2 to bias the speed reference of the isochronous governor. The EGCP-2 load sensors are connected by inter-control RS-485 network. In the case of the EGCP-2 control, Isochronous Load Sharing is done digitally via this network. Any imbalance in load between units will cause a change to the regulating circuit in each governor. While each unit continues to run at isochronous speed, these changes force each machine to supply a proportional share of power to meet the total load demand on the system.

Base Load Against the Mains

Base Load is a method of setting a base or fixed load on a machine operating in parallel with the mains. The EGCP-2 control operates the generator set in base load whenever the generator is in parallel with the utility, unless a process control mode of operation is selected through the Process discrete input. This is accomplished by using an isochronous load control and providing a reference level at which to control the load. The governor will force the generator output to increase or decrease until the output of the load sensor is equal to the reference setting. The base load reference is set in the Real Load Control tuning menu of the EGCP-2. At this point, the system is in balance.

The advantage of base loading over droop is that when separating from a Mains, there is no frequency change. Simply removing the bias signal required to maintain the base load reference on breaking from the Mains (mains CB Aux open) returns the system to isochronous load control.

The EGCP-2 is only allowed to parallel with the mains in a Mains Parallel operating mode. When configured for this type of operation, the EGCP-2 will operate in either a base load or process control mode while in parallel with the mains. The EGCP-2 automatically switches between base load and isochronous operation depending upon whether or not the Mains Breaker CB Aux input is closed at the same time the Generator CB Aux input is closed. If both the Mains and the Generator CB AUX are closed, then the EGCP-2 realizes it is in parallel with the mains, and operates in a base load control mode. The EGCP-2 will operate in a process control mode, which is discussed later in this section, if both the Process and Run with Load discrete inputs are active (on).

Automatic Generator Loading Functions

The automatic generator loading functions of the EGCP-2 control will work with the speed control to automatically control the loading and unloading of the generator. This accomplishes a bumpless transfer when paralleling the generator to a load sharing or infinite bus system, or when separating a generator from a system.

Process Control Description

The process control function of the EGCP-2 control will control any process where the controlled parameter is determined by the generator load, and the controlled parameter can be monitored as a 4–20 mA or 1–5 Vdc input signal.

The control compares the Process Input signal to the Process Reference set point in the Process menu of the EGCP-2. This set point uses milliamps for units, so that it is easily related to the 4–20 mA or 1–5 Vdc input signal. The EGCP-2 then adjusts the generator load to maintain the desired value. The EGCP-2 will only operate in a process control mode if it is configured to be a Mains Parallel unit, and receives an Auto, Run With Load, and Process discrete inputs. Also, the EGCP-2 can operate in a process soft transfer mode if the Load Control Mode set point in the Real Load Control menu is set for Soft Transfer, and the Test discrete input is closed with the Auto, Run with Load and Process discrete inputs. In a soft transfer mode, the EGCP-2 will load the generator(s) (depending on the application) to the process reference level. Upon reaching the reference value on the 4–20 mA or 1–5 Vdc input signal, the EGCP-2 will open the mains breaker. This Soft Transfer mode is used to transfer the supply of power for the load from the mains to the generator(s).

In process control mode, the Raise Load and Lower Load Discrete Inputs operate on the process control reference. The ramp rates for these Raise and Lower Load inputs are set in the Process menu, at the Process Raise and Process Lower Rate. These two set points are scaled in % per second.

When the process function is initially selected, the reference is set equal to the internal process reference. If the process input and process reference are not equal, the control ramps the load reference in the appropriate direction to reduce the difference. When the process error reaches zero, the process control is enabled.

When the process control is enabled, the error signal between the process reference and process signal is routed to a PID (Proportional, Integral, Derivative) controller operating in cascade with the load control. The output of the controller is a load reference, which is limited by the kW Load High and Low Limit set points in the Real Load Control menu. This prevents the generator from being overloaded or reversed powered to achieve its reference point.

In a multiple unit, mains parallel configuration, the master unit (lowest numerical priority) operates as the **Process Master**. The master unit must receive the 4–20 mA, or 1–5 Vdc process input signal. The master unit will control all slave units, which are in Auto mode to maintain the process reference of the master. The slave units operate in a load sharing mode in which the total system load is equally divided between the units in proportion to their rated load capacity. The master will also automatically sequence slave units on and off as required to maintain the process reference.

The Process Master controls the slave units by increasing or decreasing the System Load signal. The System Load is a 0 – 100% signal. If the Process Master receives a Hard Shutdown fault, it will open its breaker and shutdown. The slave units are now receiving a 0% System Load signal, and will operate at the kW Load Low Limit setting.

The Process Master EGCP-2 will not automatically pass the Master flag. When operating multiple units in Process control there are ways to pass the Master. To pass the Master to a slave unit, the slave unit must have the same discrete inputs (Auto, Run w/Load, and Process) as the Master.

1. Pass the Master by changing the priority of the slave to 1. The EGCP-2 will pass the Master to the slave, and if the new Master has the same process reference setting there will be no noticeable change.
2. Pass the Master by removing the Auto input from the present Master. This is the recommended way to pass the Master when the present Master receives a shutdown fault. An external device will have to recognize that the Master is shutdown and that there is another EGCP-2 that is available to be the Master. The generators will unload to their kW Load Low Limit settings, and as soon as the Master changes, the new Master will load the units until the Process reference setting is achieved.

The Process Reference point can be scaled in any one of 14 selectable Process Units. The Process Units selection can allow the operator to see the Process Reference value in kW or MW instead of milliamps. The Process Low and High Value will need to be configured whenever a different Process Unit is selected. The Process Unit will also change the Process Reference, Process Low Limit, and Process High Limit.

Additional features of the process control are an adjustable process input signal filter and adjustable deadband on the integrator. The adjustable filter allows reducing bandwidth when controlling a noisy process such as experienced in digester gas fuel applications. The deadband is useful in noisy applications as well as for very slow processes.

The process control function is configurable for direct and inverse action. Direct process control is where the sensed input signal increases as the load increases (such as where the sensed input is exhaust pressure or export power). An inverse action control is where the sensed input signal decreases as the load increases (such as when controlling import power where the import power will decrease as the generating system picks up more of the local load).

Reactive Load Control Description

When a small generator is paralleled with a Mains, the synchronizer voltage matching function adjusts the generator voltage to match that of the Mains. Voltage variations that may occur in the Mains system after paralleling can cause large changes in reactive current in the generator. The VAR/Power Factor Control provides closed loop control of either VARs or power factor when operating in parallel with another power system when that system can accept the reactive load.

Voltage adjustment, however, can only affect reactive power when another system is available to accept the reactive load. So the VAR/Power Factor control functions are automatically switched to Power Factor sharing when either single or multiple units are operating in isochronous load sharing mode on an isolated bus (Mains Breaker is open).

The VAR/PF control mode of operation is selected by setting the VAR/PF Control Mode set point in the Reactive Load Control tuning menu. When either VAR or PF control mode is selected, the control function is enabled whenever the Generator CB Aux contact is closed, and the control is configured for either Normal or Soft Transfer Load Control. VAR/PF control is overridden when the Load Control Mode is set for Droop operation. The VAR/PF control can be disabled by setting the VAR/PF Control Mode set point to Disabled. The voltage bias output is reset to 0% when the generator breaker is opened.

IMPORTANT

If cross-current compensation is installed on the voltage regulator, it must be removed prior to using the VAR/PF mode of control, or instabilities may result. The droop CT must remain connected to the voltage regulator.

Voltage Trim Control

The EGCP-2 control will perform a Voltage Trim function when configured for Single unit or if it's the only Multiple unit operating on an isolated bus. The Voltage Trim function will control the generator set at the Voltage Reference setting (Configuration menu) when on an isolated bus.

The conditions for Voltage Trim to activate are:

- Single Unit
 - Isolated bus
 - VAR/PF Mode cannot be Disabled
- Multiple Unit
 - Isolated bus
 - Only unit operating
 - VAR/PF Mode cannot be Disabled

VAR Control

The VAR control adjusts generator voltage to maintain a constant reactive power (kVAR) load on the generator throughout the kW operating range while the generator is in parallel with the mains. This assures sufficient excitation of the generator field under all load conditions. A set point is provided to set the desired VARs. The VAR control function may be enabled with VAR/PF Control mode selection set point. The kVAR reference may be changed once the generator is in parallel with the mains by issuing a raise/lower voltage contact input to the EGCP-2. Raising the kVAR reference will raise the voltage bias output to the voltage regulator, which will cause VARs to be exported to the Mains. Lowering the VAR reference will decrease the voltage bias output to the regulator that will cause VARs to be absorbed from the utility.

Power Factor Control

The power factor control adjusts generator voltage to maintain a constant power angle throughout the kW operating range while the generator is in parallel with the mains. A set point is provided for the desired power factor reference. The power factor control function may be enabled with the VAR/PF Control mode selection set point. The PF reference may be changed once the generator is in parallel with the mains by issuing a raise/lower voltage contact input to the EGCP-2. Raising the PF reference will raise the voltage bias output to the voltage regulator, which will cause the PF to move in an increasing lagging PF angle. Lowering the PF reference will decrease the voltage bias output to the regulator that will cause PF to move in an increasing Leading PF angle.

Power Factor Sharing

When either VAR or Power Factor Control is selected, and the EGCP-2 control is operating in isochronous load sharing mode, power factor sharing is automatically selected. Power factor sharing adjusts the voltage regulators so that all generators carry the same proportion of reactive load by balancing the power factor on all units. A voltage reference set point is provided to define the system operating voltage. Multiple EGCP-2 controls operating in Power Factor Sharing mode will trim their respective voltages to share the reactive load on the isolated bus, and operate around the voltage reference setting.

Synchronizer Description

Synchronization, as normally applied to the generation of electricity, is the matching of the output voltage waveform of one alternating current electrical generator with the voltage waveform of another alternating current electrical system. For the two systems to be synchronized and connected in parallel, five conditions must be considered:

- the number of phases in each system
- the direction of rotation of the phases
- the voltage amplitudes of the two systems
- the frequencies of the two systems
- the phase angle of the voltage of the two systems

The first two conditions are determined when the equipment is specified, installed, and wired. The synchronizer matches the remaining conditions (voltage, frequency, and phase) before the paralleling breakers are closed.

Functional Description

This section describes how generator and bus matching occurs and how all conditions are verified by the synchronizer functions.

Operating Modes

The EGCP-2 control is capable of synchronizing across both the generator and mains breakers, depending on the application of the generator set, and the configuration of the EGCP-2. An EGCP-2 configured for No Parallel operation will never allow the generator and mains breakers to be closed at the same time, and therefore does not synchronize across the mains breaker. Units configured for Mains Parallel operation will actively synchronize the generator, or in the case of a multiple unit system, generators, to the utility before closing the utility tie breaker.

The EGCP-2 monitors the A phase of the generator and compares this with either the A phase of the Bus PT input, or the A phase of the Mains PT input. The Bus PT input is switched through DO7 (local bus connect). The Bus PT is always monitored whenever the EGCP-2 is synchronizing, or dead bus closing across the generator breaker. Bus PT sensing is a momentary condition as the EGCP-2 will always return to sense the Mains PT input by switching to DO8 (Mains Disconnect) whenever generator synchronization is complete. Switching to the Mains PT allows the EGCP-2 to monitor for a loss of mains condition when operating on a generator that is not synchronizing across its generator breaker.

IMPORTANT

In systems that operate in parallel with the mains, or with loss of mains detection modes, it is recommended that each EGCP-2 unit in that system receive the Mains and Bus PT inputs for proper operation.

The synchroscope tuning menu is used to configure the synchronizing action of the EGCP-2. The software tuning items in the synchroscope menu apply to both the generator breaker/contactors and mains breaker/contactors synchronizing functions.

The operation of the synchronizer is determined by the three different operating modes available in the EGCP-2. The three modes are Run, Check, and Permissive.

Run mode allows normal synchronizer operation and breaker closure signals. The speed bias signal (explained below) is maintained throughout the breaker closure signal. When the specified closure signal time has elapsed and the CB (circuit breaker) Aux contact closure signal is received at the EGCP-2, the synchronizer is disabled. The synchronizer is reset automatically once the generator is taken off load and its generator breaker is opened.

Check mode allows normal synchronizing and voltage matching, but does not issue a breaker closure signal.

Permissive mode enables the synch-check function for proper synchronization, but synchronizer operation does not affect the engine's speed or generator voltage. If phase, frequency, and voltage are within proper limits for the specified dwell time, the synchronizer issues the breaker closure command.

Dead Bus Closing

When a dead bus is detected and dead bus closing mode is enabled in a multiple unit system, the synchronizer will attempt to get an exclusive lock on permission to issue a breaker closure command. This security is required to prevent two or more units from closing their breakers at the same time. To provide this security, a network message requesting the lock is made to all other EGCP-2 controls currently active on the network.

When an EGCP-2 control receives a lock request, it does the following actions:

1. If a dead bus permission request is not also currently being made, a dead bus condition is indicated, and the GENERATOR AUX CONTACT discrete input is inactive (the EGCP-2 control returns a reply message to the requesting unit).

IMPORTANT

The GENERATOR AUX CONTACT open requirement backs up the dead bus condition in the event of a bus PT failure. If a dead bus condition is indicated by lack of bus voltage, but the generator breaker is closed, a reply will not be sent.

2. If a dead bus permission request is also being made and that request sequentially precedes the received request, the received request is retained, otherwise the reply is sent. (In the event of a sequential tie, the unit with the lower assigned network address wins.)

When all other units have replied verifying that they also indicate a dead bus (bus input less than 40 Vac) and do not hold a lock, the requesting unit then holds lock permission and may attempt to close its circuit breaker. The lock is released automatically after issuing the circuit breaker closure command. This will allow any other unit to get permission to lock if the breaker fails to close.

The dead bus closing function may be enabled or disabled by the user with the Dead Bus Closure set point in the Synchroscope tuning menu.

Voltage Matching

The voltages of the generators in a parallel system must be matched within a small percentage to minimize the reactive power flow in the system. If two synchronous generators of unequal voltage are paralleled, the combined voltage will have a value different from the voltage generated by either of the generators. The difference in voltages results in reactive currents flowing in the system with subsequent lowered system efficiency.

If a synchronous generator is paralleled to a larger system such as a Mains, a difference in voltages before paralleling will not change the voltage of the bus. If the generator voltage is lower than the bus voltage, reactive power will be drawn from the bus and used to excite the generator to the higher bus voltage.

In the case where the generator voltage is low enough, the reactive power flow could motorize the generator with potential damage to the generator windings.

The microprocessor then computes the RMS values of the voltages. The processor issues appropriate adjustment of the voltage bias signal if used, to the voltage regulator to bring the generator voltage within the specified window above the bus voltage. To guarantee that reactive power will be generated, window range is from equal to bus voltage to the specified percentage above bus voltage.

The automatic voltage matching function may be enabled or disabled with a set point. When enabled, voltage matching will occur in both the Check and Run modes and is verified only by the sync-check function in Permissive mode. When enabled at an EGCP-2 control that is monitoring and controlling the mains breaker, the voltage matching will occur across both the generator and mains breaker prior to the synchronizer issuing a breaker close command when paralleling the generator(s) to the mains.

Phase Matching Synchronizing

The phase matching synchronizing mode corrects the frequency and phase of the generator to lock it to the bus frequency and phase. The microprocessor uses signal processing techniques to derive the difference in phase of the generator A and bus A phase voltage signals. When there is a difference, the synchronizer sends a correction signal to the speed control. The correction signal from the speed bias output increases or decreases engine speed depending on whether the slip is faster or slower than the bus. A PI (proportional, integral) controller provides the correction signal. Gain and Stability adjustments to the PI controller are provided to allow stable operation of the automatic synchronizer function over a wide range of system dynamics.

Synch-Check

The synch-check function determines when all conditions for proper synchronization are satisfied and energizes the breaker closure relay. The generator and bus voltage comparison is made if the voltage matching function is enabled. The generator voltage must be within the specified voltage window above bus voltage before the breaker closure command may be given.

To minimize transients, the breaker must be closed when the phase difference between the generator and bus is near zero. Also, maintaining the phase angle error between the generator and the bus within a specified Max Phase Window for a specific Dwell Time allows the synchronizer to be configured for a wide range of synchronizing conditions. The Max Phase Window and Dwell Time set points are found in the Synchroscope tuning menu of the EGCP-2.

A larger Max Phase Window, and Shorter Dwell time would typically be used on emergency standby sets, where rapid synchronization is needed. The larger window and shorter dwell time make the synchronizer less sensitive to transients in generator frequency and phase angle error when compared to the bus the generator is synchronizing to. When all conditions of voltage and phase are met, then the breaker closure command is given.

A smaller Max Phase Window and Longer Dwell Time would be used on generating systems where smooth and precise synchronization is required, and the time to synchronize is not as critical as would be seen in a standby application. A smaller window and longer dwell time require the generator to be within closer frequency and phase angle error tolerance when compared to the bus the generator is synchronizing to. When all conditions for voltage and phase are met, then the breaker closure command is given.

Multiple Shot Reclosing

The multiple shot reclosing function allows multiple closing attempts. The control provides set points for the number of **Close Attempts** and the **Reclose Delay** time. Failure to get closure after the specified number of attempts triggers the **Sync Reclose Alarm** and locks out the synchronizer by setting it to the auto-off mode. Clearing the alarm condition, in the Alarm/Event Log, will reset the synchronizer.

Synchronizer Timing

The time line diagrams below illustrate the various timing sequences the synchronizer function uses when paralleling single and multiple units across the generator or mains breaker (depending on application).

SYNCHRONIZER TIME LINE

STANDARD SEQUENCE: SYNC TIMEOUT ACTIVE (>0 sec.)

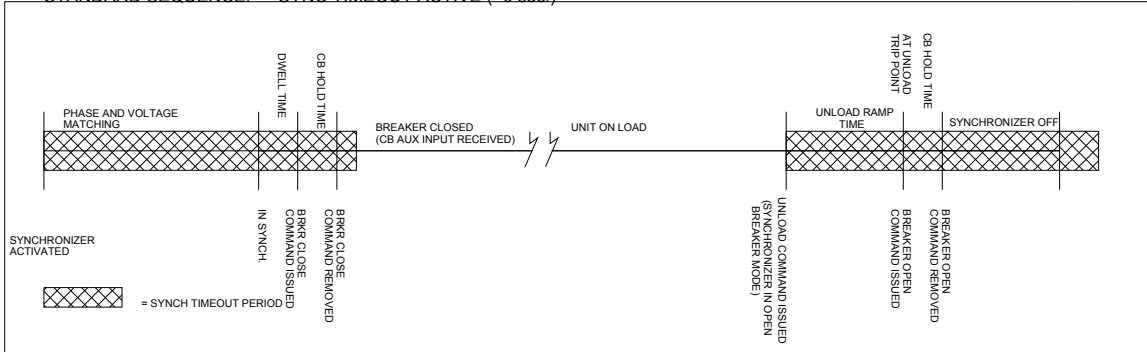

WITH RECLOSE ATTEMPTS : SYNC TIMEOUT ACTIVE AND EXCEEDED

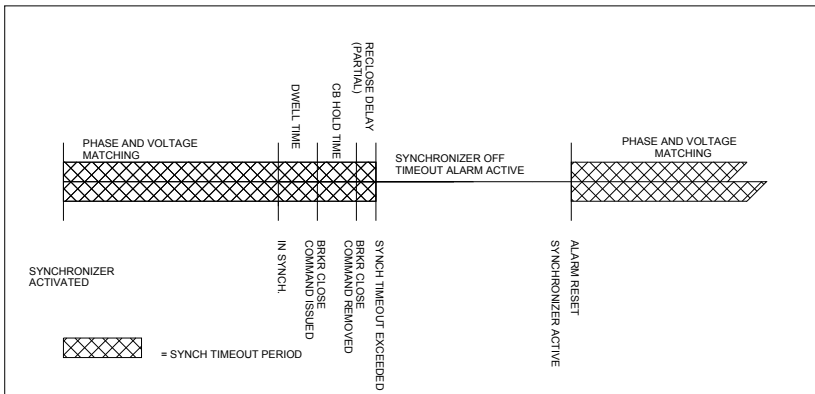

Figure 5-4. Synchronizer Time Line—Standard Sequence

Loss Of Mains Detection and Action

The EGCP-2 can be configured to detect a loss of mains condition, and respond to that condition by isolating the mains from the load, and transferring the supply of power to the load from the mains to on site engine generator sets.

The EGCP-2 can be configured for single or multiple unit, no parallel or mains parallel system operation, which will detect a loss of mains. The loss of mains action is a combination of synchronizing and load control functions of the EGCP-2. These functions allow the EGCP-2 controls to operate effectively upon a loss of mains condition.

Below are timing diagrams for mains parallel and no parallel systems. These time lines apply to the master control in multiple unit systems, or to any single unit application.

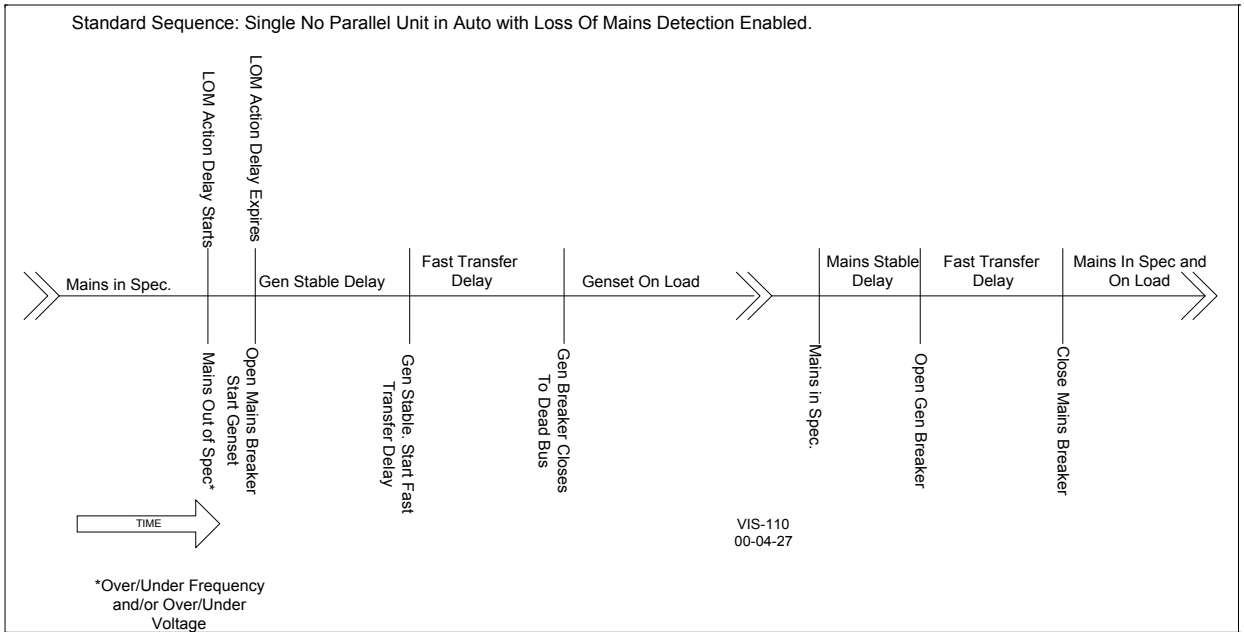

Figure 5-5. Loss of Mains Detection Active

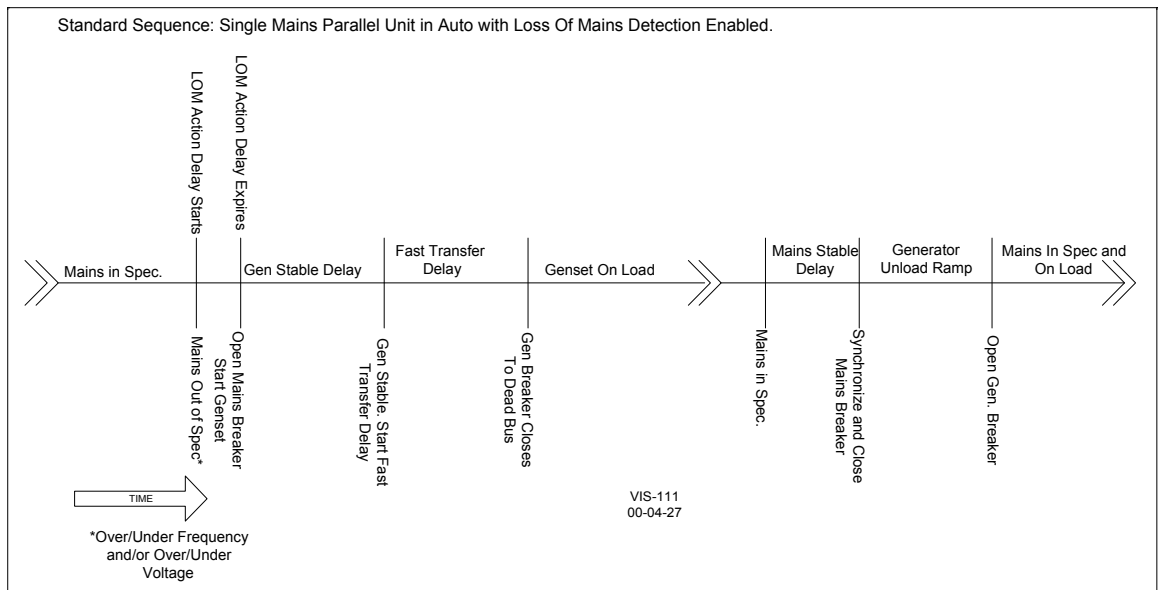

Figure 5-6. Generator Off Line

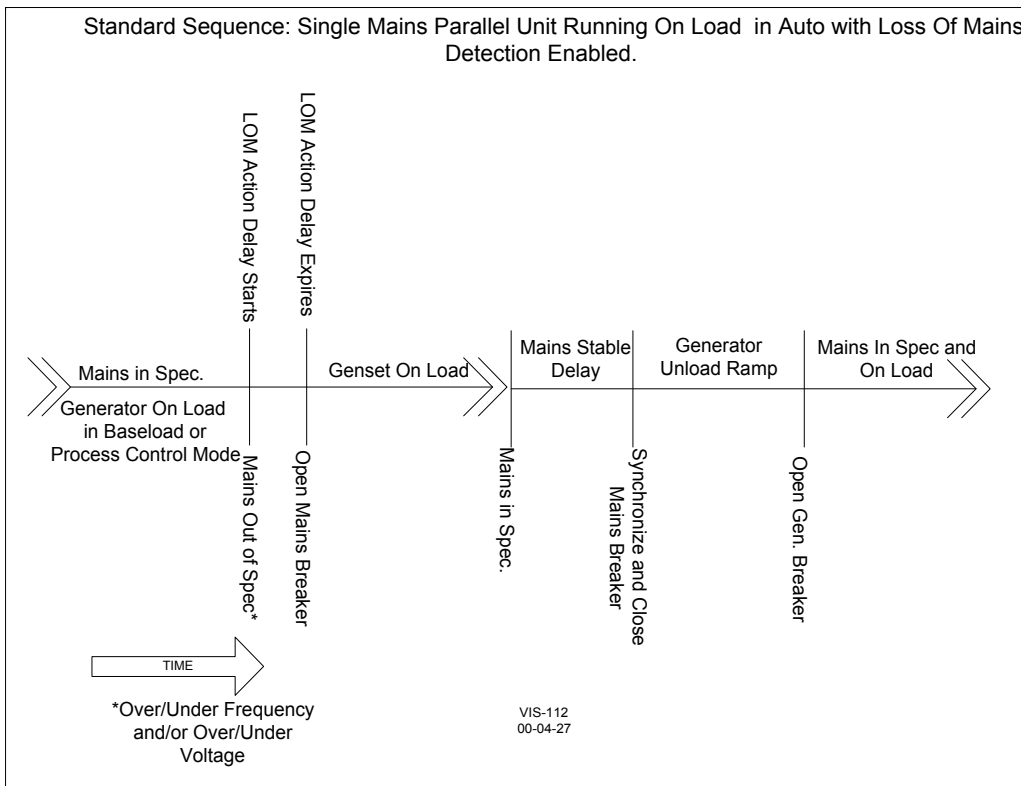

Figure 5-7. Mains Parallel Unit with Voltage/Frequency Detect

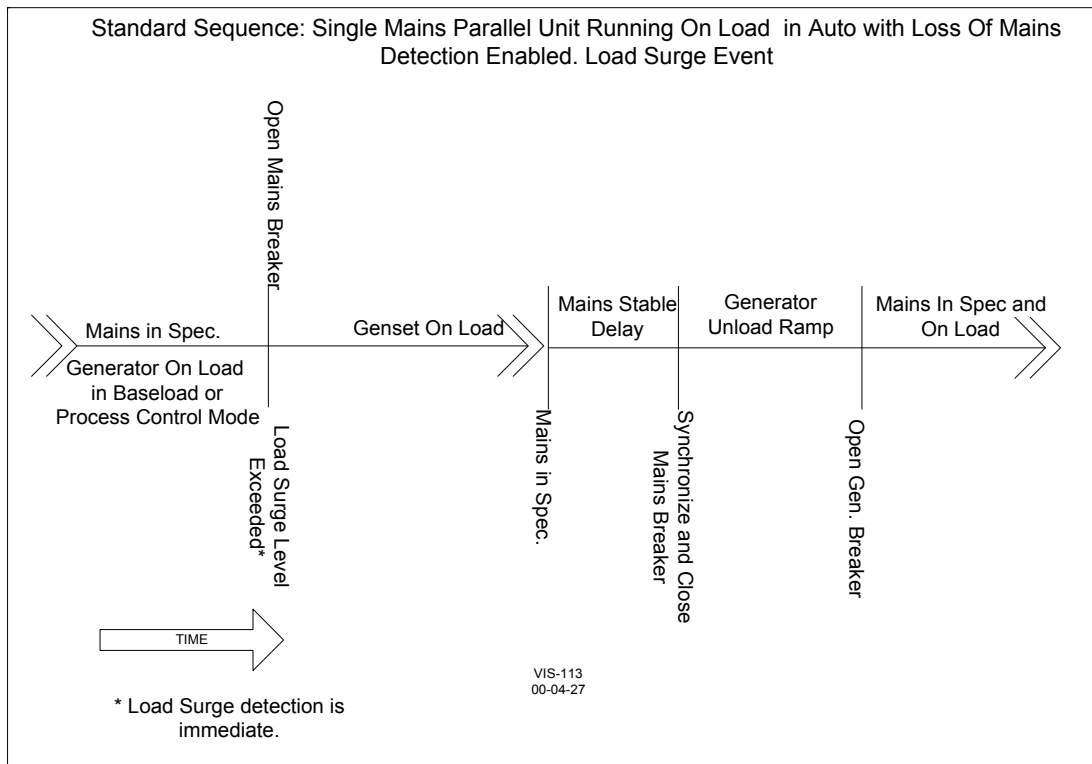

Figure 5-8. Mains Parallel Unit(s) with Load Surge Detect

Generator Sequencing

Generator Sequencing is a capability of the EGCP-2 control to maintain an on-line generator capacity to Kilowatt load ratio for a multiple unit setup. In order to activate the automatic sequencing function of the EGCP-2, each unit in a multiple unit system must have the following software set points enabled:

Configuration Menu:

| | |
|-----------------|----------------------|
| Number of Units | Automatic Sequencing |
| Multiple | Enabled |

Each unit in the system must be in the Auto mode (Discrete Input #1 Closed) to be an active part of the sequencing system.

When configured for automatic sequencing, as described above, the Sequencing status screen of the EGCP-2 will show all of the active units on the network in order of their Network Address, and the priority of those units in the sequencing scheme. Units not in Auto mode, or with the Number of Units set point set for Single, will display the message “Manual Unit No Sequencing” in the Sequencing Status Screen. Units in Auto mode, and set for Multiple unit operation, but with the Auto Sequencing set point Disabled will still appear in the Sequencing status screen, but will not respond to automatic sequencing commands from the Master, and are not capable of operating in a Master control mode.

Auto Sequence Delay

The Auto Sequence Delay timer starts when the Master unit closes its generator breaker. This will delay the Master unit from sequencing off slave units until this timer has expired. Sequencing can be delayed for 20 minutes, allowing the system load to stabilize.

The EGCP-2 uses calculated system load levels to determine the points at which the master sequences on or off units. The master may not sequence a unit off load, even though it is at or below the min gen load set point, if this would cause the system load to rise above the Max Gen Load minus 10%.

A typical automatic sequencing scenario is shown below. The system represented is composed of three units on an isolated bus feeding varying plant loads that are fed by the generators. The master unit (network priority #1) has the following set points for sequencing in the Sequencing and Comms menu:

| | |
|------------------------------|--------------------------------|
| Max Gen Load = 65% | Next Genset Delay = 30 seconds |
| Rated Load Delay = 5 seconds | Max Start Time = 60 seconds |
| Min Gen Load = 25% | Reduced Gen Dly. = 30 seconds |
| Max Stop Time = 15 seconds | |

IMPORTANT

These settings are for demonstration only. Sequencing set points may vary depending upon system requirements.

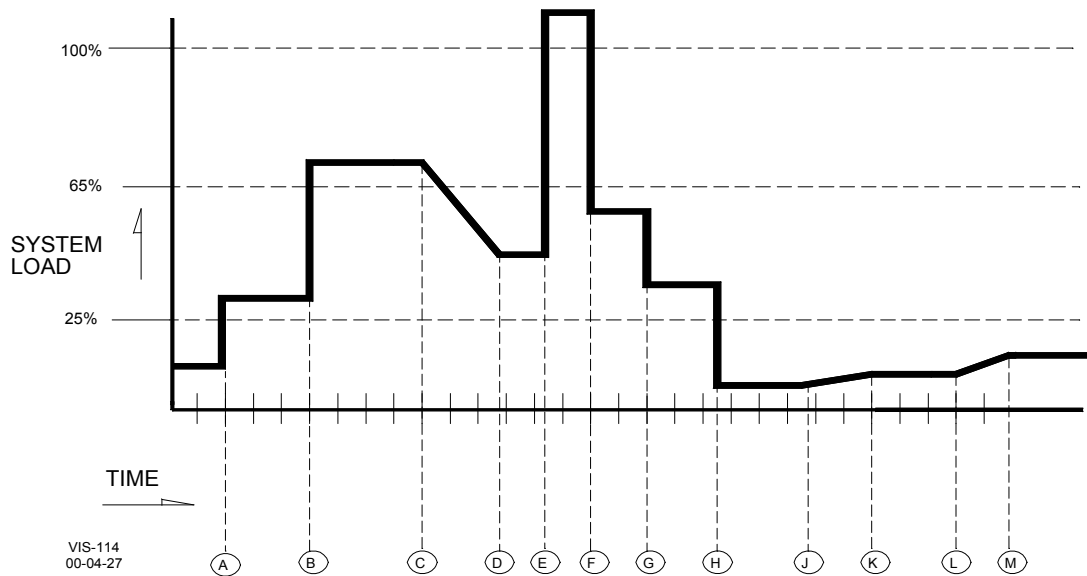

Figure 5-9. Typical Automatic Sequencing Scenario

Point A

Master Generator carrying load isochronously on an isolated bus. System load steps from approximately 10% to 30%.

Point B

Master Generator responds to a step load that brings the system load to approximately 70%. This level exceeds the Max. Gen Load set point (65%) in the Sequence and Comms tuning menu. The Master control begins timing for the Next Genset Delay period 30 seconds. After the 30 seconds expires, the load is still above the Max Gen Load set point. The master control issues a start command to the next unit on (network priority #2).

Next Genset Delay—Only on the Master controls Sequence Status screen, to the right of this item, you can see the delay time being counted down from 30. It will keep repeating this countdown and continue starting units until the system load level goes below the Max Gen Load set point.

Point C

Ten seconds after receiving its start command, network priority #2 unit closes onto the bus and ramps into load sharing with the master.

Point D

System load levels drop to approximately 45% after unit #2 is finished ramping into load sharing.

Point E

A very large step load on the bus loads both generators in excess of 100% of their rated load. The system load reflects these levels. The master unit begins timing to the Rated Load Delay (5 seconds) before starting the third unit.

Point F

The third unit closes its breaker to the two units already on the isolated bus. Since the rated load delay is in effect, and the system load is above 100% of the generating capacity on line, the third unit immediately goes to load sharing, without any load ramping. System load drops immediately to approximately 55% when the third unit closes its breaker to the bus.

Point G

A step load decrease on the bus brings the system load down to approximately 35%. All three generators remain on line in isochronous load sharing.

Point H

A further step load decrease on the isolated bus brings the system load below the Min Gen Load set point of 25% to approximately 10%. The master begins timing for the Reduced Gen Dly time of 30 seconds.

Reduced Load Dly—Only on the Master controls Sequence Status screen, to the right of this item, you can see the delay time being counted down from 30. It will keep repeating this countdown and continue to stop units until the system load level increases above the Min Gen Load set point or until all units have been sequenced off.

Point J

Since the system load is still below 25%, and the master's Reduced Gen Dly timer has expired. The master unit issues a command to Unit 3 (network priority 3) to off load and opens its gen breaker. Unit 3 begins to ramp off load. System load begins increasing. The master begins its Max Stop Time delay of 15 seconds before checking to see system load is low enough to allow sequencing of another unit off line.

Point K

Unit 3 reaches its unload trip point and opens its generator breaker. The system load is still below the Min Gen Load set point of 25%. The Master's Max Stop Time delay has expired. The master begins timing for the next gen off delay time.

Point L

The system load remains below 25%, and the master issues a command to unit #2 (network priority #2) to off load.

Point M

Unit 2 ramps off load and opens its generator breaker. This leaves the master unit (network priority #1) on line supplying the load. When required the master will sequence units on and off line as shown above and determined by the sequencing set points in its Sequencing and Comms menu.

The Master unit in any multiple unit EGCP-2 system is always the unit with the lowest Network Priority setting. All slave units are then sequenced on line in ascending order of their Network Priority settings, and sequenced off line in descending order of their Network Priority Settings. The Master is always responsible for any automatic sequencing of the slave units on and off line.

When the application consist of multiple units of different sizes, the sequencing of units offline changes. The Master cannot look only at the System Load level to determine when to sequence off a unit. The Master also knows the kW load the slave unit is carrying. This allows the Master to determine when it can unload a unit without increasing its load over the Max Gen Load level.

Example:

| | |
|----------------------|-----------------------|
| Generator 1 = 500 kW | Generator 2 = 1000 kW |
| Master | Slave |
| Max Gen Load = 60% | |
| Min Gen Load = 25% | |

Isolated bus, both units are online.

System Load = 50% No Change

System Load = 25% No Change

There is no change because 25% means

500 kW has 125 kW of load

1000 kW has 250 kW of load

- If the Master unit sequenced off the 1000 kW generator, the 500 kW would be carrying 375 kW, System Load = 75%
- The Master cannot sequence off Generator 2 until the System Load will be 50% or less after generator 2 is offline.
- What is 50% load to Generator 1? System Load = 50% = 250 kW
- So the total system load must be 250 kW or less before generator 2 can be sequenced off. This is a System Load of 16% or less with both generators operating.

Network Priority

In order to give the end user of the EGCP-2 the ability to control engine run time levels in a multiple unit system, any EGCP-2 in the system can be used to change the network priority of any of the EGCP-2 units actively on the same network. For a unit to be active on the network, it must have its Auto discrete input closed, be configured for Multiple Unit operation, have its Auto Sequencing set point Enabled, and be physically connected to the RS-485 network between units.

The ability to change the priority of any unit on the network has some fundamental rules associated with making changes to the unit priority.

These rules have to do with assuming a new master, changing the sequence of on load units, and permissive sequence change states.

Here are some reasons the Master will NOT pass to another unit:

1. If the System Load is greater than the Max Gen Load level of the Master.
2. Auto Sequencing = Disabled
3. EGCP-2s operating in the Base Load mode

Assuming a New Master—All Units Off Load

When a unit's priority is changed in such a manner as to make it the new master on the system, the response of the system to the change of masters depends on the operating state of the system at the time the change is made.

If the system is not on load and the engines are not running, and has not experienced, or is not configured for a loss of mains condition, then switching the priority of the master will have the following effect on the system:

After a maximum of **5 seconds**, the Master indication in the Sequencing Status screen will indicate the new master unit.

Shortly after this occurs, the new Master's Sequencing Status screen will re-order the Next On and Next Off slave units to fit the new system priority configuration.

No units will start or go on load under these conditions as a result of the assumption of the new master.

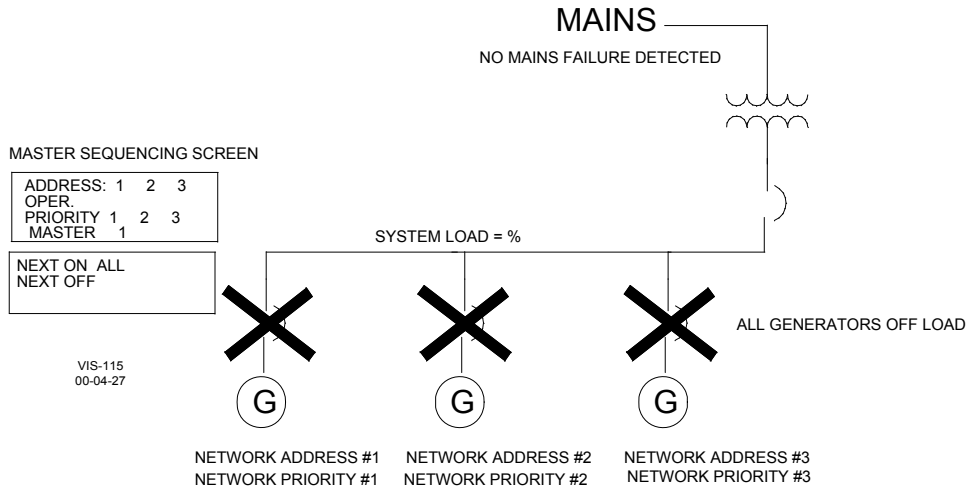

Figure 5-10. Original System Configuration

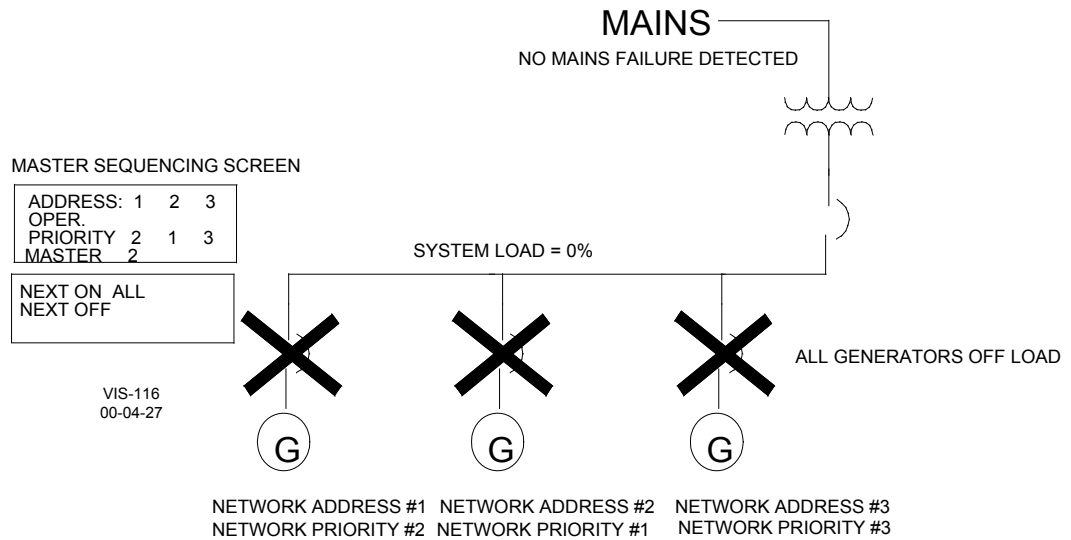

Figure 5-11. After a Change of Priority—Units Not Operating

Assuming a New Master—Master On Load

The next sequencing priority change scenario involves having the master unit on the isolated bus due to a loss of mains condition. The two slave units are off line because the system load does not require them to be sequenced on line. Changing the network priority of the master will establish a new master on the system.

The master unit will have a **Min Gen Load setting of 25%**, and a **Max Gen Load setting of 65%**. These values will be used throughout the remaining examples.

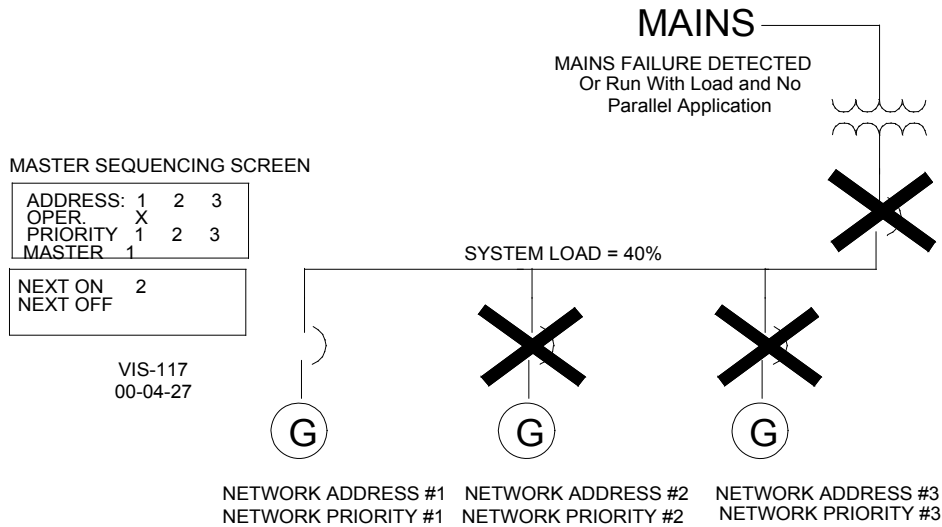

Figure 5-12. Original System Configuration

Within a **1-minute** period the sequencing screen on any unit will reflect the change of master from unit one to unit two.

The system load is at a level somewhere between 25 and 65 percent, at which no slave units are sequenced on or off line.

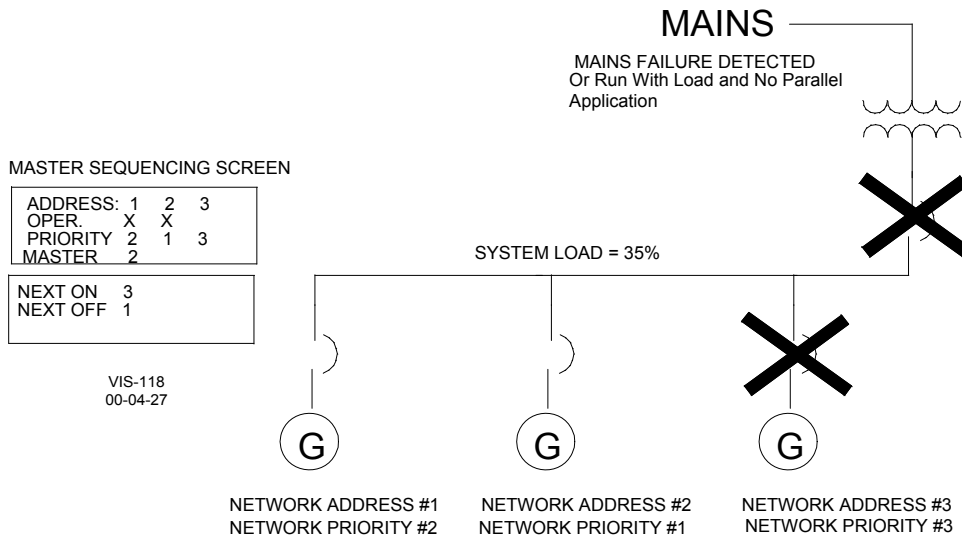

Figure 5-13. Master transfers to Unit 2

When the sequencing screen displays the new master, the new master engine will begin its start sequence. The new master must start and go on line in order to take over its new role as master, which means to be in control of the load, and of the sequencing control of the slave units.

Remember: The new Master needs a reason to start. If the original Master was started with a Run w/Load input and you switch the Master to another unit that only has the AUTO input closed, the new Master will NOT start. This example shows that the new Master will start due to a LOMs condition.

If all 3 units are in the AUTO mode, and a LOMs is detected. All 3 units will be told to start by the Master. Once online the Master could sequence the slave units off if the system load was low. Now if I switch Masters, the new Master will start and synchronize on to the bus. The new Master will now follow its sequencing values for starting and stopping the slaves.

The new master (Network Address 2) will start and parallel to the previous master (Network Address 1). Load control will be isochronous load sharing between the two units. See Figure 5-13. If the system load is greater than 25%, then both units will remain on line. If the system load drops below 25%, then the new master (Network Address 2) will sequence the slave (Network Address 1) off line.

The new master has fully established itself on the network as the Master.

The above actions take place simply by changing the priority of any given unit so that that unit is the New Master. As long as the unit is in auto mode, configured for multiple unit operation and attached to the network, it will automatically transfer itself to the Master Position.

Units operating in Auto with the Run with Load discrete input closed will effectively transfer, or recognize the transfer of master units. However, being in an auto and run with load mode, those particular units cannot be sequenced off line by the master control.

If a unit is not in auto mode, or is configured for single unit operation, or is not attached to the RS-485 network, then no transfer of master can occur.

Also, for a transfer of master to occur, the units have to be in an auto sequencing mode of operation. This implies either a load sharing or process mode of load control. Without being in these operating modes, a transfer of master cannot occur because the New Master cannot sequence the Previous master off line. The load control mode, which does not support master transition, is the Base Load mode. In Base Load Mode, there is no sequencing between units, and therefore a change of master cannot take place until the units are either taken out of base load mode, or switched to an isochronous load sharing, or process control mode.

IMPORTANT

Master Controls operating in the Process Control Mode must have a 4–20 mA or 1–5 Vdc transducer input to function properly.

Changing the Priority of a Slave Unit—No Slaves On Load

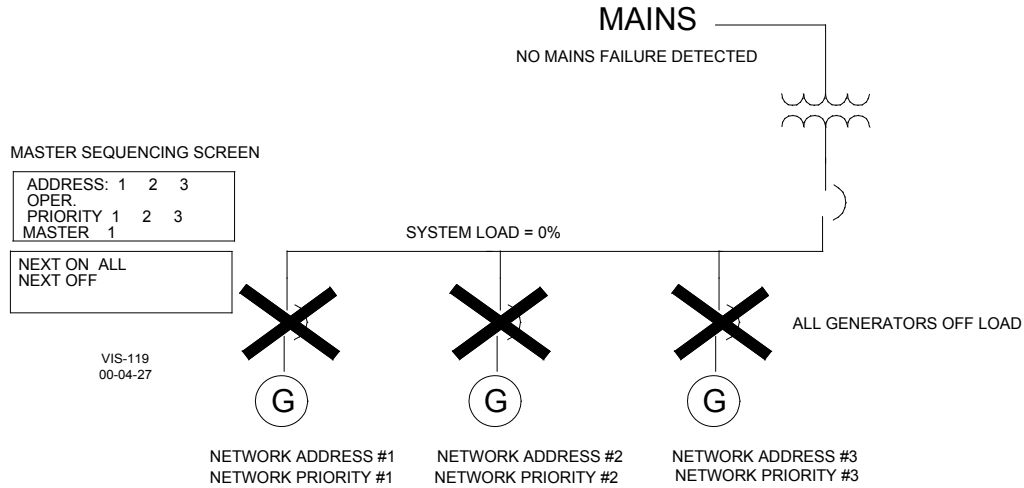

Figure 5-14. Changing the Priority of a Slave Unit

If a slave unit's priority is changed in such a way as to simply shift that slave's place in the sequencing scheme without making the slave a New Master, then one of two things will happen depending on that slave's place in the priority order:

1. The slave will simply take its place in the new sequencing order without having to go on load.
2. The slave will have to go on load in order to properly assume its new priority setting in sequencing system.

Case 1 will occur if the slave's priority is changed either when there are no units running, and no Loss of Mains detection has occurred, or if the slave itself is not running due to system load levels not requiring the unit to be on line, and the priority of the slave is decreased (taken to a higher numerical value).

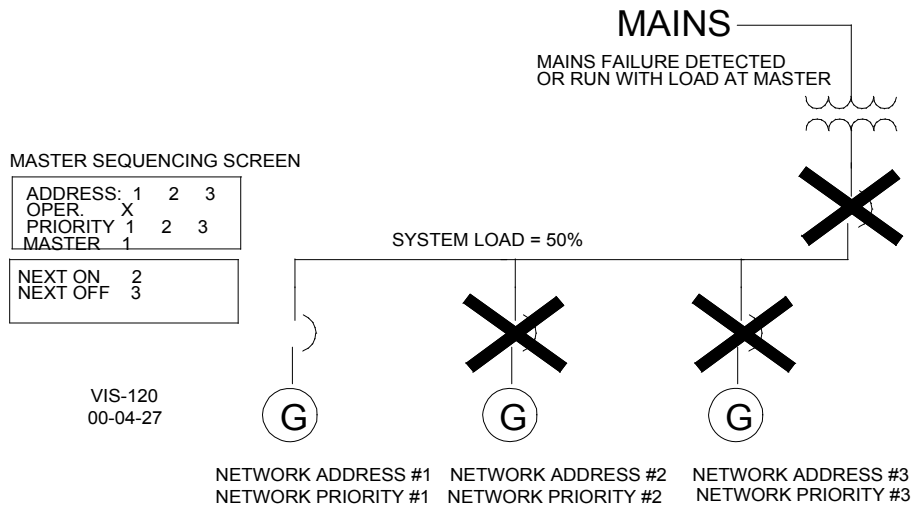

Figure 5-15. Changing the Priority of a Slave Unit

Master running on load against the isolated bus (Figure 5-15). System load level is at 40%, so no slave units are sequenced on line.

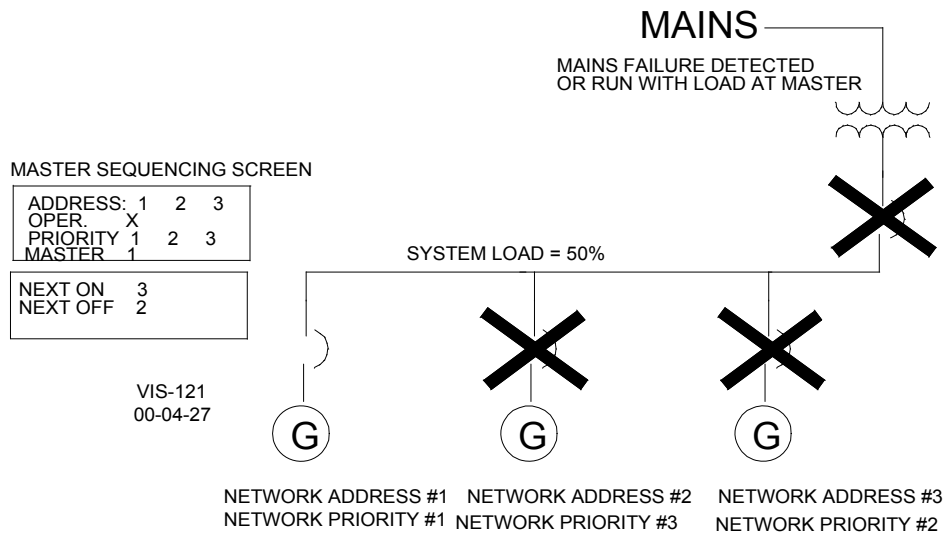

Figure 5-16. Changing the Priority of a Slave Unit

A priority change at units with the network addresses of #2 and #3 switches the network priority between these two units. Since neither unit is operating (only the master is on load) the priority change takes place, and is recognized by the master. The change is seen in the next on /next off display at the master sequencing status screen. See Figure 5-16.

Changing the Priority of a Slave Unit—Slave On Load

Case 2 will occur if the slave unit is not running, and no Loss of Mains detection has occurred, and the slave’s priority is increased (taken to a lower numerical value) to a level that replaces another slave, which is operating on load.

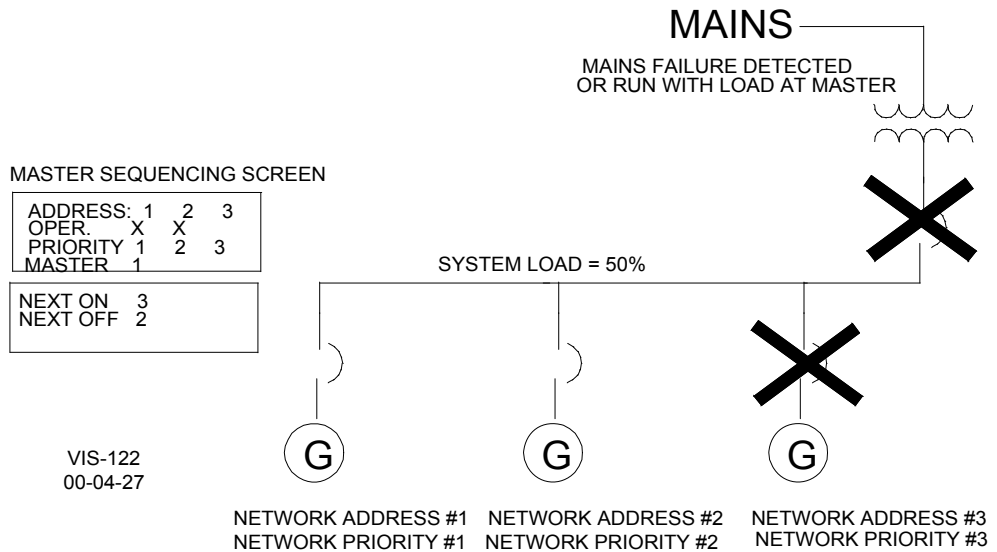

Figure 5-17. Changing the Priority of a Slave Unit

Above figure represents system on load on an isolated bus in load sharing. The master unit has sequenced on the priority 2 slave unit. System load is at 50%.

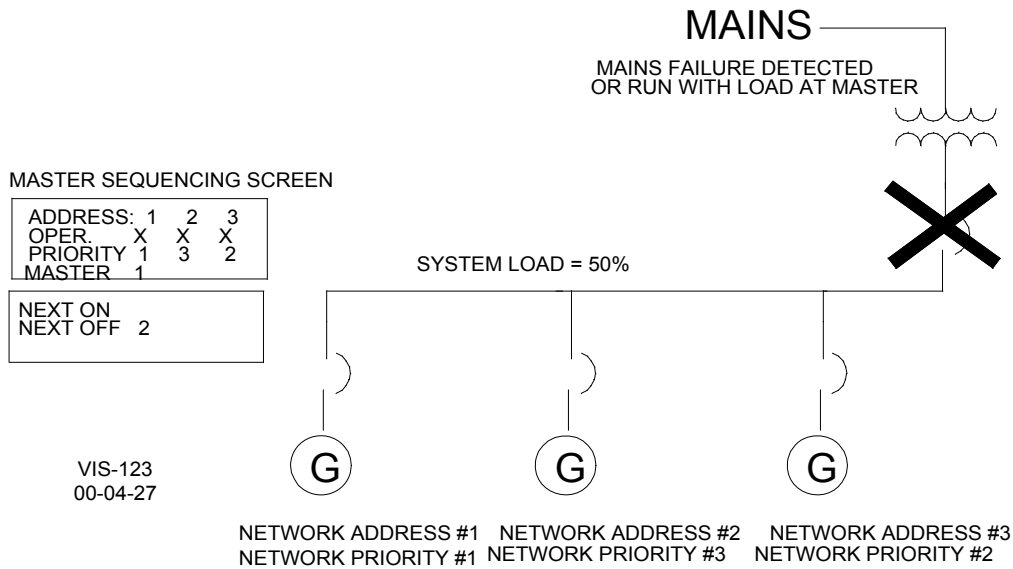

Figure 5-18. Changing the Priority of a Slave Unit

The network priority of the priority 2 and 3 units are switched so now the unit with network address #3 is priority 2, and network address #2 is priority 3. After a time delay of less than 5 minutes, the #3 network address (priority 2) unit is started by the master and paralleled to the bus. Now all three units are on line. See Figure 5-18. The master recognizes the proper on/off sequence for the new priority settings, and will sequence off network address #2 unit when system load levels fall below 25%. See Figure 5-19.

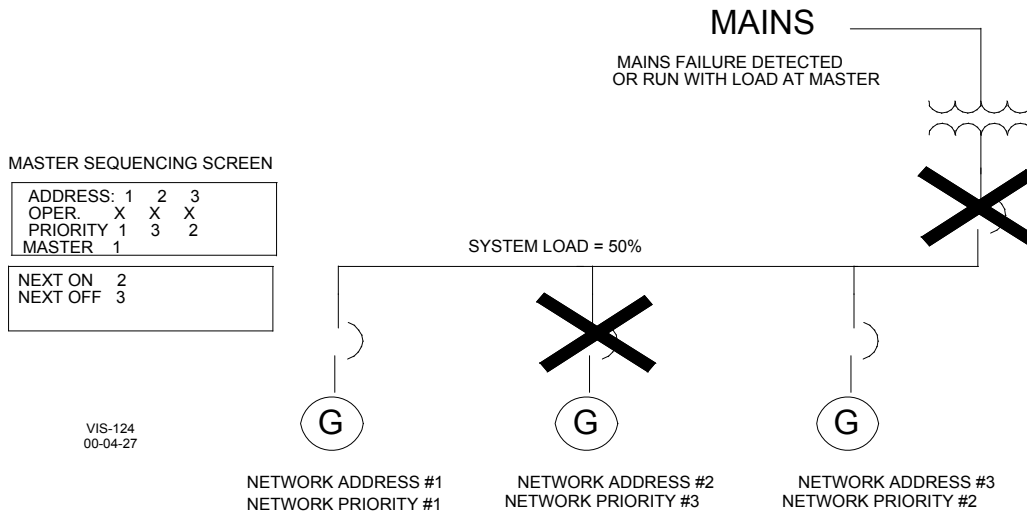

Figure 5-19. Changing the Priority of a Slave Unit

System load levels have dropped below 25%, and the master has sequenced network address #2, priority 3 unit off line. The master has fully recognized the priority change, and the new priority settings are in effect.

The above examples are typical sequencing functions of the EGCP-2. Isolated bus applications were shown for clarity. The EGCP-2 is capable of automatic sequencing while in parallel with the mains in the process control, or process control soft transfer operating modes. The examples shown above for priority changing and its effects are accurate in mains parallel multiple unit process control modes as well.

Chapter 6.

Calibration of Control Inputs and Outputs

Introduction

The EGCP-2 can be thought of as a digital metering device that monitors engine, generator, bus, and mains analog signals. Being a digital metering device, the EGCP-2 must be properly calibrated in order to perform its role as a controlling device accurately. This chapter discusses the calibration of these various inputs and outputs of the EGCP-2, and the effects of the calibration on the metering and control functions of the EGCP-2.

The EGCP-2 inputs and outputs are factory calibrated for the best possible tolerance between the input signal, and the signal as sensed by the EGCP-2. All analog signals coming into the EGCP-2 are routed through analog to digital (A/D) converters. These converters have the ability to be “calibrated” so that the input signals sensed by the EGCP-2 software are equal to the true input signal.

While the factory calibration brings the EGCP-2 control within close tolerance of the various inputs as fed into the control, it cannot account for losses in field wiring that are common in power generation applications. Signal loss due to wire length and impedance, transformer primary to secondary losses, and non-linearity of sending devices cannot be calibrated out at the factory. This is why the EGCP-2 must be calibrated upon commissioning.

The intent of calibrating the EGCP-2 is to make the unit read out the various voltages, currents, frequencies, and temperatures in the various status menu display screens as close as possible to what is actually occurring at the true source of these signals.

For example, assume there is a 480 volt line-to-line generator set operating in a system that uses 4:1 voltage transformers to feed the EGCP-2. The input AC line to line voltage at the EGCP-2 is 118 volts due to primary to secondary losses across the voltage transformers. The EGCP-2 Generator Status menu will display a generator voltage of 472 Vac L-L for each phase, which is not truly what the generator is producing. In this case, the Calibration tuning menu would be used to adjust the A/D converters on the three generator voltage transformer inputs until the Generator Status menu reads 480 Vac L-L for each phase. This is how the calibration menu is used to compensate for losses in signal between the source, and the EGCP-2. The calibration menu allows adjustment of all the analog inputs and outputs of the EGCP-2.

Calibration of Generator PTs and CTs

The Calibration menu of the EGCP-2 contains calibration adjustments for three phase generator voltage and current. These calibration adjustments are labeled as follows:

PT Phase A Scale

Calibrates the A phase generator PT input.

Menus Affected

Changes in the calibration set point will change the generator A phase voltage as seen on the Generator Status screen. Changing this value will also have an effect on generator kW and kVAR levels.

The generator A phase voltage is also used as part of the function that determines when the generator is stable as shown in the System Status menu by a ++ following the GEN label. If the generator A phase PT is not properly calibrated, the level at which the generator is shown as stable may not be a true indication of a stable condition.

Operations Affected

The EGCP-2 uses the A phase generator voltage for voltage matching when synchronizing across the generator breaker. Accurate calibration of the Generator A phase PT is critical for proper voltage matching operation.

The sensed generator voltage on the A phase is used in Power Factor/VAR sharing mode when the EGCP-2 is in parallel with other units on an isolated bus. The EGCP-2 uses the Voltage Reference as found in the Configuration tuning menu as a generator voltage reference point when balancing the reactive load on the bus between generators. If the A phase PT voltage is out of calibration at the EGCP-2 the bus voltage may be off of this reference when in Power Factor/VAR sharing mode. Also, poor VAR/PF sharing may occur if the A phase PT is not properly calibrated.

Generator Voltage is also used in real and reactive load calculations. These calculations are used in all real and reactive power control functions.

Alarms Affected

The PT Phase A voltage is used for the Voltage High and Low limit set points that are found in the Shutdown and Alarm tuning menu. The voltage limit set points can be configured for various alarm indications. Also, if the generator voltage as sensed by the EGCP-2 exceeds the Voltage High limit, or falls below the Voltage Low limit, the voltage bias output will stop moving in the direction that the alarm occurred.

The A phase PT voltage is used in the calculations for kW and kVAR load. All alarms monitoring these conditions will be affected if the A phase PT is not properly calibrated.

PT Phase B Scale

Calibrates the B phase generator PT input.

Menus Affected

Changes in the calibration set point will change the generator B phase voltage as read in the Generator Status screen. Changing this value will also have an effect on generator kW and kVAR levels.

Operations Affected

Generator Voltage is used in real and reactive load calculations. These calculations are used in all real and reactive power control functions.

Alarms Affected

The B phase PT voltage is used in the calculations for kW and kVAR load. All alarms monitoring these conditions will be affected if the B phase PT is not properly calibrated.

PT Phase C Scale

Calibrates the C phase generator PT input.

Menus Affected

Changes in the calibration set point will change the generator C phase voltage as read in the Generator Status screen. Changing this value will also have an effect on generator kW and kVAR levels.

Operations Affected

Generator Voltage is used in real and reactive load calculations. These calculations are used in all real and reactive power control functions.

Alarms Affected

The C phase PT voltage is used in the calculations for kW and kVAR load. All alarms monitoring these conditions will be affected if the A phase PT is not properly calibrated.

CT Phase A Offset

Calibrates the A phase generator CT input offset (zero current) reading.

Menus Affected

Changes in the calibration value will change the A phase current readout in the Generator Status screen. Changing this value will also have an effect on the generator kVA, kW, and kVAR levels.

Operations Affected

Generator Current is used in real and reactive load calculations. These calculations are used in all real and reactive power control functions.

Alarms Affected

The generator current on A phase is monitored and used as an input for the Overcurrent alarm. The EGCP-2 uses all three phase CT inputs for sensing overcurrent conditions, and selects the phase with the highest current at any given moment. Improperly calibrated A phase CT levels will affect the point of Overcurrent detection on the generator.

The A Phase CT calibration has an effect on kW and kVAR levels for the A phase, and for the sum of all three phases of the generator. The various alarm set points that monitor real and reactive load levels are affected by this calibration point.

CT Phase A Scale

Calibrates the A phase generator CT input.

Menus Affected

Changes in the calibration value will change the A phase current readout in both the Generator Status screen. Changing this value will also have an effect on the generator kW and kVAR levels.

Operations Affected

Generator Current is used in real and reactive load calculations. These calculations are used in all real and reactive power control functions.

Alarms Affected

The generator current on A phase is monitored and used as an input for the Overcurrent alarm. The EGCP-2 uses all three phase CT inputs for sensing overcurrent conditions, and selects the phase with the highest current at any given moment. Improperly calibrated A phase CT levels will affect the point of Overcurrent detection on the generator.

The A Phase CT calibration has an effect on kW and kVAR levels for the A phase, and for the sum of all three phases of the generator. The various alarm set points that monitor real and reactive load levels are affected by this calibration point.

CT Phase B Offset

Calibrates the B phase generator CT input offset (zero current) reading.

Menus Affected

Changes in the calibration value will change the B phase current readout in the Generator Status screen. Changing this value will also have an effect on the generator kVA, kW, and kVAR levels.

Operations Affected

Generator Current is used in real and reactive load calculations. These calculations are used in all real and reactive power control functions.

Alarms Affected

The generator current on A phase is monitored and used as an input for the Overcurrent alarm. The EGCP-2 uses all three phase CT inputs for sensing overcurrent conditions, and selects the phase with the highest current at any given moment. Improperly calibrated B phase CT levels will affect the point of Overcurrent detection on the generator.

The A Phase CT calibration has an effect on kW and kVAR levels for the B phase, and for the sum of all three phases of the generator. The various alarm set points that monitor real and reactive load levels are affected by this calibration point.

CT Phase B Scale

Calibrates the B phase generator CT input.

Menus Affected

Changes in the calibration value will change the B phase current readout in both the Generator Status screen. Changing this value will also have an effect on the generator kW and kVAR levels.

Alarms Affected

The generator current on B phase is monitored and used as an input for the Overcurrent alarm. The EGCP-2 uses all three phase CT inputs for sensing overcurrent conditions, and selects the phase with the highest current at any given moment. Improperly calibrated B phase CT levels will affect the point of Overcurrent detection on the generator.

The B Phase CT calibration has an effect on kW and kVAR levels for the B phase, and for the sum of all three phases of the generator. The various alarm set points that monitor real and reactive load levels are affected by this calibration point.

CT Phase C Offset

Calibrates the C phase generator CT input offset (zero current) reading.

Menus Affected

Changes in the calibration value will change the C phase current readout in the Generator Status screen. Changing this value will also have an effect on the generator kVA, kW, and kVAR levels.

Operations Affected

Generator Current is used in real and reactive load calculations. These calculations are used in all real and reactive power control functions.

Alarms Affected

The generator current on C phase is monitored and used as an input for the Overcurrent alarm. The EGCP-2 uses all three phase CT inputs for sensing overcurrent conditions, and selects the phase with the highest current at any given moment. Improperly calibrated A phase CT levels will affect the point of Overcurrent detection on the generator.

The A Phase CT calibration has an effect on kW and kVAR levels for the C phase, and for the sum of all three phases of the generator. This calibration point affects the various alarm set points that monitor real and reactive load levels.

CT Phase C Scale

Calibrates the C phase generator CT input.

Menus Affected

Changes in the calibration value will change the C phase current readout in both the Generator Status screen. Changing this value will also have an effect on the generator kW and kVAR levels.

Alarms Affected

The generator current on C phase is monitored and used as an input for the Overcurrent alarm. The EGCP-2 uses all three-phase CT inputs for sensing overcurrent conditions, and selects the phase with the highest current at any given moment. Improperly calibrated C phase CT levels will affect the point of Overcurrent detection on the generator.

The C Phase CT calibration has an effect on kW and kVAR levels for the B phase, and for the sum of all three phases of the generator. This calibration point affects the various alarm set points that monitor real and reactive load levels.

Calibration of the Bus PT

The bus PT input to the EGCP-2 plays a “dual role” in that it is used to sense both the bus, and the mains PT voltage sensing. The EGCP-2 automatically switches between the Bus and the Mains PT input when performing mains monitoring, synchronizing and dead bus closing actions.

Bus PT Scale

Calibrates the Bus and Mains Voltage readouts on the EGCP-2.

Menus Affected**Mains Voltage Sensing**

The Bus PT input is used as part of the sensing, which determines when the mains voltage is within spec as shown in the System Status Screen by two plus symbols (++) following the MAINS label. The Synchroscope Status screen will monitor the Mains voltage in every synch mode except “Close Gen Bkr”. In the “Close Gen Bkr” mode it monitors the Bus voltage.

Bus Voltage Sensing

The Bus PT input is used when synchronizing across the generator breaker to the bus (live or dead bus closing). The Synchroscope status screen will display the Bus voltage at the “Mains VL-L:” value when performing Close Gen Breaker Functions.

Operations Affected

The Bus PT Scale calibration will affect the Voltage matching accuracy when the generator is paralleling to other generators on the isolated bus (Bus PT monitored), or when the generator is paralleling to the mains (Mains PT monitored). Improper calibration of the Bus PT sensing of the EGCP-2 may cause large reactive load swings when paralleling into the bus or mains when the generator breaker closes.

Alarms Affected

The Bus PT scale calibration will affect the Mains High and Low Voltage Limit alarm set points in the Shutdown and Alarms tuning menu. If the Bus PT scale is improperly calibrated, the sensed voltage for these high and low alarm set points may cause alarms and/or loss of mains action to occur at the wrong voltage levels.

Speed Bias Output

The Speed Bias Offset calibration point sets an offset on the speed bias output of the EGCP-2. This output is fed into the speed control governor to bias the governing speed for synchronization and load control functions. This offset is the starting point from which the EGCP-2 begins all of its speed biasing operations. Factory calibrated for:

| Speed Bias Type | Voltage at Terminals 73(+) – 74(-) | Speed Bias Offset |
|-----------------|---------------------------------------|-------------------|
| ±3 Vdc | 0.00 Vdc | 0.0% |
| 0.5 – 4.5 Vdc | 2.5 Vdc | 0.0% |
| PWM | 50% Duty Cycle | 0.0% |

The Speed Bias will be calibrated to have the generator set operating at 50.0 or 60.0 hertz.

```
Speed Bias Offset
-0.42 %
-----CALIBRATION-----
Hz: 60.0
```

Calibration is required for Caterpillars ADEM speed control. PWM range needs to be calibrated for 69% Duty Cycle as measured on Terminals 73(+) and 74(-).

Preset Speed Bias Offset to 39.00%

```
Speed Bias Offset
39.00 %
-----CALIBRATION-----
Hz: 0.0
```

Start Engine

Adjust Speed Bias Offset for rated speed of 50 or 60 Hertz.

Press the Enter key to save the final setting

Increasing the Speed Bias Offset will increase the Speed Bias readout in the I/O Display status screen of the EGCP-2. The speed bias offset imposes an offset in percent of speed bias output. For example a Speed Bias offset of 3% will give a 3% speed bias reading in the I/O Display status screen. Decreasing the Speed Bias Offset has just the opposite effect in that the values will read negative instead of positive.

Voltage Bias Output

The Voltage Bias Offset in the Calibration menu is used to impose an offset voltage on the voltage bias output to the automatic voltage regulator. This dc voltage offset is applied to the voltage bias input of the automatic voltage regulator, and is maintained as a starting point for all voltage bias operations used by the EGCP-2.

Chapter 7.

General Start-up Instructions

Before Starting the Generator Set

Before starting the generator set, configure the tuning set points in the EGCP-2 for values which best match the machines operating and performance characteristics. Double-check these values prior to starting the unit.

Verify Proper wiring to the EGCP-2. Check the following items for proper polarity and configuration:

- Power Supply Input
- Generator CT Inputs
- Generator PT Inputs
- Mains and Bus PT Inputs
- Magnetic Pickup Input
- Voltage Bias Output
- Speed Bias Output

Once these items have been checked for proper polarity, check the power supply voltage for proper amplitude. When this is confirmed, apply the power supply to the EGCP-2.

With the EGCP-2 powered up, the unit will go through a RAM test, and after a self check period, will display the System Status Screen. If the control fails to power up properly, remove the power supply input and re-check the polarity and amplitude of the voltage feeding the EGCP-2 Control.

With the EGCP-2 powered, go to the I/O Status Display in the Status screens. This display shows the state of the various discrete inputs and outputs of the control. Monitor this screen and close the discrete inputs to the EGCP-2 that are being used in this particular application. Verify that the EGCP-2 recognizes these inputs in the I/O Status screen.

Verify that the Speed Bias and Voltage Bias outputs are at the proper levels for the devices being used.



Make sure that a means exist of performing an emergency stop prior to starting the unit. Check the emergency stop devices to make sure they are functioning properly prior to starting the unit.

Sequence of Start-up and Checking Parameters

1. Enter program set points in all menus.
2. Check discrete inputs in I/O status menu.
3. Set crank repeats to 0.
4. Set synchronizer mode to check.
5. Set load control mode to normal.
6. Start engine using test switch (discrete input 2) of EGCP-2.
7. Check Engine Status screen for engine rpm readout confirm rpm is correct for unit.
8. Check voltage of unit in Generator Status screen—calibrate voltage if needed.
9. Adjust AVR voltage at AVR if needed to achieve rated generator voltage.
10. Follow AVR connection and setup procedure in Appendix C.
11. Check that voltage raise/lower switches (discrete inputs 4 and 5) operate properly.
 - Set voltage ramp time if needed.
12. Check that load raise/lower switches (discrete inputs 6 and 7) operate properly.
 - Set load raise/lower rates if needed.
 - Verify speed change with raise/lower load inputs.
13. Check mains voltage in synchroscope status menu (if available)—calibrate if needed.
14. Remove Test Input. Verify engine shuts down properly.

Loading the Generator Set



Operation of the engine/generator set with incorrect CT and PT phasing could cause serious injury or damage to equipment. If the load on the unit rises rapidly when the generator or mains breaker is closed, immediately open the breaker and shut the unit down. Check the phasing of the PT and CTs. DO NOT permit the unit to continue to pick up load or operate the system without correcting this condition.

Mains Parallel Units

Follow these steps if you are configuring a Mains Parallel Master Unit, or a Mains Parallel Slave unit, which will operate as a redundant master. Redundant master units must have the Mains CB Aux hardwired into them. All other wiring to the Master and Redundant Master Units must be identical for proper operation of the redundant units in the event of a loss of master.

1. Set load/unload ramp times to at least 60 seconds.
2. Set base load level to 30% of rated load.
3. Start unit with an Auto and Run with Load Input.
 - a. Unit will start and attempt to synchronize.
4. Adjust synchronizer dynamics for best control of phase matching (monitor synchroscope status menu to see phase error.).
5. Use voltmeter to check voltage across generator breaker to assure proper phase rotation and mains PT input polarity.
6. Shut down the unit by removing the Auto and Run with Load Inputs.
7. Set synchronizer to run mode.
8. Start unit with an Auto and Run with Load Input.

9. Monitor synchroscope status menu.
 - a. Verify action of synchronizer.

IMPORTANT

If using Process 4–20 mA input, set Process Reference to proper level.

10. After generator breaker closes to the mains, monitor Generator Status screen.
 - a. Monitor kW load on unit.
 - b. Monitor kVAR/PF on unit.
 1. As set by reactive load control setting.
11. Adjust load control gain, stability, and derivative for stable load control.
12. Once satisfied with load control operation, switch to process control (if applicable).
13. Confirm ramp to process reference level.
 - a. Tune process control for best response.
14. Remove run with load input to unit.
 - a. Verify unload ramping.
 - b. Verify unload trip point.
 - c. Verify generator breaker opens.
 - d. Verify cooldown timer (if reached).
15. Set crank repeats, base load reference, process reference, load ramp times, and load control mode as required for proper operation.

This concludes the Mains Parallel Master Setup.

No Parallel and Slave Setup

Use the following instructions for setup of No Parallel Applications, and Slave unit applications.

1. Set unit for LOM on mains under frequency.
2. Set Check Mains Breaker = disabled.
3. Set Dead Bus Closing = enabled.
4. Remove mains PT and mains CB Aux input by opening mains breaker if necessary.
5. Start unit with auto switch input.
6. Unit will start and close generator breaker to bus.
 - a. Verify dead bus closing.
 - b. Apply load to unit using load bank or plant load as applies.
 - c. Calibrate CT readings if needed.
7. If in a multi unit system, repeat previous steps for all units. Set all units to be tested synchronizers to check mode prior to start.
8. The unit currently on the bus carrying the load will act as a synchronizing reference for the other units.
9. Verify voltage matching, phase relationships of additional units by monitoring the synchroscope status menu.
 - a. Verify voltage levels across generator breakers.
10. Tune individual synchronizer dynamics.
 - a. Calibrate synchronizer if needed.
11. Once satisfied with each synchronizers operation, shut down these units by removing the auto input.
12. Change synch mode settings to run on all units.
 - a. This will enable generator breaker closure to live bus.
13. Start one unit in auto and allow it to close to the dead bus.
 - a. Verify isochronous operation.
 - b. Verify correct voltage level on bus.

14. Start another unit and allow it to parallel to the live bus.
 - a. Confirm phase match and synchronizer action.
 - b. Verify generator breaker closure.
15. Load Control
 - a. Verify load sharing.
 - b. Verify VAR/PF sharing.
16. Start additional units and parallel to the bus in the same manner as previous units.
 - a. Load must be sufficient to prevent sequencing of lower priority units off line.
 - b. Confirm unit address and priority settings.
 - c. Adjust load control gain lower if unstable during ramp to load sharing.
 - d. Adjust load share gain if unstable in load share.
17. Remove units from isolated bus one at a time by opening the auto input.
 - a. Verify unload ramp.
 - b. Verify unload trip.
 - c. Verify cooldown if unit has exceeded cooldown limit.
18. When all units are off line, close mains breaker if applicable.
 - a. Set all units to auto for LOM detection.

This concludes the No Parallel setup.

Chapter 8. Troubleshooting

Control Hardware and I/O

| Problem | Probable Cause | Corrective Action |
|--|--|--|
| Unit does not power up | No input power supply | Check input power supply on terminals 1 and 2. This input must be 9 to 32 Vdc. |
| | Input power supply reversed | Ensure proper polarity of power supply to EGCP-2. |
| Unit powers up and then cycles on and off when cranking | Weak Engine Battery or Engine Battery voltage dropping below 6 Vdc on cranking | Charge Engine Battery, or Replace Engine Battery. |
| Discrete inputs don't show active in I/O STATUS screen when switches are activated | Faulty wiring of discrete input switches | Verify wiring of discrete input switches. |
| Displayed generator voltages are very small | Faulty wiring of generator Potential Transformers(PT's) | Verify wiring of generator Potential Transformers (PTs). |
| | Generator PT inputs are improperly calibrated | Calibrate the appropriate PT input channel(s). See section 1.10 Calibration of Control Inputs and Outputs. |
| I/O STATUS shows relay(s) is energized, but action(i.e. alarm) does not occur | Faulty wiring of relay output contacts | Verify wiring of relay output contacts. |
| Generator voltage fluctuates or is unstable at no load on generator | AVR dynamics are improperly set up | Tune the AVR dynamics for stable operation. See AVR manufacturer's instruction manual for more details. |
| Voltages or currents displayed by EGCP-2 are different than measured parameter | EGCP-2 PT inputs are inaccurately calibrated | Calibrate the appropriate PT input channel(s). See section 1.10 Calibration of Control Inputs and Outputs. |

Engine Control/Sensing Parameters

| Problem | Probable Cause | Corrective Action |
|--|---|--|
| Start command(i.e. test or run with load) does not start engine | Configuration menu has not been accepted or entered properly | Enter the configuration set points in the Configuration menu such that all "*" and "#" symbols are removed from the display. See section 1.3.4 Description of set points for more details. |
| | An active alarm condition exists | Commit or reset alarm condition(s). See section 1.3.2 Description of Screens. |
| | Relay output contacts are not properly connected to engine starter, fuel solenoid | Verify wiring of relay output contacts. |
| Starter motor stays engaged after engine starts | Crank cutout set point in Engine control menu is too large | Set CRANK CUTOUT set point to appropriate value. See description of set points. |
| | Inadequate MPU signal to EGCP-2 input | Verify MPU wiring, and that adequate MPU signal exists at input to EGCP-2 control. |
| Engine speed is unstable when unit is at no load | Speed control dynamics are improperly set up | Tune the speed control dynamics for stable operation. See speed control manufacturer's instruction manual for more details. |
| When crank command is issued, EGCP-2 loses power and conducts a reset and RAM test | Battery is too weak for the current demand of the starter motor | Install a higher capacity battery or a more efficient starter motor. |
| | Faulty wiring of power supply to the EGCP-2 control | Verify wiring of power supply to the EGCP-2 control. |

Synchronization

| Problem | Probable Cause | Corrective Action |
|--|---|---|
| Unit never adequately matches phase | Synchronizer Mode set point in synchroscope menu set to PERMISSIVE | Set synchronizer Mode to appropriate setting. See description of set points. |
| | Synchronizer dynamics in synchroscope menu are improperly set up | Tune synchronizer dynamics. See description of set points. |
| Synchronizer displays small phase difference, but measured phase difference is large | Generator A phase PT input is L-L and bus A phase PT input is L-N or vice versa | Verify that Generator A phase PT input bus A phase PT input are the same form (i.e. L-N or L-L). |
| | Bus and/or generator PT inputs are not A phase | Verify that Bus and generator PT inputs are A phase. |
| | synchronizer improperly calibrated | Calibrate synchronizer. See calibration of control inputs and outputs. |
| Synchronizer matches phase, but never closes breaker/contact | Synchronizer Mode set point in synchroscope menu is set to CHECK | Set synchronizer Mode to appropriate setting. See description of set points. |
| | Dwell time set point in synchroscope menu is too large | Reduce Dwell Time set point in synchroscope menu. See description of set points. |
| Synchronizer displays matched phase, but measured phase difference is ~180 degrees, or when breaker closes it crash parallels the set 180 degrees out of phase | Generator or bus PT is reversed polarity (faulty wiring) | Verify correct polarity of Generator and bus PT inputs. |
| Unit won't close to dead bus | Multiple unit system with DEADBUS CLOSING set point in configuration menu set to DISABLED | ENABLE DEADBUS CLOSING set point in configuration menu. See description of set points. |
| | Synchronizer set point is set to CHECK | Set synchronizer Mode to appropriate setting. See description of set points. |
| Synchronizer won't voltage match | VOLTAGE MATCHING set point in synchroscope menu is DISABLED | ENABLE the VOLTAGE MATCHING set point in synchroscope menu. See description of set points. |
| Synchronizer does not voltage match within spec. | Generator A phase PT and/or Bus A phase PT input(s) are inadequately calibrated | Calibrate the Generator A phase PT and Bus A phase PT inputs. See calibration of control inputs and outputs. |
| | Voltage matching tolerance set point in synchroscope menu is too large | Appropriately set the Voltage matching tolerance set point in synchroscope menu. See description of set points. |

Breaker Close/Open Control

| Problem | Probable Cause | Corrective Action |
|--|--|---|
| When generator set is in synchronization, the breaker never closes | Synchronizer set to CHECK | Set synchronizer Mode to appropriate setting. See description of set points. |
| | Faulty wiring causing the relay output to not make connection to the breaker | Verify wiring of the relay output contacts. |
| | Dwell time set point in the synchroscope menu is too long | Reduce Dwell time set point in the synchroscope menu. See description of set points. |
| Contactors closes for a brief moment and then opens | C B CONTROL set point in configuration menu is set for BREAKER | Appropriately set the C B CONTROL set point in configuration menu. See description of set points. |
| | C B HOLD TIME set point in synchroscope menu is too short | Increase C B HOLD TIME set point in synchroscope menu. See description of set points. |
| | Faulty wiring on C.B. Aux contacts | Verify wiring of C.B. Aux contacts to EGCP-2 input. |
| Breaker close relay stays energized when a close command is given and never issues an open command | C B CONTROL set point is set for CONTACTOR | Appropriately set the C B CONTROL set point in configuration menu. See description of set points. |

Real Load Control

| Problem | Probable Cause | Corrective Action |
|---|---|---|
| kW for a phase(s) reads negative. | Current transformer(CT) has reversed polarity | Verify/reverse polarity of current transformer for effected channel(s) IMPORTANT Engine generator set must be off to safely open circuit a current transformer. |
| Unit carries improper proportion of real load during isochronous load sharing | Rated KW set point in configuration menu set at incorrect value | Appropriately set Rated KW set point in configuration menu. See description of set points. |
| | A proportional dc speed error exists on the speed control unit (no-load speed not set to match bus frequency) | Adjust speed setting of speed control to match the bus frequency. If unit is carrying too little load, the speed setting needs increased. If unit is carrying too much load, the speed setting needs decreased. |
| Real load control is unstable when paralleled with the mains source | Real load control dynamics in real load control menu are improperly set up | Tune Real load control dynamics in real load control menu. See description of set points. |
| Process control operation causes overload or reverse power | PROCESS ACTION set point in process control menu set for incorrect action | Appropriately set PROCESS ACTION set point in process control menu. See description of set points. |
| Loading and/or unloading is too fast/slow | Load and/or unload ramp rates in the real load control menu are set incorrectly | Appropriately increase/decrease the Load and/or unload ramp rates in the real load control menu. See description of set points. |
| Engine speed/load has an instability that fluctuates very quickly. | Speed control dynamics are improperly set up | Tune the speed control dynamics for stable operation. See speed control manufacturer's instruction manual for more details. |

Reactive Load Control

| Problem | Probable Cause | Corrective Action |
|--|--|---|
| Phase power factors do not agree. Two of the three phases are extremely far out of range | CT's are connected to incorrect phase inputs | Verify CT's are connected to the appropriate input terminals. IMPORTANT Engine generator set must be off to safely open circuit a current transformer. |
| Unit carries improper proportion of reactive load during isochronous load sharing | Rated kVA set point in the configuration menu is set at incorrect value | Appropriately set the Rated kVA set point in the configuration menu. See description of set points. |
| | Generator A phase PT input(s) are improperly calibrated | Calibrate the Generator A phase PT input(s) of the generator set(s). See calibration of control inputs and outputs. |
| Reactive load control is unstable when paralleled with the mains source | Reactive load control dynamics in the reactive load control menu are improperly set up | Tune the Reactive load control dynamics in the reactive load control menu. See description of set points. |
| Unit maintains a constant VAR load rather than a constant power factor when paralleled with the mains source | VAR/PF set point in the reactive load control menu is set to VAR CONTROL | Appropriately set the VAR/PF set point in the reactive load control menu. See description of set points. |
| Unit maintains a constant power factor load rather than a constant VAR when paralleled with the mains source | VAR/PF set point is set to PF CONTROL | Appropriately set the VAR/PF set point in the reactive load control menu. See description of set points. |
| Multiple generator sets are unstable when VAR/PF sharing at light loads | VOLTS RAMP TIME set point in reactive load control menu is not adjusted properly | Appropriately set the VOLTS RAMP TIME set point in reactive load control menu. See description of set points. |
| | Droop Current Transformer not properly connected to AVR | Verify the connection of the Droop Current Transformer to the AVR. See AVR manufacturer's instruction manual for more details. |

Sequencing

| Problem | Probable Cause | Corrective Action |
|---|--|---|
| Unit number(s) does not show up in the sequencing order in the sequencing screen/unit doesn't auto sequence | switch in manual position | Switch unit(s) to the Auto switch active position. See dc inputs/outputs. |
| | Automatic sequencing set point in the configuration menu set to disabled | ENABLE the Automatic sequencing set point in the configuration menu. See description of set points. |
| | Unit has an active alarm | Commit or reset alarm condition(s). See description of screens. |
| | RS-485 Network not connected at unit(s) | Verify that the RS-485 network is connected to all EGCP-2 controls in system. |
| | RS-485 Network is inadequately terminated | Verify that the RS-485 Network is correctly terminated. See inter-control communications (RS-485). |
| When system load is large enough to require additional gen-sets, more than one set is sequenced on line | NEXT GENSET DELAY set point in sequencing menu is too short | Increase NEXT GENSET DELAY set point in sequencing menu. See description of set points. |
| | MAX START TIME set point in sequencing menu is too short | Increase MAX START TIME set point in sequencing menu. See description of set points. |
| When system load is small enough to take additional sets off line, more than one set is sequenced off line | REDUCED LOAD DELAY set point in sequencing menu is too short | Increase REDUCED LOAD DELAY set point in sequencing menu. See description of set points. |
| | MAX STOP TIME set point in sequencing menu is too short | Increase MAX STOP TIME set point in sequencing menu. See description of set points. |

Mains/Bus Sensing

| Problem | Probable Cause | Corrective Action |
|---|--|--|
| Unit(s) do not respond to loss of mains | Shutdown/alarm set points for mains sensing not set for LOSS OF MAINS | Appropriately set mains high/low frequency and high/low voltage set points in shutdown/alarm menu. See description of set points. |
| | Unit(s) do not have an active auto switch input | Switch unit(s) to the Auto switch active position. See dc inputs/outputs. |
| Unit does not recognize when mains are in spec. | Set points for mains high/low frequency and high/low voltage in shutdown/alarm menu are set too tight for sensing when mains are in spec | Increase Mains high frequency and voltage and decrease mains low frequency and voltage set points in the shutdown/alarm menu. See description of set points. |

Communications

| Problem | Probable Cause | Corrective Action |
|--|--|--|
| A unit number(s) does not show up in the sequencing order in the sequencing screen | RS-485 Network is inadequately terminated | Verify that the RS-485 Network is correctly terminated. See inter-control communications (RS-485). |
| | RS-485 Network not connected at unit(s) | Verify that the RS-485 Network is connected to the EGCP-2 RS-485 input at all units. |
| | RS-485 network is connected with reverse polarity at one or more units | Verify the polarity of the RS-485 network on all units. |
| If a unit with the network termination is powered down, communications become unreliable or completely cease | +5 Vdc power supply is not linked between units (inadequate wiring) | Verify that the +5 Vdc power supply is linked between all units. |

Chapter 9.

Definition of Terms

- AMF** Automatic Mains Failure. The ability of a control to detect, and take action on a mains failure condition. The EGCP-2, which has AMF capabilities, can be programmed to sense a loss of mains condition based on mains voltage, frequency, or a sudden load surge on a generator operating in parallel with the mains. The action taken by the EGCP-2 when it senses a mains failure can be programmed for either an alarm action, or a standby power action where all generators start and tie to the load after the failed mains have been isolated from that load.
- Automatic Control** A control mode used by the EGCP-2 to activate several automatic functions within the control. These functions, which are dependent upon program set points and system configuration, are Loss of Mains detection, Automatic Sequencing, and Automatic dead bus closing, Automatic control also effectively connects those EGCP-2 units in automatic to the Local Operating Network (LON).
- Auto Switch** A discrete input to the control that will initiate automatic operation of the EGCP-2.
- ATS** Automatic Transfer Switch. A device that isolates the mains upon a sensed fault in the mains, or through manual operation. The ATS selects a secondary power source, such as a diesel generator to supply the load when the mains have been isolated. The ATS will also re-connect the load to the mains when they are re-established and stable. The EGCP-2 control has ATS functions.
- Audible Alarm** An alarm condition used by the EGCP-2 for various alarm settings which will cause the audible alarm relay output to energize when reaching or exceeding the alarm parameters.
- Automatic Sequencing** The automatic addition, or subtraction of generators to/from the load based on predetermined load levels being crossed for specific periods of time. Automatic sequencing is a function of a multiple generator system that is operating in load sharing mode isolated from the mains, or process control mode in parallel with the mains.

| | |
|-------------------------|---|
| AVR | Automatic Voltage Regulator. A device that controls the field excitation of an AC generator in such a way as to maintain a specific voltage level over the operating load range of the generator. The EGCP-2 control biases the voltage setting of the AVR to voltage match during synchronization and to control reactive load during load share and mains parallel operation. |
| Base Load | A term used to describe a generator loading condition in which the generator is paralleled to another source of power, typically the mains, and loaded to a fixed kW level. The generator maintains this kW level regardless of load on the Mains. |
| Breaker | A device used to connect one power source to a load, or to another power source. Breakers can be either manually or automatically operated, and will usually contain overcurrent protection. The EGCP-2 controls motorized breakers by issuing a momentary breaker close output to energize the breaker coil, and a separate breaker open output to shunt trip the breaker to open it. |
| Contactor | A device used to connect one power source to a load, or to another power source. Contactors are typically automatic in operation, and are energized for closure from an external source. The EGCP-2 controls contactors by issuing a contactor close output to close the contactor, and removing this output to open the contactor. |
| CT | Current Transformer. A device used to sense current levels on a high current source, such as a generator. The secondary side of the current transformer supplies a lower current signal that is safe to feed into metering and control devices. The EGCP-2 uses 5A secondary current CTs for its current sensing inputs from the three phases of the generator. |
| Dead Bus Closing | The ability of a generator breaker control device to sense, and safely close on to a load which has no other generators or sources of power tied to it. Dead Bus Closing must not allow two generators to attempt closure to the dead bus at the same time, since an out of phase paralleling situation would likely occur. The EGCP-2 uses its Local Operating Network to insure safe dead bus closing among all units tied to this network. The units have a single dead bus token, which allows the unit possessing it to close to the dead bus. Only one token exists on the network, so there is no possibility of multiple units closing to the dead bus simultaneously. Dead Bus Closing is always active in single unit configurations. |

| | |
|---------------------------|--|
| Droop | A reduction in the reference of a controlled parameter as the amplitude of that parameter increases (negative feedback). The EGCP-2 uses Kilowatt Droop as a manual means of loading the generator when paralleling to another generator, or to the mains. Droop Control is effective only if the LOAD CONTROL MODE set point in the Configuration menu is set to DROOP. |
| Dwell Time | A term used to describe the amount of time required during synchronization in which one power source is within a specified phase angle window of another source it is synchronizing to. |
| Hard Shutdown | A shutdown condition used by the EGCP-2 for various alarm settings that will cause the unit to immediately open its generator breaker if on load, and shut down when reaching or exceeding the alarm parameters. |
| Isochronous | A term which is used to describe a generator set that will maintain its frequency at a constant level as the load on that generator changes. The EGCP-2 typically uses Isochronous load control when in load sharing, or when operating as a single unit. This assures a constant frequency under all generator loads that are within the capacity of the generator. |
| Inverse Time Delay | A time delay used for overcurrent and reverse power detection that utilizes both time and amplitude of the condition to determine the active trip level. The inverse time delay accounts for rapid high amplitude conditions to cause a trip, as well as long duration low amplitude conditions. |
| Isolated Bus | A bus which is electrically isolated from the mains. |
| kVA | Kilovolt Amps. The power rating of the generator set kVA is determined by multiplying the rated voltage of the generator by the rated current. |
| kVAR | Kilovolt Amps Reactive. Reactive load is produced by a phase angle differential between the volts and the amps of the generator. kVAR can either be a product of inductive or capacitive loads when operating on an isolated bus, or can be produced by the generator when operating in parallel with another power source such as the mains. |
| kW | Kilowatts. The Watts are the product of the voltage of the generator and the current that is produced within the voltage cycle. kW load is resistive in nature. |
| Load | Typically the kW load on the generator at any given time. |

| | |
|-------------------------|---|
| Load Surge | A condition in which a step load on the generator, which is operating in a mains parallel mode (base load or process), above a certain amplitude can be used to trigger a Loss of Mains condition. |
| Loss of Mains | A condition in which the sensed mains PT input to the EGCP-2 falls below certain voltage and/or frequency set points for a given period of time. Load Surge can also be used to detect a Loss of Mains condition. The EGCP-2 can be configured to trigger a Loss of Mains (LOM) reaction to these conditions, and provide on site power generation to supplement the load until such time as the mains return and are stable. |
| Mains Parallel | To synchronize and close an operating generator to the mains. The EGCP-2 can be configured for Mains Parallel operation. |
| Master | The Highest Priority unit in an operating automatic system. The Master Control controls load sharing, VAR/PF sharing, sequencing, synchronization to the mains, mains breaker closure/opening, and multiple unit starting. |
| Manual | A switch input to the EGCP-2 that puts the control in a manual operating mode. When in manual, the EGCP-2 does not communicate with other units on the network, and if in a multiple unit system, will not issue a dead bus closing command. Being in manual also cancels any Loss of Mains detection for that particular unit. |
| Network Address | A unique address assigned to each unit that is operating in an automatic system. The network address is that particular unit's "name" on the network so that it can be properly identified by other units operating on the same network. |
| Network Priority | A unique number assigned to each unit operating in automatic on the network. Network priority defines the sequence in which units will be taken on/off load when operating in an automatic sequencing configuration (load sharing or process control). Automatic sequencing will place units on load as required starting at the highest network priority (lowest numerical value), and adding units of lower priority (higher numerical value) as the load on that system increases above certain defined limits. Automatic sequencing will also remove units from the load in a reverse order of that used for sequencing units on load, that is from lowest priority (highest numerical value) to highest priority (lowest numerical value). |

In addition to all this, the unit with the highest network priority on the network is considered the master, and all other units with lower priorities are slaves to that master.

| | |
|----------------------------------|---|
| No Parallel | An operating mode of the EGCP-2 that will not allow the generators to operate in parallel with the mains under any circumstances. All transitions to and from the mains are completed using an open transition action. |
| Parallel | To synchronize and close an operating generator to the mains. |
| Power Triangle | A right triangle that is used to determine the amplitude relationship between kVA, kW, and kVAR. |
| Process Control | A switch input that selects a mode of control used while in parallel with the mains. When operating in process control, the EGCP-2 receives a 4–20 mA, or 1–5 Vdc input from an external transducer. This transducer monitors a variable that is affected by the generator operation. Variables such as imported power to a site, exported power to the mains, exhaust temperature, and fuel gas pressure levels are typical for monitoring with a transducer. The EGCP-2 uses an internal reference level for the process input, and compares this reference to the transducer input. The EGCP-2 then raises or lowers the amount of load on the generator to maintain the process transducer input to the referenced value. |
| Proportional Load Sharing | A mode of load control used by the EGCP-2 while operating multiple units on an isolated bus. Proportional Load Sharing measures the total kVA capacity of all the units on the bus and divides the total kVA load on the bus by this capacity. This value is then sent over the network as a load reference for all units operating in parallel on the bus. The result of this is the ability of various kVA rated units operating at their respective proportion of the total load on the bus. This allows consistent load sharing among units of various sizes throughout their entire operating load range. |
| PT | Potential Transformer. A device that steps down a higher AC voltage to a lower AC voltage. Typically used on generator set applications to step the generator voltage down to an amplitude that is safe for use in metering and control devices. |
| Run With Load | A discrete input to the EGCP-2 that signals the unit to operate the generator on load. The way that the control puts the generator on load depends upon software configuration, and the type of system the EGCP-2 is configured for. |

| | |
|-----------------------|---|
| Slave | An EGCP-2 with lower network priority (Higher numerical value) than the master. |
| Soft Shutdown | A shutdown condition used by the EGCP-2 for various alarm settings, which will cause the unit to softly unload and cooldown when reaching or exceeding the alarm parameters. |
| Soft Transfer | A Load Control Mode of the EGCP-2 which allows the unit, or group of units to transfer power from the mains to the on site generators. Upon reaching either a base load reference, or process control reference level, the EGCP-2 will issue a command to open the mains breaker. This results in a complete transition of power from the mains to the on site generators. |
| Synchronize | To match the frequency, phase angle, and voltage of a generator to another power source such as a generator or the mains. This will allow a safe smooth breaker closure of that generator to the power source. The EGCP-2 uses Phase and Voltage Matching to ensure there is a minimum of potential across the breaker prior to closure. |
| System Load | A variable used in the load control program of the EGCP-2, which is the ratio of total load demand to total generating capacity that is supplying the load. System Load = kW Load/kW Capacity. |
| Test | A discrete input to the EGCP-2, which is used to start the engine for test and initial start check out. The test input is also used with the run with load or process inputs, and a software set point, to put the EGCP-2 into a soft transfer mode. |
| VAR/PF Control | The ability to control a level of VAR or PF on a generator while in parallel with the mains. The EGCP-2 has VAR/PF control features that allow the user to set a desired VAR or PF level on the generator while in parallel with the mains. The VAR or PF level is maintained by changing the excitation level of the generator. This is accomplished by changing the voltage reference level of the AVR from the EGCP-2. |
| VAR/PF Sharing | The ability to share the VAR and PF load on multiple units operating on an isolated bus. Like load sharing, the EGCP-2 VAR/PF sharing measures the VARs of the load on the isolated bus, and divides this value by the total VAR capacity of the generators tied to the load. A proportional VAR/PF level is then maintained between all units tied to the load based on their rated VAR capacity. |

Chapter 10.

Service Options

Product Service Options

If you are experiencing problems with the installation, or unsatisfactory performance of a Woodward product, the following options are available:

- Consult the troubleshooting guide in the manual.
- Contact the manufacturer or packager of your system.
- Contact the Woodward Full Service Distributor serving your area.
- Contact Woodward technical assistance (see “How to Contact Woodward” later in this chapter) and discuss your problem. In many cases, your problem can be resolved over the phone. If not, you can select which course of action to pursue based on the available services listed in this chapter.

OEM and Packager Support: Many Woodward controls and control devices are installed into the equipment system and programmed by an Original Equipment Manufacturer (OEM) or Equipment Packager at their factory. In some cases, the programming is password-protected by the OEM or packager, and they are the best source for product service and support. Warranty service for Woodward products shipped with an equipment system should also be handled through the OEM or Packager. Please review your equipment system documentation for details.

Woodward Business Partner Support: Woodward works with and supports a global network of independent business partners whose mission is to serve the users of Woodward controls, as described here:

- A **Full Service Distributor** has the primary responsibility for sales, service, system integration solutions, technical desk support, and aftermarket marketing of standard Woodward products within a specific geographic area and market segment.
- An **Authorized Independent Service Facility (AISF)** provides authorized service that includes repairs, repair parts, and warranty service on Woodward's behalf. Service (not new unit sales) is an AISF's primary mission.
- A **Recognized Engine Retrofitter (RER)** is an independent company that does retrofits and upgrades on reciprocating gas engines and dual-fuel conversions, and can provide the full line of Woodward systems and components for the retrofits and overhauls, emission compliance upgrades, long term service contracts, emergency repairs, etc.
- A **Recognized Turbine Retrofitter (RTR)** is an independent company that does both steam and gas turbine control retrofits and upgrades globally, and can provide the full line of Woodward systems and components for the retrofits and overhauls, long term service contracts, emergency repairs, etc.

You can locate your nearest Woodward distributor, AISF, RER, or RTR on our website at:

www.woodward.com/directory

Woodward Factory Servicing Options

The following factory options for servicing Woodward products are available through your local Full-Service Distributor or the OEM or Packager of the equipment system, based on the standard Woodward Product and Service Warranty (5-01-1205) that is in effect at the time the product is originally shipped from Woodward or a service is performed:

- Replacement/Exchange (24-hour service)
- Flat Rate Repair
- Flat Rate Remanufacture

Replacement/Exchange: Replacement/Exchange is a premium program designed for the user who is in need of immediate service. It allows you to request and receive a like-new replacement unit in minimum time (usually within 24 hours of the request), providing a suitable unit is available at the time of the request, thereby minimizing costly downtime. This is a flat-rate program and includes the full standard Woodward product warranty (Woodward Product and Service Warranty 5-01-1205).

This option allows you to call your Full-Service Distributor in the event of an unexpected outage, or in advance of a scheduled outage, to request a replacement control unit. If the unit is available at the time of the call, it can usually be shipped out within 24 hours. You replace your field control unit with the like-new replacement and return the field unit to the Full-Service Distributor.

Charges for the Replacement/Exchange service are based on a flat rate plus shipping expenses. You are invoiced the flat rate replacement/exchange charge plus a core charge at the time the replacement unit is shipped. If the core (field unit) is returned within 60 days, a credit for the core charge will be issued.

Flat Rate Repair: Flat Rate Repair is available for the majority of standard products in the field. This program offers you repair service for your products with the advantage of knowing in advance what the cost will be. All repair work carries the standard Woodward service warranty (Woodward Product and Service Warranty 5-01-1205) on replaced parts and labor.

Flat Rate Remanufacture: Flat Rate Remanufacture is very similar to the Flat Rate Repair option with the exception that the unit will be returned to you in “like-new” condition and carry with it the full standard Woodward product warranty (Woodward Product and Service Warranty 5-01-1205). This option is applicable to mechanical products only.

Returning Equipment for Repair

If a control (or any part of an electronic control) is to be returned for repair, please contact your Full-Service Distributor in advance to obtain Return Authorization and shipping instructions.

When shipping the item(s), attach a tag with the following information:

- return authorization number;
- name and location where the control is installed;
- name and phone number of contact person;
- complete Woodward part number(s) and serial number(s);
- description of the problem;
- instructions describing the desired type of repair.

Packing a Control

Use the following materials when returning a complete control:

- protective caps on any connectors;
- antistatic protective bags on all electronic modules;
- packing materials that will not damage the surface of the unit;
- at least 100 mm (4 inches) of tightly packed, industry-approved packing material;
- a packing carton with double walls;
- a strong tape around the outside of the carton for increased strength.

NOTICE

To prevent damage to electronic components caused by improper handling, read and observe the precautions in Woodward manual 82715, *Guide for Handling and Protection of Electronic Controls, Printed Circuit Boards, and Modules*.

Replacement Parts

When ordering replacement parts for controls, include the following information:

- the part number(s) (XXXX-XXXX) that is on the enclosure nameplate;
- the unit serial number, which is also on the nameplate.

Engineering Services

Woodward offers various Engineering Services for our products. For these services, you can contact us by telephone, by email, or through the Woodward website.

- Technical Support
- Product Training
- Field Service

Technical Support is available from your equipment system supplier, your local Full-Service Distributor, or from many of Woodward's worldwide locations, depending upon the product and application. This service can assist you with technical questions or problem solving during the normal business hours of the Woodward location you contact. Emergency assistance is also available during non-business hours by phoning Woodward and stating the urgency of your problem.

Product Training is available as standard classes at many of our worldwide locations. We also offer customized classes, which can be tailored to your needs and can be held at one of our locations or at your site. This training, conducted by experienced personnel, will assure that you will be able to maintain system reliability and availability.

Field Service engineering on-site support is available, depending on the product and location, from many of our worldwide locations or from one of our Full-Service Distributors. The field engineers are experienced both on Woodward products as well as on much of the non-Woodward equipment with which our products interface.

For information on these services, please contact us via telephone, email us, or use our website: www.woodward.com.

How to Contact Woodward

For assistance, call one of the following Woodward facilities to obtain the address and phone number of the facility nearest your location where you will be able to get information and service.

| Electrical Power Systems | | Engine Systems | | Turbine Systems | |
|---------------------------------|---------------------|-----------------------|---------------------|------------------------|---------------------|
| <u>Facility</u> | <u>Phone Number</u> | <u>Facility</u> | <u>Phone Number</u> | <u>Facility</u> | <u>Phone Number</u> |
| Brazil | +55 (19) 3708 4800 | Brazil | +55 (19) 3708 4800 | Brazil | +55 (19) 3708 4800 |
| China | +86 (512) 6762 6727 | China | +86 (512) 6762 6727 | China | +86 (512) 6762 6727 |
| Germany | +49 (0) 21 52 14 51 | Germany | +49 (711) 78954-510 | India | +91 (129) 4097100 |
| India | +91 (129) 4097100 | India | +91 (129) 4097100 | Japan | +81 (43) 213-2191 |
| Japan | +81 (43) 213-2191 | Japan | +81 (43) 213-2191 | Korea | +82 (51) 636-7080 |
| Korea | +82 (51) 636-7080 | Korea | +82 (51) 636-7080 | The Netherlands | +31 (23) 5661111 |
| Poland | +48 12 295 13 00 | The Netherlands | +31 (23) 5661111 | Poland | +48 12 295 13 00 |
| United States | +1 (970) 482-5811 | United States | +1 (970) 482-5811 | United States | +1 (970) 482-5811 |

You can also locate your nearest Woodward distributor or service facility on our website at:

www.woodward.com/directory

Technical Assistance

If you need to telephone for technical assistance, you will need to provide the following information. Please write it down here before phoning:

Your Name _____

Site Location _____

Phone Number _____

Fax Number _____

Engine/Turbine Model Number _____

Manufacturer _____

Number of Cylinders (if applicable) _____

Type of Fuel (gas, gaseous, steam, etc) _____

Rating _____

Application _____

Control/Governor #1

Woodward Part Number & Rev. Letter _____

Control Description or Governor Type _____

Serial Number _____

Control/Governor #2

Woodward Part Number & Rev. Letter _____

Control Description or Governor Type _____

Serial Number _____

Control/Governor #3

Woodward Part Number & Rev. Letter _____

Control Description or Governor Type _____

Serial Number _____

If you have an electronic or programmable control, please have the adjustment setting positions or the menu settings written down and with you at the time of the call.

Appendix A. Connector Information

Wago pluggable style terminal blocks are used on the EGCP-2 to connect the field wiring to the control. THESE CONNECTORS ARE NOT INCLUDED WITH THE EGCP-2. Woodward carries the EGCP-2 connector kit, which contains all of the terminal blocks used on the EGCP-2 as part number 8928-301.

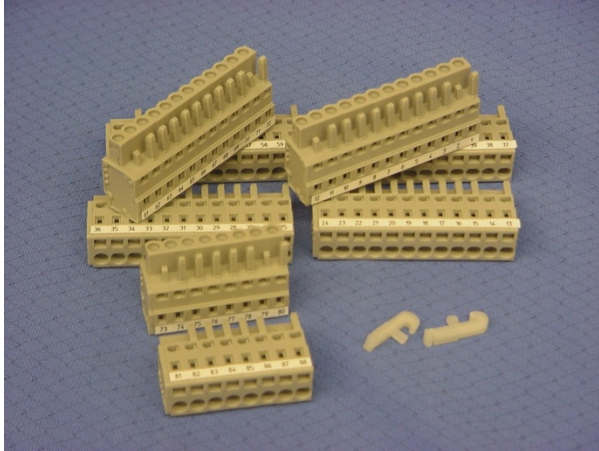

EGCP-2 Connector Kit

Woodward P/N WAGO P/N

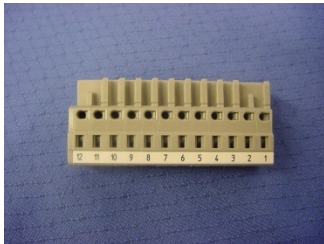

12 pole connector 1751-760 231-112/026-000

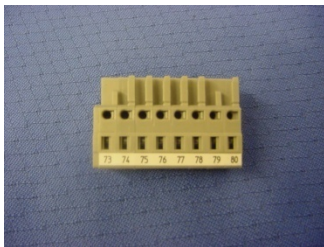

8 pole connector 1751-756 231-108/026-000



Levers 1751-899 231-131

Woodward provides labels (P/N 3061-303) only as part of the connector kit.

Recommended Wire Types:

| Size | Insulation | Type | Use |
|---------------------------------|-------------------|--|--|
| 0.3 mm ² / 22 AWG | 600V | Multiple conductor, unshielded | Discrete I/O PT inputs |
| 0.3 mm ² / 22 AWG | 300V | Two conductor, shielded | Speed Bias, Voltage Bias, MPU, Oil and Water Sensors |
| 1.0 mm ² / 16 AWG | 600V | Four conductor stranded, unshielded | CT inputs |
| 0.3 mm ² / 22 AWG | 30V | Two conductor stranded, twisted pair, shielded, 124 Ω impedance | RS-485 RS-422 (TX and RX) |

Appendix B. Speed Bias Connections

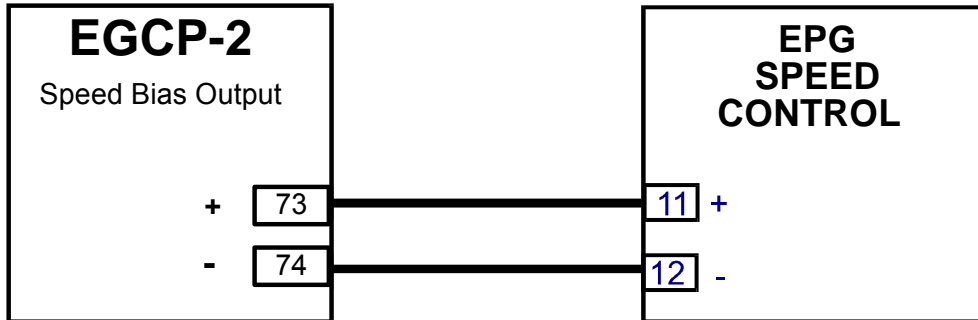

EGCP-2 To EPG Speed Control Wiring and Configuration Settings

Speed Bias Output Type = +/- 3VDC
 0% Speed Bias equals 0 volts DC (Factory set)

VIS-125a
 00-06-20

EPG Speed Controls (common numbers)
 8290-184, 8290-185, 8290-186, 8290-187

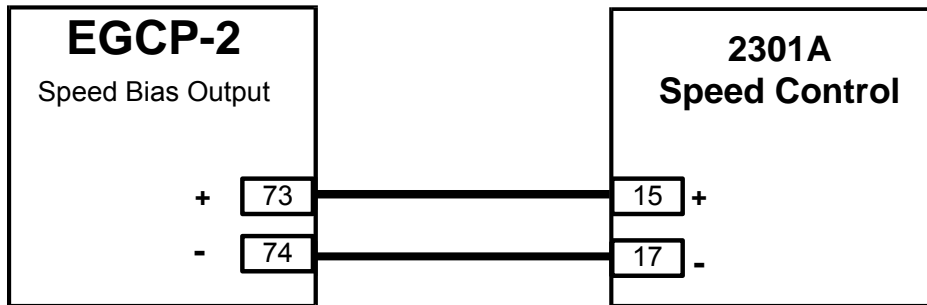

EGCP-2 To 2301A Speed Control Wiring and Configuration Settings

Speed Bias Output Type = +/- 3VDC
 0% Speed Bias Output = 0 VDC

VIS-126a
 00-06-20

Common 2301A Speed Control Part Numbers:
 9905-131, 9905-376, 9907-014

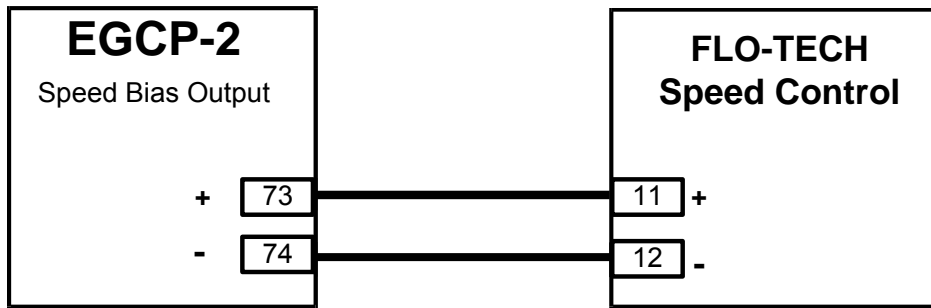

EGCP-2 To FLO-TECH Speed Control Wiring and Configuration Settings

Speed Bias Output Type = +/- 3VDC
0% Speed Bias Output = 0 VDC

VIS-127a
00-06-20

Common FLO-TECH Speed Control Part Numbers:
8290-195, 8290-196

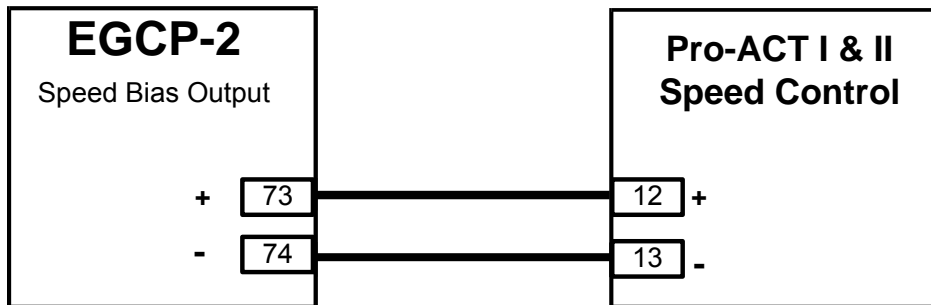

EGCP-2 To Pro-ACT Speed Control Wiring and Configuration Settings

Speed Bias Output Type = +/- 3VDC
0% Speed Bias Output = 0 VDC

VIS-128a
00-06-20

Common Pro-ACT Speed Control Part Numbers:
9905-462, 9905-463

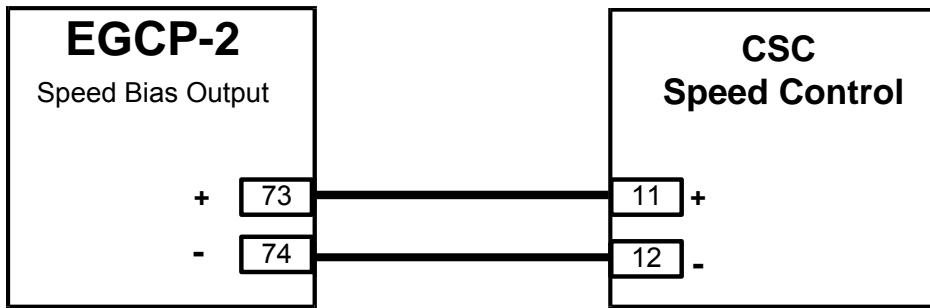

EGCP-2 To CSC Speed Control Wiring and Configuration Settings

Speed Bias Output Type = +/- 3VDC
 0% Speed Bias Output = 0 VDC

VIS-129a
 00-06-20

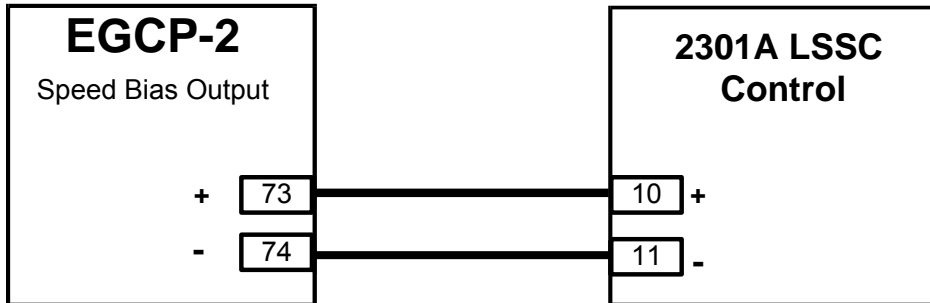

EGCP-2 To 2301A LSSC Wiring and Configuration Settings

Speed Bias Output Type = +/- 3VDC
 0% Speed Bias Output = 0 VDC

VIS-130a
 00-06-20

NOTE: 2301A LSSC must have terminal 14 powered for the load sharing line inputs (10 and 11) to be active.

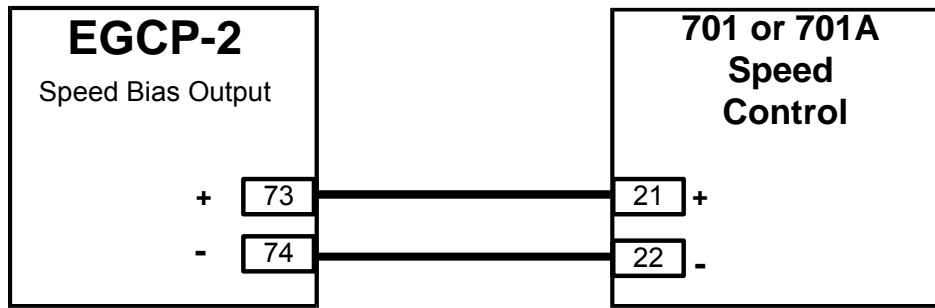

EGCP-2 To 701 and 701A Wiring and Configuration Settings

Speed Bias Output Type = +/- 3VDC
 0% Speed Bias Output = 0 VDC

VIS-131a
 00-06-20

Common 701 and 701A Speed Control Part Numbers:
 8280-102, 8280-193, 9905-211

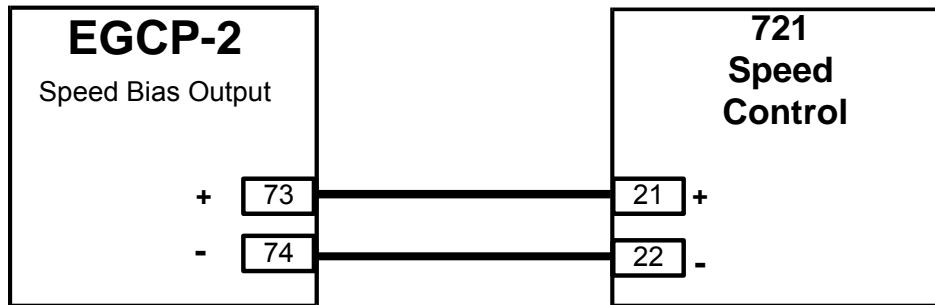

EGCP-2 To 701 and 701A Wiring and Configuration Settings

Speed Bias Output Type = +/- 3VDC
 0% Speed Bias Output = 0 VDC

VIS-132a
 00-06-20

Common 721 Speed Control Part Numbers:
 9905-291, 9907-206, 9907-207

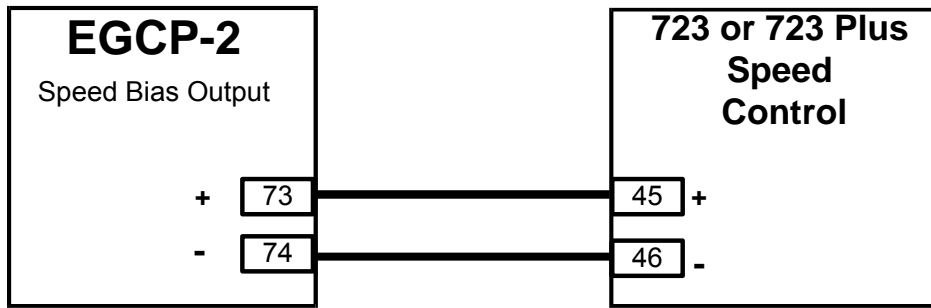

EGCP-2 To 723 or 723 Plus Wiring and Configuration Settings

Speed Bias Output Type = +/- 3VDC
 0% Speed Bias Output = 0 VDC

VIS-133a
 00-06-20

Common 723 or 723 Plus Speed Control Part Numbers:
 9907-031, 8280-412

Appendix C. Voltage Bias Connections

Basler AVC63-12

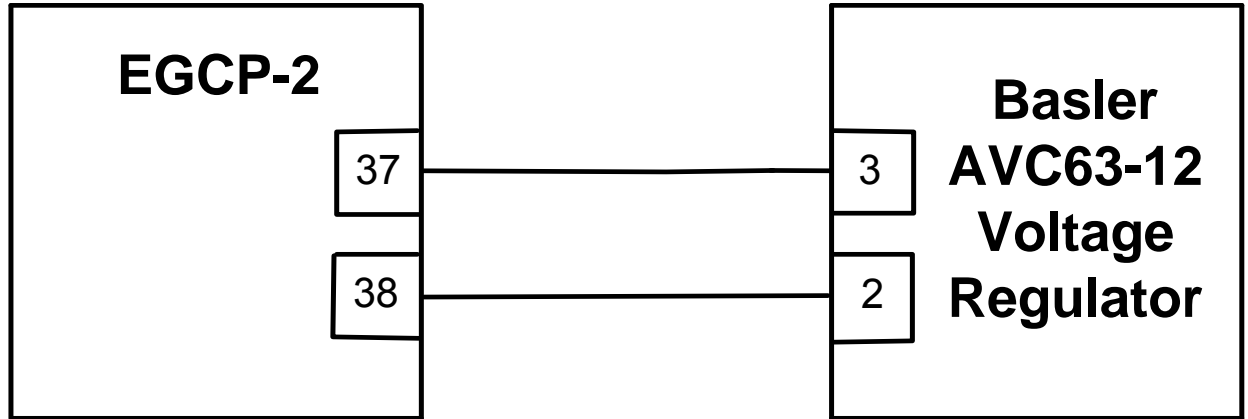

EGCP-2 settings:

Configuration Menu

Voltage Bias Type: +/- 1 VDC

Calibration Menu

Volts Bias Offset: 0%

Shutdown & Alarms Menu

Gen Volt Hi Lmt: * 10% above
rated

Gen Volt Lo Lmt: * 10% below
rated

Reactive Load Control Menu

VAR/ PF Gain: 1.0

Volts Ramp Time: 100

VAR/ PF Sharing Gain: 0.2

VAR/ PF Stability: 2.0

PF Deadband: 0.005

* - These are only
suggested values

Voltage Regulator settings:

Drop - set for 2 to 5 %

In a multiple generator system, set
droop the same on all regulators

Terminals 2 and 3 will provide
a 10% per volt range

Adjustment Procedure

1. Start the generator with the EGCP-2 NOT connected and set for rated voltage. Terminals 2 and 3 on the AVR must be jumpered when doing this.
2. Connect the EGCP-2 as shown.
3. Start Generator
4. Adjust the Volts Bias Offset for rated voltage.
5. Press ENTER to save this value
6. Close the Voltage Raise discrete input (4) and verify the EGCP2 can move the generator voltage in the increase direction.
7. Close the Voltage Lower discrete input (5) to verify the EGCP-2 can drive the generator voltage in the decrease direction.

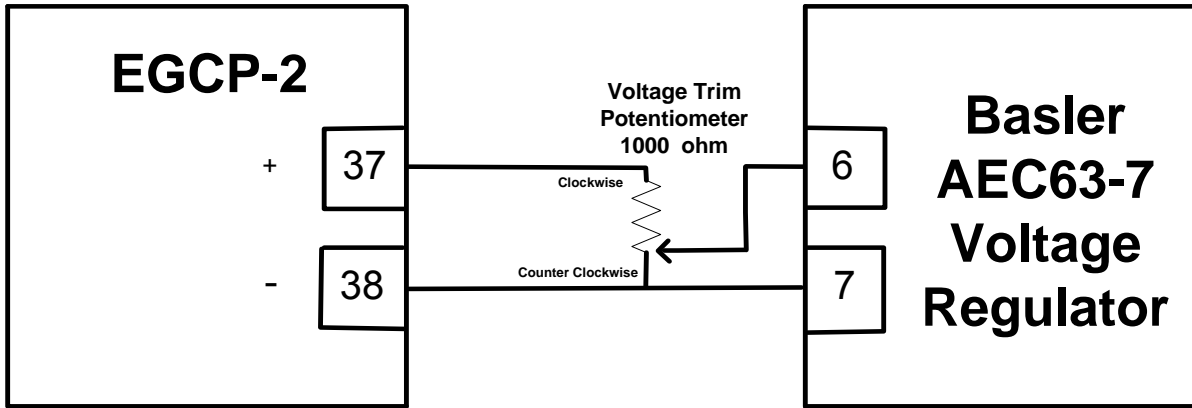
Basler AEC63-7**Voltage Regulator settings:**

Droop - set for 2 to 5 %

In a multiple generator system, set droop the same on all regulators

Voltage Trim Potentiometer:

1000 ohm, 10 Turn, 2 Watt

Set to Mid-range

The value of the Voltage Trim Potentiometer can be anywhere from 1000 to 10,000 ohms (2 Watt). The value of this pot will effect the final settings.

EGCP-2 settings:**Configuration Menu**

Voltage Bias Type: +/- 9 VDC

Calibration Menu

Volts Bias Offset: -30%

Reactive Load Control Menu

VAR/ PF Gain: 1.0

Volts Ramp Time: 200

VAR/ PF Sharing Gain: 0.2

VAR/ PF Stability: 2.0

PF Deadband: 0.005

* - These are only suggested values

Adjustment Procedure

1. Start with the generator at rated voltage (EGCP-2 Not Connected, terminals 6 and 7 should be shorted). Adjust the potentiometers on the AEC63 for rated voltage and stability.
2. Connect the EGCP-2 to the voltage regulator as shown.
3. Configure the EGCP-2 settings as required.
4. Start the generator set.
5. Adjust the Voltage Trim pot rated voltage. Do not adjust this pot after this step.
6. Close the Voltage Raise discrete input. The voltage on the generator should increase.
7. Open the Voltage Raise input.
8. Close the Voltage Lower discrete input until rated voltage is reached.
9. The VAR/PF menu items may need adjusted for stable Power Factor control.

Basler APR63-5

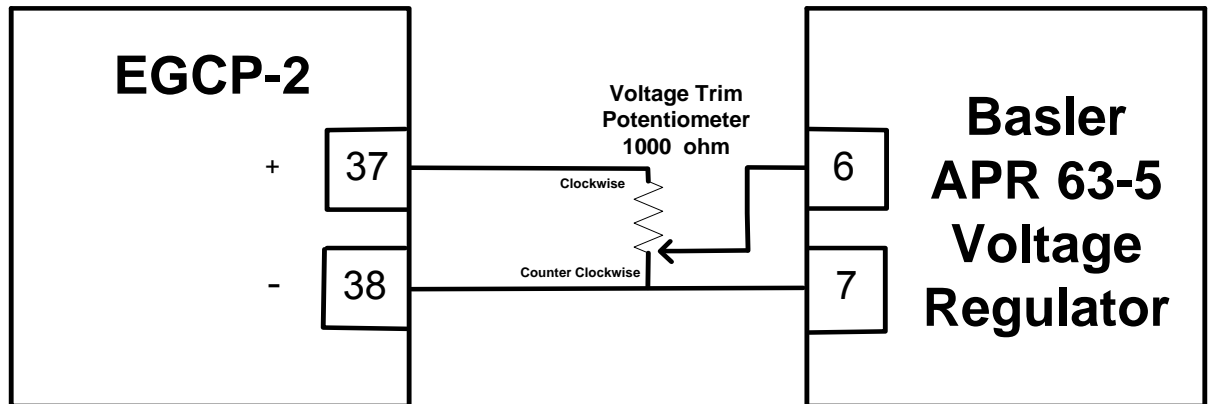
**Adjustment Procedure****Voltage Regulator settings:**

Drop - set for 2 to 5 %
In a multiple generator system, set droop the same on all regulators

Voltage Trim Potentiometer:

1000 ohm, 10 Turn, 2 Watt
Set to Mid-range

The value of the Voltage Trim Potentiometer can be anywhere from 1000 to 10,000 ohms (2 Watt). The value of this pot will effect the final settings.

EGCP-2 settings:**Configuration Menu**

Voltage Bias Type: +/- 9 VDC

Calibration Menu

Volts Bias Offset: -30%
(Press the Status key)

Reactive Load Control Menu

VAR/ PF Gain: 1.0
Volts Ramp Time: 200
VAR/ PF Sharing Gain: 0.2
VAR/ PF Stability: 2.0
PF Deadband: 0.005

*** - These are only suggested values**

1. Start with the generator at rated voltage (EGCP-2 Not Connected). Have the Pot set at mid-range and adjust the potentiometers on the AVR for rated voltage and stability.
2. Place a voltmeter across terminals 6(+) and 7(-) on the AVR. This will be a DC voltage. Write down _____.

3. Connect the EGCP-2 to the voltage regulator as shown.

4. Place the voltmeter across terminals 37(+) and 38(-) on the EGCP-2.

5. Adjust the Volts Bias Offset (**VBO**) until you measure double what step 2 measured. If step 2 measured a -0.8 vdc, then adjust the volts bias offset (EGCP-2) until you measure -1.6 vdc.

When adjusting the VBO you will move the VBO %, press the Enter key, then press the Status key. The new value will then be seen on the voltmeter monitoring terminals 37 and 38.

6. Start the generator set.
7. Adjust the VoltageTrim Pot for rated voltage. Do not adjust this pot after this step.
8. Close the Voltage Raise discrete input. The voltage on the generator should increase.
9. Open the Voltage Raise input.
10. Close the Voltage Lower discrete input until rated generator voltage is reached.
11. The VAR/Power Factor Menu items may need adjusted for stable Power Factor control.

Basler APR63-5 with AMP200

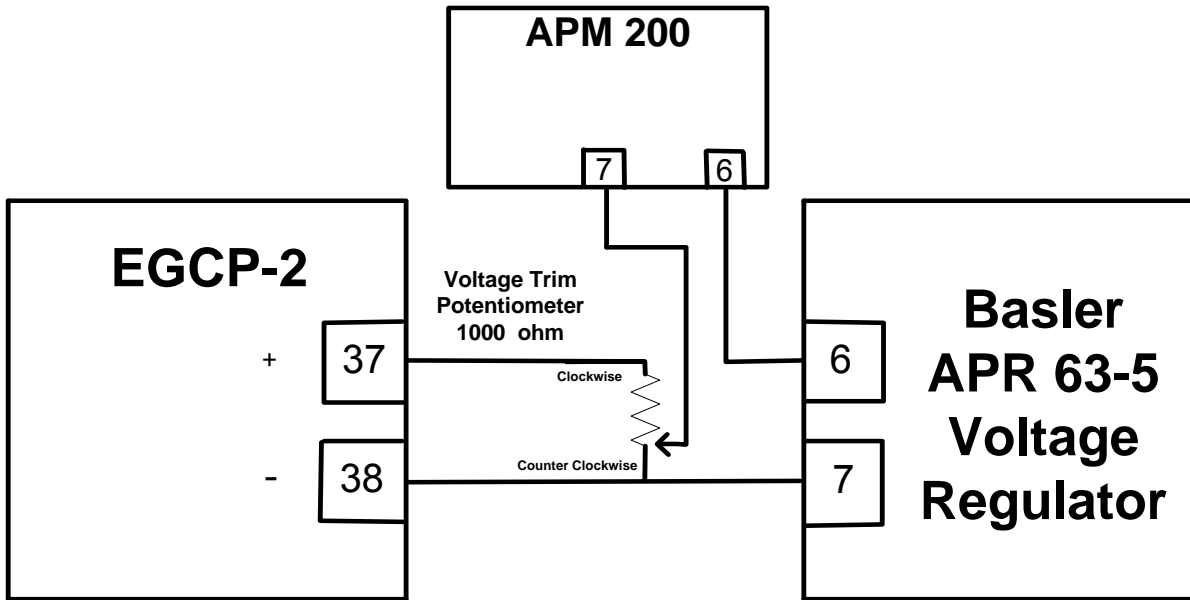

Adjustment Procedure

Voltage Regulator settings:

Droop - set for 2 to 5 %

In a multiple generator system, set droop the same on all regulators

Voltage Trim Potentiometer:

1000 ohm, 10 Turn, 2 Watt

Set to Mid-range

The value of the Voltage Trim Potentiometer can be anywhere from 1000 to 10,000 ohms (2 Watt). The value of this pot will effect the final settings.

EGCP-2 settings:

Configuration Menu

Voltage Bias Type: +/- 9 VDC

Calibration Menu

Volts Bias Offset: -30%

(Press the Status key)

Reactive Load Control Menu

VAR/ PF Gain: 1.0

Volts Ramp Time: 200

VAR/ PF Sharing Gain: 0.2

VAR/ PF Stability: 2.0

PF Deadband: 0.005

*** - These are only suggested values**

1. Start with the generator at rated voltage (EGCP-2 Not Connected). Have the Pot set at mid-range and adjust the potentiometers on the APR 63 for rated voltage and stability.
2. Place a voltmeter across terminals 6(+) and 7(-) on the AVR. This will be a DC voltage. Write down _____.
3. Connect the EGCP-2 to the voltage regulator as shown.
4. Place the voltmeter across terminals 37(+) and 38(-) on the EGCP-2.
5. Adjust the Volts Bias Offset (**VBO**) until you measure double what step 2 measured. If step 2 measured a -0.8 vdc, then adjust the volts bias offset (EGCP-2) until you measure -1.6 vdc.
6. Start the generator set.
7. Adjust the VoltageTrim Pot for rated voltage. Do not adjust this pot after this step.
8. Close the Voltage Raise discrete input. The voltage on the generator should increase.
9. Open the Voltage Raise input.
10. Close the Voltage Lower discrete input until rated generator voltage is reached.
11. The VAR/Power Factor Menu items may need adjusted for stable Power Factor control.

Basler KR2F, 4F, or 7F

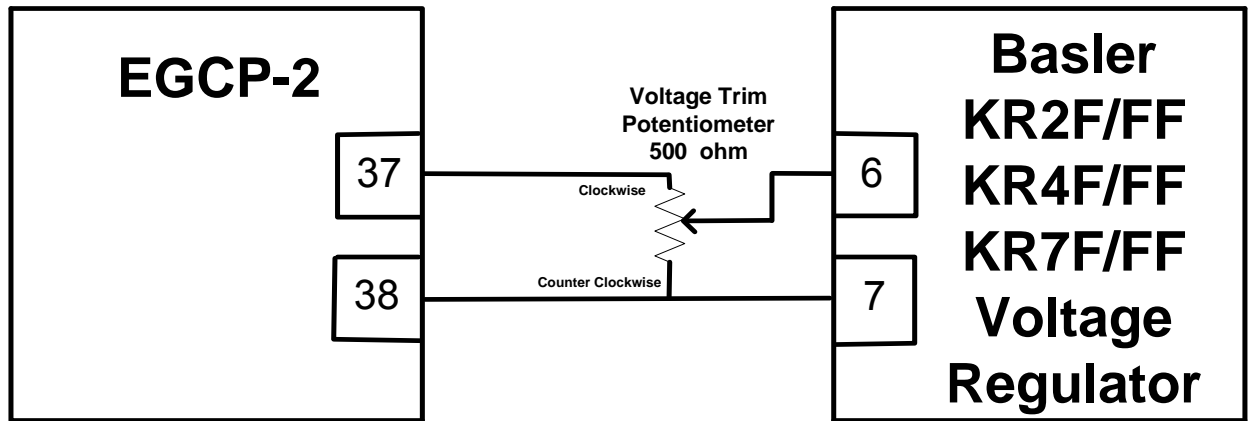
**EGCP-2 settings:****Configuration Menu**

Voltage Bias Type: +/- 3 VDC

Calibration Menu

Volts Bias Offset: -45%

Shutdown & Alarms MenuGen Volt Hi Lmt: * 10 above
ratedGen Volt Lo Lmt: * 10 below
rated**Reactive Load Control Menu**

VAR/ PF Gain: 1.0

Volts Ramp Time: 200

VAR/ PF Sharing Gain: 0.2

VAR/ PF Stability: 2.0

PF Deadband: 0.005

* - These are only
suggested values**Voltage Regulator settings:**

Droop - set for 2 to 5 %

In a multiple generator system, set
droop the same on all regulators**Voltage Trim Potentiometer:**

500 ohm, 10 Turn, 1 Watt

Set to Mid-Range

Adjustment Procedure**Start Generator**

1. Set the Voltage Adjust potentiometer on the KR regulator for Rated Voltage of generator set. (course adjustment)
2. Use the Voltage Trim potentiometer to fine tune the Rated Voltage. This is the potentiometer shown above.
3. The Voltage Trim potentiometer is now calibrated and should not be adjusted anymore.
4. Close the Voltage Raise discrete input (4) and verify the EGCP-2 can move the generator voltage in the increase direction.
5. Close the Voltage Lower discrete input (5) and verify the EGCP-2 can move the generator voltage in the decrease direction.
6. The Reactive Load Menu items may need adjusted for stable Power Factor control.

Basler DECS 15

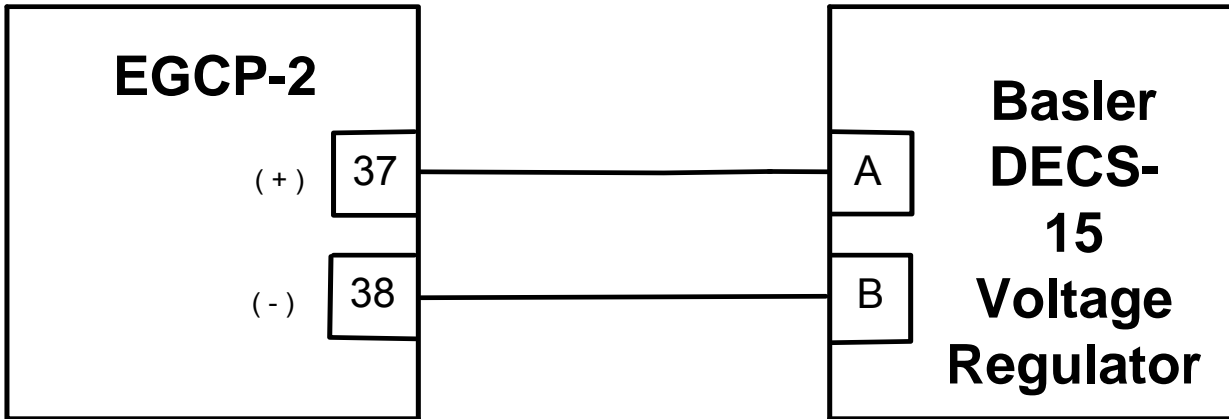
**EGCP-2 settings:****Configuration Menu**

Voltage Bias Type: +/- 1 VDC

Calibration Menu

Volts Bias Offset: 0%

Shutdown & Alarms MenuGen Volt Hi Lmt: * 10% above
ratedGen Volt Lo Lmt: * 10% below
rated**Reactive Load Control Menu**

VAR/ PF Gain: 1.0

Volts Ramp Time: 100

VAR/ PF Sharing Gain: 0.2

VAR/ PF Stability: 2.0

PF Deadband: 0.005

* - These are only
suggested values**Voltage Regulator settings:**

Droop - set for 2 to 5 %

Set droop the same on all regulators

The EGCP-2 is connecting into the
Accessory Voltage Input. The effect of a 1
VDC change is 10% change to the Rated
voltage.**Adjustment Procedure**

1. Start the generator with the EGCP-2 NOT connected. Set DECS for rated voltage
2. Connect the EGCP-2 as shown
3. Start Generator
4. Adjust the Volts Bias Offset for rated voltage.
5. Press ENTER to save this value
6. Close the Voltage Raise discrete input (4) and verify the EGCP2 moves the generator voltage in the increase direction.
7. Close the Voltage Lower discrete input (5) to verify the EGCP-2 drives the generator voltage in the decrease direction.
8. The Reactive Load Control Menu items may need adjusted for stable Power Factor control.

Basler DECS 100

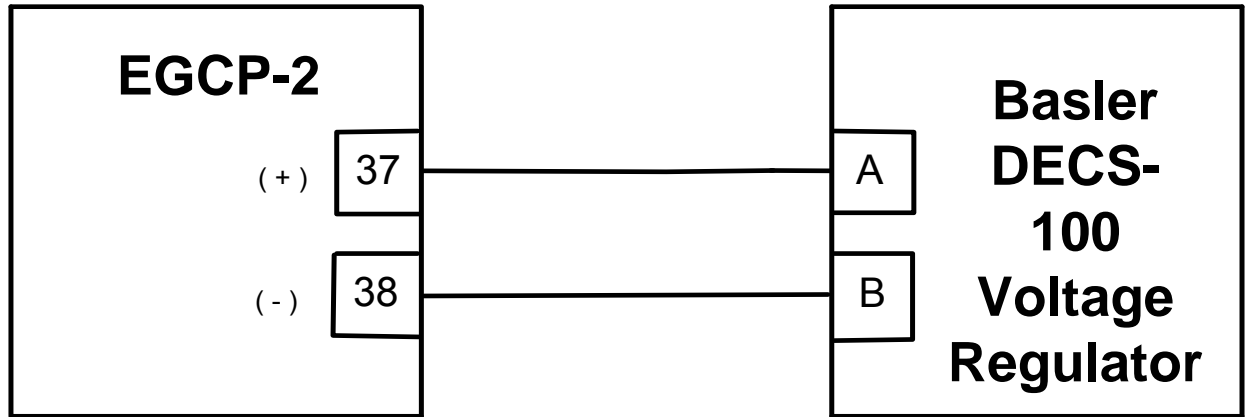
**EGCP-2 settings:****Configuration Menu**

Voltage Bias Type: +/- 1 VDC

Calibration Menu

Volts Bias Offset: 0%

Shutdown & Alarms MenuGen Volt Hi Lmt: * 10% above
ratedGen Volt Lo Lmt: * 10% below
rated**Reactive Load Control Menu**

VAR/ PF Gain: 1.0

Volts Ramp Time: 100

VAR/ PF Sharing Gain: 0.2

VAR/ PF Stability: 2.0

PF Deadband: 0.005

* - These are only
suggested values**Voltage Regulator settings:**

Droop - set for 2 to 5 %

Set droop the same on all regulators

The EGCP-2 is connecting into the
Accessory Voltage Input. The effect of a 1
volt change will be 10% of the voltage
setting.

Adjustment Procedure

1. Start the generator with the EGCP-2 NOT connected. Set DECS for rated voltage
2. Connect the EGCP-2 as shown
3. Start Generator
4. Adjust the Volts Bias Offset for rated voltage.
5. Press ENTER to save this value
6. Close the Voltage Raise discrete input (4) and verify the EGCP2 moves the generator voltage in the increase direction.
7. Close the Voltage Lower discrete input (5) to verify the EGCP-2 drives the generator voltage in the decrease direction.
8. The Reactive Load Control Menu items may need adjusted for stable Power Factor control.

Basler DECS 200

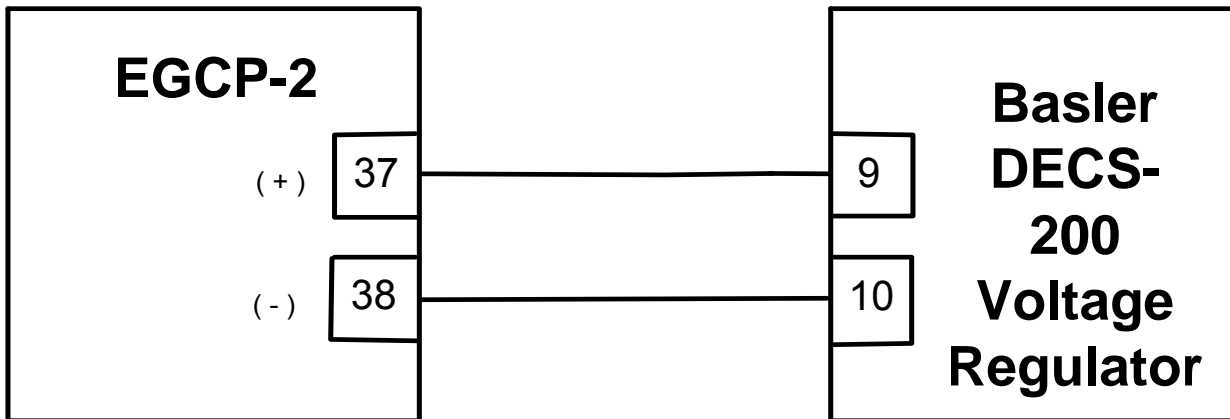
**EGCP-2 settings:****Configuration Menu**

Voltage Bias Type: +/- 1 VDC

Calibration Menu

Volts Bias Offset: 0%

Shutdown & Alarms MenuGen Volt Hi Lmt: * 10% above
ratedGen Volt Lo Lmt: * 10% below
rated**Reactive Load Control Menu**

VAR/ PF Gain: 1.0

Volts Ramp Time: 100

VAR/ PF Sharing Gain: 0.2

VAR/ PF Stability: 2.0

PF Deadband: 0.005

* - These are only
suggested values**Voltage Regulator settings:**

Droop - set for 2 to 5 %

Set droop the same on all regulators

The EGCP-2 is connecting into the
Accessory Voltage Input. The effect of a 1
VDC change is determined by theAccessory Gain setting in the DECS-200.Set this number to 10. This will provide a
10% change to the Rated voltage for every
volt change on this input.**Adjustment Procedure**

1. Start the generator with the EGCP-2 NOT connected. Set DECS for rated voltage
2. Connect the EGCP-2 as shown
3. Start Generator
4. Adjust the Volts Bias Offset for rated voltage.
5. Press ENTER to save this value
6. Close the Voltage Raise discrete input (4) and verify the EGCP2 moves the generator voltage in the increase direction.
7. Close the Voltage Lower discrete input (5) to verify the EGCP-2 drives the generator voltage in the decrease direction.
8. The Reactive Load Control Menu items may need adjusted for stable Power Factor control.

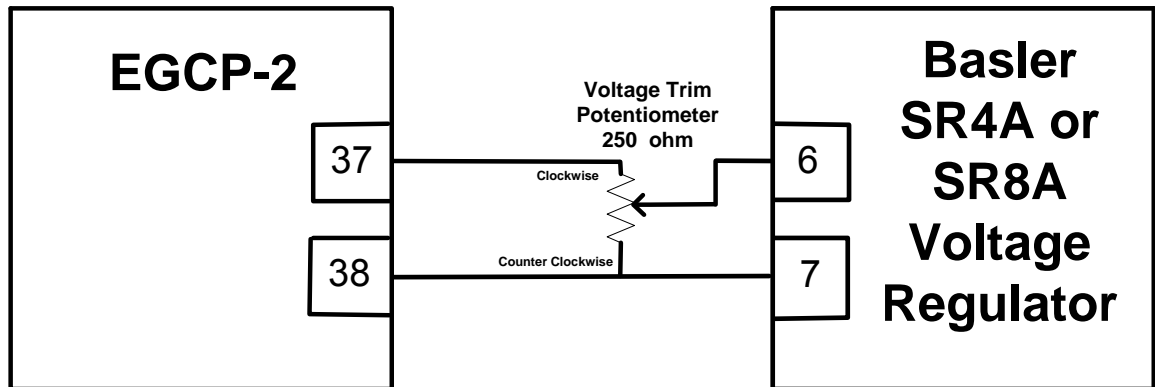
Basler SR4A or SR8A**EGCP-2 settings:****Configuration Menu**

Voltage Bias Type: +/- 3 VDC

Calibration Menu

Volts Bias Offset: -45%

Shutdown & Alarms MenuGen Volt Hi Lmt: * 10 above
ratedGen Volt Lo Lmt: * 10 below
rated**Reactive Load Control Menu**

VAR/ PF Gain: 1.0

Volts Ramp Time: 200

VAR/ PF Sharing Gain: 0.2

VAR/ PF Stability: 2.0

PF Deadband: 0.005

* - These are only
suggested values**Voltage Regulator settings:**

Droop - set for 2 to 5 %

In a multiple generator system, set
droop the same on all regulators**Voltage Trim Potentiometer:**

250 ohm, 10 Turn, 1 Watt

Set to Mid-Range

Potentiometer value can be a value
of 150 to 250 ohms.**Adjustment Procedure****Start Generator**

1. Set the Voltage Adjust potentiometer on the SR4A or SR8A for Rated Voltage of generator set. (course adjustment)
2. Use the Voltage Trim potentiometer to fine tune the Rated Voltage. This is the potentiometer shown above.
3. The Voltage Trim potentiometer is now calibrated and should not be adjusted anymore.
4. Close the Voltage Raise discrete input (4) and verify the EGCP-2 can move the generator voltage in the increase direction.
5. Close the Voltage Lower discrete input (5) and verify the EGCP-2 can move the generator voltage in the decrease direction.
6. The Reactive Load Menu items may need adjusted for stable Power Factor control.

Basler SSR

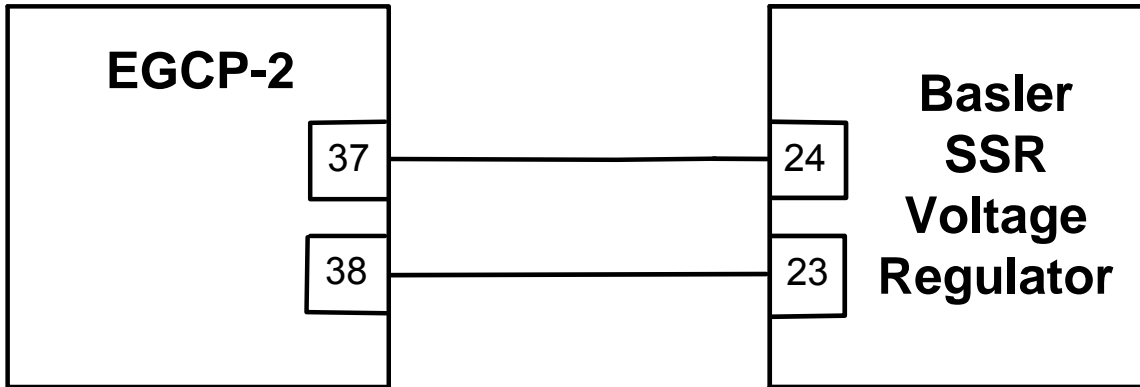

EGCP-2 settings:

Configuration Menu

Volts Bias Type: +/- 1 VDC

Calibration Menu

Volts Bias Offset: 0%

Shutdown & Alarms Menu

Gen Volt Hi Lmt: * 10% above
rated

Gen Volt Lo Lmt: * 10% below
rated

Reactive Load Control Menu

VAR/ PF Gain: 1.0

Volts Ramp Time: 100

VAR/ PF Sharing Gain: 0.2

VAR/ PF Stability: 2.0

PF Deadband: 0.005

* - These are only
suggested values

Voltage Regulator settings:

Drop - set for 2 to 5 %

In a multiple generator system, set
droop the same on all regulators

Adjustment Procedure

1. Start the generator with the EGCP-2 NOT connected.
Set SSR for rated voltage
2. Connect the EGCP-2 as shown
3. Start Generator
4. Adjust the Volts Bias Offset for rated voltage.
5. Press ENTER to save this value
6. Close the Voltage Raise discrete input (4) and verify the EGCP2 can move the generator voltage in the increase direction.
7. Close the Voltage Lower discrete input (5) to verify the EGCP-2 can drive the generator voltage in the decrease direction.
8. The Reactive Load Control Menu items may need adjusted for stable Power Factor control.

Caterpillar CDVR

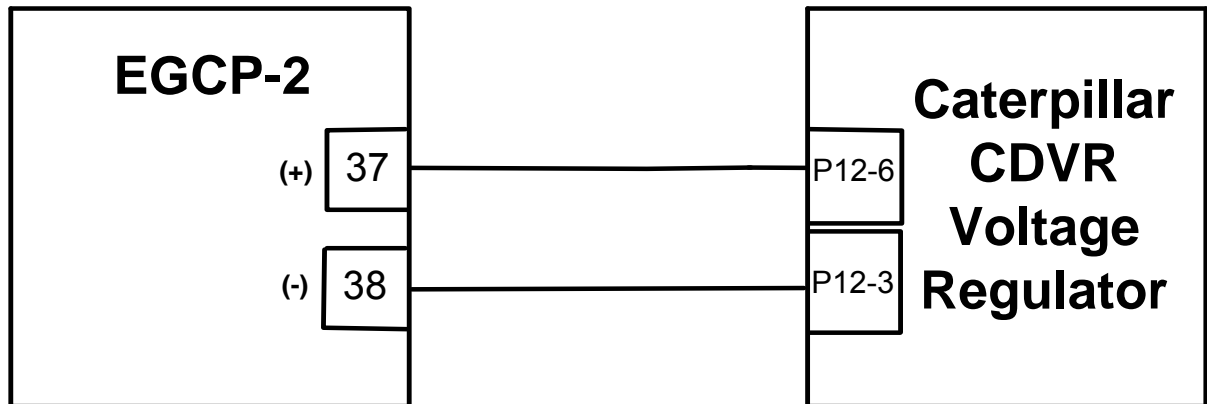

EGCP-2 settings:

Configuration Menu

Voltage Bias Type: +/- 9 VDC

Calibration Menu

Volts Bias Offset: 0%

Shutdown & Alarms Menu

Gen Volt Hi Lmt: * 10% above
rated

Gen Volt Lo Lmt: * 10% below
rated

Reactive Load Control Menu

VAR/ PF Gain: 1.0

Volts Ramp Time: 60

VAR/ PF Sharing Gain: 0.2

VAR/ PF Stability: 2.0

PF Deadband: 0.005

* - These are only
suggested values

Voltage Regulator settings:

Droop - set for 2 to 5 %

In a multiple generator system, set
droop the same on all regulators

CDVR Control Input:

For every 1 VDC change the CDVR
will change the generator voltage 1%
Maximum change = 9%

Adjustment Procedure

1. Start the generator with the EGCP-2 NOT connected.
Set CDVR for rated voltage
2. Connect the EGCP-2 as shown
3. Start Generator
4. Adjust the Volts Bias Offset for rated voltage.
5. Press ENTER to save this value
6. Close the Voltage Raise discrete input (4) and verify the EGCP2 can move the generator voltage in the increase direction.
7. Close the Voltage Lower discrete input (5) to verify the EGCP-2 can drive the generator voltage in the decrease direction.
8. The Reactive Load Control Menu items may need adjusted for stable Power Factor control.

Caterpillar Digital Voltage Regulator

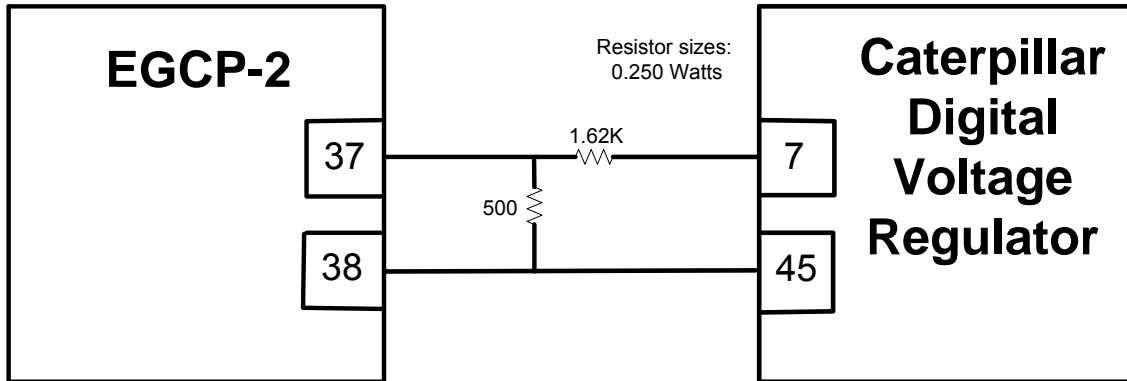

EGCP-2 Settings:

Configuration Menu
Voltage Bias Type: +/- 3 VDC

Calibration Menu
Volts Bias Offset: 0%

Shutdown & Alarms Menu
Gen Volt Hi Lmt: * 10% above rated
Gen Volt Lo Lmt: * 10% below rated

Reactive Load Control menu
VAR/ PF Gain: 0.5
Volts Ramp Time: 200 Sec
VAR/ PF Sharing Gain: 0.1
VAR/ PF Stability: 2.0
PF Deadband: 0.005

* - these are only suggested settings.

Voltage Regulator settings:

Droop - set for 2 to 5 %
In a multiple generator system, set droop the same on all regulators

External Resistors:

1.62 K ohm
500 ohm
Resistor Wattage - 0.250

Adjustment Procedure:

1. Measure across terminals 37(+) and 38 (-) prior to connecting to DVR = 0.0 volts
2. Connect to DVR, measure across terminals 7 and 45 = 2 volts
3. The Cat DVR uses 2 volts as the zero bias point, taking a 0 - 4 volt input to change the voltage reference +/- 10%.
4. Start Generator
5. Adjust Volts Bias Offset for Rated Voltage
6. Press ENTER to save this value
7. The items in the Reactive Load menu may need adjusted for stable Power Factor control.

Caterpillar VR3

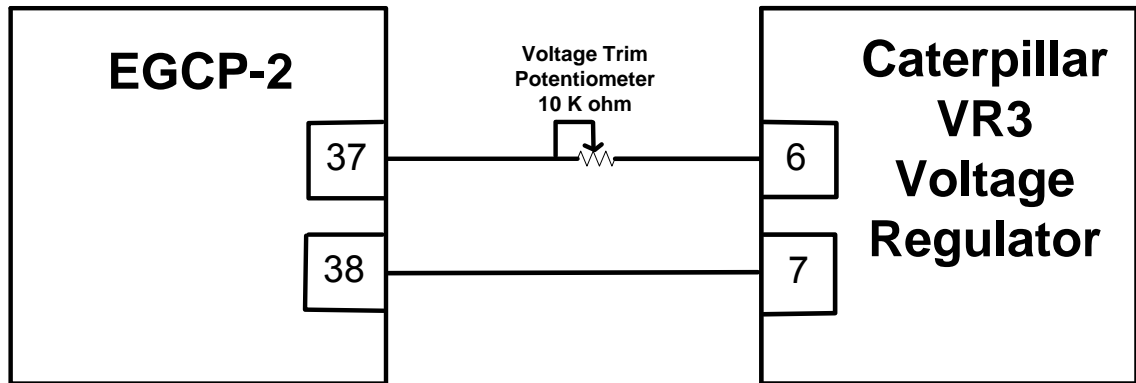

EGCP-2 Settings:

Configuration Menu

Voltage Bias Type: +/- 1 VDC

Calibration Menu

Volts Bias Offset: -1%

Shutdown & Alarms Menu

Gen Volt Hi Lmt: * 10% above rated

Gen Volt Lo Lmt: * 10% below rated

Reactive Load Control menu

VAR/ PF Gain: 0.3

Volts Ramp Time: 200 Sec

VAR/ PF Sharing Gain: 0.1

VAR/ PF Stability: 4.0

PF Deadband: 0.005

* - these are only suggested settings.

Voltage Regulator settings:

Droop - set for 2 to 5 %

In a multiple generator system, set droop the same on all regulators

Voltage Trim Potentiometer:

10 K ohm, 10 turn, 1 Watt

Set to Mid-Range

A 5 K ohm, 0.25 Watt resistor may be used in place of the pot

Adjustment Procedure:

1. Start Generator
2. Adjust Volts Bias Offset for Rated Voltage
3. Press ENTER to save this value
4. The items in the Reactive Load menu may need adjusted for stable Power Factor control.

Caterpillar VR6

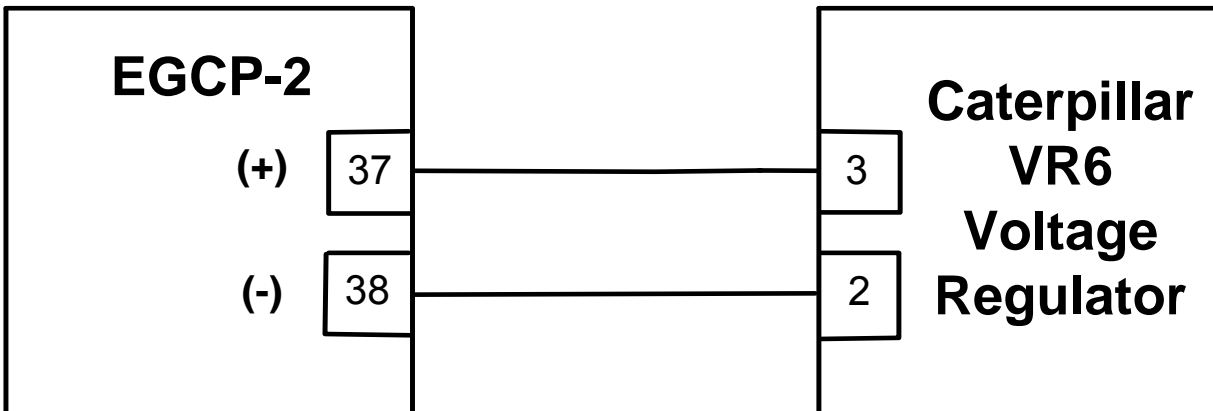
**EGCP-2 settings:****Configuration Menu**

Voltage Bias Type: +/- 1 VDC

Calibration Menu

Volts Bias Offset: 0%

Shutdown & Alarms MenuGen Volt Hi Lmt: * 10% above
ratedGen Volt Lo Lmt: * 10% below
rated**Reactive Load Control Menu**

VAR/ PF Gain: 1.0

Volts Ramp Time: 100

VAR/ PF Sharing Gain: 0.2

VAR/ PF Stability: 2.0

PF Deadband: 0.005

* - These are only
suggested values**Voltage Regulator settings:**

Droop - set for 2 to 5 %

In a multiple generator system, set
droop the same on all regulatorsTerminals 2 and 3 will provide
a 10% per volt range**Adjustment Procedure**

1. Start the generator with the EGCP-2 NOT connected and set for rated voltage.
**Terminals 2 and 3 on the AVR must be jumpered when doing this.
2. Connect the EGCP-2 as shown.
3. Start Generator
4. Adjust the Volts Bias Offset for rated voltage.
5. Press ENTER to save this value
6. Close the Voltage Raise discrete input (4) and verify the EGCP2 can move the generator voltage in the increase direction.
7. Close the Voltage Lower discrete input (5) to verify the EGCP-2 can drive the generator voltage in the decrease direction.

KATO KCR360 or 760

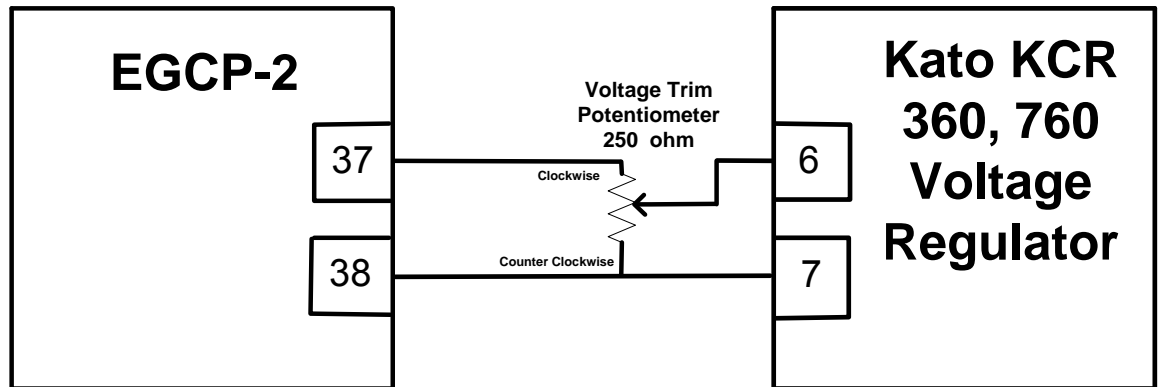
**EGCP-2 settings:****Configuration Menu**

Voltage Bias Type: +/- 3 VDC

Calibration Menu

Volts Bias Offset: -45%

Shutdown & Alarms MenuGen Volt Hi Lmt: * 10 above
ratedGen Volt Lo Lmt: * 10 below
rated**Reactive Load Control Menu**

VAR/ PF Gain: 1.0

Volts Ramp Time: 200

VAR/ PF Sharing Gain: 0.2

VAR/ PF Stability: 2.0

PF Deadband: 0.005

* - These are only
suggested values**Voltage Regulator settings:**

Droop - set for 2 to 5 %

In a multiple generator system, set
droop the same on all regulators**Voltage Trim Potentiometer:**

250 ohm, 10 Turn, 1 Watt

Set to Mid-Range

Potentiometer can be a value of
150 to 250 ohms.**Adjustment Procedure****Start Generator**

1. Set the Voltage Adjust potentiometer on the Kato for Rated Voltage of generator set. (course adjustment)
2. Use the Voltage Trim potentiometer to fine tune the Rated Voltage. This is the potentiometer shown above.
3. The Voltage Trim potentiometer is now calibrated and should not be adjusted anymore.
4. The Reactive Load Menu items may need adjusted for stable Power Factor control.

KATO K65-12B or K125-10B

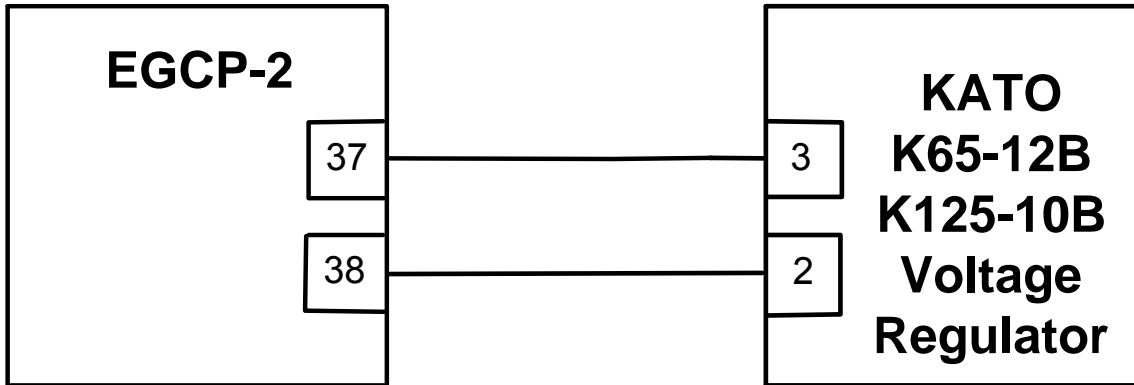
**EGCP-2 settings:**

Configuration Menu
Voltage Bias Type: +/- 1 VDC

Calibration Menu
Volts Bias Offset: 0%

Shutdown & Alarms Menu
Gen Volt Hi Lmt: * 10% above rated
Gen Volt Lo Lmt: * 10% below rated

Reactive Load Control Menu
VAR/ PF Gain: 1.0
Volts Ramp Time: 100
VAR/ PF Sharing Gain: 0.2
VAR/ PF Stability: 2.0
PF Deadband: 0.005

* - These are only suggested values

Voltage Regulator settings:

Drop - set for 2 to 5 %
In a multiple generator system, set droop the same on all regulators

Terminals 2 and 3 will provide a 10% per volt range

Adjustment Procedure

1. Start the generator with the EGCP-2 NOT connected and set for rated voltage. Terminals 2 and 3 on the AVR must be jumpered when doing this.
2. Connect the EGCP-2 as shown.
3. Start Generator
4. Adjust the Volts Bias Offset for rated voltage.
5. Press ENTER to save this value
6. Close the Voltage Raise discrete input (4) and verify the EGCP2 can move the generator voltage in the increase direction.
7. Close the Voltage Lower discrete input (5) to verify the EGCP-2 can drive the generator voltage in the decrease direction.

Leroy Somer R438, R448, or R449

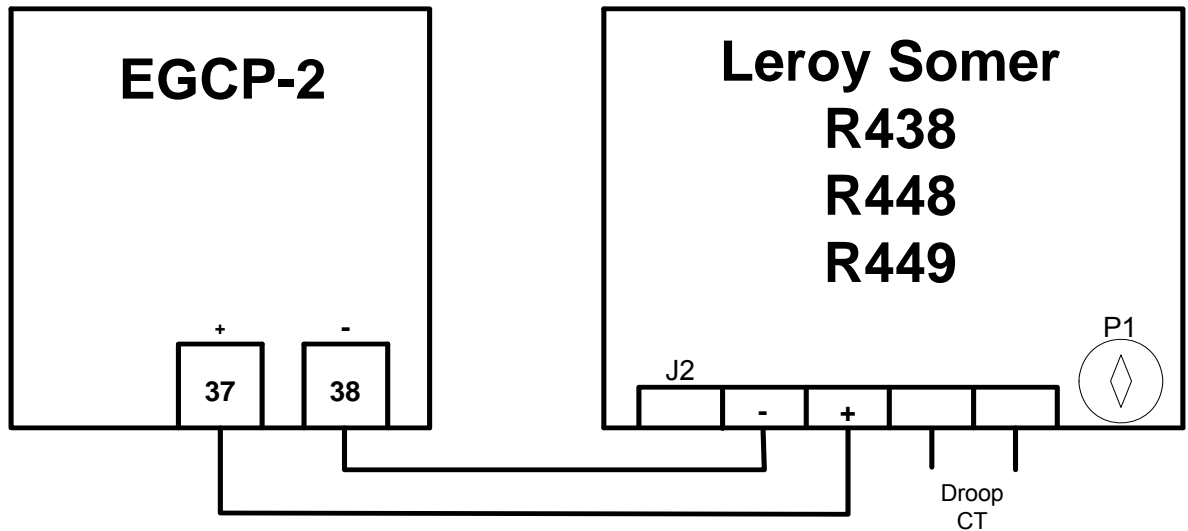
**EGCP-2 settings:****Configuration Menu**Voltage Bias Type: **+/- 1 VDC****Calibration Menu**Volts Bias Offset: **0%****Shutdown & Alarms Menu**Gen Volt Hi Lmt: *** 10% above
rated**Gen Volt Lo Lmt: *** 10% below
rated****Reactive Load Control Menu**VAR/ PF Gain: **1.0**Volts Ramp Time: **100**VAR/ PF Sharing Gain: **0.2**VAR/ PF Stability: **2.0**PF Deadband: **0.005**

* - These are only
suggested values

Voltage Regulator settings:Droop - set for **2 to 5 %**In a multiple generator system, set
droop the same on all regulatorsA +/- 1 VDC signal will provide
a +/- 10% voltage range.**Adjustment Procedure**

1. Start the generator with the EGCP-2 NOT connected.
Set SSR for rated voltage
2. Connect the EGCP-2 as shown
3. Start Generator
4. Adjust the Volts Bias Offset for rated voltage.
5. Press ENTER to save this value
6. Close the Voltage Raise discrete input (4) and verify the EGCP2 can move the generator voltage in the increase direction.
7. Close the Voltage Lower discrete input (5) to verify the EGCP-2 can drive the generator voltage in the decrease direction.
8. The Reactive Load Control Menu items may need adjusted for stable Power Factor control.

Leroy Somer R600

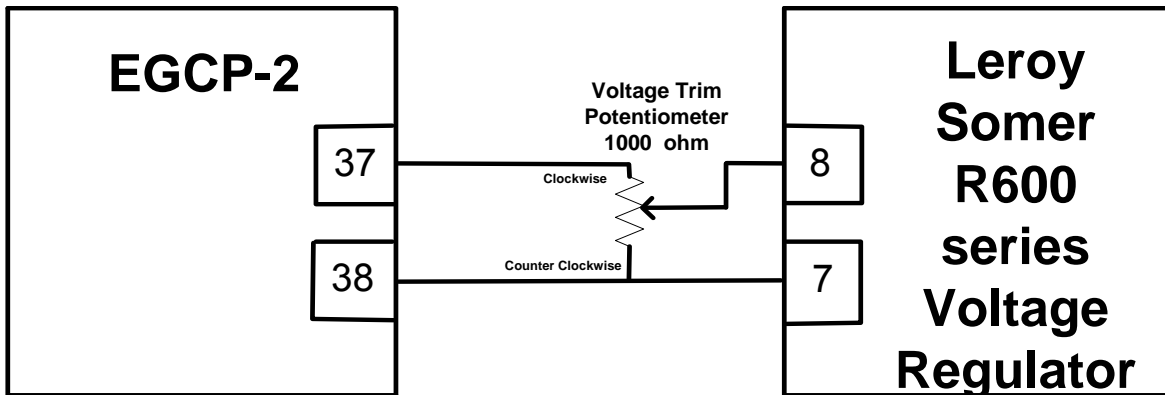
**EGCP-2 settings:**

Configuration Menu
Voltage Bias Type: +/- 3 VDC

Calibration Menu
Volts Bias Offset: 33%

Shutdown & Alarms Menu
Gen Volt Hi Lmt: * 10 above
rated
Gen Volt Lo Lmt: * 10 below
rated

Reactive Load Control Menu
VAR/ PF Gain: 1.0
Volts Ramp Time: 200
VAR/ PF Sharing Gain: 0.2
VAR/ PF Stability: 2.0
PF Deadband: 0.005

* - These are only
suggested values

Voltage Regulator settings:

Droop - set for 2 to 5 %
In a multiple generator system, set
droop the same on all regulators

Voltage Trim Potentiometer:

1000 ohm, 10 Turn, 1 Watt

Set to Mid-Range

Adjustment Procedure**Start Generator**

1. Set the R600 series voltage regulator to control at rated voltage with no potentiometer connected to terminal 7 and 8.
2. Stop engine and connect Voltage Trim Pot as shown in picture.
3. Start gen set, adjust the Voltage Trim potentiometer for Rated Voltage. This is the potentiometer shown above.
3. The Voltage Trim potentiometer is now calibrated and should not be adjusted anymore.
4. Close the Voltage Raise discrete input (4) and verify the EGCP-2 can move the generator voltage in the increase direction.
5. Close the Voltage Lower discrete input (5) and verify the EGCP-2 can move the generator voltage in the decrease direction.
6. The Reactive Load Menu items may need adjusted for stable Power Factor control.

Leroy Somer R610

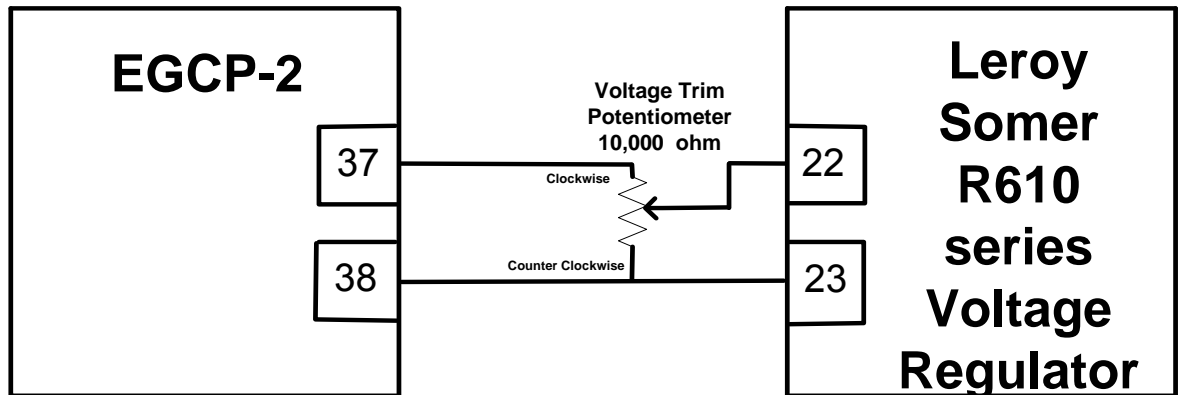
**EGCP-2 settings:**

Configuration Menu
Voltage Bias Type: +/- 3 VDC

Calibration Menu
Volts Bias Offset: 33%

Shutdown & Alarms Menu
Gen Volt Hi Lmt: * 10 above
rated
Gen Volt Lo Lmt: * 10 below
rated

Reactive Load Control Menu
VAR/ PF Gain: 1.0
Volts Ramp Time: 200
VAR/ PF Sharing Gain: 0.2
VAR/ PF Stability: 2.0
PF Deadband: 0.005

* - These are only
suggested values

Voltage Regulator settings:

Droop - set for 2 to 5 %
In a multiple generator system, set
droop the same on all regulators

Voltage Trim Potentiometer:

10,000 ohm, 10 Turn, 1 Watt

Set to Mid-Range

Adjustment Procedure**Start Generator**

1. Set the R610 series voltage regulator to control at rated voltage with no potentiometer connected to terminal 22 and 23.
2. Stop engine and connect Voltage Trim Pot as shown in picture.
3. Start gen set, adjust the Voltage Trim potentiometer for Rated Voltage. This is the potentiometer shown above.
3. The Voltage Trim potentiometer is now calibrated and should not be adjusted anymore.
4. Close the Voltage Raise discrete input (4) and verify the EGCP-2 can move the generator voltage in the increase direction.
5. Close the Voltage Lower discrete input (5) and verify the EGCP-2 can move the generator voltage in the decrease direction.
6. The Reactive Load Menu items may need adjusted for stable Power Factor control.

Marathon PM 100/200

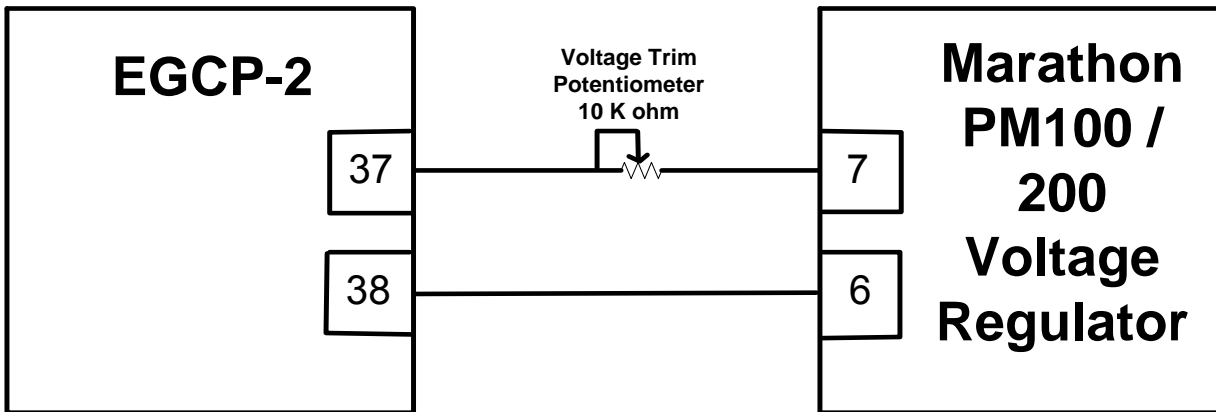
**EGCP-2 Settings:**

Configuration Menu

Voltage Bias Type: +/- 1 VDC

Calibration Menu

Volts Bias Offset: 0%

Shutdown & Alarms Menu

Gen Volt Hi Lmt: * 10% above rated

Gen Volt Lo Lmt: * 10% below rated

Reactive Load Control menu

VAR/ PF Gain: 0.3

Volts Ramp Time: 200 Sec

VAR/ PF Sharing Gain: 0.1

VAR/ PF Stability: 4.0

PF Deadband: 0.005

* - these are only suggested settings.

Voltage Regulator settings:

Droop - set for 2 to 5 %

In a multiple generator system, set droop the same on all regulators

Voltage Trim Potentiometer:

10 K ohm, 10 turn, 1 Watt

Set to Mid-Range

**A 5 K ohm, 0.25 Watt resistor may be used in place of the pot

Adjustment Procedure:

1. Start Generator
2. Adjust Volts Bias Offset for Rated Voltage
3. Press ENTER to save this value
4. The items in the Reactive Load menu may need adjusted for stable Power Factor control.

Marathon 2000E

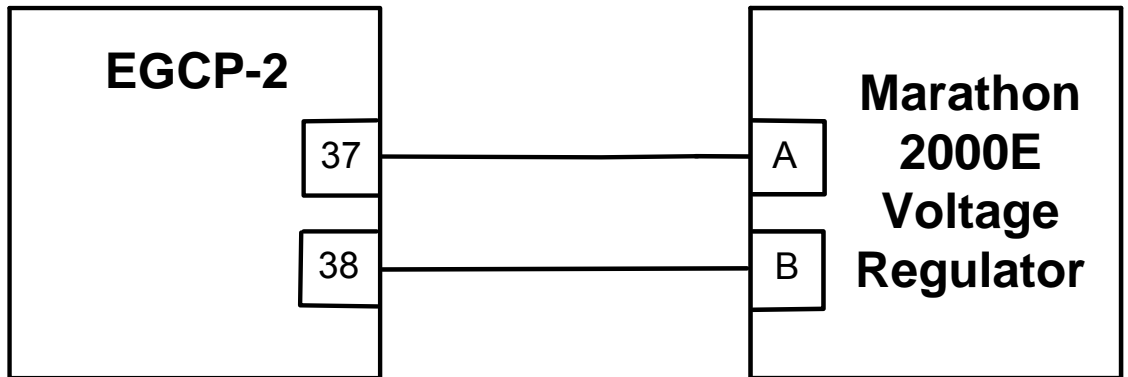

EGCP-2 settings:

Configuration Menu

Voltage Bias Type: +/- 1 VDC

Calibration Menu

Volts Bias Offset: 0%

Shutdown & Alarms Menu

Gen Volt Hi Lmt: * 10% above
rated

Gen Volt Lo Lmt: * 10% below
rated

Reactive Load Control Menu

VAR/ PF Gain: 1.0

Volts Ramp Time: 100

VAR/ PF Sharing Gain: 0.2

VAR/ PF Stability: 2.0

PF Deadband: 0.005

* - These are only
suggested values

Voltage Regulator settings:

Droop - set for 2 to 5 %

In a multiple generator system, set droop the same on all regulators

Terminals A and B will

provide a 10% per volt range

If using a Marathon 2000EC,

the VAR/PF control must be disabled in the AVR or the EGCP-2.

AVR - software configurable or jumpering terminals 52J and 52K.

EGCP-2 - software configurable

Adjustment Procedure

1. Start the generator with the EGCP-2 NOT connected and set for rated voltage.
2. Connect the EGCP-2 as shown.
3. Start Generator
4. Adjust the Volts Bias Offset for rated voltage.
5. Press ENTER to save this value
6. Close the Voltage Raise discrete input (4) and verify the EGCP2 can move the generator voltage in the increase direction.
7. Close the Voltage Lower discrete input (5) to verify the EGCP-2 can drive the generator voltage in the decrease direction.

Mecc Alte UVR

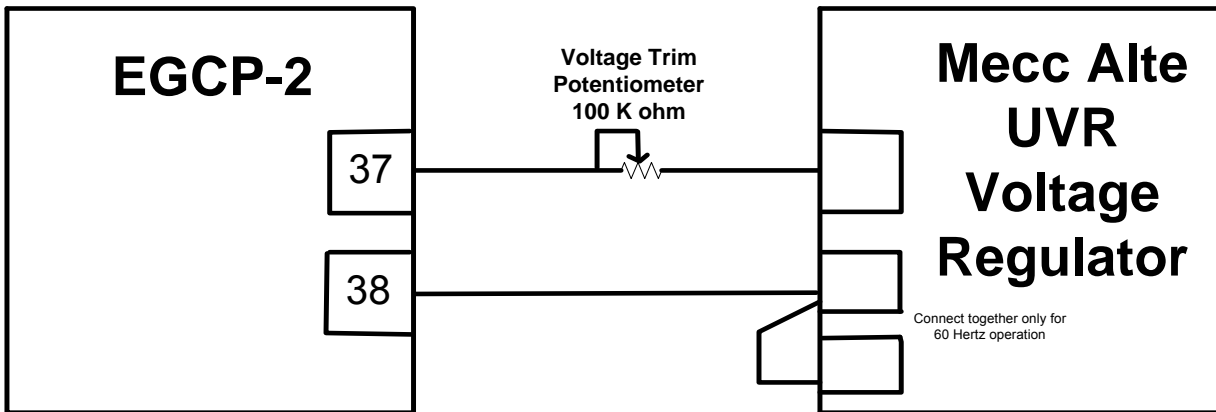

EGCP-2 Settings:

Configuration Menu

Voltage Bias Type: +/- 3 VDC

Calibration Menu

Volts Bias Offset: 0%

Shutdown & Alarms Menu

Gen Volt Hi Lmt: * 10% above rated

Gen Volt Lo Lmt: * 10% below rated

Reactive Load Control menu

VAR/ PF Gain: 1.0

Volts Ramp Time: 100 Sec

VAR/ PF Sharing Gain: 0.1

VAR/ PF Stability: 2.0

PF Deadband: 0.005

* - these are only suggested settings.

Voltage Regulator settings:

The Mecc-Alte UVR has no terminal numbers for the remote voltage control potentiometer. The connection is placed next to the 50/60 hertz selection jumper.

Voltage Trim Potentiometer:

100 K ohm, 10 turn, 1 Watt

Set to Mid-Range

Adjustment Procedure:

1. Start Generator
2. Adjust Volts Bias Offset for Rated Voltage
3. Press ENTER to save this value
4. The items in the Reactive Load menu may need adjusted for stable Power Factor control.

Newage MA325

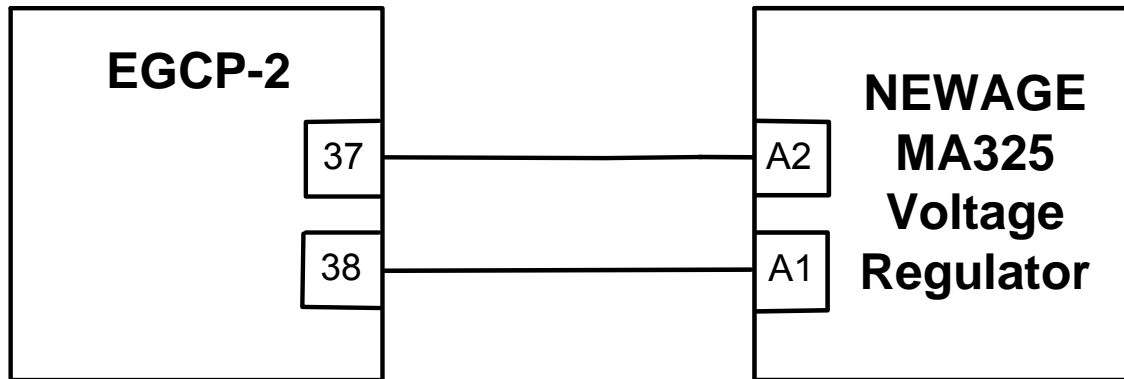
**EGCP-2 settings:**

Configuration Menu

Voltage Bias Type: +/- 3 VDC

Calibration Menu

Volts Bias Offset: 0%

Shutdown & Alarms Menu

Gen Volt Hi Lmt: * 10% above
rated

Gen Volt Lo Lmt: * 10% below
rated

Reactive Load Control Menu

VAR/ PF Gain: 1.0

Volts Ramp Time: 100

VAR/ PF Sharing Gain: 0.2

VAR/ PF Stability: 2.0

PF Deadband: 0.005

* - These are only
suggested values

Voltage Regulator settings:

Droop - set for 2 to 5 %

In a multiple generator system, set
droop the same on all regulators

TRIM

Set TRIM pot fully Clockwise. This
will provide a 5% per volt change
on the accessory input.

Adjustment Procedure

1. Start the generator with the EGCP-2 NOT connected. Set the MA325 for rated voltage
2. Connect the EGCP-2 as shown
3. Start Generator
4. Adjust the Volts Bias Offset for rated voltage.
5. Press ENTER to save this value
6. Close the Voltage Raise discrete input (4) and verify the EGCP2 can move the generator voltage in the increase direction.
7. Close the Voltage Lower discrete input (5) to verify the EGCP-2 can drive the generator voltage in the decrease direction.

Newage MA327

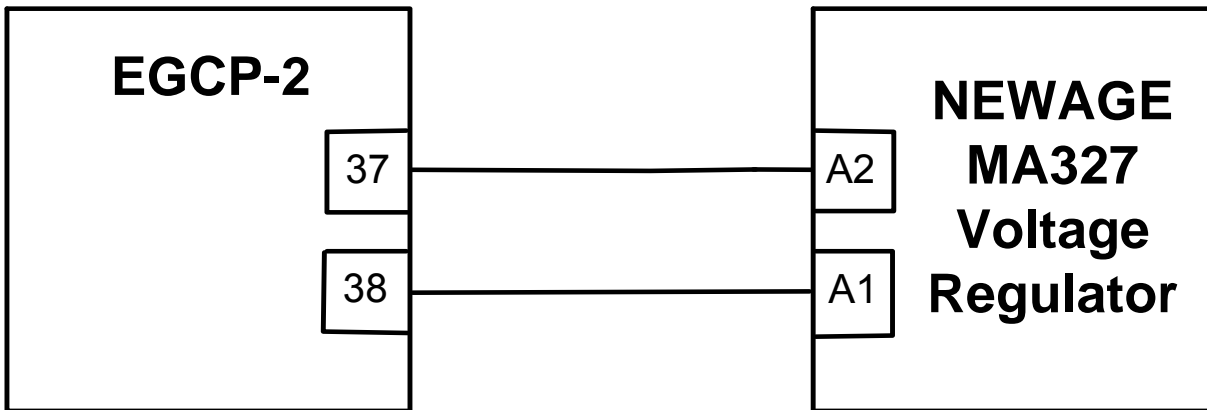
**EGCP-2 settings:****Configuration Menu**

Voltage Bias Type: +/- 3 VDC

Calibration Menu

Volts Bias Offset: 0%

Shutdown & Alarms MenuGen Volt Hi Lmt: * 10% above
ratedGen Volt Lo Lmt: * 10% below
rated**Reactive Load Control Menu**

VAR/ PF Gain: 1.0

Volts Ramp Time: 100

VAR/ PF Sharing Gain: 0.2

VAR/ PF Stability: 2.0

PF Deadband: 0.005

* - These are only
suggested values**Voltage Regulator settings:**

Droop - set for 2 to 5 %

In a multiple generator system, set
droop the same on all regulators**TRIM**Set TRIM pot fully Clockwise. This
will provide a 5% per volt change
on the accessory input.**Adjustment Procedure**

1. Start the generator with the EGCP-2 NOT connected. Set the MA325 for rated voltage
2. Connect the EGCP-2 as shown
3. Start Generator
4. Adjust the Volts Bias Offset for rated voltage.
5. Press ENTER to save this value
6. Close the Voltage Raise discrete input (4) and verify the EGCP2 can move the generator voltage in the increase direction.
7. Close the Voltage Lower discrete input (5) to verify the EGCP-2 can drive the generator voltage in the decrease direction.

Newage MX321/341

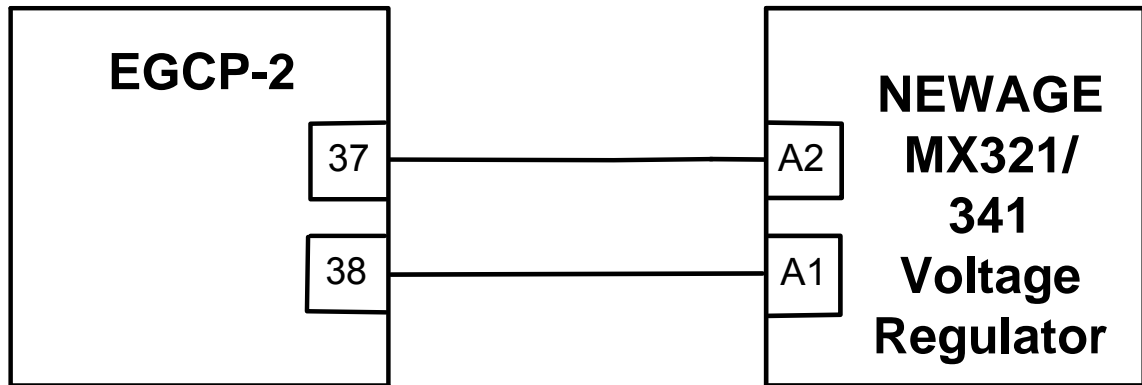
**EGCP-2 settings:**

Configuration Menu

Voltage Bias Type: +/- 3 VDC

Calibration Menu

Volts Bias Offset: 0%

Shutdown & Alarms Menu

Gen Volt Hi Lmt: * 10% above
ratedGen Volt Lo Lmt: * 10% below
rated

Reactive Load Control Menu

VAR/ PF Gain: 1.0

Volts Ramp Time: 100

VAR/ PF Sharing Gain: 0.2

VAR/ PF Stability: 2.0

PF Deadband: 0.005

* - These are only
suggested values**Voltage Regulator settings:**

Droop - set for 2 to 5 %

In a multiple generator system, set
droop the same on all regulators
TRIMSet TRIM pot fully Clockwise. This
will provide a 5% per volt change
on the accessory input.**Adjustment Procedure**

1. Start the generator with the EGCP-2 NOT connected. Set the 321 or 341 for rated voltage
2. Connect the EGCP-2 as shown
3. Start Generator
4. Adjust the Volts Bias Offset for rated voltage.
5. Press ENTER to save this value
6. Close the Voltage Raise discrete input (4) and verify the EGCP2 can move the generator voltage in the increase direction.
7. Close the Voltage Lower discrete input (5) to verify the EGCP-2 can drive the generator voltage in the decrease direction.

Appendix D.

EGCP-2 Set Point Worksheet

Configuration Menu

| Item: | Range: | Default: | As Set Value: | Note: |
|---------------------|--|------------------|---------------|--|
| SECURITY CODE | Min: 0 Max: 9999 | **** | | See Security Access |
| NETWORK ADDRESS | Min: 1 Max: 8 | 1 | | Only accessible if configured for multiple units |
| NETWORK PRIORITY | Min: 1 Max: 8 | 1 | | Only accessible if configured for multiple units |
| NUMBER OF POLES | Min: 2 Max: 18 | 4 | | |
| NUMBER OF TEETH | Min: 16 Max: 500 | 60 | | |
| SYSTEM FREQUENCY | Min: 50 Max: 60 | 60 Hz | | |
| RATED SPEED | Min: 100 Max: 5000 | 1800 rpm | | |
| RATED KW | Min: 1 Max: 30000 | 0 kW | | |
| RATED kVA | Min: 1 Max: 30000 | 0 kVA | | |
| RATED kVAR | Min: 1 Max: 30000 | 0 kVAR | | |
| CT RATIO | Min: 5:5 Max: 30000:5 | 5:5 | | |
| PT RATIO | Min: 1.0:1 Max: 1000.0:1 | 1.0:1 | | |
| VOLTAGE INPUT | Wye line-neutral Delta line-line | Wye line-neutral | | |
| VOLTAGE REF | Min: 1 Max: 30000 | 220 Volts | | |
| DISPLAY UNITS | American Metric | American | | |
| SET DATE | MM-DD-YY | 6-15-2001 | | |
| SET TIME | HH:MM | 12:00 | | 24 Hr. CLOCK |
| START SEQUENCING | Enable Disable | Enable | | |
| RELAY #12 FUNCTION | kVA Load Switch Idle / Rated Switch | kVA Load Switch | | |
| SPEED BIAS TYPE | ±3 Vdc (WGC) 0.5 to 4.5 Vdc (DDEC) 500 Hz PWM (ADEM) | ±3 Vdc | | |
| VOLTAGE BIAS TYPE | ±1 Vdc ±3 Vdc ±9 Vdc | ±1 Vdc | | |
| CKT BREAKER CONTROL | Breaker Contactor | Breaker | | |
| OPERATING MODE | No Parallel Mains Parallel | No Parallel | | |
| NUMBER OF UNITS | Single Multiple | Single | | |

Shutdown and Alarms Menu

| Item: | Range: | Default: | As Set Value: | Note: |
|---------------------|--|---------------|---------------|---------|
| VOLTAGE RNG ALM | Audible Alarm Visual Alarm Warning Disabled | Warning | | |
| GEN VOLT HI LMT | Min: 50 Max: 30000 | 250.0 Volts | | |
| GEN VOLT HI ALM | Disabled Warning Visual Alarm Audible Alarm Soft Shutdown Hard Shutdown | Warning | | |
| GEN VOLT LO LMT | Min: 50 Max: 30000 | 200.0 Volts | | |
| GEN VOLT LO ALM | Disabled Warning Visual Alarm Audible Alarm Soft Shutdown Hard Shutdown | Warning | | |
| VOLTAGE ALM DLY | Min: 0.1 Max: 30.0 | 5.0 s | | |
| GEN FREQ HI LMT | Min: 40 Max: 75 | 65 Hz | | |
| GEN FREQ HI ALM | Disabled Warning Visual Alarm Audible Alarm Soft Shutdown Hard Shutdown | Warning | | |
| GEN FREQ LO LMT | Min: 40 Max: 75 | 55 Hz | | |
| GEN FREQ LO ALM | Disabled Warning Visual Alarm Audible Alarm Soft Shutdown Hard Shutdown | Warning | | |
| SPD FREQ MISMTCH | Disabled Warning Visual Alarm Audible Alarm Soft Shutdown Hard Shutdown | Disabled | | |
| OVERCURRENT LVL | Min: 5.0 Max: 30000.0 | 30 A | | |
| OVERCURRENT DLY | Min: 0.1 Max: 20.0 | 1.0 s | | |
| OVERCURRENT ALM | Disabled Warning Visual Alarm Audible Alarm Soft Shutdown Hard Shutdown | Soft Shutdown | | |
| REVERSE PWR | Min: -50.0 Max: -1.0 | -10.0% | | Instant |
| REV PWR DELAY | Min: 0.1 Max: 20.0 | 5.0 s | | |
| MIN REVERSE PWR | Min: -50.0 Max: -1.0 | -5.0% | | |

| Item: | Range: | Default: | As Set Value: | Note: |
|------------------------|--|---------------|---------------|------------------------------|
| REVERSE PWR ALM | Disabled Warning Visual Alarm Audible Alarm Soft Shutdown Hard Shutdown | Soft Shutdown | | |
| REVERSE kVAR LIMIT | Min: -100.0 Max: -5.0 | -50.0% | | |
| REVERSE kVAR DELAY | Min: 0.1 Max: 5.0 | 5.0 s | | |
| REVERSE kVAR ALARM | Disabled Warning Visual Alarm Audible Alarm Soft Shutdown Hard Shutdown | Warning | | |
| REMOTE FAULT1 | Disabled Warning Visual Alarm Audible Alarm Soft Shutdown Hard Shutdown | Disabled | | |
| FAULT1 TIMER | Min: 0.0 Max: 30.0 | 0.0 s | | |
| REMFLT 1 STABLE DLY | Enabled Disabled | Enabled | | Enabled = 15 Second Delay |
| REMOTE FAULT2 | Disabled Warning Visual Alarm Audible Alarm Soft Shutdown Hard Shutdown | Disabled | | |
| FAULT2 TIMER | Min: 0.0 Max: 30.0 | 0.0 s | | |
| REMFLT 2 STABLE DLY | Enabled Disabled | Enabled | | Enabled = 15 Second Delay |
| REMOTE FAULT3 | Disabled Warning Visual Alarm Audible Alarm Soft Shutdown Hard Shutdown | Hard Shutdown | | |
| FAULT3 TIMER | Min: 0.0 Max: 30.0 | 0.0 s | | |
| REMOTE FAULT4 | Disabled Warning Visual Alarm Audible Alarm Soft Shutdown Hard Shutdown | Disabled | | |
| FAULT4 TIMER | Min: 0.0 Max: 30.0 | 0.0 s | | |
| REMOTE FAULT5 | Disabled Warning Visual Alarm Audible Alarm Soft Shutdown Hard Shutdown | Disabled | | |
| FAULT5 TIMER | Min: 0.0 Max: 30.0 | 0.0 s | | |

| Item: | Range: | Default: | As Set Value: | Note: |
|---------------|--|----------|---------------|-------|
| REMOTE FAULT6 | Disabled Warning Visual Alarm Audible Alarm Soft Shutdown Hard Shutdown | Disabled | | |
| FAULT6 TIMER | Min: 0.0 Max: 30.0 | 0.0 s | | |

Engine Control Menu

| Item: | Range: | Default: | As Set Value: | Note: |
|------------------|--|---------------|---------------|-------|
| PREGLOW TIME | Min: 0 Max: 1200 | 5 s | | |
| CRANK TIME | Min: 0 Max: 240 | 10 s | | |
| CRANK CUTOFF | Min: 5 Max: 10000 | 550 rpm | | |
| CRANK DELAY | Min: 1 Max: 240 | 30 s | | |
| CRANK REPEATS | Min: 0 Max: 20 | 0 | | |
| CRANK FAIL | Warning Visual Alarm Audible Alarm | Warning | | |
| IDLE SPEED | Min: 5 Max: 30000 | 1200 rpm | | |
| IDLE TIME | Min: 1 Max: 240 | 10 s | | |
| COOLDOWN TIME | Min: 0 Max: 2400 | 120 s | | |
| COOLDOWN LIMIT | Min: 0 Max: 10000 | 20 kVA | | |
| ENGINE RUN TIME | Min: 0 Max: 32000 | 0 Hours | | |
| MW HOURS | Min: 0.0 Max: 32000.0 | 0.0 MW Hours | | |
| OVERSPEED | Min: 5.0 Max: 30000.0 | 1980 rpm | | |
| OVERSPEED ALARM | Disabled Warning Visual Alarm Audible Alarm Soft Shutdown Hard Shutdown | Hard Shutdown | | |
| BATT VOLT HI LMT | Min: 5.0 Max: 50.0 | 28.5 Volts | | |
| BATT VOLT HI ALM | Disabled Warning Visual Alarm Audible Alarm Soft Shutdown Hard Shutdown | Warning | | |
| BATT VOLT LO LMT | Min: 5.0 Max: 50.0 | 10.0 Volts | | |
| BATT VOLT LO ALM | Disabled Warning Visual Alarm Audible Alarm Soft Shutdown Hard Shutdown | Warning | | |
| HI OIL PRESS LMT | Min: 0.0 Max: 150.0 | 65 Bar or PSI | | |
| HI OIL PRESS ALM | Disabled Warning Visual Alarm Audible Alarm Soft Shutdown Hard Shutdown | Warning | | |

| Item: | Range: | Default: | As Set Value: | Note: |
|-------------------------|--|-----------------|---------------|-------|
| LO OIL PRESS PRE-LMT | Min: 0.0. Max: 120.0 | 2.0 Bar or PSI | | |
| LO OIL PRESS PRE-ALM | Disabled Warning Visual Alarm Audible Alarm Soft Shutdown Hard Shutdown | Disabled | | |
| LO OIL PRESS LMT | Min: 0.0 Max: 120.0 | 15.0 Bar or PSI | | |
| LO OIL PRESS ALM | Disabled Warning Visual Alarm Audible Alarm Soft Shutdown Hard Shutdown | Soft Shutdown | | |
| HI H2O TEMP PRE-LMT | Min: 50.0 Max: 300.0 | 125.0 °C or °F | | |
| HI H2O TEMP PRE-ALM | Disabled Warning Visual Alarm Audible Alarm Soft Shutdown Hard Shutdown | Disabled | | |
| HI H2O TEMP | Min: 50.0 Max: 300.0 | 212.0 °C or °F | | |
| HI H2O TEMP ALM | Disabled Warning Visual Alarm Audible Alarm Soft Shutdown Hard Shutdown | Soft Shutdown | | |
| LO H2O TEMP | Min: 0.0 Max: 200.0 | 20.0 °C or °F | | |
| LO H2O TEMP ALM | Disabled Warning Visual Alarm Audible Alarm Soft Shutdown Hard Shutdown | Disabled | | |

Synchronizer Menu

| Item: | Range: | Default: | As Set Value: | Note: |
|---------------------|--|----------|---------------|--------------|
| SYNC MODE | Check Permissive Run | Check | | |
| SYNC GAIN | Min: 0.01 Max: 100.00 | 0.10 | | |
| SYNC STABILITY | Min: 0.00 Max: 20.00 | 1.00 | | |
| VOLTAGE MATCHING | Disabled Enabled | Enabled | | |
| VOLTAGE WINDOW | Min: 0.1 Max: 10.0 | 1.0% | | |
| MAX PHASE WINDOW | Min: 2.0 Max: 20.0 | 10.0° | | |
| DWELL TIME | Min: 0.1 Max: 30.0 | 0.5 s | | |
| CB HOLD TIME | Min: 0.1 Max: 30.0 | 1.0 s | | |
| CLOSE ATTEMPTS | Min: 1 Max: 20 | 2 | | |
| RECLOSE DELAY | Min: 2 Max: 1200 | 30 s | | |
| SYNC RECLOSE ALM | Warning Visual Alarm Audible Alarm | Warning | | |
| SYNC TIMEOUT | Min: 0 Max: 1200 | 0 s | | 0 = NO LIMIT |
| SYNC TIMEOUT ALM | Warning Visual Alarm Audible Alarm | Warning | | |
| DEADBUSH CLOSURE | Disabled Enabled | Disabled | | |

Real Load Control Menu

| Item: | Range: | Default: | As Set Value: | Note: |
|---------------------|--|----------|---------------|------------------------------------|
| LOAD CONTROL MODE | Normal Soft Transfer Droop | Normal | | |
| LOAD CTRL GAIN | Min: 0.001 Max: 100.0 | 0.01 | | |
| LOADSHARE GAIN | Min: 0.1 Max: 2.0 | 0.72 | | |
| LOAD STABILITY | Min: 0.0 Max: 20.0 | 2.00 | | |
| LOAD DERIVATIVE | Min: 0.0 Max: 20.0 | 0.20 | | |
| LOAD CTRL FILTER | Min: 0.01 Max: 10.0 | 1.0 Hz | | |
| BASE LOAD REFERENCE | Min: 0.0 Max: 30000.0 | 50.0 kW | | |
| UNLOAD TRIP | Min: -10.0 Max: 30000.0 | 10 kW | | Must be set less than Baseload Ref |
| LOAD DROOP | Min: 0.0 Max: 50.0 | 5.0% | | |
| LOAD TIME | Min: 1.0 Max: 7200.0 | 10 s | | |
| UNLOAD TIME | Min: 1.0 Max: 7200.0 | 10 s | | |
| RAISE LOAD RATE | Min: 0.01 Max: 100.0 | 2.00%/s | | |
| LOWER LOAD RATE | Min: 0.01 Max: 100.0 | 2.00%/s | | |
| KW LOAD HIGH LIMIT | Min: 0.0 Max: 30000.0 | 30 kW | | |
| KW HIGH LIMIT ALARM | Disabled Warning Visual Alarm Audible Alarm | Warning | | |
| KW LOAD LOW LIMIT | Min: 0.0 Max: 30000.0 | 5.0 kW | | |
| KW LOW LIMIT ALARM | Disabled Warning Visual Alarm Audible Alarm | Disabled | | |
| kVA SWITCH LOW | Min: 0 Max: 30000 | 10 kVA | | |
| kVA SWITCH HIGH | Min: 0 Max: 30000 | 100 kVA | | |

Reactive Load Control Menu

| Item: | Range: | Default: | As Set Value: | Note: |
|---------------------|--|----------------|---------------|---|
| VAR/PF MODE | Disabled PF Control VAR Control | PF Control | | |
| VAR/PF GAIN | Min: 0.01 Max: 20.0 | 1.00 | | |
| VOLTS RAMP TIME | Min: 0 Max: 1000 | 60.0 s | | |
| VAR/PF SHARING GAIN | Min: 0.01 Max: 20.0 | 1.00 | | |
| VAR/PF STABILITY | Min: 0.0 Max: 20.00 | 1.00 | | |
| KVAR REFERENCE | Min: -20,000 Max: 20,000 | 10.0 kVAR | | + = generate (Lag) - = absorb (Lead) |
| PF REF | Min: -0.5 = .5 Lead Max: +.5 = .5 Lag | 0.0 = 1.00 Lag | | 0.0 = Unity PF + = Lag - = Lead |
| PF DEADBAND | Min: 0.0 Max: 1.0 | 0.005 | | |

Process Control Menu

| Item: | Range: | Default: | As Set Value: | Note: |
|--------------------|--|----------|---------------|-----------------|
| PROCESS ACTION | Direct Indirect | Indirect | | |
| PROCESS GAIN | Min: 0.001 Max: 100.0 | 0.10 | | |
| PROCESS STABILITY | Min: 0.0 Max: 20.0 | 1.0 s | | |
| PROCESS DERIVATIVE | Min: 0.0 Max: 20.0 | 0.1 s | | |
| PROCESS DEADBAND | Min: 0.3 Max: 5.0 | 0.3% | | % of Full Scale |
| PROCESS DROOP | Min: 0.0 Max: 50.0 | 0.0% | | |
| PROCESS FILTER | Min: 0.1 Max: 5.0 | 1.0 Hz | | |
| PROCESS REFERENCE | Min: -32,768 Max: 32,767 | 12.0 | | *Process Units |
| RAISE RATE | Min: 0.0 Max: 100.0 | 0.1 %/s | | |
| LOWER RATE | Min: 0.0 Max: 100.0 | 0.1 %/s | | |
| PROCESS HIGH LMT | Min: -32,768 Max: 32,767 | 20.0 | | *Process Units |
| PROC HI LMT ALM | Disabled Warning Visual Alarm Audible Alarm Soft Shutdown Hard Shutdown | Disabled | | |
| PROCESS LOW LMT | Min: -32,768 Max: 32,767 | 4.0 | | *Process Units |
| PROC LO LMT ALM | Disabled Warning Visual Alarm Audible Alarm Soft Shutdown Hard Shutdown | Disabled | | |
| PROCESS UNITS | mA V kW MW kVA MVA kVAR MVAR PF Degrees C Degrees F PSI kPA BAR | mA | | |
| PROCESS LOW VALUE | Min: -32,768 Max: 32,767 | 4.0 | | |
| PROCESS HIGH VALUE | Min: -32,768 Max: 32,767 | 20.0 | | |

Transfer Switch Menu

| Item: | Range: | Default: | As Set Value: | Note: |
|----------------------|--|-----------|---------------|-------|
| CHECK MAINS BREAKER | Disabled Enabled | Enabled | | |
| FAST XFER DELAY | Min: 0.1 Max: 30.0 | 1.0 s | | |
| MAINS STABLE DLY | Min: 1 Max: 30000 | 60 s | | |
| GEN STABLE DLY | Min: 1 Max: 30000 | 10 s | | |
| LOAD SURGE | Min: 25.0 Max: 300.0 | 100.0%/s | | |
| LOAD SURGE ALARM | Disabled Warning Loss of Mains Loss of Mains w/alarms | Warning | | |
| MAIN VOLT HIGH LMT | Min: 50.0 Max: 30000.0 | 240 Volts | | |
| MAIN VOLT HIGH ALARM | Disabled Warning Loss of Mains Loss of Mains w/alarms | Warning | | |
| MAIN VOLT LOW LMT | Min: 50.0 Max: 30000.0 | 200 Volts | | |
| MAIN VOLT LOW ALARM | Disabled Warning Loss of Mains Loss of Mains w/alarms | Warning | | |
| MAIN FREQ HIGH LMT | Min: 40.0 Max: 75.0 | 61.0 Hz | | |
| MAIN FREQ HIGH ALARM | Disabled Warning Loss of Mains Loss of Mains w/alarms | Warning | | |
| MAIN FREQ LOW LMT | Min: 40.0 Max: 75.0 | 59.0 Hz | | |
| MAIN FREQ LOW ALARM | Disabled Warning Loss of Mains Loss of Mains w/alarms | Disabled | | |
| LOM ACTION DELAY | Min: 0.1 Max: 30.0 | 0.1 s | | |

Sequencing and Comms Menu

| Item: | Range: | Default: | As Set Value: | Note: |
|---------------------|---|----------|---------------|-------|
| AUTO SEQUENCING | Disabled Enabled | Disabled | | |
| AUTO SEQUENCE DELAY | Min: 1 Max: 1200 | 120 s | | |
| MAX GEN LOAD | Min: 1 Max: 100 | 60% | | |
| NEXT GENSET DLY | Min: 1 Max: 1200 | 30 s | | |
| RATED LOAD DELAY | Min: 1 Max: 1200 | 5 s | | |
| MAX START TIME | Min: 1 Max: 1200 | 30 s | | |
| MIN GEN LOAD | Min: 1 Max: 100 | 30% | | |
| REDUCED LOAD DLY | Min: 1 Max: 1200 | 60 s | | |
| MAX STOP TIME | Min: 1 Max: 1200 | 60 s | | |
| 422 PROTOCOL | ServLink Modbus Upload Set Points | Modbus | | |
| Modbus ID | Min: 1 Max: 247 | 1 | | |
| Modbus Timeout | Min: 0.1 Max: 20.0 | 3.0 s | | |
| Modbus Reset | False True | False | | |

Calibration Menu

| Item: | Range: | As Set Value: | Note: |
|-------------------|-----------------------------|---------------|---------------|
| Process In scale | Min: 0.5 Max: 2.0 | | |
| Speed Bias offset | Min: -50.0 Max: 50.0 | | |
| Volts Bias offset | Min: -50.0 Max: 50.0 | | |
| PT Phase A scale | Min: 0.5 Max: 10.0 | | |
| PT Phase B scale | Min: 0.5 Max: 10.0 | | |
| PT Phase C scale | Min: 0.5 Max: 10.0 | | |
| CT Phase A offset | Min: -90.0 Max: 90.0 | | |
| CT Phase A scale | Min: 0.5 Max: 5.0 | | |
| CT Phase B offset | Min: -90.0 Max: 90.0 | | |
| CT Phase B scale | Min: 0.5 Max: 5.0 | | |
| CT Phase C offset | Min: -90.0 Max: 90.0 | | |
| CT Phase C scale | Min: 0.5 Max: 5.0 | | |
| Bus PT scale | Min: 0.5 Max: 10.0 | | |
| Synchronizer | Min: -1.0 Max: 1.0 | | |
| Battery VCO Gain | Min: -0.1000 Max: 0.1000 | | |
| Batt VCO offset | Min: -900.0 Max: 900.0 | | |
| Oil Pres Gain | Min: -1.000 Max: 1.000 | | |
| Oil Pres Offset | Min: -900.0 Max: 900.0 | | |
| Water Temp Gain | Min: -1.0 Max: 1.0 | | |
| Water Temp Offset | Min: -900.0 Max: 900.0 | | |
| NetComm Dropouts | Min: 0 Max: 50 | | |
| Calibrated Unit | False True | | Do Not Change |

Declarations

DECLARATION OF CONFORMITY

According to ISO/IEC Guide 22 and EN 45014

Manufacturer's Name: WOODWARD GOVERNOR COMPANY (WGC)
Industrial Controls Group

Manufacturer's Address: 1000 E. Drake Rd.
P.O. Box 1519
Fort Collins, CO USA 80525-1519

European Representative's Name: WOODWARD GOVERNOR NEDERLAND BV

European Representative's Address: Hoofdweg 601
P. O. Box 34
2130 AA Hoofddorp, The Netherlands

Model Name(s)/Number(s): EGCP-2

Conformance to Directive(s): 89/336/EEC COUNCIL DIRECTIVE of 03 May 1989 on the approximation of the laws of the Member States relating to electromagnetic compatibility.

73/23/EEC COUNCIL DIRECTIVE of 19 February 1973 on the harmonization of the laws of the Member States relating to electrical equipment designed for use within certain voltage limits.

Applicable Standards: EN 50081-2, August 1993: EMC Generic Emission Standard, Part 2: Industrial Environment.
EN 61000-6-2, April 1999: EMC Compatibility - Generic Standards - Immunity for Industrial Environments

EN 50178, October 1997: Electrical equipment for use in power installations.

We, the undersigned, hereby declare that the equipment specified above conforms to the above Directive(s).

MANUFACTURER

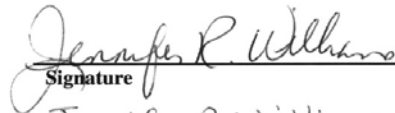

Signature

Jennifer R. Williams

Full Name

Engineering Project/Process Mng.

Position

WGC, Fort Collins, CO, USA

Place

8-22-00

Date

EGCP-2 Control Specifications

| | |
|----------------------------------|---|
| Woodward Part Numbers: | |
| 8406-120 | EGCP-2 Engine Generator Control, 150–300 Vac PT input |
| 8406-121 | EGCP-2 Engine Generator Control, 50–150 Vac PT input |
| Power Supply Rating | 9–32 Vdc (SELV) Maximum input voltage range |
| Power Consumption | Less than or equal 13 W nominal, 20 W maximum |
| Input Supply Voltage | Input Supply Current |
| 12 V (nominal) | 1.08 A |
| 24 V (nominal) | 542 mA |
| 32 V | 406 mA |
| PT input | 50–150 Vac, 8406-121 |
| CT input | 150–300 Vac, 8406-120 |
| Generator Frequency Range | 0–5 A rms |
| Magnetic Pickup | 40–70 Hz |
| Discrete Inputs (16) | 100–10 000 Hz |
| Process input | 5 mA source current when CLOSED to Switch Common (65) |
| Temperature and pressure inputs | 4–20 mA, 1–5 Vdc |
| Speed Bias | 0–200 Ω sensors, 4–20 mA transducer, or 0–5V transducer |
| Voltage Bias | ± 3 Vdc, 0.5–4.5 Vdc, 5 V peak 500 Hz PWM |
| Discrete Outputs (Relay Outputs) | ± 1 Vdc, ± 3 Vdc, ± 9 Vdc |
| Communication Ports | 10 A, 250 Vac Resistive |
| Ambient Operating Temperature | 249 W (1/3 hp), 125 Vac (7.2 A, 0.4–0.5 PF) |
| Storage Temperature | 10 A, 30 Vdc Resistive |
| Humidity | RS-485, RS-422 |
| Mechanical Vibration | –20 to +70 °C (–4 to +158 °F)(around outside of EGCP-2 chassis) |
| Mechanical Shock | –40 to +105 °C (–40 to +221 °F) |
| Equipment Classification | 95% at 20 to 55 °C (68 to 131 °F) |
| Air Quality | SV2 5–2000 Hz @ 4 G and RV1 10–2000 Hz @ 0.04 G ² /Hz |
| Installation Overvoltage | US MIL-STD 810C, Method 516.2, Procedure I (basic design test), Procedure II (transit drop test, packaged), Procedure V (bench handling) |
| Ingress Protection | Class 1 (grounded equipment) |
| Regulatory Compliance | Pollution Degree II |
| European Compliance for CE Mark: | Category III |
| EMC Directive | Will meet the requirements of IP56 as defined in IEC529 when installed in a suitable atmospherically vented enclosure. Also meets Type 4 requirements. |
| Low Voltage Directive | Declared to 89/336/EEC COUNCIL DIRECTIVE of 03 May 1989 on the approximation of the laws of the member states relating to electromagnetic compatibility. Declared to the 73/23/EEC COUNCIL DIRECTIVE of 19 February 1973 on the harmonization of the laws of the Member States relating to electrical equipment designed for use within certain voltage limits. |
| North American Compliance: | |
| UL | UL Listed for Ordinary Locations at 70 °C maximum Ambient. For use in the United States and Canada. UL File E97763 |
| CSA | CSA Certified for Ordinary Locations at 70 °C maximum Ambient. For use in the United States and Canada. Certificate 1159277 |
| NOTE | Wiring must be in accordance with applicable electric codes with the authority having jurisdiction. |

We appreciate your comments about the content of our publications.

Send comments to: icinfo@woodward.com

Please reference publication **26174B**.



PO Box 1519, Fort Collins CO 80522-1519, USA
1000 East Drake Road, Fort Collins CO 80525, USA
Phone +1 (970) 482-5811 • Fax +1 (970) 498-3058

Email and Website—www.woodward.com

**Woodward has company-owned plants, subsidiaries, and branches,
as well as authorized distributors and other authorized service and sales facilities throughout the world.**

Complete address / phone / fax / email information for all locations is available on our website.