

36527



DPG-23XX-001
Digital Governor

APECS[®] Programmable Governor for
Off-Highway Vehicle Applications

User Manual

Manual 36527



WARNING

Read this entire manual and all other publications pertaining to the work to be performed before installing, operating, or servicing this equipment. Practice all plant and safety instructions and precautions. Failure to follow instructions can cause personal injury and/or property damage.

The engine, turbine, or other type of prime mover should be equipped with an overspeed shutdown device to protect against runaway or damage to the prime mover with possible personal injury, loss of life, or property damage.

The overspeed shutdown device must be totally independent of the prime mover control system. An overtemperature or overpressure shutdown device may also be needed for safety, as appropriate.



CAUTION

To prevent damage to a control system that uses an alternator or battery-charging device, make sure the charging device is turned off before disconnecting the battery from the system.

Electronic controls contain static-sensitive parts. Observe the following precautions to prevent damage to these parts.

- Discharge body static before handling the control (with power to the control turned off, contact a grounded surface and maintain contact while handling the control).
- Avoid all plastic, vinyl, and Styrofoam (except antistatic versions) around printed circuit boards.
- Do not touch the components or conductors on a printed circuit board with your hands or with conductive devices.

Woodward Governor Company reserves the right to update any portion of this publication at any time. Information provided by Woodward Governor Company is believed to be correct and reliable. However, no responsibility is assumed by Woodward Governor Company unless otherwise expressly undertaken.

© Woodward 2004
All Rights Reserved

Contents

ELECTROSTATIC DISCHARGE AWARENESS	III
CHAPTER 1. GENERAL INFORMATION	1
Introduction	1
CHAPTER 2. GOVERNOR SPECIFICATIONS	2
Electrical	2
Mechanical.....	2
Performance	2
Configurations.....	2
User Interface Operation	3
Operating Modes.....	3
Keypad.....	4
LED Display	5
CHAPTER 3. PARAMETER REFERENCE	7
Parameter List.....	7
3.1 No. of Flywheel Teeth	8
3.2 Remote Speed Min	8
3.3 Remote Speed Max	9
3.4 Set Speed A.....	9
3.5 Idle Speed.....	10
3.6 Proportional.....	11
3.7 Integral	11
3.8 Derivative	11
3.9 OVG @ Remote Set Speed Min	12
3.10 OVG @ Remote Speed Max.....	12
3.11 OVG @ Set Speed A	12
3.12 OVG @ Set Speed B	12
3.13 Gain Factor	12
3.14 Speed Filter.....	13
3.15 Accel Rate.....	13
3.16 Decel Rate	14
3.17 Startup Rate	14
3.18 Startup Limit.....	15
3.19 Torque Limit	15
3.20 Integral Low Limit.....	15
3.21 Integral High Limit	16
3.22 Password	16
3.23 Overspeed Limit.....	17
3.24 Set Speed A Min	17
3.25 Set Speed A Max	17
3.26 Set Speed B Min	17
3.27 Set Speed B Max	17
3.28 Duty Cycle Limit	17
3.29 Input Polarity	18
3.30 E1 Handler Select	18
3.31 Startup Speed	18
3.32 Startup Duty Cycle	19
3.33 Speed Pot Action	19
CHAPTER 4. UNIVERSAL PST	20
Introduction	20
Features.....	20
Universal PST Requirements	20
Acquiring Universal PST	20
Wiring the COMM Port to a PC.....	21

CHAPTER 5 CALIBRATION INSTRUCTIONS	22
Basic Adjustments	22
Tuning Methodology	22
Remote Speed Potentiometer Calibration Procedure	23
CHAPTER 6. INSTALLATION INSTRUCTIONS	24
DPG 2302-001 Terminal Descriptions	24
DPG 2302-001 Wiring Diagram	24
DPG 2345-001 Terminal Descriptions	25
DPG 2345-001 Wiring Diagram	25
Mode Selection	26
Preferred Wiring for Cruise Control	27
CHAPTER 7 DIAGNOSTICS & TROUBLESHOOTING	28
Display Codes	28
Troubleshooting Table	28
CHAPTER 8. SERVICE OPTIONS	30
Product Service Options	30
Replacement/Exchange	30
Flat Rate Repair	31
Flat Rate Remanufacture	31
Returning Equipment for Repair	31
Packing a Control	31
Return Authorization Number	32
Replacement Parts	32
How to Contact Woodward	32
Engineering Services	33
Technical Assistance	34

Electrostatic Discharge Awareness

All electronic equipment is static-sensitive, some components more than others. To protect these components from static damage, you must take special precautions to minimize or eliminate electrostatic discharges.

Follow these precautions when working with or near the control.

1. Before doing maintenance on the electronic control, discharge the static electricity on your body to ground by touching and holding a grounded metal object (pipes, cabinets, equipment, etc.).
2. Avoid the build-up of static electricity on your body by not wearing clothing made of synthetic materials. Wear cotton or cotton-blend materials as much as possible because these do not store static electric charges as much as synthetics.
3. Keep plastic, vinyl, and Styrofoam materials (such as plastic or Styrofoam cups, cup holders, cigarette packages, cellophane wrappers, vinyl books or folders, plastic bottles, and plastic ash trays) away from the control, the modules, and the work area as much as possible.
4. Do not remove the printed circuit board (PCB) from the control cabinet unless absolutely necessary. If you must remove the PCB from the control cabinet, follow these precautions:
 - Do not touch any part of the PCB except the edges.
 - Do not touch the electrical conductors, the connectors, or the components with conductive devices or with your hands.
 - When replacing a PCB, keep the new PCB in the plastic antistatic protective bag it comes in until you are ready to install it. Immediately after removing the old PCB from the control cabinet, place it in the antistatic protective bag.



CAUTION

To prevent damage to electronic components caused by improper handling, read and observe the precautions in Woodward manual 82715, *Guide for Handling and Protection of Electronic Controls, Printed Circuit Boards, and Modules*.

Chapter 1.

General Information

Introduction

The DPG-23XX-001 digital governor is used primarily to govern diesel or gas fueled engines of off-highway vehicles. This microprocessor based, digital controller performs across a wide speed range and allows adjustment of all governor features through the built-in user interface. Properly tuned, this governor delivers fast engine response to speed or load change while providing precise stable isochronous operation.

Separately programmable Proportional, Integral, and Derivative gains are provided for tailoring governor response to many engine applications. Other adjustments include acceleration and deceleration ramp rates, startup and torque limits.

The governor's internal FAILSAFE reacts instantly to loss of the engine speed signal or loss of remote speed potentiometer signal, allowing the actuator to return to minimum fuel.

Features include:

- Automatic calibration of the remote speed potentiometer
- Isochronous speed control
- User friendly / operator adjustable
- Precision frequency control: 0.25%
- Superior temperature stability
- Reverse battery protection
- Input voltage range: 9-30 Vdc
- Smoke control on start up
- Remote setup
- Serial communication port

Actuator Compatibility:

DYNA 2000	DYNA 7000	DYNA 8000
DYNA 2500	DYNA 70025	DYNA 8200
Power Flow Gas Valves		DYNA 8400

Other Models Available:

DPG-2100 Series – for Genset Applications
DPG-2200 Series – for Genset Applications
DPG-2401 Series – for EFC Applications

Chapter 2. Governor Specifications

The governor's main electrical and mechanical specifications are listed here along with several performance characteristics.

Electrical

Operating Voltages:	9 Vdc minimum to 30 Vdc maximum
Maximum Controlled Output Current:	7 A
Maximum Surge Current:	14 A for ten seconds
Connections:	Terminal strip with 13 terminals
Input Signal from Magnetic Pickup:	2.0 VAC RMS minimum during cranking

Mechanical

Ambient Operating Temperature:	-40°F to +185°F (-40°C to +85°C)
Sealing:	Oil, water, and dust resistant via conformal coating and die cast enclosure
Weight:	.75 lbs (.34 kg)
Connection	13-terminal Euro-style connector

Performance

Steady State Speed Band:	± .25% over ambient operating temperature range
Engine Speed MPU Measurement Range:	10 MPU Hertz to 14,000 MPU Hertz
Governing Speed Range with MPU:	500 MPU Hertz to 11,000 MPU Hertz
Engine Speed Ignition Measurement Range:	2 Hertz to 350 Hertz
Governing Speed Range with Ignition:	25 Hertz to 300 Hertz

Configurations

MODEL NO.	CONNECTOR STYLE OPTIONS	SPEED SENSING OPTIONS		ADJ. SET SPEEDS	MODE SELECT INPUTS (DIGITAL INPUTS)
	13-wire Euro	Magnetic Pickup	Ignition Sense		
DPG-2302-001	*	*		2 + Remote Speed Pot and Pedal Hold	2
DPG-2345-001	*		*	2 + Remote Speed Pot and Pedal Hold	2

User Interface Operation

The user interface has two distinct behaviors that you should familiarize yourself with in order to select parameters and adjust them. These behaviors are described in the Operating Modes section below.

A 4-pushbutton keypad and a 2-digit LED display make up the built-in user interface. The pushbuttons, also called keys, are described in the section named Keypad. The LED display is described in the section named LED Display.

Remote access to the governor's parameter settings is available when the governor's COMM port is connected to a computer running our Universal PST application.

Operating Modes

The user interface operates in two modes: PARAMETER SELECT MODE and PARAMETER EDIT MODE. For each of these modes, the keypad and the display have a unique way of operating.

The following table provides a quick reference to the behavior of the display and the function of each key when a particular operating mode is active.

PARAMETER SELECT MODE		PARAMETER EDIT MODE	
LED Display	The ID number of a parameter listed on the governor's label is blinking on and off	LED Display	The value of the selected parameter is displayed. A blinking decimal point means the value can be modified; otherwise, the value is view only.
INC key	Increase the parameter ID number by one	INC key	Increase the selected parameter's value.
DEC key	Decrease the parameter ID number by one	DEC key	Decrease the selected parameter's value.
SELECT key	Activate PARAMETER EDIT MODE on the parameter whose number was blinking	SELECT key	Return to PARAMETER SELECT MODE and ignore changes made to the parameter's value
ENTER	Display the version number of the governor's programming	ENTER	Save the parameter's new value, and return to PARAMETER SELECT MODE
INC & DEC Simultaneously	Turn on all LED segments as a test	INC & DEC Simultaneously	Use to display the upper digits of values larger than 99

PARAMETER SELECT MODE is the mode used to *select* a parameter for viewing and editing. This mode is active when the 2-digit value being displayed is blinking. The value displayed is a parameter's identification (ID) number. The controller's label lists each user-adjustable parameter and its corresponding ID number.

PARAMETER EDIT MODE is the mode that displays the *selected* parameter's value and allows the value to be modified. This mode is active when the 2-digit value displayed is on and no longer blinking. The value displayed is the selected parameter's current value. The display's decimal points have several different meanings while in PARAMETER EDIT MODE. These are described below.

- Decimal point blinking - the selected parameter's value can be modified.
- Decimal point not blinking - the selected parameter's value cannot be modified; parameter editing is locked and values can only be viewed. This is the case when password protection is active and the unlock code has not been entered. Read about the Password parameter in

the Parameter Reference chapter for more information about using password protection.

- Right digit's decimal point is blinking or ON – the lower two digits (the tens digit and the ones digit) of a parameter's 4-digit value are being displayed.
- Left digit's decimal point is ON – the upper two digits (the thousands digit and the hundreds digit) of a parameter's 4-digit value are being displayed. The upper two digits of a parameter are always view only and can never be modified directly. The upper two digits change when the lower digits overflow (transition from 99 to 00) or underflow (transition from 00 to 99).

Keypad

The keypad consists of four pushbuttons named ENTER, SELECT, INC, and DEC.

ENTER Key

The ENTER key is used to exit PARAMETER EDIT MODE and return to PARAMETER SELECT MODE while saving the parameter's new value to nonvolatile memory. Nonvolatile memory is where parameter values are stored so that they are remembered even when the governor is not being powered. In PARAMETER SELECT MODE, pressing the ENTER key displays the version number of the governor's programming.

SELECT Key

The SELECT key is used to enter PARAMETER EDIT MODE from PARAMETER SELECT MODE once a particular parameter has been selected for editing.

The SELECT key is also used to escape from PARAMETER EDIT MODE and return to PARAMETER SELECT MODE without saving a change in a parameter's value. The value a parameter had when PARAMETER EDIT MODE was entered is restored.

INC (increase) Key

The INC key is used to increase the displayed value.

In PARAMETER SELECT MODE, each press of the INC key will cause the next higher parameter identification number to be displayed. When the maximum parameter identification number is reached, the next INC key press will cause the first parameter ID number to be displayed.

For example: If the controller's label lists 34 parameters, then pressing the INC key when the display is blinking the value 34 will cause the display to wrap around to the first parameter listed and begin blinking the value 01.

In PARAMETER EDIT MODE, each INC key press will increase a parameter's current value. If the INC key is held down while in PARAMETER EDIT MODE the value will automatically continue to be increased at gradually faster and faster rates until the INC key is released or the parameter's maximum allowed value is reached. When the lower two digits display a 99, pressing the INC (increase key) will cause the lower two digits to display a 00 and the hundreds digit will have been increased by 1.

DEC (decrease) Key

The DEC (decrease) key is used to decrease the displayed value.

In PARAMETER SELECT MODE, each press of the DEC key will cause the next lower parameter number to be displayed. When the first parameter identification number is reached, the next DEC key press will cause the last parameter ID number to be displayed.

For example: If the controller's label lists 34 parameters, then pressing the DEC key when the display is blinking the value 01 will cause the display to wrap around to the last parameter listed, which in this case is 34, and blink this new value.

In PARAMETER EDIT MODE, each DEC key press will decrease a parameter's current value. If the DEC key is held down while in PARAMETER EDIT MODE the value will automatically continue to be decreased at gradually faster and faster rates until the DEC key is released or the parameter's minimum allowed value is reached. When the lower two digits display a 00, pressing the DEC (decrease key) will cause the lower two digits to display a 99 and the hundreds digit will have been decreased by 1.

INC and DEC Keys Together

In PARAMETER EDIT MODE, the INC and DEC keys are used together to view the value of the upper two digits of a 4-digit number.

Press and hold both INC and DEC simultaneously to view the value of a 4-digit number's upper two digits. Note that the left digit's decimal point is turned on to indicate that the thousands and the hundreds digits are being displayed.

Release INC and DEC and now the tens and the ones digits are again being displayed. Note that the right digit's decimal point is blinking if editing is allowed or just ON if editing is not allowed.

Note: Not all parameters are 4-digit numbers, in which case the upper digits will always display 0.0 (zero dot zero).

In PARAMETER SELECT MODE, pressing both the INC and DEC keys at the same time will cause all LED segments to be turned on. This serves as an LED test. Release the keys to resume displaying the parameter ID number.

LED Display

The two 7-segment LED's along with each digit's corresponding decimal point are used to display values and indicate the operating mode of the user interface.

When the value being displayed by the two 7-segment LED's is blinking, PARAMETER SELECT MODE is active.

When the value displayed is not blinking, the selected parameter's value is being displayed and the user interface is in PARAMETER EDIT MODE. The decimal points further indicate which half of a 4-digit value is being displayed and whether editing is allowed.

The right digit's decimal point is used to indicate that the lower 2 digits of a value (the tens and the ones digits) are being displayed. When the right decimal point is blinking, it means that the value can be modified using the INC key or the DEC key. No blinking means that editing is not allowed or is password protected.

The left digit's decimal point is used to indicate that the upper 2 digits of a value (the thousands and the hundreds digits) are being displayed. The upper 2 digits are always view only so the right decimal point does not blink. Changes to the upper digits occur when a parameter's lower digits overflow or underflow during editing.

An overflow occurs when the value 99 is displayed and the INC key is pressed (assuming this is not the parameter's maximum value). This will cause the displayed value to become 00 while the non-displayed value in the parameter's upper 2 digits will be increased by one. You can verify this by pressing both INC and DEC at the same time to view the new value in the upper digits. For example: If the full 4-digit value of the parameter you are editing is currently 1099, then after pressing the INC key the parameter's new value will be 1100.

An underflow occurs when the value 00 is displayed and the DEC key is pressed (assuming this is not the parameter's minimum value). This will cause the displayed value to become 99 while the non-displayed value in the parameter's upper 2 digits will be decreased by one. You can verify this by pressing both INC and DEC at the same time to view the new value in the upper digits. For example: If the full 4-digit value of the parameter you are editing is currently 1800, then after pressing the DEC key the parameter's new value will be 1799.

When values exceeding 9,999 are to be displayed, the controller uses the hexadecimal numbering system to represent the value of the thousands position.

Example 1: The desired set speed is 10,069 Hertz. The upper two digits displayed by the controller will be [A.0], and the lower 2 digits displayed will be [69.].

DECIMAL TO HEXADECIMAL CONVERSION CHART	
Decimal Value	Hexadecimal Equivalent
10	A
11	B
12	C
13	D
14	E
15	F

Example 2: The desired set speed is 10,972 Hertz. The upper two digits displayed by the controller will be [A.9] and the lower 2 digits displayed will be [72.].

Chapter 3. Parameter Reference

This chapter provides information regarding each parameter's function. Each of this chapter's subsections provides information about a single parameter.

Subsection numbering corresponds to the parameter numbering on the governor's label to make it easier to locate information about the parameter of interest. For example: Parameter 6. PROPORTIONAL is described in subsection 3.6 (chapter 3 subsection 6).

The table below lists each of the parameters and their default, minimum, and maximum values. Note that several of the parameters have minimum and maximum values set by other parameters.

Default, minimum and maximum values in parenthesis () apply when controller uses ignition pulses to sense engine speed.

Note also that all *Speed* and *Rate* values are shown as magnetic pick-up Hertz values (parameters 2-5, 15-17, 24-27, 31). Changing the No. of Flywheel Teeth will cause different default values to be displayed based on the Hertz to RPM formula described in subsection 3.1 below.

Parameter List

DPG-2302-001 & DPG-2345-001 (ignition)

PARAMETER NAME	DEFAULT	MINIMUM	MAXIMUM
1. No. of Flywheel Teeth or Pulses per Revolution	0	0	572
2. Remote Set Speed Min	1000 (25)	10 (2)	Remote Set Speed Max
3. Remote Set Speed Max	1000 (25)	Remote Set Speed Min	11,000 (300)
4. Set Speed A	1000 (25)	Set Speed A Min	Set Speed A Max
5. Set Speed B	1000 (25)	Set Speed B Min	Set Speed B Max
6. Proportional	25	1	99
7. Integral	50	0	99
8. Derivative	25	0	99
9. OVG @ Remote Speed Min	20	1	99
10. OVG @ Remote Speed Max	0	0	99
11. OVG @ Set Speed A	20	1	99
12. OVG @ Set Speed B	20	1	99
13. Gain Factor	20	1	99
14. Speed Filter	16	1	24
15. Accel Rate	3000	1	9999
16. Decel Rate	3000	1	9999
17. Startup Rate	3000	1	9999
18. Startup Limit	1000	1	1000

19. Torque Limit	1000	0	1000
20. Integral Low Limit	0	0	Integral High Limit
21. Integral High Limit	99	Integral Low Limit	99
22. Password	0	0	99
23. Overspeed Limit	100	0	100
24. Set Speed A Min	10 (2)	10 (2)	Set Speed A
25. Set Speed A Max	11000 (300)	Set Speed A	11000 (300)
26. Set Speed B Min	10 (2)	10 (2)	Set Speed B
27. Set Speed B Max	11000 (300)	Set Speed B	11000 (300)
28. Duty Cycle Limit	95	5	95
29 Input Polarity	0	0	1
30. E1 Handler Select	0	0	1
31. Startup Speed	1000 (25)	10 (2)	11000 (300)
32. Startup Duty Cycle	30	5	95
33. Speed Pot Action	0	0	1

3.1 No. of Flywheel Teeth

This parameter provides the conversion factor needed by the governor to display speeds as RPM values instead of Hertz values. Adjusting this parameter is optional. To use this parameter correctly, you must know the exact number of flywheel teeth that pass by the magnetic pickup in one revolution of the engine.

The default value of 0 disables Hz to RPM conversions so all set speeds are displayed in MPU (magnetic pick-up) Hertz. Setting this parameter to a value other than zero enables Hz to RPM conversion.

Adjust this parameter to a value equal to the exact number of pulses that the MPU delivers to the governor in one revolution of the engine to display set speeds in RPM. The formula used to convert the magnetic pickup signal from a Hertz value to a RPM value is:

$$\frac{[(MpuHertz) \times (60s)]}{[NumberOfTeeth]} = [EngineRPM]$$

For example:

$$\frac{[(3960Hz) \times (60s)]}{[132Teeth]} = [1800RPM]$$

The following derivation of the above formula can be used to convert from RPM to Hertz.

$$\frac{[(EngineRPM) \times (NumberOfTeeth)]}{[60s]} = [MpuHertz]$$

3.2 Remote Speed Min

REMOTE SET SPEED MIN is the governor's minimum target speed when the Remote Speed Pot is selected. The controller will read the remote speed pot position when DIG IN A and DIG IN B (terminals 11 and 12) are OPEN and the startup sequence is complete. See the Installation chapter for details about wiring switches between DIG IN A (terminal 11), DIG IN B (terminal 12) and +5 Vdc (terminal 13) in order to use SET SPEED A, SET SPEED B, and PEDAL HOLD MODE.

The default value for REMOTE SET SPEED MIN is 1000 MPU Hertz (25 Hertz Ignition). REMOTE SET SPEED MIN's adjustable range extends from 10 hertz MPU (2 Hertz Ignition) to REMOTE SET SPEED MAX (parameter 3).

When REMOTE SET SPEED MIN values greater than 9999 are displayed, the left most digit uses the capital letter A to represent 10000 and uses the lower case letter b to represent 11000.

For example: If REMOTE SET SPEED MIN is set to 11000, then the upper 2 digits will be displayed by the controller as [b.0] and the lower 2 digits will display [00.]

NOTE: If the No. of Flywheel Teeth parameter is used then Remote Set Speed Min will be displayed as RPM.

3.3 Remote Speed Max

REMOTE SET SPEED MAX is the governor's maximum target speed when the Remote Speed Pot is selected. The controller will read the remote speed pot position when DIG IN A and DIG IN B (terminals 11 and 12) are OPEN and the startup sequence is complete. See the chapter Installation Instructions for details about wiring a switches between DIG IN A (terminal 11), DIG IN B (terminal 12) and +5VDC (terminal 13) in order to use SET SPEED A, SET SPEED B, and PEDAL HOLD MODE.

The default value for REMOTE SET SPEED MIN is 1000 MPU Hertz (25 Hertz Ignition). REMOTE SET SPEED MAX's adjustable range extends from REMOTE SET SPEED MIN (parameter 2) to 11,000 hertz (300 Hertz Ignition).

When REMOTE SET SPEED MAX values greater than 9999 are displayed, the left most digit uses the capital letter A to represent 10000 and uses the lower case letter b to represent 11000.

For example: If REMOTE SET SPEED MAX is set to 11000, then the upper 2 digits will be displayed by the controller as [b.0] and the lower 2 digits will display [00.]

NOTE: If the No. of Flywheel Teeth parameter is used then Remote Set Speed Max will be displayed as RPM.

3.4 Set Speed A

SET SPEED A is the governor's target speed when the DIG IN A (terminal 11) is at 5 Volts (terminal 13) and DIG IN B (terminal 12) is OPEN and the startup sequence has completed. The startup sequence is complete when the target speed and the engine speed reach the set speed. See the Installation chapter for details about wiring switches between DIG IN A (terminal 11), DIG IN B (terminal 12) and +5 Vdc (terminal 13) in order to use SET SPEED A, SET SPEED B, and PEDAL HOLD MODE.

If the governor's DIG IN A and DIG IN B inputs are not used the Remote Speed Pot determines the governor's target speed after the startup sequence is completed.

The default value for SET SPEED A is 1000 MPU Hertz (25 Hertz Ignition). SET SPEED A's adjustable range extends from SET SPEED A MIN (parameter 24) to SET SPEED A MAX (parameter 25).

When SET SPEED A values greater than 9999 are displayed, the left most digit uses the capital letter A to represent 10000 and uses the lower case letter b to represent 11000.

For example: If SET SPEED A is set to 10750, then the upper 2 digits will be displayed by the controller as [A.7] and the lower 2 digits will display [50.]

NOTE: If the No. of Flywheel Teeth parameter is used then Set Speed A will be displayed as RPM.

3.5 Idle Speed

SET SPEED B is the governor's target speed when DIG IN A (terminal 11) is OPEN and DIG IN B (terminal 12) is at 5 volts (terminal 13) and the startup sequence has completed. The startup sequence is complete when the target speed and the engine speed reach the set speed. See the Installation chapter for details about wiring a switches between DIG IN A (terminal 11), DIG IN B (terminal 12) and +5 Vdc (terminal 13) in order to use SET SPEED A, SET SPEED B, and PEDAL HOLD MODE.

If the governor's DIG IN A and DIG IN B inputs are not used the Remote Speed Pot determines the governor's target speed after the startup sequence is completed.

The default value for SET SPEED B is 1000 MPU Hertz (25 Hertz Ignition). SET SPEED B's adjustable range extends from SET SPEED B MIN (parameter 26) to SET SPEED B MAX (parameter 27).

When SET SPEED B values greater than 9999 are displayed, the left most digit uses the capital letter A to represent 10000 and uses the lower case letter b to represent 11000.

For example: If SET SPEED B is set to 10750, then the upper 2 digits will be displayed by the controller as [A.7] and the lower 2 digits will display [50.]

NOTE: If the No. of Flywheel Teeth parameter is used then Idle Speed will be displayed as RPM.

3.6 Proportional

The proportional term is one of the interrelated PID terms that determine how well DPG-23XX series controller governs the engine's speed. A speed change creates a speed error (the difference between the target speed and the actual speed.) The proportional gain controls the size of the governor output response to a step change in the speed error.

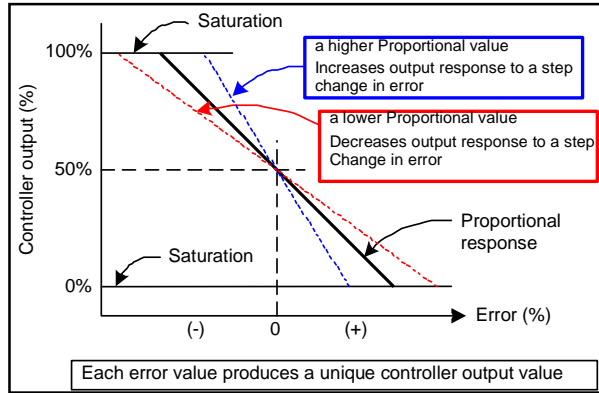

3.7 Integral

The integral term is one of the interrelated PID terms that determine how well a DPG-2401-001 controller governs the engine's speed. The integral term acts to drive speed error to zero. In a proportional only control with constant load, there will be a constant speed error that inversely relates to the proportional gain of the system. The integral term is key to

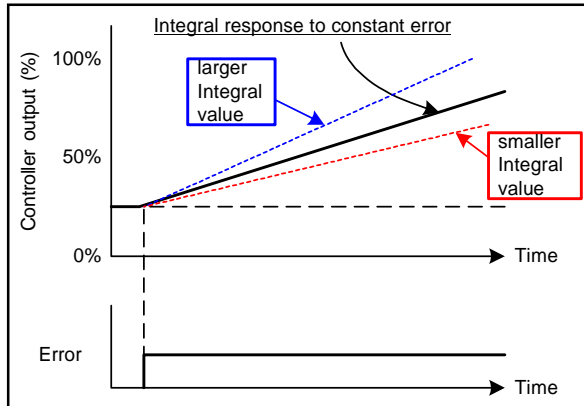

isochronous speed control. This term eliminates the difference between the programmed set speed and the actual speed. The integral gain changes the time it takes to drive the error to zero.

Note: Integral is needed to eliminate speed offsets due to proportional gain and should never be left at zero.

3.8 Derivative

The derivative term is one of the interrelated PID terms that determine how well a DPG-2401-001 controller governs the engine's speed. The derivative responds to the rate of change in the speed error. This parameter is primarily used to dampen very rapid oscillations resulting from large speed changes. The derivative responds to engine acceleration or deceleration. If the engine speed approaches the target speed at a fast rate, the

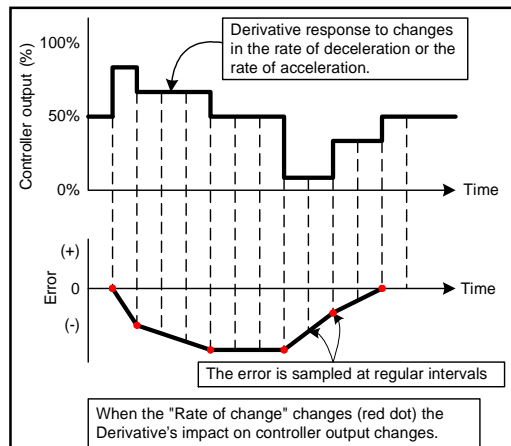

derivative acts to minimize or eliminate overshoot. A zero value is allowed but systems typically require some derivative gain to improve overall engine speed control.

3.9 OVG @ Remote Set Speed Min

This gain acts as the multiplier on the three PID terms (proportional, integral, and derivative) when the Remote Speed Pot is selected to set the active target speed. This gain term is adjustable from 01 to 99.

This value along with the Gain at Remote Speed Max value is used to select between single point gain vs. dual point gain. When OVG @ Remote Speed Max is zero, the Gain at Remote Speed Min value is used over the full speed range of the remote speed pot.

When Gain at Remote Speed Max is a non-zero value, dual point sloped gain is used and a new gain value is computed based on the current speed

3.10 OVG @ Remote Speed Max

This gain acts as the multiplier on the three PID terms (proportional, integral, and derivative) when the Remote Speed Pot is selected as the active target speed. This gain term is adjustable from 00 to 99.

When a non-zero value is entered, dual point sloped gain is used and a new gain value is computed based on the current speed.

3.11 OVG @ Set Speed A

This gain acts as the multiplier on the three PID terms (proportional, integral, and derivative) when Set Speed A is selected as the active target speed. This gain term is adjustable from 01 to 99.

3.12 OVG @ Set Speed B

This gain acts as the multiplier on the three PID terms (proportional, integral, derivative) when Set Speed is selected as the active target speed. This gain term is adjustable from 01 to 99.

3.13 Gain Factor

The gain factor parameter is used to obtain more range of adjustment from the PID terms. In other words, if any of the PID terms or the overall gain terms reach their adjustment limits then this value can be modified to provide for more range of adjustment in the PID and OVG terms.

For example, if the PID terms are set to 90, 80, and 50 respectively and the Gain Factor is set to 20, then doubling the Gain Factor by setting it to 40 allows the PID terms to be halved to 45, 40, and 25 respectively. These new settings are equivalent to the previous settings with respect to the governor's tuning response and now allow the PID terms to be adjusted higher if needed.

3.14 Speed Filter

This parameter indicates the number of flywheel teeth to use when computing an average engine speed and is used to dampen out speed measurement variations that can make PID tuning difficult. But, keep in mind the following:

- Too much filtering will slow down the governor's response to speed changes.
- Too little filtering can make the governor overly sensitive and tuning difficult.

There is measurable acceleration and deceleration that occurs between cylinder firings. As a general rule, less filtering is required the more engine cylinders there are. This is because the number of acceleration-deceleration cycles increases and these oscillations will have lower amplitude. With more cylinders, there is less time for the speed to slow down before the next cylinder firing.

Rotational mass also affects the amount of speed signal filtering needed. The more rotational mass, the less filtering is needed. The less rotational mass, the more filtering is needed.

For installations using a magnetic pickup to sense engine speed:

Typically, the value 24 works well on small 3- or 4-cylinder engines. A value of 16 is recommended for 6- or 8-cylinder engines. The following formula can also be used to derive a good starting point for the speed filter value for a given engine application. Round the result to the nearest integer. The maximum value allowed is 24.

$$[(\text{No. of flywheel teeth}) / (\text{No. of engine cylinders})] * 0.75 = \text{speed_filter_value}$$

For installations using ignition pulses to sense engine speed:

It is recommended that the Speed Filter be at least equal to the number of ignition pulses per one revolution of the engine. A good starting point would be 2 times the number of ignition pulses per one revolution of the engine.

$$[(\text{pulses_per_rev}) * (2)] = \text{speed_filter_value}$$

3.15 Accel Rate

This rate specifies how fast the governor should increase the engine's speed when a new higher target speed is made active. The parameter value is specified in MPU (magnetic pickup) Hz per second based on the following formula.

$$[(\text{higher_speed_in_Hertz}) - (\text{lower_speed_in_Hertz})] / (\text{ramp_time_in_seconds}) = \text{accel_rate_value}$$

For example, suppose Set Speed A is 3300 Hertz and Set Speed B is 3960 Hertz. The governor is currently controlling the engine at 3300 Hertz (Set Speed A), when Set Speed B is selected as the active target speed. It is desired that the new speed of 3960 be reached in precisely 2 seconds. The following formula determines the value needed by Accel Rate to increase the engine speed from Set Speed A to Set Speed B in 2 seconds.

$$[(\text{Set Speed B}) - (\text{Set Speed A})] / (\text{N seconds}) = \text{accel_rate_value in Hertz per sec.}$$

$$[3960 - 3300] / 2 = 330 \text{ Hertz per second}$$

3.16 Decel Rate

The Decel Rate specifies how fast the governor should decrease the engine's speed when a new lower target speed is made active. The parameter value is specified in MPU (magnetic pickup) Hertz per second based on the following formula.

$$\frac{[(\text{higher_speed_in_Hertz}) - (\text{lower_speed_in_Hertz})]}{(\text{ramp_time_in_seconds})} = \text{decel_rate_value}$$

For example, suppose Set Speed A is 4170 Hertz and Set Speed B is 3475 Hertz. The governor is currently controlling the engine at 4170 Hertz (Set Speed A), when Set Speed B becomes the active target speed. It is desired that the new speed of 3475 be reached in precisely 1.5 seconds. The following formula determines the value needed by Decel Rate to decrease the engine speed from Set Speed A to Set Speed B in 1.5 seconds.

$$\begin{aligned} & [(\text{Set Speed A}) - (\text{Set Speed B})] / (\text{N seconds}) = \text{decel_rate_value in Hertz per sec.} \\ & [4170 - 3475] / 1.5 = 463 \text{ Hertz per second} \end{aligned}$$

3.17 Startup Rate

This parameter is used to achieve a smooth controlled engine start. On diesel engines, this feature is also useful for minimizing exhaust smoke at startup.

The startup rate specifies how fast the governor should increase the engine speed when the engine is started. The rate value indicates Hertz per second. The formula to use for determining a precise Startup Rate is shown below.

$$\frac{[(\text{final_target_speed_in_Hertz}) - (\text{crank_speed_in_Hertz})]}{(\text{ramp_time_in_seconds})} = \text{startup_rate_value}$$

The governor increases the engine speed from the engine's crank speed to the active target speed at the rate specified by this parameter.

The ramp up will pause at the STARTUP SPEED until the governor senses an MPU signal greater than the STARTUP SPEED. This prevents the startup ramp from reaching completion before the engine has even started. The governor considers MPU frequencies below the STARTUP SPEED as indicating that the engine is cranking but has not yet started. MPU frequencies above the STARTUP SPEED are taken to indicate that the engine has started and the governor will increase the engine speed until the selected set speed is reached.

Exception: In cases where the target speed is less than the Startup Speed, the startup ramp sequence ends when the target speed is reached.

During the startup sequence the governor increases the engine speed from the engine's crank speed to the active target speed at the STARTUP RATE specified. The active target speed will be the selected set speed, either REMOTE SPEED, SET SPEED A or SET SPEED B, based on the state of the digital inputs. The startup sequence is complete once the engine speed reaches the selected set speed.

NOTE:

When the No. of FLYWHEEL TEETH parameter is used, the ACCEL RATE, DECEL RATE, and STARTUP RATE parameters are displayed as a RPM quantity per second instead of Hz/sec values. The given rate formulas can be used to compute rates in terms of RPM values by substituting the Hertz speed values with RPM speed values.

3.18 Startup Limit

The startup limit parameter is used to limit the fuel supplied to the engine during startup. The default value of 1000 allows the actuator drive signal to use 100.0% of available current. Decreasing the value limits the available drive signal thereby limiting how far open the actuator can go. Increasing the value allows the actuator to open further.

The value assigned to the startup limit parameter is in units of one-tenth of a percent of the actuator's maximum current feedback reading. The governor measures the actuator drive-signal feedback and obtains an approximation of the amperes of current flowing through the actuator. Fuel limiting is achieved by setting the maximum level of electrical current allowed to flow through the actuator during engine startup. This feature is useful in reducing smoke when starting diesel engines.

NOTE: If the value is set too low the engine may not start.

3.19 Torque Limit

The torque limit parameter is used to limit the fuel supplied to the engine during heavy generator loads or generator overloads. The default value of 1000 allows the actuator drive signal to use 100.0% of available current. Decreasing the value limits the available drive signal thereby limiting how far open the actuator can go. Increasing the value allows the actuator to open further.

The value assigned to the torque limit parameter is in units of one-tenth of a percent of the actuator's maximum current feedback reading. The governor measures the actuator drive-signal feedback and obtains an approximation of the amperes of current flowing through the actuator. Fuel limiting is achieved by setting the maximum level of electrical current allowed to flow through the actuator during normal operation.

NOTE: If the value is set too low the engine will not be able to carry its rated load.

3.20 Integral Low Limit

The integral low limit prevents "integral windup" in the negative direction. In other words, the integral low limit parameter is used to reduce underspeed duration after a long or sustained overspeed condition was present. The low limit helps reduce the duration and amount of engine underspeed by maintaining a minimum actuator position.

When smaller PWM duty cycle values do not reduce the engine speed any further but an off speed (measured speed greater than the target speed) remains, letting the Integral term grow more negative is not beneficial. Unused negative integration would cause a slower recovery from an underspeed condition.

The integral low limit specifies the PWM duty cycle where the integrator's influence on lowering PID output must stop. The default value is 0%. The value can be adjusted from 0% to 90% in 1% increments.

CAUTION: Use carefully as improper use can prevent the governor from ever reaching the target speed. The first line of defense in reducing overspeed or underspeed errors is a well-tuned governor via the PID terms.

3.21 Integral High Limit

The integral high limit prevents "integral windup" in the positive direction. In other words, the integral high limit parameter is used to reduce overspeed duration after a long or sustained underspeed condition was present. The high limit helps reduce the duration and amount of engine overspeed by maintaining a maximum actuator position.

When larger PWM duty cycle values do not increase the engine speed any further but a negative off speed (measured speed less than the target speed) remains, letting the Integral term grow more positive is not beneficial. Unused positive integration would cause a slower recovery from an overspeed condition.

If an engine overload situation causes the engine speed to remain below the target speed for some period of time, then the integral portion of PID output would grow larger than otherwise needed (would windup). Therefore, when the load is removed the engine may overspeed because it takes time for the integral portion of PID output to shrink or "unwind." This is where reducing the Integral Limit High value can help by preventing excessive windup in the PID output's integration term.

The integral high limit specifies the PWM duty cycle where the integrator's influence on raising PID output must stop. The default value is 99%. The value can be adjusted from 99% down to 10% in 1% increments.

CAUTION: Use carefully as improper use can prevent the governor from ever reaching the target speed. The first line of defense in reducing overspeed or underspeed errors is a well-tuned governor via the PID terms.

3.22 Password

The password protect parameter is provided to protect against inadvertent parameter changes that may occur whenever the keys are pressed and a parameter modification is not intended. The password protect parameter has three possible settings: DISABLED, LOCKED, and UNLOCKED

DISABLED – This setting turns off any password protection. Use this setting if password protection is not desired. This is the default setting as shipped from the factory. Entering a value of [99] sets the password protect parameter to the disabled mode. When the password protect parameter is selected, the LED display will show [Pd] for 2 seconds, indicating the password-disabled mode, then the value [00.] is displayed. The user can then edit the value.

LOCKED – This setting means that password protection is active and only parameter viewing is allowed (parameter editing is disabled). Enter a value of [22] to set password protect to locked mode. For 2 seconds after selection of the password protect parameter, the LED display will show [PE.] for this mode and the rightmost decimal point will be ON (not blinking), then the value [00.] is displayed. The user can then edit the value.

UNLOCKED – This setting means that password protection is active but parameter editing is allowed. Entering a value of [30] while in LOCKED mode will UNLOCK parameter editing. The user is free to edit parameters. If there is no keypad activity for 5 minutes, the controller returns to LOCKED mode. If not already in the UNLOCKED mode, the user must get into the UNLOCKED mode in order to enter a 99 to disable password protection.

3.23 Overspeed Limit

This parameter is used to determine the engine speed that will trigger the governor to output minimum fuel. The parameter's value is in terms of a percentage over the highest set speed. In other words, an over speed condition is detected if the engine speed reaches a speed of [OVER SPEED LIMIT %] greater than the highest set speed.

For example: If the highest set speed is 1800 RPM and this parameter is set to 20, then an overspeed condition will be detected at 2160 RPM (the value that is 20% greater than 1800). Formula: $1.20 * 1800 \text{ RPM} = 2160 \text{ RPM}$

The default value of 100 is used to disable overspeed detection. Use values less than 100 to enable the overspeed limit function and set the limit speed to $[(1 + (\text{overspeed_limit_value}/100)) * (\text{highest_set_speed})]$.

NOTE: The governor must be turned off to clear the overspeed detection before the engine can be restarted.

3.24 Set Speed A Min

Set Speed A Min is used to set the lowest value allowed for adjustments of Set Speed A. This parameter can be set to any value within the range bordered by 10 Hertz (2 Hertz ignition) and the current value of Set Speed A.

3.25 Set Speed A Max

Set Speed A Max is used to set the highest value allowed for adjustments of Set Speed A. This parameter can be set to any value within the range bordered by current Set Speed A setting and 11,000 Hertz (300 Hertz ignition).

3.26 Set Speed B Min

Set Speed B Min is used to set the lowest value allowed for adjustments of Set Speed B. This parameter can be set to any value within the range bordered by 10 Hertz (2 Hertz ignition) and the current value of Set Speed B.

3.27 Set Speed B Max

Set Speed B Max is used to set the highest value allowed for adjustments of Set Speed B. This parameter can be set to any value within the range bordered by current Set Speed B setting and 11,000 Hertz (300 Hertz ignition).

3.28 Duty Cycle Limit

The Duty Cycle Limit parameter sets the absolute maximum amount of drive signal that can be output to the actuator and thus serves as a mechanism for fuel limiting. Fuel limiting is achieved by setting the maximum duty cycle or ontime allowed during one cycle of the PWM (pulse-width-modulation) signal controlling the actuator drive circuit. The value assigned to the duty cycle limit parameter is a percentage, and is limited to values in the range 10% to 95%. The default value is 95%.

3.29 Input Polarity

The input polarity parameter affects how the DPG-23XX interprets the logic states of the DIG IN A and B inputs.

The default DIG IN A and B logic selection is positive logic. Therefore open DIG IN A and B inputs would generate a zero, zero, pattern. Negative logic would produce a one, one, pattern. This is shown in the table below.

DIG IN A & B MODE SELECT LOGIC	INPUT	LOGIC
0 = Positive logic	Open contact	0
1 = Negative logic	Open contact	1

3.30 E1 Handler Select

This parameter determines how the governor will handle clearing the E1 error. Upon detecting an E1 error condition (Loss of Remote Set Speed Signal), the governor automatically returns to the Remote Speed Min value.

When the value entered is zero, **power must be removed from the governor** to clear the E1 error condition.

When the value entered is one, the E1 error is automatically cleared when the Remote Set Speed Signal returns to the Speed Pot Min or Speed Pot Max position recorded during calibration.

3.31 Startup Speed

The Startup Speed parameter should be set to an engine speed at least 10% higher than the fastest engine cranking speed but lower than the engine's idle speed. This allows the governor to determine whether the engine is cranking or running whenever an engine speed signal is present.

If the Startup Speed value is set too low (less than crank speed) the governor's target speed will be ramped to the active set speed (Remote Speed Pot, Set Speed A, or Set Speed B) before the engine has started. Therefore, when the engine does start, it may overspeed or output excessive smoke because the startup ramp, having already completed, no longer controls the rate of engine speed increase.

If the Startup Speed value is set too high (above the active set speed) then the Startup Speed becomes the target speed that the governor must reach before the governor considers the startup sequence complete. Typically, the startup sequence ends when the engine speed reaches the active set speed. The active set speed is the Remote Speed Pot, Set Speed A, or Set Speed B.

To determine the proper value for this parameter the crank speed must be known. There are two ways to determine the engine crank speed.

- 1) Use a meter to measure the frequency across the MPU+ and MPU- terminals of the governor during cranking or . . .
- 2) Use a PC running the Universal PST application and read the value of the Measured Speed in the View Status panel when the engine is cranking. Note: From the Universal PST's startup screen press the View Status button, then press the Start Monitoring button to begin reading values.

3.32 Startup Duty Cycle

The Startup Duty Cycle parameter is used to pre-load the PID output with a PWM duty cycle value close to that needed for the actuator to allow enough fuel to idle the engine.

If the value is too low, then the engine crank time may be longer than desired because the governor's actuator output starts from a value much smaller than needed to begin opening the fuel valve.

If the value is too high, then the engine may overspeed because the actuator opens more than needed to start the engine.

There are two ways to determine a good value to use for this parameter.

- 1) Use a meter to measure the duty cycle across the ACT terminals of the governor while the engine is running. Note: To determine if your meter is reading the correct value:
 - a. First, apply power to the governor but do NOT start the engine
 - b. Second, measure the duty cycle across the ACT terminals (#3 and #4). The reading should be 5 for 5%. If the reading is 95, then reverse the leads.
- 2) Use a PC running the Universal PST application and read the value of the PWM command in the View Status panel when the engine is cranking. Note: from the Universal PST's startup screen press the View Status button, then press the Start Monitoring button to begin reading values.

3.33 Speed Pot Action

The Speed Pot Action parameter affects how the controller interprets the REMOTE SET SPEED SIG input. When in forward acting mode, as the voltage at the Remote Set Speed Signal input increases the engine speed increases. When in reverse acting mode, as the voltage at the Remote Set Speed Signal input decreases the engine speed increases. This is shown in the table below.

PEDAL ACTION SETTING	REMOTE SET SPEED INPUT VOLTAGE	DIRECTION
0 = Forward Acting	Increase	CW
1 = Reverse Acting	Decrease	CCW

The DPG-23XX-001 defaults to forward acting mode.

Chapter 4. Universal PST

Introduction

The Universal PST is a Microsoft® Windows® application available from Woodward that enables you to adjust parameter settings and monitor governor operation when a PC is connected to the governor through the built-in COMM port.

Features

Universal PST for DPG features include:

- Automatic configuration to each DPG when communications established
- Read/write access to all of a DPG's programmable parameters and features
- Display of each parameter's default, minimum, and maximum values
- Diagnostics utilizing automatic refresh of DPG status
- Saving and reloading DPG setup information to and from a file for reuse
- Single button read to get the current values of all parameters
- Single button write to program a DPG with previously saved setup values
- Engine speed monitoring via a chart recorder to aid in tuning the governor
- Saving chart recorder data to a Microsoft Excel compatible file
- Help information on each of the governor's parameters
- Help information on using the Universal PST

Universal PST Requirements

The program requires an Intel Pentium class machine running Microsoft® Windows® 98se, NT4, 2000, or XP. The display resolution needs to be set to SVGA (800x600) or higher. The Universal PST program is not supported on Microsoft® Windows® 95. The program may work on Microsoft® Windows® ME (Millennium Edition), but this has not been tested.

Acquiring Universal PST

The Universal PST application is available from our website. If you have an Internet connection you can download a copy from www.woodward.com/IC/Software.

What to download: The files *ReadMeFirst.txt*, *Universal_PST.zip*, and *Universal_PST_mdb_Update.zip* are available for download on the Software Products page at the www.woodward.com/IC/Software website.

Requesting the Universal PST on CD-ROM: If you do not have an Internet connection, or have problems downloading the large zip file, contact the Woodward sales department to request a CD-ROM copy of Universal PST for a nominal charge. Telephone: (847) 967-7730.

Wiring the COMM Port to a PC

RJ11 OR RJ12 POSITION	DPG-2200 SIGNAL	CONNECTS TO:
1	No connection	
2	Transmit data to PC	PC receive (RxD) DB9 pin 2
3	Receive data from PC	PC transmit (TxD) DB9 pin 3
4	COMMON	PC common DB9 pin 5
5	+5 Vdc (Do NOT connect at the PC end)	
6	No connection	

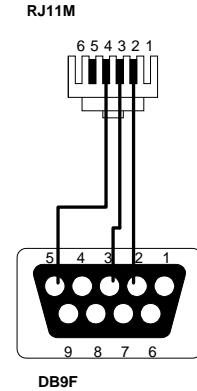

DESCRIPTION	MALE	FEMALE
RJ11 *		This is the connector provided on the DPG-2200 controllers.
RJ12		
DB9	This is the connector typically provided on a PC for the RS232 serial port. 	

(*) An RJ11 is the same physical size and fit as an RJ12 but provides conductors only in the center 4 positions.

Chapter 5

Calibration Instructions

Basic Adjustments

The controller is programmed at the factory with default parameter settings. These settings allow the controller to operate but usually require some further adjustments to obtain the best system performance. In order to bring the engine up to a single speed for the first time, the installer will need to adjust the parameters shown in the table and install a switch or jumper between DIG IN A (terminal 11 and +5 Vdc (terminal 13). DIG IN B is OPEN.

The parameters listed are the primary ones to modify to get the governor tuned and the engine running smoothly. It is recommended that you work with them first and leave all the other parameters at their default values until you are satisfied with the basic engine tuning.

ID#	Parameter Name	Default Value
4	SET SPEED A	1000
6	PROPORTIONAL	25
7	INTEGRAL	50
8	DERIVATIVE	25
11	OVG @ SET SPEED A	20
13	GAIN FACTOR (note 1)	20
14	SPEED FILTER (note 2)	16

NOTE 1: Modify Gain Factor only if you run out of adjustment in a PID or OVG term.

NOTE 2: For the Speed Filter, typically the value 24 works well on small 3- or 4-cylinder engines. A value of 16 is recommended for 6- or 8-cylinder engines.

Tuning Methodology

Once the engine is running, the following procedure may be used to discover more optimum values for PID and the overall gain parameters (OVG). The goal would be to find PID values that allow the controller to govern the engine well at a variety of different speeds and loads while only requiring gain adjustment at those different speeds.

Follow these steps:

1. Set the integral and derivative terms to 0.
2. Set the overall gain low (<20).
3. Increase the proportional term until you get continuous oscillations greater than 2Hz.
4. Reduce the proportional term by 25% to 50%.
5. Now experiment with small value changes in the derivative to dampen out "ringing" in response to load transients.

6. Add some integral to eliminate any steady-state error in the engine's speed and help decrease error recovery time.
7. The overall gain can be increased to improve response time while keeping the ratios of the PID terms relative to each other constant.

During each of the steps 3 through 6, you need to disturb the system by adding and removing a load from the engine to check the governor's response to the load transition. **START WITH SMALL LOADS.**

Note that without integral, a speed error may persist after a load-on load-off transition. Therefore, during steps 3-5 you should temporarily increase the integral to get the engine speed back to the set speed, and then reset the integral to a lower value again while working to find good proportional and derivative values. Repeat steps 3-7 as needed to find a Proportional value, Integral value, and a Derivative value that work well with a variety of overall gain values and different load transients.

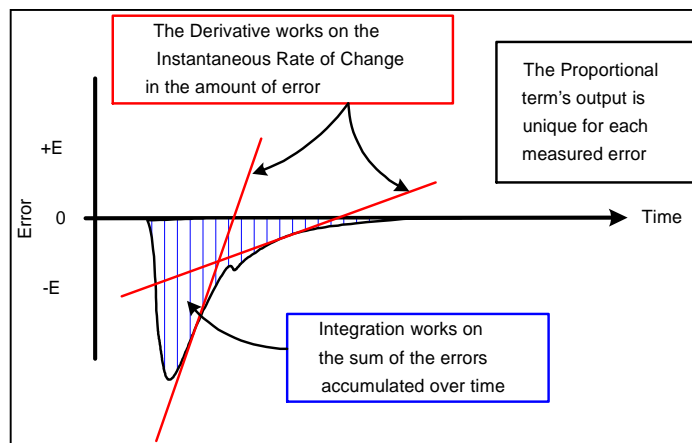

Remote Speed Potentiometer Calibration Procedure

To use a Remote Speed Pot, a calibration sequence *must* be done first, as follows:

Step 1	Connect a potentiometer to the governor. Refer to wiring diagram in chapter 6.
Step 2	Make sure the engine is NOT running and the Remote Speed Pot is selected to set the target speed (DIG IN A and B inputs are open).
Step 3	Adjust the speed pot to the desired counterclockwise (CCW) position.
Step 4	Enter a value of 69 into the Password parameter (22) to enable the speed pot calibration. The LED will display C0 to indicate that calibration mode is active.
Step 5	Adjust the speed pot to the desired clockwise (CW) position and back to the counterclockwise (CCW) position.
Step 6	Press the controller's ENTER key to record the calibration values. Remote speed pot calibration is complete.

After calibration, the governor uses the learned range to compute the speed potentiometer's actual position over the speed range defined by the Remote Speed Min and Remote Speed Max parameters.

Chapter 6. Installation Instructions

The APECS controller is designed to be panel mounted, in a location that protects it from exposure to rain, weather, and direct sunlight. The controller should not be mounted on the engine or in an environment that exceeds the mechanical specifications outlined in Chapter 2. It should be mounted in a position to allow access to the user interface, the COMM port and the terminal strip.

DPG 2302-001 Terminal Descriptions

NO.	NAME	FUNCTION
1	BAT+	Battery positive (Supply voltage range is 9 Vdc-30 Vdc)
2	BAT-	Battery negative
3	ACT	Actuator drive output
4	ACT	Actuator drive return
5	MPU+	Magnetic pickup signal inputs
6	MPU-	Magnetic pickup ground
7	SHIELD	Ground connection for cable shielding
8	Remote Speed Pot COM	Common for the remote speed pot CCW
9	Remote Speed Pot SIG	Remote Speed Signal Input (Input Range 0.20 Vdc-4.80 Vdc)
10	Remote Speed Pot +5 V	Supply voltage for the remote speed pot CW
11	DIG IN A	Mode select input A
12	DIG IN B	Mode select input B
13	+5 Vdc	Supply voltage for DIG IN A & DIG IN B inputs

DPG 2302-001 Wiring Diagram

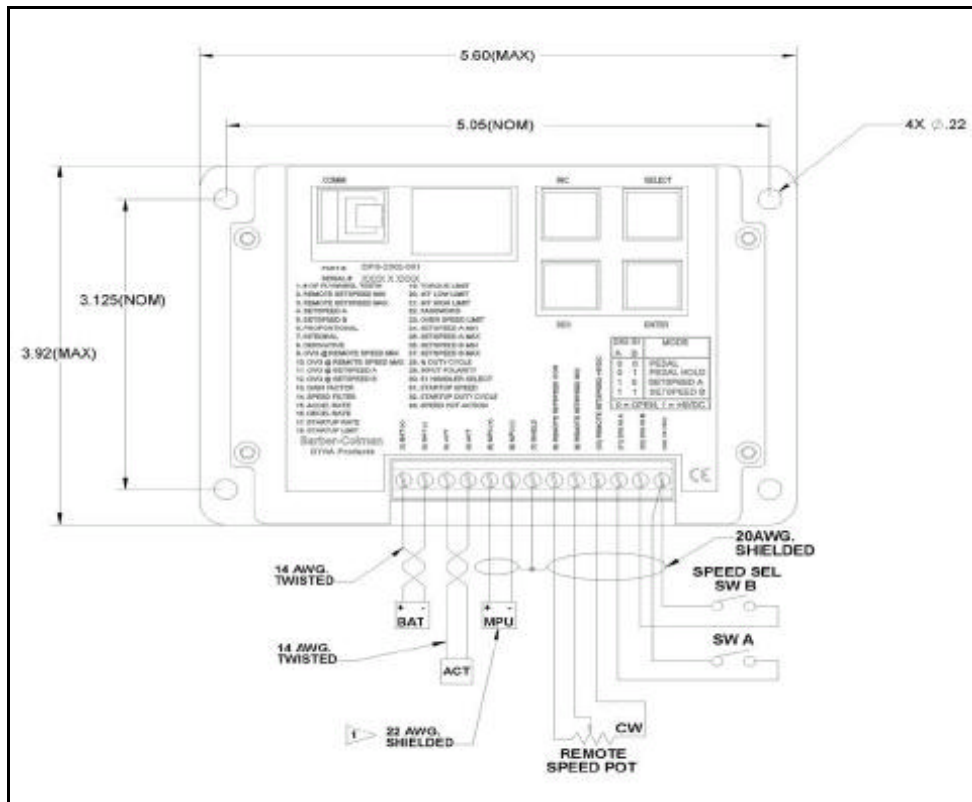

DPG 2345-001 Terminal Descriptions

NO.	NAME	FUNCTION
1	BAT+	Battery positive (Supply voltage range is 9 Vdc-30 Vdc)
2	BAT-	Battery negative
3	ACT	Actuator drive output
4	ACT	Actuator drive return
5	IGN+	Ignition tach
6	IGN-	Ignition ground
7	SHIELD	Ground connection for cable shielding
8	Remote Speed Pot COM	Common for the remote speed pot CCW
9	Remote Speed Pot SIG	Remote Speed Signal Input (Input Range 0.20 Vdc-4.80 Vdc)
10	Remote Speed Pot +5 V	Supply voltage for the remote speed pot CW
11	DIG IN A	Mode select input A
12	DIG IN B	Mode select input B
13	+5 Vdc	Supply voltage for DIG IN A & DIG IN B inputs

DPG 2345-001 Wiring Diagram

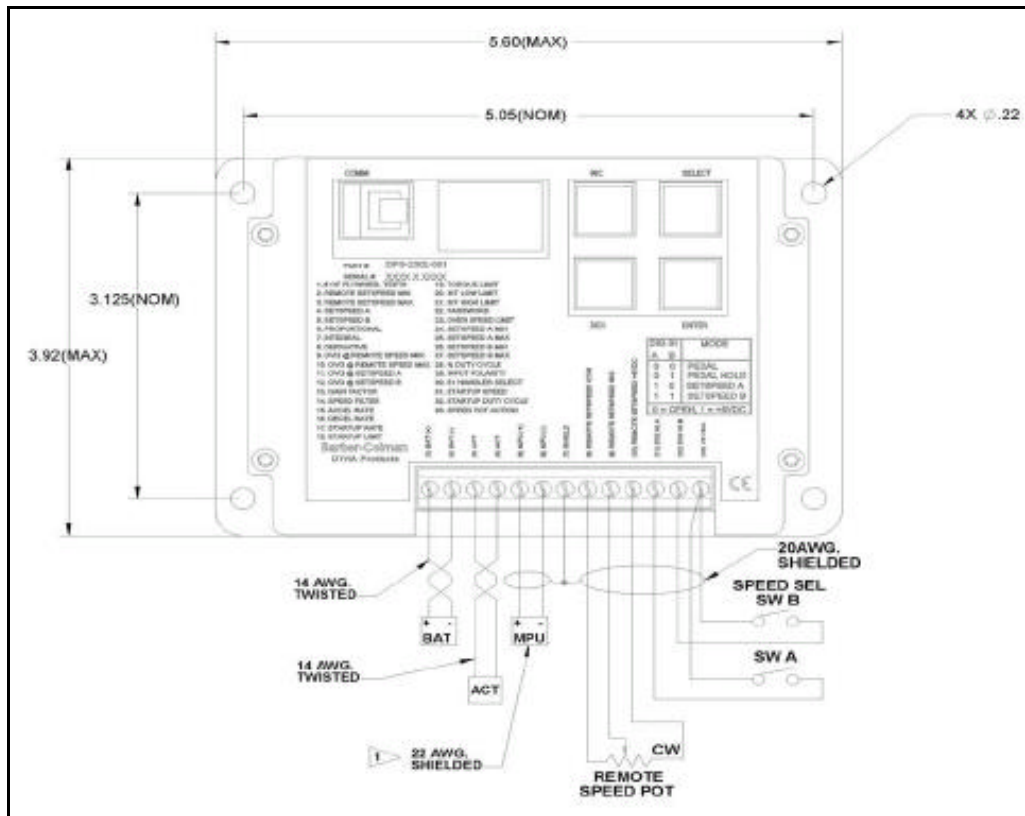

Mode Selection

The following examples show the proper wiring configurations for selecting each of the available speed operating modes.

While in PEDAL mode, the controller will track the remote speed input and command the engine to run between the REMOTE SET SPEED MIN and REMOTE SET SPEED MAX speed range.

DIG IN		MODE
A	B	
0	0	Pedal
0	1	Pedal Hold
1	0	Set Speed A
1	1	Set Speed B

While in PEDAL HOLD mode, the controller will command the engine to run at the current PEDAL or REMOTE SPEED INPUT. The controller will lock this request and not accept any new requests while in PEDAL HOLD.

While in SET SPEED A mode, the controller will command the engine to run at the SET SPEED A set speed. The controller will not respond to any REMOTE SPEED INPUT changes.

While in SET SPEED B mode, the controller will command the engine to run at the SET SPEED B set speed. The controller will not respond to any REMOTE SPEED INPUT changes.

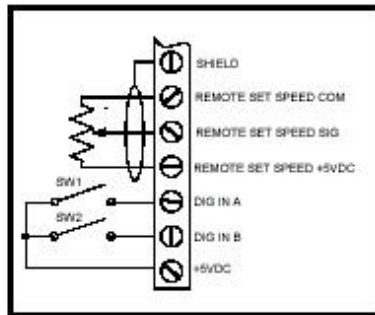

Pedal

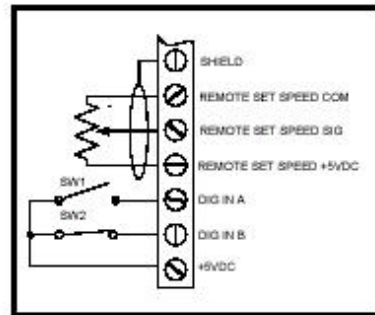

Pedal Hold

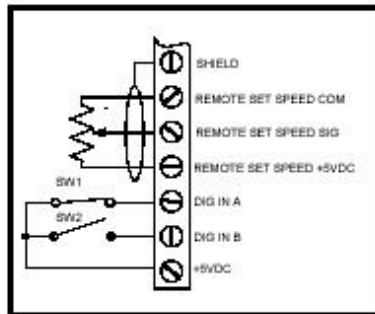

Set Speed A

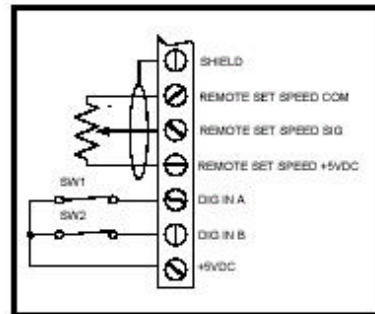

Set Speed B

Preferred Wiring for Cruise Control

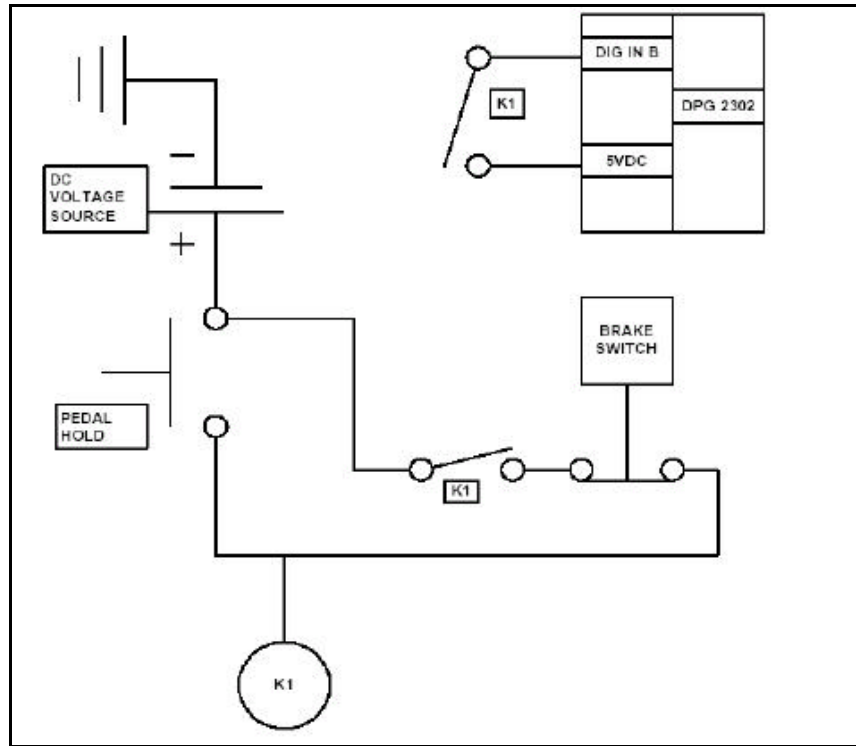

Chapter 7

Diagnostics & Troubleshooting

Display Codes

CODE	MEANING
E0	Controller memory failure. Replace controller.
E1	Loss of remote speed potentiometer signal. (Applies only to DPG-2302-001 and DPG-2401-001 units)
E2	Overspeed detected. Controller must be turned off and reset to allow an engine restart.
E3	Actuator drive overcurrent detected. Check wiring. Check actuator loading.

Troubleshooting Table

SYMPTOM	REMEDY
LED Display Does Not Light Up When Governor Is Powered	BAT + and BAT – leads are reversed. Check wiring. Battery voltage too low. Should measure between 9 and 30 VDC Controller is defective. Replace it.
Unable to Modify Parameters	The parameter's value is the maximum value allowed. The parameter's value is the minimum value allowed. A display code is active. Refer to the Display Codes section above Password protection is enabled. Enter Password Keypad failure, replace unit.
Engine Does Not Start	Actuator leads not connected or shorted. No fuel source. Turn on fuel source. Battery voltage is low. Charge or replace the battery. Set speed is lower than crank speed. Increase the set speed. Startup Rate setting is too low. The target speed ramps up too slow. Startup Limit is too low, limiting the actuator drive signal too much. Is the MPU speed signal present? It should read 2.0 VRMS minimum. Adjust magnetic pickup (MPU) gap. Try reversing the MPU leads. If a speed signal is present, measure actuator output duty cycle. If not greater than 5%, then restore all parameter values to factory default settings and crank the engine again.
Engine Overspeeds at Startup	Increase the Proportional value. Increase the appropriate OVG (overall gain) value. Use the Startup Limit. Decrease the Startup Ramp Rate.
Engine Does Not Reach Set Speed	Improve PID tuning. Integral too low or zero Derivative too low or zero PID values are too low. A tuning that is too soft can prevent the governor from delivering the needed actuator drive signal to reach the set speed.

Engine Does Not Reach Set Speed (cont'd.)	<p>PID values are too high. Tuning is too hot or oversensitive to small speed errors, which causes the governor to make large, rapid changes in actuator drive signal, creating an average signal that is inadequate.</p> <p>Integral Low Limit setting is too high. Return the value to default setting of zero.</p> <p>Integral High Limit setting is too low. Return the value to default setting of 99.</p>
Engine Takes Too Long to Reach the Set Speed	<p>Improve PID tuning.</p> <p>Integral setting is too low.</p> <p>Startup Rate setting is too low.</p> <p>Accel Rate setting is too low.</p> <p>Speed Filter setting is too high.</p>
Engine Does Not Track Speed Setting Changes	<p>Is the LED decimal point blinking? If not, enter password.</p> <p>Is the selected set speed parameter being modified?</p> <p>A PID value or an OVG value is too high.</p> <p>A PID value is too low or zero.</p> <p>Accel Rate is set too low.</p> <p>Decel Rate is set too low.</p>
Excessive Smoke at Startup	<p>Improve PID tuning.</p> <p>Use a lower Startup Rate setting.</p> <p>Use a lower Startup Limit setting.</p> <p>Low MPU signal voltage. It should read 2.0 VRMS minimum.</p>
Sluggish Response to Load Changes	<p>Gain too low.</p> <p>Improve PID tuning.</p> <p>Speed filter setting is too high.</p>
Engine Instability With No Load	<p>Improve PID tuning.</p> <p>Speed filter setting is too low.</p> <p>Fuel is restricted. Check actuator linkage.</p> <p>Battery voltage is too low.</p>
Engine Instability With Load	<p>Improve PID tuning.</p> <p>Fuel is restricted. Check actuator linkage.</p> <p>Battery voltage is too low.</p>
Engine Unable to Carry Rated Load	<p>PID values may be too high, causing the governor to overreact and make large, rapid changes in PWM duty cycle output to the actuator.</p> <p>Improve PID tuning.</p> <p>Torque limit is set too low. Increase the torque limit.</p> <p>Fuel is restricted. Check actuator linkage.</p>
Load Sharing Does Not Work	<p>Not available on DPG-23XX-001.</p> <p>Measure the ILS input signal to see if the measurement is between 2.375 and 2.625 Vdc.</p> <p>Use shielded wiring.</p> <p>If application requires more than $\pm 3\%$ of speed change around the set speed, use a DPG-2401-001 controller.</p>
Dropout Does Not Work	<p>Not available on DPG-23XX-001.</p> <p>The No Load and Full Load values are not calibrated. Perform the Droop Calibration Procedure.</p> <p>Difference between No Load and Full Load calibration values is too small. Should be > 100 for best performance.</p> <p>Modify or adjust actuator linkage to increase range of actuator loading.</p> <p>If finer droop control is required, use a DPG-2401-001 controller.</p>

Chapter 8.

Service Options

Product Service Options

The following factory options are available for servicing Woodward equipment, based on the standard Woodward Product and Service Warranty (5-01-1205) that is in effect at the time the product is purchased from Woodward or the service is performed:

- Replacement/Exchange (24-hour service)
- Flat Rate Repair
- Flat Rate Remanufacture

If you are experiencing problems with installation or unsatisfactory performance of an installed system, the following options are available:

- Consult the troubleshooting guide in the manual.
- Contact Woodward technical assistance (see “How to Contact Woodward” later in this chapter) and discuss your problem. In most cases, your problem can be resolved over the phone. If not, you can select which course of action you wish to pursue based on the available services listed in this section.

Replacement/Exchange

Replacement/Exchange is a premium program designed for the user who is in need of immediate service. It allows you to request and receive a like-new replacement unit in minimum time (usually within 24 hours of the request), providing a suitable unit is available at the time of the request, thereby minimizing costly downtime. This is also a flat rate structured program and includes the full standard Woodward product warranty (Woodward Product and Service Warranty 5-01-1205).

This option allows you to call in the event of an unexpected outage, or in advance of a scheduled outage, to request a replacement control unit. If the unit is available at the time of the call, it can usually be shipped out within 24 hours. You replace your field control unit with the like-new replacement and return the field unit to the Woodward facility as explained below (see “Returning Equipment for Repair” later in this chapter).

Charges for the Replacement/Exchange service are based on a flat rate plus shipping expenses. You are invoiced the flat rate replacement/exchange charge plus a core charge at the time the replacement unit is shipped. If the core (field unit) is returned to Woodward within 60 days, Woodward will issue a credit for the core charge. [The core charge is the average difference between the flat rate replacement/exchange charge and the current list price of a new unit.]

Return Shipment Authorization Label. To ensure prompt receipt of the core, and avoid additional charges, the package must be properly marked. A return authorization label is included with every Replacement/Exchange unit that leaves Woodward. The core should be repackaged and the return authorization label affixed to the outside of the package. Without the authorization label, receipt of the returned core could be delayed and cause additional charges to be applied.

Flat Rate Repair

Flat Rate Repair is available for the majority of standard products in the field. This program offers you repair service for your products with the advantage of knowing in advance what the cost will be. All repair work carries the standard Woodward service warranty (Woodward Product and Service Warranty 5-01-1205) on replaced parts and labor.

Flat Rate Remanufacture

Flat Rate Remanufacture is very similar to the Flat Rate Repair option with the exception that the unit will be returned to you in “like-new” condition and carry with it the full standard Woodward product warranty (Woodward Product and Service Warranty 5-01-1205). This option is applicable to mechanical products only.

Returning Equipment for Repair

If a control (or any part of an electronic control) is to be returned to Woodward for repair, please contact Woodward in advance to obtain a Return Authorization Number. When shipping the item(s), attach a tag with the following information:

- name and location where the control is installed;
- name and phone number of contact person;
- complete Woodward part number(s) and serial number(s);
- description of the problem;
- instructions describing the desired type of repair.



CAUTION

To prevent damage to electronic components caused by improper handling, read and observe the precautions in Woodward manual 82715, *Guide for Handling and Protection of Electronic Controls, Printed Circuit Boards, and Modules*.

Packing a Control

Use the following materials when returning a complete control:

- protective caps on any connectors;
- antistatic protective bags on all electronic modules;
- packing materials that will not damage the surface of the unit;
- at least 4 inches (100 mm) of tightly packed, industry-approved packing material;
- a packing carton with double walls;
- a strong tape around the outside of the carton for increased strength.

Return Authorization Number

When returning equipment to Woodward, please telephone and ask for the Customer Service Department [1 (800) 523-2831 in North America or +1 (970) 482-5811]. They will help expedite the processing of your order through our distributors or local service facility. To expedite the repair process, contact Woodward in advance to obtain a Return Authorization Number, and arrange for issue of a purchase order for the item(s) to be repaired. No work can be started until a purchase order is received.



NOTE

We highly recommend that you make arrangement in advance for return shipments. Contact a Woodward customer service representative at 1 (800) 523-2831 in North America or +1 (970) 482-5811 for instructions and for a Return Authorization Number.

Replacement Parts

When ordering replacement parts for controls, include the following information:

- the part number(s) (XXXX-XXXX) that is on the enclosure nameplate;
- the unit serial number, which is also on the nameplate.

How to Contact Woodward

In North America use the following address when shipping or corresponding:

Woodward Governor Company
PO Box 1519
1000 East Drake Rd
Fort Collins CO 80522-1519, USA

Telephone—+1 (970) 482-5811 (24 hours a day)
Toll-free Phone (in North America)—1 (800) 523-2831
Fax—+1 (970) 498-3058

For assistance outside North America, call one of the following international Woodward facilities to obtain the address and phone number of the facility nearest your location where you will be able to get information and service.

<u>Facility</u>	<u>Phone Number</u>
Brazil	+55 (19) 3708 4800
India	+91 (129) 230 7111
Japan	+81 (476) 93-4661
The Netherlands	+31 (23) 5661111

You can also contact the Woodward Customer Service Department or consult our worldwide directory on Woodward's website (www.woodward.com) for the name of your nearest Woodward distributor or service facility. [For worldwide directory information, go to www.woodward.com/ic/locations.]

Engineering Services

Woodward Industrial Controls Engineering Services offers the following after-sales support for Woodward products. For these services, you can contact us by telephone, by email, or through the Woodward website.

- Technical Support
- Product Training
- Field Service

Contact information:

Telephone—+1 (970) 482-5811

Toll-free Phone (in North America)—1 (800) 523-2831

Email—icinfo@woodward.com

Website—www.woodward.com/ic

Technical Support is available through our many worldwide locations or our authorized distributors, depending upon the product. This service can assist you with technical questions or problem solving during normal business hours. Emergency assistance is also available during non-business hours by phoning our toll-free number and stating the urgency of your problem. For technical support, please contact us via telephone, email us, or use our website and reference **Customer Services** and then **Technical Support**.

Product Training is available at many of our worldwide locations (standard classes). We also offer customized classes, which can be tailored to your needs and can be held at one of our locations or at your site. This training, conducted by experienced personnel, will assure that you will be able to maintain system reliability and availability. For information concerning training, please contact us via telephone, email us, or use our website and reference **Customer Services** and then **Product Training**.

Field Service engineering on-site support is available, depending on the product and location, from one of our many worldwide locations or from one of our authorized distributors. The field engineers are experienced both on Woodward products as well as on much of the non-Woodward equipment with which our products interface. For field service engineering assistance, please contact us via telephone, email us, or use our website and reference **Customer Services** and then **Technical Support**.

Technical Assistance

If you need to telephone for technical assistance, you will need to provide the following information. Please write it down here before phoning:

General

Your Name _____

Site Location _____

Phone Number _____

Fax Number _____

Prime Mover Information

Engine/Turbine Model Number _____

Manufacturer _____

Number of Cylinders (if applicable) _____

Type of Fuel (gas, gaseous, steam, etc) _____

Rating _____

Application _____

Control/Governor Information

Please list all Woodward governors, actuators, and electronic controls in your system:

Woodward Part Number and Revision Letter _____

Control Description or Governor Type _____

Serial Number _____

Woodward Part Number and Revision Letter _____

Control Description or Governor Type _____

Serial Number _____

Woodward Part Number and Revision Letter _____

Control Description or Governor Type _____

Serial Number _____

If you have an electronic or programmable control, please have the adjustment setting positions or the menu settings written down and with you at the time of the call.

We appreciate your comments about the content of our publications.

Send comments to: icinfo@woodward.com

Please include the manual number from the front cover of this publication.



PO Box 1519, Fort Collins CO 80522-1519, USA
1000 East Drake Road, Fort Collins CO 80525, USA
Phone +1 (970) 482-5811 • Fax +1 (970) 498-3058

Email and Website—www.woodward.com

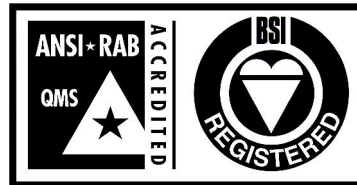

FM 57982
BS EN ISO 9001:1994
6 March 2001

Woodward has company-owned plants, subsidiaries, and branches,
as well as authorized distributors and other authorized service and sales facilities throughout the world.

Complete address / phone / fax / email information for all locations is available on our website.