



WOODWARD

PRODUCT CATALOG 2004

SOLENOIDS | ACTUATORS | ENGINE CONTROLS

ELECTROMAGNETIC CONTROLS AND SYSTEMS



The diesel and gas engine industry
worldwide is changing...and so are we.



WOODWARD

Over the past 70 years you've known us as Synchro-Start Products, but in May 2003 we became Woodward. With the resulting expansion in product lines, increased ability to provide *customized system solutions*, and strong quality and service initiatives, we are prepared to *meet emerging trends* in the global marketplace head on.

Those trends include:

- Strict adherence to tightening emission standards (especially for small engines)
- Consolidation among engine manufacturers
- Increased reliance upon suppliers to offset the high cost of meeting the next generation emission levels.

Woodward's *extensive line of on-engine control and fuel systems* can help you maximize fuel economy, efficiency, and emissions control and minimize your system costs. Moreover, using a consultative approach, Woodward teams understand *each customer's unique challenges* and deliver tightly integrated control systems for unmatched performance in engines of all sizes.

So, whether you're looking for reliable engine control components such as solenoids, sensors, and electronic controls, or fully integrated control systems – intelligent "Networked Engines" – *look to us.*

 **WOODWARD**

The world's leading independent
supplier of energy control
solutions for engines, turbines,
and power equipment.



SOLENOIDS PAGE 02-29

Internally and externally switched solenoids for continuous duty operation in the most severe engine environments

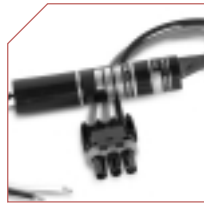

SOLENOID ACCESSORIES PAGE 30-41

Timer modules to prevent overheating of pull coil during long crank time



SOLENOID SHUTDOWN KITS PAGE 42-51

Fit a wide range of engines and fuel injection pump governors for running and stopping engines under all conditions



ELECTRONIC SPEED SWITCHES PAGE 52-63

Electronic speed switches for monitoring and controlling critical speed functions



SPEED SENSORS PAGE 64-69

Signal generators to measure engine speed and magnetic pickups for voltage conversion



APECS® BASICS & CONTROLLERS PAGE 70-83

Advanced Proportional Engine Control System governs engine speed and is computer calibrated using all-digital electronic technology



APECS® PROPORTIONAL ACTUATORS PAGE 84-95

Infinitely variable, step-less motion control



APECS® ACTUATOR KITS PAGE 96-99

Actuators and linkages precision-fitted to maintain isochronous engine speed on specific engines



APECS® ACTUATOR ACCESSORIES PAGE 100-101

Linkage components to ensure stable and responsive engine performance

TABLE OF CONTENTS

Solenoid Basics

From operating engine run/stop levers, throttles, chokes, valves and clutches to protecting expensive diesel engines from over-speed, low lube pressure and high temperature, you can rely on Woodward solenoids to meet the ever-changing technical demands of modern industry.



The Basic Single Coil Solenoid

A solenoid is a device that converts electrical energy into mechanical work. Solenoids are made up of a free moving steel plunger that sits within a wound coil of copper wire. When electric current is introduced, a magnetic field forms, which draws the plunger in. The exposed end of the plunger can be attached to equipment, and when the solenoid is activated, the plunger will move to open, close, turn on or turn off that equipment.

The Woodward Dual Coil Solenoid

To allow a solenoid to be held energized for long periods of time without overheating, Woodward uses two separate coil windings instead of one. The first wound coil operates at a high current level to provide maximum pull or push. The second wound coil simply holds the plunger in place after it has completed its stroke and "bottomed out." Since the current required to hold the plunger in place is low, dual coil solenoids can be energized continuously without overheating. This unique design concept results in a highly efficient compact solenoid approximately one half the size of a comparable single coil unit.

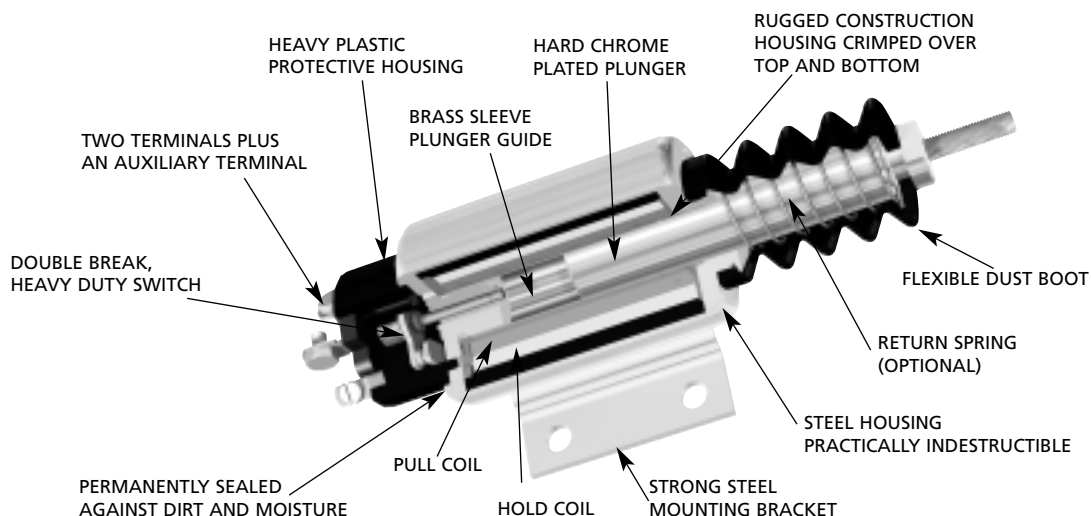

Three methods for turning off the pull coil

After energizing and pulling in the plunger, the pull coil in a dual coil solenoid must be turned off as soon as possible to prevent overheating. The three basic methods for switching off the pull coil are discussed below.

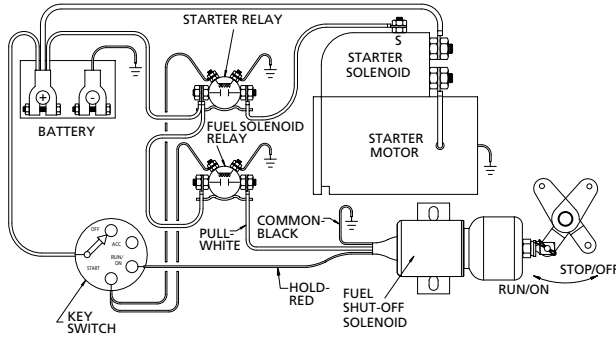

External Switching

The externally switched (3-wire) solenoid is used in applications where an operator/driver manually turns a key switch that temporarily energizes the pull coil to pull in the plunger. The most popular application is for start-stop control of engines in trucks and mobile equipment where moisture, dirt, dust, and high vibration are present. The sealed 3-wire solenoid is well suited for these harsh conditions.

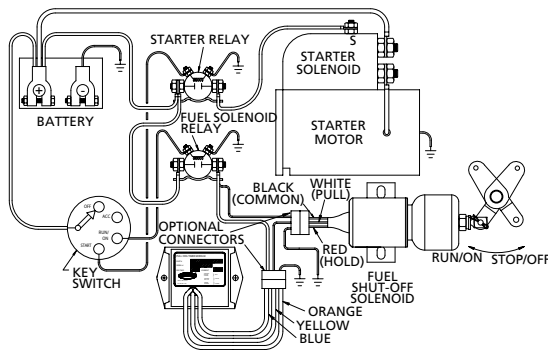

External Switching with Timer Module

With the addition of a Woodward pull coil timer module, the externally switched (3-wire) solenoid can be used not only in operator/driver controlled vehicles, but also in unattended equipment, throttle, and choke controls. The timer ensures that the pull coil is turned off within approximately 1 1/2 seconds after energizing, which prevents overheating of the coil in situations such as abusive overcranking of an engine.

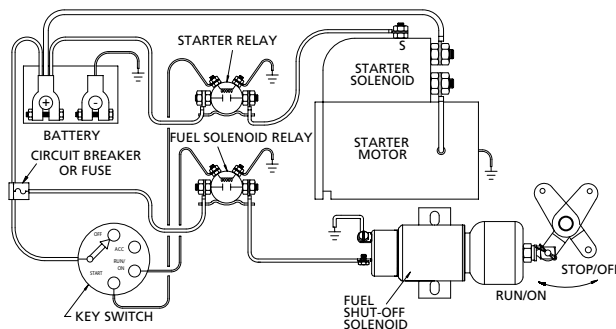

Internal Switching

The internally switched solenoid utilizes a mechanical double contact switch, mounted on the rear of the solenoid, to turn off the pull coil. Best suited for applications such as standby generator sets or other applications where vibration, dirt, moisture, and excessive cycling are not present.

Basics

Solenoid Selection Factors

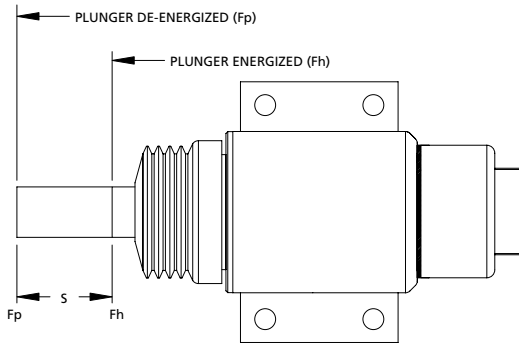

- The pull or push force (F_p) required to move the plunger and load from a de-energized or non-voltage position to an energized or voltage induced position.
- The force required to hold (F_h) the plunger and load in its energized or voltage induced position.
- The total distance or stroke (S) the plunger travels when the solenoid is energized.
- All solenoids are affected by temperature. The hotter the solenoid, the less work it can do because of changes in the resistance of the copper coil wire.
- Low voltage also reduces the solenoid's work output.

Evaluating Solenoid Suitability

To evaluate a solenoid's work output, use the accompanying "pull vs. stroke," "voltage" and "temperature" graphs and follow this example:

Let's assume your application requires a maximum pull force of 7 pounds at a 1 inch stroke. After looking at the "pull vs. stroke" graph, the solenoid you're considering (Model 1502) has a 9 pound pull force at 1 inch stroke. We'll represent this pull force with the letters (F_o). You know the solenoid is operating at 100% of rated voltage. A quick look at the voltage correction graph, which corrects for any extreme voltages, provides a 1.0 factor. We'll represent the voltage correction factor with the letters (f_v). Your solenoid is located near the engine; therefore, the ambient temperature of 122°F (50°C) exceeds the normal 77°F (25°C) ambient. The temperature correction graph indicates a correction factor of .83 be used. We'll indicate the temperature correction factor with the letters (f_t).

Using the formula: $F = F_o \times f_v \times f_t$ or $F = 9 \times 1.0 \times .83 = 7.47$ lbs

Since the available solenoid force of 7.47 pounds is greater than your required pull force of 7 pounds, the solenoid is suitable for this particular application.

Measurements for above factors must be taken in operating conditions. For example: you must start the engine and measure the force to move the lever to the stop position. The engine governor often exerts force on the stop lever, which is not apparent on a stationary engine.

Solenoid Deration Graphs

Pull vs Stroke

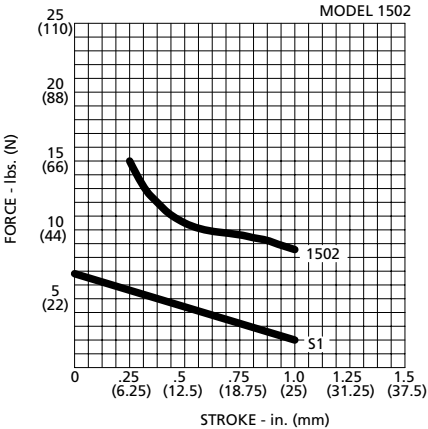

Voltage Correction (fv)

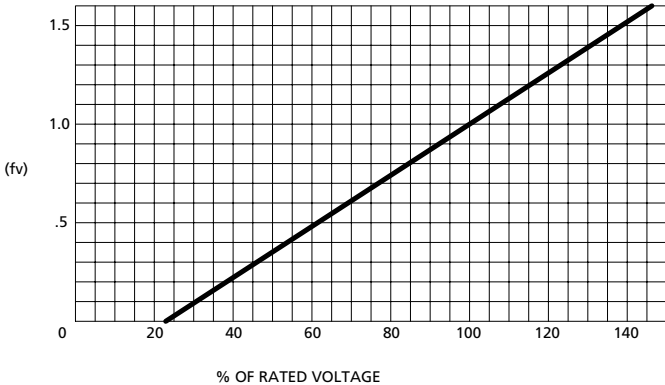

Temperature Correction (ft)

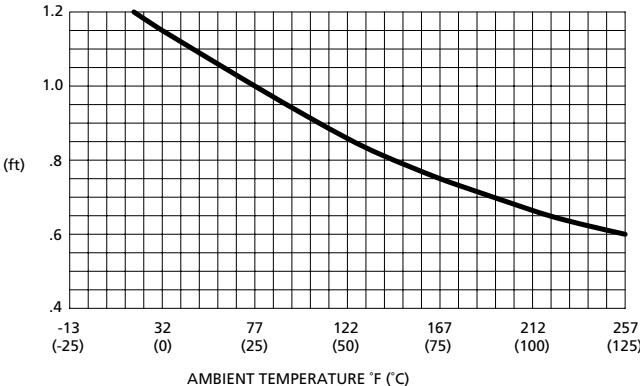

Return Spring Deration

In some cases, an optional spring is attached to ensure that the solenoid’s de-energized plunger returns to its original position. For these applications, when using the “ $F = F_o \times f_v \times f_t$ ” formula to determine the appropriate solenoid, remember: As the “pull vs. stroke” graph illustrates, the addition of a return spring changes the force (F_o) characteristics. When determining (F_o) for a solenoid with a return spring, refer to the appropriate line on the graph illustrating the return spring value (S1).

This value must be subtracted from the solenoid performance curve to assure adequate force is available under derated conditions. Using our original example, the solenoid pull force (F_o) for Model 1502 at full voltage, 122 °F (50 °C) and 1 inch stroke was calculated to be 7.47 lbs. This force must now be reduced by the 2 pounds required to begin compressing the optional return spring (S1) at one inch (see “Pull vs. Stroke” above). The available force has dropped to 5.47 lbs, far below the required 7 pounds for this application. Therefore, a solenoid model with a higher force rating such as the 1504 or 1753 would be required.

Basics

Solenoid Mounting

| | |
|--------------------------|---|
| Location | Although the solenoid is designed to operate in harsh environments, locations with excessive heat build-up and constant exposure to liquid and particulate contaminants should be avoided. |
| Brackets | Must be sufficiently strong to handle solenoid pull forces, vibration and shock inherent in the application. |
| Alignment | The solenoid should be mounted to permit the plunger to be linked in a direct line to the load. Misalignment causes side loading and resulting friction reduces the solenoid's available force. Increasing the distance between the solenoid and the lever-actuating mechanism will reduce the force lost due to side loading friction. |
| Solenoid position | The solenoid should be oriented with the plunger pointed vertically down or at some downward angle. If the plunger is pointed up, contaminants may collect in the plunger bore, affecting long term operation. |

Solenoid Linkage

The connecting link between the solenoid and its intended application is known as the solenoid linkage. For the internal switch to automatically disconnect the high current pull coil, solenoid linkage systems must allow the plunger to move completely into the solenoid body and "bottom out" without binding. Failure to "bottom out" will cause an internally switched solenoid to burn out and an externally switched solenoid to "drop out." Solenoid linkage can take several forms: A rod threaded at both ends, a bead chain, a cable, etc.

| | |
|----------------------------|--|
| Rod | When a connecting rod is employed, the stroke is adjusted by turning the rod on its threads and locking the rod in place with a lock washer and nut. The solenoid should be energized during adjustment. A swivel joint should be incorporated with this type of linkage system to compensate for possible misalignment between the connecting rod and solenoid plunger. |
| Bead chain or cable | When linkage is in either of these forms, the solenoid should be energized and the bead chain or cable length adjusted to give the desired lever position. |
| Plunger travel | Plunger travel must be checked, especially when a bead chain or cable is used in a connecting device. The plunger travel must be limited to the solenoid's rated stroke when it is de-energized. An "L" bracket can be used to limit the plunger travel. (See diagram below.) |

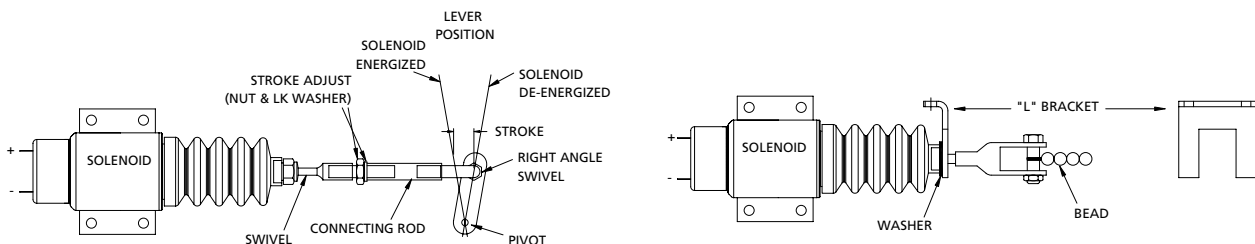

Solenoid Voltage

To minimize voltage loss and resulting solenoid force deration, this chart should be used to select the proper wire thickness based upon the total wire length from the battery to the solenoid and back to the battery.

| | Solenoid Series 1502/1753/1757 | | Solenoid Series 1504/1751/1756/2001 | | Solenoid Series 2003/2370 | |
|---------------------------------|-----------------------------------|---------------|--|--------------|------------------------------|-------------|
| | Wire Length | | Wire Length | | Wire Length | |
| Voltage | 12 VDC | 24 VDC | 12 VDC | 24 VDC | 12 VDC | 24 VDC |
| Wire Thickness | | | | | | |
| 16 gauge or 1.5 mm ² | - | - | - | 21' (6.4 m) | - | - |
| 14 gauge or 2.5 mm ² | 12' (3.7 m) | 40' (12.2 m) | 9' (2.7 m) | 34' (10.4 m) | 5' (1.5 m) | 9' (2.7 m) |
| 12 gauge or 4.0 mm ² | 19' (5.8 m) | 64' (19.5 m) | 14' (4.3 m) | 54' (16.5 m) | 9' (2.7 m) | 14' (4.3 m) |
| 10 gauge or 6.0 mm ² | 20' (6.1 m) | 102' (31.1 m) | 23' (7 m) | 86' (26.2 m) | 14' (4.3 m) | 23' (7 m) |

Solenoid Current

To protect solenoids from permanent overload damage, a well-designed system will include an overload protection device. This chart indicates proper fuse and circuit breaker ratings to incorporate into the wiring system.

| | Solenoid Series 1502/1753/1757 | | Solenoid Series 1504/1751/1756/2001 | | Solenoid Series 2003/2370 | |
|-------------------------|-----------------------------------|--------|--|--------|------------------------------|--------|
| | 12 VDC | 24 VDC | 12 VDC | 24 VDC | 24 VDC | 24 VDC |
| Slow Blow Fuse Type 3AG | 8A | 6A | 12A | 7A | 20A | 10A |
| Breaker Amps Max | 8A | 6A | 12A | 7A | 20A | 10A |

Solenoid Boots

Woodward solenoid boots are constructed of either epichlorohydrin (black boot) or silicone rubber (gray boot). Epichlorohydrin offers excellent resistance to oxygen, weather, fuels and oils. It is ideal for many automotive and off-road engine compartment applications. Silicone rubber is also resistant to most engine compartment chemicals with the advantage of retaining excellent flexibility at low temperatures and the ability to work well at high temperatures.

The boot type is either constant volume or bellows. Constant volume (CV) boots are designed so that the space inside the boot remains the same regardless of plunger position. With no change in volume there is no pressure buildup, which can reduce effective plunger force. A major benefit of the CV boot is that the boot can be totally sealed.

The bellows boot is necessary in longer stroke applications where the volume change is too great to be handled by a CV boot. The bellows boot typically has a small bleed hole in it so that air is not trapped on one side of the boot or the other, allowing the pressure to equalize. Therefore, the bellows boot is not a totally sealed design.

Solenoid Selection Guide

A guide to help you in the selection of Woodward's wide range of single and dual coil solenoids



Woodward's innovative designs and advanced engineering technology provide distinct performance advantages:

- Dual coil design provides both a high and low resistance coil for continuous operation in the widest ambient temperature range
- Dual coil solenoids pack more power in a smaller space than single coil solenoids
- Coils are potted on select models, sealing the entire unit for long, reliable service under extreme dirt and moisture conditions
- Plated steel housings and mounting brackets are corrosion resistant
- High temperature magnet wire insulation
- Hard chrome plated plunger for smooth, reliable, wear-resistant operation
- Brass plunger bore sleeve
- 100% inspected and factory tested

The true tests of solenoid excellence:

| | |
|-----------------------|--|
| Vibration test: | 15 to 2000 Hz @ 15 G's, 3 planes |
| Thermal cycling test: | -40°F to +250°F (-40°C to +121°C), 2 hours at each temperature with one hour transition, 25 cycles |
| Heat soak test: | 3 hours @ 250°F (121°C) at 120% rated voltage |
| Shock test: | 200 G's peak @ 21 Hz for 300 hours |

Solenoid Selection Guide

Solenoid Overview Chart:

| Dual Coil Model No.* | Direction | | Pull or Push Force | Hold Force | Stroke | Page No. |
|-------------------------|-----------|------|--------------------|----------------|-----------------|----------|
| | Pull | Push | | | | |
| 1502 | √ | | 10 lbs (44 N) | 24 lbs (107 N) | 1" (25.4 mm) | 12 |
| 1502ES | √ | | 10 lbs (44 N) | 28 lbs (125 N) | 1" (25.4 mm) | 12 |
| 1504 | √ | | 12 lbs (53 N) | 19 lbs (85 N) | 1" (25.4 mm) | 12 |
| 1751 | √ | | 24 lbs (107 N) | 38 lbs (169 N) | 1" (25.4 mm) | 14 |
| 1751ES | √ | | 25 lbs (111 N) | 41 lbs (182 N) | 1" (25.4 mm) | 14 |
| 1753 | √ | | 19 lbs (85 N) | 42 lbs (187 N) | 1" (25.4 mm) | 14 |
| 1753ES | √ | | 20 lbs (89 N) | 43 lbs (191 N) | 1" (25.4 mm) | 14 |
| 1756ES | | √ | 26 lbs (116 N) | 35 lbs (156 N) | 1" (25.4 mm) | 16 |
| 1765ESDB | | √ | 30 lbs (133 N) | 53 lbs (236 N) | 1" (25.4 mm) | 16 |
| 1757ES | | √ | 20 lbs (89 N) | 37 lbs (165 N) | 1" (25.4 mm) | 16 |
| 1757ESDB | | √ | 16 lbs (71 N) | 57 lbs (254 N) | 1" (25.4 mm) | 16 |
| 2001 | √ | | 21 lbs (93 N) | 49 lbs (218 N) | 1" (25.4 mm) | 18 |
| 2001ES | √ | | 22 lbs (98 N) | 43 lbs (191 N) | 1" (25.4 mm) | 18 |
| 2003 | √ | | 26 lbs (116 N) | 51 lbs (227 N) | 1" (25.4 mm) | 18 |
| 2003ES | √ | | 29 lbs (129 N) | 41 lbs (182 N) | 1" (25.4 mm) | 18 |
| 2370 | √ | | 37 lbs (165 N) | 88 lbs (391 N) | 1.5" (38.1 mm) | 20 |
| 2370ES | √ | | 39 lbs (173 N) | 92 lbs (409 N) | 1.5" (38.1 mm) | 20 |
| Cable Solenoid | √ | | 29 lbs (129 N) | 41 lbs (182 N) | 0.96" (24.5 mm) | 22 |

| Single Coil Model No.* | Direction | | Pull or Push Force | Hold Force | Stroke | Page No. |
|----------------------------|-----------|--------|---|--|------------------------------------|----------|
| | Pull | Push | | | | |
| 1000S 12 VDC | √ | | Against return spring with no side load on plunger pin | Against return spring with no side load on plunger pin | 0.17" (4.3 mm) | 24 |
| 1503S 12 VDC | √ | | Must pull in against return spring at 9 VDC and 100°F (38°C) or 2.25 lbs min. (10 N) or 8 lbs (35.6 N) at rated voltage | Must hold return spring at 9 VDC and 100°F (38°C) or 8 lbs (35.6 N) at rated voltage | 0.5" (12.7 mm) | 26 |
| 2370SP 12 VDC 24 VDC | | √ √ | 12 lbs (53.4 N) 16 lbs (71.2 N) | — | 0.85" (21.6 mm) 0.85" (21.6 mm) | 28 28 |
| 2370S 24 VDC | √ | | 16 lbs (71.2 N) | | 0.85" (21.6 mm) | 28 |

*All 12 VDC/24 VDC except where noted

Dual Coil Solenoids



Features:

- Dual coil design for higher pull force in a smaller package than similar size single coil solenoid
- Customer-specified option to switch from high current “pull” operation to low current “hold” operation with internal mechanical switch or external electronic switch
- Hold coil provides continuous duty operation
- Hard chrome plated plunger and brass liner for smooth, reliable, wear-resistant operation, tested on one million cycles
- Corrosion resistant plated steel housing and mounting base/flange
- Choice of flange, threaded, or base mountings
- Electrical connections available with choice of screw or spade terminals, or wire/connectors
- Two different boot types available; bellows boot is tapered to eliminate expansion in tight spots; constant volume boot has no breather hole and so provides contaminant protection of the plunger and bore

1500 Series

Models 1502, 1502ES & 1504 dual coil solenoids

Pull Force Range: 10-12 lbs (44-53 N)

Hold Force Range: 19-28 lbs (85-125 N)



| Model | Rated Voltage | Pull Rating* | Hold Rating* |
|--------|---------------|---------------|----------------|
| 1502 | 12/24 VDC | 10 lbs (44 N) | 24 lbs (107 N) |
| 1502ES | 12/24 VDC | 10 lbs (44 N) | 28 lbs (125 N) |
| 1504 | 12/24 VDC | 12 lbs (53 N) | 19 lbs (85 N) |

*At rated voltage, 68°F (20°C), and 1" (25.4 mm) stroke

Return Spring

| Model | Force @ 1" |
|-----------|-------------|
| S1 Light | 2.0-6.7 lbs |
| S2 Medium | 4.0-8.4 lbs |

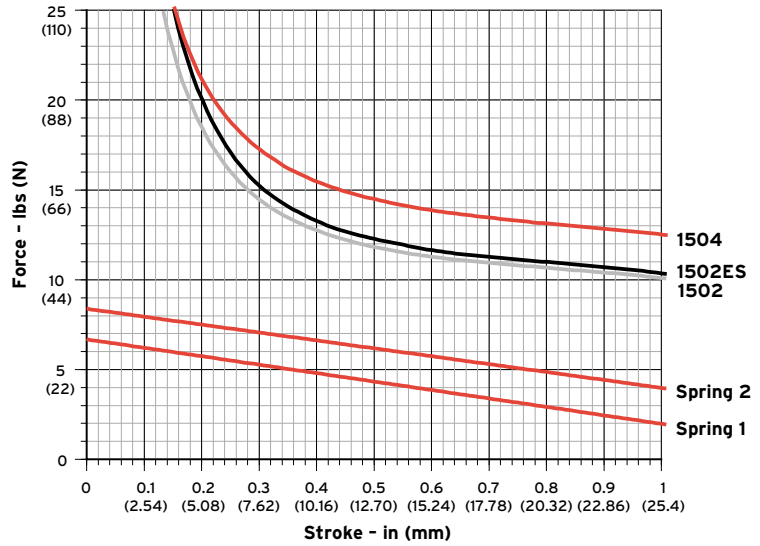

Order Information: Complete the following model descriptions to build your Order No.

() - () () () () () ()

| Model No. | Volts | Mounting Style | Plunger Type | Grounding (No. of Terminals) | Termination Type | Boot Type | Return Spring (Force @ 1") |
|---|---------------------|--------------------|---------------------------------|---|--------------------------|---|--------------------------------------|
| 1502 | 12 12 VDC | A Flange | 2 Ext. Thread ¼-28 | G Grounded (1 Terminal) | 1 Screw | B1 Constant Volume Epichlorohydrin | S1 Light (2.0-6.7 lbs) |
| 1502ES <small>Note: 1502ES offers Base Mounting, Ungrounded Terminals and Screw Type Termination only</small> | 24 24 VDC | B Thread | 3 Ext. Thread M-6 | U Ungrounded 1502 and 1504: (2 Terminals) 1502ES: (3 Terminals or Wire Leads) | 2 Spade | B2 Bellows Silicone Rubber | S2 Medium (4.0-8.4 lbs) |
| 1504 | | C Base | 6 Int. Thread ¼-28 | | L 3 Wire Leads | B4 Bellows Silicone Rubber | |
| | | D Flange | 7 Int. Thread M-6 | | | B5 Constant Volume Silicone Rubber | |

When you order: Add A to your order number for the Aux Terminal option available on internally switched models. Certain combinations may not be standard models. Please contact factory to determine whether a custom-built model is required for your application.

Mounting Styles:

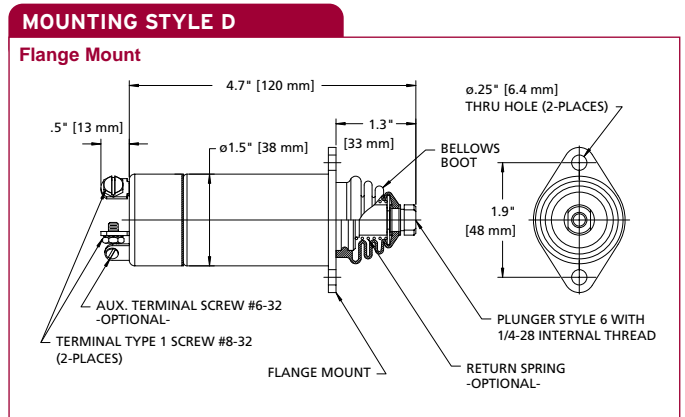
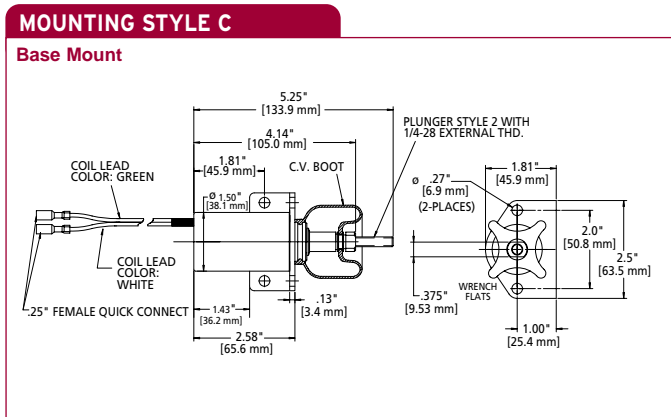
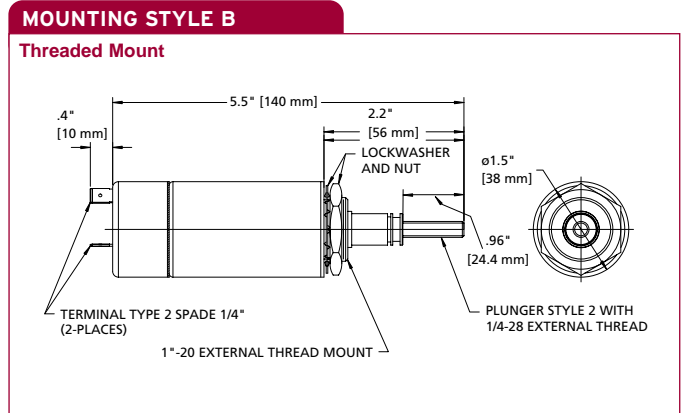
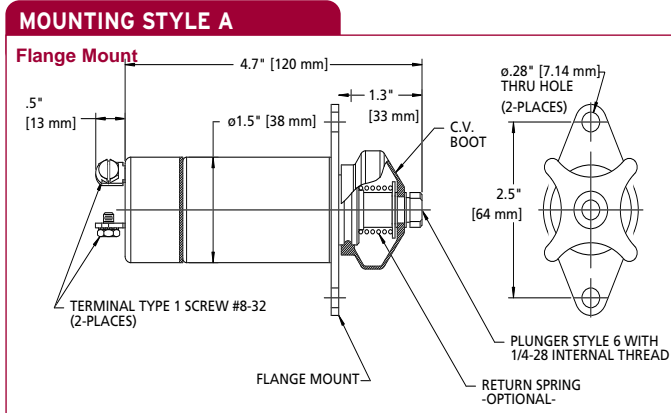

Specifications:

| | |
|-------------------|--------------------------------------|
| Temperature Range | -40°F to +250°F (-40°C to +121°C) |
| Weight | 1.0 lbs (0.5 kg) |

| Model | Rated Voltage | Rated Stroke | Pull Current | Hold Current | Pull Rating* | Hold Rating* | Coil Winding |
|--------|---------------|--------------|--------------|--------------|---------------|----------------|--------------|
| 1502 | 12 VDC | 1" (25.4 mm) | 30 A | 0.7 A | 10 lbs (44 N) | 24 lbs (107 N) | Parallel |
| 1502 | 24 VDC | 1" (25.4 mm) | 16 A | 0.24 A | 10 lbs (44 N) | 24 lbs (107 N) | Parallel |
| 1502ES | 12 VDC | 1" (25.4 mm) | 30 A | 0.7 A | 10 lbs (44 N) | 28 lbs (125 N) | Parallel |
| 1502ES | 24 VDC | 1" (25.4 mm) | 16 A | 0.24 A | 10 lbs (44 N) | 28 lbs (125 N) | Parallel |
| 1504 | 12 VDC | 1" (25.4 mm) | 41 A | 0.76 A | 12 lbs (53 N) | 19 lbs (85 N) | Parallel |
| 1504 | 24 VDC | 1" (25.4 mm) | 22 A | 0.37 A | 12 lbs (53 N) | 19 lbs (85 N) | Parallel |

*At rated voltage, 68°F (20°C), and 1" (25.4 mm) stroke

1750 Series

Models 1751, 1751ES, 1753 & 1753ES
dual coil solenoids

Pull Force Range: 19-25 lbs (85-111 N)

Hold Force Range: 38-43 lbs (169-191 N)



| Model | Rated Voltage | Pull Rating* | Hold Rating* |
|--------|---------------|----------------|----------------|
| 1751 | 12/24 VDC | 24 lbs (107 N) | 38 lbs (169 N) |
| 1751ES | 12/24 VDC | 25 lbs (111 N) | 41 lbs (182 N) |
| 1753 | 12/24 VDC | 19 lbs (85 N) | 42 lbs (187 N) |
| 1753ES | 12/24 VDC | 20 lbs (89 N) | 43 lbs (191 N) |

*At rated voltage, 68°F (20°C), and 1" (25.4 mm) stroke

Return Spring

| Model | Force @ 1" |
|-----------|------------|
| S1 Light | 4-8 lbs |
| S5 Medium | 7-11 lbs |

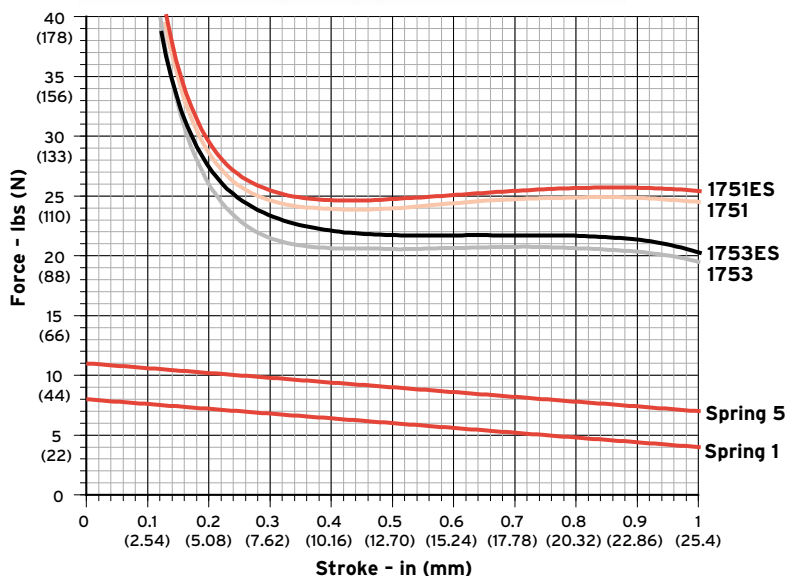

Order Information: Complete the following model descriptions to build your Order No.

| () | () | () | () | () | () | () | () |
|------------------|---------------------|-----------------------|---------------------------------|--|--|---|--|
| Model No. | Volts | Mounting Style | Plunger Type | Grounding (No. of Terminals) | Termination Type | Boot Type | Return Spring (Force @ 1") |
| 1751 | 12 12 VDC | A Flange | 2 Ext. Thread ¼-28 | U Ungrounded 1751 and 1751ES: (3 Terminals or Wire Leads) 1751, 1753 and 1753ES: (2 Terminals) | 1 Screw (1751 and 1753 only) | B1 Constant Volume Silicone Rubber | S1 Light (4-8 lbs) |
| 1751ES | 24 24 VDC | E Base | 3 Ext. Thread M-6 | | 2 Spade (1751 and 1753 only) | B2 Bellows Silicone Rubber | S5 Medium (7-11 lbs) Available on 1751 and 1751ES only |
| 1753 | | | 6 Int. Thread ¼-28 | | L 3 Wire Leads | B4 Bellows Silicone Rubber | |
| 1753ES | | | 7 Int. Thread M-6 | | C Connector attached to 3 Wire Leads | | |

Note: Contact factory for type and availability

When you order: Add A to your order number for the Aux Terminal option available on internally switched models. Certain combinations may not be standard models. Please contact factory to determine whether a custom-built model is required for your application.

Mounting Styles:

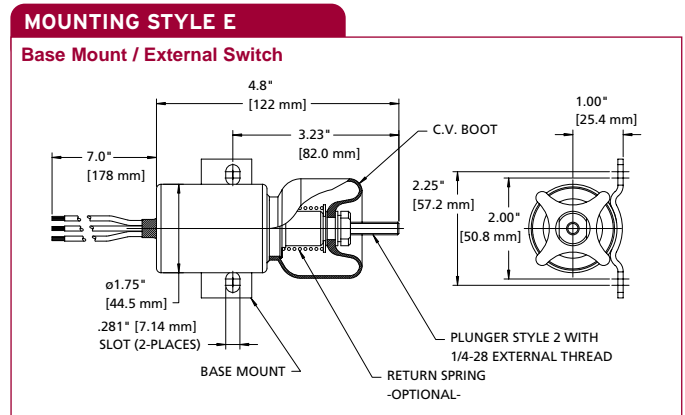
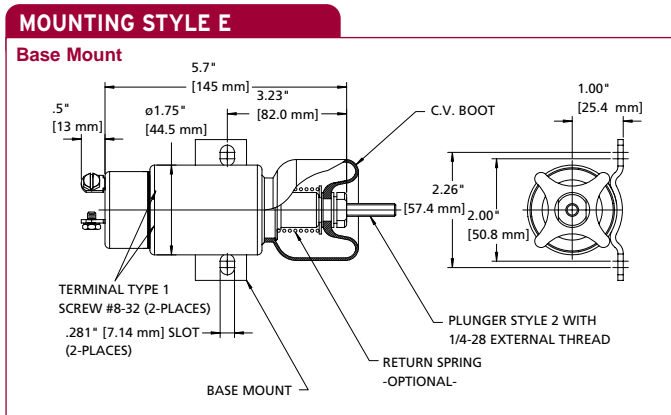
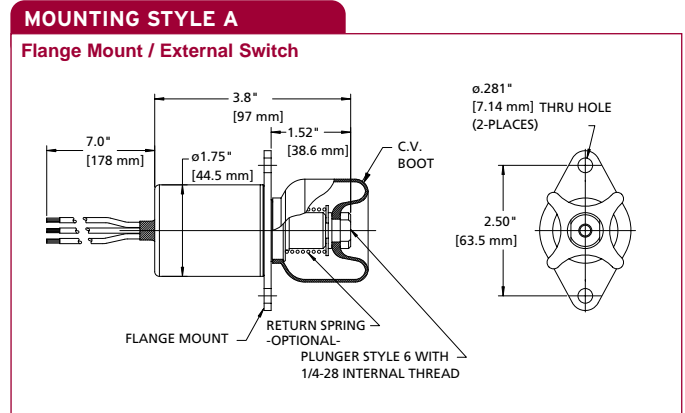
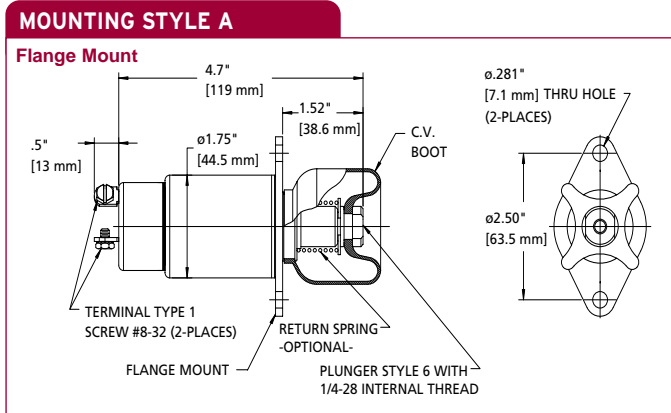

Specifications:

| | |
|-------------------|--------------------------------------|
| Temperature Range | -40°F to +250°F (-40°C to +121°C) |
| Weight | 1.5 lbs (0.7 kg) |

| Model | Rated Voltage | Rated Stroke | Pull Current | Hold Current | Pull Rating* | Hold Rating* | Coil Winding |
|--------|---------------|--------------|--------------|--------------|----------------|----------------|--------------|
| 1751 | 12 VDC | 1" (25.4 mm) | 46 A | 1.1 A | 24 lbs (107 N) | 38 lbs (169 N) | Parallel |
| 1751 | 24 VDC | 1" (25.4 mm) | 25 A | 0.5 A | 24 lbs (107 N) | 38 lbs (169 N) | Parallel |
| 1751ES | 12 VDC | 1" (25.4 mm) | 46 A | 1.1 A | 25 lbs (111 N) | 41 lbs (182 N) | Parallel |
| 1751ES | 24 VDC | 1" (25.4 mm) | 25 A | 0.5 A | 25 lbs (111 N) | 41 lbs (182 N) | Parallel |
| 1753 | 12 VDC | 1" (25.4 mm) | 33 A | 0.8 A | 19 lbs (85 N) | 42 lbs (187 N) | Parallel |
| 1753 | 24 VDC | 1" (25.4 mm) | 18 A | 0.4 A | 19 lbs (85 N) | 42 lbs (187 N) | Parallel |
| 1753ES | 12 VDC | 1" (25.4 mm) | 33 A | 0.8 A | 20 lbs (89 N) | 43 lbs (191 N) | Parallel |
| 1753ES | 24 VDC | 1" (25.4 mm) | 18 A | 0.4 A | 20 lbs (89 N) | 43 lbs (191 N) | Parallel |

*At rated voltage, 68°F (20°C), and 1" (25.4 mm) stroke

Specifications are for reference only.

1750 Push Series

Models 1756ES, 1756ESDB, 1757ES & 1757ESDB dual coil solenoids.

Externally switched push models available with double boot

Push Force Range: 16-26 lbs (71-116 N)

Hold Force Range: 35-56 lbs (156-249 N)



| Model | Rated Voltage | Push Rating* | Hold Rating* |
|-----------|---------------|----------------|----------------|
| 1756ES | 12/24 VDC | 26 lbs (116 N) | 35 lbs (156 N) |
| 1756ESDB | 12/24 VDC | 20 lbs (89 N) | 53 lbs (236 N) |
| 1757ES | 12/24 VDC | 20 lbs (89 N) | 37 lbs (165 N) |
| 1757 ESDB | 12/24 VDC | 16 lbs (71 N) | 56 lbs (249 N) |

*At rated voltage, 68°F (20°C), and 1" (25.4 mm) stroke

Return Spring

| Model | Force @ 1" |
|-----------|------------|
| S1 Light | 4-8 lbs |
| S5 Medium | 7-11 lbs |

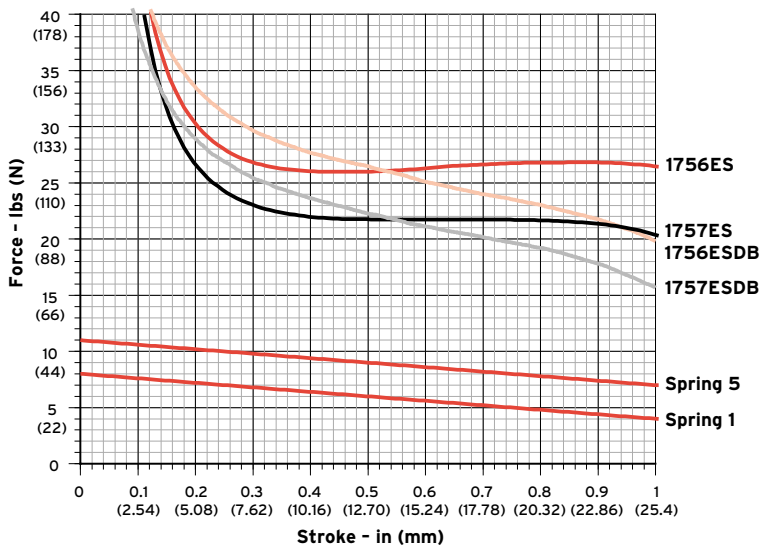

Order Information: Complete the following model descriptions to build your Order No.

| () | () | () | () | () | () | () | () |
|----------------------|---------------------|--------------------|-----------------------------------|--|---|---|--|
| Model No. | Volts | Mounting Style | Plunger Type | Grounding (No. of Terminals) | Termination Type | Boot Type | Return Spring (Force @ 1") |
| 1756ES | 12 12 VDC | A Flange | 2 Ext. Thread 1/4-28 | U Ungrounded (3 Terminals or Wire Leads) | L 3 Wire Leads | B1 Constant Volume Silicone Rubber Not available on ESDB models | S1 Light (4-8 lbs) |
| 1756 ESDB | 24 24 VDC | E Base | 3 Ext. Thread M-6 | | C Connector attached to 3 Wire Leads Note: Contact factory for type and availability | B2 Bellows Silicone Rubber | S5 Medium (7-11 lbs) Available on 1756ES and 1756ESDB only |
| 1757ES | | | | | | B4 Bellows Silicone Rubber | |
| 1757 ESDB | | | | | | | |

When you order: Certain combinations may not be standard models. Please contact factory to determine whether a custom-built model is required for your application.

Mounting Styles:

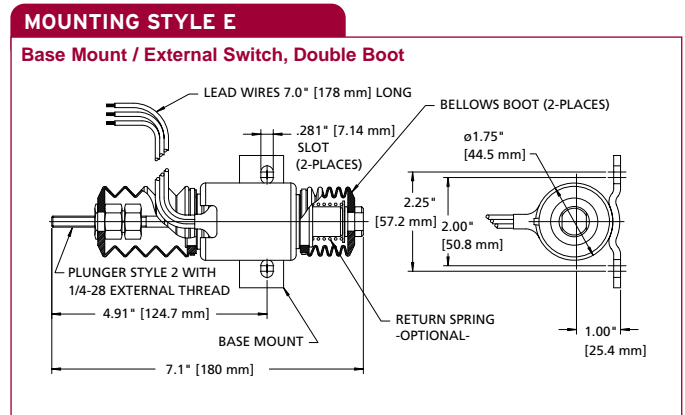
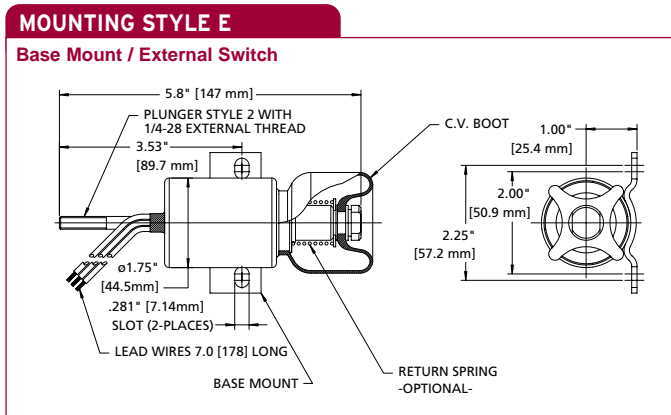
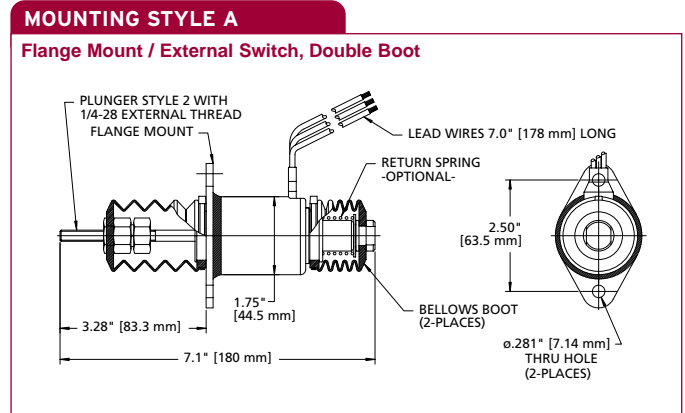
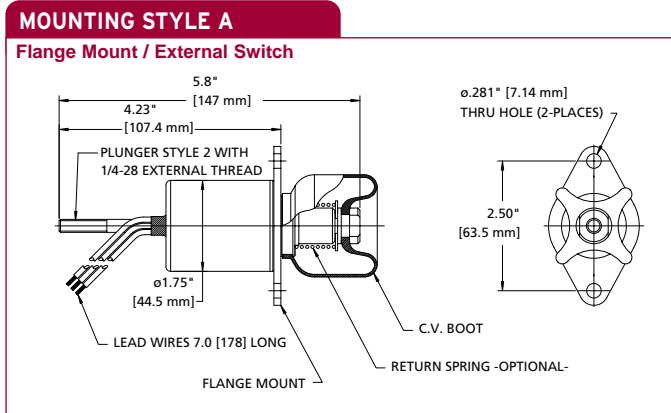

Specifications:

| | |
|-------------------|--------------------------------------|
| Temperature Range | -40°F to +250°F (-40°C to +121°C) |
| Weight | 1.5 lbs (0.7 kg) |

| Model | Rated Voltage | Rated Stroke | Push Current | Hold Current | Push Rating* | Hold Rating* | Coil Winding |
|----------|---------------|--------------|--------------|--------------|----------------|----------------|--------------|
| 1756ES | 12 VDC | 1" (25.4 mm) | 46 A | 1.1 A | 26 lbs (116 N) | 35 lbs (156 N) | Parallel |
| 1756ES | 24 VDC | 1" (25.4 mm) | 25 A | 0.5 A | 26 lbs (116 N) | 35 lbs (156 N) | Parallel |
| 1756ESDB | 12 VDC | 1" (25.4 mm) | 46 A | 1.1 A | 20 lbs (89 N) | 53 lbs (236 N) | Parallel |
| 1756ESDB | 24 VDC | 1" (25.4 mm) | 25 A | 0.5 A | 20 lbs (89 N) | 53 lbs (236 N) | Parallel |
| 1757ES | 12 VDC | 1" (25.4 mm) | 33 A | 0.8 A | 20 lbs (89 N) | 37 lbs (165 N) | Parallel |
| 1757ES | 24 VDC | 1" (25.4 mm) | 18 A | 0.4 A | 20 lbs (89 N) | 37 lbs (165 N) | Parallel |
| 1757ESDB | 12 VDC | 1" (25.4 mm) | 33 A | 0.8 A | 16 lbs (71 N) | 56 lbs (249 N) | Parallel |
| 1757ESDB | 24 VDC | 1" (25.4 mm) | 18 A | 0.4 A | 16 lbs (71 N) | 56 lbs (249 N) | Parallel |

*At rated voltage, 68°F (20°C), and 1" (25.4 mm) stroke

Specifications are for reference only.

2000 Series

Models 2001, 2001ES, 2003, 2003ES
dual coil solenoids

Pull Force Range: 21-29 lbs (93-129 N)
Hold Force Range: 41-51 lbs (182-227 N)



| Model | Rated Voltage | Pull Rating* | Hold Rating* |
|--------|---------------|----------------|----------------|
| 2001 | 12/24 VDC | 21 lbs (93N) | 49 lbs (218 N) |
| 2001ES | 12/24 VDC | 22 lbs (98 N) | 43 lbs (191 N) |
| 2003 | 12/24 VDC | 26 lbs (116 N) | 51 lbs (227 N) |
| 2003ES | 12/24 VDC | 29 lbs (129 N) | 41 lbs (182 N) |

*At rated voltage, 68°F (20°C), and 1" (25.4 mm) stroke

Return Spring

| Model | Force @ 1" |
|-----------|------------|
| S1 Light | 4-8 lbs |
| S2 Medium | 8-14 lbs |
| S4 Heavy | 14-17 lbs |

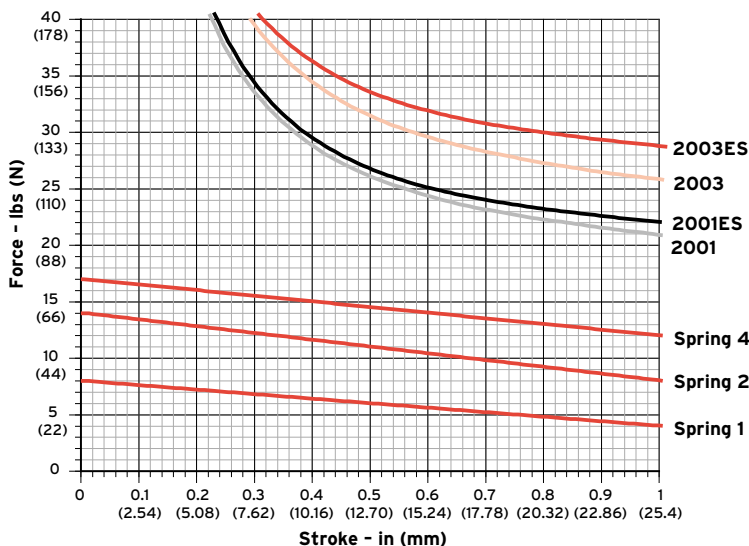

Order Information: Complete the following model descriptions to build your Order No.

| () | () | () | () | () | () | () | () |
|------------------|---------------------|-----------------------|-----------------------------------|--|---|--|--|
| Model No. | Volts | Mounting Style | Plunger Type | Grounding (No. of Terminals) | Termination Type | Boot Type | Return Spring (Force @ 1") |
| 2001 | 12 12 VDC | E Base | 2 Ext. Thread 1/4-28 | G Grounded (1 Terminal) | 1 Screw | B1 Constant Volume Silicone Rubber | S1 Light (4-8 lbs) |
| 2003 | 24 24 VDC | S* Flange | 3 Ext. Thread M-6 | U Ungrounded 2001 and 2003: (2 Terminals) 2001ES and 2003ES: (3 Terminals or Wire Leads) | L 3 Wire Leads Note: 2001ES and 2003ES only | B2 Bellows Silicone Rubber | S2 Medium (8-14 lbs) |
| 2001ES | | | 6 Int. Thread 1/4-28 | | C Connector attached to 3 Wire Leads Note: Contact factory for type and availability. 2001ES and 2003ES only | B3 Constant Volume Silicone Rubber Red | S4 Heavy (12-17 lbs) Available on 2003 and 2003ES only |
| 2003ES | | | 7 Int. Thread M-6 | | | B4 Bellows Silicone Rubber | |
| | | | | | | B5 Constant Volume Silicone Rubber | |

*Flange mounting not available for ES models.

When you order: Add A to your order number for the Aux Terminal option or C for the Conduit Cover available on internally switched models. Certain combinations may not be standard models. Please contact factory to determine whether a custom-built model is required for your application.

Mounting Styles:

MOUNTING STYLE E

Base Mount

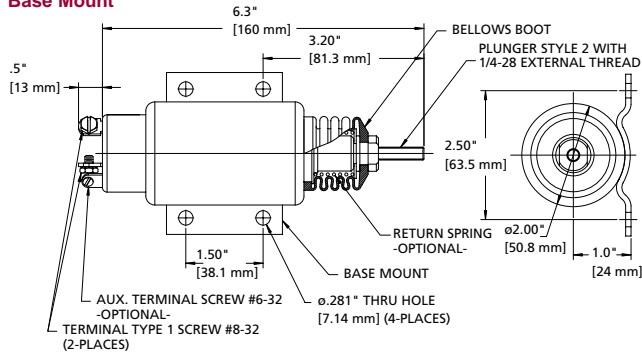

MOUNTING STYLE E

Base Mount / External Switch

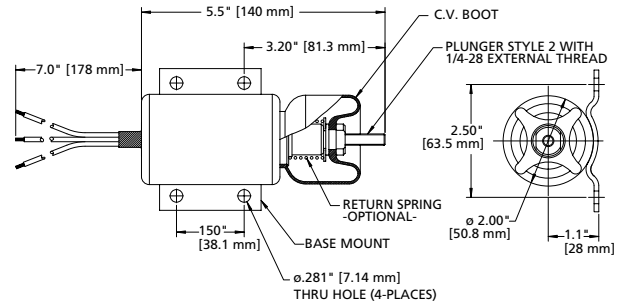

MOUNTING STYLE S

Flange Mount

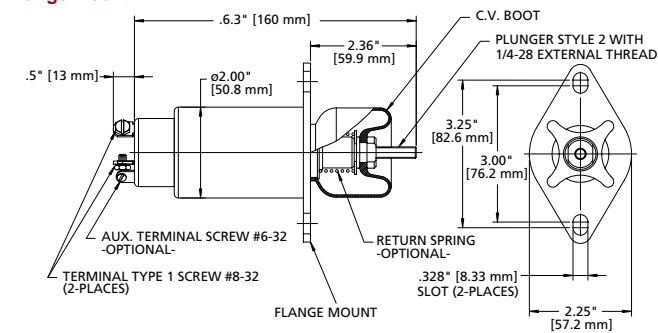

Specifications:

Temperature Range

-40°F to +250°F
(-40°C to +121°C)

Weight

2.5 lbs (1.2 kg)

| Model | Rated Voltage | Rated Stroke | Pull Current | Hold Current | Pull Rating* | Hold Rating* | Coil Winding |
|--------|---------------|--------------|--------------|--------------|----------------|----------------|--------------|
| 2001 | 12 VDC | 1" (25.4 mm) | 44 A | 0.6 A | 21 lbs (93 N) | 49 lbs (218 N) | Series |
| 2001 | 24 VDC | 1" (25.4 mm) | 23 A | 0.3 A | 21 lbs (93 N) | 49 lbs (218 N) | Series |
| 2001ES | 12 VDC | 1" (25.4 mm) | 44 A | 0.6 A | 22 lbs (98 N) | 43 lbs (191 N) | Parallel |
| 2001ES | 24 VDC | 1" (25.4 mm) | 23 A | 0.3 A | 22 lbs (98 N) | 43 lbs (191 N) | Parallel |
| 2003 | 12 VDC | 1" (25.4 mm) | 60 A | 0.8 A | 26 lbs (116 N) | 51 lbs (227 N) | Series |
| 2003 | 24 VDC | 1" (25.4 mm) | 37 A | 0.4 A | 26 lbs (116 N) | 51 lbs (227 N) | Series |
| 2003ES | 12 VDC | 1" (25.4 mm) | 62 A | 0.9 A | 29 lbs (129 N) | 41 lbs (182 N) | Parallel |
| 2003ES | 24 VDC | 1" (25.4 mm) | 39 A | 0.5 A | 29 lbs (129 N) | 41 lbs (182 N) | Parallel |

*At rated voltage, 68°F (20°C), and 1" (25.4 mm) stroke

Specifications are for reference only.

2370 Series

Models 2370 and 2370ES dual coil solenoids

Pull Force Range: 37-39 lbs (165-173 N)

Hold Force Range: 88-92 lbs (391-409 N)



| Model | Rated Voltage | Pull Rating* | Hold Rating* |
|--------|---------------|----------------|----------------|
| 2370 | 12/24 VDC | 37 lbs (165N) | 38 lbs (391 N) |
| 2370ES | 12/24 VDC | 39 lbs (173 N) | 88 lbs (391 N) |

*At rated voltage, 68°F (20°C) and 1.5" (38.1 mm) stroke

Return Spring

| Model | Force @ 1" |
|----------|---------------|
| S1 Light | 17.6-26.0 lbs |

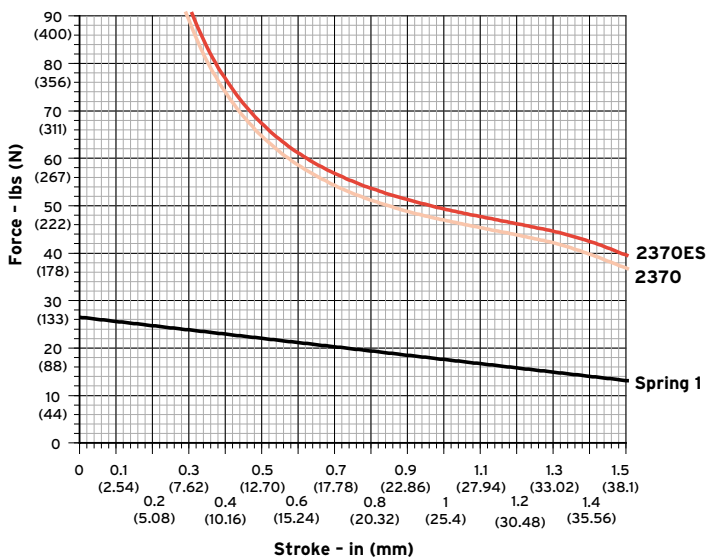

Order Information: Complete the following model descriptions to build your Order No.

| | | | | | | | |
|------------------|---------------------|-----------------------|---------------------------------------|---|---|--|---------------------------------------|
| () | - | () | () | () | () | () | () |
| Model No. | Volts | Mounting Style | Plunger Type | Grounding (No. of Terminals) | Termination Type | Boot Type | Return Spring (Force @ 1") |
| 2370 | 12 12 VDC | E Base | 2 Ext. Thread 3/16-24 | G Grounded (1 Terminal) | 1 #8 Screw | B2 Bellows Epichlorohydrin | S1 Light (17.6-26.0 lbs) |
| 2370ES | 24 24 VDC | | 3 Ext. Thread M-8 x 1.25 | U Ungrounded 2370: (2 Terminals) 2370ES: (3 Terminals or Wire Leads) | 3 #8 Stud | B5 Constant Volume Silicone Rubber | |
| | | | 6 Int. Thread 3/16-24 | | 6 #10 Stud | | |
| | | | 7 Int. Thread M-8 x 1.25 | | L 3 Wire Leads | | |
| | | | | | C Connector attached to 3 Wire Leads Note: Contact factory for type and availability | | |

When you order: Add A to your order number for the Aux Terminal option available on internally switched models. Certain combinations may not be standard models. Please contact factory to determine whether a custom-built model is required for your application.

Mounting Styles:

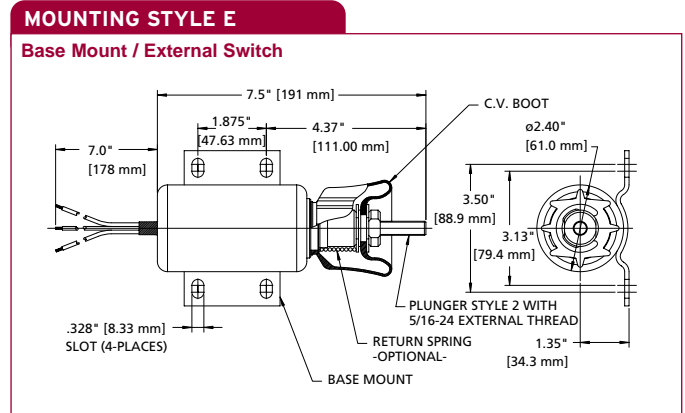
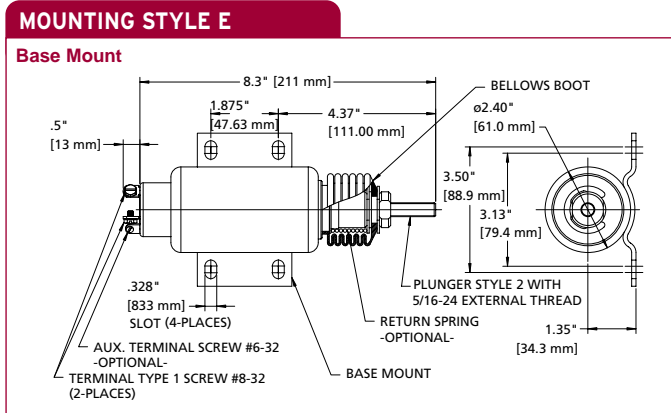

Specifications:

| | |
|-------------------|--------------------------------------|
| Temperature Range | -40°F to +250°F (-40°C to +121°C) |
| Weight | 5 lbs (2.3 kg) |

| Model | Rated Voltage | Rated Stroke | Pull Current | Hold Current | Pull Rating* | Hold Rating* | Coil Winding |
|--------|---------------|----------------|--------------|--------------|----------------|----------------|--------------|
| 2370 | 12 VDC | 1.5" (38.1 mm) | 58 A | 1.7 A | 37 lbs (165 N) | 88 lbs (391 N) | Series |
| 2370 | 24 VDC | 1.5" (38.1 mm) | 31 A | 0.6 A | 37 lbs (165 N) | 88 lbs (391 N) | Series |
| 2370ES | 12 VDC | 1.5" (38.1 mm) | 58 A | 1.7 A | 39 lbs (173 N) | 92 lbs (409 N) | Parallel |
| 2370ES | 24 VDC | 1.5" (38.1 mm) | 31 A | 0.6 A | 39 lbs (173 N) | 92 lbs (409 N) | Parallel |

*At rated voltage, 68°F (20°C) and 1.5" (38.1 mm) stroke

Cable Solenoid

Patented, remote cable link solenoid can be used for throttle advance or shutdown requirements. Ideal for applications with space restrictions, extremely hot environments or excessive vibration.



Features:

- Remote mount for installation away from constrained or hostile environments
- Assembled with Model 2003ES high-force solenoid
- 8-14 pound return spring standard for start/stop applications.
- Heavy-duty cable withstands temperature ranges of -63°F to +250°F (-53°C to +121°C)
- Spherical rod end with 0.237" (6 mm) diameter hole
- Corrosion resistant plated steel housing and mounting
- Coils are potted to seal entire solenoid for reliable service under extreme vibration, temperature, dirt, and moisture conditions
- Options include connectors, flexible conduit over leads, and Coil Commander™ solenoid protection modules
- Patented

Solenoid Model 2003ES Features:

- 12 or 24 VDC
- Base mount
- Ungrounded 3-wire leads
- Return spring 8 lbs (3.6 kg) at rated voltage, 68°F (20°C) and 1" (25.4 mm) stroke

Order Information:

| ORDER NO. | Voltage |
|------------|---------|
| SA-4744-12 | 12 VDC |
| SA-4744-24 | 24 VDC |

Cable Solenoid

DIMENSIONS

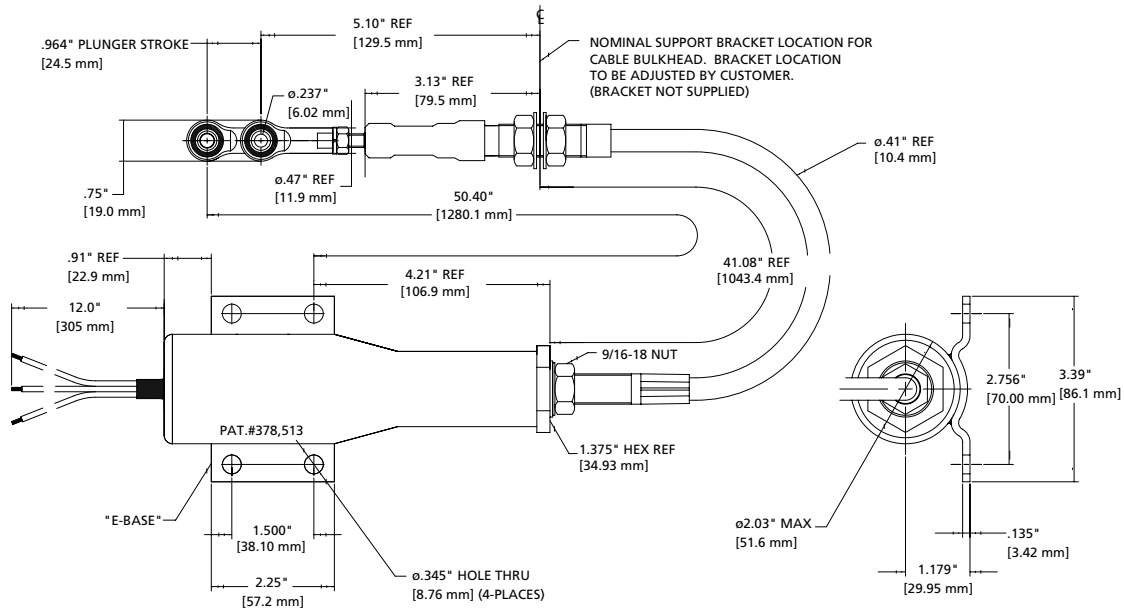

Specifications:

At rated voltage, 68°F (20°C)
and .964" (24.5 mm) stroke

| | | |
|--------------|--------------------|---------------|
| Voltage | <u>12 VDC</u> | <u>24 VDC</u> |
| Pull Current | 61.8 A | 39.0 A |
| Hold Current | 0.85 A | 0.46 A |
| Pull Force | 29 lbs (129 N) | |
| Hold Force | 41 lbs (182 N) | |
| Cable Length | 41.08" (1043.4 mm) | |
| Total Length | 50.4" (1280.1 mm) | |

Force vs. Stroke

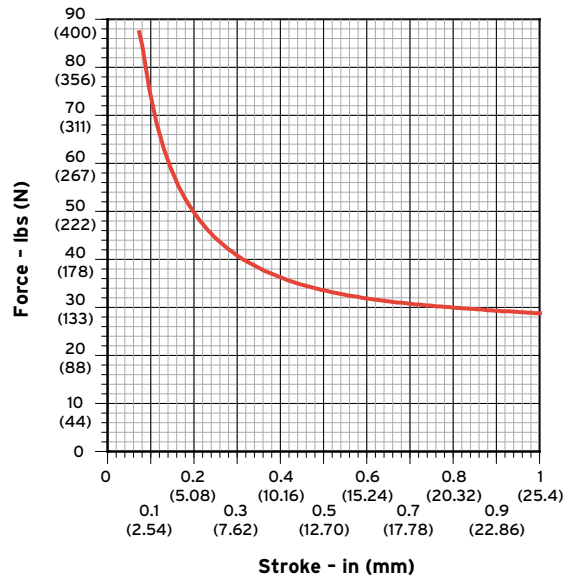

1000S Series Locking Solenoid

Heavy-duty locks designed for side-load resistance in hydraulic or mechanical applications. Plunger can withstand 1500 pounds of side load in the de-energized position.



Features:

- Single coil construction for simple electrical interface
- Hardened, stainless steel pin resists high shear load and increases fatigue resistance
- Nickel plated plunger ensures smooth, reliable operation, as well as corrosion and wear resistance
- Protective brass liner plunger bore provides longer operating life
- Rugged construction allows for operation under the most severe temperature and vibration conditions
- Easy installation—no brackets or linkages necessary

Order Information:

| ORDER NO. | Model |
|-----------|------------|
| SA-4971 | Continuous |
| SA-4972 | PWM |

1000S Series Locking Solenoid

DIMENSIONS

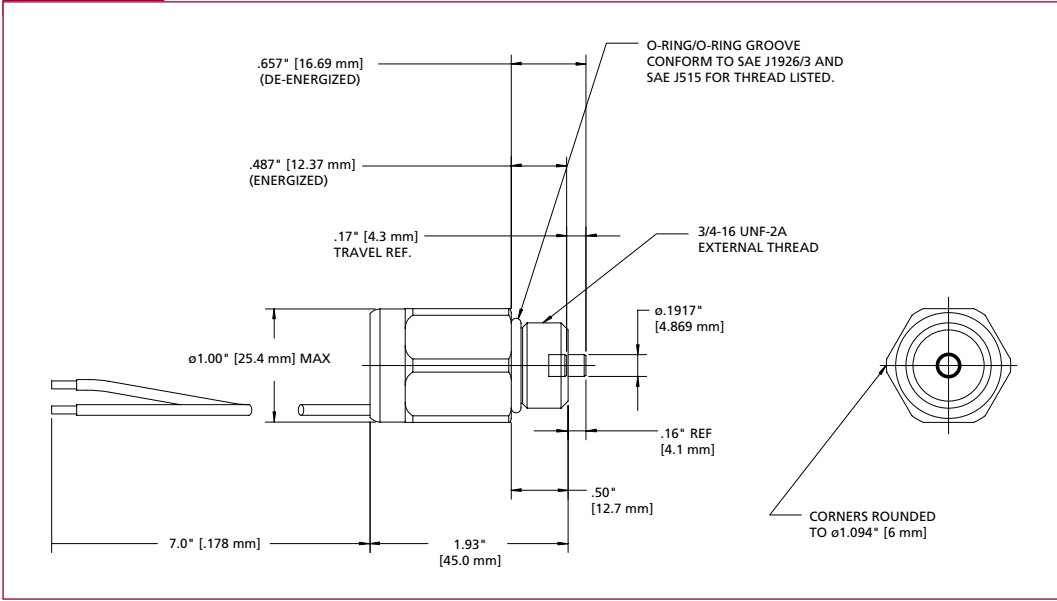

Specifications:

SA-4971

SA-4972

| | | |
|----------------------|---|--|
| Rated Voltage | 12 VDC | 12 VDC |
| Rated Temperature | 68 °F (20 °C) | 68 °F (20 °C) |
| Temperature Range | -40 °F to + 185 °F (-40 °C to +85 °C) | -40 °F to + 235 °F (-40 °C to +113 °C) |
| Rated Stroke | 0.17" (4.32 mm) | 0.17" (4.32 mm) |
| Pull Current | 100% duty @ 0.7 A | 2 A max for 0.2 sec |
| Hold Current | 100% duty @ 0.7 A | PWM 1.0 A average |
| Duty Cycle | 100% @ 15.5 VDC max and 185 °F (85 °C) | 15% @ 16 VDC |
| Pull Force | Solenoid must pull in plunger against return spring at 9.5 VDC and 320 °F (160 °C) coil temperature, with no side load on plunger pin | Solenoid must pull in plunger against return spring at 9.5 VDC and 235 °F (113 °C) within 200 msec, with no side load on plunger pin |
| Hold Force | Solenoid must hold in plunger against return spring at 9.5 VDC and 320 °F (160 °C) coil temperature | Solenoid must hold in plunger against return spring at 16 VDC, 15% duty cycle, 1000 Hz PWM signal, and 235 °F (113 °C) |
| Pull Coil Resistance | 17.8 ohms ± 10% | 5.55 ohms ± 5% |

Specifications are for reference only.

1503S Series

Typically designed for continuous duty, with single coil performing both the pull and hold function for the solenoid.



Features:

- Continuous duty operation
- Hard chrome plated plunger for smooth, reliable, wear-resistant operation
- Brass liner plunger bore for long life
- Corrosion resistant plated steel housing and mounting base/flange
- Potted coil construction
- Variety of options for mounting bases/flanges, plungers, terminations, boots, and springs
- 100% inspected and factory tested

Order Information:

| ORDER NO. | Model | Termination |
|-----------|-------|-------------|
| SA-4741 | 0151 | Leads |

SA-4741

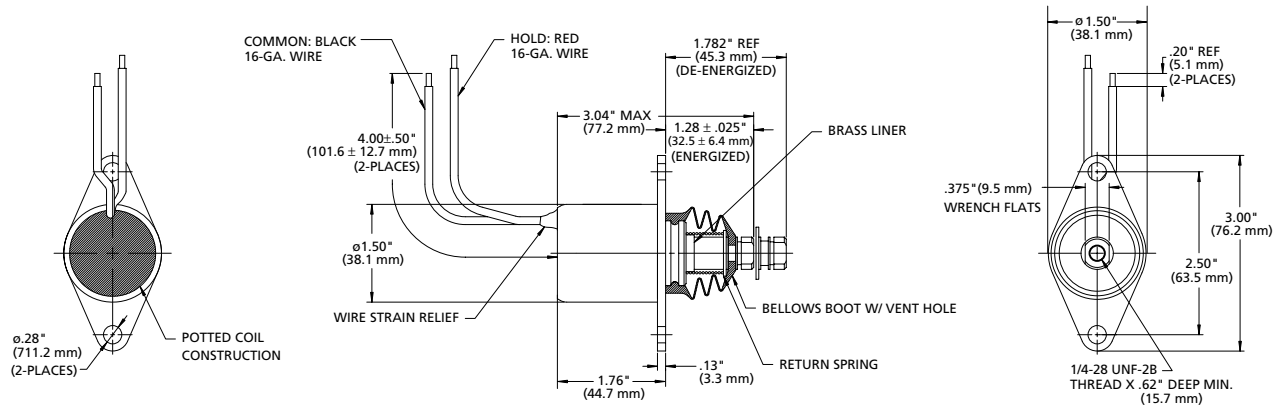

Specifications:

| | |
|-----------------------|---|
| Rated Voltage | 12 VDC |
| Rated Current | 4.7 A |
| Rated Temperature | 68°F (20°C) |
| Temperature Range | -20°F to +250°F (-29°C to +121°C) |
| Nominal Rated Stroke | 0.5" (12.7 mm) |
| Pull Force | Must pull in against return spring at 9 VDC and 100°F (38°C) or 2.25 lbs min. (10 N) at rated voltage |
| Hold Force | Must hold return spring at 9 VDC and 100°F (38°C) or 8 lbs (35.6 N) at rated voltage |
| Nominal Spring Return | |
| De-energized: | 1.16 ± 0.16 lbs (5.16 ± 0.71 N) |
| Energized: | 1.56 ± 0.25 lbs (6.94 ± 1.11 N) |
| Pull Coil Resistance | 2.53 ohms ± 10% |
| Duty Cycle | Intermittent, 25% duty cycle, 5 minutes maximum ON time |
| Vibration | 15 G's @ 50-500 Hz |
| Shock | 200 G's, 0-peak @ 21 Hz |

Timer Module Basics

- 5-Wire Coil Commander®
- 6-Wire Coil Commander®
- 7-Wire SSR Coil Commander®
- Pull Coil Timer Modules



Timer Modules

Dual coil solenoids are constructed of two wound coils. The pull coil operates at high currents in order to provide maximum pull or push force. The hold coil retains the plunger in place after it has completed its stroke. After energizing, the pull coil must be turned off as soon as possible to prevent burnout.

Timer modules protect Woodward solenoids from burnout caused by engine over cranking or the misadjustment of linkages. The protective modules energize and de-energize the solenoid pull coil within approximately 1½ seconds.

Woodward makes two types of solenoid protection systems: Coil Commander® modules and pull coil timer modules (PCTM).

Timer Module Basics

Coil Commander® Modules

Coil Commanders time out a solenoid's high amperage pull coil within approximately 1½ seconds. The in-line cylindrical tube design comes in 5-, 6-, and 7-wire SSR configurations:

| | |
|-------------------|---|
| 5-Wire Module | When used with a 3-wire externally switched solenoid, the combined unit functions similarly to an internally switched solenoid without modification to existing wiring harness. |
| 6-Wire Module | Provides a quick, easy fix to prevent burnout for externally switched installations that are connected to the "S" terminal on the starter. |
| 7-Wire SSR Module | When used with a 4-wire externally switched solenoid, the combined unit functions similarly to an internally switched solenoid and eliminates the need for a separate solenoid relay. |

Stand-alone units are lightweight and need no mounting brackets. Modules are also available with solenoid attached.

Maximum ON/OFF Duty Cycles for Coil Commander® Modules

At de-rated conditions: 125% of rated voltage and 250°F (121°C)

| | Continuous | Intermittent |
|--------|-----------------|-------------------------------|
| 12 VDC | 2 cycles/minute | 4 cycles/minute for 5 minutes |
| 24 VDC | 1 cycle/minute | 3 cycles/minute for 5 minutes |

PCTM Modules

These timers protect externally switched solenoids by limiting the pull coil ON time to ½ second. Use of the PCTM provides enhanced solenoid performance, as an externally switched unit performs like an internally switched solenoid but with greater durability and reliability.

Note: Coil Commanders and PCTM's will reduce the available pull coil voltage by approximately ½ to 1 volt.

5-Wire Coil Commander®

Provides the functionality of an internally switched solenoid when used with a 3-wire externally switched solenoid.



Features:

- Prevents solenoid burnout due to engine over cranking or misadjustment of linkage by limiting the pull coil ON time
- Potted and sealed solid-state electronics
- Separate mounting bracket not required
- Stand alone plug-in or factory assembled to solenoid
- Patented

Order Information:

Stand Alone Modules

| ORDER NO. | Rated Voltage | Max. Current at 68°F (20°C) | Terminations To System Harness | Terminations To Solenoid |
|-------------------|---------------|-----------------------------|--|---|
| SA-4624-12 | 12 VDC | 70 A | Leads | Packard Weather Pack Housing No. 12020829 |
| SA-4624-24 | 24 VDC | 40 A | Leads | Packard Weather Pack Housing No. 12020829 |
| SA-4626-12 | 12 VDC | 70 A | Packard Weather Pack Housing No. 12020827 | Packard Weather Pack Housing No. 12020829 |
| SA-4626-24 | 24 VDC | 40 A | Packard Weather Pack Housing No. 12020827 | Packard Weather Pack Housing No. 12020829 |
| SA-4630-12 | 12 VDC | 70 A | Packard Weather Pack Housing No. 12010973 | Yazaki Housing No. 7123-2137 |
| SA-4634-12 | 12 VDC | 90 A | Packard Weather Pack Housing No. 12010973 | Packard Weather Pack Housing No. 12020829 |
| SA-4634-24 | 24 VDC | 60 A | Packard Weather Pack Housing No. 12010973 | Packard Weather Pack Housing No. 12020829 |
| SA-4686-12 | 12 VDC | 70 A | Leads | Leads |
| SA-4686-24 | 24 VDC | 40 A | Leads | Leads |
| SA-4687-12 | 12 VDC | 90 A | Leads | Leads |
| SA-4687-24 | 24 VDC | 60 A | Leads | Leads |
| SA-4822-12 | 12 VDC | 90 A | Metri-Pack 280 Series Housing No. 15300002 | Packard Weather Pack Housing No. 12020829 |

Built-in Modules

Contact Woodward for factory assembled units

Minimum quantities required for non-standard configurations. Contact factory for details.

5-Wire Coil Commander®

TERMINATION CONNECTIONS

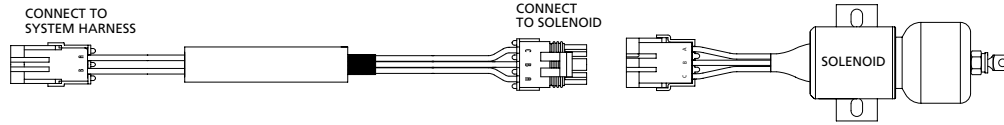

ELECTRIC SHUTOFF

Electric shutoff with dedicated relay for fuel solenoid

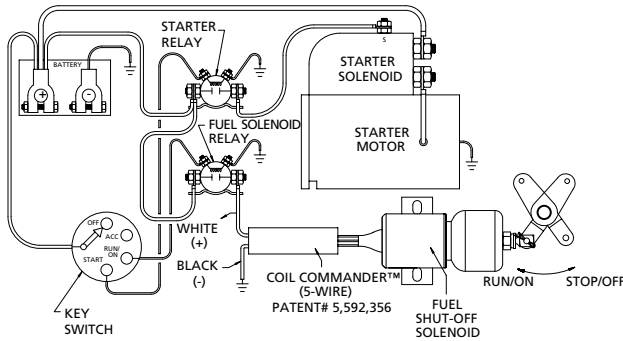

THROTTLE/CHOKE SOLENOID

Throttle/choke solenoid with dedicated relay for fuel solenoid

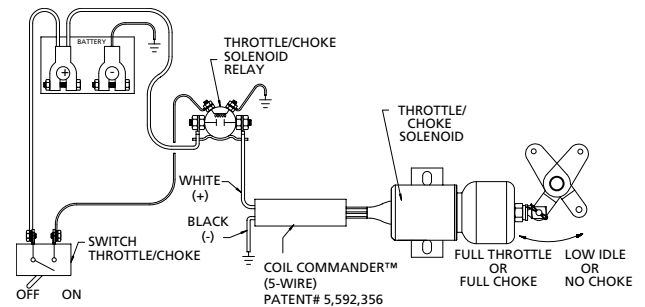

DIMENSIONS

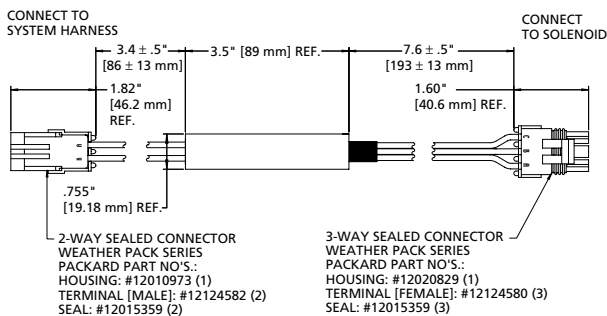

Note: Coil Commanders will reduce the available pull coil voltage by approximately ½ to 1 volt.

Specifications:

| | | |
|--|--------------------------------------|---------|
| Temperature | -40°F to +250°F (-40°C to +121°C) | |
| Vibration | 15 G's @ 15-2000 Hz | |
| Rated Voltage Minimum Input Voltage @ 68° F (20°C) Rated Jump Start Voltage (<5 min) | 12 Volt | 24 Volt |
| | 9 VDC | 18 VDC |
| | 24 VDC | 48 VDC |
| Reverse Polarity Protection | None | |
| Weight | Approx. 4 oz. (113 g) | |

Specifications are for reference only.

E.E.C. Directive Compliance: All parts supplied by Woodward are classified as components, and therefore are not "CE" marked. Please contact factory direct for details on specific product compliance with 89/336/EEC and 89/392/EEC directives.

6-Wire Coil Commander®

Plugs into existing externally switched solenoid installations without wiring modification when used with optional connectors. Works with installations connected to "S" terminal on starter.



Features:

- Prevents solenoid burnout due to engine over crank or misadjustment of linkage by limiting the pull coil ON time
- Potted and sealed solid-state electronics
- Separate mounting bracket not required
- Stand alone plug-in or factory assembled to solenoid
- Patented

Order Information:

Stand Alone Modules

| ORDER NO. | Rated Voltage | Max. Current at 68°F (20°C) | Terminations To System Harness | Terminations To Solenoid |
|-----------------|---------------|-----------------------------|--|---|
| SA-4751 | 9-36 VDC | 86 A | Packard Weather Pack Housing No. 12020827 | Packard Weather Pack Housing No. 12020829 |
| SA-4759 | 9-36 VDC | 86 A | Leads | Leads |
| SA-4945* | 9-36 VDC | 86 A | Yazaki Housing-Male No. 7122-2237-00 | Yazaki Housing-Female No. 7123-2137 |
| SA-5028 | 9-36 VDC | 86 A | Packard Metri-Pack 280 Housing No. 1530003 | Packard Metri-Pack 280 Housing No. 12040977 |
| SA-5160 | 9-36 VDC | 86 A | Yazaki Housing-Male No. 7122-2237-00 | Yazaki Housing-Female No. 7123-2137 |

*For use with Kubota 1503ES solenoids

Built-in Modules

Contact Woodward for factory assembled units

Minimum quantities required for non-standard configurations. Contact factory for details.

TERMINATION CONNECTIONS

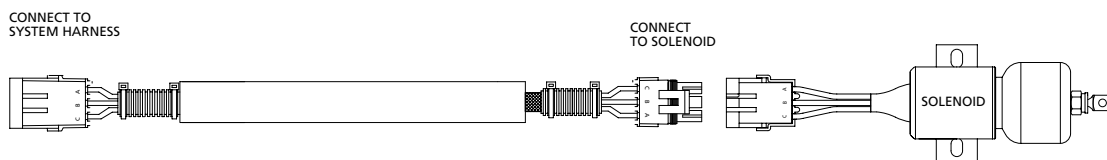

E.E.C. Directive Compliance: All parts supplied by Woodward are classified as components, and therefore are not "CE" marked. Please contact factory direct for details on specific product compliance with 89/336/EEC and 89/392/EEC directives.

6-Wire Coil Commander®

DIMENSIONS

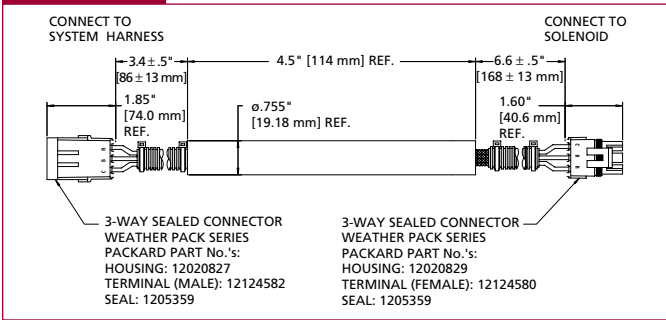

ELECTRIC SHUTOFF

Electric shutoff with dedicated relay for fuel solenoid

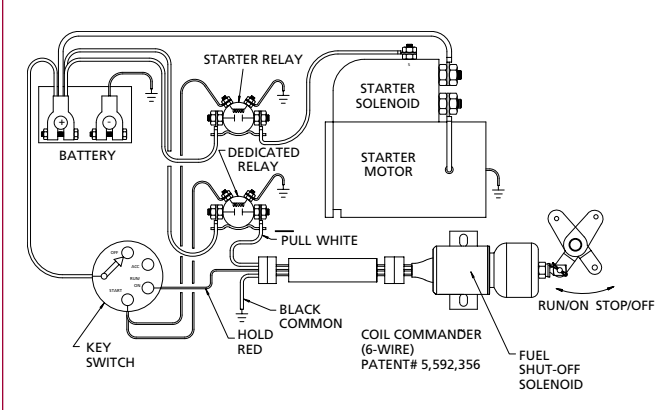

THROTTLE/CHOKE SOLENOID

Throttle/choke solenoid shown with Coil Commander wired to starter. This method requires approval from the starter motor manufacturer.

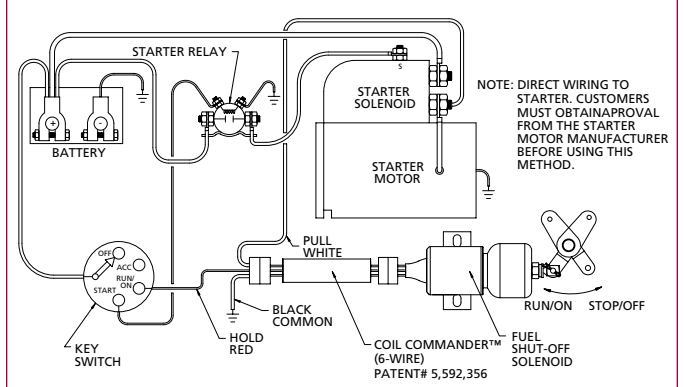

RECOMMENDED CONNECTION

Connection of solenoid to "S" terminal is acceptable with 6-wire Coil Commander.

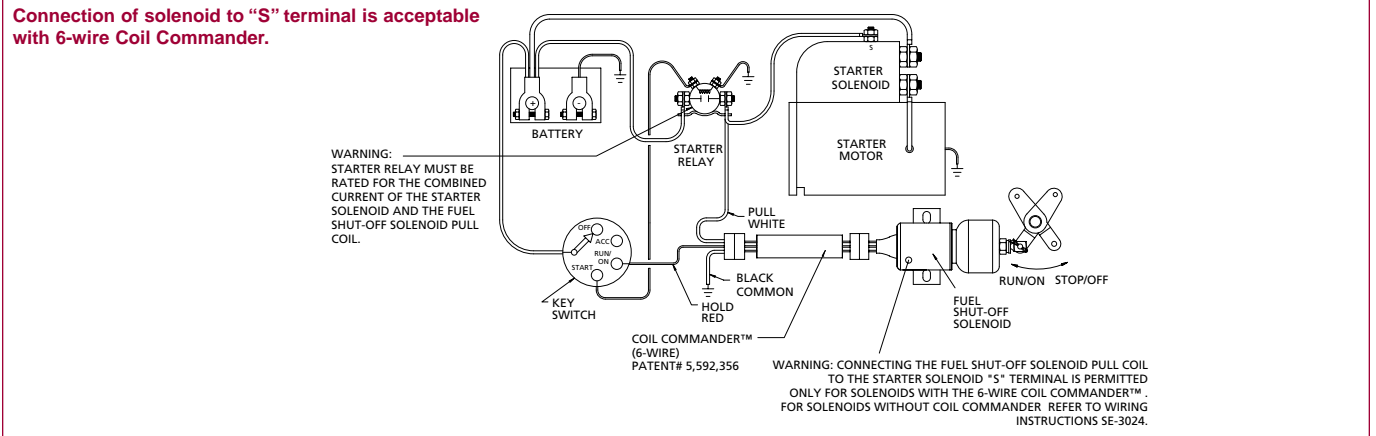

NON-RECOMMENDED CONNECTION

Connection of solenoid to "S" terminal is not recommended.

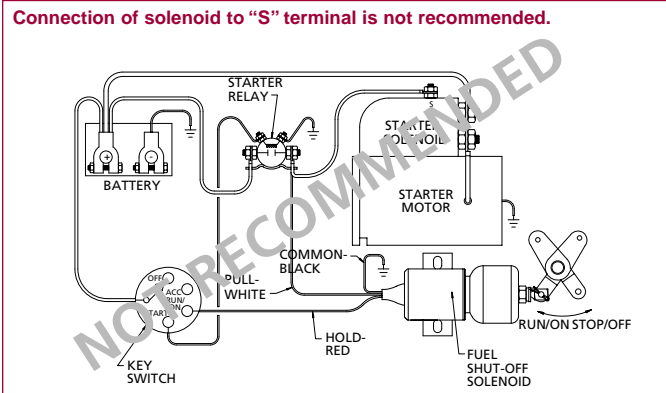

Specifications are for reference only.

Note: Coil Commanders will reduce the available pull coil voltage by approximately ½ to 1 volt.

Specifications:

| | | |
|-----------------------------|--|---------------|
| Temperature | -40°F to +250°F (-40°C to +121°C) | |
| Vibration | 15 G's @ 15-2000 Hz | |
| Rated Voltage | 12 Volt | 24 Volt |
| | Minimum Input Voltage | 9 VDC 18 VDC |
| | Rated Jump Start Voltage (1 cycle/min for 10 min) | 24 VDC 36 VDC |
| Reverse Polarity Protection | None | |
| Weight | Approx. 4 oz. (113 g) | |

7-Wire SSR Coil Commander®

Provides the functionality of an internally switched solenoid when used with a 4-wire externally switched solenoid. Eliminates the need for a separate solenoid relay.



Features:

- Prevents solenoid burnout due to engine over cranking or misadjustment of linkage by limiting the pull coil ON time
- Potted and sealed solid-state electronics
- Separate mounting bracket not required
- Stand alone plug-in or factory assembled to solenoid
- Patented

Order Information:

Stand Alone Modules

| ORDER NO. | Rated Voltage | Max. Current @ 68°F (20°C) | Terminations To System Harness | Terminations To Solenoid |
|-------------------|---------------|-------------------------------|--|--|
| SA-4690-12 | 12 VDC | 70 A | Leads | Leads |
| SA-4690-24 | 24 VDC | 40 A | Leads | Leads |
| SA-4691-24 | 24 VDC | 60 A | Leads | Leads |
| SA-4727-12 | 12 VDC | 86 A | Packard Weather Pack Housing No. 12020827 | Packard Weather Pack Housing No. 12020832 |
| SA-4727-24 | 24 VDC | 56 A | Packard Weather Pack Housing No. 12020827 | Packard Weather Pack Housing No. 12020832 |

Built-in Modules

Contact Woodward for factory assembled units.

Minimum quantities required for non-standard configurations. Contact factory for details.

E.E.C. Directive Compliance: All parts supplied by Woodward are classified as components, and therefore are not "CE" marked. Please contact factory direct for details on specific product compliance with 89/336/EEC and 89/392/EEC directives.

7-Wire SSR Coil Commander®

TERMINATION CONNECTIONS

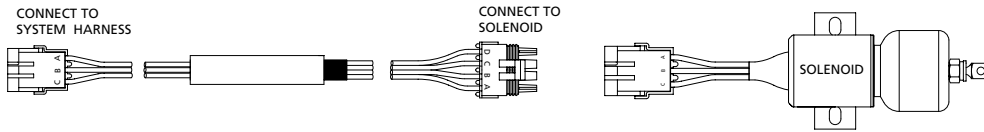

SSR ELECTRIC SHUTOFF

SSR electric shutoff for use with externally switched solenoids and to replace or eliminate a second solenoid relay

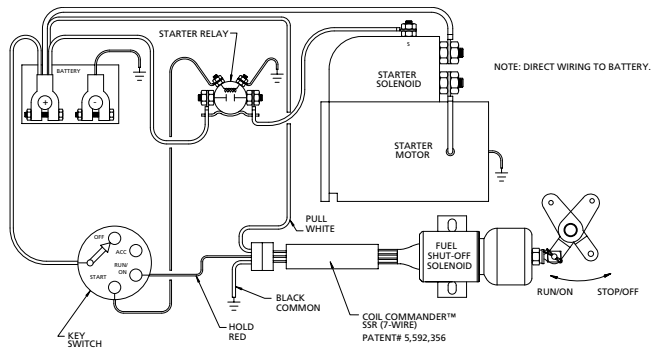

SSR THROTTLE/CHOKE SOLENOID

SSR throttle/choke solenoid eliminates need for mechanical relay

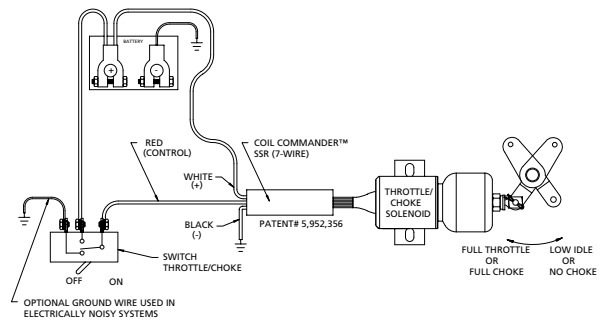

DIMENSIONS

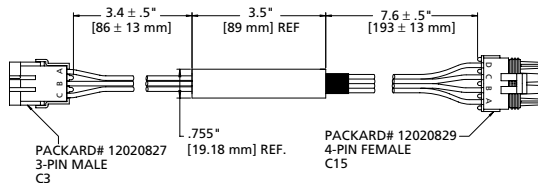

Note: Coil Commanders® will reduce the available pull coil voltage by approximately ½ to 1 volt.

Specifications:

| | | |
|-----------------------------|--------------------------------------|---------------|
| Temperature | -40°F to +250°F (-40°C to +121°C) | |
| Vibration | 15 G's @ 15-2000 Hz | |
| Rated Voltage | 12 Volt | 24 Volt |
| | Minimum Input Voltage | 9 VDC 18 VDC |
| | Rated Jump Start Voltage (<5 min) | 24 VDC 48 VDC |
| Reverse Polarity Protection | None | |
| Weight | Approx. 4 oz. (113 g) | |

PCTM Modules

Pull coil timer modules protect externally switched solenoids by limiting the pull coil ON time. Use of a PCTM enhances solenoid performance by providing functionality of an internally switched solenoid but with greater durability and reliability.



Features:

- 3- and 6-wire configurations for externally switched solenoids
- Can be mounted in any orientation or location
- Potted and sealed solid-state electronics
- Corrosion resistant

Order Information:

| ORDER NO. | Wire Configuration | Rated Voltage | Terminations To System Harness | Terminations To Solenoid |
|-------------------|--------------------|---------------|---|---|
| SA-4092-12 | 3-Wire | 12 VDC | Leads | Leads |
| SA-4092-24 | 3-Wire | 24 VDC | Leads | Leads |
| SA-4094-12 | 3-Wire | 12 VDC | Packard Weather Pack Housing No. 12020827 | Packard Weather Pack Housing No. 12020827 |
| SA-4094-24 | 3-Wire | 24 VDC | Packard Weather Pack Housing No. 12020827 | Packard Weather Pack Housing No. 12020827 |
| SA-4220-12 | 6-Wire | 12 VDC | Leads | Leads |
| SA-4220-24 | 6-Wire | 24 VDC | Leads | Leads |
| SA-4222-12 | 6-Wire | 12 VDC | Packard Weather Pack Housing No. 12010717 | Packard Weather Pack Housing No. 12015793 |
| SA-4222-24 | 6-Wire | 24 VDC | Packard Weather Pack Housing No. 12010717 | Packard Weather Pack Housing No. 12015793 |
| SA-4224-12 | 6-Wire | 12 VDC | Leads | Packard Weather Pack Housing No. 12020827 |
| SA-4224-24 | 6-Wire | 24 VDC | Leads | Packard Weather Pack Housing No. 12020827 |

Minimum quantities required for non-standard configurations. Contact factory for details.

E.E.C. Directive Compliance: All parts supplied by Woodward are classified as components, and therefore are not "CE" marked. Please contact factory direct for details on specific product compliance with 89/336/EEC and 89/392/EEC directives.

PCTM Modules

3-Wire Pull Coil Timer Module

DIMENSIONS

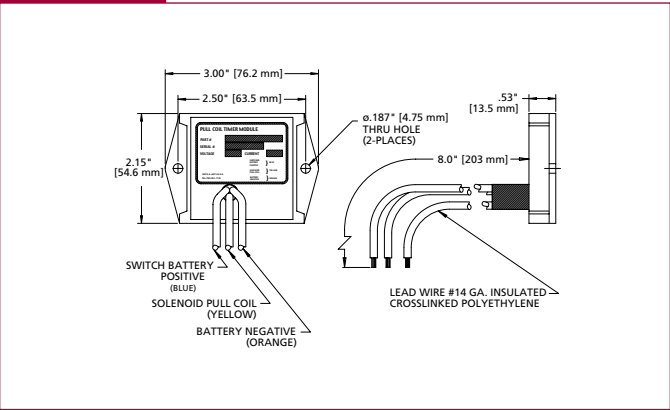

WIRING DIAGRAM

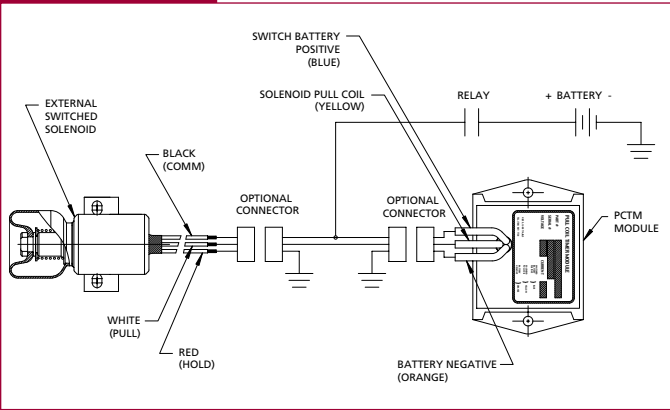

6-Wire SSR Pull Coil Timer Module

DIMENSIONS

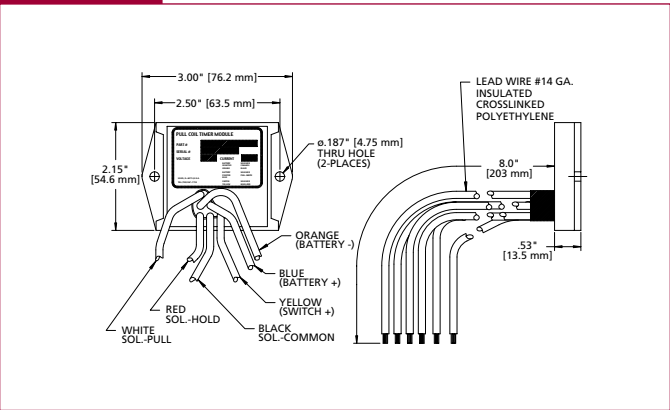

WIRING DIAGRAM

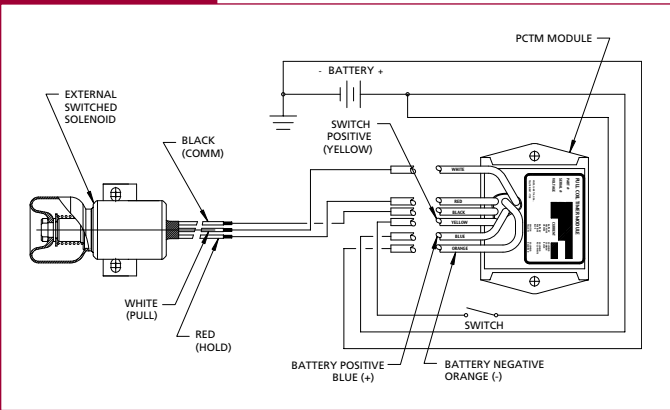

Note: PCTM's will reduce the available pull coil voltage by approximately 1/2 to 1 volt.

Specifications:

| | |
|----------------|--|
| Temperature | -40° F to +185° F (-40° C to +85° C) |
| Input Voltage | 12 VDC (30 VDC jump start) 24 VDC (57 VDC jump start) |
| Pull Current | 70 A @ 12 VDC 56 A @ 24 VDC |
| Vibration | 15 G's @ 15-2000 Hz |
| Maximum Cycles | 3 cycles/minute continuous |
| Energized Time | 0.5 seconds |

Specifications are for reference only.

Hardware

- Solenoid spring swivel
- In-line swivel
- Solenoid end cap
- Clevis yoke
- Clevis yoke bead chain assemblies
- PVC terminal protector
- Spherical rod end
- Connectors



Solenoid Spring Swivel

- Provides a 12° rotational movement to compensate for minor misalignment between solenoid and linkage, and allows up to .25" overtravel
- Male and female connectors rotate 360° for easy installation
- "L" dimension 3.0" when using 1/4-28 or M6 male; 3.25" when using 5/16-24 male

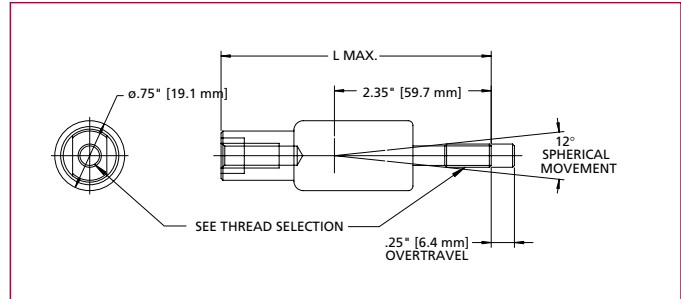

| ORDER NO. | Solenoid Model No. | Optional Return Spring |
|-------------------|--------------------|------------------------|
| SA-3157 - () () | 1502-1504-1753 | No |
| SA-3158 - () () | 1502-1504-1753 | Yes |
| SA-3159 - () () | 1751-2001-2003 | No |
| SA-3160 - () () | 1751-2001-2003 | Yes |

Male End of Swivel Thread Selection

A
1/4-28

C
5/16-24

E
M6

Female End of Swivel Thread Selection

B
1/4-28

D
5/16-24

F
M6

When you order: You will need to provide the male and female swivel thread selection

In-line Swivel

Compensates for possible misalignment between rigid linkage and solenoid plunger

| ORDER NO. | Mounting Thread |
|-----------|-----------------|
| SA-4049 | 1/4-28 |
| SA-4050 | M6 x 1 |

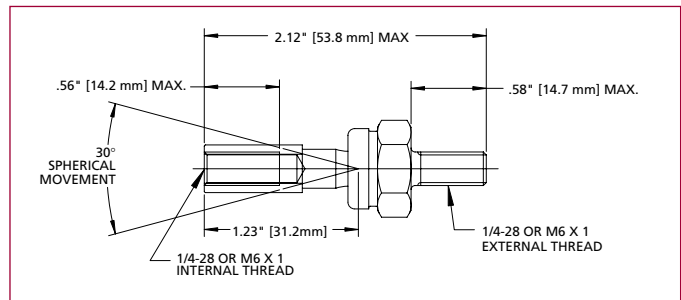

Solenoid End Cap

- Hypalon® rubber end cap thoroughly seals solenoid from contaminants such as water, oil, chemicals and salts
- Sized for 1500, 1750, and 2000 series solenoids

®Hypalon is a registered trademark of DuPont Dow Elastomers.

| ORDER NO. | Solenoid Model No. |
|-----------|--------------------|
| SE-5601 | 1500 Series |
| SE-5614 | 1750 Series |
| SE-5559 | 2000 Series |

Clevis Yoke

For use in customer designed linkage assemblies

| ORDER NO. | Mounting Thread |
|-----------|-----------------|
| SA-0008-A | 1/4-28 |

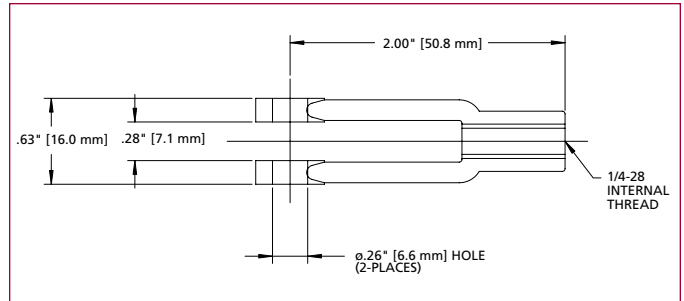

Clevis Yoke Bead Chain Assemblies

Used whenever a flexible connection is required, such as pulling a throttle lever on a gasoline engine

| ORDER NO. | Mounting Thread |
|-----------|-----------------|
| SA-0293-B | 1/4-28 |

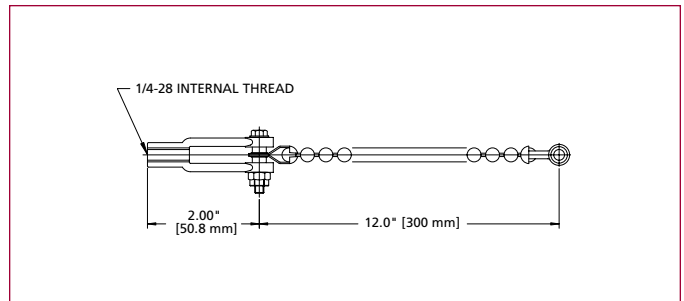

PVC Terminal Protector

- For internally switched solenoids with terminals
- Fits over solenoid cap to protect terminals from accidental shorting
- Available in end or side termination

| ORDER NO. | Termination |
|------------|-------------|
| SA-2968 | End |
| SA-2968-UK | Side |

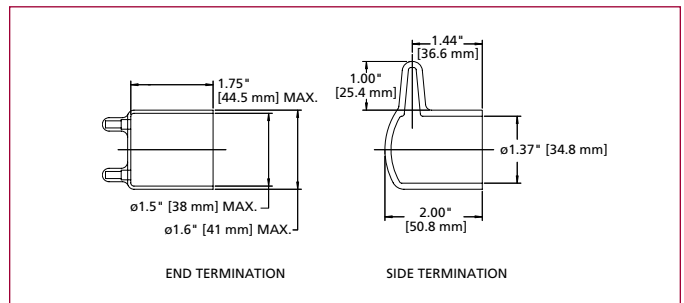

Spherical Rod End

- Heavy duty, low friction, nylon race ball joints for connecting solenoid linkage to fuel pump levers
- Available in male and female options

| ORDER NO. | Body | Stud |
|-----------|-----------------|-----------------|
| SA-4280 | Internal 1/4-28 | None |
| SA-4188 | Internal 1/4-28 | External 1/4-28 |
| SA-4232 | External 1/4-28 | External 1/4-28 |

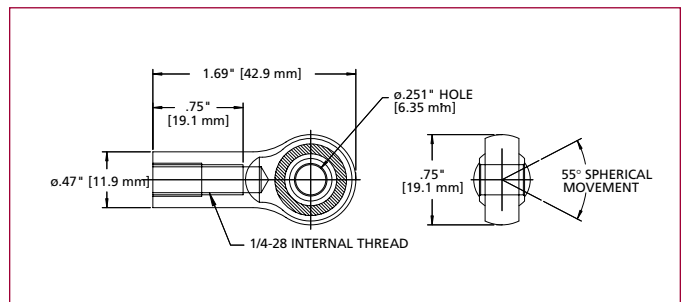

Connectors

- For externally switched solenoids with leads
- Special materials and seals are used to allow the connector to withstand extreme temperature and moisture conditions
- For ordering information contact Woodward

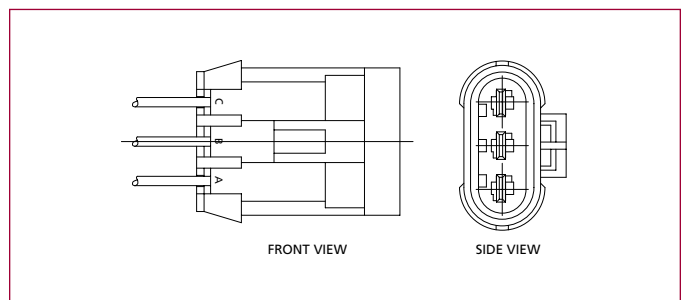

Shutdown Kits

Safe, dependable shutdown systems fit a range of engines and fuel injection pump governors. Designed for ease of installation and maintenance, kits contain solenoid and all mounting hardware for attachment to the governor housing.

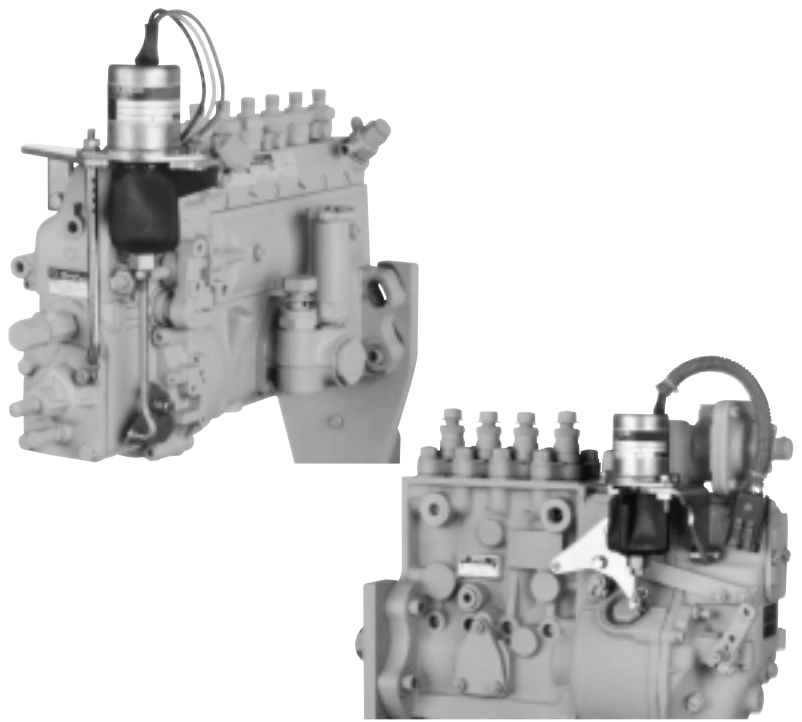

Features:

- Hold coil designed for continuous duty operation under the most severe temperature and vibration conditions
- Brass liner plunger bore for long life
- Plunger hard chrome plated for smooth, reliable, wear-resistant operation
- Plated steel solenoid, bracket, linkage, lever and hardware for corrosion resistance
- Available in 12 and 24 volt models

Kits Available:

- RQV-K Type Bosch Kit
- RSV Type Bosch Kit
- Kubota Kit 1A (62.2 mm series engines)
- Kubota Kit 3A (70 and 82 mm series engines)
- Mitsubishi L Series Kit
- RSV Type Zexel Nippondenso Kit

- Optional Packard Weather Pack, or Metri-Pack sealed connectors (RQV-K Bosch Kit includes Packard Weather Pack connector)
- Mounting hardware included for fast, easy installation
- Kits contain the properly selected solenoid and return spring for running and stopping engines under all conditions
- Solenoids are sized according to deration for hot temperature and low voltage

Shutdown Kits

Specifications:

| | |
|---------------------|--|
| Solenoid | 3-wire externally switched (ES) solenoid Internally switched solenoid also available on Kubota and RSV-Bosch kits |
| Rated Voltage | 12 or 24 VDC |
| Ambient Temperature | -40°F to +250°F (-40°C to +121°C) |
| Weight | Approx. 3.0 lbs (1.4 kg) |

| Engine Series | Voltage | Pull Current | Hold Current |
|----------------------------------|---------|--------------|--------------|
| RQV-K Bosch | 12 | 55 A | 1.1 A |
| | 24 | 29 A | 0.6 A |
| RSV Bosch | 12 | 46 A | 1.1 A |
| | 24 | 25 A | 0.5 A |
| Kubota 1A (62.2 mm series) | 12 | 33 A | 0.8 A |
| | 24 | 18 A | 0.4 A |
| Kubota 3A (70 & 82 mm series) | 12 | 46 A | 1.1 A |
| | 24 | 25 A | 0.5 A |
| Mitsubishi L | 12 | 46 A | 1.1 A |
| RSV Zexel Nippondenso | 12 | 55 A | 1.1 A |
| | 24 | 29 A | 0.6 A |

Solenoid Shutdown Systems

Specifications are for reference only.

Shutdown Kits

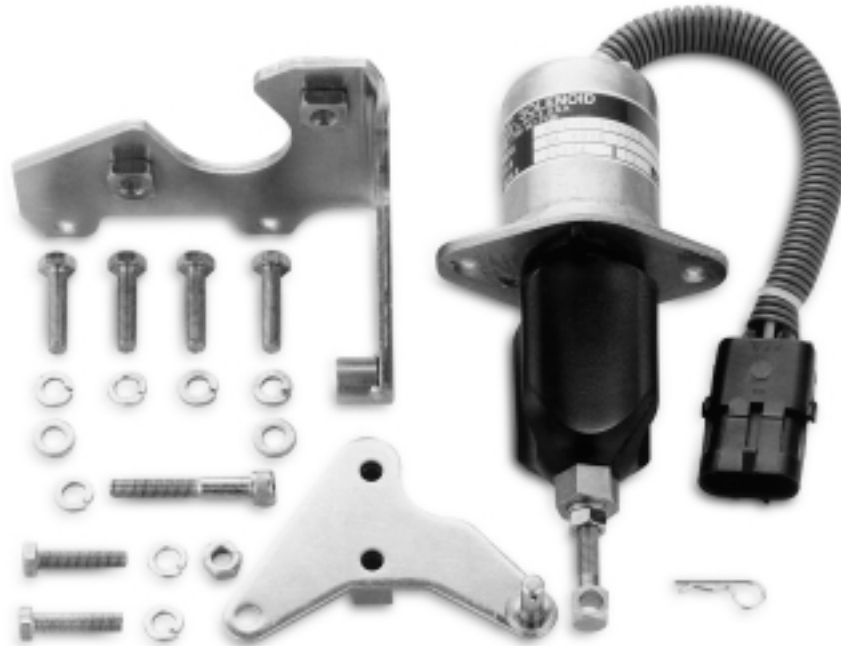

RQV-K Bosch Kit

- Installs on a variety of engines using Bosch pumps with RQV-K governor
- 1752ES solenoid has built-in Packard Weather Pack connector (Housing No. 12020827)

| ORDER NO. | Solenoid Model | Voltage |
|------------|----------------|---------|
| SA-4026-12 | 1752ES | 12 VDC |
| SA-4026-24 | 1752ES | 24 VDC |

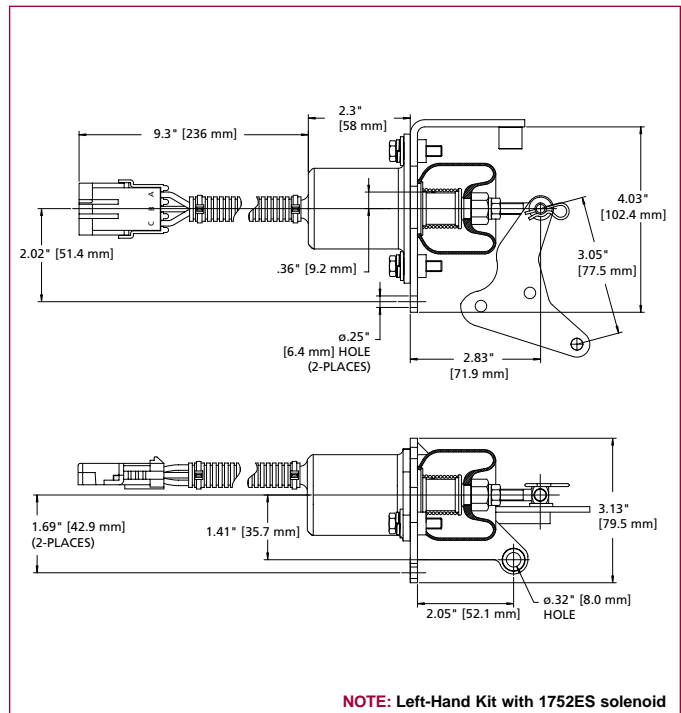

Shutdown Kits



RSV Bosch Kit

- Installs on a variety of engines and Bosch Models A, MW, and P pumps with RSV governor
- Right- or left-hand mounting styles

| ORDER NO. Right-Hand | Solenoid Model | Voltage |
|-------------------------|----------------|---------|
| SA-3799-12 | 1751ES | 12 VDC |
| SA-3799-24 | 1751ES | 24 VDC |
| SA-3800-12 | 1751 | 12 VDC |
| SA-3800-24 | 1751 | 24 VDC |

| ORDER NO. Left-Hand | Solenoid Model | Voltage |
|------------------------|----------------|---------|
| SA-3742-12 | 1751ES | 12 VDC |
| SA-3742-24 | 1751ES | 24 VDC |
| SA-3765-12 | 1751 | 12 VDC |
| SA-3765-24 | 1751 | 24 VDC |

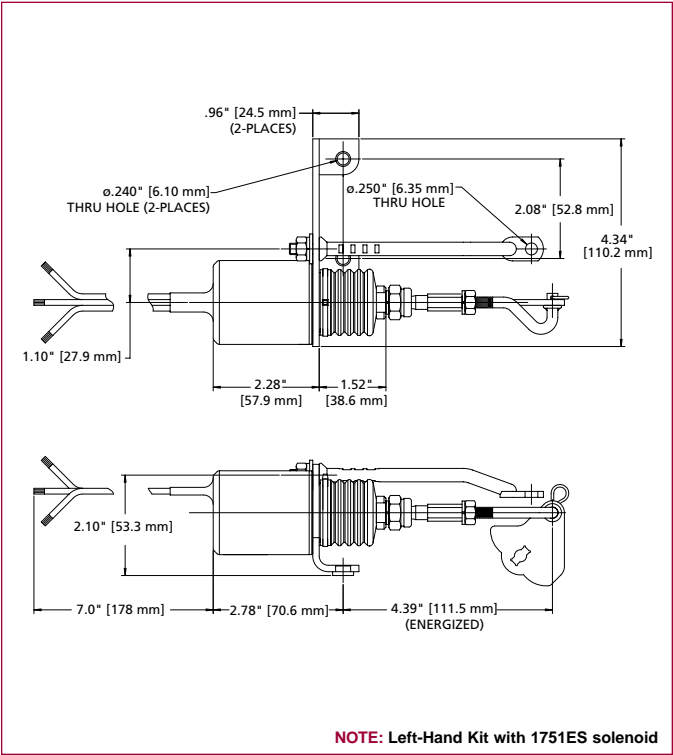

Shutdown Kits

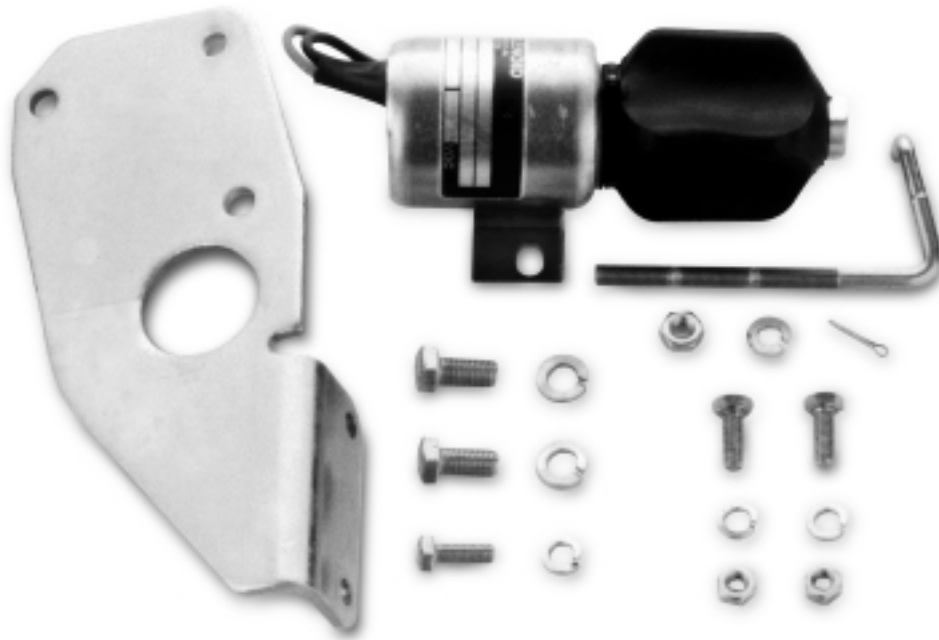

Kubota 1A Kit (62.2 mm series engines)

- Installs on Kubota 62.2 mm series engines
- Also available as hardware kit without 1753 solenoid

| ORDER NO. | Solenoid Model | Voltage |
|-----------------------------------|----------------|---------|
| SA-4268-12 | 1753 | 12 VDC |
| SA-4269-12 | 1753ES | 12 VDC |
| SA-4270 (Hardware only) | — | — |

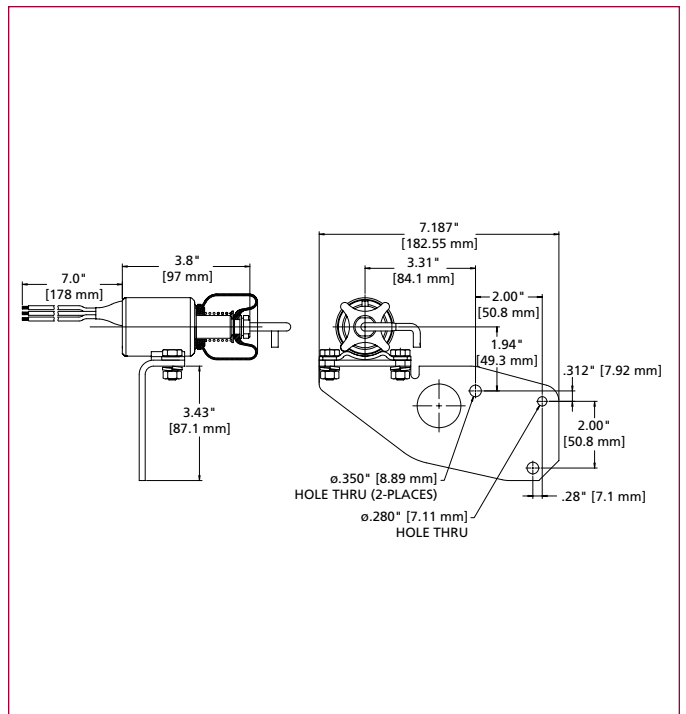

Shutdown Kits

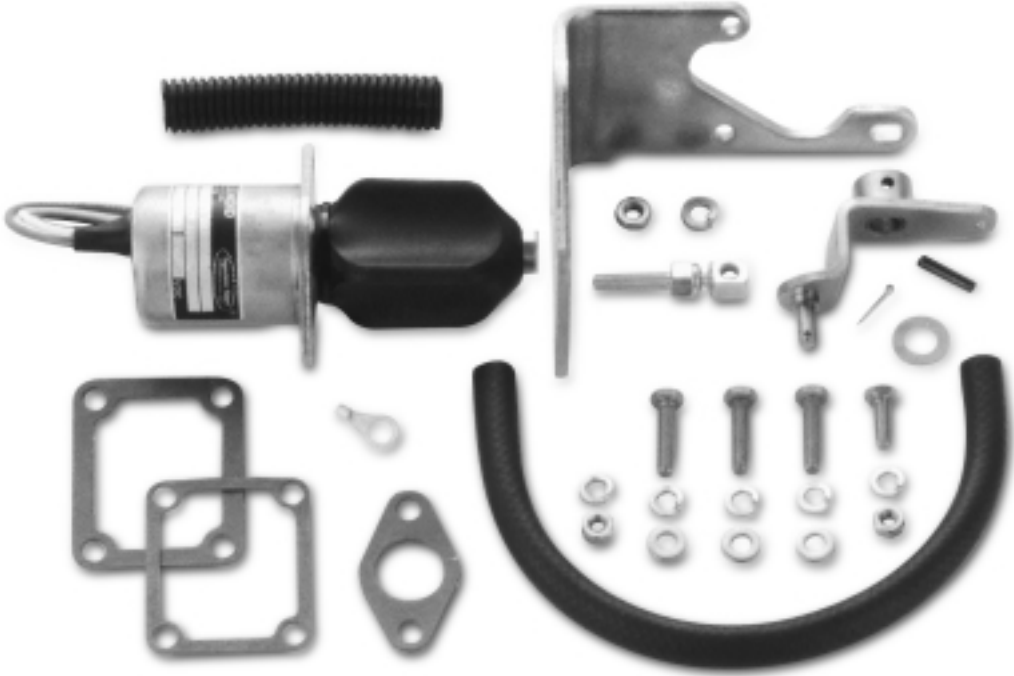

Kubota 3A Kit (70 & 82 mm series engines)

- Installs on Kubota 70 and 82 mm series engines
- Also available as hardware kit without 1751 solenoid

| ORDER NO. | Solenoid Model | Voltage |
|----------------------------|----------------|---------|
| SA-4259-12 | 1751 | 12 VDC |
| SA-4260-12 | 1751ES | 12 VDC |
| SA-4260-24 | 1751ES | 24 VDC |
| SA-4264 (Hardware only) | — | — |

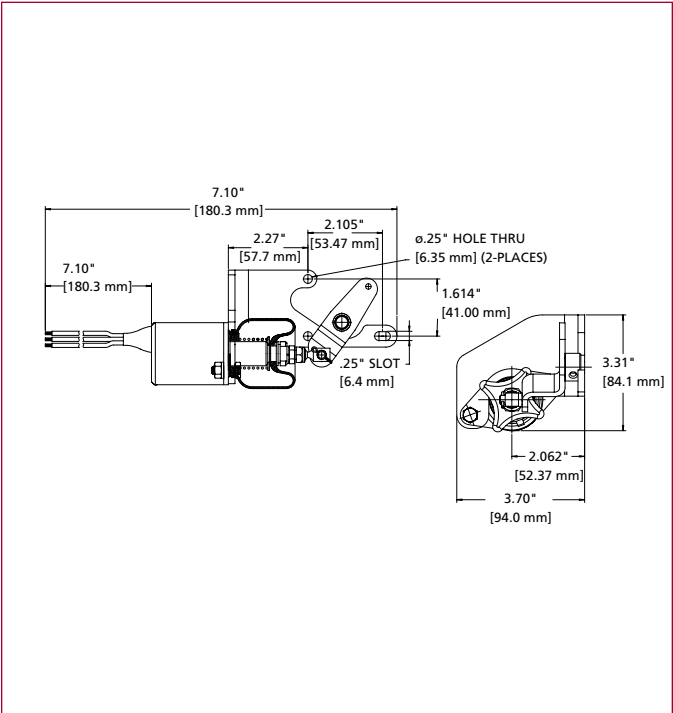

Shutdown Kits



Mitsubishi L Kit

- Installs on Mitsubishi "L" Series engines directly into pump with no external linkage

| ORDER NO. | Solenoid Model | Voltage |
|-----------|----------------|---------|
| SA-3725 | 1751ES | 12 VDC |

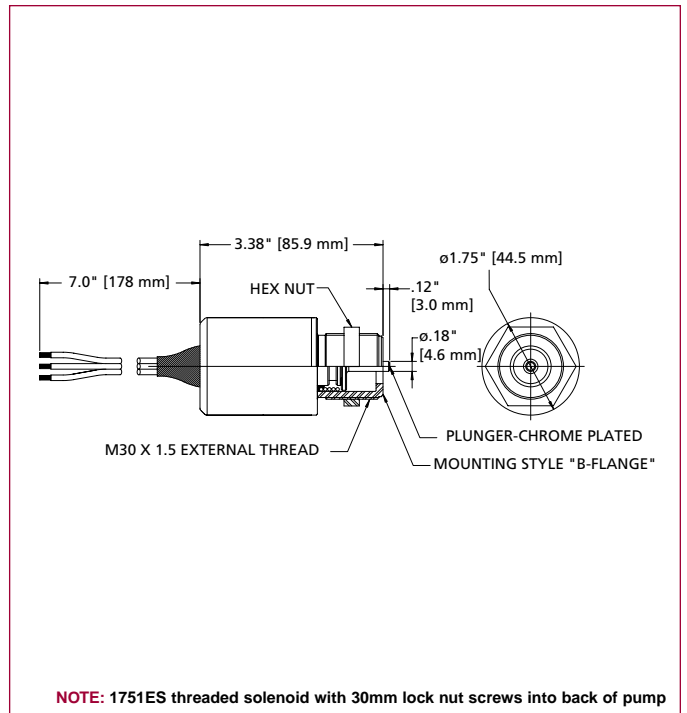

Shutdown Kits



RSV Zexel Nippondenso

- Installs on a variety of engines using Zexel or Nippondenso pumps with RSV governor
- Right- or left-hand mounting styles

| ORDER NO. Right-Hand | Solenoid Model | Voltage |
|-------------------------|----------------|---------|
| SA-3999-12 | 1752ES | 12 VDC |
| SA-3999-24 | 1752ES | 24 VDC |

| ORDER NO. Left-Hand | Solenoid Model | Voltage |
|------------------------|----------------|---------|
| SA-4014-12 | 1752ES | 12 VDC |
| SA-4014-24 | 1752ES | 24 VDC |

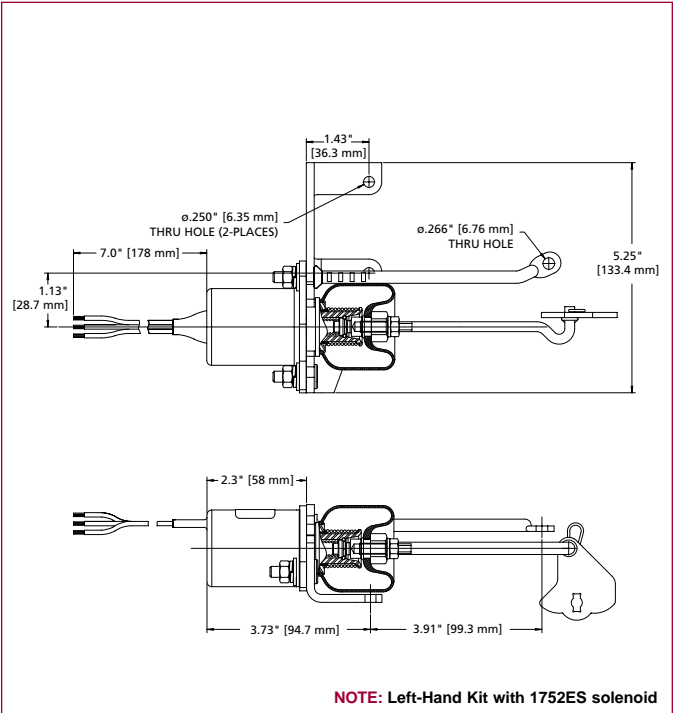

Shutdown Solenoid Kit

Fuel shutdown solenoid mounts closely above the front gear housing behind the fan on Kubota D722 & Z482 engines.

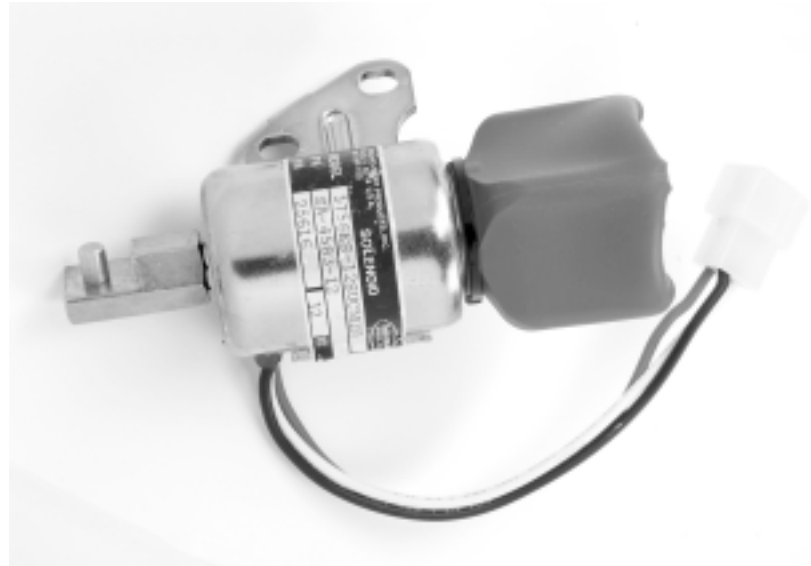

Features:

- Energized to run, fail-safe operation
- Hold coil designed for continuous duty operation under the most severe temperature and vibration conditions
- Brass liner plunger bore for long life
- Plunger hard chrome plated for smooth, reliable, wear-resistant operation
- Plated steel solenoid, bracket, linkage, lever and hardware for corrosion resistance
- Available in 12 and 24 volt models
- Mounting hardware included for fast, easy installation

Order Information:

| ORDER NO. | Solenoid | Voltage |
|-------------------|----------|---------|
| SA-4899-12 | 1756ES | 12 VDC |
| SA-4899-24 | 1756ES | 24 VDC |

Kubota Shutdown Lever:

Engine must be equipped with proper shutdown lever in order to install the shutdown solenoid. Order appropriate part number from Kubota.

| PART NO. | Engine Production Date* |
|--------------------|-------------------------|
| 16851-57720 | Before April, 2001 |
| 16851-57723 | After April, 2001 |

*Contact Kubota with engine serial number

E.E.C. Directive Compliance: All parts supplied by Woodward are classified as components, and therefore are not "CE" marked. Please contact factory direct for details on specific product compliance with 89/336/EEC and 89/392/EEC directives.

Shutdown Solenoid

KUBOTA D722 & Z482

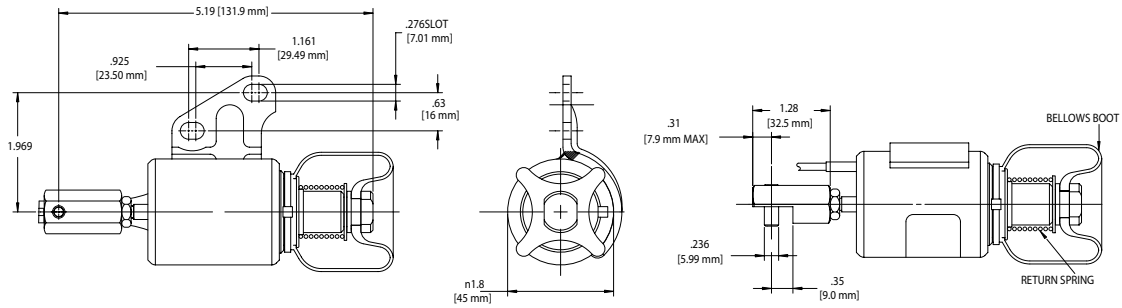

Specifications:

| | |
|---------------------|--------------------------------------|
| Rated Voltage | 12 or 24 VDC |
| Ambient Temperature | -40°F to +250°F (-40°C to +121°C) |
| Weight | Approx. 1.8 lbs (0.8 kg) |

| Engine Type | Voltage | Pull Current | Hold Current |
|--------------------|---------|--------------|--------------|
| Kubota D722 & Z482 | 12 | 46 A | 1.1 A |
| | 24 | 25 A | 0.5 A |

Specifications are for reference only.

ESS Basics

In 1932, Woodward introduced the first system to monitor speed. Over the years, our line of speed switches has broadened to include a wide range of electronic systems for many different markets.



Typical electronic speed switch applications include:

| | |
|---------------------------------|---|
| Generator Sets | Speed switches commonly used for crank disconnect and engine overspeed protection, which also protects the generator. |
| Starter Motors | A speed switch can detect starting speed and disengage the cranking motor to prevent damage. |
| Engines | The speed switch detects the critical speed above which engines should not be operated. Engines and motors suffer damage if operated at excessive speeds. By preventing the engine from developing excessive RPM's, the speed switch protects gears, transmissions, pumps, power takeoffs, etc. |
| Conveyors | Underspeed can also be a source of danger. It is often desirable to shut down a motor, an engine or a piece of equipment if the speed falls below a predetermined RPM. For example, conveyors may jam, compressors freeze, belts and drives break, lugging motors stall at critical times, motor windings overheat. |
| Bus Doors | Should an operator of buses require positive control to prevent the rear door from opening before the bus comes to stop, a Woodward speed system combined with a Mini-Gen® signal generator would provide the control automatically. |
| PTO Protection | Vehicles equipped with hydraulic power take-offs protect their systems by using a Woodward speed switch to control the activation speed. |
| Magnetic Brake Retarders | A Woodward speed switch and Mini-Gen® signal generator are used to monitor road speed and control the retarder activation and deactivation to save the battery. |
| Transmissions | A Woodward speed switch can be used as a shift inhibitor to assure the proper transmission shifting. |

Understanding the Electronic Speed Switch

| | |
|--------------------------------|--|
| What is a Speed Switch? | <ul style="list-style-type: none"> • Electronic device that senses rotational motion and speed • Can be set to switch a load or control device |
| How Does it Work? | <ul style="list-style-type: none"> • Obtains signal from sensor device (magnetic pickup, Mini-Gen signal generator, alternator or ignition coil) in the form of a frequency • Frequency is monitored electronically within the switch • When the speed or frequency reaches the desired setting or set point, the output relay tied into the control circuit is energized or switched |

Selecting a Speed Switch

In selecting the best speed switch for controlling a particular application, the following factors should be considered:

| | |
|---|---|
| Number of Switch Points | Most applications require only 1 or 2 switch points, some models offer 3-4 points. |
| Frequency Range of Application, Setpoints, and Signal Source | The frequency range of the application and setpoints are dependent upon the selection of the signal source, which in turn depends upon the operating speed and physical mounting limitations. |

Signal Source Options

The variety of signal sources which may be used with most SSPI switches include:

| | |
|---|---|
| <p>Magnetic Pickup Commonly used for higher speed applications. The output is a function of the "gap" between the pickup and the gear tooth and the peripheral velocity of the gear.</p> | $\text{Setpoint Frequency} = \frac{\text{No. of Gear Teeth} \times \text{Engine RPM Setpoint}}{60}$ <p>In Hertz</p> |
| <p>Mini-Gen® Signal Generator Designed to provide outstanding signal output at speeds as low as 20 RPM.</p> | $\text{Setpoint Frequency} = \frac{\text{Mini-Gen RPM at Engine RPM Setpoint}}{2}$ <p>In Hertz</p> |
| <p>Alternator Output Used in applications unable to accommodate a magnetic pickup or Mini-Gen signal generator.</p> | $\text{Setpoint Frequency} = \frac{\text{Pulley Ratio} \times \text{No. of Alt. Poles} \times \text{Engine RPM Setpoint}}{120}$ <p>In Hertz</p> |
| <p>Ignition Output Commonly used as a source for gasoline and natural gas type engines.</p> | $\text{Setpoint Frequency} = \frac{\text{No. of Cylinders} \times \text{Engine RPM Setpoint}}{120}$ <p>In Hertz</p> |

Basics

Setpoint Frequency

Each signal source produces a different Hertz setpoint frequency for identical engine RPM setpoints.

Example:

Required crank disconnect 300 RPM and overspeed of 2500 RPM. This 8-cylinder gas engine has an 80-tooth flywheel and an 8-pole alternator with a 2:1 pulley ratio.

| Signal Source | Crank Disconnect 300 RPM | Overspeed 2500 RPM |
|------------------------|---|---|
| Magnetic Pickup | $\frac{80 \times 300}{60} = 400 \text{ Hz}$ | $\frac{80 \times 2500}{60} = 3333 \text{ Hz}$ |
| Mini-Gen® | $\frac{300}{2} = 150 \text{ Hz}$ | $\frac{2500}{2} = 1250 \text{ Hz}$ |
| Alternator | $\frac{2 \times 8 \times 300}{120} = 40 \text{ Hz}$ | $\frac{2 \times 8 \times 2500}{120} = 333 \text{ Hz}$ |
| Ignition | $\frac{8 \times 300}{120} = 20 \text{ Hz}$ | $\frac{8 \times 2500}{120} = 166 \text{ Hz}$ |

Reset Requirements

There are four reset options available for resetting the speed switch:

| | |
|-------------------------|---|
| Automatic Reset | With the automatic reset option, the switch will automatically reset if the frequency of the input signal is lowered by 80% to 90% of the setpoint. |
| Electrical Latch | With the electrical latch option, the relay will energize (after the setpoint has been reached) and remain energized even if the input signal frequency has been lowered to 0 Hertz. The only way to reset the unit is to remove power. |
| Manual Reset | With the manual reset option, the switch is supplied with a reset button. By depressing this button, the unit will be reset. |
| Adjustable Reset | With the adjustable (automatic) reset option, the switch will automatically reset at the frequency determined by the setting of the supplied reset pot. By adjusting the potentiometer, the reset can be selected anywhere between 25% and 95% of the setpoint on the majority of models. |

Relay Operation

| | |
|-----------------------------|--|
| Standard Relay Logic | With power applied and a signal below the setpoint, the relay will remain de-energized until the setpoint is reached. At setpoint, the relay will be energized and remain energized until reset. |
| Reverse Relay Logic | With power applied and a signal below the setpoint, the relay will be energized and remain energized until the setpoint is reached. At setpoint or interruption of power, the relay will de-energize and remain de-energized until reset or power is reapplied. Reverse relay logic is commonly used as part of a fail-safe system to assure power is applied to the relay during operation. |

Typical Relay Operation

| Condition | Standard Relay Logic | Reverse Relay Logic |
|--------------------------------|---|---|
| Power Off | <pre> NO NC \ / C </pre> | <pre> NO NC / \ C </pre> |
| Power On | <pre> NO NC / \ C </pre> | <pre> NO NC \ / C </pre> |
| At Setpoint | <pre> NO NC \ / C </pre> | <pre> NO NC / \ C </pre> |
| At Reset | <pre> NO NC / \ C </pre> | <pre> NO NC \ / C </pre> |
| Loss of Power to Switch | <pre> NO NC \ / C </pre> | <pre> NO NC / \ C </pre> |

Power Requirements

Identify the power source variations. Determine the maximum and minimum voltage as well as transients of the power source.

Load Requirements

Determine the voltage and current switching requirements of the external control circuit. Consider the inductive or resistive nature of the load. If load currents in excess of 10 amps are expected, interface relays should be used.

Environmental Conditions

Identify the environmental conditions. Determine the maximum and minimum ambient temperatures. Also consider vibration and shock.

Standard Features and Options

| | |
|-------------------------------|---|
| Verify or Test Circuit | Standard on many models, which enables the testing of the complete system while the engine is operating at a safe speed. When used, the switch will trip at approximately 67% of the setpoint. |
| Signal Loss | If protection from possible loss of signal is desired, the ESSB offers optional broken signal lead protection by continuously monitoring for an open or high resistance in the signal source circuit. |
| Power Loss | If protection from "loss of power" to the electronic unit is desired, specify the reverse relay logic option. |
| Terminal Protection | Conduit covers and terminal protectors are available to eliminate exposed connections and danger from high voltage on select models. |

ESSB

Model ESSB electronic speed switch has many years of proven service. It is engineered to provide a wide variety of features and options including up to four switch points, adjustable reset, a selection of voltage inputs and tachometer output.



Features:

- Adjustable switch points
- Sealed NEMA 4 enclosure
- Transient and reverse polarity protection
- Precise repetitive speed switch points
- Automatic, manual or remote manual reset
- Power loss protection
- DC output for Model 30 Tach (1 mA)
- 8-40 VDC; 64 VDC; 100-140 VDC; or 100-130 VAC power
- Broken signal lead protection
- Standard or reverse relay logic
- Lockwire seal
- Conduit cover
- Vibration isolation kit accessory

Order Information: Complete the following model descriptions to build your Order No.

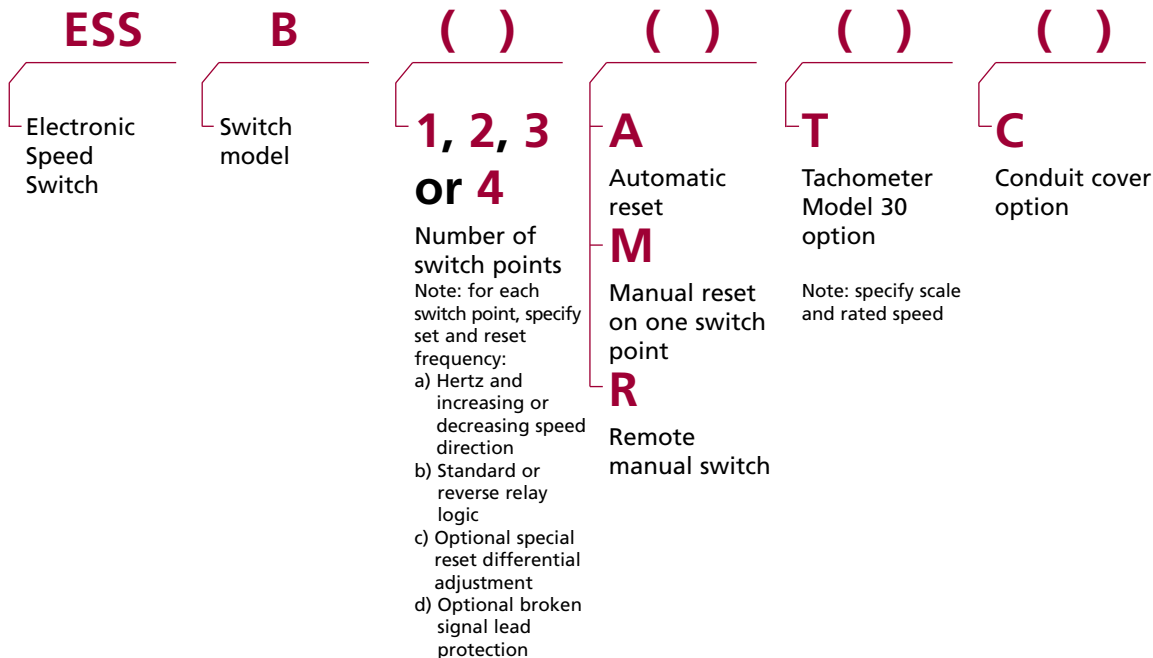

When you order: You will need to provide the power supply voltage

E.E.C. Directive Compliance: All parts supplied by Woodward are classified as components, and therefore are not "CE" marked. Please contact factory direct for details on specific product compliance with 89/336/EEC and 89/392/EEC directives.

FRONT VIEW

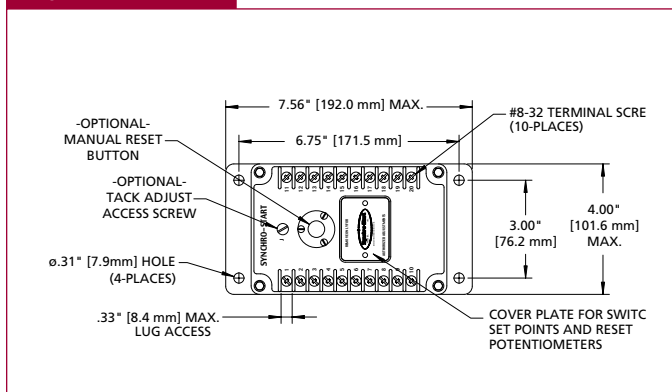

SIDE VIEW

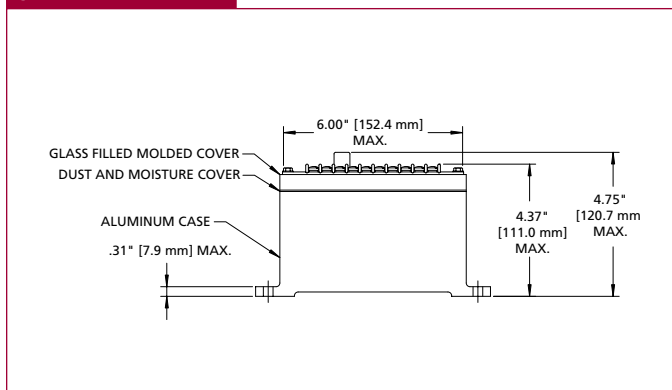

Electrical Specifications:

| | | |
|-----------------------------------|---|-----------------------------------|
| Power Input | 8-40 VDC 64 VDC 100-140 VDC 100-130 VAC | |
| Reverse Polarity Protection | 1000 VDC | |
| Maximum Current (2 ch. 80-40 VDC) | <u>12 Volt</u> 200 mA 50 mA | <u>24 Volt</u> 220 mA 60 mA |
| Signal Input | Minimum: 1.2 VRMS Impedance: 2K ohms | |
| Relay Contact Ratings | Resistive Load: 0.1 to 10 A 28 VDC Inductive Load: 0.1 to 8 A 28 VDC | |
| Overspeed Response Time | 100 milliseconds typical | |
| Setpoint Reset | Automatic: 80% to 90% of setpoint Automatic Adjustable: 50% to 98% of setpoint | |
| Setpoint Stability | 0.8% over voltage range and 0.01% per °F typical | |

Mechanical Specifications:

| | |
|-----------------------|---|
| Operating Temperature | -40 °F to + 185 °F (-40 °C to + 85 °C) |
| Vibration | 4 G's from 9 to 200 Hz |
| Shock | 4 foot drop test |
| Case | NEMA 4 high impact molded enclosure |
| Weight | 4.5 lbs (2 kg) |

Accessories

Vibration Isolator

The vibration isolator kit is recommended for mounting ESSB speed switches on or near engines wherever vibration exceeds 5 G's 20 to 500 Hertz. Proper installation will reduce vibration by as much as 80%.

Mounting studs are 1/4-20 x 5/8" permitting mounting on 1/4" thick plate.

ORDER NO.

SA-2214

Mounting Studs

1/4-20 x 5/8"



DISCONTINUED
Effective 09.01.03

ESSD

The ESSD speed switch is designed to provide overspeed or underspeed protection, crank disconnect, shift inhibiting on diesel engines, and brake retarding on trucks and buses.



Features:

- Economical single channel speed switch
- Compact, rugged construction
- Potted, solid state components
- Normally open or normally closed switch
- Adjustable reset
- Wide speed range from 20 RPM up to 10 kHz

Order Information: Indicate switch action to complete your Order No.

| ORDER NO. | Set Point Frequency Range Hertz | Signal Source Mini-Gen 44 Gauge | Signal Source Mini-Gen 37 Gauge | Signal Source Magnetic Pickup |
|-------------|---------------------------------------|---------------------------------------|---------------------------------------|-------------------------------------|
| SA-2657-() | >10 | X | | |
| SA-2658-() | 12.5 to 68 | X | | |
| SA-2659-() | 69 to 357 | | X | |
| SA-2660-() | 358 to 1330 | | X | X |
| SA-3316-() | 1331 to 3200 | | | X |
| SA-3317-() | 3201 to 8000 | | | X |

Switch
Action

NO

Normally
open

NC

Normally
closed

OA

Normally
open w/
adjustable
reset

CA

Normally
closed w/
adjustable
reset

E.E.C. Directive Compliance: All parts supplied by Woodward are classified as components, and therefore are not "CE" marked. Please contact factory direct for details on specific product compliance with 89/336/EEC and 89/392/EEC directives.

FRONT VIEW

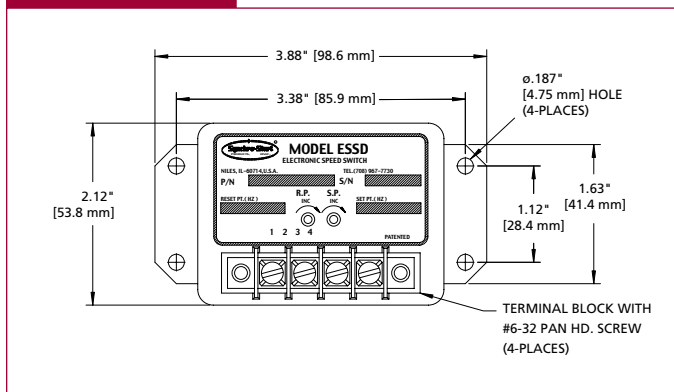

SIDE VIEW

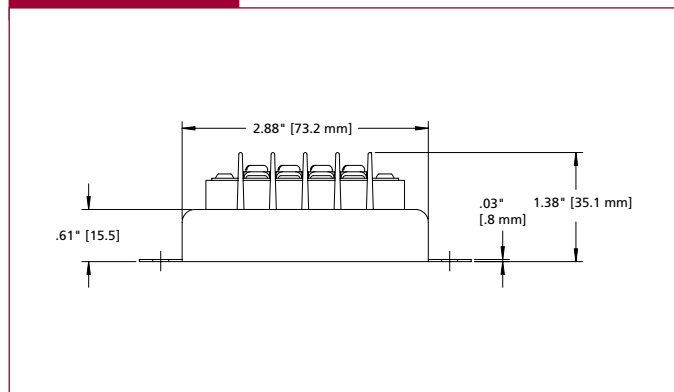

Electrical Specifications:

| | | |
|--|---|------------------------|
| Power Input | 10-30 VDC | |
| Maximum Current (2 ch.8-40 VDC) Standby | 12 Volt 3 mA | 24 Volt 6 mA |
| Signal Input | Minimum: 1.2 VRMS Impedance: 22K ohms (Nominal) | |
| Switching Capability | Maximum: 1 A DC continuous | |
| External Load Resistance | 12 VDC: 14 to 330 ohms 24 VDC: 28 to 1200 ohms | |
| Setpoint Reset | Automatic: | 70% to 90% of setpoint |
| | Automatic Adjustable: | 50% to 98% of setpoint |

Mechanical Specifications:

| | |
|-----------------------|--|
| Operating Temperature | -40°F to +185°F (-40°C to +85°C) |
| Vibration | 5 G's from 20 to 500 Hz |
| Shock | 4 foot drop test |
| Case | Metal drawn Potted electronics for environmental protection Nickel-plated terminals - humidity and salt spray resistant |
| Weight | .27 lbs (.12 kg) |

ESSE Series

Single or dual switches to monitor and control critical speed functions. Applications include crank disconnect or overspeed protection on diesel engines, transmission shift inhibiting, and PTO protection.

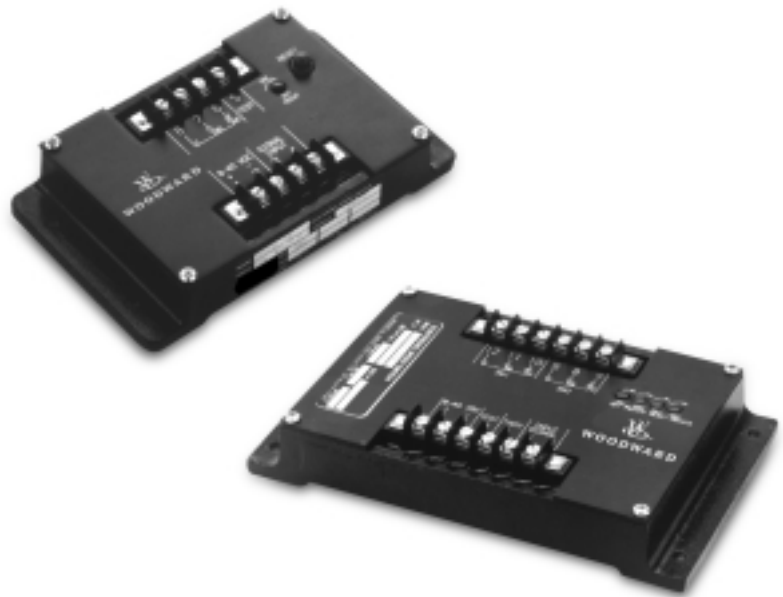

Features:

- Standard or reverse relay operation
- Field adjustable set and reset switch points
- High noise immunity
- Latch, automatic, manual or adjustable resets (automatic or latch are field selectable)
- Reverse polarity protection
- Mini-Gen® signal generator, magnetic pickup, alternator or ignition coil for signal input
- Test circuit (trips at 67% ± 10% of setpoint)
- Potted for in-field reliability, exposed applications, and hostile environments
- Field selectable setpoint range

Order Information: Complete the following model descriptions to build your Order No.

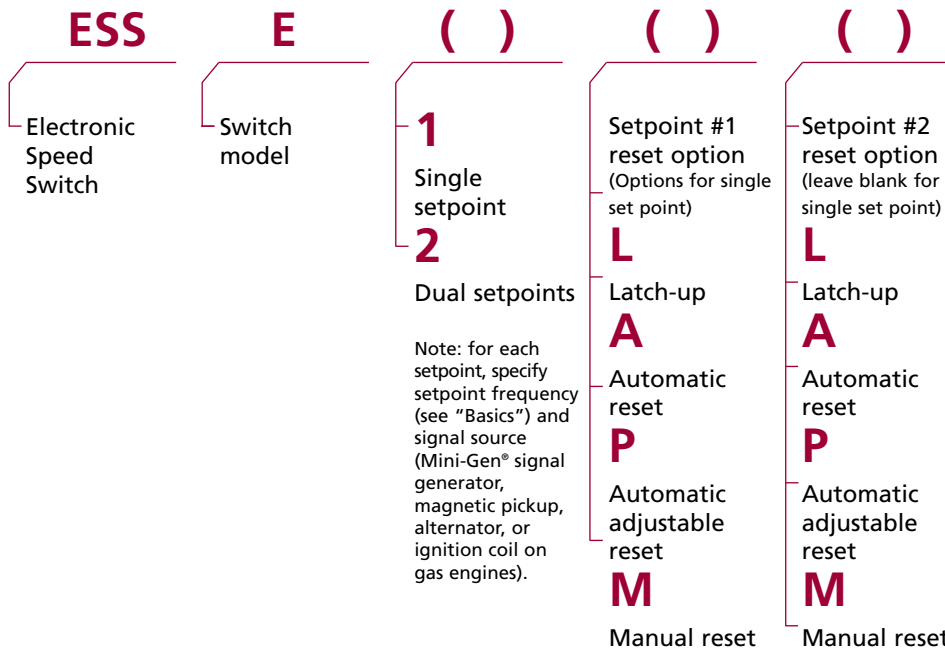

When you order: Also specify speed range 1 or 2 from the chart below.

| | Standard Inputs | Ignition Input |
|----------|-----------------|----------------|
| 1 | 80-2500 Hz | 10-250 Hz |
| 2 | 325-10,000 Hz | 20-500 Hz |

E.E.C. Directive Compliance: All parts supplied by Woodward are classified as components, and therefore are not "CE" marked. Please contact factory direct for details on specific product compliance with 89/336/EEC and 89/392/EEC directives.

ESSE Series

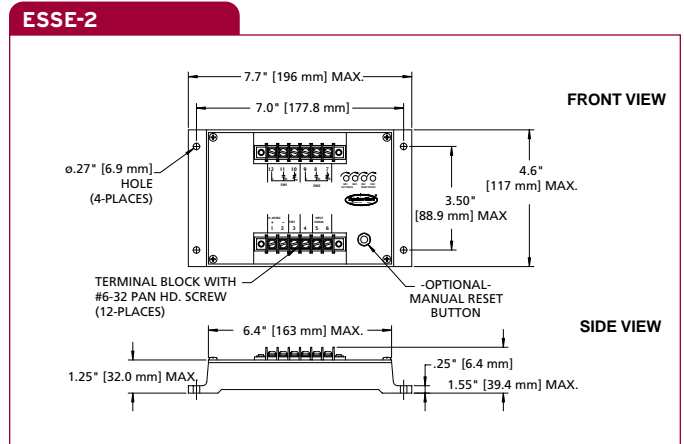
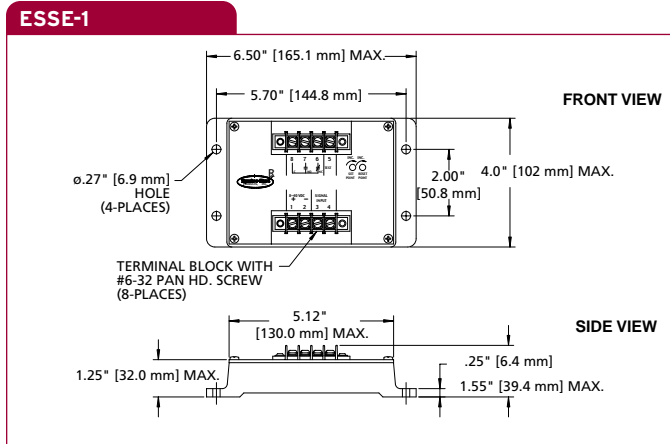

Electrical Specifications:

| | | |
|-----------------------------------|---|---------|
| Power Input | 8-40 VDC (40-80 VDC optional on ESSE-2) | |
| Power Supply Transient Protection | 900 volts for 100 microseconds (exponential decay) | |
| Reverse Polarity Protection | 1000 VDC | |
| Maximum Current for ESSE-1 | 12 Volt | 24 Volt |
| | Operating: 125 mA | 140 mA |
| | Standby: 30 mA | 45 mA |
| for ESSE-2 | 12 Volt | 24 Volt |
| | Operating: 200 mA | 220 mA |
| | Standby: 30 mA | 45 mA |
| Signal Input | Minimum: 1.2 VRMS | |
| | Maximum: 130 VRMS | |
| | Impedance: 33K ohms (nominal) | |
| Relay Contact Ratings | | |
| | Resistive Load: 0.1 to 10 A 28 VDC | |
| | Inductive Load: 0.1 to 8 A 28 VDC | |
| Overspeed Response Time | 100 milliseconds (typical) | |
| Setpoint Reset | Automatic (80% to 90% of setpoint) Automatic Adjustable (25% to 95% of setpoint) Electrical Latch Manual Reset | |
| Setpoint Stability | For an input voltage range of 9V to 40V and for a temperature range of +14 °F to +185 °F (-10 °C to +85 °C), the ESSE Series shall typically be less than 1% or 8 Hz, whichever is greater. The unit performs to -40 °F (-40 °C). | |

Mechanical Specifications:

| | | |
|-----------------------|---|-------------------------------------|
| Operating Temperature | -40 °F to +185 °F (-40 °C to +85 °C) | |
| Vibration | 4 G's from 20 to 500 Hz | |
| Shock | 4 foot drop test | |
| Case | Cast aluminum 1/4" wall thickness Potted electronics for environmental protection Nickel-plated terminals - humidity and salt spray resistant | |
| Weight | of ESSE-1 of ESSE-2 | 1.4 lbs (.5 kg) 1.9 lbs (0.9 kg) |

Specifications are for reference only.

EPS 1000

The EPS 1000 is a programmable, three-channel equipment protection module designed to perform a variety of functions simultaneously. It is especially suited for engine protection, sequenced operations, and critical timing applications. It can also be used for unattended engine starting using autocrank and glow plug functions.



Features:

- PC programmable, microprocessor based for accurate and stable set points
- Two-piece enclosure allows either recessed panel mounting or base mounting (Patent applied for)
- Front panel LED's provide instant visual data on operational status
- Three output channels for independent configuration of various actions
- Each channel can be configured in one of three modes:
 1. Speed Switch
 2. Autocrank Controller
 3. Glow Plug Controller
- Speed signal input is user selectable for magnetic pickup, ignition, or Hall Effect sensor
- Autocrank mode allows programming for crank time, rest time, and maximum crank attempts
- Glow plug mode controls glow plug ON time
- Test verify function permits testing of relay at 70% of set point (programmable 0 to 99% of set point)
- Normal or reverse relay logic is configurable by user
- Six switch inputs plus engine speed input provide versatile programming
- Protection switch inputs (EP) can be enabled at preset (programmable) RPM after preset time delay
- Two auxiliary outputs indicate status and fault codes
- Engine status indicator displays engine failure codes to aid in troubleshooting engine problems

Order Information:

| ORDER No. | Description |
|----------------|---|
| SA-4478 | EPS 1000 Module |
| SA-4479 | EPS Calibration Tool Kit Includes interface module, program diskette, RS-232 cable, and Operator's Manual |

E.E.C. Directive Compliance: All parts supplied by Woodward are classified as components, and therefore are not "CE" marked. Please contact factory direct for details on specific product compliance with 89/336/EEC and 89/392/EEC directives.

Electrical Specifications:

| | | |
|------------------------------------|--------------------------------------|----------------|
| Power Input | 9-30 VDC, reverse polarity protected | |
| Electromagnetic Compatibility | ISO 14982:1998/E | |
| EMI Immunity (ISO 14982:1998/E) | 30 V/M 20 MHz to 1000 MHz | |
| Nominal Operating Current | <u>12 Volt</u> | <u>24 Volt</u> |
| Operating: | 140 mA | 120 mA |
| Standby: | 25 mA | 40 mA |
| Relay Contact Ratings | 0.1 to 10 A @ 28 VDC | |
| Resistive Load: | 0.1 to 8 A @ 28 VDC | |
| Inductive Load: | 0.1 to 8 A @ 28 VDC | |
| Auxiliary Outputs | Aux 1 and Aux 2: 200 mA maximum | |

Mechanical Specifications:

| | |
|-----------------------|---|
| Operating Temperature | -40°F to +185°F (-40°C to +85°C) |
| Vibration | 4 G's from 40 to 2000 Hz |
| Shock | 10 G's @ 45 Hz |
| Case | UV, chemical resistant, and UL 94 V-0 flame retardant. Encapsulated for reliability against harsh environments |
| Calibration | Requires interface adapter and software for calibration setup. |
| Terminations | Euro style terminal block |
| Weight | .85 lbs (.386 kg) |

Unique, Patented Enclosure:

Two-part enclosure accommodates either panel or base mounting for convenient, clutter-free installation.

Case

- Lead wires to 21 terminals exit unobtrusively from bottom of case
- Terminal descriptions easily identified on side of case
- LED's and engine failure codes prominently displayed on front panel

Reversible Frame

- Snap ledges secure case to frame
- When attached to top of case, assembly can be installed below the surface in a cutout in the panel (panel mount)
- When attached to bottom of case, assembly can be mounted on top of panel surface (base mount). Built-in aperture allows a convenient exit for wires and/or connections.

PANEL MOUNT

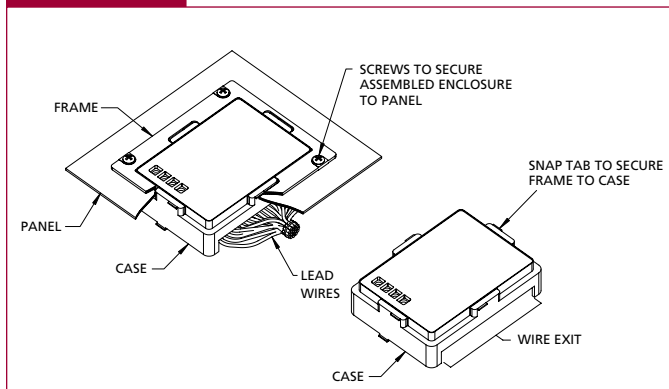

BASE MOUNT

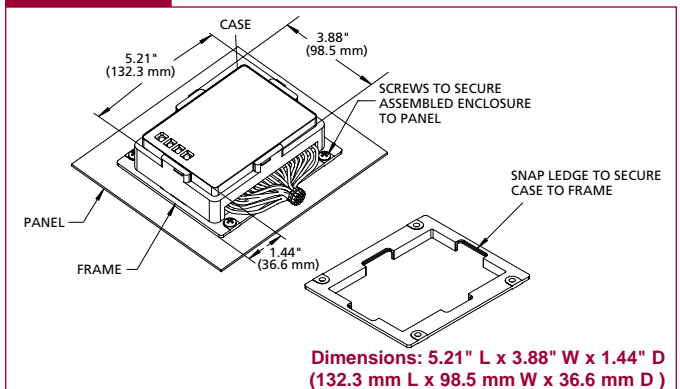

Specifications are for reference only.

Magnetic Pickups

Convert engine speed to an AC voltage. Compatible with Woodward electronic governing systems and speed switches



Features:

- No moving parts
- Self powered
- $\frac{5}{8}$ and $\frac{3}{4}$ thread sizes
- Withstands extreme temperature range
- Endures shock and vibration
- Choice of wire leads or cable connectors

Order Information:

Without Cable Assembly*

| ORDER NO. | Mounting Thread | Overall Length (mm) | Coil Resistance ohms @ 78°F | Inductance mH @ 1 KHz | Output Voltage Peak-to-Peak | Output Voltage VRMS |
|-----------------|-------------------|---------------------|-----------------------------|-----------------------|-----------------------------|---------------------|
| SA-2170 | $\frac{5}{8}$ -18 | 2.62" (66.6) | 144 to 230 | 85 | 17 | 6 |
| SA-2171A | $\frac{5}{8}$ -18 | 3.63" (92.2) | 144 to 198 | 85 | 17 | 6 |

With Cable Assembly

| ORDER NO. | Mounting Thread | Overall Length (mm) | Coil Resistance Ohms @ 78°F | Inductance mH @ 1 KHZ | Output Voltage Peak-to-Peak | Output Voltage VRMS |
|----------------|-------------------|---------------------|-----------------------------|-----------------------|-----------------------------|---------------------|
| SA-4423 | $\frac{3}{4}$ -16 | 3.00" (76.2) | 360 to 540 | 25 | 15 | 5.3 |
| SA-4424 | $\frac{5}{8}$ -18 | 3.00" (76.2) | 40 to 85 | 25 | 8 | 2.8 |

Operating Temperature: -65°F to 225°F (-54°C to 107°C)

Storage Temperature: -100°F to 225°F (-73°C to 107°C)

Test Conditions: Airgap: 0.015, Surface speed: 300 in/sec, Test wheel gear: 8 pitch, Load: 2.2k ohms.

*See facing page for ordering information

Specifications are for reference only.

E.E.C. Directive Compliance: All parts supplied by Woodward are classified as components, and therefore are not "CE" marked. Please contact factory direct for details on specific product compliance with 89/336/EEC and 89/392/EEC directives.

Magnetic Pickups

SA-2170

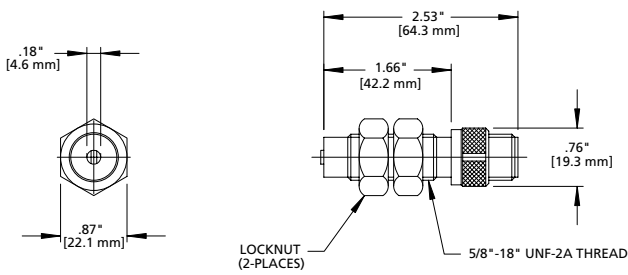

NOTE: Chisel Tip SA-2170 is suggested for flywheel teeth with very fine pitch

SA-4423

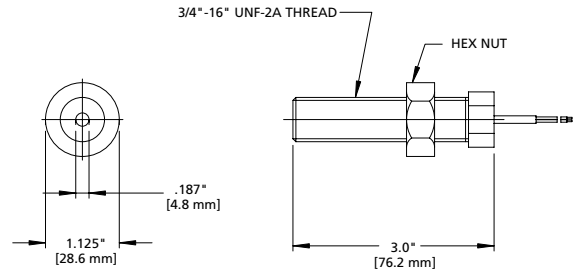

Two wires, open lead

SA-2171A

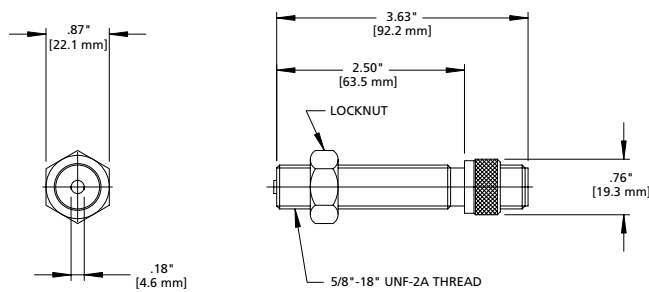

SA-4424

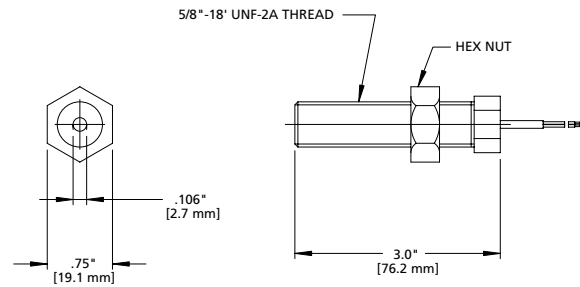

Two wires, open lead

Use Woodward magnetic pickups with electronic speed switches for the input signal normally obtained from a gear tooth. Models SA-4423 and SA-4424 come with cable assembly for connection to the speed switch. For connection of Models SA-2170 and SA-2171A, cable lengths from 3 to 50 feet are available.

Accessories

Connector and Cable Assembly

Used with SA-2170 and SA-2171A only.
Order separately.

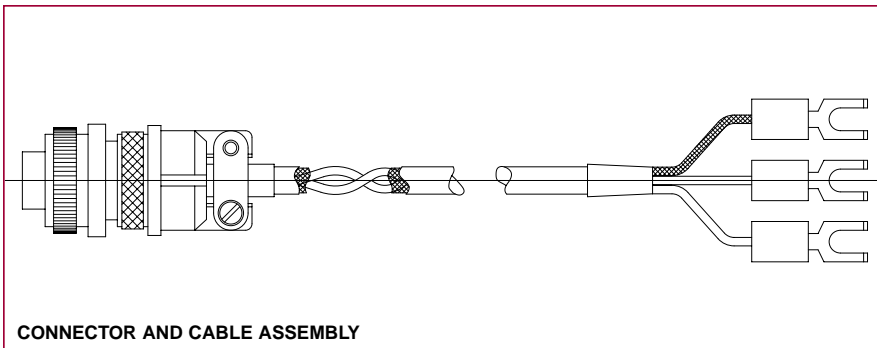

CONNECTOR AND CABLE ASSEMBLY

| ORDER NO. | Cable Length |
|--------------------|--------------|
| SA-1707-003 | 3' (0.9m) |
| SA-1707-008 | 8' (2.4m) |
| SA-1707-010 | 10' (3.1m) |
| SA-1707-014 | 14' (4.3m) |
| SA-1707-015 | 15' (4.6m) |
| SA-1707-020 | 20' (6.1m) |
| SA-1707-030 | 30' (9.2m) |
| SA-1707-035 | 35' (10.7m) |
| SA-1707-050 | 50' (15.3m) |

Mini-Gen® Signal Generator

The Mini-Gen® signal generator mounts on the transmissions of buses and trucks to measure road speed or on diesel engines to measure engine speed.



Features:

- Mounts on standard SAE 7/8-18, General Motors, and E1 & E2 DIN 75 532 tachometer outputs
- Non-feed thru models come standard with 1/4" male tab
- Compact, only 1 3/4" in diameter
- Long, reliable life under continuous speeds as high as 4000 RPM
- Usable signal at speeds below 20 RPM (10 Hz)
- Output signal frequency 1/2 of shaft RPM
- Rugged zinc die cast construction
- Heavy duty, two-conductor cable on feed-thru models
- Plated for protection against moisture, salt and dirt
- Environmentally sealed
- Optional connectors available
- Patented design

Signal Generator Output:

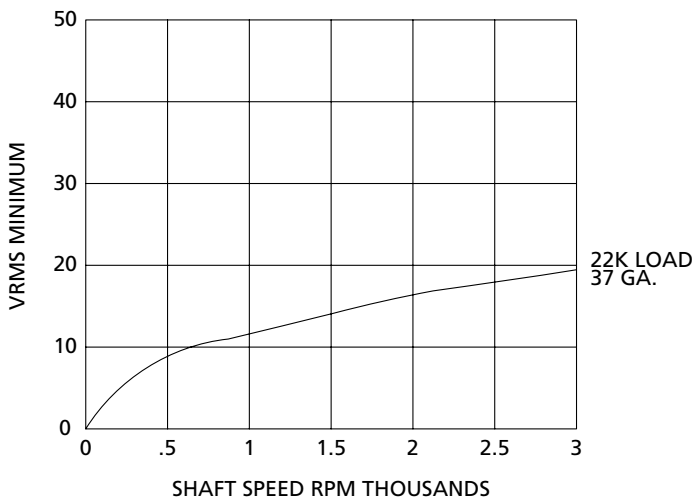

Mini-Gen Timing:

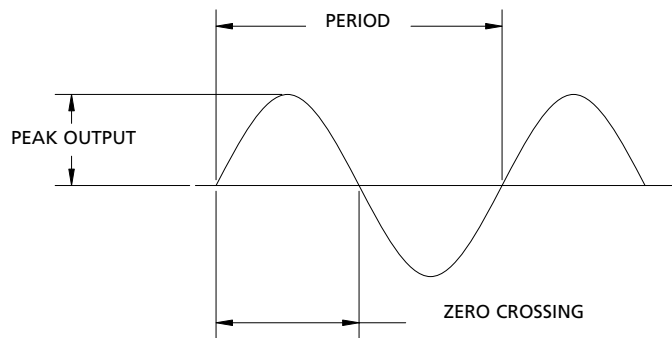

Sinusoidal Output @ 1000 RPM
(Mini-Gen shaft speed) = 500 Hz

1. Voltage output = 25 V peak (RMS = 17.7 volts)
2. Timing between zeroes = 1 millisecond
3. Timing between periods = 2 milliseconds

Timing variation between zero crossing = 7%

Mini-Gen[®] Signal Generator

RUGGED CONSTRUCTION

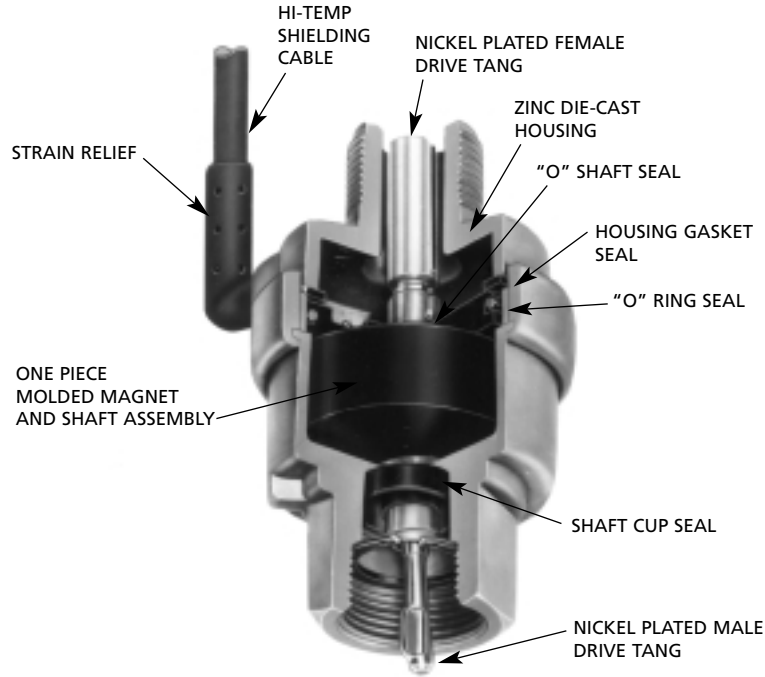

Electrical Specifications:

| | |
|-----------------------------|------------------|
| Output (37 GA) (No Load) | 1750 RPM |
| Minimum | 25 VRMS |
| Maximum | 55 VRMS |
| Resistance (37 GA) | 210 ohms +15% |
| Hi Pot | 600 VDC |
| 60 Pole Magnet | 4000 RPM maximum |

Consult factory for high RPM applications and alternate coil construction for higher output.

Mechanical Specifications:

| | |
|----------------------------|--|
| Operating Temperature | -40°F to + 225°F (-40°C to +107°C) |
| Thread Torque | 15 ft. lbs (20.3 Nm) maximum |
| Lead Pull Test (feed-thru) | 10 lbs (44.5 N) maximum |
| Vibration | 20 G's at 5-2000 Hz |
| Mechanical Shock | Withstands 3 drops to concrete from 3 feet |
| Environmental | Exposure to moisture, salt, fuel oil, lubricants, or transmission fluid will not degrade performance or shorten life |

Mini-Gen[®] Signal Generator

Three Mounting Drives

The Mini-Gen's non-feed thru or feed thru mounting styles permit its use with practically any engine, transmission, tachometer or speedometer manufactured throughout the world.

1. SAE Mounting

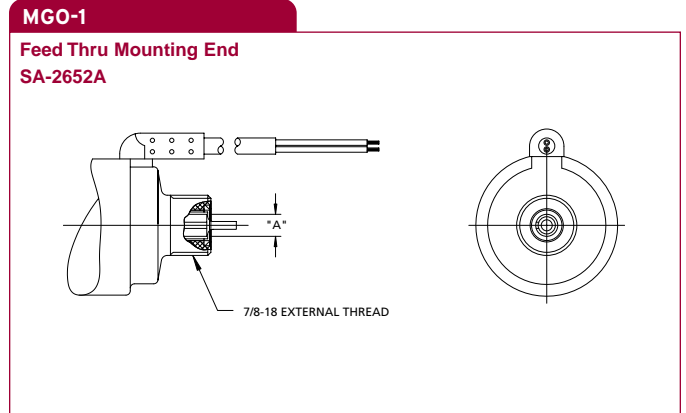
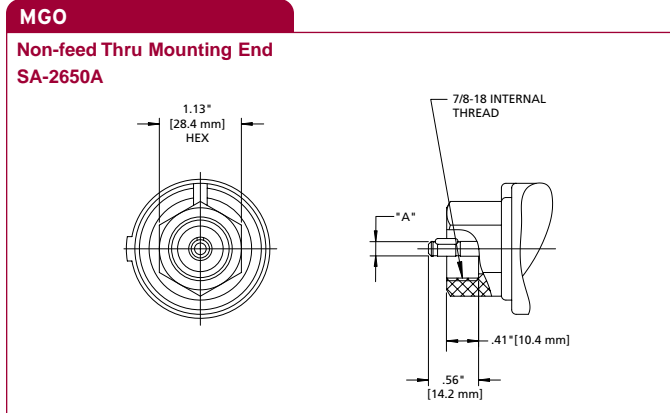

2. General Motors Engine Mounting

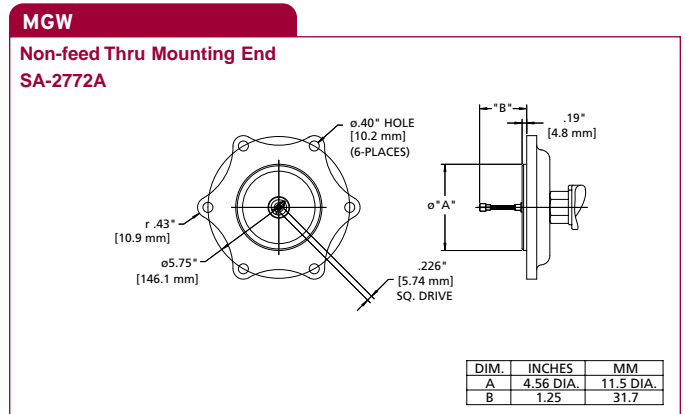
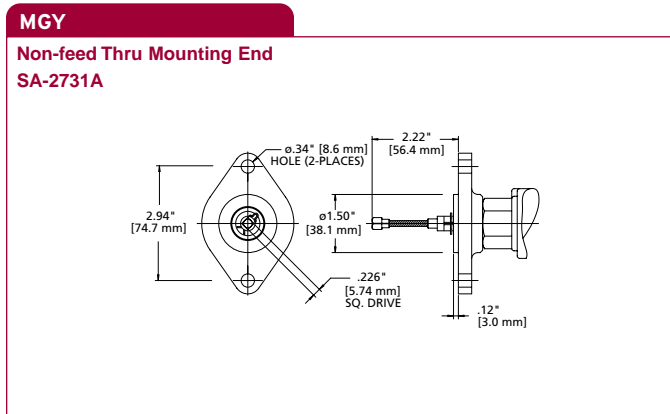

3. Metric Mounting

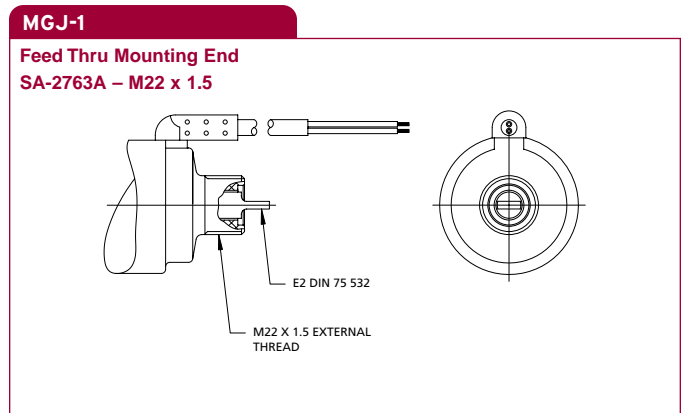
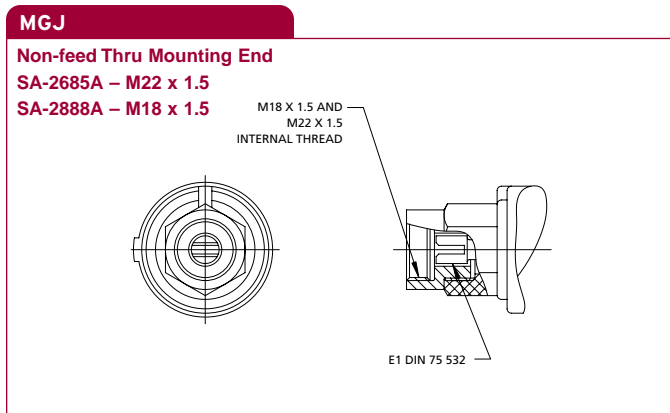

Mini-Gen[®] Signal Generator

Drive Tangs Nickel plated, round or square drive tangs for use with SAE mounting Mini-Gens. To select appropriate drive tang, match Dimension "A" from mounting drive diagram with Part No. from charts below.

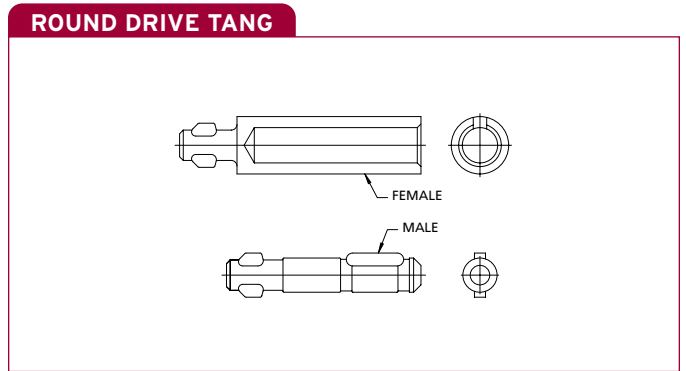
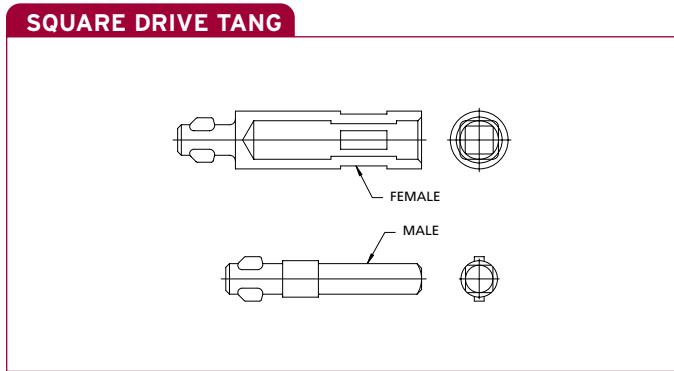

Order Information:

| | Mounting Drive | Drive Designation | Mounting Style |
|-----------------|------------------|-------------------|----------------------------|
| SA-2650A | SAE 7/8-18 | MGO | Non-feed thru |
| SA-2652A | SAE 7/8-18 | MGO-1 | Feed thru |
| SA-2731A | General Motors | MGY | Non-feed thru |
| SA-2772A | General Motors | MGW | Non-feed thru (large ring) |
| SA-2685A | Metric (M22x1.5) | MGJ | Non-feed thru |
| SA-2888A | Metric (M18x1.5) | MGJ | Non-feed thru |
| SA-2763A | Metric (M22x1.5) | MGJ-1 | Feed thru |

Drive Tang Option: For use on SAE mounting drives only (MGO, MGO-1)

Square Drive Tangs

| ORDER NO. Male | ORDER NO. Female | Dimensions "A" (mm) |
|----------------|------------------|---------------------|
| SA-2676 | SA-2635 | .104" (2.64) |
| SA-2633 | SA-2639 | .150" (3.81) |
| SA-2634 | SA-2640 | .193" (4.90) |

Round Drive Tangs

| ORDER NO. Male | ORDER NO. Female | Dimensions "A" (mm) |
|----------------|------------------|-----------------------|
| SA-2677 | SA-2636 | .152" (3.86) |
| SA-2678 | SA-2637 | .187" (4.75) |
| SA-2679 | SA-2638 | .203" (5.16) |
| SA-2672 | | .187" (4.75) Extended |

Metric Drive Tangs

| ORDER NO. | Termination | Specifications |
|----------------|---------------|----------------|
| SA-2962 | Male | E2 DIN 75 532 |
| SA-2961 | Female | E2 DIN 75 532 |

Note: Non-feed thru models come standard with 1/4" male tab.
Lead wire with connector is available as an option.

APECS® Basics

A guide to help in the selection of your electronic engine governing system



Understanding APECS®

The Advanced Proportional Engine Control System (APECS) provides isochronous engine governing through a wide speed range. The system consists of a powerful microprocessor-based controller driving a precision proportional actuator that is connected to the engine's throttle. The APECS controller product line is comprised of the 2000, 3000, 4000, 4500, and 5000 Series models.

Applications

APECS engine governing systems expand speed control functions in diverse applications:

- Power Generation
- Marine
- Construction
- Industrial
- Automotive
- Agriculture/Forestry



Aerial Work Platforms

- Multi-speed control from operator's position

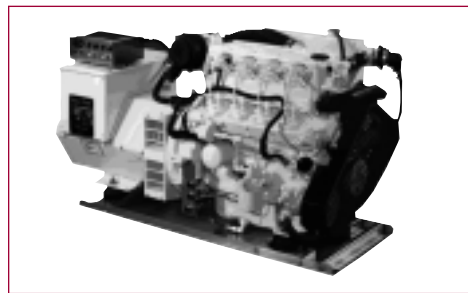

Gensets/Compressors

- Isochronous governing
- Single or two-speed control



Construction Equipment

- Single or multi-speed control
- Design flexibility

APECS® Components and Functions

Understanding APECS®

State-of-the-art APECS digital electronic governor system provides the flexibility to solve the most complex engine control applications. Here's how it works:

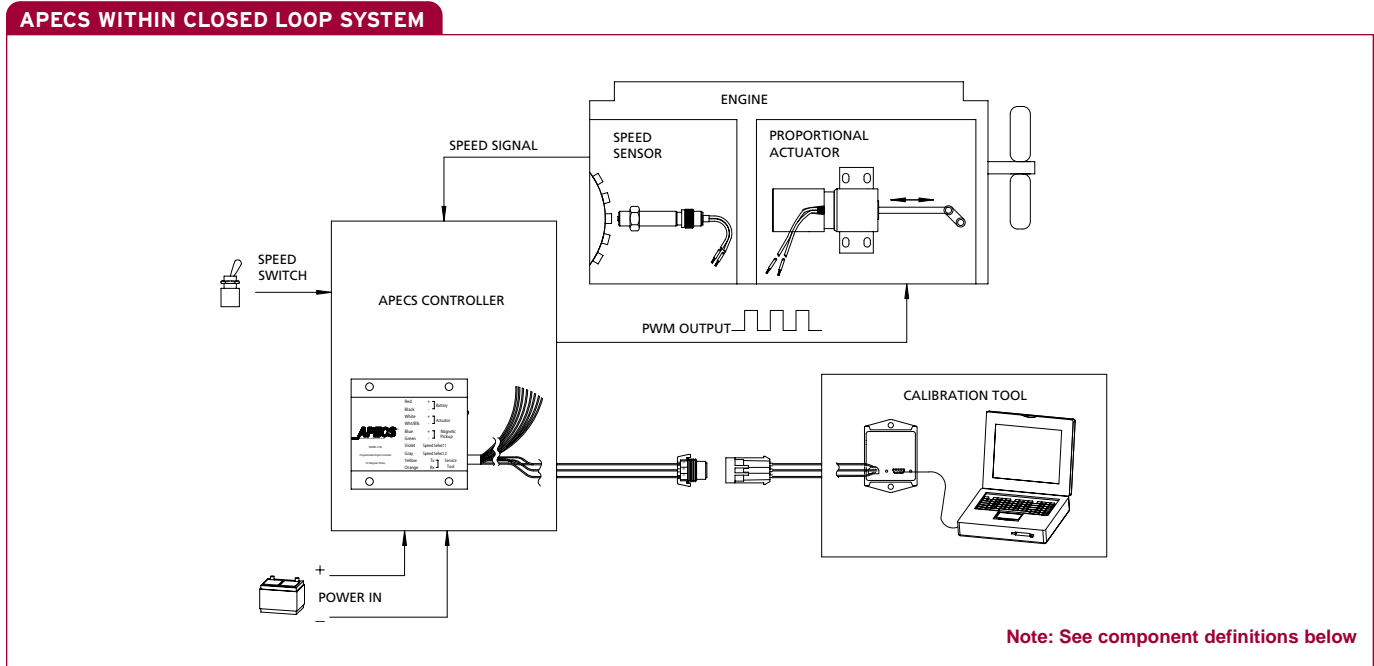

APECS® Components

| | |
|---|--|
| Speed Sensor | The controller processes the speed signal received from the speed sensor, usually a magnetic pickup, and compares it to the desired speed setting. |
| APECS Controller | The powerful microprocessor-based controller is the brain of APECS. |
| Speed Select Switch (optional) | More than one speed can be selected by attaching an external switch (external pot on Series 2000). |
| APECS Calibration Tool (Series 3000, 4000, 4500, & 5000) | The calibration tool is used to configure and adjust your system. It allows interactive, real-time display of engine speed on your computer. |
| Proportional Actuator* | The output of the controller is a pulse width modulated signal to the actuator. The actuator converts the signal to an output shaft position, proportional to the amount of current in the coil. |

*Actuator must be ordered separately. See Linear Proportional Actuators, pages 84-89, for ordering information.

APECS Series Feature Comparison

| | APECS 2000 | APECS 3000 | APECS 4000 |
|--|---|---|--|
| Type of speed control | Isochronous | Isochronous | User selectable isochronous or droop governing |
| Speed signal input options | Magnetic pickup | Magnetic pickup, Hall effect, coil-type ignition, magneto ignition | Magnetic pickup, Hall effect, coil-type ignition, magneto ignition |
| Electrical connections | Screw type | Open lead | Connector |
| External speed command | Analog with external pot | Digital: 2 switch inputs for 4 discrete set speeds or increase/decrease set speed | Analog and Digital: Can select analog (external pot), digital (2 switch inputs) or combination of both |
| Overspeed shutdown, underspeed shutdown | 25% overspeed Shutdown only | All programmable | All programmable |
| Gain setting method | Potentiometer | Computer | Computer with external remote master gain pot |
| Gain adjustments | Proportional, Integral, Derivative, (PID) | PID | PID and Master |
| PC interface | – | On-screen calibration, interactive real time | On-screen calibration, interactive real time |
| Programmable engine speed responses | – | Ramp rates, warm-up time | Ramp rates, warm-up time |
| Drive-by-wire | – | – | Pedal position sensor input with optional idle verification switch input |
| PTO enable switch | – | – | Yes |
| Programmable auxiliary outputs | – | – | Autocrank, crank disable, engine shutdown, remote status lamp, PTO enabled lamp |

APECS Calibration Tool



The calibration tool provides the means of configuring and adjusting your system through software. An interface module connects the controller to your computer.

- Calibration wizard makes set-up easy
- Graphs engine speed on screen, in real time, during calibration
- Last settings are retained in controller, even after shutdown

Please see Controllers, pages 74-83, (APECS 3000, 4000, 4500, & 5000) for ordering information.

Magnetic Pickups

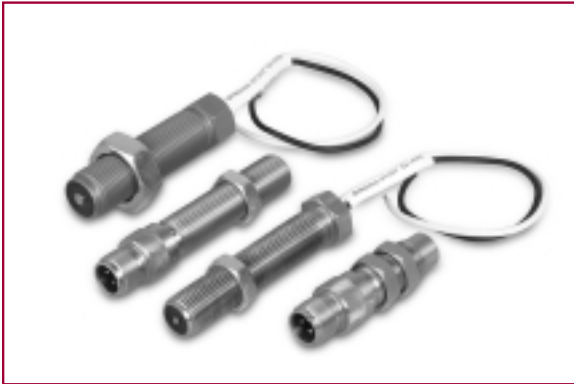

Magnetic pickup speed sensor converts mechanical motion to an AC voltage without external power. It transmits a signal each time a gear tooth passes near the center pole piece.

- 5/8 and 3/4 UNF sizes
- Endures shock and vibration and extreme temperature range
- Choice of wire leads or sealed connector

Please see Speed Sensors, pages 64-69, for ordering information.

Linkage and Mounting Hardware



Linkage connects the actuator shaft to the engine control lever. A good linkage contributes to accurate, stable, and responsive performance with minimal play and friction.

- Allows for minor misalignments
- Minimal friction, binding and backlash
- Hardware for longer and shorter linkages

Please see Actuator Accessories, pages 100-101, for ordering information.



WARNING: An overspeed shutdown device, independent of the APECS system, should be provided to prevent loss of engine control that may cause personal injury or equipment damage.

APECS® 2000

The powerful microprocessor-based controller of the APECS (Advanced Proportional Engine Control System) monitors the actual speed of the engine through a speed sensor, compares the actual speed with the desired speed, then sends a pulse width modulated signal to the precision proportional actuator to maintain the desired speed.



Features:

- Proportional, Integral and Derivative control (PID)
- Isochronous governing $\pm 0.25\%$ (20 turn setpoint)
- Remote speed setpoint ($\pm 10\%$ speed change or 0-100% of internal setpoint)
- Surface mount technology
- Signal source: magnetic pickup
- Electrostatic discharge protection
- Reverse polarity protection
- Protection against miswiring
- Diagnostics for broken wire, overspeed, and internal component check
- Engine compartment mountable and can be used with all sizes of APECS actuators
- Rugged case potted for environmental protection

Order Information:

| ORDER NO. | Model |
|----------------|-------|
| SA-4389 | 2000 |

E.E.C. Directive Compliance: All parts supplied by Woodward are classified as components, and therefore are not "CE" marked. Please contact factory direct for details on specific product compliance with 89/336/EEC and 89/392/EEC directives.

Dimensions:

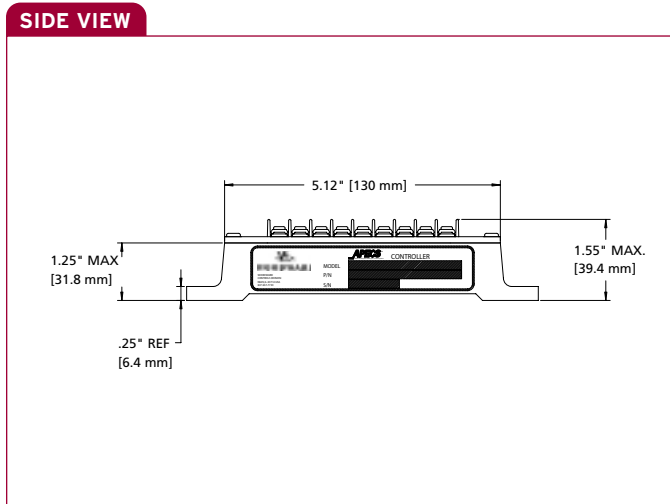
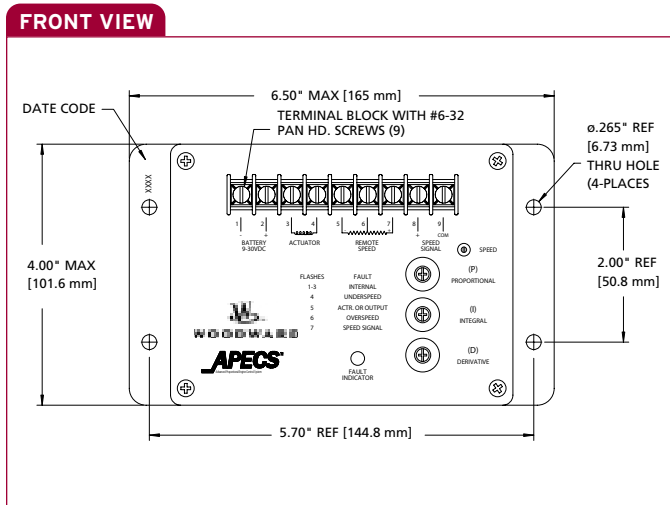

Electrical Specifications:

| | |
|----------------------|--|
| Operating Voltage | 9-30 VDC (wide range) |
| Overspeed Protection | Automatic shutdown at 125% of setpoint speed |
| Speed Input Signal | 250 Hz to 10,000 Hz (5 ranges) |
| Signal Input Minimum | 2 VRMS at cranking |
| Output | PWM up to 8 A |

Mechanical Specifications:

| | |
|-----------------------|--|
| Operating Temperature | -40°F to 185°F (-40°C to 85°C) |
| Vibration | 6 G's from 20 to 500 Hz |
| Shock | 4 foot drop test |
| Protection | Potted electronics for environmental protection |
| Terminals | Nickel plated, humidity and salt spray resistant |
| Weight | 1.4 lbs (0.6 kg) |

Specifications are for reference only.



WARNING: An overspeed shutdown device, independent of the APECS system, should be provided to prevent loss of engine control that may cause personal injury or equipment damage.

APECS® 3000

APECS (Advanced Proportional Engine Control System) governs engine speed and is computer calibrated using all-digital electronic technology.



Features:

- Isochronous engine control
- All-digital electronic technology
- Calibrations set with a personal computer
- Easy to calibrate with APECS start-up wizard
- Calibration tool graphs engine speed on screen, in real time, during calibration process
- All settings remain in memory during shutdown
- Remote speed control available with external switches:
 - Preprogram up to four discrete speeds and set ramp rates between speeds, or
 - Manually increase/decrease engine speed at preset rates
- Compatible with all Woodward proportional actuators
- Operates on both 12 volt and 24 volt systems

Order Information:

APECS 3000

| ORDER NO. | Model | Speed Signal Input | External Switch Connection |
|----------------|-------|--------------------|--------------------------------------|
| SA-4450 | 3100 | Magnetic Pickup | Switch Activated to Battery Positive |
| SA-4451 | 3100 | Magnetic Pickup | Switch Activated to Ground |
| SA-4452 | 3200 | Spark Ignition | Switch Activated to Ground |
| SA-4453 | 3300 | Magneto Ignition | Switch Activated to Ground |
| SA-4471 | 3400 | Hall Effect Sensor | Switch Activated to Ground |

APECS Calibration Tool

| ORDER NO. | Model | Description |
|----------------|-------|--|
| SA-4455 | ACT | For all Series 3000 controllers, includes interface module, program diskette, RS-232 cable, and User's Manual. (Computer not included) |

E.E.C. Directive Compliance: All parts supplied by Woodward are classified as components, and therefore are not "CE" marked. Please contact factory direct for details on specific product compliance with 89/336/EEC and 89/392/EEC directives.

APECS® 3000

Dimensions:

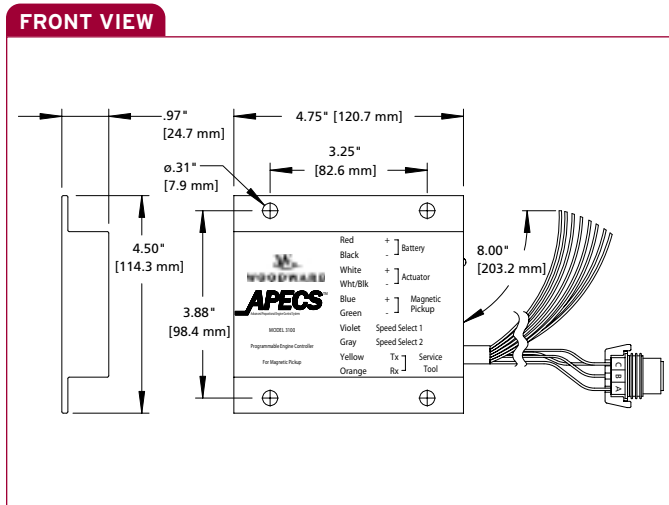

Electrical Specifications:

| | |
|----------------------------|--|
| Supply Voltage | 9-30 VDC, negative ground. Reverse polarity protected |
| Magnetic Pickup | 2 VRMS minimum (during cranking) required signal |
| Switch Inputs | Two switch inputs, pre-programmable to select up to four speeds Switch activated to ground or to battery positive must be specified |
| Output to Actuator | Pulse width modulated, 8 A maximum |
| Calibration Tool Interface | Requires interface adapter and DOS based software for initial calibration setup |

Mechanical Specifications:

| | |
|----------------------------|--|
| Connections | Sealed connector to interface module All other electrical connections are open lead |
| Operating Temperature | -40°F to +185°F (40°C to +85°C) |
| Vibration | 6 G's from 40 to 2000 Hz |
| Electronic Interface (EMI) | 10 V/m 27-1000 MHz |
| Shock | 20 G's peak @ 35 Hz |
| Mounting | 4 holes |
| Weight | 1.18 lb (0.54 kg) |
| Drop Test | 1 m on concrete surface |

APECS® Controllers

Specifications are for reference only.



WARNING: An overspeed shutdown device, independent of the APECS system, should be provided to prevent loss of engine control that may cause personal injury or equipment damage.

APECS® 4000

APECS 4000 expands Woodward's line of programmable engine governors to address the needs of the stationary and mobile equipment industry. Enhanced input and output capability, combined with a flexible configuration, permits APECS 4000 to easily adapt to a wide variety of engine governing applications.



Features:

- User selectable isochronous or droop governing
- Analog input suitable for many uses:
 - Pedal position sensor with idle verification switch
 - Remote speed adjustments
 - Trim potentiometer
- Two switched inputs allow user to:
 - Program up to four discrete speeds and set ramp rates between speeds, or
 - Manually increase or decrease speed at preset rates with variable speed control
- PTO enable switch to select between pedal input and speed switches in mobile applications
- User selectable engine protection switch input (high coolant temperature, low oil pressure)
- Compatible with Woodward proportional actuators
- Auxiliary output configurable in several ways:
 - Engine shutdown
 - Crank disable
 - Remote status lamp
 - Autocrank
 - PTO enabled lamp
- User-friendly calibration tool:
 - Programmable PID gains
 - Programmable speed setpoints, ramp rates
 - Easy to calibrate using APECS start-up wizard
 - Graphical or numerical real time display
- Current protection limits current to the actuator to protect from overheating
- Status lamp (LED) signals normal engine running condition and diagnostics including overspeed and underspeed
- Sealed, tamper-resistant enclosure, chemical resistant to most automotive oils and liquids

Order Information:

APECS 4000

| ORDER NO. | Model | Speed Signal Input | External Switch Connection |
|-----------|-------|--------------------|--------------------------------------|
| SA-4467 | 4100 | Magnetic Pickup | Switch Activated to Battery Positive |
| SA-4468 | 4200 | Spark Ignition | Switch Activated to Battery Positive |
| SA-4469 | 4300 | Magneto Ignition | Switch Activated to Battery Positive |
| SA-4470 | 4400 | Hall Effect Sensor | Switch Activated to Battery Positive |

APECS Calibration Tool

| ORDER NO. | Model | Description |
|-----------|----------------|--|
| SA-4475 | ACT Kit | For all Series 4000 controllers, includes interface module, program diskette, RS-232 cable, and User's Manual. (Computer not included) |
| SA-4473 | Connector Kit* | For all controllers |

*Connector kit contains Molex mating connector shell and terminals.

E.E.C. Directive Compliance: All parts supplied by Woodward are classified as components, and therefore are not "CE" marked. Please contact factory direct for details on specific product compliance with 89/336/EEC and 89/392/EEC directives.

APECS® 4000

Dimensions:

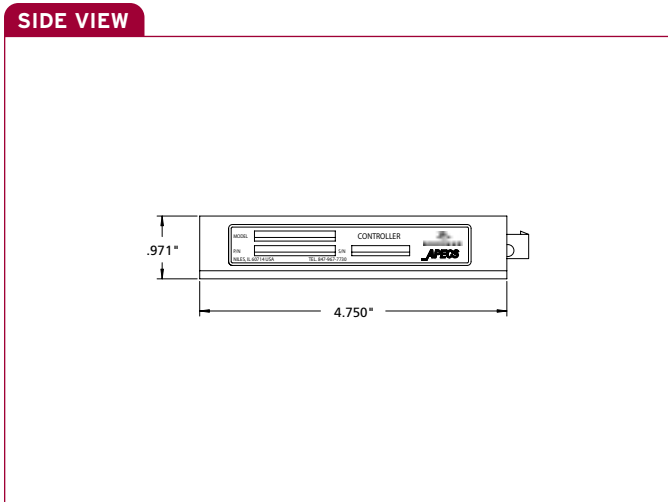
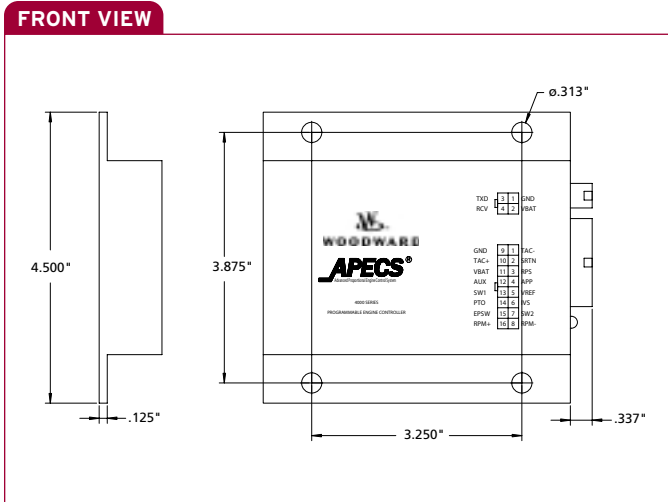

Typical Applications

- Power Generation
- Automotive
- Marine
- Construction
- Industrial
- Agriculture/Forestry

Electrical Specifications:

| | |
|---------------------------------|---|
| Supply Voltage | 9-30 VDC, negative ground. Reverse polarity protected |
| Switch Inputs | Two switch inputs, pre-programmable to select up to four speeds PTO switch Engine protection switch |
| Speed Sensing | Magnetic pickup input, Ignition input, Magneto input, Hall effect sensor |
| Shock | 20 G's peak @ 45 Hz |
| Vibration | 6 G's from 40-2000 Hz |
| Electromagnetic Interface (EMI) | 30V/m 20-1000M Hz |

Mechanical Specifications:

| | |
|-----------------------|---|
| Connector | Molex part no. 39-30-1160 Mates with Molex part no. 39-01-2160 (not supplied with controller) Terminals required 16 AWG part no. 39-00-0078 18-24 AWG part no. 39-00-0039 |
| External Analog Input | Trim, set speed with pot and drive-by-wire with IVS option |
| Output to Actuator | Pulse width modulated 8 A maximum |
| Temperature | -40°F to 185°F (-40°C to 85°C) |
| Weight | 1.18 lb (0.54 kg) |
| Calibration | Requires interface adapter and software for calibration setup |

APECS® Controllers

Specifications are for reference only.



WARNING: An overspeed shutdown device, independent of the APECS system, should be provided to prevent loss of engine control that may cause personal injury or equipment damage.

NEW

APECS® 4500

The APECS 4500 electronic controller provides maximum control and optimal engine performance. By adjusting the fuel control lever with a Woodward proportional actuator the 4500 system controls and limits engine speed. By adjusting to load, temperature and fuel quality it optimizes your engine's operating efficiency.



Features:

- Control capabilities include engine/ ground speed control, rate of acceleration control, drive-by-wire operation, variable speed operation, and power take-off operation.
- Two user-selectable auxiliary outputs can be configured for glow plug control, autocrank control, engine shutdown, remote diagnosis, and mode lamp.
- Calibration is simple using ACT, Woodward's proprietary software. The controller can be calibrated on any IBM-compatible PC, allowing for easy customization and re-programmability.
- Universal speed input permits use with magnetic pickups, coil-type spark ignition systems, magneto spark ignition systems, and Hall Effect sensors.
- Internal diagnostics monitor engine operation and the status LED indicates malfunctions through coded flashing. Built-in engine protection capability can monitor engine coolant and oil pressure.
- Sealed, waterproof connectors assure reliability in harsh environments.

Order Information:

| | |
|----------------|--|
| SA-4489 | APECS 4500 Controller |
| SA-4490 | Deutsch Connector Kit |
| SA-4488 | ACT Kit (All-purpose Calibration Tool) |

Dimensions:

APECS 4500 has two 12-pin Deutsch connectors labeled J1 (grey) and J2 (black). Deutsch part numbers are DTM06-12SA (J1 grey) and DTM06-12SB (J2 black).

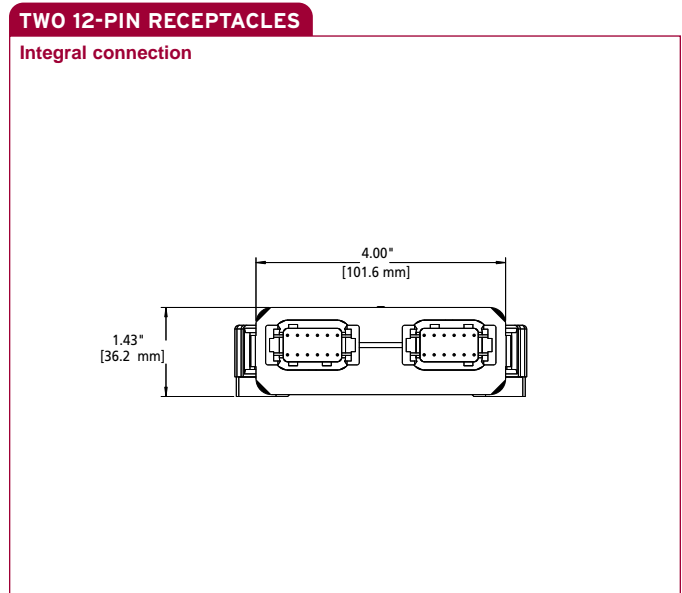
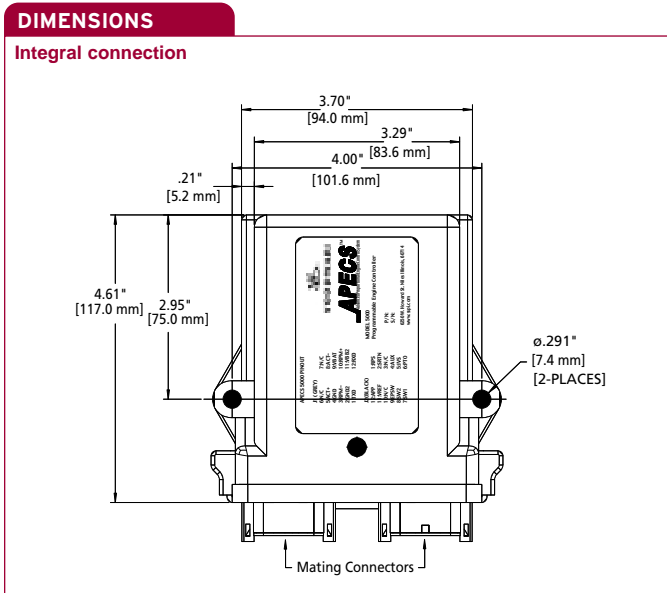

Programmable Features:

- Analog speed setpoint input is suitable for use with a potentiometer or an accelerator pedal position sensor (idle verification available).
- Actuator current protection protects actuator from burning out.
- Autocrank permits remote operation of engines.
- Two auxiliary outputs drive a lamp or relay.
- Glow plug control
- Droop governing allows non-isochronous speed governing.
- Engine protection input protects against adverse conditions such as loss of engine oil pressure or excessive coolant temperature.
- Engine start calibration expedites special startup operations such as warm-up speed, reduced governor gains, missing speed signal
- Overspeed/underspeed protection
- PID gain adjustment allows governor response to be adjusted by user.
- PTO switch input permits selection between analog speed setpoint input and switched speed setpoint inputs in mobile applications.
- Switched speed setpoint inputs allow multiple speed settings using switches. This feature can be configured together with the analog input (speed pot) for a variety of speed select options.

Specifications:

| | |
|-----------------------|---|
| Power Input | 9-32 VDC, reverse polarity protected |
| EMI Immunity | (ISO 14982:1998/E) 30 V/M 20 MHz to 1000 MHz |
| Output to Actuator | Pulse width modulated, 6 amps max. |
| Auxiliary Outputs | 200 mA maximum (sinking) |
| Operating Temperature | -40° F to +185° F (-40° C to +85° C) |
| Vibration | 6 G's from 40 Hz to 2000 Hz |
| Calibration | Requires interface adapter and software for calibration |
| Enclosure | Deutsch PCB enclosure EEC-325X4 with two 12-pin receptacles |
| Weight | Approx. 0.6 lb (0.27 kg) |

NEW

APECS® 5000

This newest addition to the APECS series of programmable engine controllers applies Woodward's advanced digital governing technology to stepper motors. Designed as an economical means of throttle actuation in small spark ignition engines, the APECS 5000 is also an excellent engine protection system.



Features:

- User-selectable isochronous or droop governing
- Actuator output tailored to Woodward bi-polar stepper motor. Position control to one-quarter degree accuracy
- Easily programmed with software calibration tool:
 - Adjustable PID gains
 - Programmed speed setpoints, ramp rates
 - Simplified calibration with software wizard
 - Graphic or numeric real-time display
- Universal speed input for either magnetic pickup, coil-type spark ignition system, magneto spark ignition system, or Hall Effect sensor.
- External analog speed setpoint input may be configured for trim mode or full authority mode.
- Two switched inputs allow for either multi-speed or variable speed operation.
- PTO switch input enables selection between analog and speed setpoint switch inputs. Also used to initiate an autocrank sequence when auxiliary output is configured for this purpose.
- Idle verification switch input can detect pedal position sensor faults.
- Engine protection switch input connects to one or more user-selected engine protection switches (e.g. engine coolant, engine oil pressure).
- Status lamp (LED) signals normal engine running condition and diagnostics including overspeed and underspeed.
- Auxiliary output configurable in several ways:
 - Engine shutdown
 - Crank disable
 - Autocrank sequence
 - Remote fault lamp or remote status lamp
- Ideal for mobile or stationary applications.

Order Information:

| | |
|----------------|--|
| SA-4486 | APECS 5000 Controller |
| SA-4490 | Deutsch Connector Kit |
| SA-4488 | ACT Kit (All-purpose Calibration Tool) |

E.E.C. Directive Compliance: All parts supplied by Woodward are classified as components, and therefore are not "CE" marked. Please contact factory direct for details on specific product compliance with 89/336/EEC and 89/392/EEC directives.

APECS® 5000

Electrical Specifications:

| | | |
|---------------------------------|--------------------------------------|----------------|
| Power Input | 9-32 VDC, reverse polarity protected | |
| EMI Immunity (ISO 14982:1988/E) | 30 V/M 20 MHz to 1000 MHz | |
| Operating Current | <u>12 Volt</u> | <u>24 Volt</u> |
| Operating: | 1.25 A | 1.25 A |
| Standby: | 25 mA | 25 mA |
| Auxiliary Outputs | 200 mA maximum | |

Mechanical Specifications:

| | |
|-----------------------|---|
| Operating Temperature | -40°F to +185°F (-40°C to +85°C) |
| Vibration | 6 G's from 40 to 2000 Hz |
| Calibration | Requires interface adapter and software for calibration setup |
| Enclosure | Deutsch PCB enclosure EEC-325X4 with two 12-pin receptacles |
| Weight | Approx. 0.6 lbs (0.27 kg) |

APECS® Controllers

DIMENSIONS

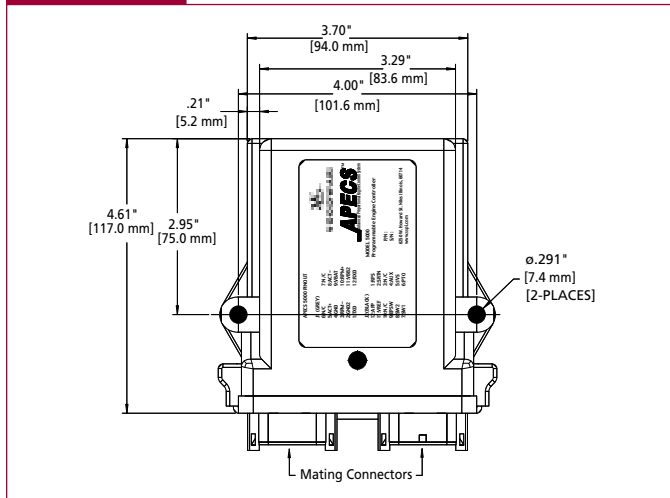

TWO 12-PIN RECEPTACLES

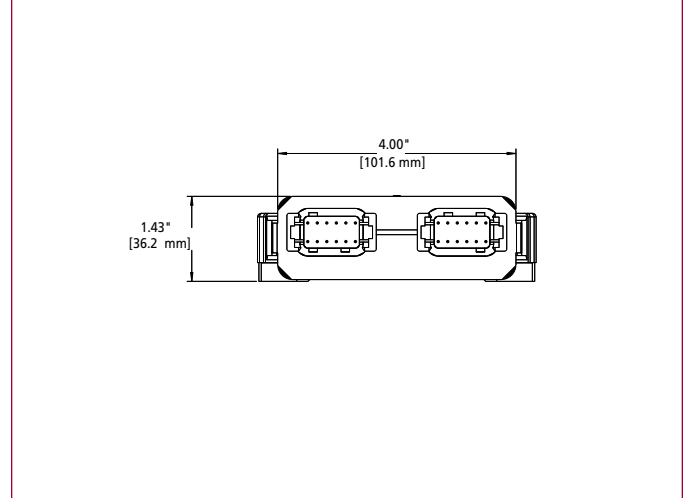

Specifications and dimensions are for reference only.

APECS® 0175 Series Actuators

Provides proportional fuel control for construction, industrial and agricultural equipment. 1.75" diameter spring-return actuator, pull or push models, three spring types available.



Features:

- Pull or push actuation (Model 0175 pull, Model 0175P push)
- Flange or base mount
- Failsafe operation using spring to return actuator to minimum fuel position
- Corrosion resistant, plated steel housing and mounting base/flange
- Precise engine speed control when used with APECS electronic controllers. (See Controllers section, pages 74-83, for ordering information.)
- Variety of mounting styles, plungers, terminations, and springs available

Order Information: Complete the following model descriptions to build your Order No.

| | | | | | |
|----------------------|---------------------|--------------------|------------------------------|-----------------------|----------------|
| () | - | () | () | () | () |
| Model No. | Voltage | Mounting Style | Plunger Type | Termination Type | Return Spring* |
| 0175 Pull | 12 12 VDC | A Flange | 2 Ext. ¼-28 thread | L Lead wire | S1 |
| 0175P Push | 24 24 VDC | E Base | 3 Ext. M-6 thread | C Connector | S2 |
| | | | | | S3 |

*Spring Chart

| Spring Type | PART NO. | De-energized Spring Force | Energized Spring Force | Spring Rate |
|-------------|----------|---------------------------|------------------------|--------------------------|
| S1 | SA-4703 | 0.50 lbs (2.2 N) | 5.25 lbs (23.4 N) | 5.94 lbs/in (0.16 kg/mm) |
| S2 | SA-4704 | 0.25 lbs (1.1 N) | 6.00 lbs (26.7 N) | 7.20 lbs/in (0.13 kg/mm) |
| S3 | SA-4472 | 0.40 lbs (1.8 N) | 1.60 lbs (7.1 N) | 1.53 lbs/in (0.03 kg/mm) |

0175 / Pull Actuation

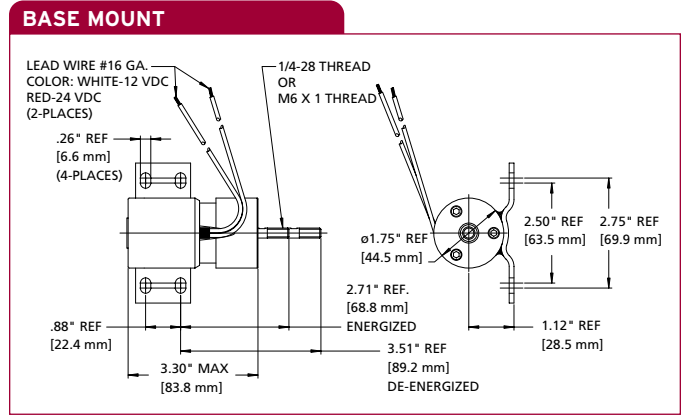
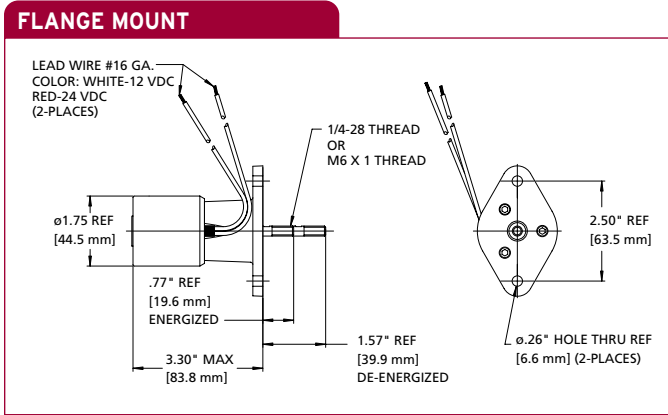

0175P / Push Actuation

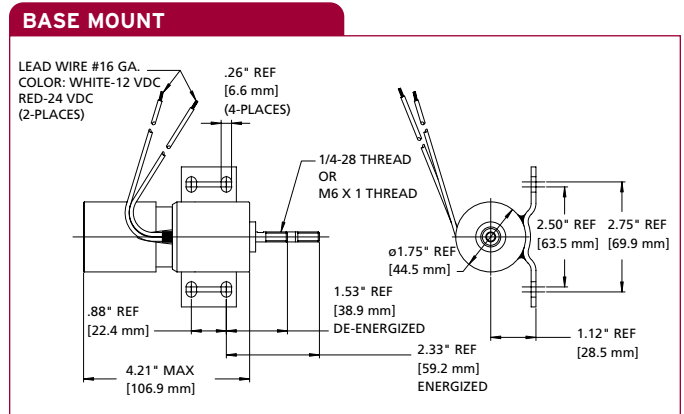
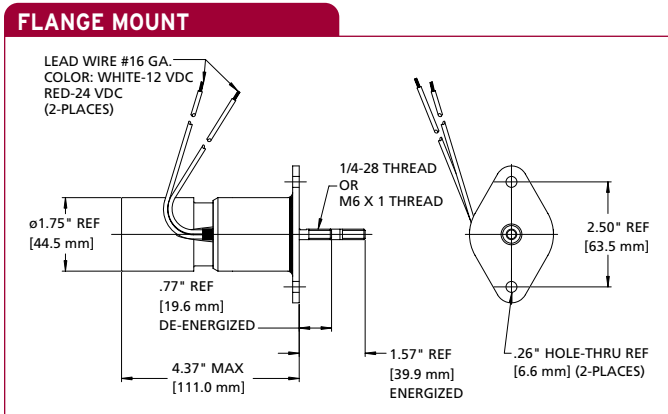

Electrical Specifications:

| | |
|-----------------------|---|
| Stroke | 0.8" Maximum (20.3 mm) |
| Net Force | 4.0 lbs (17.8 N) |
| Work Rating | 0.3 ft. lbs (0.41 Nm) |
| Nominal Rated Current | 4.3 A (12 VDC) 2.3 A (24 VDC) |
| Response Time | 30 milliseconds for 10%-90% of stroke |
| Resistance* (nominal) | 2.80 Ohms (12 Volt) 10.63 Ohms (24 Volt) |

Mechanical Specifications:

| | |
|-----------------------|--|
| Operating Temperature | -40 °F to + 250 °F (-40 °C to + 121 °C) |
| Vibration | 15 G's |
| Shock | 200 G's |
| Weight | Approx. 1.5 lbs (0.7 kg) |

Specifications are for reference only.

*At ambient temperature



WARNING: An overspeed shutdown device, independent of the APECS system, should be provided to prevent loss of engine control that may cause personal injury or equipment damage.

APECS® 0250 Series Actuators

Provides proportional fuel control for construction, industrial and agricultural equipment. 2.50" diameter spring-return actuator, pull or push models, four spring types available.



Features:

- Pull or push actuation (Model 0250 pull, Model 0250P push)
- Flange or base mount
- Failsafe operation using spring to return actuator to minimum fuel position
- Corrosion resistant, plated steel housing and mounting base/flange
- Precise engine speed control when used with APECS electronic controllers. (See Controllers section, pages 74-83, for ordering information.)
- Variety of mounting styles, plungers, terminations, and springs available

Order Information: Complete the following model descriptions to build your Order No.

| () | () | () | () | () | () |
|----------------------|---------------------|--------------------|------------------------------|-----------------------|----------------|
| Model No. | Voltage | Mounting Style | Plunger Type | Termination Type | Return Spring* |
| 0250 Pull | 12 12 VDC | A Flange | 2 Ext. ¼-28 thread | L Lead wire | S1 |
| 0250P Push | 24 24 VDC | E Base | 3 Ext. M-6 thread | C Connector | S2 |
| | | | | | S3 |
| | | | | | S4 |

*Spring Chart

| Spring Type | PART NO. | De-energized Spring Force | Energized Spring Force | Spring Rate |
|-------------|----------|---------------------------|------------------------|---------------------------|
| S1 | SA-4684 | 1.60 lbs (7.1 N) | 11.40 lbs (50.7 N) | 9.80 lbs/in (0.17 kg/mm) |
| S2 | SA-4685 | 0.75 lbs (3.3 N) | 14.00 lbs (62.3 N) | 13.25 lbs/in (0.24 kg/mm) |
| S3 | SA-4728 | 0.75 lbs (3.3 N) | 8.80 lbs (39.1 N) | 8.05 lbs/in (0.14 kg/mm) |
| S4 | SA-4729 | 0.75 lbs (3.3 N) | 14.55 lbs (64.7 N) | 13.80 lbs/in (0.25 kg/mm) |

0250 / Pull Actuation

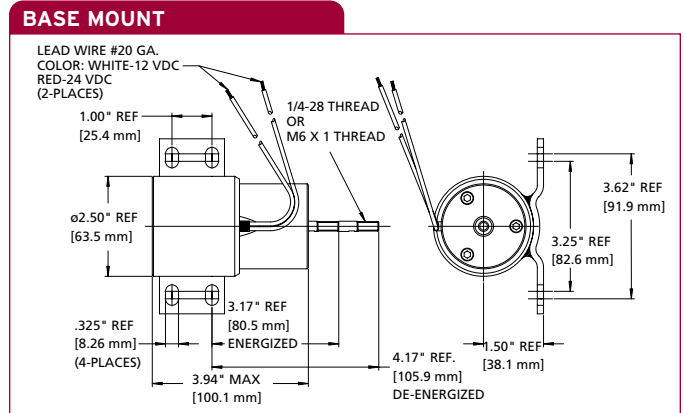
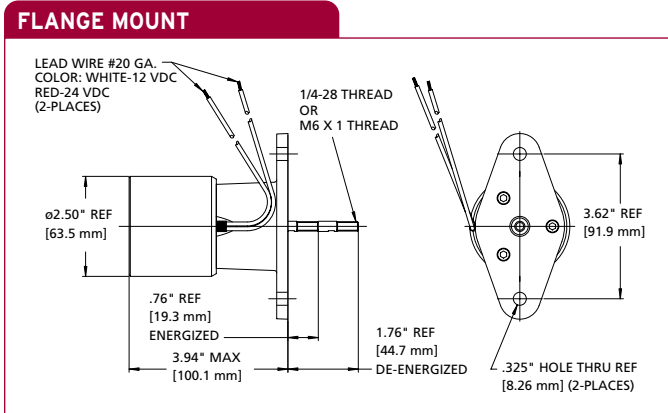

0250P / Push Actuation

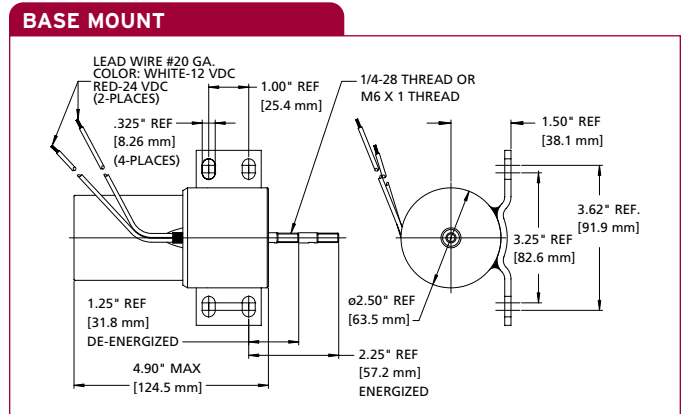
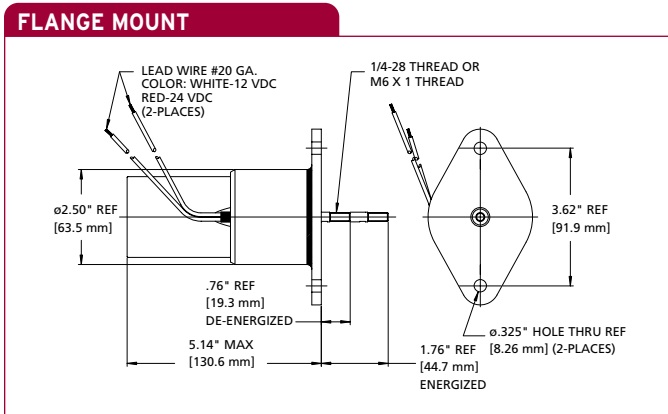

Electrical Specifications:

| | |
|-----------------------|--|
| Stroke | 1.0" Maximum (25.4 mm) |
| Net Force | 6.0 lbs (26.7 N) |
| Work Rating | 0.7 ft. lbs (0.95 Nm) |
| Nominal Rated Current | 6.8 A (12 VDC) 3.5 A (24 VDC) |
| Response Time | 65 milliseconds for 10%-90% of stroke |
| Resistance* (nominal) | 1.76 Ohms (12 Volt) 6.84 Ohms (24 Volt) |

Mechanical Specifications:

| | |
|-----------------------|--|
| Operating Temperature | -40 °F to + 250 °F (-40 °C to + 121 °C) |
| Vibration | 15 G's |
| Shock | 200 G's |
| Weight | Approx. 3.0 lbs (1.4 kg) |

Specifications are for reference only.

*At ambient temperature



WARNING: An overspeed shutdown device, independent of the APECS system, should be provided to prevent loss of engine control that may cause personal injury or equipment damage.

APECS® 0300 Series Actuators

Provides proportional fuel control for construction, industrial and agricultural equipment. 3.00" diameter spring-return actuator, pull or push models, three spring types available.



Features:

- Pull or push actuation (Model 0300 pull, Model 0300P push)
- Flange or base mount
- Failsafe operation using spring to return actuator to minimum fuel position
- Corrosion resistant, plated steel housing and mounting base/flange
- Precise engine speed control when used with APECS electronic controllers. (See Controllers section, pages 74-83, for ordering information.)
- Variety of mounting styles, plungers, terminations, and springs available

Order Information: Complete the following model descriptions to build your Order No.

| () | () | () | () | () | () |
|----------------------|---------------------|--------------------|------------------------------|-----------------------|----------------|
| Model No. | Voltage | Mounting Style | Plunger Type | Termination Type | Return Spring* |
| 0300 Pull | 12 12 VDC | A Flange | 2 Ext. ¼-28 thread | L Lead wire | S1 |
| 0300P Push | 24 24 VDC | E Base | 3 Ext. M-6 thread | C Connector | S2 |
| | | | | | S3 |

*Spring Chart

| Spring Type | PART NO. | De-energized Spring Force | Energized Spring Force | Spring Rate |
|-------------|----------|---------------------------|------------------------|---------------------------|
| S1 | SA-4713 | 4.25 lbs (18.9 N) | 19.50 lbs (86.7 N) | 15.25 lbs/in (0.27 kg/mm) |
| S2 | SA-4714 | 1.00 lbs (4.4 N) | 22.00 lbs (97.9 N) | 21.00 lbs/in (0.37 kg/mm) |
| S3 | SA-4829 | 2.13 lbs (9.5 N) | 9.75 lbs (43.4 N) | 7.62 lbs/in (0.14 kg/mm) |

0300 / Pull Actuation

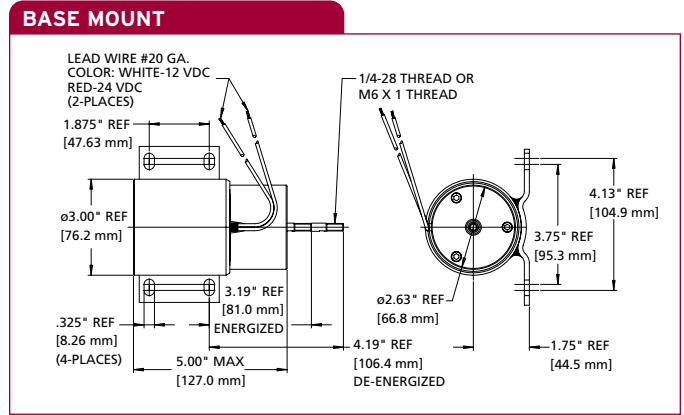
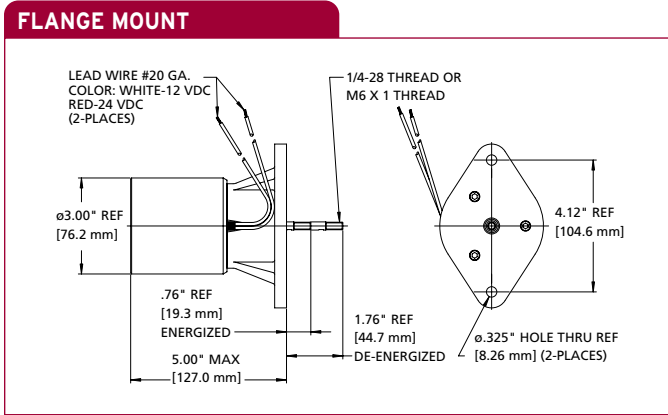

0300P / Push Actuation

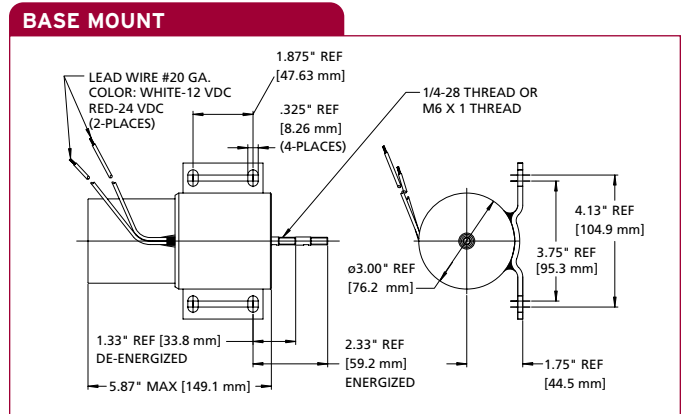
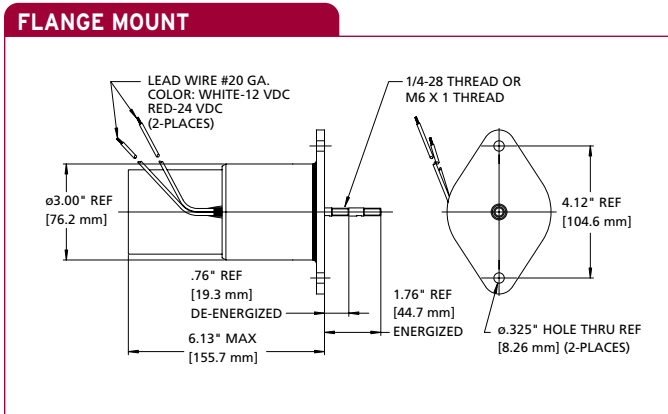

Electrical Specifications:

| | |
|-----------------------|--|
| Stroke | 1.0" Maximum (25.5 mm) |
| Net Force | 15.0 lbs (66.7 N) |
| Work Rating | 1.3 ft. lbs (1.76 Nm) |
| Nominal Rated Current | 6.9 A (12 VDC) 3.6 A (24 VDC) |
| Response Time | 80 milliseconds for 10%-90% of stroke |
| Resistance* (nominal) | 1.72 Ohms (12 Volt) 6.57 Ohms (24 Volt) |

Mechanical Specifications:

| | |
|-----------------------|-----------------------------------|
| Operating Temperature | -40°F to +250°F (-40°C to +121°C) |
| Vibration | 15 G's |
| Shock | 200 G's |
| Weight | Approx. 6.5 lbs (3.0 kg) |

Specifications are for reference only.

*At ambient temperature



WARNING: An overspeed shutdown device, independent of the APECS system, should be provided to prevent loss of engine control that may cause personal injury or equipment damage.

Linkage Free Integral-Type

Actuators provide proportional fuel control for construction, industrial, and agricultural equipment. For direct mounting to specific engines.



Features:

- Direct replacement for integral mount fuel shutoff solenoid
- Fuel pump shutoff force built into actuator
- Responds in milliseconds to changes in current from a pulse width modulated signal generated by the controller
- Precise engine speed control when used with APECS electronic controllers (See Controllers section, pages 74-83, for ordering information)
- Simple installation, no brackets or linkages necessary

Available for:

- Kubota Super 5 Series
- Kubota 3300 Series
- Mitsubishi SL Series
- Perkins 700 Series
- Yanmar TNE Series
- Yanmar 2V78 Series

Order Information:

| ORDER NO. | Engine Series | Model | Voltage |
|--------------------|----------------|-------------------------|---------|
| SA-4573-12 | Kubota Super 5 | 0175-12 A5LS Kubota | 12 VDC |
| SA-4573-24 | Kubota Super 5 | 0175-24 A5LS Kubota | 24 VDC |
| SA-4828-12 | Kubota 3300 | 0175-12 A6LS Kubota | 12 VDC |
| SA-4828-24 | Kubota 3300 | 0175-24 A6LS Kubota | 24 VDC |
| SA-4837-12* | Mitsubishi SL | 0175-12 B7LS Mitsubishi | 12 VDC |
| SA-4837-24* | Mitsubishi SL | 0175-24 B7LS Mitsubishi | 24 VDC |
| SA-4777-12 | Perkins 700 | 0175-12 A6LS Perkins | 12 VDC |
| SA-4777-24 | Perkins 700 | 0175-24 A6LS Perkins | 24 VDC |
| SA-4574-12 | Yanmar TNE | 0175-12 S5LS Yanmar | 12 VDC |
| SA-4574-24 | Yanmar TNE | 0175-24 S5LS Yanmar | 24 VDC |
| SA-4848-12 | Yanmar 2V78 | 0175-12 S6LS Yanmar | 12 VDC |
| SA-4848-24 | Yanmar 2V78 | 0175-24 S6LS Yanmar | 24 VDC |

*Threaded-mount unit, locknut supplied

E.E.C. Directive Compliance: All parts supplied by Woodward are classified as components, and therefore are not "CE" marked. Please contact factory direct for details on specific product compliance with 89/336/EEC and 89/392/EEC directives.

Linkage Free Integral-Type

Electrical Specifications:

| | |
|---------------|----------------------------------|
| Rated Voltage | 12 or 24 VDC |
| Rated Current | 4.3 A (12 VDC) 2.3 A (24 VDC) |
| Input Signal | Pulse width modulated |
| Connections | Two wires, open lead |

Mechanical Specifications:

| | |
|-------------------|--|
| Temperature Range | -40°F to +250°F (-40°C to +121°C) |
| Vibration | 15 G's from 50 to 500 Hz sinusoidal, 3-planes |
| Shock | 200 G's, 0-Peak @ 21 Hz |
| Housing | Anodized aluminum, sealed up to 3 psi for environmental protection |

| Engine Series | Stroke | Weight |
|----------------|-----------------|--------------------|
| Kubota Super 5 | 0.47" (12 mm) | 1.16 lbs (0.53 kg) |
| Kubota 3300 | 0.47" (12 mm) | 1.16 lbs (0.53 kg) |
| Mitsubishi SL | 0.53" (13.5 mm) | 1.28 lbs (0.58 kg) |
| Perkins 700 | 0.63" (16.0 mm) | 1.19 lbs (0.54 kg) |
| Yanmar TNE | 0.29" (7.4 mm) | 1.19 lbs (0.54 kg) |
| Yanmar 2V78 | 0.29" (7.4 mm) | 1.19 lbs (0.54 kg) |

SIDE MOUNTING

Actuator mounts directly to fuel pump in place of the fuel shutoff solenoid

Kubota Super 5
Perkins 700
Yanmar TNE
Yanmar 2V78

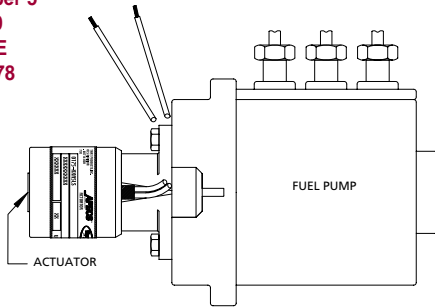

TOP MOUNTING

Kubota 3330

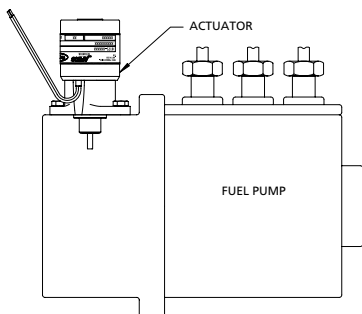

THREAD MOUNTING

Mitsubishi SL

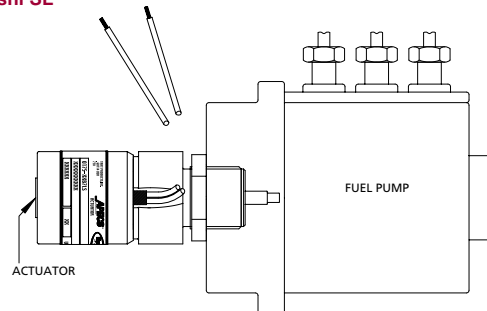

Linkage Free Integral-Type

KUBOTA SUPER 5 SERIES

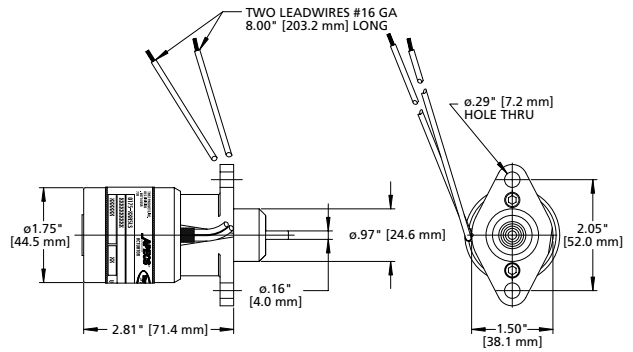

KUBOTA 3300 SERIES

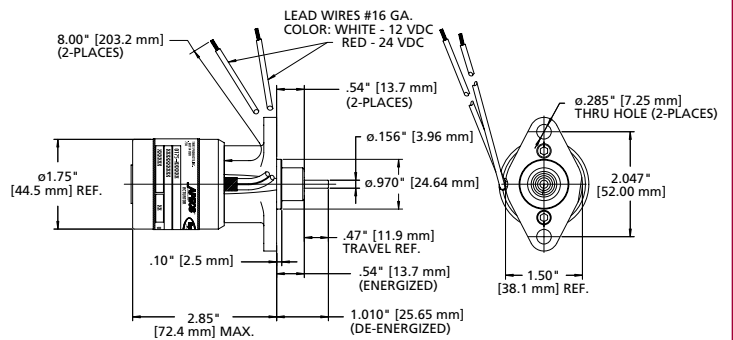

MITSUBISHI SL SERIES

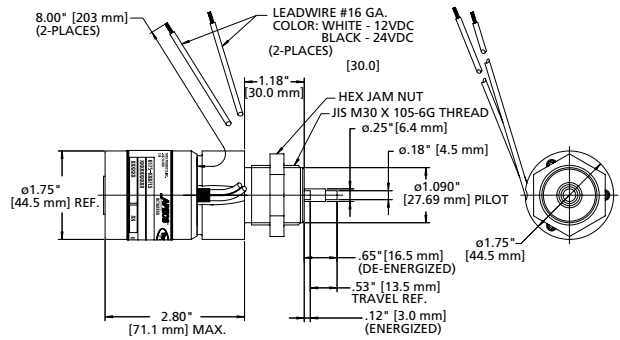

PERKINS 700 SERIES

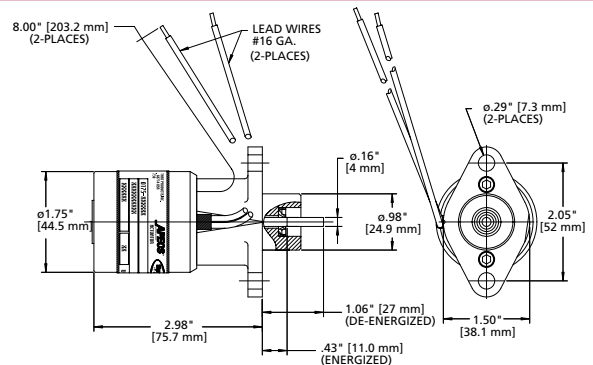

Linkage Free Integral-Type

YANMAR TNE SERIES

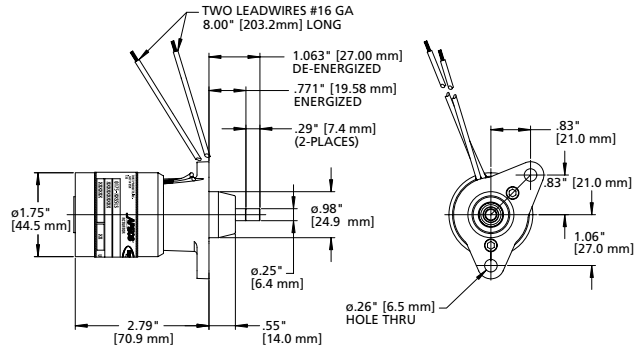

YANMAR 2V78 SERIES

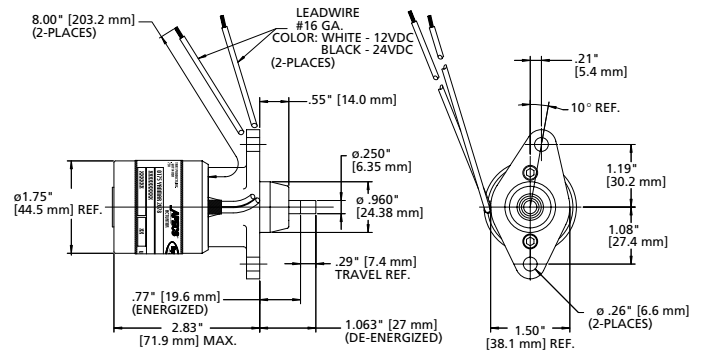

Specifications are for reference only.



WARNING: An overspeed shutdown device, independent of the APECS system, should be provided to prevent loss of engine control that may cause personal injury or equipment damage.

APECS® 0200R Rotary Actuator

Versatile rotary actuator is suitable for a variety of stationary and off-road engine applications. Direct connection eliminates the need for any external linkage.



Features:

- Angular position proportional to input coil current
- Direct interface between actuator and shut-off lever
- Multiple terminal connections available
- Spring return to minimum position
- Precise engine speed control when used with APECS electronic controllers (See Controllers section, pages 74-83, for ordering information)
- Withstands harsh temperature and vibration conditions
- Corrosion resistant housing with sealed plastic cover

Order Information:

| ORDER NO. | Voltage |
|------------|---------|
| SA-4928-12 | 12 VDC |
| SA-4928-24 | 24 VDC |

Torque vs. Rotation*

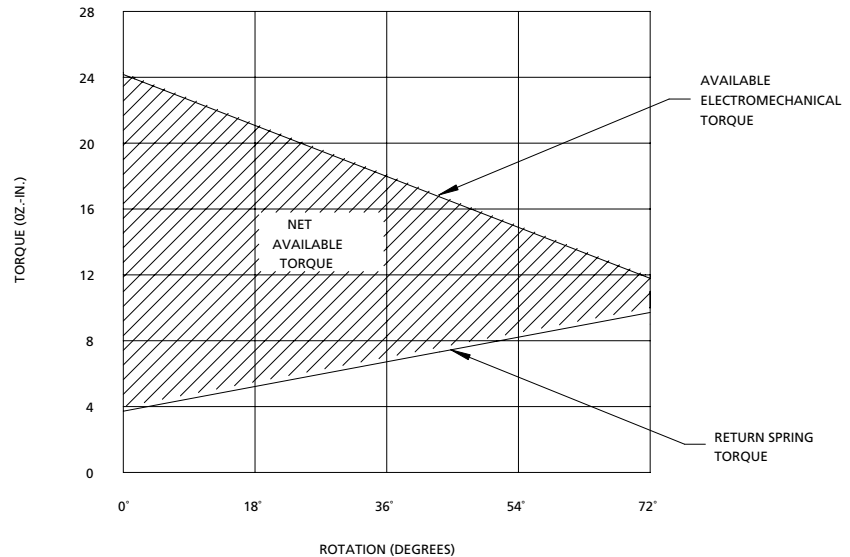

*At 68°F (20°C) and rated voltage



WARNING: An overspeed shutdown device, independent of the APECS system, should be provided to prevent loss of engine control that may cause personal injury or equipment damage.

E.E.C. Directive Compliance: All parts supplied by Woodward are classified as components, and therefore are not "CE" marked. Please contact factory direct for details on specific product compliance with 89/336/EEC and 89/392/EEC directives.

APECS® 0200R Rotary Actuator

DIMENSIONS

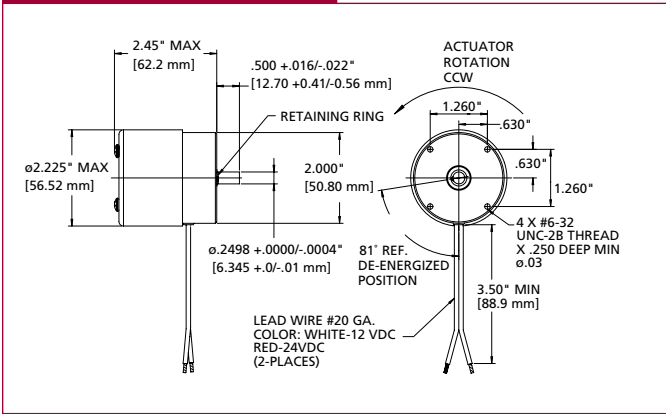

Electrical Specifications:

| | |
|-------------------------------|--|
| Rated Voltage | 12 or 24 VDC |
| Rated Current | 68°F(20°C) |
| Nominal Steady State | <u>12 Volt</u> <u>24 Volt</u> |
| Nominal Intermittent at Stall | 3.0 A 1.6 A |
| | 6.0 A 3.1 A |
| Response Time | 0.05 sec nominal ON time for 63% stroke |
| | 0.05 sec nominal OFF time for 63% stroke |

Mechanical Specifications:

| | |
|-------------------|-------------------------------------|
| Temperature Range | -40°F to + 221°F (-40°C to + 105°C) |
| Rotation | 72° (±2°) |
| Vibration | 15 G's |
| Shock | 200 G's |
| Sealing | Oil, water and dust resistant |
| Weight | 1.2 lbs (0.54 kg) |

Specifications are for reference only.

Engine Mounting Kits

Proportional fuel control for construction, industrial, and agricultural equipment. Maintains isochronous engine speed for demanding applications such as gensets, eliminating droop inherent in mechanical governors. Includes mounting hardware and control linkage for electronic engine governing systems.



Features:

- Fast, easy installation
- Corrosion resistant, plated steel bracket, linkage and hardware
- For use with APECS proportional actuators. (Vanguard kit includes O175 actuator)
- Precise engine speed control when used with APECS electronic controllers (See APECS Controllers section, pages 74-83, for ordering information)

Kits Available

- Cummins C Series
- Kubota V2203-E
- Vanguard 3/LC
DM-700D, DM-850D & DM-950D



WARNING: An overspeed shutdown device, independent of the APECS system, should be provided to prevent loss of engine control that may cause personal injury or equipment damage.

Engine Mounting Kits

Specifications:

| | |
|------------------------|--------------------------------------|
| Actuator Rated Voltage | 12 or 24 VDC |
| Temperature Range | -40°F to +250°F (-40°C to +121°C) |
| Input Signal | Pulse width modulated |
| Housing | Anodized aluminum |
| Connections | Two wires, open lead |

| | Rated Current | Stroke | Weight (excluding actuator) | Kit Contents |
|----------|------------------------------|--------------------|-----------------------------------|--|
| Cummins | 6.8 A-12 VDC 3.5 A-24 VDC | 1.00" (25.4 mm) | 1.4 lbs (0.64 kg) | Adapter plate, linkage, reinforcing bar for A & MW pump mounting hardware |
| Kubota | 6.8 A-12 VDC 3.5 A-24 VDC | 1.00" (25.4 mm) | 2.7 lbs (1.2 kg) | Mounting bracket, linkage, lever extension, mounting hardware |
| Vanguard | 4.3 A-12 VDC 2.3 A-24 VDC | 0.80" (20 mm) | 1.7 lbs (0.78 kg) | Actuator with welded bracket, linkage and mounting hardware |

Specifications are for reference only.

Engine Mounting Kits

Cummins C Series Kit

Kits are custom fit for Cummins C series engines that are equipped with an RSV governor on Bosch A, MW and P fuel pumps. Kit mounts horizontally on the side of the engine block behind the pump.

APECS linear actuator (ordered separately) responds in milliseconds to changes in current from a pulse width modulated signal generated by the controller. When the actuator is de-energized, an internal spring moves the shutoff lever to shutdown.



Kit for A and MW pumps shown with reinforcing bar

Kit for P Pump

Order Information:

Mounting Kit

APECS Proportional Actuators

| ORDER NO. | Application | ORDER NO. | Model | Spring | Voltage |
|-----------|---------------------------------------|------------|-------|--------------|---------|
| SA-4598 | Cummins C Series (A, MW & P pumps) | SA-4506-12 | 0250 | SA-4684 (S1) | 12 VDC |
| | | SA-4506-24 | 0250 | SA-4684 (S1) | 24 VDC |

When you order: Order bracket from Cummins if it is not already on the engine:

| PUMP MODEL | Bracket |
|------------|-------------|
| A | No. 3923254 |
| MW | No. 3923255 |
| P | No. 3930290 |

E.E.C. Directive Compliance: All parts supplied by Woodward are classified as components, and therefore are not "CE" marked. Please contact factory direct for details on specific product compliance with 89/336/EEC and 89/392/EEC directives.

Engine Mounting Kits

Kubota V2203-E Kit

The Kubota V2203-E kit mounts closely behind the fuel pump.

APECS linear proportional actuator (ordered separately) responds in milliseconds to changes in current from a pulse width modulated signal generated by the controller. When the actuator is de-energized, an internal spring moves the shutoff lever to shutdown.



Order Information:

Mounting Kit

| ORDER NO. | Application |
|----------------|----------------|
| SA-4457 | Kubota V2203-E |

APECS Proportional Actuators

| ORDER NO. | Model | Spring | Voltage |
|-------------------|-------|--------------|---------|
| SA-4502-12 | 0251 | SA-4684 (S1) | 12 VDC |
| SA-4502-24 | 0251 | SA-4684 (S1) | 24 VDC |

Vanguard 3/LC DM-700D, DM-850D & DM-950D Kit

The Vanguard 3/LC kit mounts closely above the front gear housing, behind the fan, to minimize interference with other components or housing.

APECS linear proportional actuator responds in milliseconds to changes in current from a pulse width modulated signal generated by the controller. When the actuator is de-energized, an internal spring moves the shutoff lever to shutdown.



Order Information:

Mounting Kit

| ORDER NO. | Application |
|-------------------|----------------------------|
| SA-4779-12 | Vanguard 3/LC (all models) |
| SA-4779-24 | Vanguard 3/LC (all models) |

APECS Proportional Actuators

| ORDER NO. | Model | Spring | Voltage |
|-----------------|-------|----------|---------|
| Included in Kit | 0175 | Included | 12 VDC |
| Included in Kit | 0175 | Included | 24 VDC |

Note: The throttle lever with an extra hole must be ordered from Briggs and Stratton Daihatsu in the U.S.

Linkage Hardware

Linkage components connect the actuator shaft to the engine control lever. A good linkage contributes to accurate, stable and responsive performance with minimal play or friction.



Features:

- Allows for minor misalignments
- Minimal friction, binding and backlash
- Threaded rod for longer linkages
- Spherical male and female rod-end bearings for shorter linkages
- Built to withstand extreme conditions
- Corrosion resistant

Kit Contents:

Long Linkage Kit includes:

- (1) Threaded rod
- (4) Hex nuts
- (4) Split lockwashers
- (1) Hex screw
- (2) Rod ends, female
- (1) Clevis

Short Linkage Kit includes:

- (3) Hex nuts
- (3) Split lockwashers
- (1) Hex screw
- (1) Rod end, female
- (1) Rod end, male
- (1) Clevis

Order Information:

APECS Linkage Kits

| ORDER NO. | Description | Thread Size | Center to center of spherical rod ends | |
|----------------|-------------------|-------------|--|----------------|
| | | | Minimum Length | Maximum Length |
| SA-4661 | Long Linkage Kit | ¼-28 | 3.3" | 7.9" |
| SA-4845 | Long Linkage Kit | M6 | 83.8 mm | 200.6 mm |
| SA-4742 | Short Linkage Kit | ¼-28 | 2.2" | 2.6" |
| SA-4844 | Short Linkage Kit | M6 | 55.8 mm | 66.0 mm |

Individual APECS Kit Components

ORDER NO. for Thread Size:

| ¼-28 | M6 | Description |
|----------------|----------------|--|
| SA-4599 | SA-4804 | Clevis (fits actuators to the rod ends sold below) |
| SA-4619 | SA-4843 | Spherical rod end, female |
| SA-4600 | SA-4842 | Spherical rod end, male |
| SA-4602 | SA-4846 | Long threaded rod |

E.E.C. Directive Compliance: All parts supplied by Woodward are classified as components, and therefore are not "CE" marked. Please contact factory direct for details on specific product compliance with 89/336/EEC and 89/392/EEC directives.

Linkage Hardware

Assembled Kits:

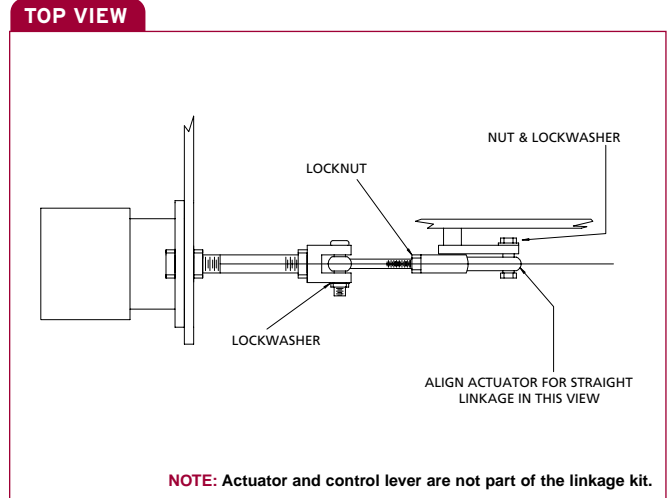
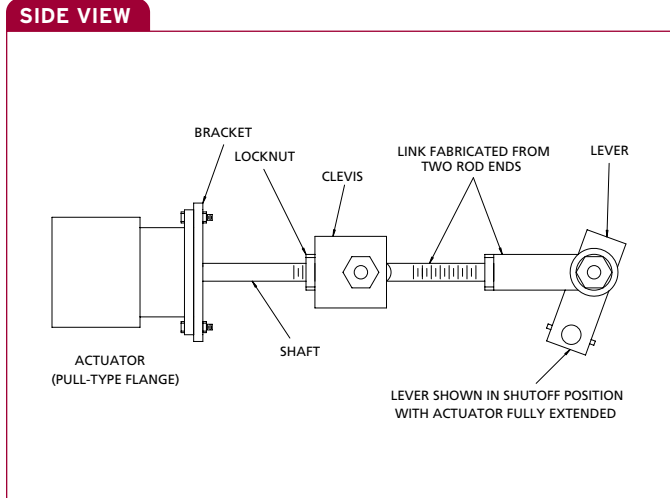

Kit Components:

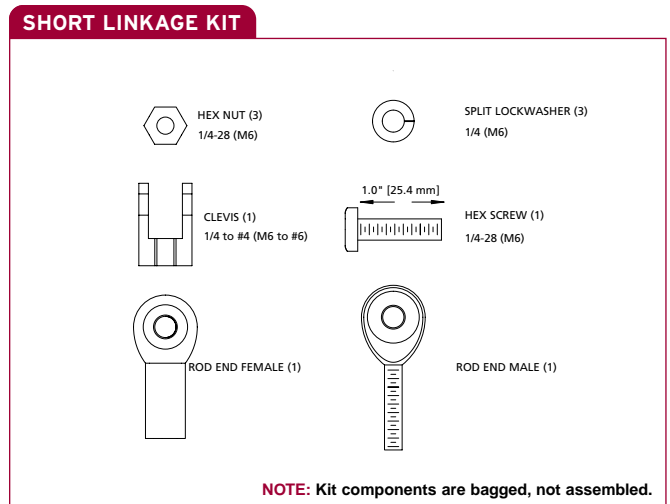
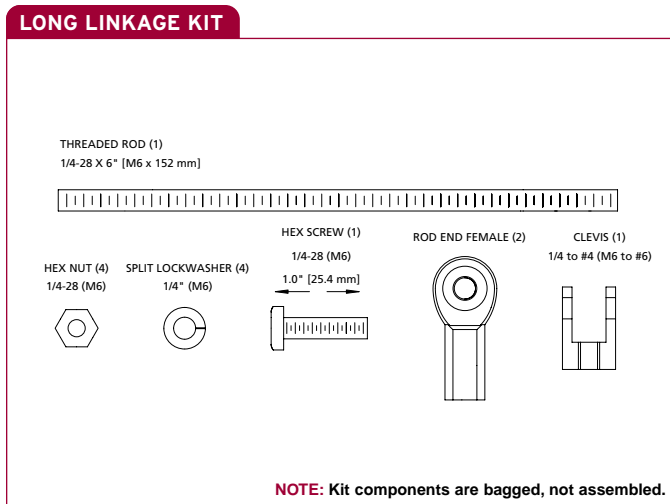

WARNING: An overspeed shutdown device, independent of the APECS system, should be provided to prevent loss of engine control that may cause personal injury or equipment damage.

Part No. Index

| | | | | | |
|-------------------|-------|------------------|-------|------------------|---------|
| SA-0008-A | 41 | SA-3799-12 | 45 | SA-4455 | 76-77 |
| SA-0293-B | 41 | SA-3799-24 | 45 | SA-4457 | 99 |
| SA-1707-003 | 65 | SA-3800-12 | 45 | SA-4467 | 78-79 |
| SA-1707-008 | 65 | SA-3800-24 | 45 | SA-4468 | 78-79 |
| SA-1707-010 | 65 | SA-3999-12 | 49 | SA-4469 | 78-79 |
| SA-1707-014 | 65 | SA-3999-24 | 49 | SA-4470 | 78-79 |
| SA-1707-015 | 65 | SA-4014-12 | 49 | SA-4471 | 76-77 |
| SA-1707-020 | 65 | SA-4014-24 | 49 | SA-4472 | 84-85 |
| SA-1707-030 | 65 | SA-4026-12 | 44 | SA-4473 | 78-79 |
| SA-1707-035 | 65 | SA-4026-24 | 44 | SA-4475 | 78-79 |
| SA-1707-050 | 65 | SA-4049 | 40 | SA-4478 | 62-63 |
| SA-2170 | 64-65 | SA-4050 | 40 | SA-4479 | 62-63 |
| SA-2171A | 64-65 | SA-4092-12 | 38-39 | SA-4486 | 82 |
| SA-2214 | 57 | SA-4092-24 | 38-39 | SA-4488 | 80 |
| SA-2650A | 68 | SA-4094-12 | 38-39 | SA-4489 | 80 |
| SA-2652A | 68 | SA-4094-24 | 38-39 | SA-4490 | 80 |
| SA-2657 | 58-59 | SA-4188 | 41 | SA-4502-12 | 99 |
| SA-2658 | 58-59 | SA-4220-12 | 38-39 | SA-4502-24 | 99 |
| SA-2659 | 58-59 | SA-4220-24 | 38-39 | SA-4506-12 | 98 |
| SA-2660 | 58-59 | SA-4222-12 | 38-39 | SA-4506-24 | 98 |
| SA-2685A | 68 | SA-4222-24 | 38-39 | SA-4573-12 | 90-91 |
| SA-2763A | 68 | SA-4224-12 | 38-39 | SA-4573-24 | 90-91 |
| SA-2772A | 68 | SA-4224-24 | 38-39 | SA-4574-12 | 90-91 |
| SA-2888A | 68 | SA-4232 | 41 | SA-4574-24 | 90-91 |
| SA-2961 | 69 | SA-4259-12 | 47 | SA-4598 | 98 |
| SA-2962 | 69 | SA-4260-12 | 47 | SA-4599 | 100-101 |
| SA-2968 | 41 | SA-4260-24 | 47 | SA-4600 | 100-101 |
| SA-2968-UK | 41 | SA-4264 | 47 | SA-4602 | 100-101 |
| SA-3157 | 40 | SA-4268-12 | 46 | SA-4619 | 100-101 |
| SA-3158 | 40 | SA-4269-12 | 46 | SA-4624-12 | 32-33 |
| SA-3159 | 40 | SA-4270 | 46 | SA-4624-24 | 32-33 |
| SA-3160 | 40 | SA-4280 | 41 | SA-4626-12 | 32-33 |
| SA-3316 | 58-59 | SA-4389 | 74-75 | SA-4626-24 | 32-33 |
| SA-3317 | 58-59 | SA-4423 | 64-65 | SA-4630-12 | 32-33 |
| SA-3725 | 48 | SA-4424 | 64-65 | SA-4634-12 | 32-33 |
| SA-3742-12 | 45 | SA-4450 | 76-77 | SA-4634-24 | 32-33 |
| SA-3742-24 | 45 | SA-4451 | 76-77 | SA-4661 | 100-101 |
| SA-3765-12 | 45 | SA-4452 | 76-77 | SA-4684 | 86-87 |
| SA-3765-24 | 45 | SA-4453 | 76-77 | SA-4685 | 86-87 |

Part No. Index

| | | | |
|------------------|---------|------------------|-------|
| SA-4686-12 | 32-33 | SA-4848-24 | 90-91 |
| SA-4686-24 | 32-33 | SA-4899-12 | 50 |
| SA-4687-12 | 32-33 | SA-4899-24 | 50 |
| SA-4687-24 | 32-33 | SA-4928-12 | 94-95 |
| SA-4690-12 | 37 | SA-4928-24 | 94-95 |
| SA-4690-24 | 37 | SA-4945 | 35 |
| SA-4691-24 | 37 | SA-4971 | 24-25 |
| SA-4703 | 84-85 | SA-4972 | 24-25 |
| SA-4704 | 84-85 | SA-5028 | 34 |
| SA-4713 | 88-89 | SA-5160 | 34 |
| SA-4714 | 88-89 | SE-5559 | 40 |
| SA-4727-12 | 37 | SE-5601 | 40 |
| SA-4727-24 | 37 | SE-5614 | 40 |
| SA-4728 | 86-87 | | |
| SA-4729 | 86-87 | | |
| SA-4741 | 26-27 | | |
| SA-4742 | 100-101 | | |
| SA-4744-12 | 22-23 | | |
| SA-4744-24 | 22-23 | | |
| SA-4751 | 35 | | |
| SA-4759 | 35 | | |
| SA-4777-12 | 90-91 | | |
| SA-4777-24 | 90-91 | | |
| SA-4779-12 | 99 | | |
| SA-4779-24 | 99 | | |
| SA-4804 | 100-101 | | |
| SA-4822-12 | 32-33 | | |
| SA-4828-12 | 90-91 | | |
| SA-4828-24 | 90-91 | | |
| SA-4829 | 88-89 | | |
| SA-4837-12 | 90-91 | | |
| SA-4837-24 | 90-91 | | |
| SA-4842 | 100-101 | | |
| SA-4843 | 100-101 | | |
| SA-4844 | 100-101 | | |
| SA-4845 | 100-101 | | |
| SA-4846 | 100-101 | | |
| SA-4848-12 | 90-91 | | |

Product Index

A

| | |
|----------------------|-----|
| Accessories | |
| Actuator | 100 |
| APECS | 73 |
| Solenoid | 30 |
| ACT Calibration Tool | 73 |
| Actuator Accessories | 100 |
| Actuator Kits | |
| Cummins C Series | 98 |
| Kubota Engines | 99 |
| Vanguard Engines | 99 |

| | |
|----------------------------|----|
| Actuators | |
| Linear Proportional | 84 |
| Linkage Free Integral-Type | 90 |
| Rotary Proportional | 94 |

| | |
|------------------|----|
| APECS | |
| Accessories | 73 |
| Actuator Kits | 96 |
| Actuators | 84 |
| Basics | 70 |
| Calibration Tool | 73 |
| Controllers | 74 |

B

| | |
|---------------------------|----|
| Basics | |
| APECS | 70 |
| Electronic Speed Switches | 52 |
| Solenoid | 2 |
| Timer Module | 30 |

C

| | |
|------------------------------|----|
| Cable Solenoid | 22 |
| Calibration Tool | |
| APECS 3000 | 76 |
| APECS 4000 | 78 |
| APECS 4500 | 80 |
| APECS 5000 | 82 |
| EPS 1000 | 62 |
| Coil Commanders | |
| 5-Wire | 32 |
| 6-Wire | 34 |
| 7-Wire | 36 |
| Clevis Yoke | 41 |
| Clevis Yoke Bead Chain Assy. | 41 |
| Connector & Cable Assy | 65 |
| Controllers | |
| APECS 2000 | 74 |
| APECS 3000 | 76 |
| APECS 4000 | 78 |
| APECS 4500 | 80 |
| APECS 5000 | 82 |
| Connector Kit | 78 |
| Cummins C Series Engines | 98 |

D

| | |
|---------------------|----|
| Drive Tangs | 69 |
| Dual Coil Solenoids | |
| 1500 Series | 12 |
| 1750 Series | 14 |
| 1750 Push Series | 16 |
| 2000 Series | 18 |
| 2370 Series | 20 |
| Cable Solenoid | 22 |

E

| | |
|---------------------------|----|
| Electronic Speed Switches | |
| Basics | 52 |
| EPS 1000 | 62 |
| ESSB | 56 |
| ESSD | 58 |
| ESSE Series | 60 |
| End Cap | 40 |
| Engine Mounting Kits | |
| Cummins | 98 |
| Kubota | 99 |
| Vanguard | 99 |
| EPS 1000 | 62 |

H

| | |
|----------|-----|
| Hardware | |
| Linkage | 100 |
| Solenoid | 40 |

I

| | |
|----------------|----|
| In-line Swivel | 40 |
|----------------|----|

K

| | |
|----------------------|----|
| Kubota | |
| 3300 Series Actuator | 90 |
| Shutdown Kit | 46 |
| Shutdown Solenoid | 50 |
| Super 5 Series | 90 |
| V2203-E Engine Kit | 99 |

L

| | |
|------------------------|-----|
| Linear Proportional | 84 |
| Linkage Free Actuators | 90 |
| Linkage Hardware | 100 |
| Locking Solenoid | 24 |

M

| | |
|------------------------|----|
| Magnetic Pickups | 64 |
| Mini-Gen | 66 |
| Mitsubishi | |
| L Series Shutdown Kits | 48 |
| SL Series Actuators | 90 |

P

| | |
|-------------------------|----|
| Perkins 700 Series | 90 |
| Protection Systems | |
| Equipment | 62 |
| Solenoid | 30 |
| Pull Coil Timer Modules | 38 |
| PVC Terminal Protector | 41 |

R

| | |
|-----------------------|----|
| Rotary Actuator | 94 |
| RQV-K Bosch | 44 |
| RSV Bosch | 45 |
| RSV Zexel Nippondenso | 49 |

S

| | |
|---------------------------|----|
| Single Coil Solenoids | |
| 1000 S Series | 24 |
| 1503 S Series | 26 |
| 2370 S Series | 28 |
| Solenoid Accessories | |
| Hardware | 40 |
| Timer Modules | 30 |
| Solenoid Shutdown Systems | |
| Kubota 1A | 46 |
| Kubota 3A | 47 |
| Kubota D722 & Z482 | 50 |
| Mitsubishi L | 48 |
| RQV-K Bosch | 44 |
| RSV Bosch | 45 |
| RSV Zexel Nippondenso | 49 |

| | |
|------------------|----|
| Solenoids | |
| Accessories | 30 |
| Basics | 2 |
| Cable | 22 |
| Dual Coil | 11 |
| Locking | 24 |
| Shutdown Systems | 42 |
| Single Coil | 24 |

| | |
|-------------------|----|
| Speed Sensors | |
| Magnetic Pickups | 64 |
| Mini-Gens | 66 |
| Spherical Rod End | 41 |
| Spring Swivel | 40 |

T

| | |
|---------------|----|
| Timer Modules | 30 |
|---------------|----|

V

| | |
|--------------------|----|
| Vanguard Engines | 99 |
| Vibration Isolator | 57 |

Y

| | |
|----------------|----|
| Yanmar Engines | 90 |
|----------------|----|

