

**L-Series ITB
LC-50**

Installation, Programming, & Troubleshooting

OEM/Dealer Manual

IMPORTANT



This is the safety alert symbol. It is used to alert you to potential personal injury hazards. Obey all safety messages that follow this symbol to avoid possible injury or death.

DEFINITIONS

- **DANGER**—Indicates a hazardous situation which, if not avoided, will result in death or serious injury.
- **WARNING**—Indicates a hazardous situation which, if not avoided, could result in death or serious injury.
- **CAUTION**—Indicates a hazardous situation which, if not avoided, could result in minor or moderate injury.
- **NOTICE**—Indicates a hazard that could result in property damage only (including damage to the control).
- **IMPORTANT**—Designates an operating tip or maintenance suggestion.

WARNING

The engine, turbine, or other type of prime mover should be equipped with an overspeed shutdown device to protect against runaway or damage to the prime mover with possible personal injury, loss of life, or property damage.

The overspeed shutdown device must be totally independent of the prime mover control system. An overtemperature or overpressure shutdown device may also be needed for safety, as appropriate.



Read this entire manual and all other publications pertaining to the work to be performed before installing, operating, or servicing this equipment. Practice all plant and safety instructions and precautions. Failure to follow instructions can cause personal injury and/or property damage.



This publication may have been revised or updated since this copy was produced. To verify that you have the latest revision, be sure to check the *publications page* on the Woodward website:

www.woodward.com/publications

The current revision and distribution restriction of all publications are shown in manual **26311**.

The latest version of most publications is available on the *publications page*. If your publication is not there, please contact your customer service representative to get the latest copy.



Any unauthorized modifications to or use of this equipment outside its specified mechanical, electrical, or other operating limits may cause personal injury and/or property damage, including damage to the equipment. Any such unauthorized modifications: (i) constitute "misuse" and/or "negligence" within the meaning of the product warranty thereby excluding warranty coverage for any resulting damage, and (ii) invalidate product certifications or listings.

NOTICE

To prevent damage to a control system that uses an alternator or battery-charging device, make sure the charging device is turned off before disconnecting the battery from the system.

NOTICE

To prevent damage to electronic components caused by improper handling, read and observe the precautions in Woodward manual **82715**, *Guide for Handling and Protection of Electronic Controls, Printed Circuit Boards, and Modules*.

■ Revisions—Text changes are indicated by a black line alongside the text.

Woodward reserves the right to update any portion of this publication at any time. Information provided by Woodward is believed to be correct and reliable. However, no responsibility is assumed by Woodward unless otherwise expressly undertaken.

Contents

REGULATORY COMPLIANCE	ii
CHAPTER 1. GENERAL INFORMATION.....	1
Purpose and Scope	1
Intended Applications	1
Introduction	1
CHAPTER 2. APPLICATION OVERVIEW.....	2
Hardware Configuration Application Process.....	2
CHAPTER 3. INSTALLATION.....	4
Mechanical Installation	4
LC-50 Applications (Mixer Applications).....	9
CHAPTER 4. TROUBLESHOOTING	11
CHAPTER 5. PRODUCT SUPPORT AND SERVICE OPTIONS.....	12
Product Support Options	12
Product Service Options.....	12
Returning Equipment for Repair	13
Replacement Parts	13
Engineering Services.....	14
Contacting Woodward's Support Organization	14
Technical Assistance.....	15
L-SERIES ITB SPECIFICATIONS	17
APPENDIX. ACRONYMS/ABBREVIATIONS.....	17
DECLARATIONS.....	18

Illustrations and Tables

Figure 2-1. Application Matrix.....	2
Figure 3-1. Spring-loaded Throttle Plate	5
Figure 3-2. L-Series ITB Outline Drawings.....	6
Figure 3-3a. LC-50 Outline Drawing (small bore)	7
Figure 3-3b. LC-50 Outline Drawing (large bore)	8
Figure 3-4. Zirconia Oxygen Sensor Response	10
Figure 3-5. Pre-Catalyst Emissions.....	10
Figure 3-6. Post-Catalyst Emissions	10

Regulatory Compliance

European Compliance for CE Marking:

These listings are limited only to those units bearing the CE Marking:

EMC Directive: Declared to 89/336/EEC COUNCIL DIRECTIVE of 03 May 1989 on the approximation of the laws of the Member States relating to electromagnetic compatibility.

These listings are limited only to those L-Series ITB Control units (not mixers) bearing the ATEX markings as well as the CE Mark:

ATEX – Potentially Explosive Atmospheres Directive: Declared to 94/9/EC COUNCIL DIRECTIVE of 23 March 1994 on the approximation of the laws of the Member States concerning equipment and protective systems intended for use in potentially explosive atmospheres.
Zone 2, Category 3, Group II G, EEx nA II T3 X
–40 °C ≤ Tamb ≤ 105 °C, IP56

Special Condition for Safe Use: The installer of the L-series must take responsibility for meeting Sub-Clause 26.3.3.1 of EN60079-15:2003 regarding impact testing. The actuator by itself does not meet this requirement and therefore must be sufficiently protected when installed. See Chapter 2: Mechanical Installation for more detail.

Other European and International Compliance:

Compliance with the following European Directives or standards does not qualify this product for application of the CE Marking:

Machinery Directive: Compliant as a component with 98/37/EC COUNCIL DIRECTIVE of 23 July 1998 on the approximation of the laws of the Member States relating to machinery.

Pressure Equipment Directive: Exempt per Article 1-3.10

Wiring must be in accordance with North American Class I, Division 2 or European Zone 2, Category 3 wiring methods as applicable, and in accordance with the authority having jurisdiction.

Field wiring must be suitable for at least 105 °C.

Connect ground terminal to earth ground.

The actuator should be protected from exposure to sunlight and rain.

WARNING

EXPLOSION HAZARD—Do not connect or disconnect while circuit is live unless area is known to be non-hazardous.

Substitution of components may impair suitability for Class I, Division 2 or Zone 2 applications.

Do not clean equipment unless power has been switched off or the area is known to be non-hazardous.

AVERTISSEMENT

RISQUE D'EXPLOSION—N'effectuez aucune connexion ou déconnexion tandis que le circuit est sous tension, sauf s'il s'est avéré que la zone n'est pas dangereuse.

Le remplacement de composants peut rendre ce matériel inacceptable pour les emplacements de Classe I, Division 2 ou Zone 2.

Chapter 1.

General Information

Purpose and Scope

The purpose of this manual is to provide OEMs with the necessary background information for applying the L-Series ITB and LC-50 control to gas/gasoline reciprocating engines. Topics covered include mechanical installation and setup and troubleshooting. For application setup, please refer to manual 26237 (Position Control), manual 26250 (L-Series Speed Control), or manual 26251 (L-Series Process Control). While the ITB/LC-50 manual is primarily targeted at OEM customers, OEMs themselves may find it useful to copy some of the information from this manual into their application user manuals.

Intended Applications

The L-Series ITB and LC-50 controls are designed primarily for various industrial applications, including generator sets, welders, portable refrigeration units, irrigation pumps, chipper shredders, and mobile industrial gas or gasoline reciprocating engines. Key environmental characteristics of these applications include industrial operating temperatures (−40 to +105 °C/−40 to +221 °F).



The L-Series control should not be used as the primary means of shutting down the engine.

Introduction

The L-Series ITB and LC-50 provide a building block approach to total engine management. The modular design consist of a die-cast aluminum throttle body, a mixer, and a fully programmable integrated digital speed, position or process control, and bi-directional actuator. The L-Series ITB incorporates the Woodward L-Series control with a throttle plate. The LC-50 adds a venturi-style annular ring mixer to the L-Series ITB.

Chapter 2. Application Overview

Hardware Configuration Application Process

The first step in configuring a new system is to choose the appropriate hardware for the application. An ITB, a mixer, and a version of the actuator must be selected. The ITBs and mixers come in five different sizes.

For both the L-Series ITB and LC-50, the user must choose the appropriately sized ITB for the application. The chart below illustrates how to choose the proper size. The intersection of the operating rpm and the engine displacement will fall within a specific ITB band. For example, a 4.0 L engine that will run at 2000 rpm would need a 43 mm ITB, as that point falls between the two lines for the 43 mm (square marker lines).

If the application will have multiple speed set points, some judgment needs to be used to appropriately size the throttle. In general, the highest speed where the engine will spend any significant percentage of its time, or the highest speed where efficiency (or power) is important, should be used for sizing.

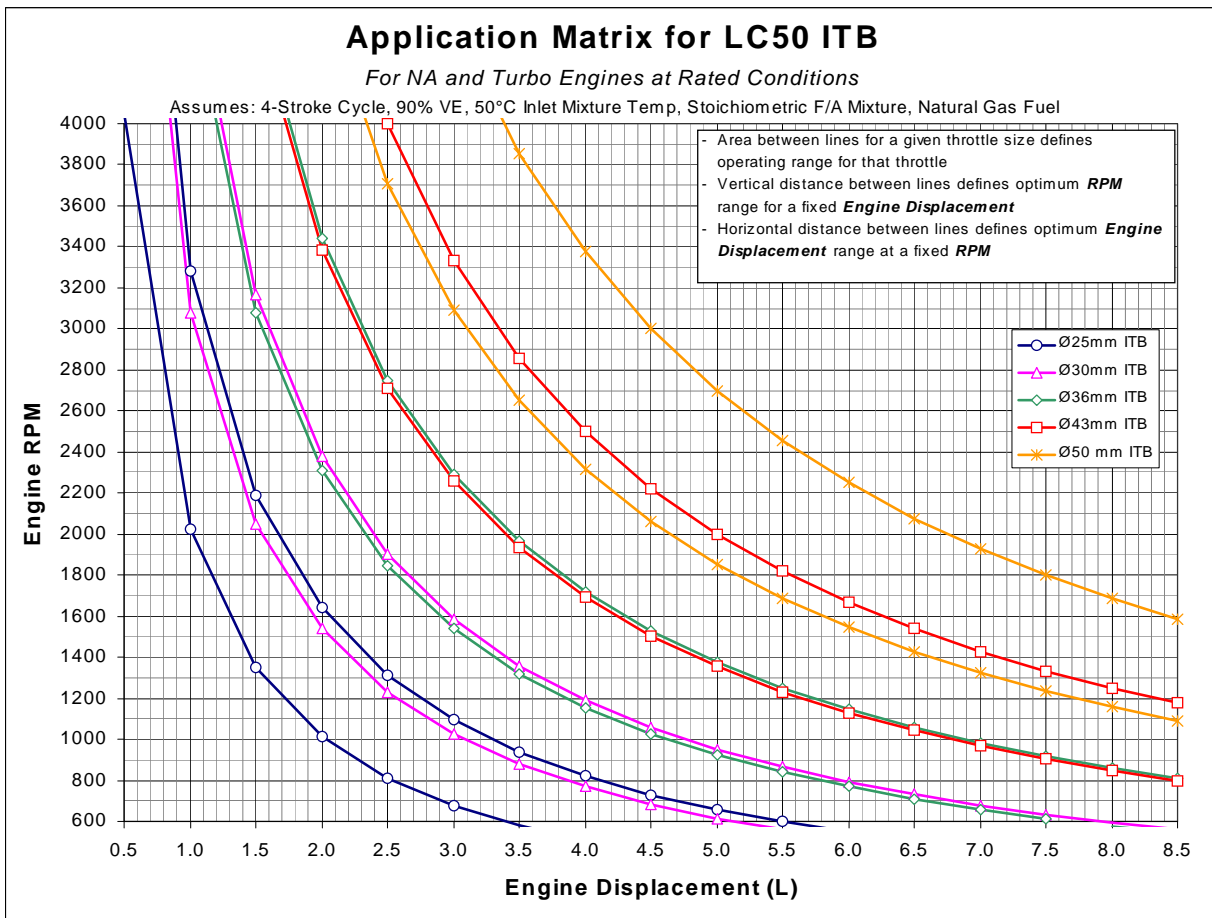

Figure 2-1. Application Matrix

If the application is an LC-50 product, there are appropriately sized mixers for each throttle size. A complete gaseous fuel delivery system requires:

- a fixed main adjustment screw (MAS) or closed-loop trim valve
- a zero-pressure regulator (ZPR)
- a fuel shut-off valve

The LC-50 comes with a venturi-style mixer. By locally increasing the air speed in a pipe, the static pressure at the location of the restriction will be lower than the pressure before this restriction. When a number of orifices are made in the circumference of the venturi, the medium to be mixed (natural gas) will be drawn into the venturi throat. If the pressure of the gas is kept equal to the pressure before the venturi, the gas will be mixed with the air in a constant ratio. The pressure is kept equal to the air pressure directly before the mixer by means of a zero pressure regulator and a compensation line. The venturi mixer is maintenance free.

A main adjustment screw (MAS) is provided to adjust the full-power air/fuel ratio by means of an adjustable restriction in the fuel line between the zero pressure regulator and the venturi mixer. For more advance A/F ratio control, an L-Series O₂ sensing A/F ratio trim valve is available separately as a replacement for the MAS. The LC-50 Mixer fuel inlet connection is designed to match the L-Series trim valve bolt pattern. For more information, refer to product specification 03255.

The compensation line ensures that the gas pressure is kept equal to the air pressure before the venturi mixer. When no compensation line is used, the outlet pressure of the ZPR will not be balanced as the air filter becomes dirty. As the air filter gets dirty, there is an increased pressure drop after the air filter, and the air/fuel ratio will become richer.

Chapter 3. Installation

WARNING

When included with an ITB, the actuator depends solely on the return spring inside the throttle body assembly to drive toward minimum fuel when not powered. Therefore other positive shutdown devices like fuel shut-off solenoids are recommended to ensure shutdown on loss of signal to the control system. Also, separate overspeed trip devices are always mandatory.

WARNING

External fire protection is not provided in the scope of this product. It is the responsibility of the user to satisfy any applicable requirements for their system.

CAUTION

Due to typical noise levels in turbine or engine environments, hearing protection should be worn when working on or around the L-Series.

CAUTION

The surface of this product can become hot enough or cold enough to be a hazard. Use protective gear for product handling in these circumstances. Temperature ratings are included in the specification section of this manual.

IMPORTANT

To meet ATEX Hazardous Location requirements, the installer of the L-Series must take responsibility for meeting Sub-Clause 26.3.3.1 of EN60079-15:2003 regarding impact testing. The actuator by itself does not meet this requirement and therefore must be sufficiently protected when installed. According to EN60079-15, the protection must be such that a 1 kg mass, fitted with an impact head in the form of a hemisphere of 25 mm diameter, can be dropped vertically from a height of 0.7 meter, and not cause significant damage to the actuator.

Mechanical Installation

Locate the L-Series control a distance from sources of extreme radiant heat, such as exhaust manifolds or turbochargers. The operating temperature range of the control is -40 to $+105$ °C (-40 to $+221$ °F). In spark-ignited applications, make sure the control is located away from the ignition coil, and that harness wires are not routed next to the spark plug wires.

While it is not a requirement, it is good practice to orient the connector feature on the control in a horizontal or downward orientation to minimize fluid accumulation between the enclosure and the mating connector's gasket.

IMPORTANT

For ATEX Hazardous Location applications, the installer of the L-series ITB Control must ensure that the mounting screws provide sufficient grounding for the ITB.

The 25, 30, and 36 mm throttles mount with 5 mm fasteners in a 43 mm square bolt pattern. The 43 and 50 mm throttles use 6 mm mounting screws in a 57 mm square pattern.

Mounting gaskets are not included with the Integrated Throttle Bodies (ITB), but these can be ordered separately as needed. For the 25, 30, and 36 mm ITBs, order gasket part number 0014-00-034. For the 43 and 50 mm ITBs, order gasket part number 0108-00-021.

The L-Series actuator has a rotation of 0–60 degrees. To get full blade rotation on the ITB, a mechanical linkage exists inside the ITB that converts 0 to 60 degrees actuator rotation to 3 to 85 degrees blade position. In addition, the ITB incorporates the use of an internal return spring. The spring load drives the throttle plate to the closed position with the clocking outlined in the figure below.

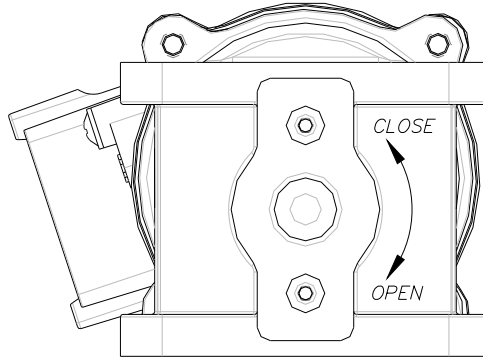

Figure 3-1. Spring-loaded Throttle Plate

The LC-50 mixer can be mounted in any of three orientations of the ITB to allow convenient fuel system connections. The L-Series ITB and LC-50 are intended to be used with gaseous fuels from low quality pipeline natural gas to HD-5 LPG. The quality of this range of fuel varies from a lower heating value of 850 BTU/SCF (34.0 MJ/m³) to 2325 BTU/SCF (93.0 MJ/m³), and the specific gravity varies from 0.55 to 1.56 relative to air. When using a Woodward supplied ZPR, fuel pressure should be 0.25 psi (7" water column) (1.7 kPa [178 mm water column]) to 1 psi (28" water column) (6.9 kPa [711 mm water column]). Pressure supply range is 4–14" water for the R500Z, and 4–28" water for the R600Z.

The LC-50 mixer has two inlet sizes for air filter attachment. The smaller throttles (25, 30, and 36 mm) have a 2.0-inch (50.8 mm) inlet. The larger throttles (43 and 50 mm) have a 2.5 inch (63.5 mm) inlet.

It is recommended that all components of the gas system, such as air filter, main adjustment screw, and throttle valve, be installed in a symmetric way to minimize the possibility of unequal mixture distribution.

Curved pipes should not be installed closer to the venturi than 3D (where D is the diameter of the venturi at the air inlet side).

Woodward recommends that you install a compensation line between the ZPR and the air inlet to maintain consistent air/fuel ratio throughout the life of the system. If a compensation line is not installed, the air/fuel ratio will be affected by the changing restriction of the air cleaner as it accumulates dirt.

If the Maxitrol ZPR is obtained from Woodward (part numbers 0055-55-062 for the R500Z [1/2" bore], 0055-00-063 for the R600Z [3/4" bore]), the following installation instructions apply. If another brand of ZPR is used, consult that manufacturer for installation guidelines. The ZPR should be mounted with the spring tower up. If it is not, the weight of the diaphragm and spring can offset the pressure setting. The ZPR should be mounted as close to the MAS as possible to prevent pressure drop across excessively long pipe lengths. This pressure drop and associated system lag can cause stability and response issues with the mixer air/fuel ratio control.

BORE Ø: 25MM, 30MM, & 36MM
MM [INCH]

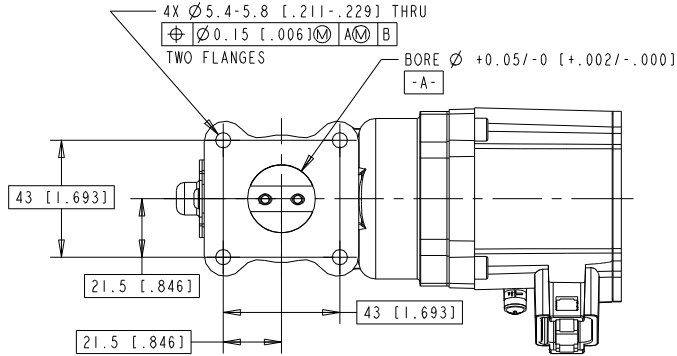
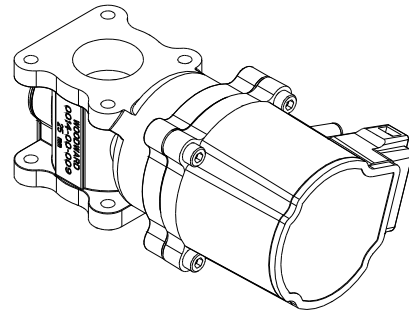
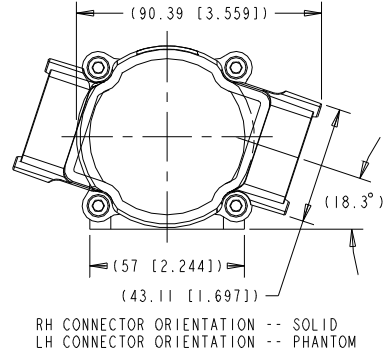
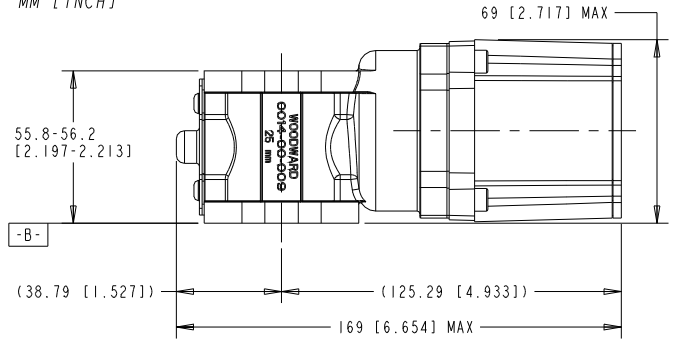

262-131
05-5-10

BORE Ø: 43MM & 50MM
MM [INCH]

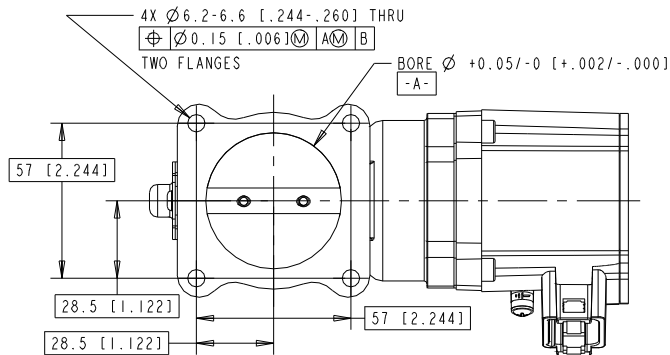
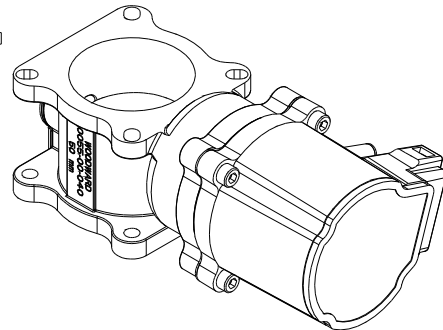
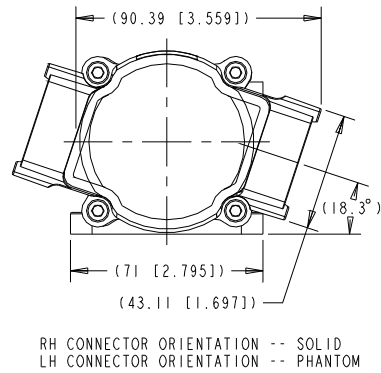
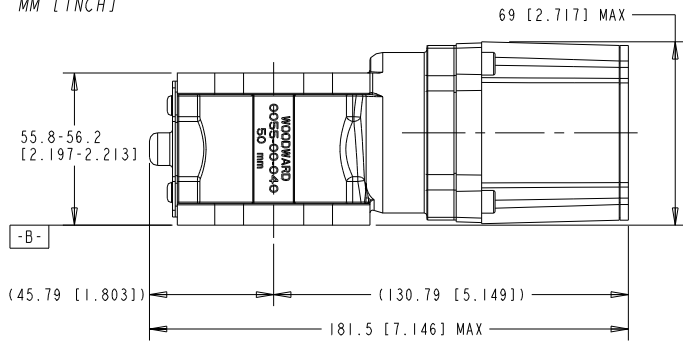

Figure 3-2. L-Series ITB Outline Drawings

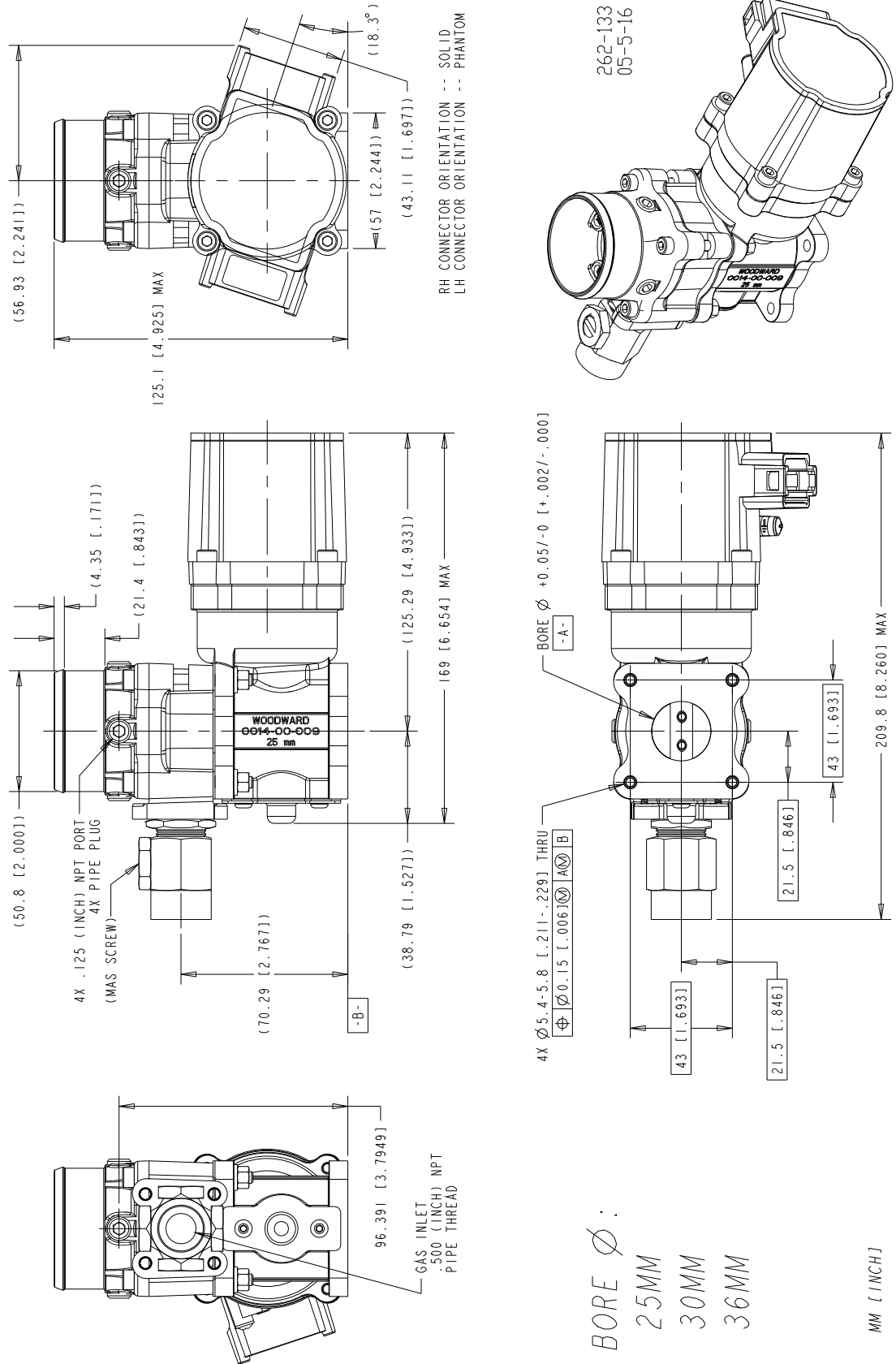

Figure 3-3a. LC-50 Outline Drawing (small bore)

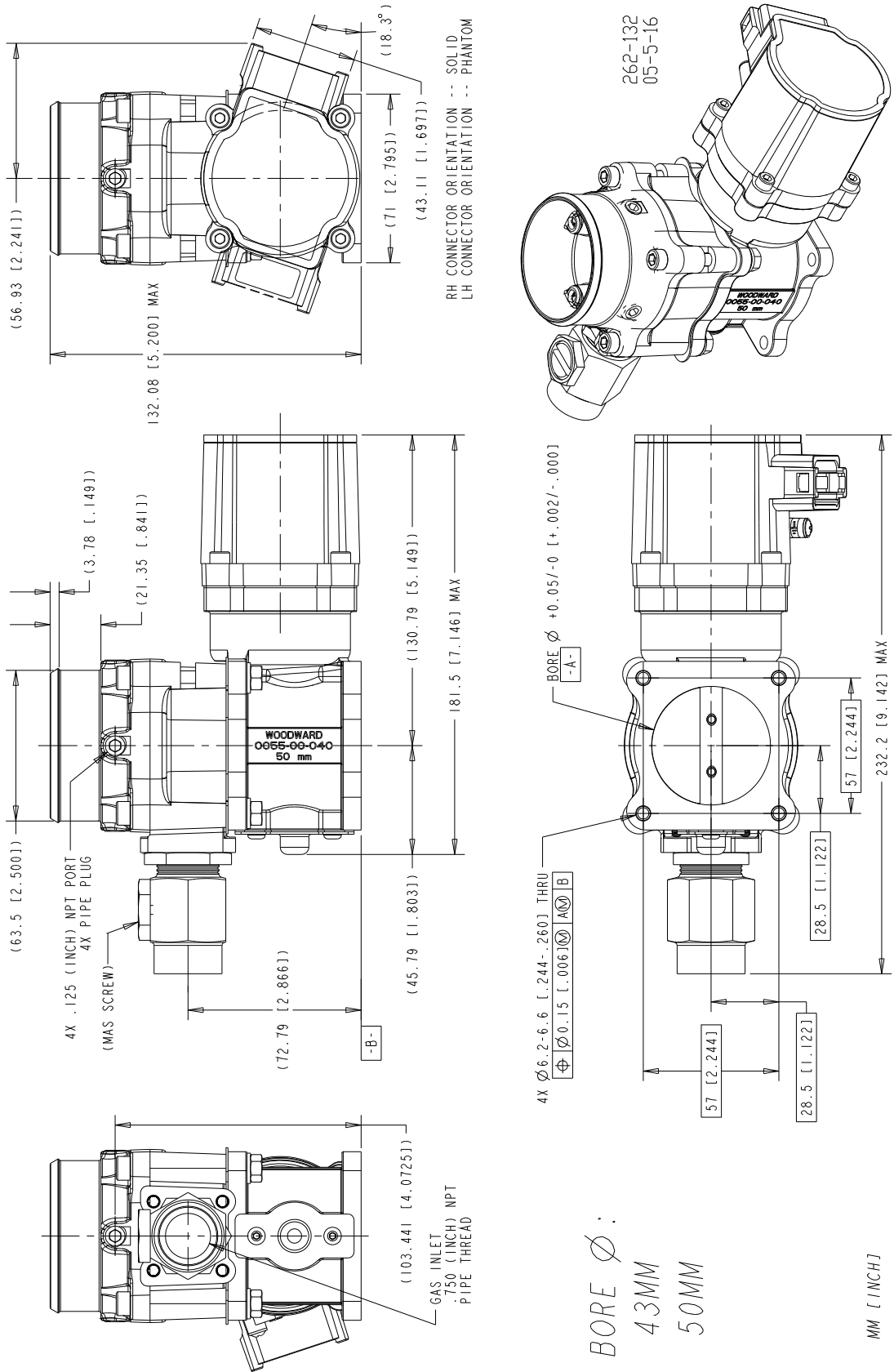

Figure 3-3b. LC-50 Outline Drawing (large bore)

On a turbo-charged engine, the mixer should be located before the turbo compressor. This will yield very high mixture homogeneity as well as allowing the use of a standard ZPR and the ability to use low-pressure gas. To increase safety, some engine manufacturers have mounted flame arrestors between the inlet manifold and the cylinder head, ensuring that a backfire does not lead to an explosion in the inlet manifold, aftercooler, etc., which are filled with ignitable mixture.

The initial settings for the MAS and ZPR are indicated in the table below. These settings should provide the ability to consistently start and run at an approximately stoichiometric air/fuel ratio. The procedure for adjusting these settings for optimum air/fuel ratio is described in the air/fuel ratio tuning section (Chapter 4). The main adjustment screw (MAS) settings are measured from the MAS valve body (not the jam nut) to the exterior end of the MAS screw. The zero-pressure regulator settings are measured from the top of the spring adjustment screw to the top of the spring tower.

For dual-fuel configurations, the standard NG fuel set up should have a tee added between the ZPR and MAS. The side-leg of the tee should then have the MAS and ZPR for the LP fuel. The initial settings for dual-fuel NG and LP are the same as the single-fuel settings below. The final air/fuel ratio adjustments should be done on NG first, then LP, using the procedure in Chapter 4 for each fuel.

MAS and ZPR Initial Settings

ITB Size	Natural Gas	Propane
50 mm	Screw Setting Position (mm)	
MAS	19	16
ZPR	16	14
43 mm		
MAS	17	15
ZPR	16	14
36 mm		
MAS	11	9.5
ZPR	14	14
30 mm		
MAS	11	9
ZPR	14	14
25 mm		
MAS	10	8
ZPR	14	14

LC-50 Applications (Mixer Applications)

After the initial program is configured, the air/fuel ratio should be optimized before extensive engine speed governor tuning is done. Start with low gain values and step slowly through load changes until the air/fuel ratio is tuned.

Initial settings are described in the Hardware Configuration section Chapter 2. These settings should get the gensets up and running for final adjustment with an oxygen sensor or exhaust analyzer.



WARNING

Know in advance how to safely shut off the engine during normal and emergency stop conditions. Shutting off power to the governor does not always guarantee a controlled shutdown; it depends on the final application. Safety needs to be the overriding thought during this procedure.

Air/Fuel Ratio Tuning

1. Insert an oxygen sensor or exhaust gas analyzer into the exhaust stream as directed by the manufacturer of the sensor or analyzer.
2. Start the engine and allow it to warm up for about 15 minutes.
3. Apply 75% to 90% load to the engine.



WARNING The load may need to be applied gradually to avoid underspeed and overspeed conditions.

4. Adjust the MAS to achieve the desired air/fuel ratio. The figures below show the characteristic response of the oxygen sensors and exhaust gas. Clockwise rotation of the MAS will cause the air/fuel ratio to become leaner. Counterclockwise rotation will cause the air/fuel ratio to become richer.

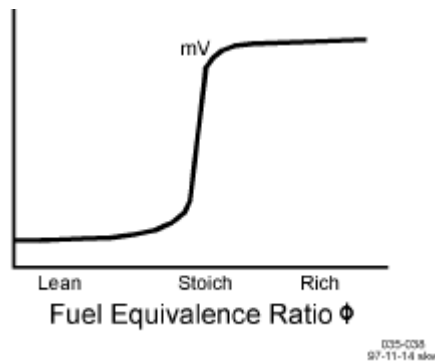

Figure 3-4. Zirconia Oxygen Sensor Response

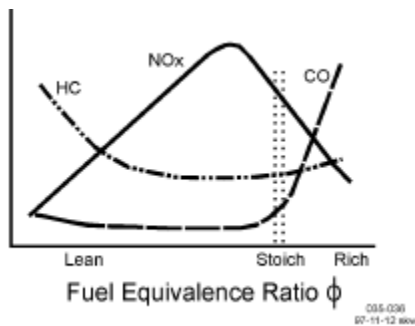

Figure 3-5. Pre-Catalyst Emissions

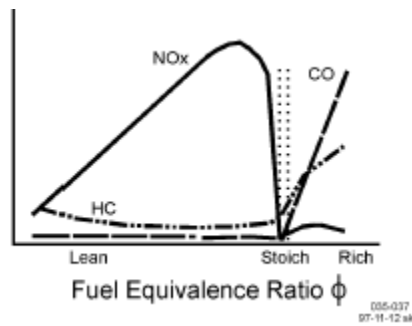

Figure 3-6. Post-Catalyst Emissions

5. The ZPR should then be adjusted at no-load. Clockwise rotation of the screw will cause the mixture to become richer, counterclockwise rotation will cause the mixture to become leaner. When the cover is removed from the ZPR, extra air leakage is introduced into the system. So, a final setting cannot be determined until the ZPR spring tower is covered.
6. One or two more iterations at full load for the MAS and no load for the ZPR should provide the correct air/fuel ratio over the entire operating range.

Chapter 4. Troubleshooting

This chapter presents several broad categories of application failures typically experienced in the field, possible causes, and some tests used to verify the causes. Because the exact failure experienced in the field is the product of the mechanical/electrical failure combined with the control configuration, it is left as the OEM's responsibility to create a more detailed troubleshooting chart for the end user. Ideally, this end-user troubleshooting chart will contain information about mechanical, electrical, engine, and load failures in addition to the possible governor failures. For more detailed information about governor system failure modes and effects, contact Woodward for a copy of the system DFMEA.

The troubleshooting scenarios listed below assume that the application has been engineered and tested thoroughly.

Problem	Possible Cause	Suggested Test/Correction
Engine does not start	Stuck throttle/frozen shaft	Move throttle by hand. Assess smoothness, friction, and return spring force.
Engine starts, runs, but is unstable	Air/fuel ratio not correct	If using LC-50 mixer, MAS, & ZPR, follow air/fuel ratio tuning guidelines in Chapter 4. Otherwise, follow fuel system manufacturer's guidelines.
	Position, Speed, or Process Control is has not been adequately tuned.	See manual 26237, 26250, or 26251 for application setup procedures.

Chapter 5.

Product Support and Service Options

Product Support Options

If you are experiencing problems with the installation, or unsatisfactory performance of a Woodward product, the following options are available:

1. Consult the troubleshooting guide in the manual.
2. Contact the **OE Manufacturer or Packager** of your system.
3. Contact the **Woodward Business Partner** serving your area.
4. Contact Woodward technical assistance via email (EngineHelpDesk@Woodward.com) with detailed information on the product, application, and symptoms. Your email will be forwarded to an appropriate expert on the product and application to respond by telephone or return email.
5. If the issue cannot be resolved, you can select a further course of action to pursue based on the available services listed in this chapter.

OEM or Packager Support: Many Woodward controls and control devices are installed into the equipment system and programmed by an Original Equipment Manufacturer (OEM) or Equipment Packager at their factory. In some cases, the programming is password-protected by the OEM or packager, and they are the best source for product service and support. Warranty service for Woodward products shipped with an equipment system should also be handled through the OEM or Packager. Please review your equipment system documentation for details.

Woodward Business Partner Support: Woodward works with and supports a global network of independent business partners whose mission is to serve the users of Woodward controls, as described here:

- A **Full-Service Distributor** has the primary responsibility for sales, service, system integration solutions, technical desk support, and aftermarket marketing of standard Woodward products within a specific geographic area and market segment.
- An **Authorized Independent Service Facility (AISF)** provides authorized service that includes repairs, repair parts, and warranty service on Woodward's behalf. Service (not new unit sales) is an AISF's primary mission.
- A **Recognized Engine Retrofitter (RER)** is an independent company that does retrofits and upgrades on reciprocating gas engines and dual-fuel conversions, and can provide the full line of Woodward systems and components for the retrofits and overhauls, emission compliance upgrades, long term service contracts, emergency repairs, etc.

A current list of Woodward Business Partners is available at www.woodward.com/directory.

Product Service Options

Depending on the type of product, the following options for servicing Woodward products may be available through your local Full-Service Distributor or the OEM or Packager of the equipment system.

- Replacement/Exchange (24-hour service)
- Flat Rate Repair
- Flat Rate Remanufacture

Replacement/Exchange: Replacement/Exchange is a premium program designed for the user who is in need of immediate service. It allows you to request and receive a like-new replacement unit in minimum time (usually within 24 hours of the request), providing a suitable unit is available at the time of the request, thereby minimizing costly downtime.

This option allows you to call your Full-Service Distributor in the event of an unexpected outage, or in advance of a scheduled outage, to request a replacement control unit. If the unit is available at the time of the call, it can usually be shipped out within 24 hours. You replace your field control unit with the like-new replacement and return the field unit to the Full-Service Distributor.

Flat Rate Repair: Flat Rate Repair is available for many of the standard mechanical products and some of the electronic products in the field. This program offers you repair service for your products with the advantage of knowing in advance what the cost will be.

Flat Rate Remanufacture: Flat Rate Remanufacture is very similar to the Flat Rate Repair option, with the exception that the unit will be returned to you in “like-new” condition. This option is applicable to mechanical products only.

Returning Equipment for Repair

If a control (or any part of an electronic control) is to be returned for repair, please contact your Full-Service Distributor in advance to obtain Return Authorization and shipping instructions.

When shipping the item(s), attach a tag with the following information:

- return number;
- name and location where the control is installed;
- name and phone number of contact person;
- complete Woodward part number(s) and serial number(s);
- description of the problem;
- instructions describing the desired type of repair.

Packing a Control

Use the following materials when returning a complete control:

- protective caps on any connectors;
- antistatic protective bags on all electronic modules;
- packing materials that will not damage the surface of the unit;
- at least 100 mm (4 inches) of tightly packed, industry-approved packing material;
- a packing carton with double walls;
- a strong tape around the outside of the carton for increased strength.

NOTICE

To prevent damage to electronic components caused by improper handling, read and observe the precautions in Woodward manual 82715, *Guide for Handling and Protection of Electronic Controls, Printed Circuit Boards, and Modules*.

Replacement Parts

When ordering replacement parts for controls, include the following information:

- the part number(s) (XXXX-XXXX) that is on the enclosure nameplate;
- the unit serial number, which is also on the nameplate.

Engineering Services

Woodward's Full-Service Distributors offer various Engineering Services for our products. For these services, you can contact the Distributor by telephone or by email.

- Technical Support
- Product Training
- Field Service

Technical Support is available from your equipment system supplier, your local Full-Service Distributor, or from many of Woodward's worldwide locations, depending upon the product and application. This service can assist you with technical questions or problem solving during the normal business hours of the Woodward location you contact.

Product Training is available as standard classes at many Distributor locations. Customized classes are also available, which can be tailored to your needs and held at one of our Distributor locations or at your site. This training, conducted by experienced personnel, will assure that you will be able to maintain system reliability and availability.

Field Service engineering on-site support is available, depending on the product and location, from one of our Full-Service Distributors. The field engineers are experienced both on Woodward products as well as on much of the non-Woodward equipment with which our products interface.

For information on these services, please contact one of the Full-Service Distributors listed at www.woodward.com/directory.

Contacting Woodward's Support Organization

For the name of your nearest Woodward Full-Service Distributor or service facility, please consult our worldwide directory published at www.woodward.com/directory.

You can also contact the Woodward Customer Service Department at one of the following Woodward facilities to obtain the address and phone number of the nearest facility at which you can obtain information and service.

Products Used In Electrical Power Systems

<u>Facility</u> -----	<u>Phone Number</u>
Brazil -----	+55 (19) 3708 4800
China -----	+86 (512) 6762 6727
Germany:	
Kempen----	+49 (0) 21 52 14 51
Stuttgart--	+49 (711) 78954-510
India -----	+91 (129) 4097100
Japan-----	+81 (43) 213-2191
Korea -----	+82 (51) 636-7080
Poland-----	+48 12 295 13 00
United States----	+1 (970) 482-5811

Products Used In Engine Systems

<u>Facility</u> -----	<u>Phone Number</u>
Brazil -----	+55 (19) 3708 4800
China -----	+86 (512) 6762 6727
Germany-----	+49 (711) 78954-510
India -----	+91 (129) 4097100
Japan-----	+81 (43) 213-2191
Korea -----	+82 (51) 636-7080
The Netherlands-	+31 (23) 5661111
United States----	+1 (970) 482-5811

Products Used In Industrial Turbomachinery Systems

<u>Facility</u> -----	<u>Phone Number</u>
Brazil -----	+55 (19) 3708 4800
China -----	+86 (512) 6762 6727
India -----	+91 (129) 4097100
Japan-----	+81 (43) 213-2191
Korea -----	+82 (51) 636-7080
The Netherlands-	+31 (23) 5661111
Poland-----	+48 12 295 13 00
United States----	+1 (970) 482-5811

For the most current product support and contact information, please visit our website directory at www.woodward.com/directory.

Technical Assistance

If you need to contact technical assistance, you will need to provide the following information. Please write it down here before contacting the Engine OEM, the Packager, a Woodward Business Partner, or the Woodward factory:

General

Your Name _____

Site Location _____

Phone Number _____

Fax Number _____

Prime Mover Information

Manufacturer _____

Engine Model Number _____

Number of Cylinders _____

Type of Fuel (gas, gaseous, diesel,
dual-fuel, etc.) _____

Power Output Rating _____

Application (power generation, marine,
etc.) _____

Control/Governor Information

Control/Governor #1

Woodward Part Number & Rev. Letter _____

Control Description or Governor Type _____

Serial Number _____

Control/Governor #2

Woodward Part Number & Rev. Letter _____

Control Description or Governor Type _____

Serial Number _____

Control/Governor #3

Woodward Part Number & Rev. Letter _____

Control Description or Governor Type _____

Serial Number _____

Symptoms

Description _____

If you have an electronic or programmable control, please have the adjustment setting positions or the menu settings written down and with you at the time of the call.

L-Series ITB Specifications

	Specifications
Mass/Weight	425 g (15 oz)
	Control Characteristics
Engine Type	2-cycle or 4-cycle gasoline, diesel, or gaseous fuel
Actuator Torque	High-efficiency torque motor delivers 0.34 N·m (0.25 lb-ft) (standard model) over 60° travel range to operate fuel or air control
	Environment
Ambient	
Operating Temperature	−40 to +105 °C (−40 to +221 °F)
Storage Temperature	−40 to +125 °C (−40 to +257 °F)
Humidity	US MIL-STD 810E, Method 507.3, Procedure III
Salt Spray	US MIL-STD 810E, Method 509.3, Procedure I
Shock	MS1-40G 11ms sawtooth
Vibration	Random: 0.3 G ² /Hz , 10–2000 Hz (22.1Grms) 3 h/axis Sine: 5 G 2.5 mm peak-to-peak, 5–2000 Hz, 3 h/axis, 90 min dwells, 1 octave/min
Drop	SAE J1211, Paragraph 4.8.3 (modified)
Thermal Shock	SAE J1455, Paragraph 4.1.3.2
Ingress Protection	IP56 per EN60529
Inlet Pressure	Sealed shaft bearings: 2 bar (29 psi) gage Standard shaft bearings: 0.068 bar (1 psi) gage

Regulatory Compliance

Note—Refer to L-Series control manual (26237, 26250 or 26251) for actuator compliance

Compliance with the following European Directives or standards does not qualify this product for application of the CE Marking:

Pressure Equipment Directive: Exempt per Article 1-3.10

Reliability and Quality Goals

The L-Series control system has a reliability target of 17 500 hours MTBF. It also has a quality goal of less than 25 PPM when measuring out-of-the-box defects. This quality goal is a target based on continuous improvement.

Appendix. Acronyms/Abbreviations

A/F	air/fuel ratio
ITB	integrated throttle body
LC-50	Woodward system that incorporates L-Series with an ITB and mixer
MAP	manifold air pressure
MAS	main adjustment screw
OEM	original equipment manufacturer
stoichiometric	chemically balanced air/fuel ratio
ZPR	zero pressure regulator

DECLARATION OF CONFORMITY

According to EN 45014

Manufacturer's Name: WOODWARD GOVERNOR COMPANY (WGC)
Industrial Controls Group

Manufacturer's Address: 1000 E. Drake Rd.
Fort Collins, CO, USA, 80525

Model Name(s)/Number(s): L-Series
8404-xxxx and similar

Conformance to Directive(s): 89/336/EEC COUNCIL DIRECTIVE of 03 May 1989 on the approximation of the laws of the Member States relating to electromagnetic compatibility and all applicable amendments.

Units marked and conforming to ATEX conform to Directive: 94/9/EC COUNCIL DIRECTIVE of 23 March 1994 on the approximation of the laws of the Member States concerning equipment and protective systems intended for use in potentially explosive atmospheres

Markings on units conforming to ATEX: II 3 G, EEx nA II T3X, IP56

Applicable Standards: EN61000-6-4, (2001): EMC Part 6-4: Generic Standards - Emissions for Industrial Environments
EN61000-6-2, (2001): EMC Part 6-2: Generic Standards - Immunity for Industrial Environments
EN60079-15, (2003) Electrical apparatus for explosive gas atmospheres – Part 15: Type of protection 'n'

We, the undersigned, hereby declare that the equipment specified above conforms to the above Directive(s).

MANUFACTURER

Signature

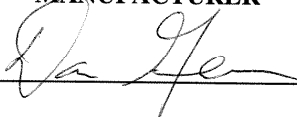

Dan Gear

Full Name

Engineering Manager

Position

WGC, Fort Collins, CO, USA

Place

Date

2/17/06

Declaration of Incorporation

Woodward Governor Company
1000 E. Drake Road
Fort Collins, Colorado 80525
United States of America

Product: L-Series Actuator
Part Number: 6300-1005 and similar

The undersigned hereby declares, on behalf of Woodward Governor Company of Loveland and Fort Collins, Colorado, that the above-referenced product is in conformity with the following EU Directives as they apply to a component:

98/37/EEC (Machinery)

This product is intended to be put into service only upon incorporation into an apparatus/system that itself will meet the requirements of the above Directives and bears the CE mark.

MANUFACTURER

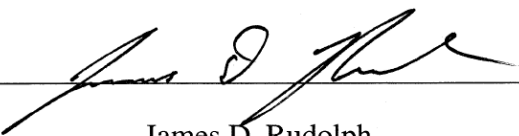
Signature	
Full Name	James D. Rudolph
Position	Engineering Manager
Place	WGC, Fort Collins, CO, USA
Date	11/13/07

We appreciate your comments about the content of our publications.

Send comments to: icinfo@woodward.com

Please reference publication **26249E**.



B26249:E



PO Box 1519, Fort Collins CO 80522-1519, USA
1000 East Drake Road, Fort Collins CO 80525, USA
Phone +1 (970) 482-5811 • Fax +1 (970) 498-3058

Email and Website—www.woodward.com

Woodward has company-owned plants, subsidiaries, and branches,
as well as authorized distributors and other authorized service and sales facilities throughout the world.

Complete address / phone / fax / email information for all locations is available on our website.