



Installation and Operation Manual



L-Series Integrated Speed Control

Manual 26250 (Revision J)

IMPORTANT



This is the safety alert symbol. It is used to alert you to potential personal injury hazards. Obey all safety messages that follow this symbol to avoid possible injury or death.

DEFINITIONS

- **DANGER**—Indicates a hazardous situation which, if not avoided, will result in death or serious injury.
- **WARNING**—Indicates a hazardous situation which, if not avoided, could result in death or serious injury.
- **CAUTION**—Indicates a hazardous situation which, if not avoided, could result in minor or moderate injury.
- **NOTICE**—Indicates a hazard that could result in property damage only (including damage to the control).
- **IMPORTANT**—Designates an operating tip or maintenance suggestion.

WARNING

The engine, turbine, or other type of prime mover should be equipped with an overspeed shutdown device to protect against runaway or damage to the prime mover with possible personal injury, loss of life, or property damage.

The overspeed shutdown device must be totally independent of the prime mover control system. An overtemperature or overpressure shutdown device may also be needed for safety, as appropriate.



Read this entire manual and all other publications pertaining to the work to be performed before installing, operating, or servicing this equipment. Practice all plant and safety instructions and precautions. Failure to follow instructions can cause personal injury and/or property damage.



This publication may have been revised or updated since this copy was produced. To verify that you have the latest revision, be sure to check the Woodward website:

www.woodward.com/pubs/current.pdf

The revision level is shown at the bottom of the front cover after the publication number. The latest version of most publications is available at:

www.woodward.com/publications

If your publication is not there, please contact your customer service representative to get the latest copy.



Any unauthorized modifications to or use of this equipment outside its specified mechanical, electrical, or other operating limits may cause personal injury and/or property damage, including damage to the equipment. Any such unauthorized modifications: (i) constitute "misuse" and/or "negligence" within the meaning of the product warranty thereby excluding warranty coverage for any resulting damage, and (ii) invalidate product certifications or listings.

NOTICE

To prevent damage to a control system that uses an alternator or battery-charging device, make sure the charging device is turned off before disconnecting the battery from the system.

NOTICE

To prevent damage to electronic components caused by improper handling, read and observe the precautions in Woodward manual 82715, *Guide for Handling and Protection of Electronic Controls, Printed Circuit Boards, and Modules*.

Revisions—Text changes are indicated by a black line alongside the text.

Woodward Governor Company reserves the right to update any portion of this publication at any time. Information provided by Woodward Governor Company is believed to be correct and reliable. However, no responsibility is assumed by Woodward Governor Company unless otherwise expressly undertaken.

© Woodward 2004
All Rights Reserved

Contents

REGULATORY COMPLIANCE	V
ELECTROSTATIC DISCHARGE AWARENESS	VI
CHAPTER 1. GENERAL INFORMATION.....	1
Purpose and Scope	1
How to Use This Manual	1
Intended Applications	1
Introduction	2
Basic Control Options.....	3
Programmable Features.....	3
Service Tool Software	4
CHAPTER 2. MECHANICAL INSTALLATION	5
Introduction	5
General Installation, Operation Notes and Requirements.....	5
Unpacking.....	6
Mechanical Installation	6
CHAPTER 3. ELECTRICAL INSTALLATION.....	15
Introduction	15
Shielded Wiring	15
Description of Electrical I/O	18
CHAPTER 4. DESCRIPTION OF OPERATION	28
General.....	28
System Operation	29
Starting the Engine	29
Control Features Description.....	29
Speed Control Functions	30
Speed Control Dynamics.....	37
Start Fuel Limiting.....	39
Runtime Fuel Limiting.....	40
Temperature Sensing	42
Current Limiting based on Temperature.....	42
Control Modes	43
Fault Detection and Annunciation	44
Faults.....	44
CHAPTER 5. SERVICE TOOL.....	48
Introduction	48
Description.....	48
Getting Started	50
Monitoring the Driver	51
CHAPTER 6. CONFIGURATION	59
Overview.....	59
Configuration Parameters.....	60
Load Configuration File to Control.....	84
Configuration Checks	85

Contents

CHAPTER 7. SETUP AND TUNING	88
Introduction.....	88
Tuning the Speed PID.....	88
Editing of Configuration Settings.....	89
Tuning the Position PID.....	91
Position Calibration and Verification.....	93
Calibration Sequence Overview.....	93
Position Verification.....	94
CHAPTER 8. TROUBLESHOOTING	98
Introduction.....	98
General System Troubleshooting Guide.....	99
Engine/Generator Troubleshooting.....	99
Troubleshooting Diagnostic Fault Flags.....	103
Electrical Troubleshooting Guide.....	107
CHAPTER 9. SERVICE OPTIONS	109
Product Service Options.....	109
Woodward Factory Servicing Options.....	110
Returning Equipment for Repair.....	111
Replacement Parts.....	111
Engineering Services.....	112
How to Contact Woodward.....	112
Technical Assistance.....	113
APPENDIX A. ACRONYMS/ABBREVIATIONS	114
APPENDIX B. L-SERIES CONTROL SPECIFICATIONS	115
DECLARATIONS	120

Illustrations and Tables

Figure 2-1. Linkage Design Examples	8
Figure 2-2. L-Series Outline Drawing	10
Figure 2-3. L-Series Cover Types	11
Figure 2-4a. L-Series Shaft Types	12
Figure 2-4b. L-Series Shaft Types	13
Figure 2-4c. L-Series Shaft Types.....	14
Figure 3-1a. Typical L-Series Speed Control Application Wiring	17
Figure 3-1b. L-Series Speed Control Connector Pin Arrangement.....	18
Figure 3-2. Correct and Incorrect Wiring to Power Supply.....	19
Figure 3-3. MPU Speed Sensing Input.....	20
Figure 3-4. Proximity Probe Speed Sensing Input	21
Figure 3-5. Ignition Speed Sensing Input.....	21
Figure 3-6. TPS Output	22
Figure 3-7. Relay Driver Output	23
Figure 3-8. Typical AUX Input Usage.....	25
Figure 3-9. Ground Junction Point	27
Figure 4-1 Overview of L-Series Inputs/Outputs	30
Figure 4-2 Speed Setpoint Actions and Rates	31
Figure 4-3. 5% Droop Example	35
Figure 4-4 Remote Speed Setpoint.....	36
Figure 4-5. Dual Gain Settings	38
Figure 4-6. Single Start Fuel Limit.....	39
Figure 4-7. Dual Start Fuel Limiters	40
Figure 4-8. Boost (External) Fuel Limit Curve.....	41
Figure 4-9. Runtime Fuel Limit Curve	42
Figure 5-1. Example Service Tool Screen.....	48
Figure 5-2a. Programming Harness Connections.....	49
Figure 5-2b. Programming Harness Wiring.....	50
Figure 5-3a. Service Tool—Overview Tab	53
Figure 5-3b. Service Tool—Overview Tab (5418-2193 software only)	53
Figure 5-4. Service Tool—Alarms Tab.....	55
Figure 5-5. Service Tool—Shutdowns Tab	56
Figure 5-6. Service Tool—Internal Shutdowns Tab	56
Figure 5-7. Service Tool—Simulated I/O Tab	57
Figure 5-8. Service Tool—Identification Tab	58
Figure 6-1. Configuration Selection Options	60
Figure 6-2. Configuration Editor—OVERVIEW TAB	61
Figure 6-3. Configuration Editor—SETPOINT TAB	63
Figure 6-4. Configuration Editor—CONTROL TAB.....	65
Figure 6-5. Configuration Editor—Modifiers Tab.....	69
Figure 6-6a. Configuration Editor—Fuel Limiting Tab (5418-1680 and -2226 software versions).....	71
Figure 6-6b. Configuration Editor—Fuel Limiting Tab (5418-2193 software only)	72
Figure 6-6c. Configuration Editor—Fuel Limiting Tab (5418-2193 software only)	72
Figure 6-7. Configuration Editor—Dynamics Tab	75
Figure 6-8. Configuration Editor—Discrete I/O Tab	77
Figure 6-9. Configuration Editor—Alarm/Shutdown Tab.....	80
Figure 6-10. Configuration Editor—Security Tab	82
Figure 6-11. Security Tab Set Password Pop-up.....	83
Figure 6-12. Password Entry Prompt	83
Figure 6-13. Configuration Loading.....	84
Figure 6-14. Direct Load of Configuration File	84

Illustrations and Tables

Figure 7-1. Service Tool—Speed Dynamics	89
Figure 7-2a. Edit Configuration Settings Menu (5418-2193 software only)	90
Figure 7-2b. Speed Input Window (5418-1680 and -2226 software versions).....	90
Figure 7-2c. Configuration Settings Window (5418-2193 software only)	91
Figure 7-3. Service Tool—PID Tuning Window.....	92
Figure 7-4. Service Tool—PID Tuning Properties Window	92
Figure 7-5. Service Tool—Manual Position Calibration selection	93
Figure 7-6. Service Tool—Verify Position Calibration	94
Figure 7-7. Service Tool—Manual Position Calibration.....	95
Figure 7-8. Service Tool—Manual Position Calibration Settings	96
Figure 7-9. Service Tool—Auto Position Calibration	97
Figure B-1. Bode Plot of L-Series Response	119

Regulatory Compliance

European Compliance for CE Marking:

These listings are limited only to those units bearing the CE Marking:

EMC Directive: Declared to 89/336/EEC COUNCIL DIRECTIVE of 03 May 1989 on the approximation of the laws of the Member States relating to electromagnetic compatibility.

These listings are limited only to those units bearing the ATEX markings as well as the CE Mark:

ATEX – Potentially Explosive Atmospheres Directive: Declared to 94/9/EC COUNCIL DIRECTIVE of 23 March 1994 on the approximation of the laws of the Member States concerning equipment and protective systems intended for use in potentially explosive atmospheres.
Zone 2, Category 3, Group II G, EEx nA II T3 X
–40 °C ≤ Tamb ≤ +105 °C, IP56

Special Condition for Safe Use: *The installer of the L-series must take responsibility for meeting Sub-Clause 26.3.3.1 of EN60079-15:2003 regarding impact testing. The actuator by itself does not meet this requirement and therefore must be sufficiently protected when installed. See Chapter 2, Mechanical Installation, for more details.*

Other European and International Compliance:

Compliance with the following European Directives or standards does not qualify this product for application of the CE Marking:

Machinery Directive: Compliant as a component with 98/37/EC COUNCIL DIRECTIVE of 23 July 1998 on the approximation of the laws of the Member States relating to machinery.

Pressure Equipment Directive: Exempt per Article 1-3.10

North American Compliance:

These listings are limited only to those units bearing the CSA identification

CSA: CSA Certified for Class I, Division 2, Groups A, B, C, & D, T3C at 105 °C Ambient for use in Canada and the United States. Certificate 1380416

This product is certified as a component for use in other equipment. The final combination is subject to acceptance by the authority having jurisdiction.

Wiring must be in accordance with North American Class I, Division 2 or European Zone 2, Category 3 wiring methods as applicable, and in accordance with the authority having jurisdiction.

Field wiring must be suitable for at least 105 °C.

Connect ground terminal to earth ground.

The actuator should be protected from exposure to sunlight and rain.

WARNING

EXPLOSION HAZARD—Do not connect or disconnect while circuit is live unless area is known to be non-hazardous.

Substitution of components may impair suitability for Class I, Division 2 or Zone 2 applications.

Do not clean equipment unless power has been switched off or the area is known to be non-hazardous.

AVERTISSEMENT

RISQUE D'EXPLOSION—Ne pas raccorder ni débrancher tant que l'installation est sous tension, sauf en cas l'ambiance est décidément non dangereuse.

La substitution de composants peut rendre ce matériel inacceptable pour les emplacements de Classe I, applications Division 2 ou Zone 2.

Electrostatic Discharge Awareness

All electronic equipment is static-sensitive, some components more than others. To protect these components from static damage, you must take special precautions to minimize or eliminate electrostatic discharges.

Follow these precautions when working with or near the control.

1. Before doing maintenance on the electronic control, discharge the static electricity on your body to ground by touching and holding a grounded metal object (pipes, cabinets, equipment, etc.).
2. Avoid the build-up of static electricity on your body by not wearing clothing made of synthetic materials. Wear cotton or cotton-blend materials as much as possible because these do not store static electric charges as much as synthetics.
3. Keep plastic, vinyl, and Styrofoam materials (such as plastic or Styrofoam cups, cup holders, cigarette packages, cellophane wrappers, vinyl books or folders, plastic bottles, and plastic ash trays) away from the control, the modules, and the work area as much as possible.
4. Do not touch the electrical conductors, the connectors, or the components with conductive devices or with your hands.

NOTICE

To prevent damage to electronic components caused by improper handling, read and observe the precautions in Woodward manual 82715, *Guide for Handling and Protection of Electronic Controls, Printed Circuit Boards, and Modules*.

Chapter 1.

General Information

Purpose and Scope

The purpose of this manual is to provide the necessary background information for applying the L-Series integrated speed control to diesel and gas/gasoline reciprocating engines. Topics covered include mechanical installation, electrical wiring, software programming, and troubleshooting. While this manual is primarily targeted at OEM customers, OEMs themselves may find it useful to copy some of the information from this manual into their application user manuals.

This manual does not contain instructions for the operation of the complete engine system. For engine or plant operating instructions, contact the plant-equipment manufacturer.

This version of the manual applies to all L-Series Speed Control models with software 5418-1680B, 5418-2193, and 5418-2226 or newer. The software version can be identified on the Identification tab of the Service Tool.

How to Use This Manual

The following summarizes how to install an L-Series speed control into a new or existing system:

- Unbox and inspect the hardware.
- Mount and wire the hardware following the procedures and recommendations in Chapters 2–3.
- Configure the control using the Service Tool (Chapter 6). Not required if pre-configured by OEM.
- Stroke the valve and verify/tune dynamics and functionality (Chapter 7). Not required if set up by OEM.
- Troubleshooting guidelines are provided in Chapter 8.
- Specifications are provided in Appendix B.

Intended Applications

The L-Series speed control is a suitable replacement for mechanical systems that need more flexibility in control strategy, like dual dynamics, idle rated dynamics, and gain curves. The L-Series control is designed for industrial applications ranging from generators and mechanical drives to pumps and compressors.

Key environmental characteristics of these applications include extended industrial operating temperatures (–40 to +105 °C/–40 to +221 °F), industrial EMC requirements, electrical transients, and lower operating voltages (12/24 V).

Introduction

The Woodward L-Series combines the L-Series electric actuator with integrated speed control software to control the speed of a diesel or gaseous engine. The L-Series is a microprocessor-based control that is incorporated into the actuator, creating a single integrated package. This eliminates the need for an additional driver box and speed control box.

The control uses state-of-the-art speed sensing and control algorithms. The L-Series also performs comprehensive diagnostics for easy troubleshooting. It can be configured and tuned using the L-Series Service Tool.

The L-Series provides a building block approach to total engine management. The modular bi-directional actuator design easily attaches to fuel pumps, mixers, or throttle bodies. For information on Woodward throttle body applications, refer to manual 26249 (ITB and LC-50).

Woodward also offers L-Series actuator versions for Position Control and Process Control, like Air/Fuel Ratio control, applications. Refer to manuals 26237 (Position Control) or 26251 (Process Control).

The L-Series speed control accepts a speed signal (ignition or MPU), compares this to the speed setpoint, and drives the 0–60 degree output shaft to the commanded position based on an internal shaft position sensor. The high-efficiency torque motor delivers 0.34 N·m (0.25 lb-ft) nominally over 60° travel range to operate fuel or air control devices. See the specifications (Appendix B) for more details.

There are 4 AUX inputs for I/O functions, configurable as digital inputs, analog inputs, or RS-232 Service Tool communications. The functions available for AUX input configuration are:

- Isochronous Loadsharing analog input
- Remote Speed Setpoint analog input
- MAP/Boost Fuel limit analog input
- Rated 1 / Rated 2 (50/60 Hz) digital input
- Raise Speed Setpoint digital input
- Lower Speed Setpoint digital input
- Isoch/Droop digital input
- Idle/Rated digital input
- Alternate Dynamics digital input
- Run Enable digital input

For status purposes, a relay driver output is available on the L-Series control which changes state whenever a fault or error condition is experienced by the L-Series control.

If the system so requires, the L-Series provides a direct position output signal in the form of a dc voltage. The throttle position (TPS) output represents full counterclockwise (ccw) to clockwise (cw) rotation of the actuator shaft, and thus gives the operator an external position indication after installation and while the unit is operating.

WARNING

When included with an ITB, the actuator depends solely on the return spring inside the throttle body assembly to drive toward minimum fuel when not powered. Therefore other positive shutdown devices like fuel shut-off solenoids are recommended to ensure shutdown on loss of signal to the control system. Also, separate overspeed trip devices are always mandatory.

Basic Control Options

Position control with software support for:

- cw / ccw (clockwise/counterclockwise) direction control
- Field calibration options

Speed control with software selectable:

- Speed setpoints
- Dynamics
- Fuel Limiting
- Start / Stop behavior
- Input/Output definitions

**WARNING**

The actuator must be properly set up using the L-Series Service Tool prior to starting the prime mover.

IMPORTANT

The Service Tool is not included, but can be downloaded from the Woodward Internet website (www.woodward.com/software).

Programmable Features

Control setup and tuning is accomplished through the use of a PC (personal computer), Woodward Service Tool software, and a programming harness. The features identified below are described in Chapters 2 and 4. Briefly, the programmable features include:

- Speed Signal Setup Parameters
- General Setup Parameters
 - Fail Direction (ccw or cw)
 - Min Position Direction (ccw or cw)
- Valve Position Control Parameters
- Speed Setpoint Setup Parameters
 - Functionality Settings
 - Idle/Rated 1/Rated 2 Speed Settings
 - Acceleration and Deceleration Rates
 - Droop / Isoch
 - Biasing Behavior and Rates
- Speed Control Setup Parameters
 - Behavior
 - Start Speed settings and Rates
 - Engine Stopping Settings
 - Speed Error Detection Settings
 - Dynamics Settings
- Fuel Limiting
 - Behavior
 - Settings and Rates
- Discrete Output Settings
- Discrete Input Settings
- Fault Settings
- Security Settings

Service Tool Software

The L-Series Service Tool software is a Microsoft Windows® based GUI (graphic user interface). The Service Tool Software is compatible with Windows NT/2000/XP and gives the OEM the ability to:

- Configure product settings based on application requirements
- Tune the control with the engine running during application development
- Create configuration files for downloading into multiple controls
- Download configuration files
- Extract and view fault codes for field diagnosis
- Update control dynamics during field service
- Calibrate the control for user stops

In addition, the Service Tool can be configured to incorporate security to control access to and protect application settings where needed.

Detailed descriptions of software features and installation are available in Chapters 4–7.

Chapter 2. Mechanical Installation

Introduction

This chapter provides instructions on how to mount and connect the L-Series control into a system. Hardware dimensions are provided for mounting the device to a specific application.

WARNING

EXPLOSION HAZARD—Do not connect or disconnect while circuit is live unless area is known to be non-hazardous.

Substitution of components may impair suitability for Class I, Division 2 or Zone 2 applications.

WARNING

External fire protection is not provided in the scope of this product. It is the responsibility of the user to satisfy any applicable requirements for their system.

WARNING

Due to the hazardous location listings associated with this product, proper wire type and wiring practices are critical to operation.

CAUTION

Due to typical noise levels in turbine or engine environments, hearing protection should be worn when working on or around the L-Series.

CAUTION

The surface of this product can become hot enough or cold enough to be a hazard. Use protective gear for product handling in these circumstances. Temperature ratings are included in the specification section of this manual.

NOTICE

Do not connect any cable grounds to “instrument ground”, “control ground”, or any non-earth ground system. Make all required electrical connections based on the wiring diagrams (Figure 3-5).

General Installation, Operation Notes and Requirements

WARNING

Use of an independent device for positive shutdown, such as a fuel shut-off valve, is highly recommended. Failure to comply with this recommendation can cause personal injury and/or property damage.

Use of an external spring to return to minimum fuel is highly recommended. Failure to comply with this recommendation can cause personal injury and/or property damage.

Use of a predicted min-fuel-shutdown procedure is highly recommended. Failure to comply with this recommendation can cause personal injury and/or property damage.

Unpacking

Be careful when unpacking the actuator. Check the unit for signs of damage, such as bent or dented panels, scratches, and loose or broken parts. Notify the shipper and Woodward if damage is found.

Mechanical Installation

Mounting Location

IMPORTANT

To meet ATEX Hazardous Location requirements, the installer of the L-series must take responsibility for meeting Sub-Clause 26.3.3.1 of EN60079-15:2003 regarding impact testing. The actuator by itself does not meet this requirement and therefore must be sufficiently protected when installed. According to EN60079-15, the protection must be such that a 1 kg mass, fitted with an impact head in the form of a hemisphere of 25 mm diameter, can be dropped vertically from a height of 0.7 meter, and not cause significant damage to the actuator.

Locate the L-Series control a distance from sources of extreme radiant heat, such as exhaust manifolds or turbochargers. The operating temperature range of the control is -40 to $+105$ °C (-40 to $+221$ °F). In spark-ignited applications, make sure the L-Series is located away from the ignition coil, and that harness wires are not routed next to the spark plug wires.

As shown in the specifications, the L-Series control has been designed for and verified to a given accelerated life vibration test level at the mounting surface of the actuator. The user should be aware that in any application, bracket design can significantly change the vibration levels at the actuator. Therefore, every effort should be made to make the bracket as stiff as possible so that engine vibrations are not amplified, creating an even more severe environment at the actuator. Additionally, when possible, orienting the actuator shaft parallel to the crankshaft of the engine will often reduce the vibration load on the actuator's rotor system in reciprocating engine applications.

Mounting the L-Series Actuator with an ITB

Typical mounting of a L-Series actuator with an ITB is accomplished by fastening the throttle to the inlet and outlet pipes. Ensure that the pipes can support the weight of the L-Series actuator and the throttle body.

Output Shaft

The L-Series actuator has 58 – 62 ° of available travel. The max fuel direction of this travel is software configurable in the clockwise or counterclockwise direction through the Service Tool.

Mounting Orientation

While it is not a requirement, it is good practice to orient the connector feature on the control in a horizontal or downward orientation to minimize fluid accumulation between the enclosure and the mating connector's gasket.

Actuator Configuration

The L-Series actuator utilizes a 2.0" (50.8 mm) square mounting bolt pattern and is intended to fit within an envelope of 2.618 x 2.618 x 2.540" (66.50 x 66.50 x 64.52 mm) with the short dimension along the shaft axis. Two shaft seal configurations are available, an internal lip seal and an external lip seal with spring backup (Figure 2-3). In addition, six independent output shaft configurations are available (Figure 2-4). Consult Woodward applications engineering for the application appropriate seal and shaft configuration.

Mounting Hardware

Use M5 or #10 fasteners torqued to 4 N·m (35 lb-in) to attach the L-Series control to the mounting bracket. The bracket and attaching hardware must be designed to hold the weight and to withstand the vibration associated with prime mover mounting. Use the appropriate fasteners for securing the mounting bracket to the engine.

Mechanical (Fuel Position) Stops

Diesel Stops—Diesel installations will generally use the fuel system minimum and maximum position stops. Diesel engine applications are normally designed to provide the minimum and maximum stops without binding. The actuator's stops must not prevent the actuator from driving the fuel linkage to the minimum and maximum positions. The linkage should be designed to use as much actuator travel as possible, without preventing minimum and maximum fuel positions.

Gas Engine Stops—Butterfly valves in carburetors will often bind if rotated too far toward minimum or maximum. For this reason, hard stops in the throttle body or associated linkage should be used at both minimum and maximum positions. The engine must always shut down when the actuator is at the minimum stop.

Linkage

Proper design and installation of the linkage from the actuator to the engine is necessary for the unit to provide the best control possible. The characteristics of the engine fuel system and the control dictate the linkage design. Most diesel fuel pumps have a linear relationship between metering valve or fuel rack position and the amount of fuel delivered to the engine. Throttle bodies have a non-linear relationship between throttle angle and air/fuel flow.

Because the L-Series is a linear control, a linkage designed for diesel applications tends to maintain a 1:1 relationship between actuator shaft angle and rack position throughout the range of travel. A linkage designed for gas or gasoline applications tends to start with a 3:1 relationship transitioning to a 1:3 relationship between actuator shaft angle and throttle angle throughout the range of travel. This non-linear linkage design essentially compensates the throttle body so the air/fuel flow looks linear from the control's perspective. Woodward recommends that linkages use approximately 40 degrees of actuator shaft rotation, centered in the full 60-degree range. This maximizes the resolution of the actuator control loop, making the engine easier to govern. Refer to Figure 2-1 for examples of typical linkage designs.

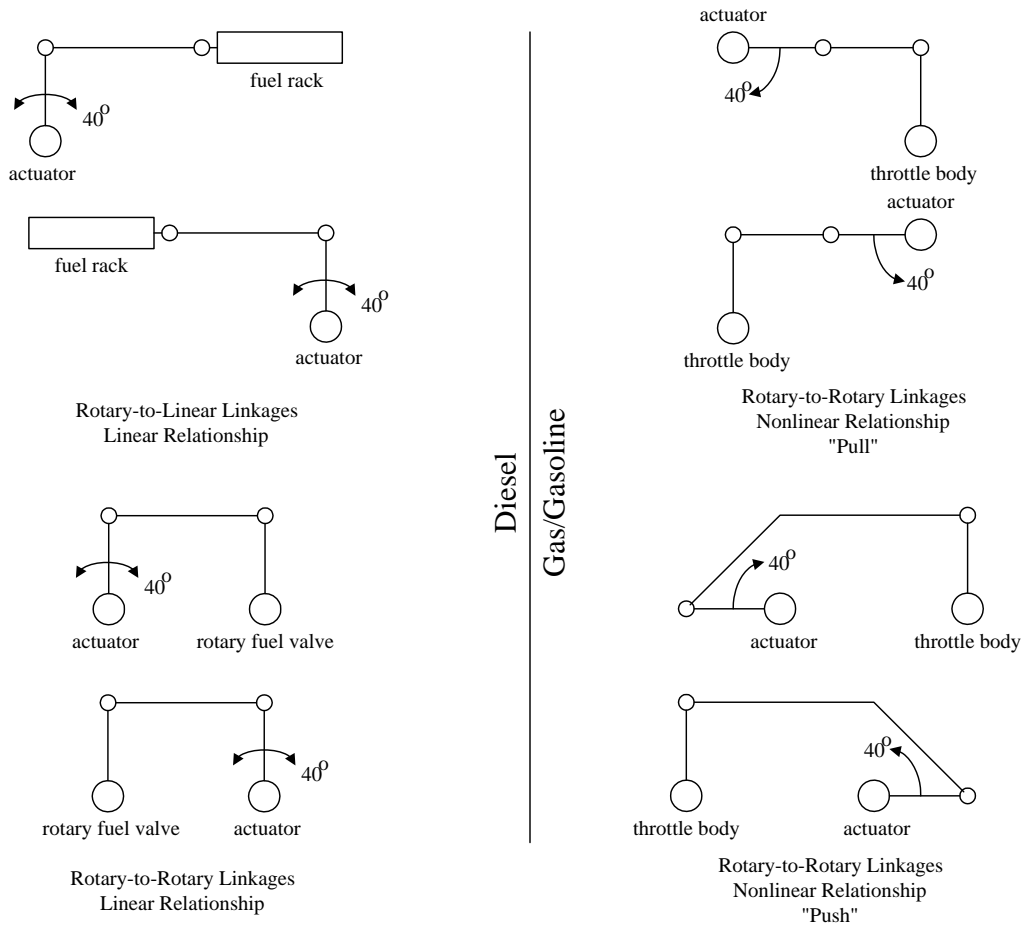

Figure 2-1. Linkage Design Examples

To increase the amount of actuator rotation, move the rod end closer to the actuator shaft or farther away from the shaft controlling the fuel flow. To decrease the amount of actuator rotation, move the rod end farther from the actuator shaft or closer to the throttle shaft.

Once installed, manually stroke the fuel-control linkage from stop to stop as if the actuator were moving it. The linkage must move freely, without friction and backlash. Lubricate or replace worn linkage or fuel control parts as required.

Always make sure the fuel delivery device (fuel pump or throttle body) has a return spring that pulls towards minimum fuel when no power is applied to the control. Size the return spring so that the actuator output shaft sees no more than 0.07 N·m (0.05 lb-ft) of torque at maximum loading conditions.

In addition to a return spring, always make sure the application includes a secondary overspeed protection device as a backup to the main governor's overspeed detection function.

NOTICE

The actuator's maximum slew rate can place stress on the fuel system stops and on the linkage between the actuator and the fuel system. The maximum actuator speed is 1100 degrees per second in both increase and decrease fuel directions under normal operating conditions. Exceeding the control input voltage requirements may cause a unit shutdown in which the actuator speed may exceed 3500 degrees per second.

The Mass Moment of Inertia (MMOI) for the L-Series actuators is 1.48 E-5 kg-m^2 (1.57E-3 lb-in-s^2). External fuel system stops should be used and must be adequate to absorb the actuator MMOI in addition to the linkage inertia without damage.

Use of good rod-end connectors with as little free play as possible is essential. Select rod ends that will remain tight and wear well during the nearly constant movement associated with precise speed control. The link connecting the actuator lever to the fuel-control lever must be short and stiff enough to prevent flexing while the engine is running.

Typically, in a linkage system, there may be links and levers which are supported by customer-supplied bearings. Additionally, there will typically be a section of the linkage where the mass is supported fully by the actuator output shaft. Minimizing the mass the actuator is required to support is essential in that excessive mass or vibration levels may damage the actuator's rotor system and shorten the life of the actuator.

NOTES:

1. MOUNTING HARDWARE TO BE SOCKET HEAD CAP SCREWS -- #10(.190)-24, M5, OR EQUIVALENT. NO WASHERS TO BE USED. RECOMMENDED SCREW TORQUE = 35 IN-LB [4 N-M].
2. FOR BRACKET-MOUNT APPLICATION, A BRACKET OUT-OF-FLATNESS OF .010 [0.25] MAXIMUM IS RECOMMENDED.
3. FOR CONNECTOR INFORMATION, REFER TO CONNECTOR TABLE AND APPROPRIATE WIRING DIAGRAM.
4. USE OF INTERNAL ACTUATOR STOPS IN APPLICATION NOT RECOMMENDED. TORQUE AGAINST STOPS NOT TO EXCEED 200 IN-OZ.
5. DIMENSIONS ARE SHOWN IN INCHES [MM].
6. DETAILS SHOWN HERE ARE COMMON TO ALL ACTUATOR ASSEMBLIES. HENCE, NEITHER COVERS NOR SHAFTS ARE SHOWN IN THESE VIEWS. SEE COVER AND SHAFT DETAILS ELSEWHERE IN THIS MANUAL.

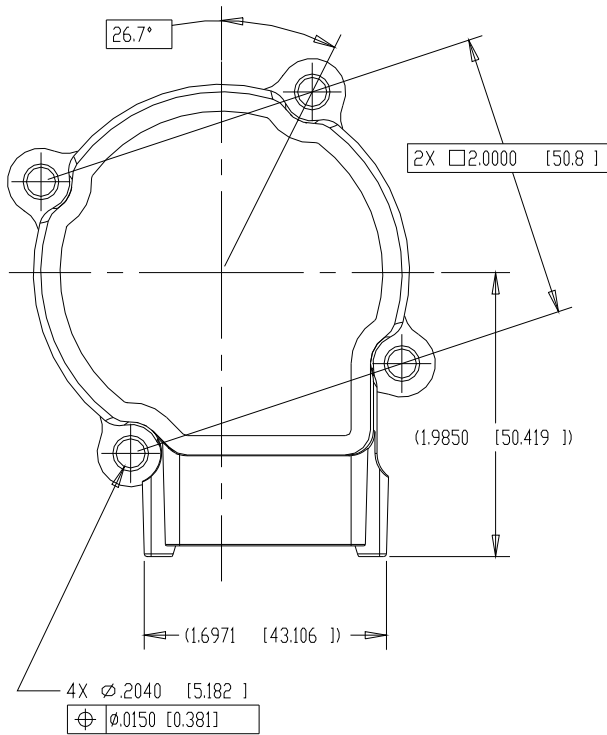

INTEGRATED DEUTSCH CONNECTOR (REF: DT04-12PA)		
ITEM	RECOMMENDED	OPTIONAL
MATING CONNECTOR	DT06-12SA-P012	DT06-12SA
SECONDARY LOCK	W12S-P012	W12S
SOCKETS	0462-201-16141	0462-201-16141
WIRING HARNESS STRESS RELIEF SUPPORT	WITHIN 16 INCHES FROM CONNECTOR	
NOTE: IN THE EVENT A WIRE IS NOT USED FOR EACH OF THE 12 PINS ON THE CONTROL, A DEUTSCH 114017 PLUG MUST BE USED IN PLACE OF EACH MISSING WIRE TO ENVIRONMENTALLY SEAL THE CONTROL.		

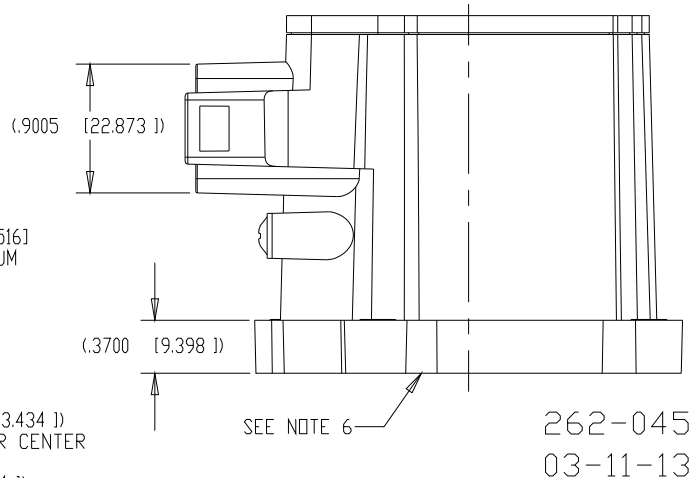
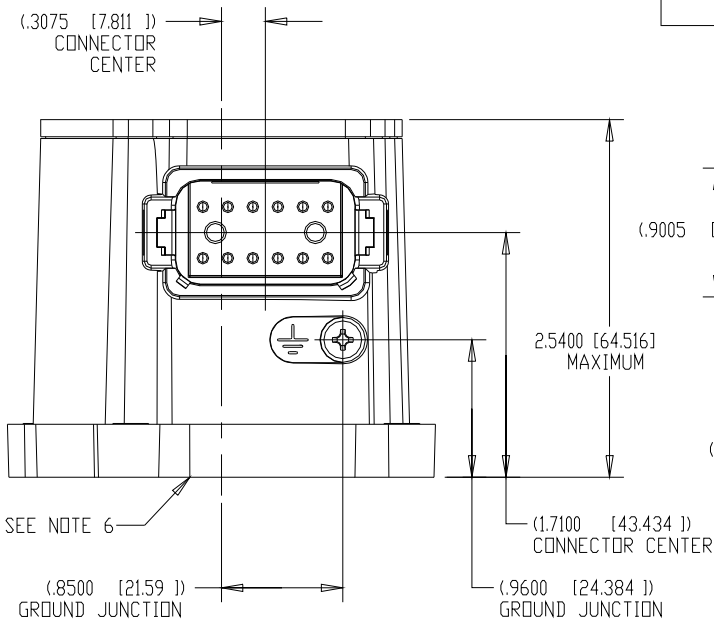

262-045
03-11-13

Figure 2-2. L-Series Outline Drawing

COVER TYPE 1

INTERNAL LIP SEAL
SHAFT TYPE 1 PHANTOM / INCHES [MM]

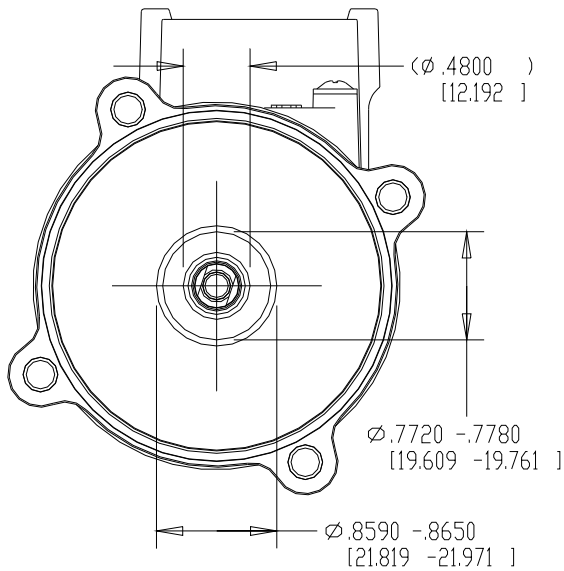
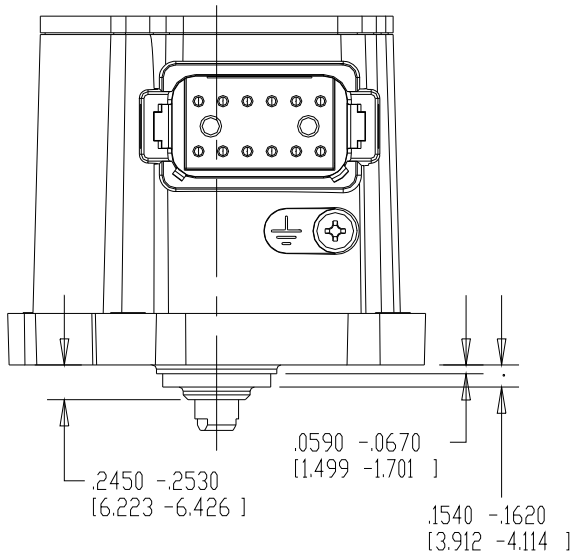

COVER TYPE 2

EXTERNAL SPRING-LOADED LIP SEAL
SHAFT TYPE 1 PHANTOM / INCHES [MM]

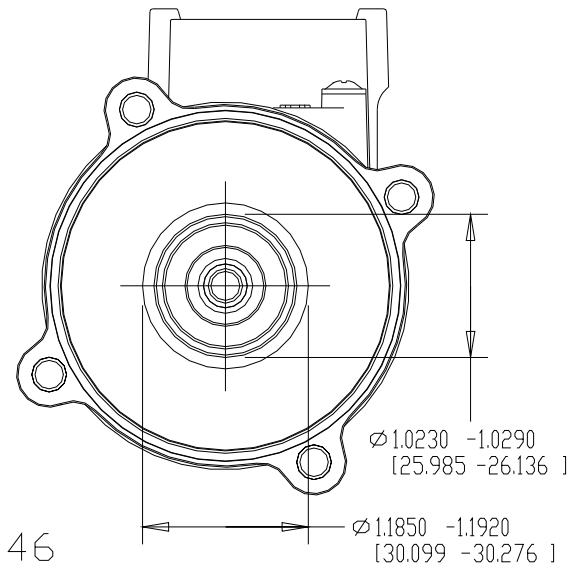
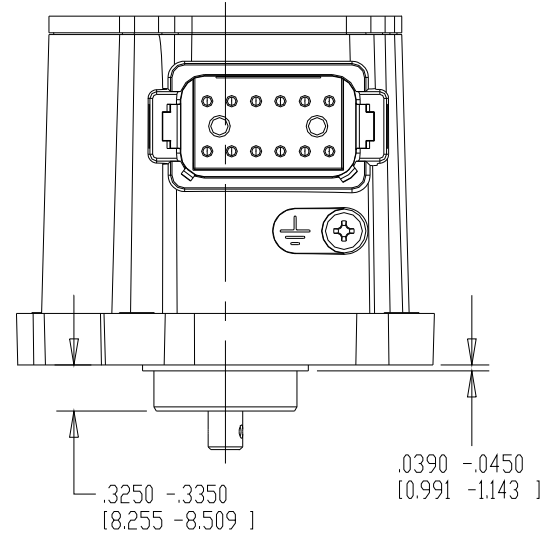

262-046
03-11-13

Figure 2-3. L-Series Cover Types

SHAFT TYPE 1

2X FLATS, THREADED AXIAL HOLE
COVER TYPE 1 PHANTOM / INCHES [MM]

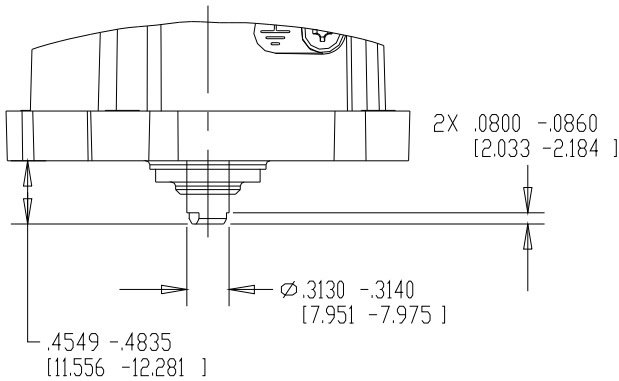

SHAFT TYPE 2

Ø.2480, 1X CROSS HOLE
COVER TYPE 2 PHANTOM / INCHES [MM]

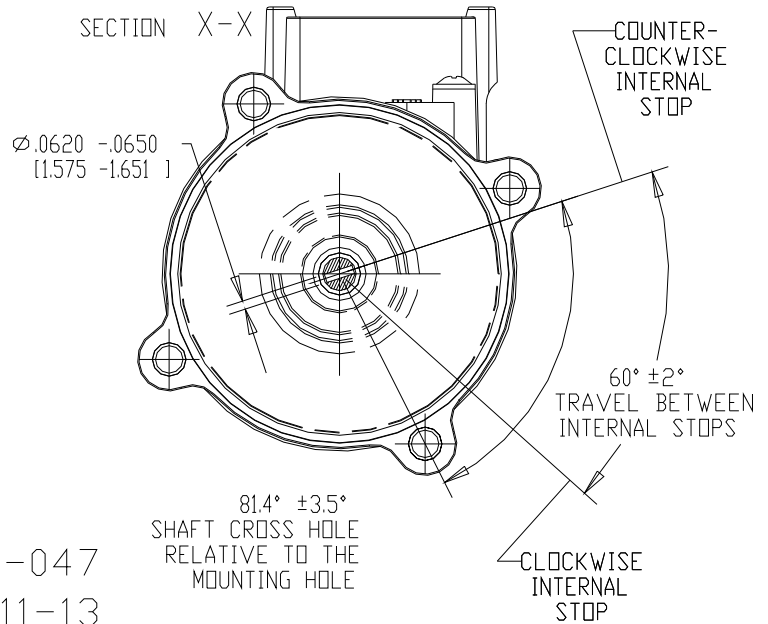
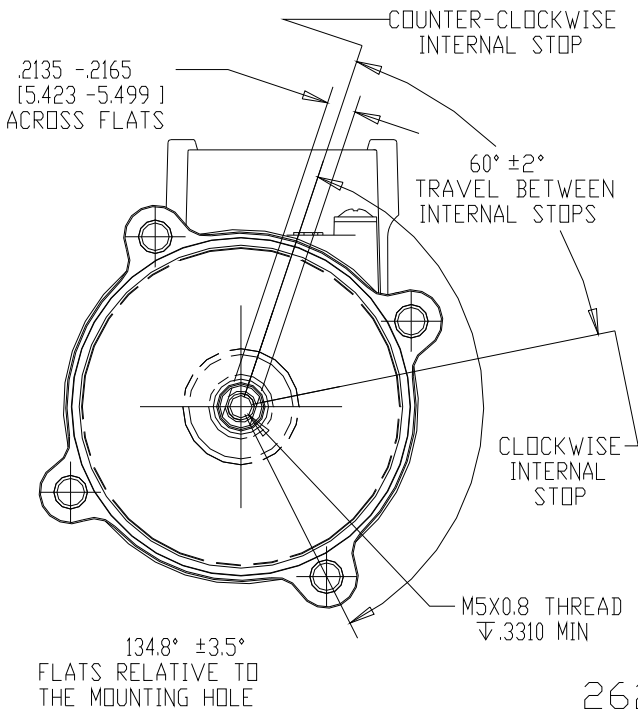
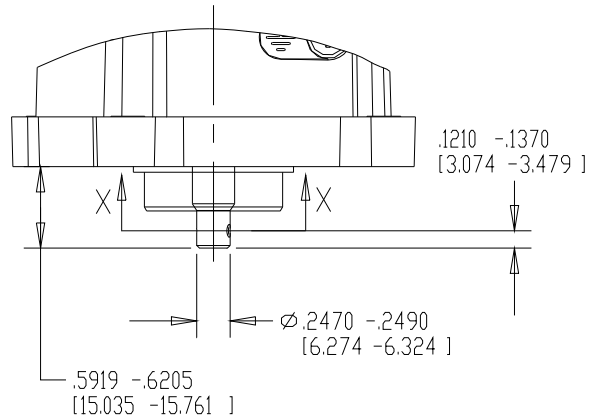

262-047
03-11-13

Figure 2-4a. L-Series Shaft Types

SHAFT TYPE 3

Ø.3095, 1X CROSS HOLE
COVER TYPE 1 PHANTOM / INCHES [MM]

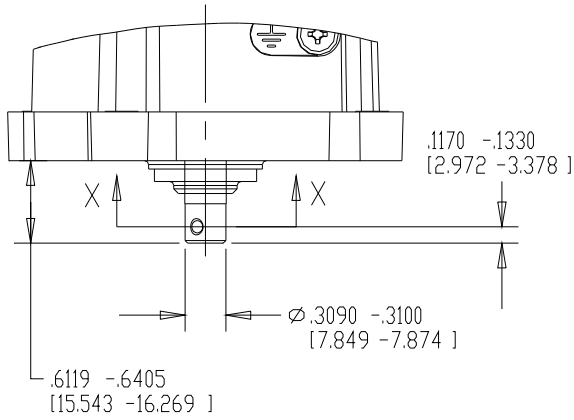

SHAFT TYPE 4

Ø.2480, 1X CROSS HOLE
COVER TYPE 1 PHANTOM / INCHES [MM]

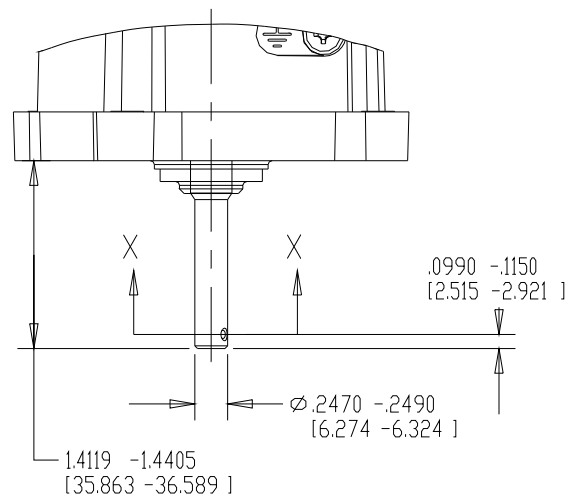

SECTION X-X

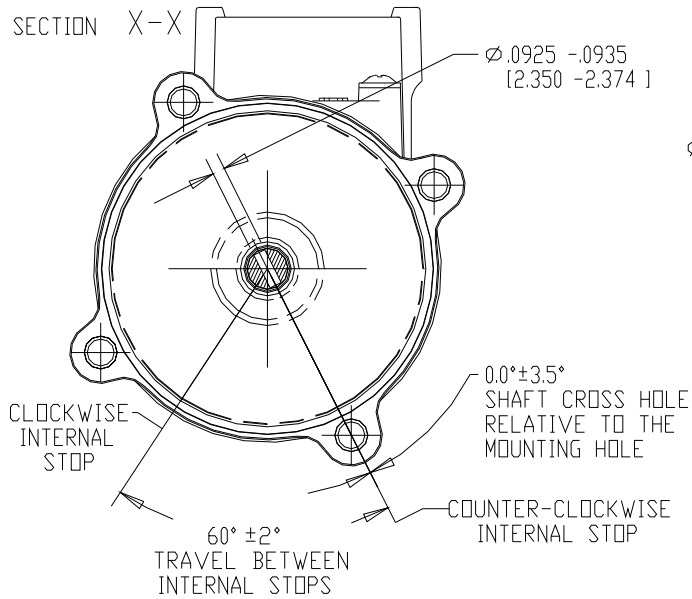

SECTION X-X

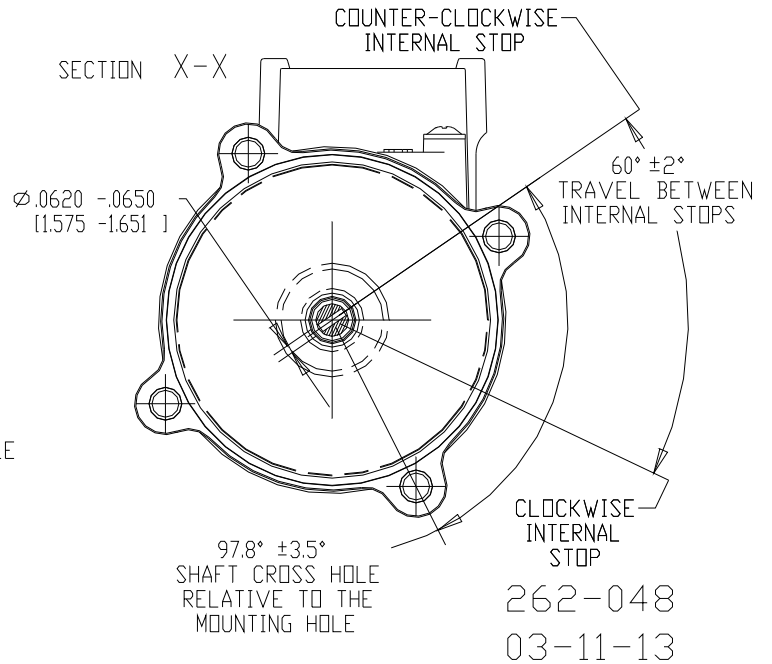

262-048
03-11-13

Figure 2-4b. L-Series Shaft Types

SHAFT TYPE 5

∅.2480, 1X CROSS HOLE
COVER TYPE 1 PHANTOM / INCHES [MM]

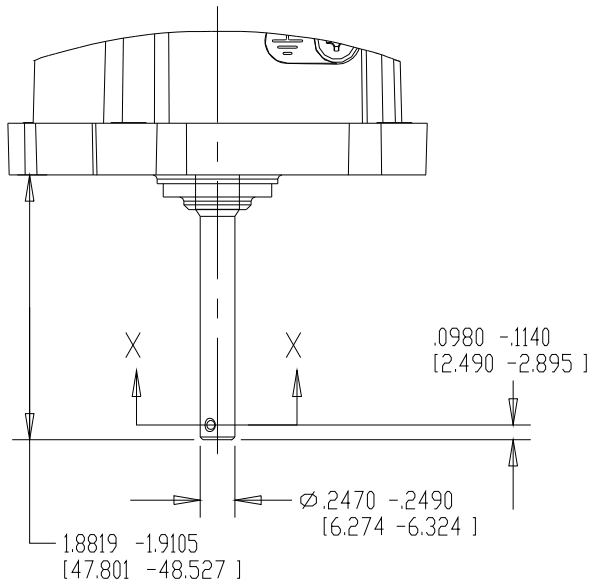

SHAFT TYPE 6

∅.2480, 2X CROSS HOLE
COVER TYPE 1 PHANTOM / INCHES [MM]

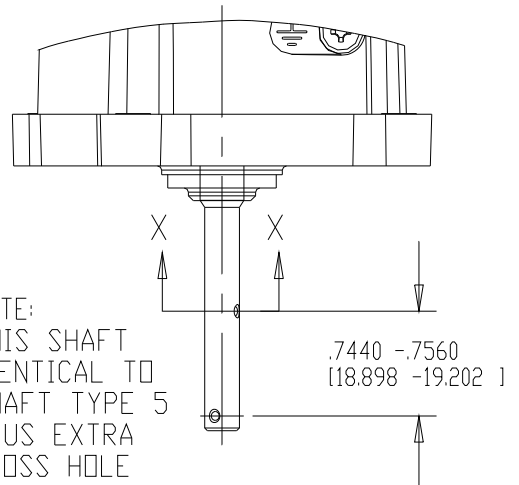

SECTION X-X

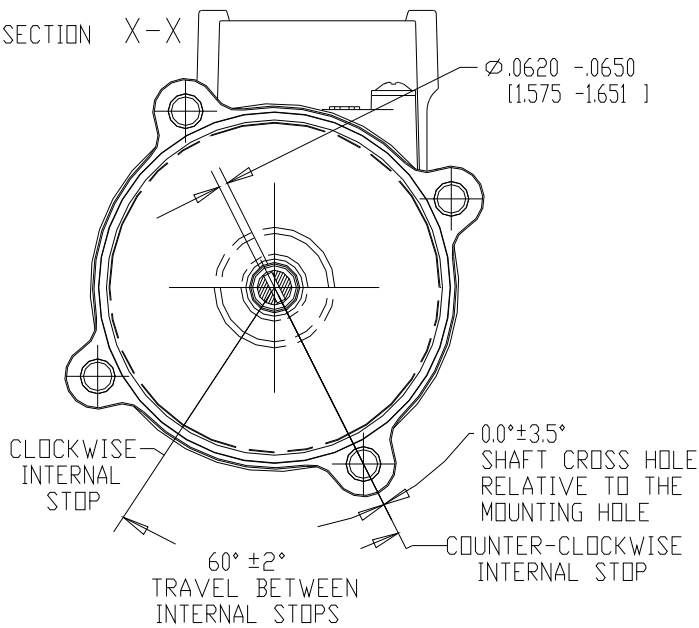

SECTION X-X

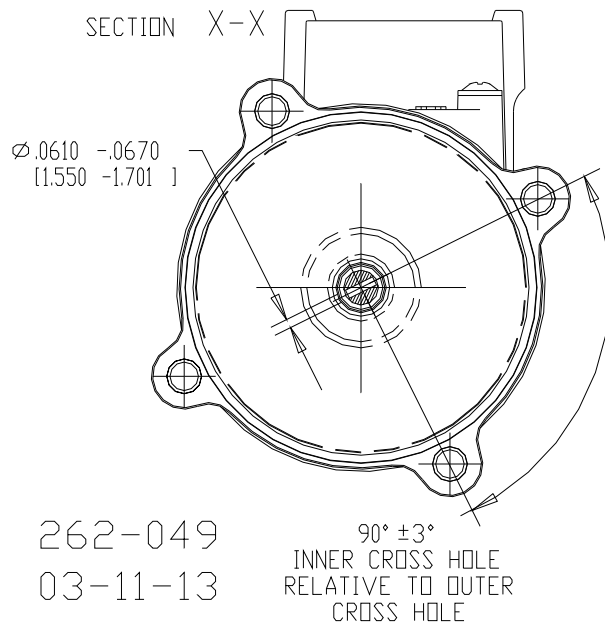

262-049
03-11-13

Figure 2-4c. L-Series Shaft Types

Chapter 3.

Electrical Installation

Introduction

This chapter provides instructions on how to connect the L-Series control into a system. A wiring pinout of the L-Series control, as viewed by looking into the control's connector feature, is shown in Figure 3-1. Typical connections to external devices are also shown.

The L-Series has an operating voltage range of 10 to 32 Vdc with nominal voltages of 12 or 24 Vdc. The power supply is reverse polarity protected, and consumes 32 W maximum power at a peak current of 1 A (32 V) assuming 4 Ω stator resistance at 25 °C. These assumptions are based on the fact that the software limits the power to the rotary actuator to 25 W at any given time and input voltage (in the valid range).

The control system should be protected with a 6 A fuse in the voltage supply lines. Typical max average current is 2.1 A, or max 25 W at 12 V. The application should be configured to turn on power to the actuator when the engine is first cranked.

NOTICE

Centralized load suppression is required when using an L-Series. The L-Series power supply input is not designed to withstand transient events typical of industrial or automotive environments (alternator load dump or power line surge). The centralized suppression must limit transient events to less than 45 V at the L-Series input power terminals.

Shielded Wiring

The use of cable with individually shielded-twisted pairs is required where indicated by the control wiring diagram (Figure 3-1). Cable shields must be terminated as indicated in the control wiring diagram using the installation notes described below. DO NOT attempt to directly ground the shield at both ends or an undesired ground loop condition may occur. If it becomes necessary to terminate the shield at the end opposite of the L-Series, it must be done through a high-frequency capacitor.

Installation Notes

- Wires exposed beyond the shield should be as short as possible, not exceeding 50 mm (2 inches).
- The shield termination wire (or drain wire) should be kept as short as possible, not exceeding 50 mm (2 inches), and where possible the diameter should be maximized.
- Installations with severe electromagnetic interference (EMI) may require additional shielding precautions. Contact Woodward for more information.

Failure to provide shielding can produce future conditions which are difficult to diagnose. Proper shielding at the time of installation is required to assure satisfactory operation of the product.

Electrical Connections

WARNING

EXPLOSION HAZARD—Do not connect or disconnect while circuit is live unless area is known to be non-hazardous.

Substitution of components may impair suitability for Class I, Division 2 or Zone 2 applications.

Prior to installation, refer to the wiring diagrams and the representative I/O interfaces schematic in this chapter. Also, review the hardware I/O specifications in Appendix B.

WARNING

The control will only meet ingress protection specifications while the Deutsch connector is installed in the unit. As such, the unit should not be exposed to operating environments unless the mating connector is installed. In addition, if a wire is not used for each of the 12 pins on the control, a Deutsch 114017 plug must be used in place of each missing wire. Failure to adhere to these guidelines may result in product failure or decreased life.

Use 1 to 1.5 mm² (16 to 18 AWG) stranded copper wire with insulation that meets temperature requirements in the harness design. A wiring harness stress relief within 400 mm (16") of the control's connector is recommended. Limit all I/O and signal lines to less than 30 m (98 ft). Also limit input power (B+/B-) connections to an earth grounded battery or conditioned power interface to less than 10 m (33 ft) from the L-Series product.

IMPORTANT

A conditioned power interface is an interface which offers equivalent common mode and differential mode conditioning of that of a grounded 24 V lead acid battery.

Dress the harness with wire loom to contain it in a single bundle. Use grommets when passing the harness through metal panels.

Connector

The following Deutsch connector components are recommended for harness designs:

	Recommended	Optional
Mating Connector	DT06-12SA-P012	
Secondary Lock	W12S-P012	
Sockets	0462-201-16141	1062-16-0122
Crimp Tool	HDT-48-00	DTT-16-00
Sealing Plug	114017	

For convenience, Woodward part number 8928-396 is a kit that provides all the necessary Deutsch components (crimp tool *not* included).

IMPORTANT

Crimping methods for the Deutsch connector pins must be followed as prescribed by the manufacturer. Woodward is not responsible for damage or loss of performance resulting if any other method of crimping is used. Use of the listed part numbers of Deutsch connector components is strongly recommended.



WARNING Due to the hazardous location listings associated with this product, proper wire type and wiring practices are critical to operation.

NOTICE

Do not connect any cable grounds to “instrument ground”, “control ground”, or any non-earth ground system. Make all required electrical connections based on the wiring diagram (Figure 3-1a, 3-1b).

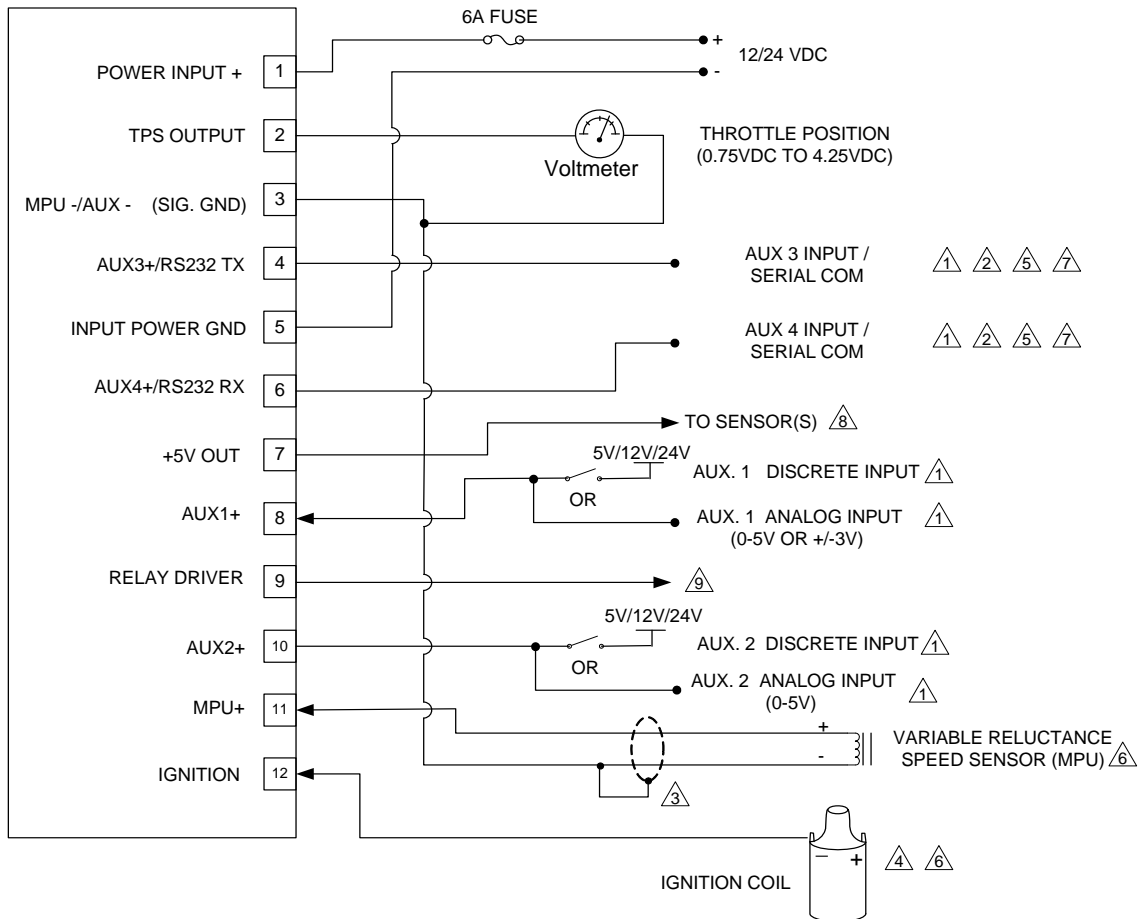

NOTES:

- ① REFERENCE ALL DISCRETE AND ANALOG INPUTS TO PIN 3 (SIG GND). TO PREVENT ELECTRICAL NOISE EMISSIONS FROM INTERFERING WITH THE AUX INPUT SIGNALS, IT IS RECOMMENDED THAT WIRING TO AUXILIARY (AUX) INPUTS **NOT** BE ROUTED WITHIN 150 MM (6 INCHES) OF ANY HIGH VOLTAGE IGNITION LEADS.
- ② AUX 3 AND AUX 4 CAN ALSO BE CONFIGURED AS DISCRETE OR ANALOG INPUTS IN A SIMILAR MANNER AS AUX 1 AND AUX 2, BUT ARE NOT FUNCTIONAL WHILE SERIAL COMMUNICATIONS ARE CONNECTED.
- ③ ALL SHIELD TIES ARE TO BE *NO LONGER THAN 2"* BETWEEN THE CABLE AND GROUND.
- ④ IF USING IGNITION SPEED INPUT OPTION, CONNECT PIN 12 OF THE L-SERIES SPEED CONTROL TO THE NEGATIVE TERMINAL OF THE IGNITION COIL. THE IGNITION SYSTEM COMMON MUST BE REFERENCED TO THE L-SERIES SPEED CONTROL GROUND (PIN 3 OR PIN 5).
- ⑤ USE WOODWARD KIT 8923-1061 TO CONNECT TO A COMPUTER FOR USE WITH THE SERVICE TOOL.
- ⑥ SPEED INPUT IS ACCOMPLISHED BY USING EITHER THE MPU OR THE IGNITION INPUT. DO NOT CONNECT WIRES TO BOTH INPUTS SIMULTANEOUSLY.
- ⑦ WHEN CONFIGURED AS AN ANALOG INPUT, THE FULL SCALE RANGE IS 0-5V.
- ⑧ THE 5V OUTPUT IS PROVIDED FOR POWERING EXTERNAL SENSORS. RATED AT 10mA MAX.
- ⑨ LOW-SIDE DRIVE OUTPUT DESIGNED TO DRIVE A RELAY, LAMP, OR OTHER STATUS INDICATOR. MAXIMUM CURRENT ALLOWED THROUGH THE COIL OR LAMP IS 500mA. MAXIMUM VOLTAGE ALLOWED AT THIS TERMINAL IS 32VDC.

Figure 3-1a. Typical L-Series Speed Control Application Wiring

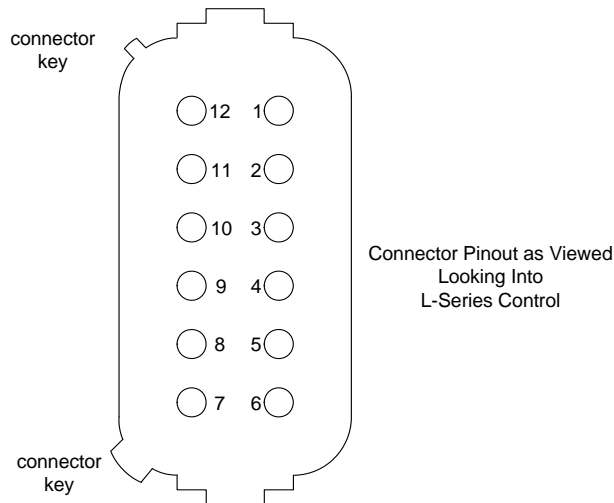

Figure 3-1b. L-Series Speed Control Connector Pin Arrangement

Connector Pin #	Description	Comment
1	+12V/24 Vdc Input Power	Supply power
2	TPS Signal Output	Direct position feedback output indication
3	PWM – / AUX –	Ground for AUX inputs
4	RS-232 transmit / Aux Input 3	Combination Aux 3 input and service tool input
5	Input Power Ground	Ground for the 12 V/24 V input power
6	RS-232 receive / Aux Input 4	Combination Aux 4 input and service tool input
7	5 V Out	Power for external sensors (10 mA max)
8	Aux Input 1	Aux 1 input
9	Relay Driver Output	Status / fault detection output
10	Aux Input 2	Aux 2 input
11	MPU +	MPU or Prox Probe speed signal input
12	Ignition Input	Ignition speed signal input

Description of Electrical I/O

Representative circuitry for the L-Series inputs/outputs is provided in Figure 3-6 below.

Power Supply Input (+12 Vdc/24 Vdc at pin 1, ground at pin 5)

The L-Series will handle a voltage range of 10 to 28 Vdc at full specified torque. The actuator is functional in the range of 8 to 32 Vdc, but accuracy and/or torque can be diminished at the extreme ends of this range.

The power supply terminals are reverse polarity protected, and in the case that a reverse polarity condition exists, the L-Series actuator will not power-up and will remain at the minimum stop if attached to a throttle body with an internal return spring.

Woodward recommends using a 6 A fuse on the power supply line feeding pin 1 of the L-Series actuator.

The supply voltage failure levels are below 6.25 V and above 33 V. The unit can be configured to either alarm or shut down upon detection of a supply voltage fault.



The input power must be fused. Failure to fuse the L-Series could, under exceptional circumstances, lead to personal injury, damage to the control valve, and/or explosion.

Take special care when wiring the L-Series control.

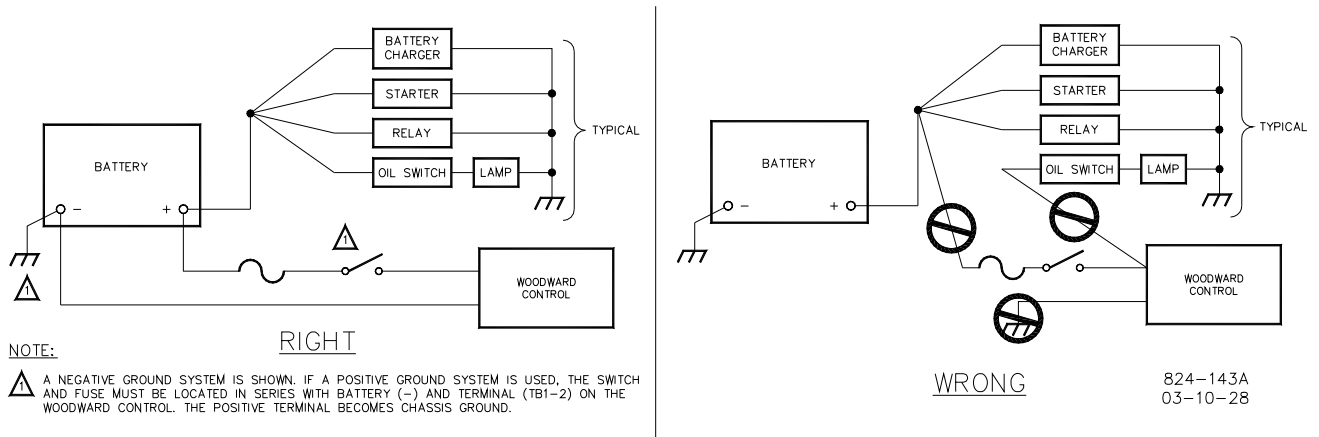





Figure 3-2. Correct and Incorrect Wiring to Power Supply

Ground Symbol Conventions

 = **Internal Circuit Board Common**
 Used to show equipotentials in electronic circuits, normally internal to a control system.

 = **Earth Ground**
 Represents a connection to "Earth" Ground.

 = **Chassis Ground**
 Sometimes used as symbol for system ground. Normally associated with connection to engine skid or vehicle frame. In the case of the L-Series, it also represents system ground.

 = **Protective Earth Ground.**
 Normally used as a safety ground in high-voltage (> 42V) systems. (Not applicable to L-Series Controls)

The control will continue to function down to a supply voltage of 8 V, to withstand a prime mover start from the same battery system, however the control will not function completely within specifications. During the low voltage, the L-Series will **not** meet the transient response times or the max torque output.

Speed Input

The L-Series speed input can be either from a magnetic pick-up (MPU) or from ignition system pulses. The input must be wired to the appropriate input and must be configured properly using the Service Tool prior to operation.

See Woodward manual 82510, *Magnetic Pickups and Proximity Switches for Electronic Controls*, for information about MPUs and installation of the pickup unit.

Speed (MPU or Prox Probe) Input (+MPU at pin 11, –MPU at pin 3, optional 5 V OUT at pin 7)

The L-Series MPU input will accept speed signals from variable reluctance (VR) or proximity probe devices in the range of 1 Hz to 12 kHz.

For an MPU, the acceptable amplitude range is from 1 to 42 Vrms. For a proximity probe, an optional 5 V power output (10mA max) is provided by the L-Series. The input is compatible with NPN proximity probe speed sensors, not PNP. The Proximity probe option with internal pull-up is available only with firmware versions 5418-1680 rev D or newer. The firmware version can be found on the Identification tab of the Service Tool.

IMPORTANT

If the signal from one MPU is split to two different devices, then a 1 Vrms signal will not be adequate, and the MPU voltage must be 3 Vrms minimum.

With either speed sensor option, the L-Series expects engine speed pulses present on pins 11 (MPU+) and 3 (MPU–). The number of flywheel or gear teeth that pass the speed probe for one crankshaft revolution must be programmed for proper speed signal detection.

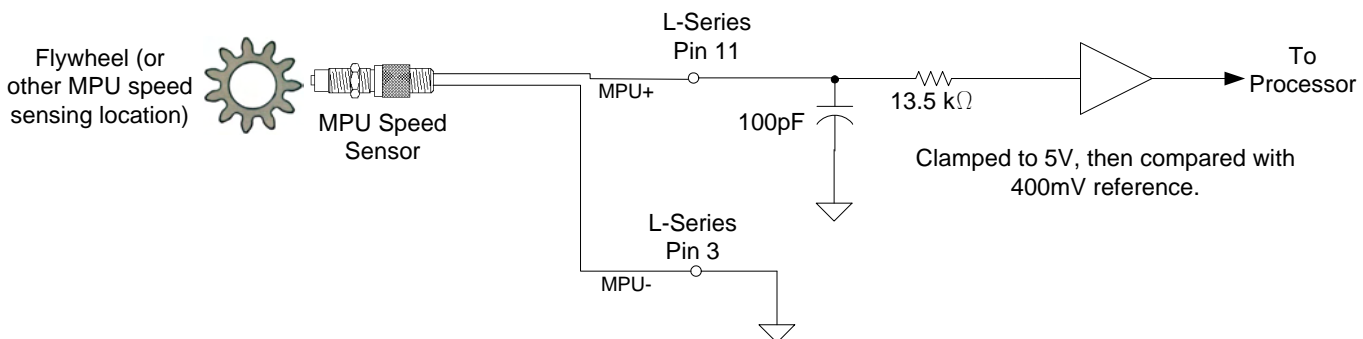

Figure 3-3. MPU Speed Sensing Input

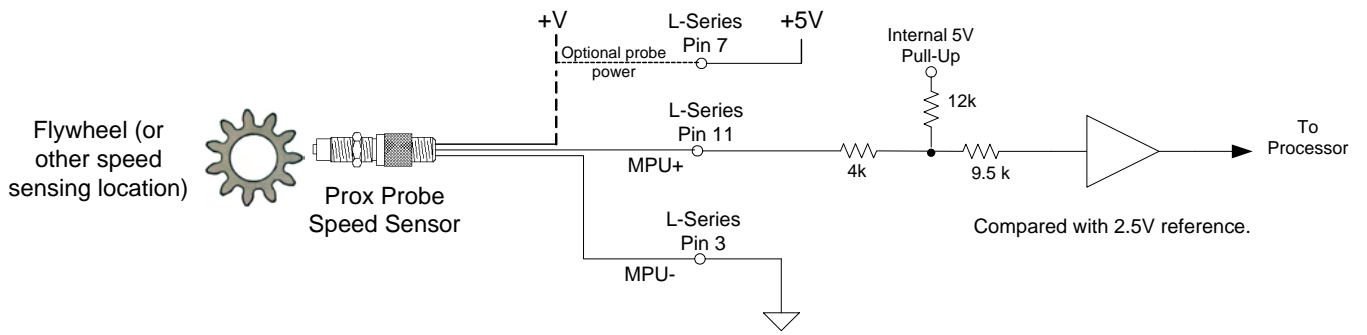

Figure 3-4. Proximity Probe Speed Sensing Input (5418-1680 rev D or newer only)

IGN (ignition) Input (+IGN at pin 12, -IGN at pin 3)

The L-Series control will accept a 1–480 Hz signal from an ignition input of a 2- or 4-cycle 1–20 cylinder engine. For standard coil ignition, the source may be the negative terminal of the coil primary. For distributorless or DIS (Direct Ignition System) systems, the source for the ignition pulses may be two ignition leads from the spark control connected to IGN+ (pin 12) and IGN- (pin 3). Take care not to reverse IGN+/- on a DIS system, or no speed will be sensed.

This function requires engine speed pulses present on pin 12 (IGN) of the control. The type of engine (2-stroke or 4-stroke) and the number of cylinders (1 to 20) must also be programmed.

IMPORTANT To prevent electrical noise emissions from interfering with the AUX input signals, it is recommended that wiring to auxiliary (AUX) inputs *not* be routed within 150 mm (6 inches) of any high voltage ignition leads.

** This is a typical ignition input setup. For DIS applications, refer to instructions in text above.**

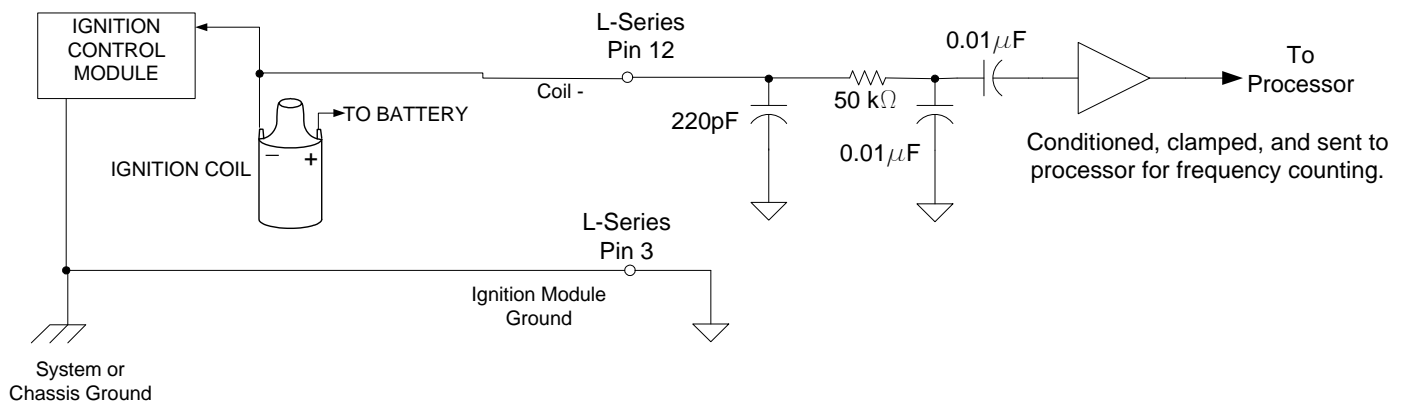

Figure 3-5. Ignition Speed Sensing Input

WARNING It is recommended that the actual engine speed be used to externally verify that the speed command matches the command signal sent. Failure to comply with this recommendation can result in undetected system faults.

TPS Output (pin 2, referenced to either pin 3 or pin 5)

The L-Series provides a 0–5 V signal representing actual shaft rotational position, where 0.75 V and 4.25 V correspond to full counterclockwise to clockwise rotation, respectively. This signal is fed directly off the position sensor to ensure no delays are introduced by the processor. However, this signal is also uncorrected, so the difference between this signal and actual position can vary up to $\pm 10\%$ over the operating temperature range. This gives the end user an indication of throttle position.

IMPORTANT

This output is meant for an approximate indication of shaft position only. The unconditioned output accuracy must be considered when using this signal externally. Refer to the specifications section for TPS accuracy.

WARNING

Do not try to inject signals *into* the TPS output, as it will negatively impact the performance of the L-Series actuator. This output is meant to be used with a high impedance device, such as a voltmeter. Do not tie pin 2 directly to battery or ground. If the application does not use this output, leave it open.

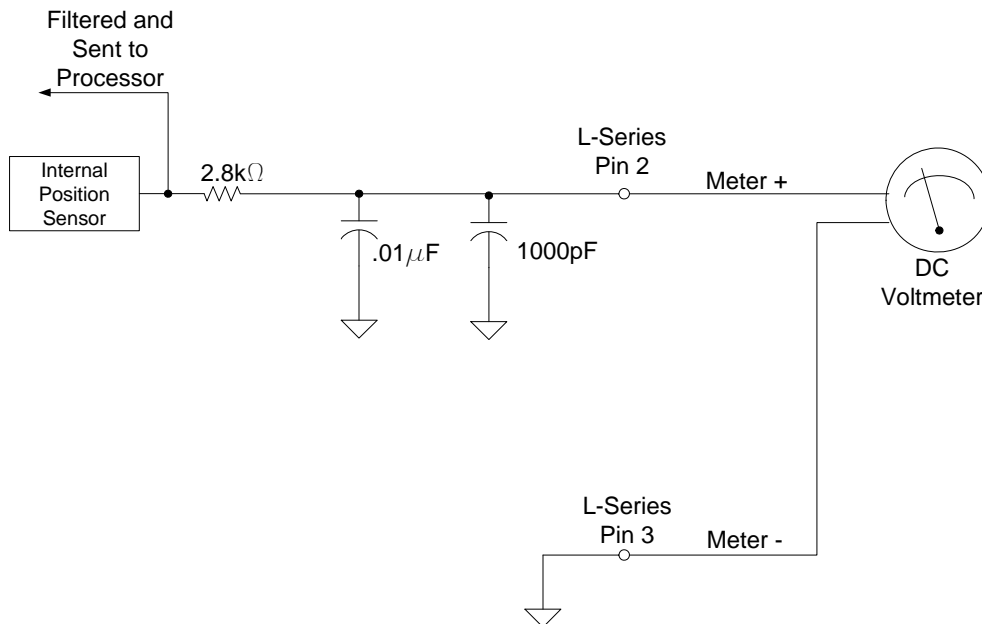

Figure 3-6. TPS Output

Relay Driver Output (pin 9)

A discrete output is provided to serve as a status indicator. This switchable discrete output is a closure to ground capable of sinking 250 mA with an output voltage rise of less than 1.5 V, and it is available to power external relays for devices such as alarms or fuel shutoff solenoids. The circuit is protected internally against over-current and inductive spikes, so external clamping is not necessary.

This output can be configured to be either normally on/closed (preferred failsafe setting) or normally off/open. In addition, the faults that drive the relay status can be configured individually. For details, refer to Chapter 4 (Service Tool). By default, this circuit will be configured in a failsafe manner, meaning it will be active (conducting) when no fault exists, but if power is lost or a fault is detected by the L-Series actuator, the circuit will open. See Figure 3-7 below for typical usage of this feature.

There are two conditions that will prevent the discrete output from operating correctly. The first is if battery positive is accidentally connected to it, and the second is if it is shorted to ground. The circuit will protect itself in the event of a mis-wire, but it will hold the output open(floating) until the fault is removed.



WARNING

It is recommended that the Relay Output be configured for the failsafe 'Normally On' mode, to ensure maximum fault protection and annunciation. Failure to follow these guidelines could, under exceptional circumstances, lead to personal injury and/or property damage.

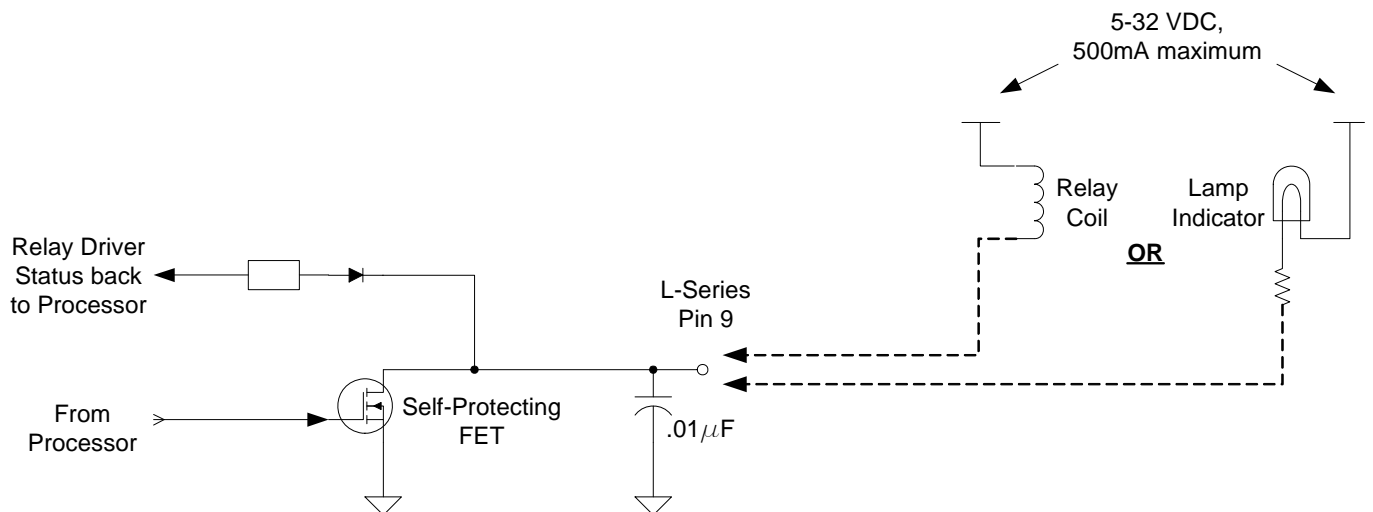

Figure 3-7. Relay Driver Output

5V Output (pin 7, referenced to pin 3)

A 5 Vdc output has been provided on the L-Series actuator to power external sensors, if necessary. The 5 V output is limited to 10 mA, but this is sufficient for most light-duty ratiometric sensors

IMPORTANT

All connector pins are short-circuit protected to ground and power except pins 3 and 5, which are not protected against shorts to battery positive. Installation of a fuse on the power ground wire to pin 5 would provide protection to these pins but does not mean a fuse is not needed in the power connection. Pin 1 (B+) still needs protection against a short to ground.

AUX INPUTS (+ at pins 4, 6, 8, and 10; ground at pin 3)

There are four auxiliary inputs on the L-Series control, all of which are capable of both analog and discrete functions. The Aux functions (below) are mapped to Aux inputs using the Service Tool. If desired, multiple functions can be mapped to a single Aux input. For added flexibility, discrete functions can be programmed to be always on or always off as well as open or closed for the selected function. Analog inputs can also be inverted (direction reversed).

Although they are very flexible, two Aux inputs are shared with the serial communications, and will be unavailable if the L-Series is connected to the Service Tool. However, a means of simulating these inputs is provided for test purposes through the Service Tool interface.

The functions available for AUX input configuration are:

- Isochronous Loadsharing analog input
- Remote Speed Setpoint analog input
- MAP/Boost Fuel limit analog input
- Rated 1 / Rated 2 (50/60 Hz) digital input
- Raise Speed Setpoint digital input
- Lower Speed Setpoint digital input
- Isoch/Droop digital input
- Idle/Rated digital input
- Alternate Dynamics digital input
- Run Enable digital input

The Service Tool communicates over RS-232 using Aux inputs 3 and 4. Whenever connected, the configured Aux input is bypassed (ignored).

Aux X Input Options

Aux1 (0–5 V analog, ± 3 V analog, discrete input)

Aux2 (0–5 V analog, discrete input)

Aux3 (0–5 V analog, discrete input, service tool RS-232)

Aux4 (0–5 V analog, discrete input, service tool RS-232)

Connecting an auxiliary input pin to battery positive voltage activates it, assuming the input is configured for Active Closed. Removing battery voltage from an input pin or shorting the pin to ground deactivates the input. If not using battery voltage with the auxiliary digital inputs, it is recommended that at least 3 V be present on an input pin in order to change its state from inactive to active. For AUX2, AUX3, and AUX4, greater than 2.5 Vdc is considered high, and less than 0.8 Vdc is considered low. For the AUX1 discrete input only, the input must exceed 3 V to activate the discrete state. AUX3 and AUX4 are also used for digital communications such as RS-232 (service tool).

Figure 3-8 shows the most typical usage of the various auxiliary inputs.

IMPORTANT

Aux inputs 3 and 4 are used as service port connections, but can also be used as either discrete or analog inputs, much the same as Aux 2. When used as a service port, the analog and discrete functions will not work. Woodward recommends that the service port not be connected during normal use. It is intended for system setup and troubleshooting only.

IMPORTANT

To prevent electrical noise emissions from interfering with the AUX input signals, it is recommended that wiring to auxiliary (AUX) inputs *not* be routed within 150 mm (6 inches) of any high voltage ignition leads.

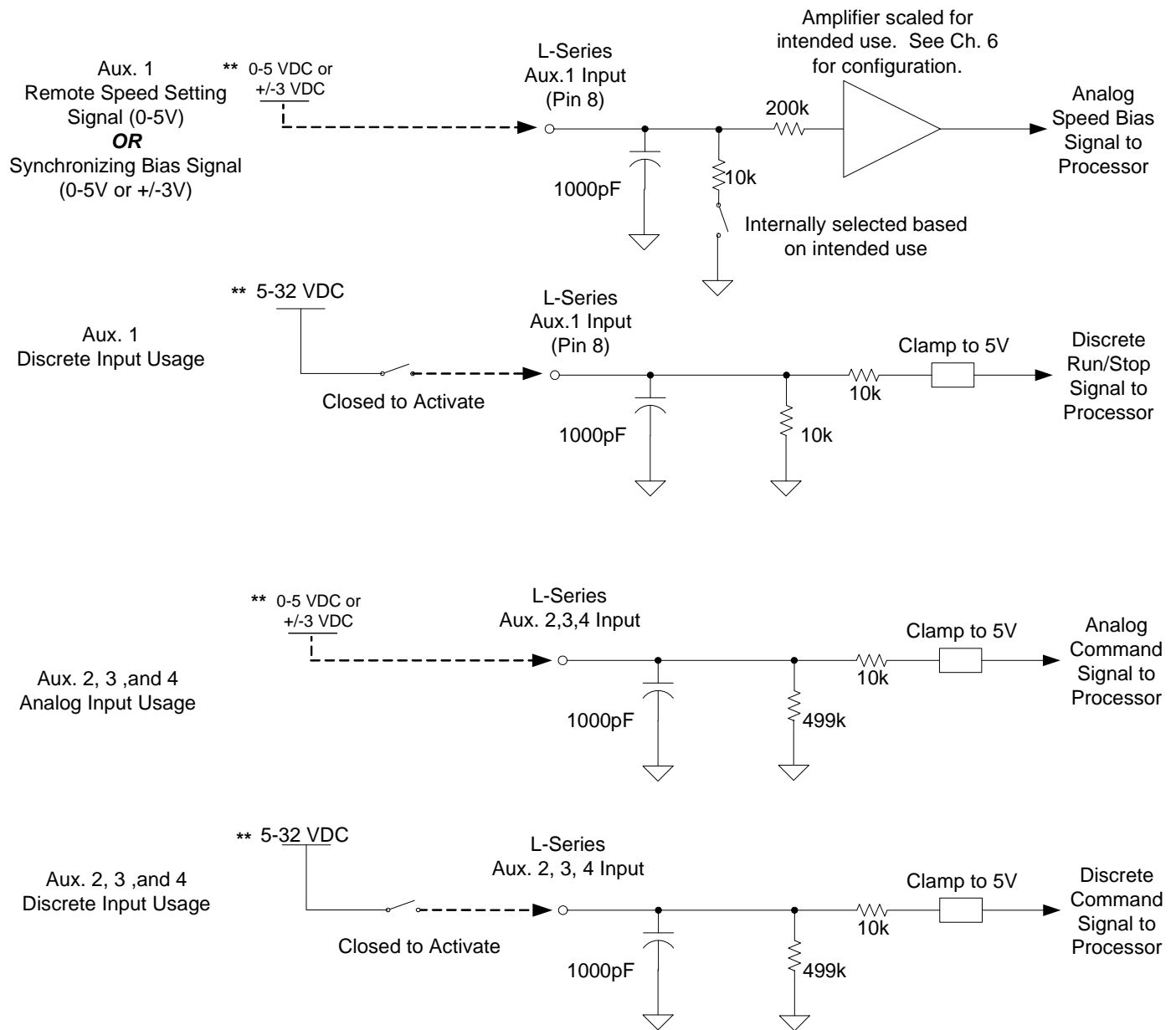

**** Reference all analog or discrete inputs to L-Series signal ground (Pin 3)**

Figure 3-8. Typical AUX Input Usage

Communications

RS-232 communications are available on the L-Series when used with an external transceiver connected to pins 4 and 6. Serial communications allow for the use of a service and configuration tool with the L-Series actuator. The simplest way to establish this interface is to use Woodward kit # 8923-1061.

Functions available through this port include tuning, monitoring, and configuration of the position control. Detailed driver status information is also available.

Any RS-232 wiring must meet the requirements in the EIA RS-232 Standard document. The RS-232 standard states that the length of the RS-232 cable between the driver and the PC must be less than 50 ft (15 m) with a total capacitance less than 2500 pF. The RS-232 data rate is fixed at 19.2 kbps. The communication port is non-isolated and susceptible to both EMI noise and ground loops related to PC connections and typical industrial environments.

RS-232 Connections (pin 4 and pin 6)

These pins are for serial communication with the L-Series actuator. An external RS-232 transceiver is necessary to make communications possible with the Woodward L-Series Service Tool. A connectivity kit can be purchased from Woodward to accomplish this. Further instructions for using this connectivity kit are provided in Chapter 4.

It is recommended that the OEM or packager provide a breakout cable that is connected to the L-Series service port and run to an easily accessible area on the engine. The service port is absolutely necessary to set up and troubleshoot the L-Series.

RS-232/Service Tool Connections (pin 4 and pin 6)

These pins are for serial communication with the L-Series actuator. An external RS-232 transceiver is necessary to make communications possible with the Woodward L-Series Service Tool. A connectivity kit can be purchased from Woodward to accomplish this. Further instructions for using this connectivity kit are provided in Chapter 4.

It is recommended that the OEM or packager provide a breakout cable that is connected to the L-Series service port and run to an easily accessible area on the engine. The service port is absolutely necessary to set up and troubleshoot the L-Series.

Any RS-232 wiring must meet the requirements in the EIA RS-232 Standard document. The RS-232 standard states that the length of the RS-232 cable between the driver and the PC must be less than 50 ft (15 m) with a total capacitance less than 2500 pF. The RS-232 data rate is fixed at 19.2 kbps. The communication port is non-isolated and susceptible to both EMI noise and ground loops related to PC connections and typical industrial environments.

Functions available through the Service Tool include tuning, monitoring, and configuration of the position controller. Detailed driver status information is also available. For details, refer to the Service Tool chapters of this manual.

IMPORTANT

The service port is not isolated and is not intended to function while the prime mover is in normal operation. The service port is provided for configuration and setup only.

Ground Junction (see Figure 3-9)

This grounding junction is provided for joining external ground wires. THERE IS NOT AN INTERNAL CONNECTION TO CIRCUIT GROUND. Terminal pins 3 and 5 must be used for access to the circuit ground. This junction point is completely electrically isolated from the L-Series actuator's electronics, and is solely for convenience during installation.

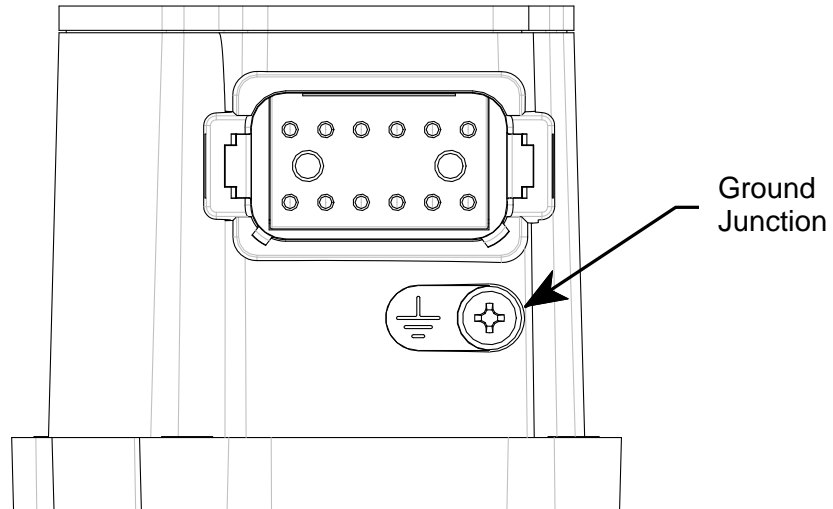

Figure 3-9. Ground Junction Point

Chapter 4.

Description of Operation

General

The L-Series Speed Control is an electric actuator with position feedback and an integrated digital speed control. The actuator output shaft connects to the fuel gas valve, intake throttle or fuel oil pump rack shaft of a reciprocating engine. The output shaft maximum rotation is 60 degrees and is configurable for cw or ccw rotation. A manual mode is provided to facilitate setting up the actuator system.

The speed setpoint can be adjusted by a remote 0–5 Vdc analog input or by discrete inputs (such as Idle/Rated, 50/60 Hz selection, 3-Speed, or Raise/Lower).

For generator applications, isochronous load sharing and synchronizing capability is available by a ± 3 Vdc analog input in place of the remote 0–5 Vdc analog input. A compatible load sharing/synchronizer device is needed to provide the load sharing/synchronizer input bias signal. Droop operation can also be configured.

Control adjustments are made using the L-Series Service Tool. The Service Tool is a Windows based software tool used to configure, monitor, adjust, and troubleshoot a L-Series speed control system. It runs on a personal computer and communicates with the L-Series speed control through a serial connection. The L-Series Service Tool includes optional password protection to provide security against tampering.

The speed sensor input contains a software-configurable filter that minimizes the effects of firing torsionals that occur normally in reciprocating engines. This filter ensures the actuator will not react to speed sensor input changes produced by firing torsionals. This provides exceptionally smooth steady-state speed control and allows matching the control dynamics solely to the engine rather than detuning dynamics for firing torsional frequencies.

The control has a switching power supply with excellent spike, ripple, and EMI (electromagnetic interference) rejection. Discrete inputs are capable of rejecting EMI and variable resistance in switch or relay contacts. Analog inputs are differential type with extra filtering for common-mode noise rejection.

The control provides one discrete output, which changes states based on pre-defined alarm or status conditions. The control also provides one 0–5 V analog output which provides a position feedback indication. This analog output may be used with an analog meter, recorder, or as input to a computer.

The control provides a communications port which can be used as an RS-232 serial interface. The RS-232 port is the service port used by the L-Series Service Tool to configure and tune the L-Series system.

System Operation

The L-Series actuator is ready for operation immediately (within 0.25 second) when the power supply is connected. Power may be connected to the control at the same time the engine starter motor is engaged.

On an engine shutdown command, the independent engine shutdown solenoid or solenoid valve in the fuel supply should be de-activated and the power supply disconnected from the speed control. This shutdown signal should be sent directly from the engine control panel and should be independent and separate from the L-Series control.



The L-Series control should not be used as the primary means of shutting down the engine.

Starting the Engine

A typical engine starting sequence will look like this, if no shutdown faults are detected:

When powered-up, the L-Series control will be in position control at the configured min position. If a Run Enable discrete input is configured, it must be closed. When the starter is engaged, the speed will increase above the Start Speed 1 Threshold, and the control will position the shaft to the Start Fuel position demand. If two Start Fuel positions are used and speed increases above the Start Speed 2 Threshold, the control will position the shaft to the Start Fuel 2 position setting. Once the engine speed is above the Run Speed Threshold, the control will switch from start fuel demand to the fuel demand from the speed control PID. At this point, the unit is in speed control and will control the engine to the speed setpoint. The PID position during starting is tracking the start fuel values, providing a bumpless transfer to speed control. At this point, the speed setpoint increases to the configured or selected setting—Idle, Rated, Rated 1, or Rated 2.

If a shutdown fault is detected, the control will drive the output to the configured fail direction position.

Control Features Description

As you review the following features, keep in mind that most applications will only require a few of the functions to be activated. The choices are available to provide maximum flexibility in a single package. The user must set up the actuator direction, speed input, setpoint logic, and desired I/O. From the dynamics functions area, the user can set as many or as few as is necessary for stable operation. The user can choose all or none of the fuel limiter functions, speed setpoint modifiers, alarm/shutdown functions, security and logic functions depending on the application.

The control I/O consists of input power, a speed input, 4 configurable aux inputs, a status output, and an actual position indication (see Figure 4-1).

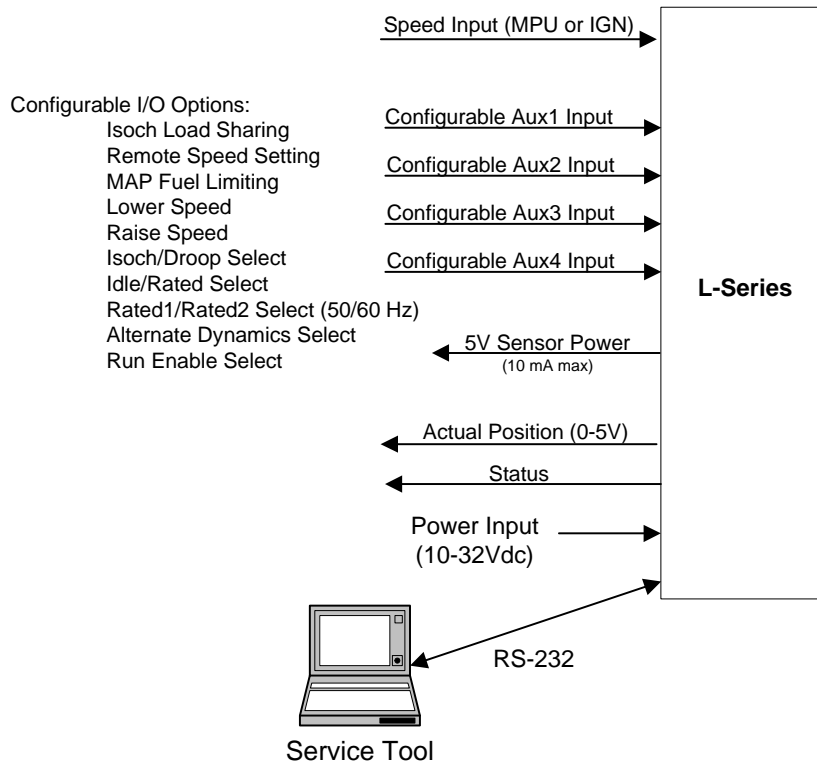

Figure 4-1 Overview of L-Series Inputs/Outputs

Speed Control Functions

The speed control consists of a speed input, speed setting logic, speed biasing logic, and speed dynamics options.

Speed Input

The L-Series control accommodates one speed input, from a magnetic speed pickup (MPU), proximity probe, or ignition input, which provides a speed signal to the control. A digital type of detection with firing torsional filtering is used for detecting engine speed. This digital detection method senses speed very quickly for rapid response to speed changes. The input frequency is converted to engine speed based on the gear teeth (if MPU or Prox) or number of cylinders and 2-/4-stroke settings (if ignition) configured.

Speed Settings and Ramps

The L-Series provides for local speed setpoint control by discrete raise and lower inputs. A 0 to 5 Vdc analog input provides for remote speed setpoint control. A ± 3 Vdc analog input provides for isochronous load-sharing and synchronizer control. Figure 4-2 provides a detailed overview of the setpoint modes and rates available.

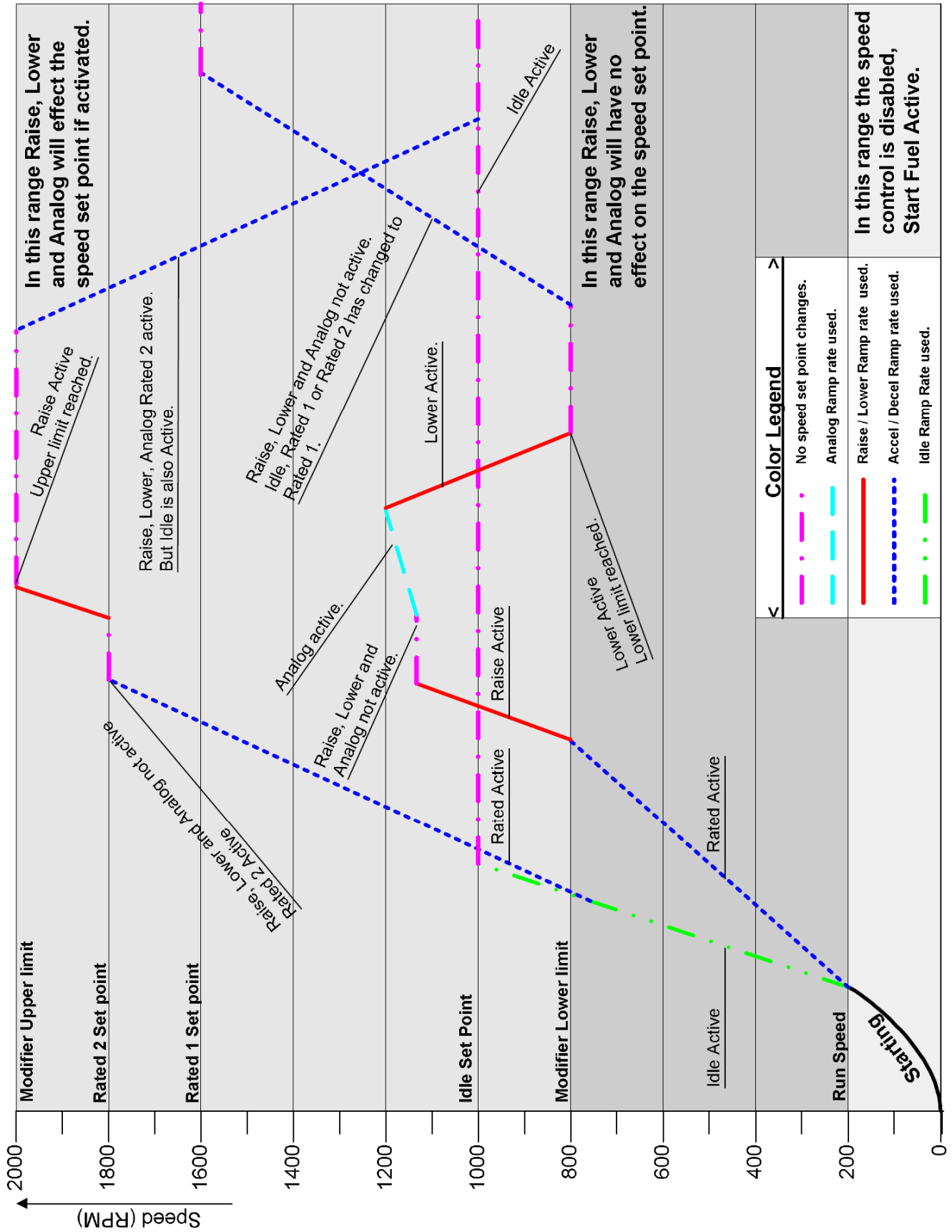

Figure 4-2 Speed Setpoint Actions and Rates

Speed Setting and Ramp Functions

The control provides run, idle, and two rated speed set points with a lower and raise limit, plus accel and decel ramps, raise and lower ramps, and a ramp to idle rate. All ramp rate settings are in rpm/s, and all speed setpoint changes are ramped for smooth setpoint transition. For emergency standby applications, a very high ramp rate effectively cancels the ramp function to provide rapid starting. The Ramp to Idle determines how fast speed is increased from run to idle speed. Accel rate determines how fast speed is increased from idle to rated speed. Decel rate determines how fast speed is decreased from rated speed to idle speed. The accel and decel rates are used when transferring between rated 1 and rated 2 speeds. Raise and lower rates determine how fast speed is increased or decreased by the raise and lower command inputs. Max Analog Rate is the maximum rate the speed can be increased or decreased by the remote speed setpoint input.

The Run Speed setting must be above cranking speed, but below the speed attained when running the start fuel limit position. The speed control activates at run speed by grabbing the current operating speed as the initial speed setpoint, then ramping the setpoint up to the idle speed setting at the ramp to idle rate. If the idle/rated input is set in the rated position, acceleration will pass seamlessly through idle speed to the selected speed setpoint (remote, rated 1, or rated 2) at the accel rate.

Speed Setting Options

The following section describes the various speed setting modes.

Single Speed (Rated) Select—If no speed biasing functions are enabled, the engine will run at one set speed. With this configuration, there is no external speed adjustment. Speed is held constant at the rated speed setting. However, the fuel limiters, run speed setting, and accel ramp are provided and active for light-off and acceleration control up to rated speed.

50/60 Hz (Rated 1/Rated 2) Select—This feature allows the user to switch the speed set point between a primary and secondary engine rated speed. A user-definable discrete input, configured as Rated1/Rated2, is used to toggle between the two set speeds. The input can be configured to select Rated 2 on either opening (active open) or closing (active closed) of the contact input. This mode can be configured for start-up select or runtime select.

Runtime Select—The user can toggle between the two speed settings at any time during operation. The transition rate between the two speeds is determined by the configured acceleration and deceleration rates. If the setpoint is increasing it will use the acceleration rate. If decreasing, the deceleration rate is used.

Start-up Select—When run speed is reached speed setpoint will ramp to Rated 1 or Rated 2 setpoint depending on the state of the Rated 1/Rated 2 discrete input. After run speed is reached the Rated 1/Rated 2 discrete input will have no effect until speed is below the stopping speed.

Idle/Rated Select—This feature allows the user to toggle the speed set point between an idle and a rated speed. A user-definable discrete input, configured as Idle/Rated, is used to toggle between the two set speeds. The input can be configured to select Rated on either opening (active open) or closing (active closed) of the contact input. The user can toggle between the two speed settings at any time during operation. During transitions, the acceleration and deceleration rates are used.

Idle/Rated is commonly used to provide an idle speed set point for engine warm-up or cool-down cycles. The Idle speed setting is independent of the lower limit set point and may be set at a lower speed. Idle speed cannot be changed except by adjustment of the software set point. The idle speed set point is selected during starting when engine speed exceeds the run speed setting or while running whenever the idle/rated contact is open (assuming an active closed configuration). Closing the idle/rated contact ramps the speed set point from idle to rated. The raise and lower commands increase and decrease engine speed based on the raise and lower rate settings. Closing either the Raise or Lower contacts while ramping from idle to rated immediately cancels the idle to rated ramp and speed follows the raise or lower commands for variable speed control. The raise and lower commands will not adjust the speed setpoint above the raise limit nor below the lower limit. The control ramps the speed setpoint at the raise or lower rate settings. Closing both the raise and the lower contacts enables the analog input for remote variable speed setpoint control, if configured. In Analog Mode the Analog Rate Limit is used.

Three-Speed Select—Some refrigeration applications may find it useful to have three engine speeds available: a highest speed for quick cool-down when warm goods are put into a container, a lowest speed to maintain the load's temperature once it has been cooled, and an intermediate speed for increased cooling if the container door is opened to move goods in or out. Typically, the discrete inputs for each of these speeds will come from an automatic thermostat, and only one will be high at a time. Mobile access platform (scissor lift) applications may also require three engine speeds, which correspond to three basic operating modes: static lift, transient lift, and mobile vehicle travel.

To provide this feature, two user-definable discrete inputs must be configured as Idle/Rated and Rated1/Rated2. The Idle/Rated input has the higher priority, if Idle is selected the setpoint will move to the idle speed setting. The Rated1/Rated2 input will determine the selected speed when the Idle/Rated input is selecting 'rated'. During transitions, the acceleration and deceleration rates are used.

Example: If the inputs are configured as follows, Idle/Rated = Aux3 (active closed) and Rated1/Rated2 = Aux4 (active closed), then the following summarizes the 3-speed selection.

Aux 3 (Idle/Rated)	Aux 4 (Rated 1/ Rated 2)	Selected Speed
Open	Open	Speed 1 (Idle)
Open	Closed	Speed 1 (Idle)
Closed	Open	Speed 2 (Rated 1)
Closed	Closed	Speed 3 (Rated 2)

Up to a five-speed select can be used if the Raise and Lower commands are configured and used as position selectors. When using Raise or Lower selections, the control ramps the speed setpoint at the raise or lower rate settings. This option may be desirable if another rate is needed.

Raise/Lower Adjust—This feature allows the user to change the speed set point with external discrete inputs. If both the raise and lower discrete inputs are closed, the lower has priority.

Lower—A user-definable discrete input, configured as Lower, acts directly on the internal speed set point within the L-Series control, and will progressively decrease the speed set point down to a programmable lower limit at the programmed lower rate for as long as the input is in a high state (assuming the input is configured as active closed). When this input goes low, the speed reference will remain fixed at the last setting reached the instant the input went low.

Raise—A user-definable discrete input, configured as Raise, acts directly upon the internal speed set point within the L-Series control, and will progressively increase the speed reference up to a programmable upper limit at the programmed raise rate for as long as the input is in a high state (assuming the input is configured as active closed). When this input goes low, the speed reference will remain fixed at the last setting reached the instant the input went low.

SPEED BIASING

Isochronous (Droop OFF)—This is the default speed biasing function if none of the other speed biasing functions are selected. This maintains the engine at one speed setting throughout operation regardless of load.

Droop—This feature allows for a change in speed set point with a change in load. This feature is primarily used when the generator is connected to a utility bus or paralleled with another genset on an isolated bus. In this situation, the utility will determine the frequency of the alternator.

Droop is a tunable value that decreases the speed setting when load increases as determined by the actuator output position. Droop is set as a percentage of rated speed (or Hz). Actuator positions must be entered for no-load and full load to correlate the speed setting to load. A setting of 0% droop disables the Droop function.

The desired engine speed reduces with the following formula:

$$\frac{\text{speed reference} * \text{droop percentage} * (\text{actual position} - \text{no load actuator position})}{(\text{full load actuator position} - \text{no load actuator position})}$$

The speed offset calculated is determined by the user-configured droop percentage, no load actuator position, and full load actuator position parameters.

Droop is off at start-up, and is enabled at speeds above Idle.

A user-definable discrete input, configured as Droop, can optionally be used to transfer between droop and isochronous control.

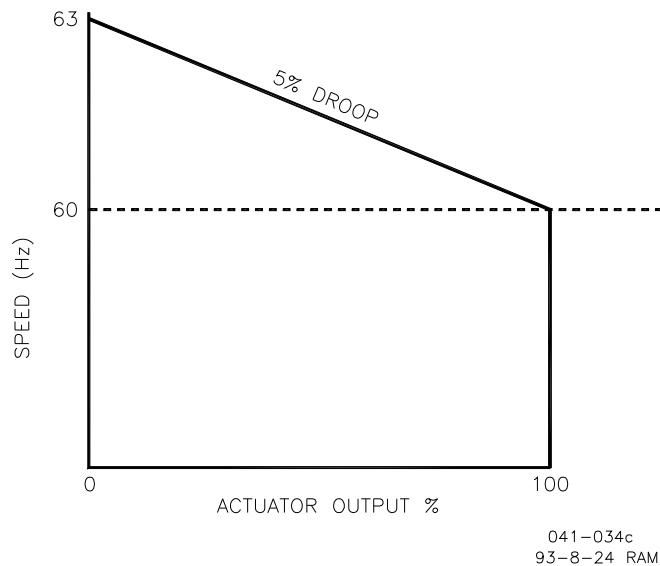

Figure 4-3. 5% Droop Example

Analog Biasing—This feature allows the user to alter the speed setpoint with an external signal. The input can be configured to function as a Remote Speed Setting or for Load Share / Sync operation. The only difference between these modes is how they affect the speed setpoint. The Remote Speed Setpoint will adjust the speed within the define range such that a 0 V input signal corresponds to the Low limit, and a 5 V input corresponds to a High Limit setpoint (assuming a non-inverted input). If configured as Load Share / Sync, a mid voltage input signal will provide no setpoint bias. Assuming a non-inverted input, a min voltage input will give max negative bias and a max input voltage will give a max positive bias. The bias range is defined as a user-configurable percentage of speed setpoint.

Remote Speed Setpoint Mode

The Remote Speed setpoint input typically operates from 0 to 5 Vdc; however, it can be configured as a ± 3 V input. A direct or reverse-acting remote speed setting can be configured, using a normal or inverted input selection. Between 0 and 5 Vdc, the control determines the speed setpoint based on a straight line between the Low Limit and High Limit speed settings configured (see Figure 4-4).



WARNING

It is recommended that the actual engine speed be used to externally verify that the speed command matches the command signal sent. Failure to comply with this recommendation can result in undetected system faults.

Load Share / Sync Operation

When the generator breaker is open, the analog input is used for synchronizing. When the generator breaker is closed, this analog input is used for isochronous load sharing within a generator system. An isochronous load sharing module/synchronizer must be connected to provide the isochronous load sharing/synchronizer functions.

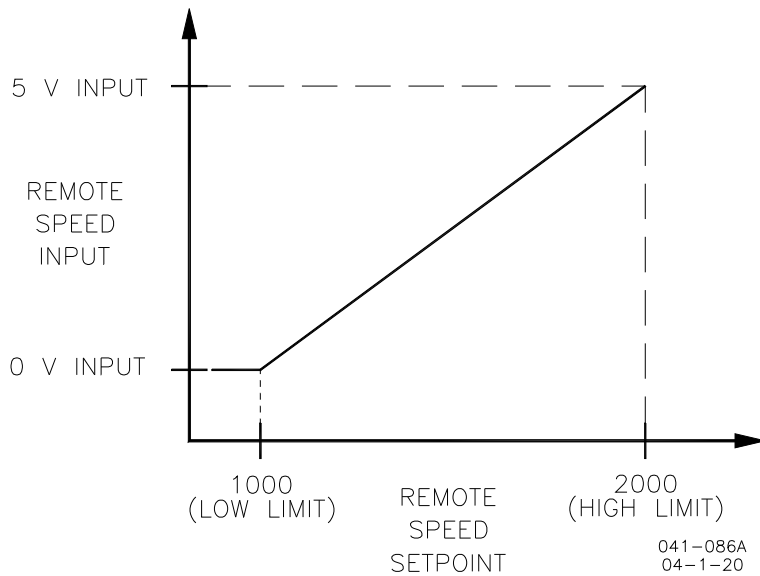

Figure 4-4 Remote Speed Setpoint

The typical Woodward Isochronous Load Sharing/Synchronizer analog input operates from -3 to $+3$ Vdc. This voltage input signal biases the speed setpoint directly and is not ramped like the speed setpoint sources, however, a user-configurable max analog rate is available to provide a max adjustment rate. A positive voltage input increases the speed setpoint. A negative voltage input decreases the speed setpoint. At zero voltage input the speed setpoint is held constant.

The adjustable analog input must be scaled to match the Load Sharing Module/Synchronizer used for these purposes. A DSLC™ load sharing control typically requires a 3% of rated rpm speed setpoint change per volt. An SPM-A synchronizer typically requires a 0.667% of rated rpm speed setpoint change per volt. Other load sharing controls may need different settings.

If configured for Aux1 input, it is programmable as either a 0–5 V input or ± 3 V input. Aux 2–4 inputs are limited to 0–5 V signals only.

The bias percentage is a programmable value. When configured as a 0–5 V input, 5 V corresponds to the full bias percentage in a positive direction; 0 V corresponds to the full bias percentage in a negative direction; and 2.5 V corresponds to no bias (assuming the input is not configured with the invert option). This analog input should be provided by a voltage transmitter via twisted, shielded wire pairs.

When configured as a ± 3 V input, $+3$ V corresponds to the full bias percentage in a positive direction; -3 V corresponds to the full bias percentage in a negative direction (assuming the input is not configured with the invert option). This analog input will be available to interface with Woodward's standard Load Sharing Module. This auxiliary input acts directly on the L-Series speed reference and biases it by a programmable amount up to approximately $\pm 7\%$ in direct proportion to the ± 3.0 Vdc signal. This input will be active only when the L-Series is selected for isochronous operation and should be provided via twisted, shielded wire pairs.

Combination Analog Biasing and Raise/Lower—This feature allows both an analog speed set point and raise/lower setpoint commands. To use this mode requires aux inputs to be configured for a Raise, a Lower, and an Analog input. When a Raise command is activated, the setpoint increases, and when a Lower command is activated, the setpoint decreases. The Analog input is selected when both the Raise and Lower inputs are activated.

General Speed Setpoint Comments—If Idle/Rated is configured, the selection of idle setpoint has priority over the raise/lower and analog setpoints. The idle setpoint must be unselected (rated setpoint selected) to activate the raise/lower and analog setpoints. If configured, the analog setpoint has priority over the rated setpoint. If the analog setpoint is selected when the idle/rated input is switched to the rated position, the setpoint will ramp to the analog setpoint rather than the rated setpoint.

Speed Control Dynamics

The control algorithms used in the L-Series control are designed specifically for reciprocating engine applications. The L-Series speed control offers a powerful set of dynamics that closely match a wide variety of fuel delivery systems and applications. The following configuration choices are offered.

Rated Dynamics

If configured for Rated Dynamics, the gain remains constant as entered and does not vary with engine speed or load. These are simplest dynamics and suit most constant speed applications. Rated dynamics are typically used on engines that operate continuously at rated speed or on variable speed engines that tend to be stable at all speeds with constant dynamic settings.

Idle/Rated Dynamics

If configured, Idle/Rated Dynamics vary the gain with engine speed. Idle gain applies when operating at idle speed. Rated gain applies when operating at rated speed. The gain varies linearly at intermediate speeds and is limited by the idle and rated gain setting at speeds below idle and above rated. Idle/Rated dynamics are useful for variable speed engines that tend to be less stable at idle speed with optimum rated speed dynamic settings.

Rated Dynamics Curve

A Rated Dynamics Curve varies the rated gain value with fuel demand (actuator position). Fuel demand is roughly proportional to load but not necessarily in a linear manner. A 5-breakpoint gain curve is provided to map gain versus fuel demand. Gain is applied linearly between breakpoints. A common gain setting is also provided to shift all gain curve gains higher or lower. This gain curve is particularly useful for non-linear fuel systems (such as intake butterfly valves).

Idle/Rated Dynamics Curve

When using an Idle/Rated Dynamics Curve, gain varies with both engine speed and fuel demand (actuator position). Two separate 5-breakpoint gain curves are provided to map gain versus fuel demand. The Idle Gain Curve applies when the engine is operating at idle speed. The Rated Gain Curve applies when operating at rated speed. The gain varies linearly at intermediate speeds and is limited by the idle and rated gain curve settings at speeds below idle and above rated. Separate common gain settings are provided for each curve to shift all gain curve gains higher or lower. Idle/Rated Dynamics Curve is useful for non-linear fuel systems that tend to be less stable at reduced speed and load operation with optimum rated dynamic curve settings.

For all dynamic configurations the Integral and Derivative settings are constant and do not vary with either engine speed or load.

Cold Start Timer

In demanding genset applications that require 'G3' performance but are also intolerant of cold start instability, the L-Series control offers a cold start timer function that sets the gain of the control to a lower-than-normal value until a programmable amount of time expires. This gives an engine time to warm up slightly before switching to a normal gain value. The cold start timer can be bypassed by programming a time of 0 seconds.

Dual Gain Settings

Gain Window and Gain Ratio settings further modify the applied gain. These Dual Gain Dynamic settings can improve both steady state and transient load performance by automatically switching between two gain settings. A low gain setting is applied during steady-state operation. A high gain setting is applied during load transients. Dual Gain Dynamics are available for all gain configurations.

During steady-state loaded operation, the control uses the primary gain setting (rated gain, idle /rated gain, etc.). In this region, gain is set to prevent the control from responding to minor speed fluctuations inherent with reciprocating engines. This essentially eliminates harmful jiggle of the actuator output and the fuel system linkage during steady-state loaded operation.

During load transients, should the speed error exceed the adjustable Gain Window width, the primary gain setting is multiplied by the gain ratio setting to temporarily increase the applied gain. This higher gain produces a faster fuel response to quickly restore engine speed to the speed setting. Speed error is the difference between actual engine speed and the engine speed setting. The primary gain setting is restored once the control senses a return to steady-state operation (see Figure 4-5). Setting the gain ratio to 1 disables the function.

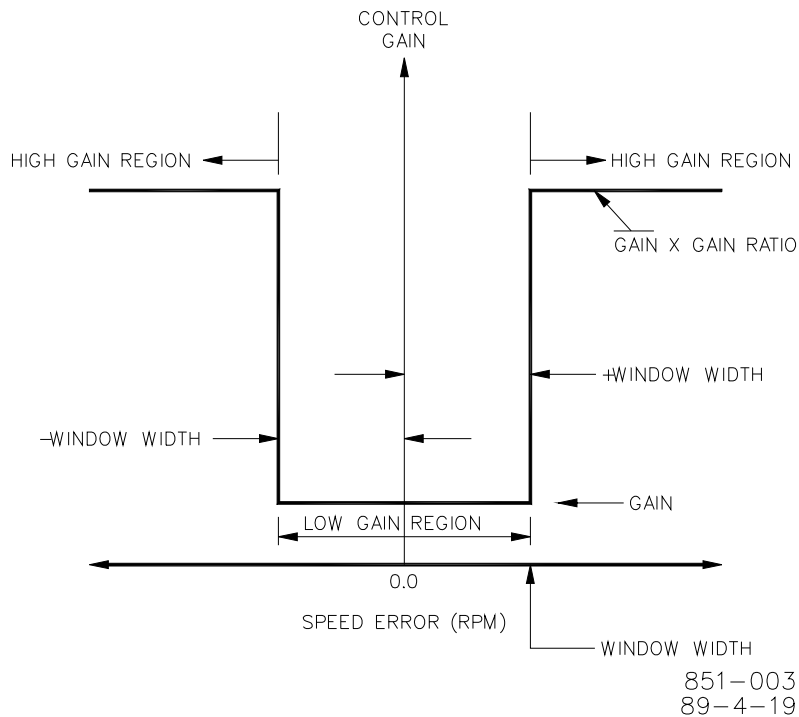

Figure 4-5. Dual Gain Settings

Dual Dynamics

The L-Series speed control also provides a second set of dynamic adjustments (Dual Dynamics) that are selected by activating the 2nd Dynamics discrete input. The control must be configured for Dual Dynamics to make these settings available. Two sets of dynamics are useful for engines where operating modes change, such as in dual-fuel or in island/parallel generator applications. Delay settings are available to delay switching dynamics when the 2nd Dynamics discrete input changes state.

Start Fuel Limiting

The Start Fuel Limit (SFL) is an adjustable limiter on the fuel demand that prevents overfueling during engine starting. Two configurable start fuel limiters are available:

- Single Start Fuel Limit
- Dual Start Fuel Limit

The single Start Fuel Limit is suitable for most applications. With this configuration, the fuel demand immediately switches to the adjustable SFL1 Limit setting when the engine is cranking at the adjustable Start1 Speed setting. The SFL1 Limit is removed and Runtime Fuel Limiting is activated once the engine accelerates to the Run Speed. At the Run Speed the fuel is controlled by the speed control setpoint and ramping functions. The Run Speed setting must be set below the speed reached with the SFL1 Limit setting. See Figure 4-6.

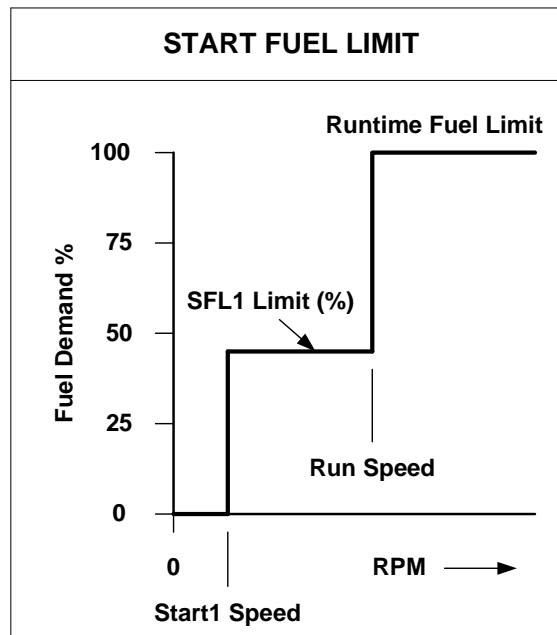

Figure 4-6. Single Start Fuel Limit

The Dual Start Fuel Limit is appropriate for engines that need a rather high fuel setting to start the engine, but a much lower setting immediately thereafter to minimize speed overshoot, black smoke, or prevent an overspeed shutdown. The start sequence will work the same as with only one start fuel setting, but once engine speed is above the Start2 Speed setting, the fuel demand starts ramping to the SFL2 limit at the configured actuator ramp rate.

If the ramp rate is set to its maximum value, the change to the second start fuel is nearly instantaneous. This will essentially eliminate the ramp feature. Start2 Speed must be set higher than the Start1 Speed setting. The SFL2 Limit can be set lower or higher than the SFL1 Limit setting. Otherwise, function is the same as the Start Fuel Limit described above. See Figure 4-7.

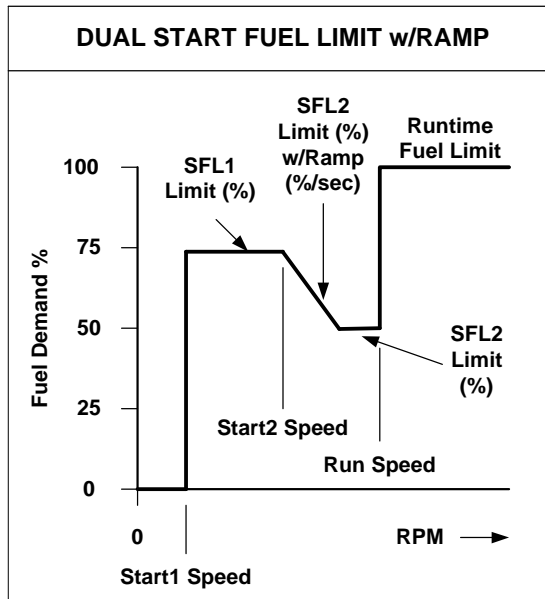

Figure 4-7. Dual Start Fuel Limiters

Runtime Fuel Limiting

The Runtime Fuel Limit is a maximum position limiter on the fuel demand that prevents overfueling/overloading after the engine has reached the run speed setting. Four configurable options are available:

- Maximum Fuel Limit
- Maximum Fuel Limit with Transients
- Boost (External) Fuel Limit Curve
- Runtime (Speed-based) Fuel Limit Curve

Maximum Fuel Limit

The Maximum Fuel Limit setting places a maximum limit on the fuel demand (actuator position). It is generally adjusted to prevent engine overloading at rated speed or to merely limit fuel delivery to the engine for other situations (such as, to prevent detonation). Adjusting the Max Fuel Limit to 100 percent disables the function.

Transient Fuel Limit

The Transient Fuel Limit setting allows a temporary increase to the fuel demand above the maximum (steady-state) fuel limit setting for a set transient time period. This can improve a load-on transient response by allowing a momentarily higher fuel demand. The fuel limits are restored once the Transient Fuel Limit time period expires. The transient fuel limit cannot be increased above 100 % fuel demand. The Transient Fuel Limit is not active below the Run Speed setting.

Boost (External) Fuel Limit Function

External fuel limit is a software adjustable five-breakpoint curve based on an external transmitter analog input signal. Manifold Air pressure (MAP) is typically used for the external fuel limiter signal. The purpose of the manifold air pressure fuel limiter is to prevent over fueling during loading to significantly reduce black smoke in diesel engine exhaust and unburned hydrocarbons in spark gas engine exhaust. A fuel demand (actuator position) limit is set for each specific air manifold pressure breakpoint.

The limiting value is linear between breakpoints as shown in Figure 4-8. The engineering units for each breakpoint are in percent and user set input units. The limiter must be carefully set since excessive fuel limiting can degrade the loading response. On occasion, exhaust temperature or other engine parameters are used for the external fuel limiting function. The external fuel limiter is not active below the run speed setting. With this mode the Maximum Fuel limit setting is still active.

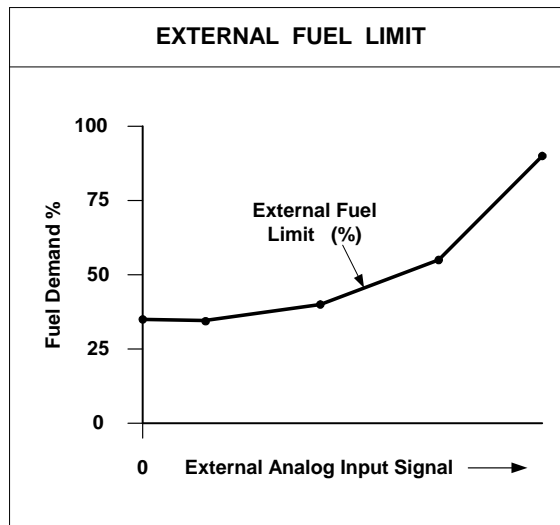

Figure 4-8. Boost (External) Fuel Limit Curve

Runtime Fuel Limit Curve

Runtime Fuel Limit is a software adjustable five-breakpoint curve based on engine speed. The purpose of this fuel limiter is to prevent engine overload during variable speed operation by mapping a fuel limit over the entire speed operating range. The speed input provides the signal for this limiter function. A fuel demand (actuator position) limit is set at each specific engine speed breakpoint. The limiting value is linear between breakpoints as shown in Figure 4-9. The engineering units for each breakpoint are in percent and rpm. Each speed entry must be equal to or higher than the previous entry. The limiter must be carefully set since excessive fuel limiting reduces load-carrying capability. The runtime fuel limiter is not active below the run speed setting.

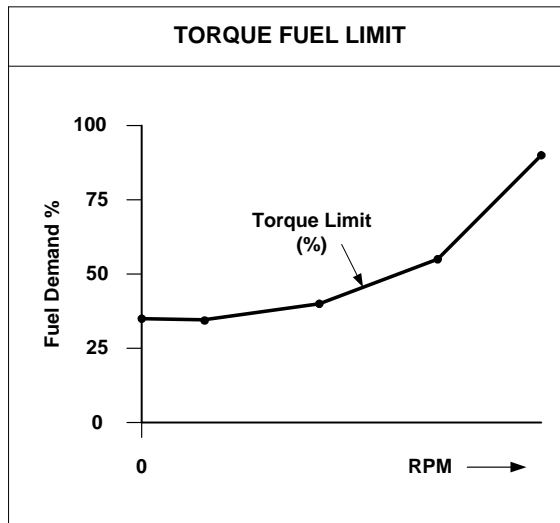

Figure 4-9. Runtime Fuel Limit Curve

Min Fuel Limiting Curve (5418-2193 software only)

The Min Fuel Limit curve is a software adjustable five-breakpoint curve based on engine speed. This function, when active, limits the fuel closing based on engine speed and the curve settings. Take care in setting this function to ensure speed is not forced upward to an unsafe level. In addition, adequate customer-provided overspeed protection is essential.

The minimum fuel limiter is activated by the level of the remote speed setpoint analog input. When this input is above 0.5V for the configured delay time, the function is activated and the min limit is applied. When the input is below 0.5 V, the min limiter function is disabled. When this limiter is active (limiting the position), the L-Series can announce the event with the discrete output.

Temperature Sensing

The L-Series has an on-board temperature sensor to monitor board temperatures and protect the unit from overtemperature. This temperature is monitored and a fault is announced if the set point is exceeded.

Current Limiting based on Temperature

The control provides actuator current limiting based on the electronics temperature. Dependent on board and actuator thermal models, the software reduces current as necessary to avoid conditions that would damage the device due to extreme temperatures.

Current limiting based on temperature begins when the combined current and temperature environment causes board temperatures greater than 117 °C. The limit curve is a linear derate from full current at 117 °C down to zero current at 125 °C. At 125 °C, an OverTemp fault is announced. Depending on the current (actuator torque) and ambient operating temperatures, the unit may never reach a reduced level.

Control Modes

The Service Tool displays the state of the L-Series control, the present mode of the unit. Options include:

- Stopping
- Engine Stopped
- Powered Down
- Start Fuel 1
- Start Fuel 2
- Ramping to Idle
- Running Idle
- Ramping
- Running Rated 1
- Running Rated 2

Stopping

The stopping state indicates the control has a shutdown fault and is driving the output shaft position to the closed position. Once speed has reached zero rpm, the control transfers to the stopped state.

Engine Stopped

In this state, the engine is stopped and the control is ready to begin the start-up cycle if there are no active shutdowns. After the Stopped State Delay, the holding current is applied to the actuator to limit the current draw and prevent battery drain.

Powered Down

In this state, the actuator position control is turned off and the holding current is applied to the actuator to limit the current. This state is only used if the engine is stopped and the run enable discrete input is not active.

Start Fuel 1

The Start Fuel 1 state is selected if the engine speed is higher than the Start Speed 1 threshold. In this state, the actuator position is set to the Start Fuel 1 value.

Start Fuel 2

The Start Fuel 2 state is selected if the engine speed is higher than the Start Speed 2 threshold. In this state, the actuator position is ramped to the Start Fuel 2 value. This state is only used if two start fuels are selected.

Ramping to Idle

Indicates the speed setpoint in ramping up to idle speed setpoint during a start sequence. Ramping to idle is only entered if configured to use an Idle / Rated speed set point. This state is selected if the engine speed is higher than the run speed threshold. At the moment this state is entered, the speed setpoint is set to the engine speed and then ramped to the idle set point using the ramp to idle ramp rate.

Running Idle

Indicates the speed setpoint is at the configured Idle speed setting. To leave this state, the rated command must be issued.

Ramping

The ramping state is used to ramp from one set point to another set point. If the setpoint is switched between Idle and Rated or Rated 1 and Rated 2, we will use this state to ramp with the acceleration or deceleration ramp rate. If Raise or Lower are momentarily selected (halt), the ramp will stop and the setpoint will remain at the last position. The setpoint can be adjusted from this point using the Raise/Lower commands. If the halt command is selected when ramping from idle to rated and the setpoint is below the normal adjustment range, the setpoint will continue to ramp and then halt at the minimum setting of the speed adjustment band.

Running Rated 1

Indicates the unit is running at the Rated 1 set point or the changed Rated 1 set point if raise, lower, or analog control is used.

Running Rated 2

Indicates the unit is running at the Rated 2 set point or the changed Rated 2 set point if raise, lower, or analog control is used.

Fault Detection and Annunciation

Faults can be configured to either alarm or shutdown on occurrence. An alarm basically does nothing but annunciate the fault. A shutdown forces the actuator to a predetermined position regardless of the demanded position. The L-Series can be programmed to fail in the cw or ccw direction. When the shutdown condition no longer exists, the L-Series is returned to a non-shutdown state. Faults can be globally set as either latching or non-latching. When set to latching, either a reset command or a power-cycle is required to clear the fault and allow the unit to start again. If non-latching, the fault is automatically cleared without any reset.

Faults

Faults are separated into two categories: Logged Faults and Current Faults. The Current Faults are volatile and reset every time power is applied. The Current Faults annunciate faults that are presently active/detected. All Logged Faults are latched and written to the EEPROM. They must be cleared through the Service Tool.

Faults can be globally configured as either latching or non-latching. This is a general setting that applies to all faults, unless otherwise noted. When configured as non-latching, a Reset is not needed. If latching mode is configured, a Reset or power-cycle is required to clear the fault and resume positioning. A Reset command can be accomplished by opening and closing a Run Enable discrete input (if configured) or using the Service Tool.

A parameter is available to configure each fault to either an alarm or a shutdown. Each fault can also independently be set to change the state of the discrete output. The shutdown action performed is fault-dependent. Some faults are dedicated as alarms or shutdowns and cannot be configured—they are identified as such below.

Each possible fault is described below.

Watchdog Reset

Watchdog Reset is true if a watchdog timer timeout occurred which resulted in a reset of the microprocessor. This is a hard-coded alarm. If detected, the control will attempt to continue normal operation. This fault is always latching, and a reset is required to clear it.

Brownout Reset

Brownout Reset is true if CPU Voltage drops below 4.2 V but not below 1 V. The brownout detect circuit will reset the CPU. This is a hard-coded alarm. If detected, the control will attempt to continue normal operation. This fault is always latching, and a reset is required to clear it.

EEPROM Fail

EEPROM Fail indicates failure or corruption of the internal non-volatile memory. If the CRC is not correct for the EEPROM data, this fault will be set true. This is a hard-coded internal shutdown. If detected, the control output will go limp. This fault is always latching and a reset is required to clear it.

Position Sense Fail

This indicates a failure of the internal Position Sensor. This is a hard-coded internal shutdown. If detected, the control output will drive to the Fail Direction using current control.

Failure levels: >4.75 V and < 0.25 V

Persistence: 650 ms

Voltage Sense Fail

Indicates an out-of-range signal on the input power. Could indicate input power out of range or a fault in the supply voltage sense circuitry.

Failure levels: >33 V and <6.25 V

Persistence: 650 ms

Can be configured as an alarm or shutdown. If configured as a shutdown, the control will drive to Fail Direction (using current control) if this fault is detected. If configured as an alarm, the control will internally default to an assumed 32 V power supply voltage (decreased torque at lower actual voltages) and attempt to continue normal operation if this fault is detected. The value displayed on the Service Tool will show sensed value, not default.

Temp Sense Fail

Indicates a failure of the internal on-board Temperature Sensor.

Failure levels: >150 °C and <-45 °C

Persistence: 650 ms

Hysteresis: 5 °C (<145 °C or >-40 °C to clear)

Can be configured as an alarm or shutdown. If configured as a shutdown, the control will drive to Fail Direction (using position control) if this fault is detected. If configured as an alarm, the control will internally default to 25 °C and attempt to continue normal operation if this fault is detected. The value displayed on the Service Tool will show sensed value, not default.

OverTemp

If the on-board temperature sensor reads above 125 °C, this error will be set. Above 125 °C, the processor can fail in an unpredictable manner, so this fault is recommended as a shutdown. The Current Limiting based on temperature will effectively make the output "limp" by reducing the drive current to zero.

Failure levels: >125 °C

Persistence: 650 ms

Hysteresis: 5 °C (<120 °C to clear)

Can be configured as an alarm or shutdown. If configured as a shutdown, the control will go limp if this fault is detected. If configured as an alarm, the control will attempt to continue normal operation if this fault is detected.

Position Error

Position Error detection logic will indicate a difference between commanded position and actual position exceeded for longer than the set delay. The error magnitude and duration are customer-configurable parameters.

Failure levels: Set by customer variable, $\text{Error} > |\text{PosErrorMax}|$

Persistence: Set by customer variable, Position Error Delay.

Hysteresis: none

Override: Whenever the current is being limited to a factor of 1/2 normal maximum or less. This would be because of high temperature (see section on Temp Sensing and Current Limiting) or a shutdown that causes the output to go "limp".

Can be configured as an alarm or shutdown. If configured as a shutdown, the control will drive to Fail Direction (using position control) if this fault is detected. If configured as an alarm, the control will attempt to continue normal operation if this fault is detected.

Relay Output Shorted

The relay driver is thermally protected against wiring errors. If incorrectly wired, the output will turn off and then set the Error Bit.

Can be configured as an alarm or shutdown. If configured as a shutdown, the control will drive to Fail Direction (using position control) if this fault is detected. If configured as an alarm, the control will attempt to continue normal operation if this fault is detected.

Speed Input Failed

Speed input signal failed indication.

Dedicated shutdown. The control will drive to Fail Direction (using position control) if this fault is detected. The control must return to a safe condition, determined as the powered-down or stopped state, prior to resuming operation.

Failure levels: $< (\text{Start Speed} / 2)$

Persistence: 13.0 ms

Overspeed

Indication that speed was above the configured overspeed level.

Dedicated shutdown. The control will drive to Fail Direction (using position control) if this fault is detected. The control must return to a safe condition, determined as the powered-down or stopped state, prior to resuming operation.

Failure levels: $> \text{Overspeed level configured value}$

Persistence: 6.5 ms

Governing Error High

Indication that speed was above the high error level for longer than the configured delay.

Can be configured as an alarm or shutdown. If configured as a shutdown, the control will drive to Fail Direction (using position control) if this fault is detected. If configured as an alarm, the control will attempt to continue normal operation if this fault is detected.

If faults are set to non-latching, this fault will not automatically reset until the control is return to a safe condition, determined as the powered-down or stopped state.

Failure levels: > Governing Error High configured level
Persistence: Governing Error High Delay configured value

Governing Error Low

Indication that speed was below the low error level for longer than the configured delay.

Can be configured as an alarm or shutdown. If configured as a shutdown, the control will drive to Fail Direction (using position control) if this fault is detected. If configured as an alarm, the control will attempt to continue normal operation if this fault is detected.

If faults are set to non-latching, this fault will not automatically reset until the control is return to a safe condition, determined as the powered-down or stopped state.

Failure levels: < Governing Error Low configured level
Persistence: Governing Error Low Delay configured value

Max Start Timeout

A failure to start indication. Run speed not attained prior to max start timeout. This is a hard-coded shutdown. If detected, the control output will drive to the closed position. The control must return to a safe condition, determined as the powered-down or stopped state, prior to resuming operation.

Failure level and persistence: starting time > configured max start timeout

Run Enable Shutdown

Run Enable discrete input is opened, only active when this input is configured for use. This is a hard-coded shutdown.

Minimum Fuel Limiting (5418-2193 software only)

Indication that the Min Fuel Limit is active.

Can be configured as an alarm or shutdown. If configured as a shutdown, the control will drive to Fail Direction (using position control) if this fault is detected. If configured as an alarm, the control will attempt to continue normal operation if this fault is detected.

Chapter 5. Service Tool

Introduction

This chapter covers the process of installing and servicing the control via the L-Series Service Tool. It is assumed that the control has already been installed on the engine.

IMPORTANT

Many applications are delivered pre-configured, calibrated, and tuned. These units do not require the use of the Service Tool.

Description

The Service Tool software is used to configure, tune, and troubleshoot the L-Series control. This chapter describes installation and use of the Service Tool. It identifies the parameters available that can be viewed. It also provides detailed information on configuring and setting up the L-Series to the customer-specific field application.

The Service Tool software resides on a PC (personal computer) and communicates to the L-Series through connector pins 4 and 6. An external RS-232 transceiver is necessary to make communications possible with the Woodward L-Series service tool. A connectivity kit (Woodward # 8923-1061) can be purchased from Woodward to accomplish this.

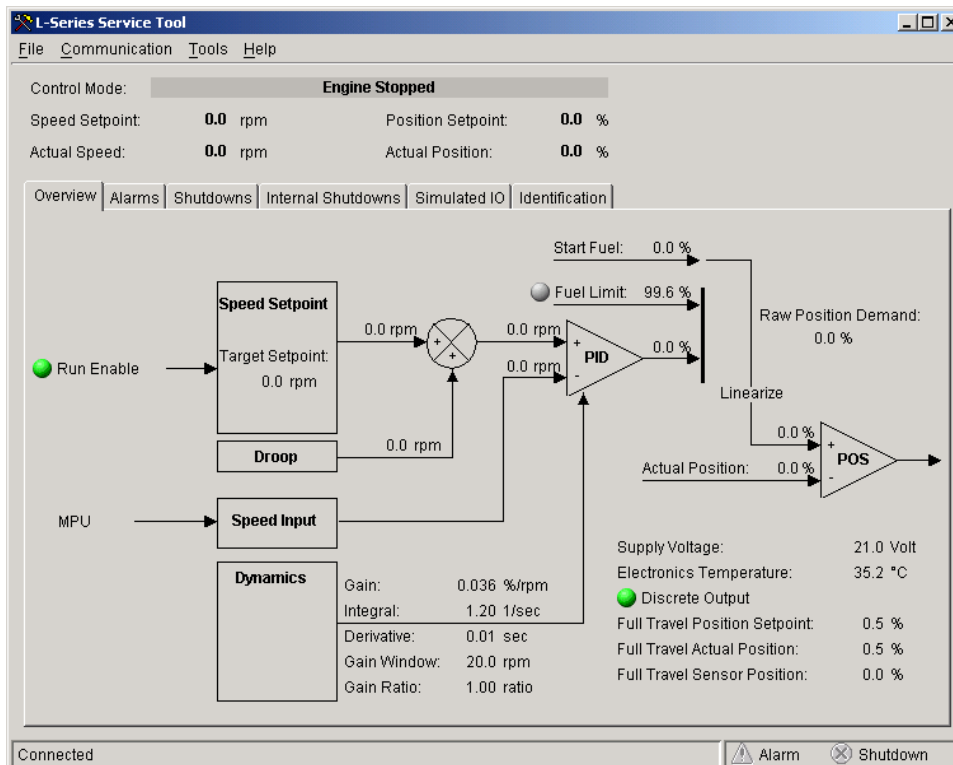

Figure 5-1. Example Service Tool Screen

The following hardware is required to work with the L-Series control:

- PC-compatible laptop or desktop computer* with at least one available serial communications port, and Windows 2000/NT/XP as the operating system.
- Programming/datalink harness as shown in Figure 5-2.

In addition to the hardware, the following are the distributions of tool software needed to communicate with the control:

- Woodward part number 9927-1222, L-Series Service Tool

NOTICE

*—There is a potential for serial port damage when communicating with the L-Series control. This is caused by a difference in ac voltage between neutral and earth ground. If the PC RS-232 port ground is referenced to ac neutral, and the L-Series control is referenced to battery ground (ac earth ground), a large amount of current can be experienced. To avoid this situation, we strongly recommend placing an isolation transformer between the ac outlet and the PC.

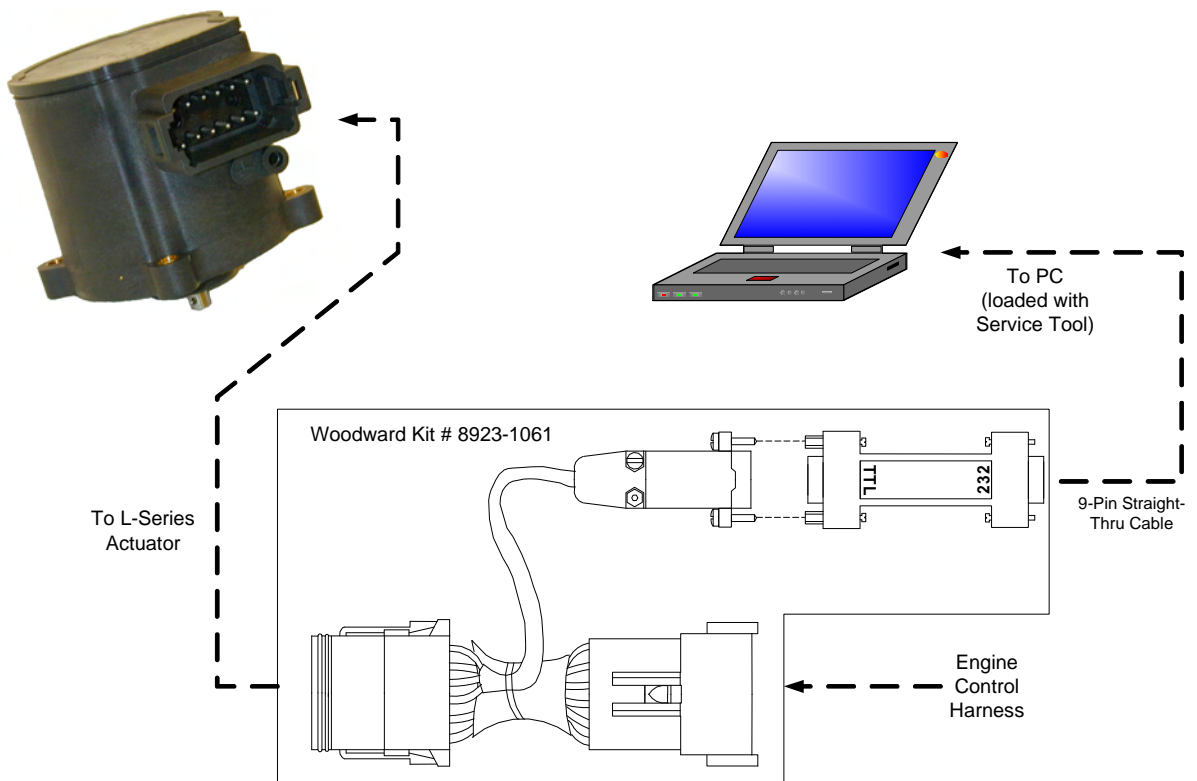

Pinouts Viewed Looking into Control Connector and Computer Connector

Figure 5-2a. Programming Harness Connections

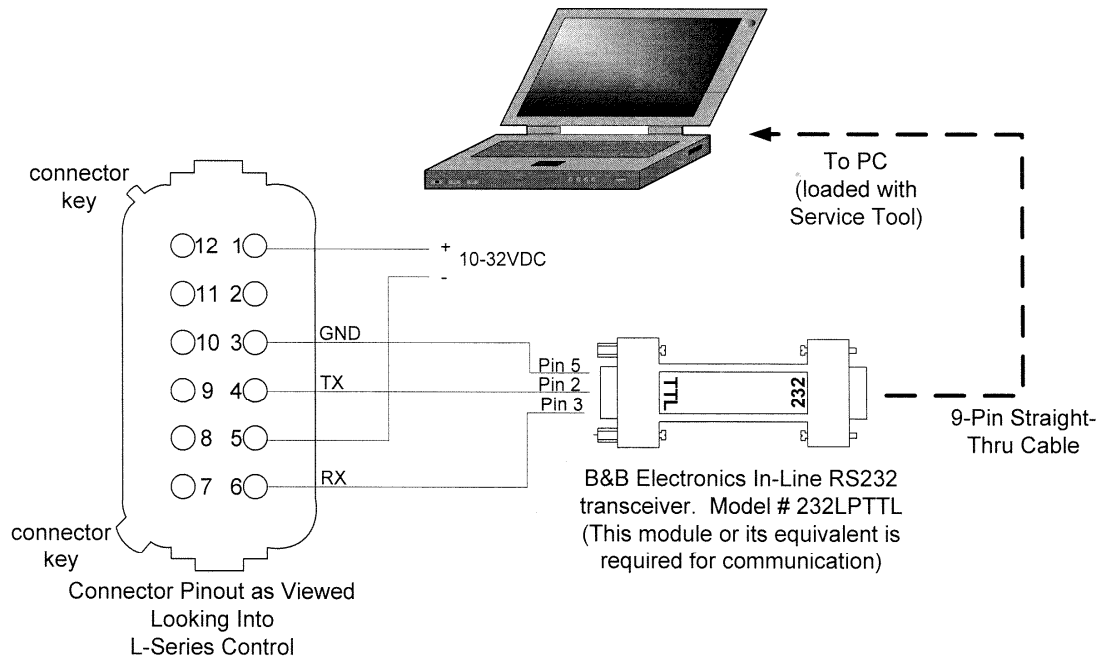

Figure 5-2b. Programming Harness Wiring

Getting Started

Installation Procedure

The Service Tool software can be downloaded and installed from the Woodward internet site (www.woodward.com/software).

What to do Next

After the software is installed, connect a serial communications cable between the RS-232 connections on the L-Series control and an unused serial port on your computer. Run the Service Tool program and select the appropriate comm port. Once connected to the control, the status bar will display 'connected' and the Service Tool screen will populate with monitor parameters.



WARNING

An unsafe condition could occur with improper use of these software tools. Only trained personnel should have access to these tools.

Service Tool Help

More help on using Service Tool is available and included with the installation of the Service Tool product. Service Tool Help can be accessed from the Service Tool 'Contents' drop-down window selection under the Help menu located on the Main Window.

Software Version Identification

The Service Tool software version can be found by selecting 'About' under the Help menu. The software version is identified as the 'Software Part Number' on the Service Tool screen. The Service Tool and Control must be connected to view this information. Refer to this version information in any correspondence with Woodward.

Service Tool Security

Various levels of security are available to protect application settings. One password is available which provides the ability to inhibit tampering of control settings. The individual protection settings include a general password protection on configuration reading (from the control), configuration loading (to the control), position calibration, position PID tuning, and speed PID tuning.

Monitoring the Driver

The Service Tool has six different tab sheets to monitor driver parameters. The tab sheet screens include:

- Overview (see Figure 5-3)
- Alarms (see Figure 5-4)
- Shutdowns (see Figure 5-5)
- Internal Shutdowns (see Figure 5-6)
- Simulated I/O (see Figure 5-7)
- Identification (see Figure 5-8)

Each screen will display the L-series control mode, actual speed, speed setpoint, position setpoint, and actual position values.

Control Mode

Displays the state of the L-Series control, the present mode of the unit. Options include:

- Powered Down
- Engine Stopped
- Stopping
- Start Fuel 1
- Start Fuel 2
- Running Idle
- Ramping
- Running Rated 1
- Running Rated 2
- Ramping to Idle

Speed Setpoint

Displayed value of the speed setpoint - in rpm.

Actual Speed

Displayed value of the actual speed – in rpm.

Position Setpoint

Displayed value of the position demand - in percent.

Actual Position

Displayed value of the actual position - in percent.

Status Bar Indications

At the bottom of the Service Tool window is a status bar. The status bar has two sections. The bottom left section displays communication status and bottom right section displays alarm & shutdown status.

Communication Status

This section of the status bar shows the status of communication between the service tool and the L-Series.

- **Connected**—The Service Tool is connected to and communicating with the driver.
- **Not Connected**—The Service Tool is not connected to the driver.
- **Connecting**—The Service Tool is attempting to connect to the driver. This message is displayed when Connect is selected from the Communications menu or when attempting to re-establish communication to the driver. If the connection is lost it will continuously attempt to re-connect.

Alarm Status

One or more alarms on the Alarms screen is active.

Shutdown Status

One or more shutdowns on the Shutdowns or Internal Shutdowns screen is active.

Overview Parameters Screen

To monitor the overview parameters, go to the Overview page on the main window. This screen dynamically populates based on the unit's configuration. If a function is not programmed, then it will not appear.

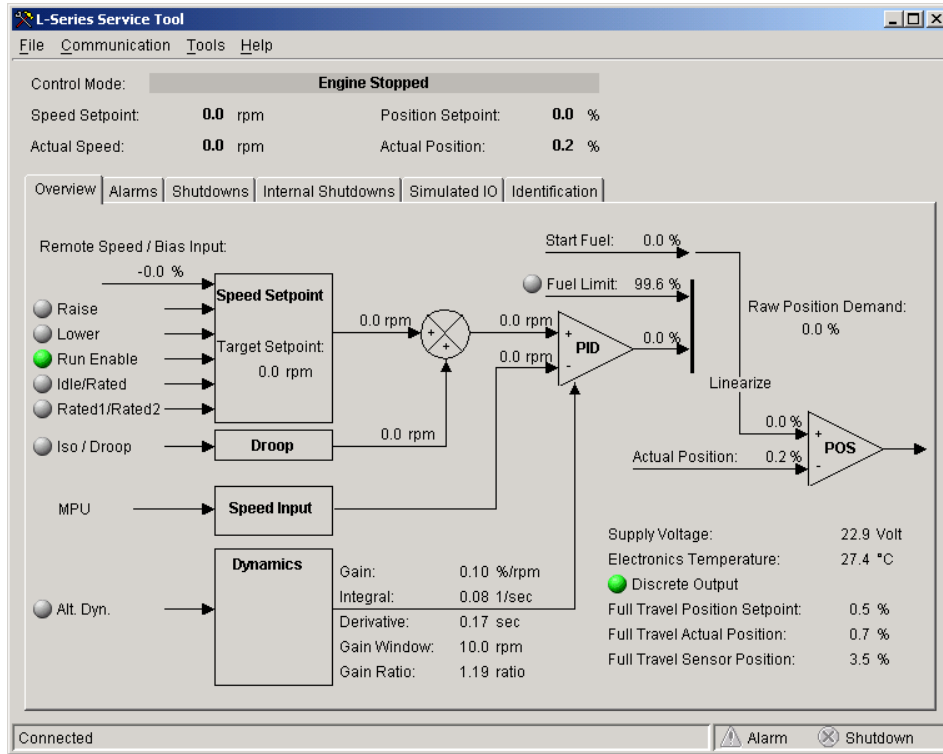

Figure 5-3a. Service Tool—Overview Tab

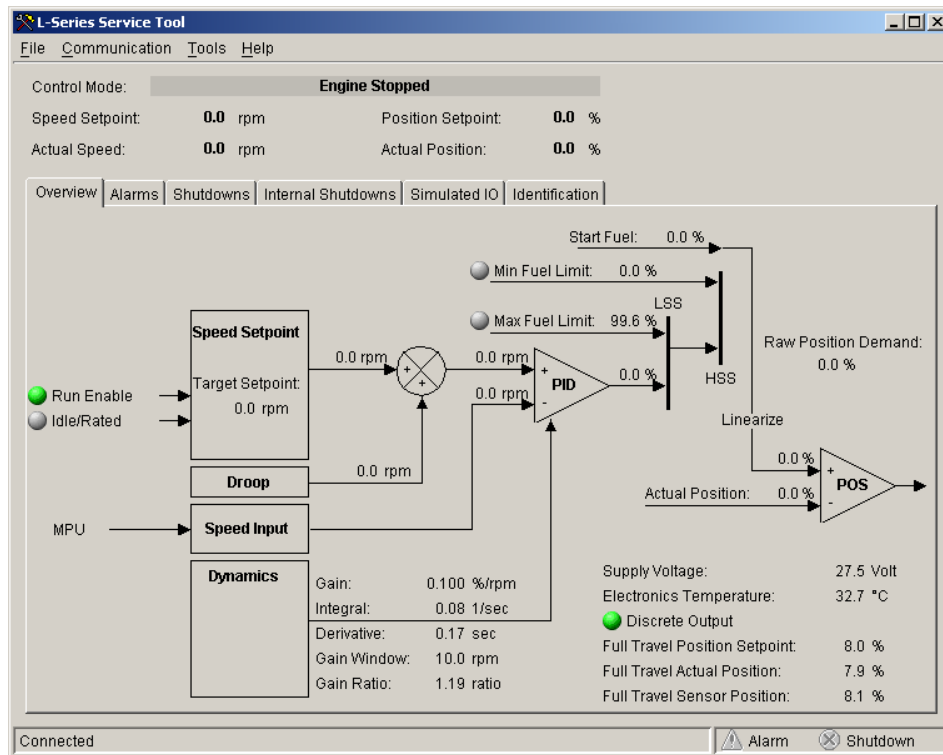

Figure 5-3b. Service Tool—Overview Tab (5418-2193 software only)

Supply Voltage

Displayed value of the input power, in volts, as read by the processor.

Electronics Temperature

Displayed value of the electronics temperature sensor, in degrees Celsius, as read by the processor. The temperature sensor is physically located between the electronics module and the LAT motor.

Discrete Output

On/Off status of the discrete output command. The indicator is illuminated when the channel is commanded to ON and grayed-out when the command signal is OFF.

Full Travel Position Setpoint

Indication of the position setpoint in terms of total overall unit travel. Useful if a less than full-travel user-calibrated range is used.

Full Travel Actual Position

Indication of the actual position in terms of total overall unit travel. Useful if a less than full-travel user-calibrated range is used.

Full Travel Sensor Position

Indication of the position in terms of total overall unit travel before linearization. This value will match the TPS output.

Shutdown and Alarm Indications

The Shutdown and Alarm screens display the status of both active and logged fault conditions. The logged indications provide a history of events even after the unit has been power-cycled or run again.



Indicates a logged alarm condition.



Indicates an active alarm condition.



Indicates a logged shutdown condition.



Indicates an active shutdown condition.

An active fault is one that is currently active or latched in the control. The latching/non-latching faults configuration setting factors into this indication. If the fault is latching, then an active fault could either be one that is still present or one that occurred but has not been reset. Latched faults can be cleared by cycling power on the L-Series control or by selecting the 'Reset Alarms and Shutdowns' button on any of the Alarm or Shutdown screens.

A logged fault is one that occurred but is no longer currently active or latched in the control. Logged faults are permanently cleared by selecting the 'Reset Logged Alarms and Shutdowns' button on any of the Alarm or Shutdown screens.

Alarms Screen

To monitor the alarm conditions, go to the Alarms page on the main window. The values displayed on this screen dynamically change with the fault configuration. Refer to Chapter 4 for a complete listing and details of all the faults.

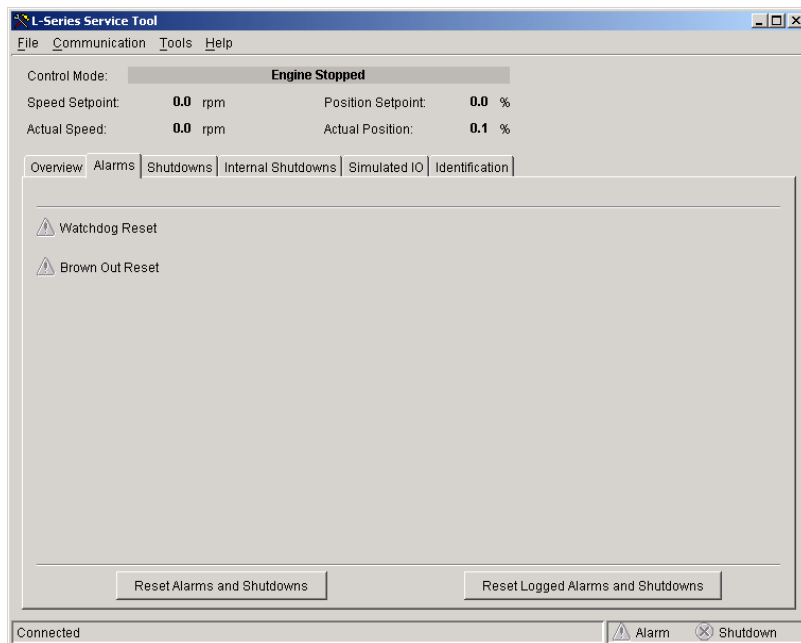

Figure 5-4. Service Tool—Alarms Tab

Shutdowns and Internal Shutdowns Screens

To monitor the shutdown conditions, go to the Shutdowns and the Internal Shutdowns pages (figures 5-5 and 5-6) on the main window. The values displayed on the Shutdowns screen dynamically change with the fault configuration. Refer to Chapter 4 for a complete listing and details of all the faults.

A reset command is available on these screens to clear any current alarms, if they are latched on. If a fault condition occurred but is no longer present, it will remain as a logged fault until cleared. The 'Reset Logged Alarms and Shutdowns' command will clear all logged faults.

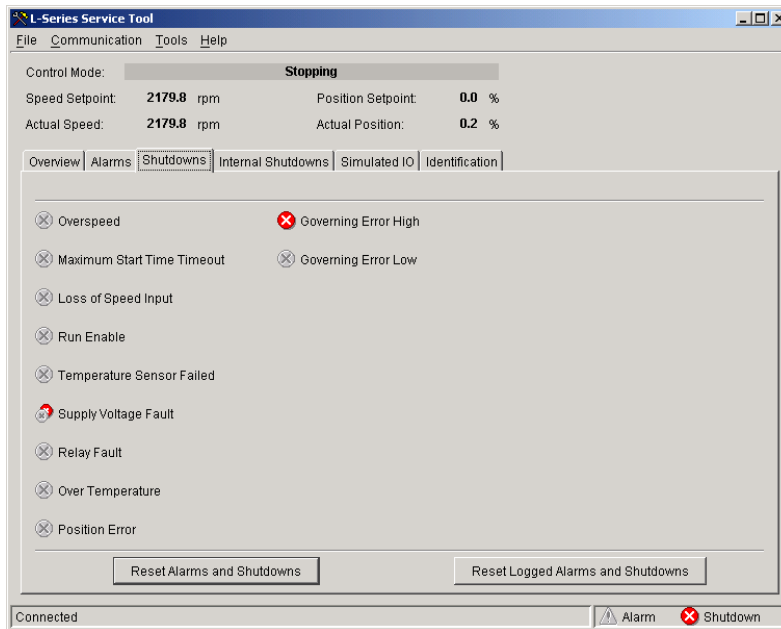

Figure 5-5. Service Tool—Shutdowns Tab

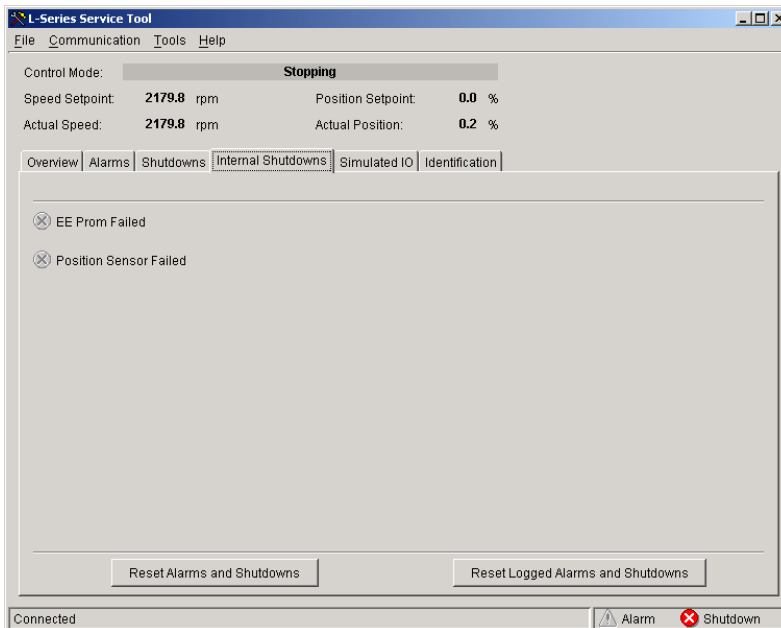

Figure 5-6. Service Tool—Internal Shutdowns Tab

Simulated I/O Screen

While communicating to the service tool, Aux 3 and Aux 4 inputs are not functional since these input pins are used for both Input (analog or discrete) and for serial communications. This screen is provided to facilitate operational testing while connected to the Service Tool. The Aux 3 & 4 Simulated Analog inputs simulate a fixed-value analog input signal, in percentage, and the discrete inputs can be simulated as closed (checked) and open (unchecked) using the Simulated Discrete Input checkboxes.

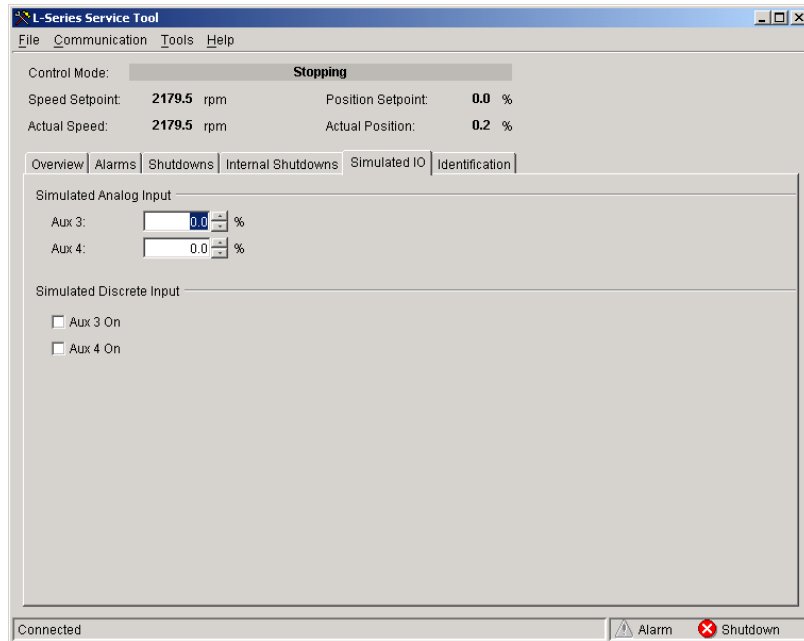

Figure 5-7. Service Tool—Simulated I/O Tab

Identification Screen

To monitor the L-Series product identification, go to the Identification page on the main window. Information displayed includes the part number of the embedded L-Series software, the serial number of the unit, the configuration filename, and the date of the last configuration change.

The Software Part Number identifies the embedded firmware part number and revision. The Serial Number is a Woodward tracking tool and is set at the factory.

The Configuration Identifier displays the first 8 characters of the loaded configuration file, and the Date of Last Configuration Change can be used to track changes to product configuration settings.

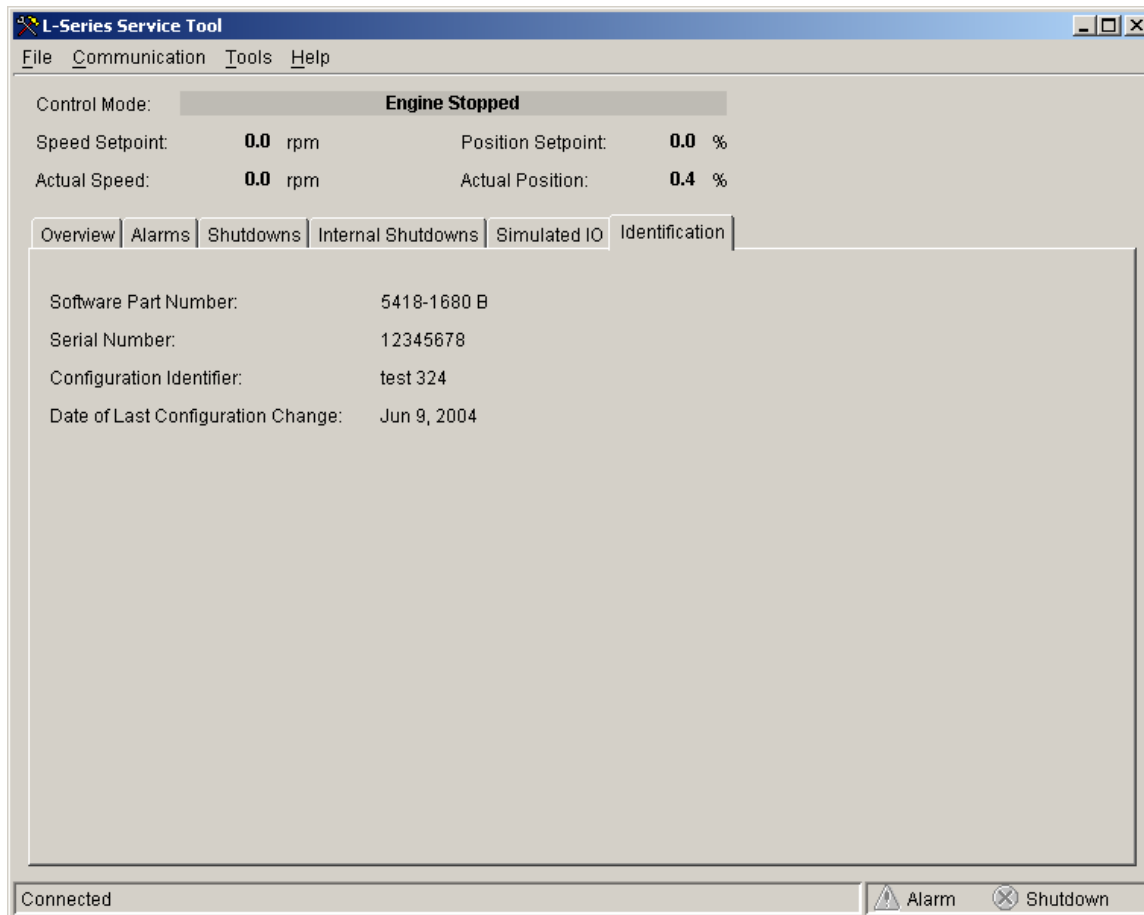

Figure 5-8. Service Tool—Identification Tab

Chapter 6. Configuration

Overview

The L-Series is configured using the Service Tool. Refer to Chapter 5 for Service Tool installation and connection instructions.

The L-Series can be configured either on-line or off-line. On-line configuration can only be performed when the Service Tool is connected to and communicating with the L-Series control. Off-line configuration can be done at any time, however, settings will not take effect until they are loaded into the control.

WARNING

An unsafe condition could occur with improper use of these software tools. Only trained personnel should have access to these tools.

IMPORTANT

Many applications are delivered pre-configured, calibrated, and tuned. These units do not require the use of the Service Tool.

IMPORTANT

Configuration reading and loading can be individually password protected for security purposes. If security is applied, these features will not be accessible without the password.

The current L-Series control configuration settings can be viewed at any time when connected to the control by opening the Configuration Editor (File/Open Control Configuration), assuming password protection is not active. See Figure 6-1.

IMPORTANT

If using dynamics curves or fuel limiting curves, control power must be cycled after loading a new configuration before the new settings will take effect.

OEM Configuration File Data

The OEM can save configuration file specific data with the service tool by selecting Properties under the File menu pull down. This is a text field and can be used to store data such as:

- Customer
- Engine Type
- Application Type
- Notes

Configuring the Unit—On-Line

Unit configuration is summarized as follows:

1. Open the Configuration Editor Dialog by selecting 'File/Open Control Configuration'.
2. Edit the configuration settings.
3. Load the configuration to the L-Series control.

IMPORTANT

As changes are made to Configuration parameters, they are not used by the driver until a 'load' command is issued. Selecting the 'Cancel' button closes the Configuration Editor and does not make any changes to the driver.

Configuring the Unit—Off-Line

Unit configuration is summarized as follows:

1. Open the Configuration Editor Dialog using the File/New or File/Open options.
2. Edit the configuration settings.
3. Save the configuration to a file. At a later date simply open the configuration and load it into the control.

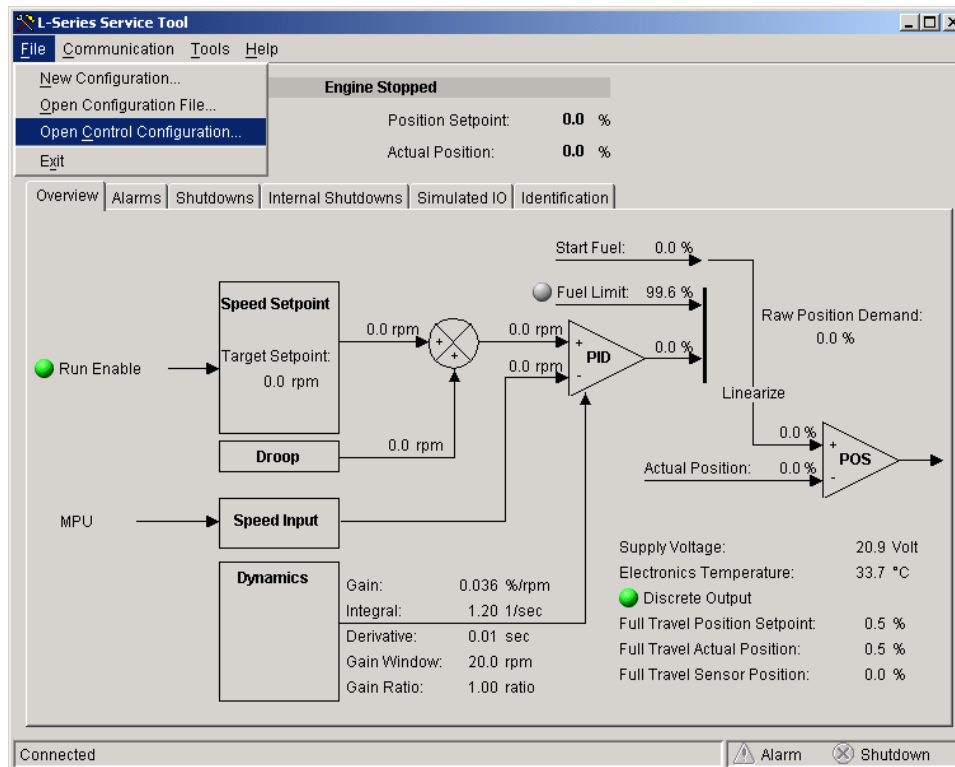

Figure 6-1. Configuration Selection Options

Configuration Parameters

There are 9 different screens that display the configuration settings in the L-Series speed control: Overview, Setpoint, Control, Modifiers, Fuel Limiting, Dynamics, Discrete I/O, Alarm/Shutdown, and Security.

Overview Tab

The overview tab provides speed sensing and position control configuration settings.

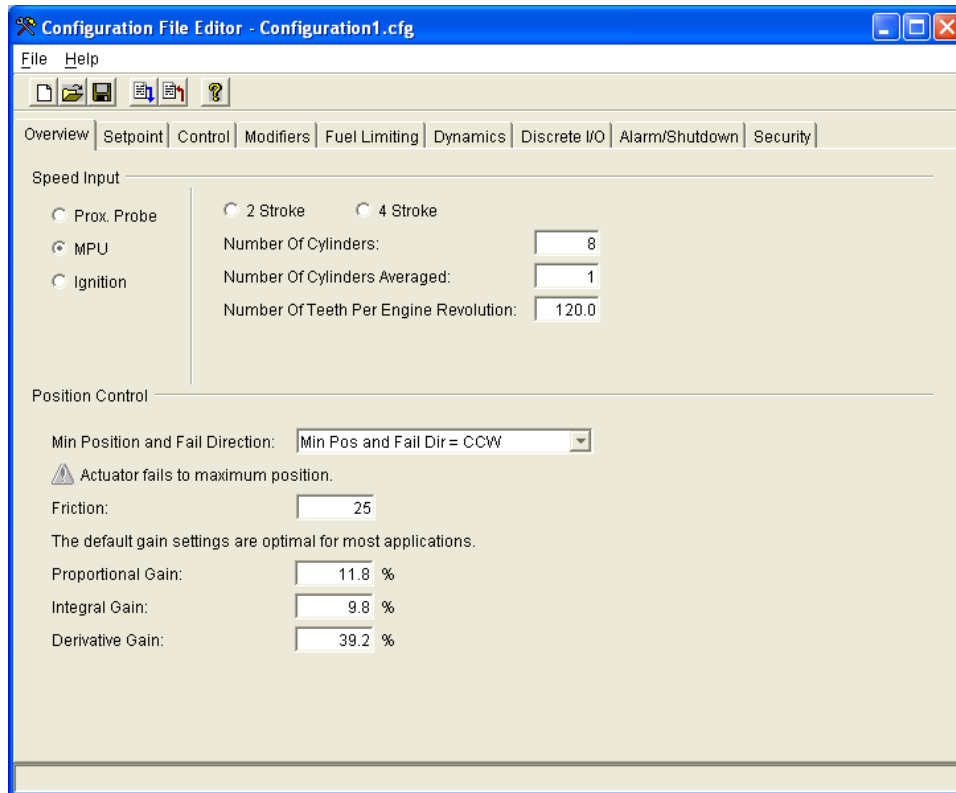

Figure 6-2. Configuration Editor—OVERVIEW TAB

Speed Input Configuration Settings

These settings are used to determine the conversion from speed input pulses to engine rpm, as well as engine torsional filtering. Based on the security settings, the speed input configuration settings (with the exception of the sensor type) can also be modified from the Edit Speed Settings selection under the Tools menu (refer to Chapter 7, Editing of Speed Settings).

Sensor Type

Set to MPU, Proximity Probe, or Ignition. This function requires engine speed pulses present on either the ignition pin input (pin 12) or the MPU pin input (pin 11). The Proximity probe option with internal pull-up is available only with firmware versions 5418-1680 rev D or newer. The firmware version can be found on the Identification tab of the Service Tool.

Engine Type

Set to either 2-stroke or 4-stroke.

Number of Cylinders

Sets the number of cylinders. From the sample table below, select the value that corresponds to the number of crankshaft degrees between ignition pulses.
Allowed values: 1—20

# cylinders	Degrees between pulses (4-stroke engines)	Degrees between pulses (2-stroke engines)
1	720	360
2	360	180
3	240	120
4	180	90
5	144	72
6	120	60
8	90	45

Number of Cylinders Averaged

Sets the number of cylinders to be averaged by the speed sensing algorithm. This setting is used as a filter to minimize the effects of firing torsionals that occur normally in reciprocating engines. A lower value gives less filtering, increases steady-state speed variation but allows for better transient response. A higher value reduces steady-state speed variation but slows transient response. If unsure, set this to either '1' or half the 'Number of Cylinders' for a 4-stroke. On a 2-stroke engine, '1' or 'Number of Cylinders' are good choices.

For uneven firing patterns, 'Number of Cylinders Averaged' should be set to eliminate repeating torsionals.

Allowed values: 1 to 'Number of Cylinders'.

Number of Teeth per Engine Revolution

Sets the number of teeth seen by the speed sensor during one engine revolution. This value is used to calculate the engine speed based on MPU frequency. This value is not displayed when 'Ignition' is configured. Allowed values: 1–720.

Position Control Configuration Settings

The position control controls the position of the shaft based on the position command setting from the speed control logic.

IMPORTANT

For most applications, the default gains do not need to be changed; however, Min Position and Fail Direction should be checked.

Min Position and Fail Direction

Sets the direction for minimum position and fail direction. An alert is displayed (Actuator fails to maximum position.) to warn the user should the fail direction and min fuel direction be opposite.

Friction/Dither Setting

Sets the position control's friction and dither values. This parameter should be set to zero (no effect) while tuning the PID and then increased for optimum response. Increasing this setting increases both the dither amount and a non-linear output component. If unsure, typical values would be between 10 and 25. Allowed values: 0–100.

Proportional Gain

Sets the position control PID's proportional gain. Increased gain corresponds to increased PID output (higher proportional = faster response). This setting can also be dynamically adjusted using the PID Tuning screen. If unsure, a typical value would be 11.8. Allowed values: 0–100%

Integral Gain

Sets the position control PID's integral gain. Increased gain corresponds to increased PID output (higher integral = faster response). This setting can also be dynamically adjusted using the PID Tuning screen. If unsure, a typical value would be 9.8 . Allowed values: 0–100%

Derivative Gain

Sets the position control PID's derivative gain. Increased gain corresponds to increased PID output (higher derivative = faster response). This setting can also be dynamically adjusted using the PID Tuning screen. If unsure, a typical value would be 39.2 . Allowed values: 0–100%

Setpoint Tab

The setpoint tab provides the speed setpoint configuration settings. Based on the security settings, the speed setpoint configuration settings (with the exception of the mode) can also be modified from the Edit Speed Settings selection under the Tools menu (refer to Chapter 7, Editing of Speed Settings).

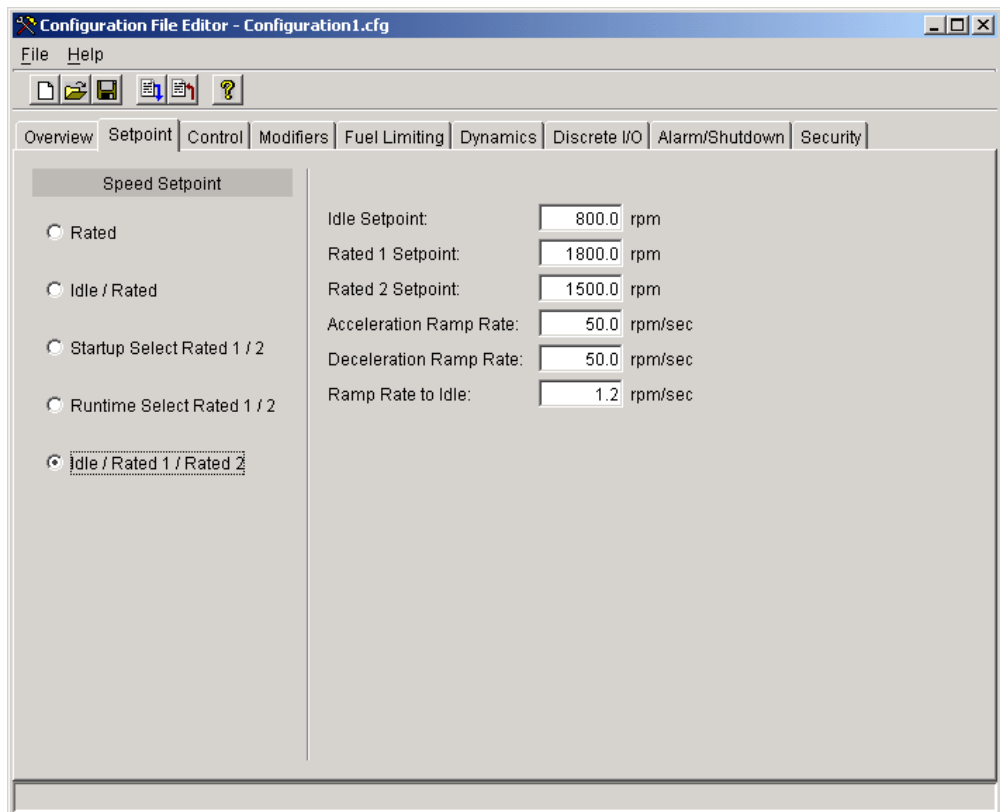

Figure 6-3. Configuration Editor—SETPOINT TAB

Mode

The Mode determines how the speed setpoint will function. This setting determines the display of additional configuration parameters.

Rated—Single speed setpoint control—at rated speed.

Idle / Rated—Two speed setpoint control, idle and rated. Must configure an Idle/Rated discrete input to provide this function (see Discrete I/O tab).

Start-up Select Rated 1/2—Setpoint uses 2 rated speeds, selected on unit start-up. Must configure a Rated2 discrete input to provide this function (see Discrete I/O tab).

Runtime Select Rated 1/2—Setpoint uses 2 rated speeds, selectable at any time. Must configure a Rated2 discrete input to provide this function (see Discrete I/O tab).

Idle / Rated 1 / Rated 2—Three speed setpoint control, idle and rated 1 and rated 2. Must configure an Idle/Rated discrete input and a Rated2 discrete input to provide this function (see Discrete I/O tab).

Idle Setpoint

Sets the Idle Setpoint. Only displayed if Idle is used. Allowed values: 0–4000 rpm, but must be less than Rated.

Rated (or Rated 1) Setpoint

Sets the Rated (Rated 1) Setpoint. Allowed values: 0–4000 rpm, but must be greater than Idle and less than the Overspeed Threshold.

Rated 2 Setpoint

Sets the Rated 2 Setpoint. Only displayed if Rated 2 is used. Allowed values: 0–4000 rpm, but must be greater than Idle and less than the Overspeed Threshold.

Acceleration Ramp Rate

Setpoint ramp rate, in rpm/sec, when increasing to a rated setpoint. Allowed values: 1–1000 rpm/s.

Deceleration Ramp Rate

Setpoint ramp rate, in rpm/sec, when decreasing to a rated setpoint. Allowed values: 1–1000 rpm/s.

Ramp Rate to Idle

Setpoint ramp rate, in rpm/sec, when idle speed is selected. Only displayed if Idle is used. Allowed values: 1–1000 rpm/s.

Control Tab

The control tab provides engine start and stop configuration settings.

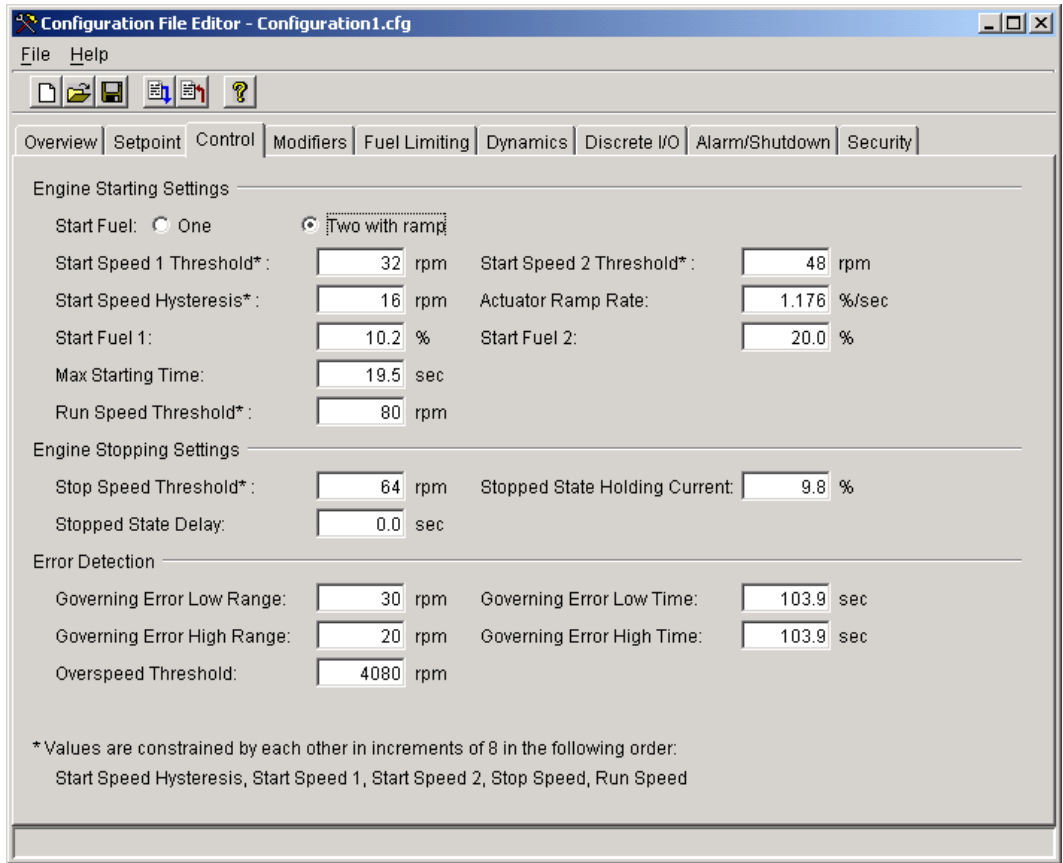
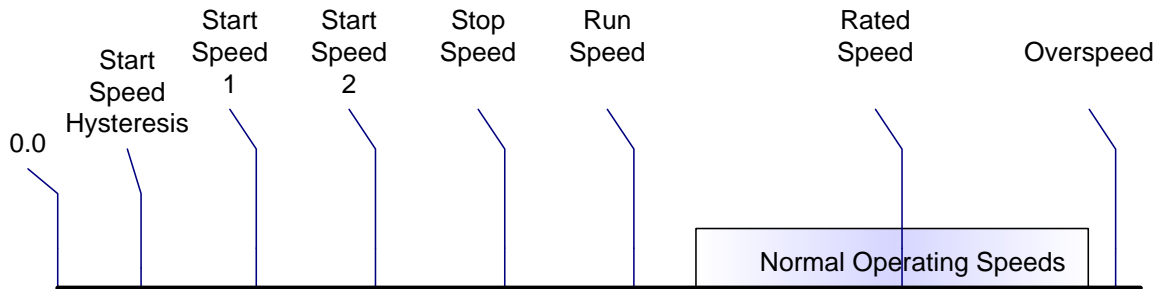

Figure 6-4. Configuration Editor—CONTROL TAB

The L-Series speed settings must follow the following general order.



Starting the Engine

The engine starting sequence will look like this, if no errors are detected:

While in power down, enable the control by the Run enable input. The actuator will go into position control and the control is ready. Start the engine. The engine speed will increase above the Start Speed 1 Threshold, and will go to the Start Fuel position demand. The control is still running open loop, the speed control PID is not controlling to the actuator position. Once the engine speed is above the run speed threshold, the control will switch from start fuel demand to the fuel demand from the speed PID. At this point the unit is in speed control and will control the engine to the speed setpoint. The PID position during starting will be trimmed to the start fuel values, therefore the switch from start fuel to PID control will be performed without a jump in position. If the speed setpoint jumps, the PID position could jump depending on the Gain, Integral, and Derivative settings of the speed PID.

If an error is detected, the control will go to the stopping state. Once the engine speed decreases to zero rpm and the stopping delay is timed out, the unit will be in the stopped state.

Engine Starting Settings

Start Fuel

Set to either one start fuel setting or 2 start fuel settings with a ramp between the settings. A single start fuel is suitable for most applications. With this configuration, the fuel demand immediately switches to the Start Fuel 1 setting when the engine speed has exceeded the Start1 Speed setting.

Dual start fuel configuration is appropriate for engines that need a rather high fuel setting to start the engine, but a much lower setting immediately thereafter to minimize speed overshoot, minimize black smoke, or to prevent an overspeed shutdown.

Start Speed 1 Threshold

Start Speed 1 Threshold is set below the starter speed. Once this threshold is exceeded, the control determines a start is in progress and opens the actuator to the start fuel setting. At this point the governor state changes from 'Stopped' to 'Start Fuel 1'. Typical value is 64 rpm to detect engine cranking.

Allowed values: 16–4000 in 8 rpm increments but must be less than 'Start Speed 2 Threshold' (if used) and less than the 'Stop Speed Threshold'.

Start Speed Hysteresis is provided for the start speed threshold to ensure that a normal amount of variance in engine speed while in the Start Fuel State does not cause the control to enter the Stopping state. After the control has reached the Start Fuel state, it will go to the Stopping state if engine speed drops below the (Start Speed 1 Threshold – Start Speed Hysteresis) value.

Allowed values: 50% of Start Speed 1 to 'Start Speed 1 Threshold' in 8 rpm increments.

Start Fuel 1

Specifies the maximum permitted shaft position when the governor state is 'Start Fuel 1'. Typical value is the same as the full load actuator position.

Allowed values: 0–100%

Start Speed 2 Threshold

Specifies the speed at which the Governor State changes from 'start1' to 'start2.' Typical value is 50% of the lowest speed reference. Only displayed if two start fuel limits are configured.

Allowed values: Must be between 'Start Speed 1 Threshold' and the 'Stop Speed Threshold', in 8 rpm increments.

Start Fuel 2

Specifies the maximum permitted shaft position when the governor state is 'Start Fuel 2'. Only displayed if two start fuel limits are configured.

Allowed values: 0–100%

Actuator Ramp Rate

Specifies the rate, in %/s, the control will move the actuator position from the Start Fuel 1 to the Start Fuel 2 position once the speed exceeds the Start Speed 2 Threshold. If the ramp rate is set to its maximum value, the change to the second start fuel setting is nearly instantaneous, essentially eliminating the ramp feature. Only displayed if two start fuel limits are configured.

Allowed values: 0.235–200%/s

Max Starting Time

This is the maximum time the engine is allowed to stay within the Start Fuel state. This is used to make sure that if there is a problem starting the engine, it will be stopped after a reasonable amount of time.

Allowed values: 0–400 s

Run Speed Threshold

Specifies the speed at which the Governor State changes from 'Start Fuel' to 'running.' Typical value is 90% of the lowest speed reference. If the engine speed is above the Run Speed Threshold, the control will switch to one of the running states and start using the speed control to drive the actuator position demand.

Allowed values: Must be greater than 'Stop Speed Threshold' and less than 4000, in 8 rpm increments.

Engine Stopping Settings**Stop Speed Threshold**

Specifies the speed at which the Governor State changes from 'Stopping' to 'Stopped'. If the engine is stopped by a shutdown, the control will go to the Stopping state and the engine must stop before proceeding to any other state. If the engine is stopped by the Run Enable input, the control will again go to the Stopping state. In this case, however, if engine speed is still above the Stop Speed Threshold, making the Run Enable switch active again will allow the control to go directly back to the running state. Below the Stop Speed Threshold, the control will not allow the engine to restart.

Allowed values: Must be greater than 'Start Speed Threshold' and less than 'Run Speed Threshold', in 8 rpm increments.

Stop State Delay

The Stopped State Delay setting delays the change from the Stopping state to the Engine Stopped state (where the engine can be started again). This is done to prevent starting the engine when it is still turning and the speed input has failed. This time should be set to the time it will take the engine to come to a full stop from the Start Speed 1 Threshold. Above the Start Speed 1 Threshold, the speed signal loss will result in a speed sensor failure, and the engine will not restart until the control is reset.

Allowed values: 0–400 s

Stopped State Holding Current

In the stopped state the control will drive the actuator closed with the Stopped State Holding Current. This is a percent value of steady state current of the actuator. This acts like a return spring (electrical return spring) if the power to the actuator is still there. This will help with diesel pump application or throttle application where it is important to keep the actuator at the closed position if the engine is stopped.

Allowed values: 0–100%

Error Detection Settings**Governing Error Low Range**

Maximum error setting to trigger a Governing Error Low fault.

Allowed values: 0–4000 rpm

Governing Error Low Time

Governing Error Low speed range persistence, in seconds, prior to indicating a fault.

Allowed values: 0–400 s

Governing Error High Range

Maximum error setting to trigger a Governing Error High fault.

Allowed values: 0–4000 rpm

Governing Error High Time

Governing Error High speed range persistence, in seconds, prior to indicating a fault.

Allowed values: 0–400 s

Overspeed Threshold

Specifies the speed level that will trigger an overspeed shutdown fault.

Allowed values: 0–4080 rpm, but must be greater than Rated

Modifiers Tab

The modifiers tab provides droop and speed setpoint biasing configuration settings.

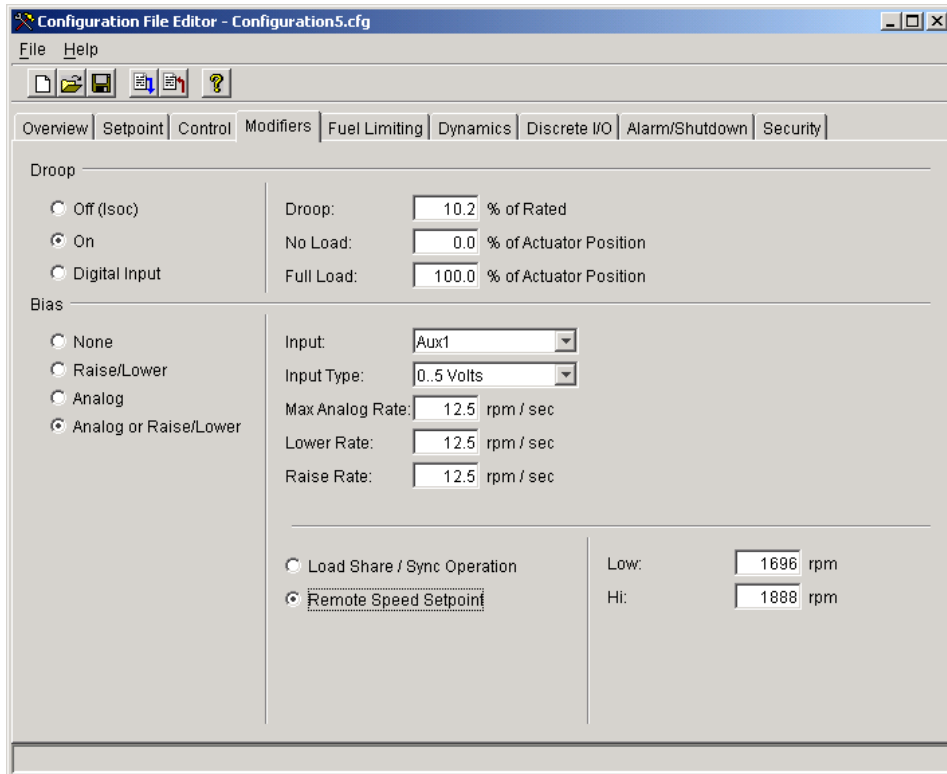

Figure 6-5. Configuration Editor—Modifiers Tab

Droop Settings

Droop Mode

Determines what methods of adjustment of the speed setpoint are to be allowed.

Off—no droop is used, unit to remain in isochronous speed control.

On—actuator position droop is always enabled and active above Idle speed.

Digital Input—actuator position droop is enabled based on the droop discrete input. If this is selected, a digital input must be configured for this function (see Discrete I/O tab).

Droop

Sets the percentage of actuator position droop when droop is enabled.

Allowed values: 0–100%

No Load

Sets the no load actuator position percentage for the droop function. Below this actuator position the droop is zero.

Allowed values: 0% up to the 'Full Load' setting

Full Load

Sets the full load actuator position percentage for the droop function.

Allowed values: From the 'No Load' setting up to 100%

Bias Settings

Bias Mode

Determines what methods of adjustment of the speed setpoint are to be allowed.

None—no biasing of the speed setpoint is used.

Raise/Lower—raise and lower setpoint adjustment commands are used. Must configure raise and lower discrete I/O points to provide this function (see Discrete I/O tab).

Analog—analog biasing of the speed setpoint is used.

Analog or Raise/Lower—a combination of raise/lower and analog biasing are used to adjust the speed setpoint. Must configure raise and lower discrete I/O points to provide this function (see Discrete I/O tab).

Analog Input Selection

Configures the analog input to the AUX hardware input. A 'normal' input is scaled such that 0 V input provides the minimum speed setting and a 5 V input corresponds to the maximum setting as defined by the Bias Limit or Low/High Limit settings. An 'inverted input' selection is available to reverse the direction, resulting in a 5 V minimum and a 0 V maximum speed setpoint command.

Max Analog Rate

Specifies the maximum ramping rates allowed for the speed setpoint Analog adjust function. Only displayed if Analog is configured.

Allowed values: 1–1000 rpm/s

IMPORTANT

It is recommended the Max Analog Rate setting be set to a value that will prevent overshoot and possible overspeed on enabling of the Remote Input.

Lower Rate

Specifies the ramping rate for the speed setpoint Lower function. Only displayed if the Raise/Lower function is configured.

Allowed values: 1–1000 rpm/s

Raise Rate

Specifies the ramping rate for the speed setpoint Raise function. Only displayed if the Raise/Lower function is configured.

Allowed values: 1–1000 rpm/s

Analog Operational Mode

Determines how the analog input range will be applied to the speed setpoint.

Load Share / Sync Operation—biasing is based on a percentage band around the speed setpoint ($\pm 10\%$).

Remote Speed Setpoint—biasing values are set to a specific speed range (1000 to 2000 rpm).

Bias Limit

Specifies the maximum desired speed band possible, as a percentage of Rated, possible with the Raise/Lower Adjust or Analog functions.

Allowed values: 0–100% of speed setpoint

Low Limit

Specifies the lowest desired speed setpoint possible with the Raise/Lower Adjust or Analog functions.

Allowed values: From zero rpm to the 'High Limit'.

High Limit

Specifies the highest desired speed setpoint possible with the Raise/Lower Adjust or Analog functions.

Allowed values: From the 'Low Limit' up to 4000 rpm.

IMPORTANT

Due to a limitation of the Aux1 analog input, the Low Limit may need to be set to a value about 3% below the desired minimum speed setting when using AUX1. Aux 2–4 do not exhibit this limitation.

Fuel Limiting Tab

The fuel limiting tab provides run time and boost fuel limiting configuration settings.

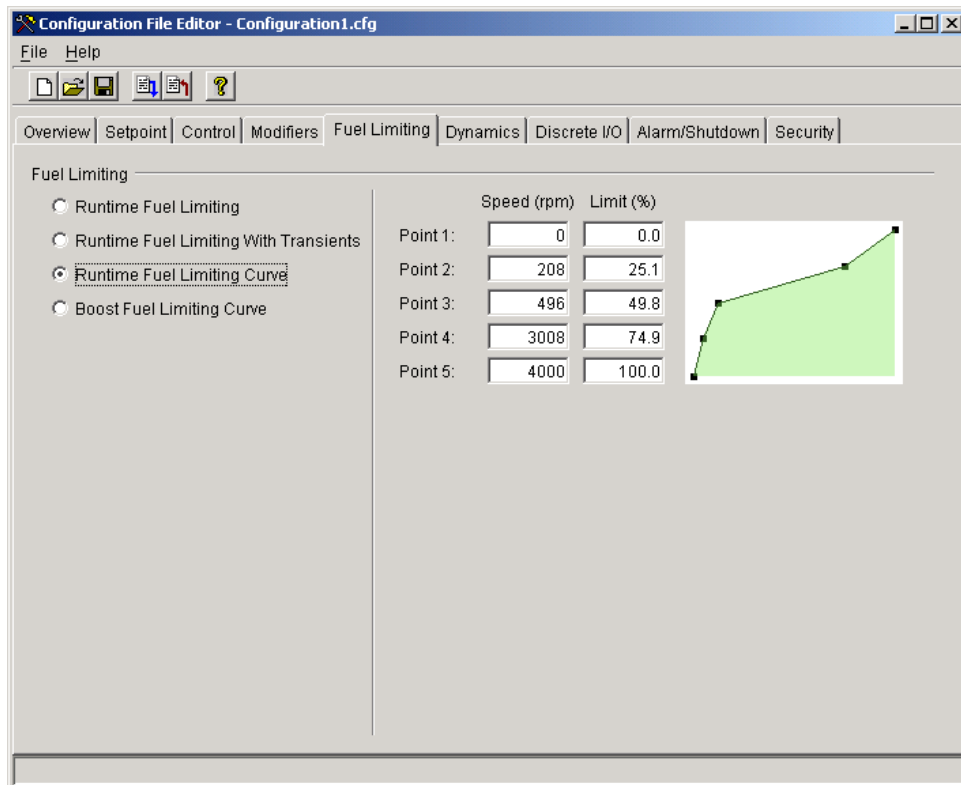

Figure 6-6a. Configuration Editor—Fuel Limiting Tab
(5418-1680 and -2226 software versions)

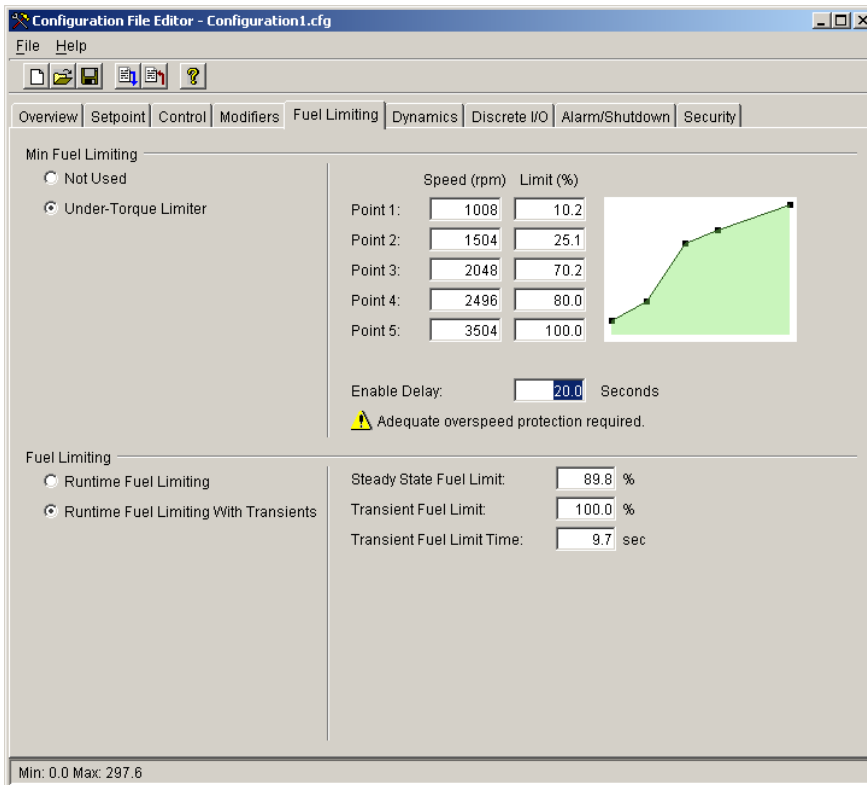

Figure 6-6b. Configuration Editor—Fuel Limiting Tab (5418-2193 software only)

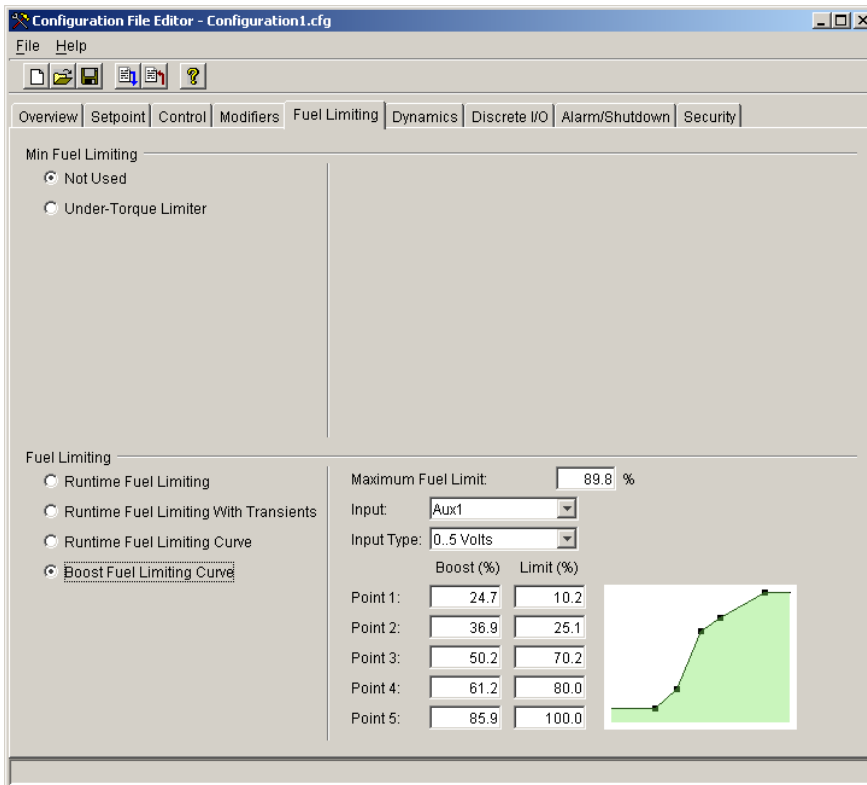

Figure 6-6c. Configuration Editor—Fuel Limiting Tab (5418-2193 software only)

Min Fuel Limiting Settings

Mode

Determines the runtime minimum fuel limiting mode. This setting is only available in software version 5418-2193.

Not Used—no min fuel limiting

Under-Torque Limiter—a speed-based curve will be used to determine the minimum fuel percentage. When this mode is selected, curve selections for Max Fuel Limiting are not available.

Speed (rpm)

Allowed values: Each point [5] must be larger than the previous and less than the next value, in increments of 16 rpm.

Limit (%)

Sets the minimum actuator positions [5] based on the current speed.

Allowed values: 0–100%

Enable Delay (sec)

Determines the delay time before applying the Min Fuel Limiting.

Allowed values: 0–298 sec



WARNING

When using an Under-Torque (Min Fuel) Limit, adequate overspeed protection is required as the Min Limit function will limit the closing of the fuel valve position command.

Max Fuel Limiting Settings

Mode

Determines the runtime fuel limiting mode. The selections available will vary with software version and Min Fuel Limit setting, when used.

Runtime Fuel Limiting—a max actuator position will be used to limit commanded fuel position.

Runtime Fuel Limiting with Transients—a steady-state and a transient fuel limit will be used.

Runtime Fuel Limiting Curve—a speed-based curve will be used to determine the fuel limit percentage.

Boost Fuel Limiting Curve—a speed-based curve will be used to determine the fuel limit percentage.

Maximum Fuel Limit

Sets the maximum permitted shaft position. Only displayed if the mode is set to either Runtime Fuel Limiting or Boost Fuel Limiting Curve.

Allowed values: 0–100%

Steady State Fuel Limit

Sets the maximum permitted actuator commanded position during steady state conditions. Only displayed if the mode is set to Runtime Fuel Limiting with Transients.

Allowed values: 0–100%

Transient Fuel Limit

Sets the maximum actuator position during a transient where the fuel demand is above the Steady State Fuel Limit. Only displayed if the mode is set to Runtime Fuel Limiting with Transients.

Allowed values: 0–100%

Transient Fuel Limit Time

Determines the length of time the Transient Fuel Limit will be applied during a transient. Only displayed if the mode is set to Runtime Fuel Limiting with Transients.

Allowed values: 0–400 s

Speed (rpm)

Allowed values: Each point [5] must be larger than the previous and less than the next value, in increments of 16 rpm.

Limit (%)

Sets the maximum actuator positions [5] based on the current speed.

Allowed values: 0–100%

IMPORTANT

If the Boost or Runtime fuel limiting curve inputs are changed, control power must be cycled before the changes will take effect.

Boost Fuel Limiting Curve Settings

These settings are only displayed if the fuel limiting mode is set to Boost Fuel Limiting Curve.

Analog Input

Configures the boost/map analog input to the AUX hardware input. A 'normal' input is scaled such that 0 V input provides a 0% boost signal and a 5 V input corresponds to a 100% boost signal. An 'inverted input' selection is available to reverse the direction, resulting in a 5 V minimum and a 0 V maximum boost input signal.

If Aux1 input is used, the input can be configured as either 0–5 V or ± 3 V. If configured as ± 3 V, replace 0 V by -3 V and 5 V by $+3$ V in the above discussion.

Input Type

Only displayed if the Input is selected as 'Aux1'. Set to either 0–5 V or ± 3 V.

Boost (%)

Allowed values: Each point [5] must be larger than the previous and less than the next value, in increments of 1.2 percent.

Limit (%)

Sets the maximum actuator positions [5] based on the boost analog input.

Allowed values: 0–100%

Dynamics Tab

The dynamics tab provides speed control dynamics settings. The dynamic settings can also be adjusted from the Edit Speed Dynamics screen during run-time.

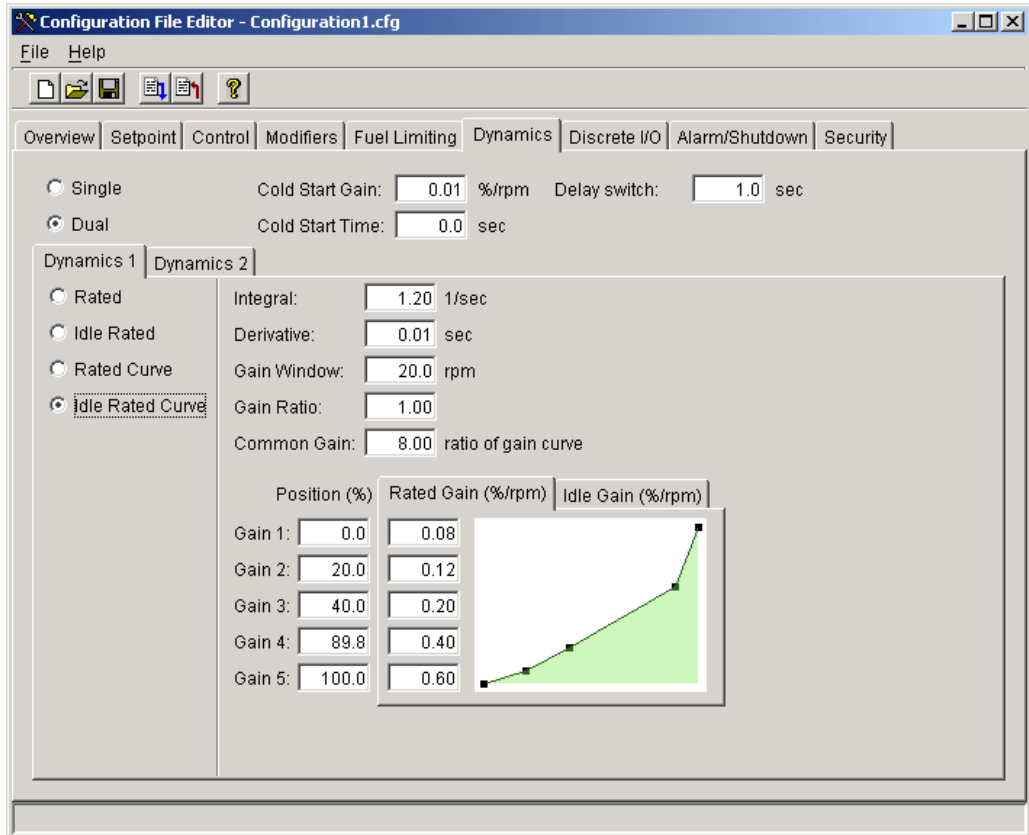

Figure 6-7. Configuration Editor—Dynamics Tab

Dynamics Settings

Overall Mode

Set to Single or Dual dynamics. If 'Dual' is selected, must configure a Dual Dynamics discrete input to provide this function (see Discrete I/O tab).

Cold Start Gain

Sets the gain to be used during a start. Typically this is set to a lower than normal gain value. To disable the Cold Start Gain, set the Cold Start Gain Timer to zero.

Allowed values: 0–0.778 %/rpm

Cold Start Gain Timer

Sets the number of seconds the Cold Start Gain is used during a start. To disable the Cold Start Gain, set the Timer to zero.

Allowed values: 0–300 s

Delay switch (between Dyn 1 and Dyn 2)

The delay, in seconds, before the dynamics actually changes to the selected set (either from dynamics 1 to dynamics 2 or vice versa).

Allowed values: 0–425 s

Mode (Dynamics 1 and 2)

Sets the functional mode for the P-gain term of the PID. This can be individually set for both sets of dynamics, if used.

Rated—a single speed gain term is used which remains constant and does not vary with engine speed or load. These are simple dynamics that suit most constant speed applications. Rated dynamics are typically used on engines that operate continuously at rated speed or on variable speed engines that tend to be stable at all speeds with constant dynamic settings.

Idle Rated—the gain term will be changed linearly between Idle and Rated speed. Idle gain applies when operating at idle speed. Rated gain applies when operating at rated speed. The gain varies linearly between the two settings at intermediate speeds and is limited by the idle and rated gain setting at speeds below idle and above rated. Idle/Rated dynamics are useful for variable speed engines that tend to be less stable at idle speed with optimum rated speed dynamic settings. Must configure an Idle/Rated discrete input to provide this function (see Discrete I/O tab).

Rated Curve—the gain term will be adjusted based on actuator position using a 5-pt curve. Fuel demand is roughly proportional to load but not necessarily in a linear manner. A 5-breakpoint gain curve is provided to map gain versus fuel demand. Gain is applied linearly between breakpoints. A common gain setting is also provided to shift all gain curve gains higher or lower. This gain curve is particularly useful for non-linear fuel systems (for example, intake butterfly valves).

Idle Rated Curve—the gain will be adjusted using both by actuator position and speed. Must configure an Idle/Rated discrete input to provide this function (see Discrete I/O tab).

IMPORTANT

Selection of Dynamics 2 curve options is only allowed if Dynamics 1 is also set to a curve option.

Integral

Speed control PID integral term in repeats per second.

Allowed values: 0–19.16 repeats/s

Derivative

Speed control PID derivative term in seconds.

Allowed values: 0–1.66 s

Gain Window

Speed control PID gain window, in rpm. When the speed error is greater than the window, the Gain is multiplied by the Gain Ratio.

Allowed values: 0–255 rpm

Gain Ratio

Speed control PID gain ratio. When the speed error is greater than the window, the Gain is multiplied by the Gain Ratio. To disable the dual gain window, set the Gain Ratio to 1.

Allowed values: 1–15

Position (%)

Position breakpoints for the gain curve.

Allowed values: Each point [5] must be larger than the previous and less than the next value, in increments of 0.4 percent. Range: 0–100%

Gain (%/rpm)

Sets the gain value [5] based on the position.

Allowed values: 0–0.778 %/rpm

Common Gain

Speed control PID common gain. This setting is a multiplier on the entire gain curve settings. A Common Gain setting of 1 provides no bias.

Allowed values: 0–8

Discrete I/O Tab

The Discrete I/O tab provides discrete input and discrete output configuration settings.

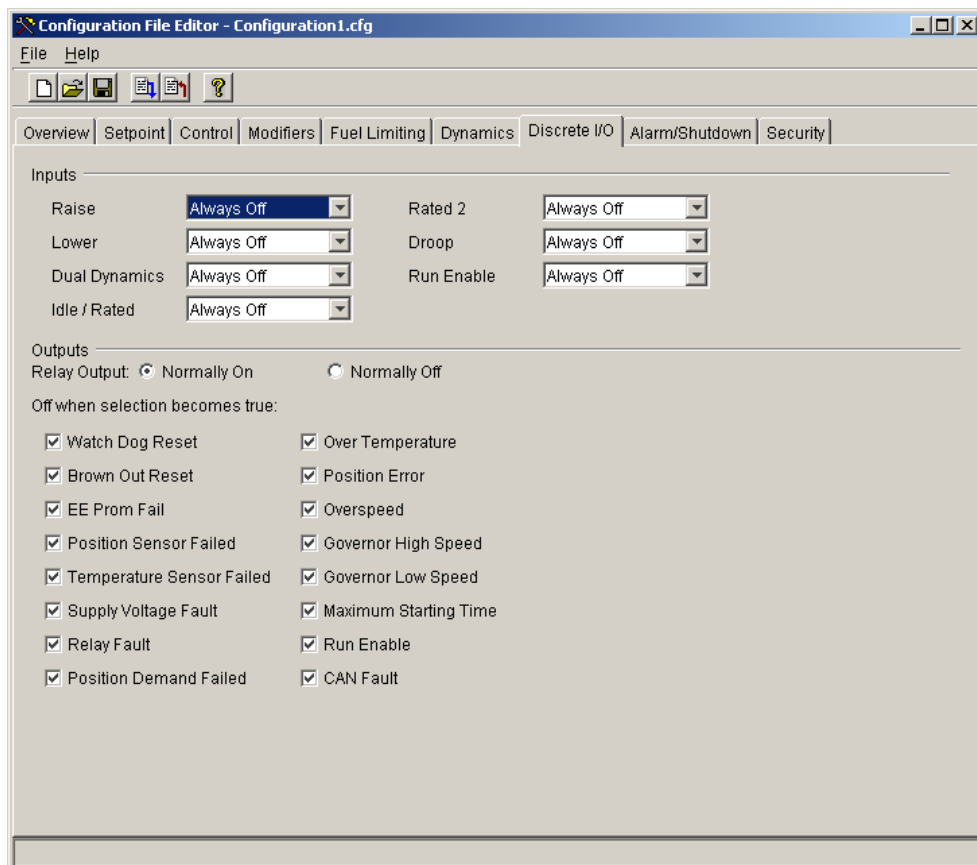

Figure 6-8. Configuration Editor—Discrete I/O Tab

Input Configurations

This section facilitates the mapping of the control functions to the desired Aux input. Options include:

- Always Off
- Aux1 (active closed)
- Aux2 (active closed)
- Aux3 (active closed)
- Aux4 (active closed)
- Aux1 (active open)
- Aux2 (active open)
- Aux3 (active open)
- Aux4 (active open)
- Always On

Any unused function is typically turned off by selecting 'Always Off', the exception to this is the Run Enable which requires an 'Always On' selection or the control will never run.

Selecting 'Active Closed' for a function will activate a function whenever the aux input voltage is above the ON threshold (refer to the Specifications section for On and Off thresholds). Likewise, selecting 'Active Open' will activate the function when the aux input is below the OFF threshold. An "Active Closed" setting is recommended.

Input Configuration Settings

Raise

Select the desired input for this function.

Lower

Select the desired input for this function.

Dual Dynamics

Select the desired input for this function.

Idle / Rated

Select the desired input for this function.

Rated 2

Select the desired input for this function.

Droop

Select the desired input for this function.

Run Enable

Select the desired input for this function.



WARNING

It is recommended that all inputs be configured for the failsafe 'Active Closed' mode, to ensure maximum fault protection.

Output Settings

Relay Output Configuration

The relay output can be configured to one of the following:

Normally On—Sets the relay driver to a normally on mode that turns off for any of the faults selected. This is the preferred, failsafe output configuration.

Normally Off—Sets the relay driver to a normally off mode that turns on for any of the faults selected.



It is recommended that the Relay Output be configured for the failsafe 'Normally On' mode, to ensure maximum fault protection and annunciation. Failure to follow these guidelines could, under exceptional circumstances, lead to personal injury and/or property damage.

Relay Output Fault Selections

The list of faults displayed can be individually selected to activate the relay output. Any of the selected faults will either turn the output off if configured for Normally On or turn the output on if configured for Normally Off.



It is recommended that all faults be configured to activate the discrete output, this ensures maximum fault annunciation.



The selection for Loss of Speed Input is incorrectly shown/listed as Position Demand Failed. This will be corrected in the next Service Tool release.

The 'At Minimum Fuel Limit' selection is only available in software version 5418-2193.

Alarm / Shutdown Tab

The Alarm/Shutdown tab provides alarm and shutdown configuration settings.

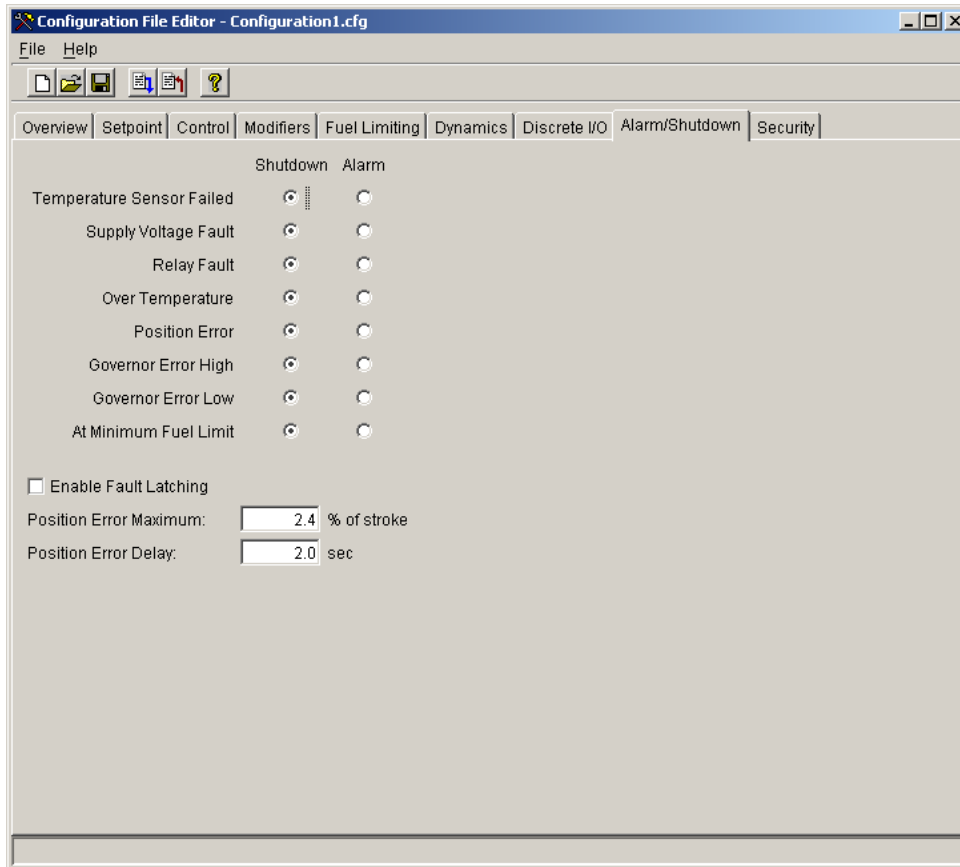

Figure 6-9. Configuration Editor—Alarm/Shutdown Tab

Alarm / Shutdown Fault Settings

Fault Selection (Shutdown or Alarm)

Set the desired action for each of the faults from the list. Setting the selection to a Shutdown will position the output to the configured Fault Direction (see Overview tab). Setting the selection to an Alarm will allow the unit to attempt to continue running. For details on each of these fault conditions, refer to the Fault section in the manual (Chapter 4).

- Temperature Sensor Failed
- Supply Voltage Fault
- Relay Fault
- Over Temperature
- Position Error
- Governor Error High Speed
- Governor Error Low Speed
- At Minimum Fuel Limit (5418-2193 software only)

The following conditions are dedicated shutdown conditions.

- EE Prom Fail
- Position Sensor Failed
- Overspeed
- Max Starting Time
- Loss of Speed Input
- Run Enable

The following conditions are dedicated alarm conditions.

- Watch Dog Reset
- Brown Out Reset



It is recommended that all faults be configured as shutdowns and selecting 'Enable Fault Latching', this ensures maximum fault protection and prevent erratic on/off fault behavior.

Enable Fault Latching

Set to either latching (checked) or non-latching. When set to latching, a reset command or a power cycle must be issued to clear the fault. When non-latching is configured, as the fault condition goes away the control will be ready for operation. The fault log will indicate any faults that have occurred and subsequently cleared.

Position Error Maximum

Sets the magnitude of the position error fault.

Allowed values: 0–100% of stroke

Position Error Delay

Sets the delay that the position error must persist before indicating a position error fault.

Allowed values: 0–10 s

Security Tab

The security tab provides the security configuration settings. To use any security, the Read Configuration security must be configured for use. Once selected, the Security Password must be set (Figure 6-11). One common password is used for all security selections. The password entry is prompted (Figure 6-12) whenever a secured function is selected by the user.

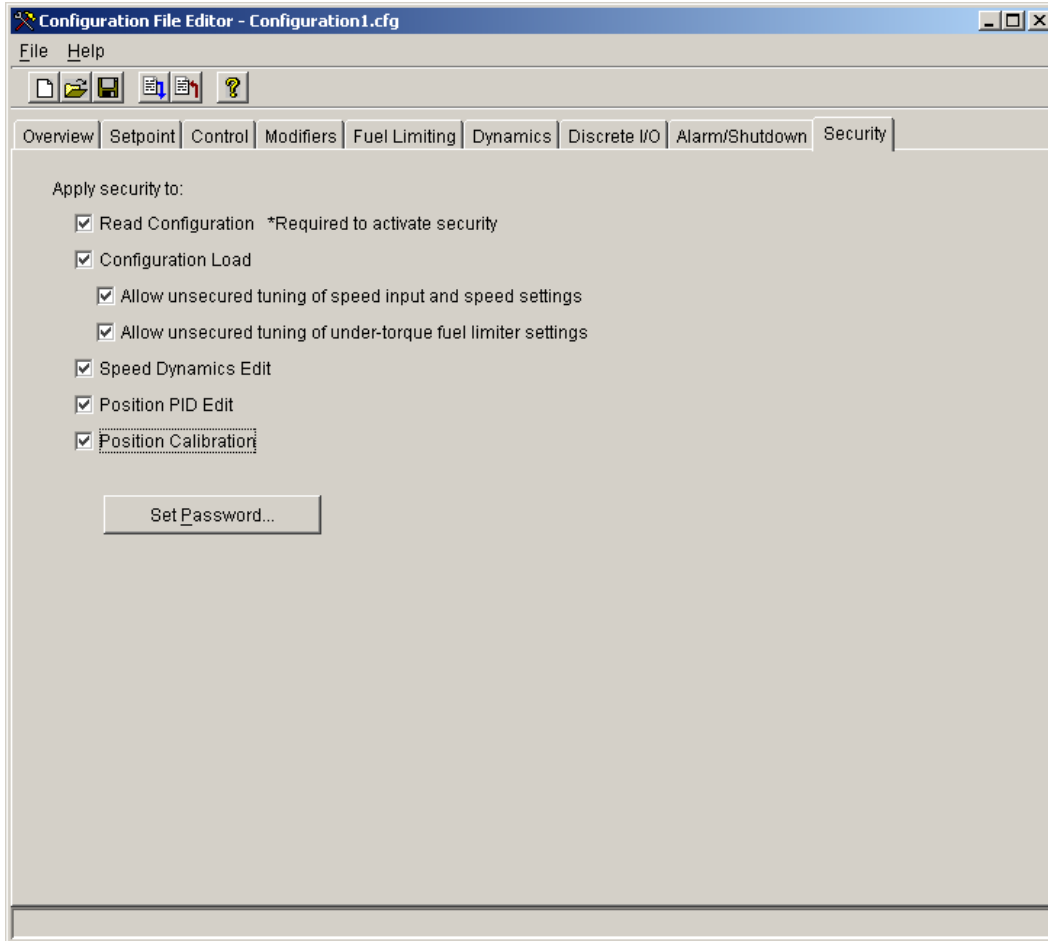

Figure 6-10. Configuration Editor—Security Tab

Security Configurations

All checked features will have the security password enforced prior to allowing the function. Unchecked features will not be prompted with a password.

Read Configuration

When checked, requires a password before the configuration can be read from the L-Series control (protects Open From Control execution).

This is the minimum level of protection and is required in order to use any other security option.

Configuration Load

When checked, requires a password before a configuration can be loaded into the L-Series control (protects Load to Control execution).

Allow unsecured tuning of speed input and speed settings

When checked, allows password-free access to speed and speed setpoint adjustments from the Edit Speed Settings menu item. To use this feature, the Configuration Load security option must be selected.

Allow unsecured tuning of under-torque fuel limiter settings (5418-2193 software only)

When checked, allows password-free access to Min Fuel Limit "Limit" settings from the Tools / Edit Configuration Settings menu item. To use this feature, the Configuration Load security (Security tab) and the Under-Torque Limiter (Fuel Limiting tab) options must be selected.

Speed Dynamics Edit

When checked, requires a password before allowing tuning to the speed PID (protects Edit Speed Dynamics screen).

Position PID Edit

When checked, requires a password before allowing tuning to the position PID (protects Edit Position PID screen).

Position Calibration

When checked, requires a password before the position calibration mode can be entered (protects Manual and Automatic Position Calibration screens).

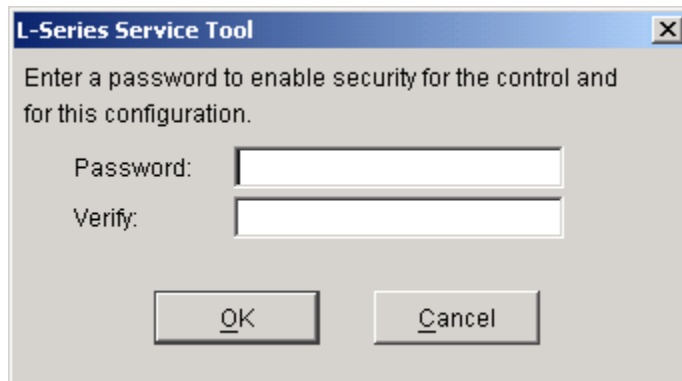

Figure 6-11. Security Tab Set Password Pop-up

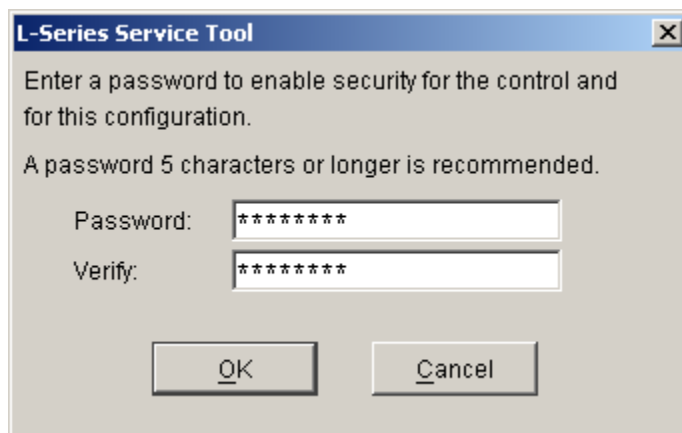

Figure 6-12. Password Entry Prompt

Loading the Configuration (Save)

Select the File/'Load to Control' option from the menu or Blue Arrow icon on the Configuration Editor to load the changes into the control. The L-Series speed must be zero prior to allowing a 'Load' command. This feature can be optionally password protected.

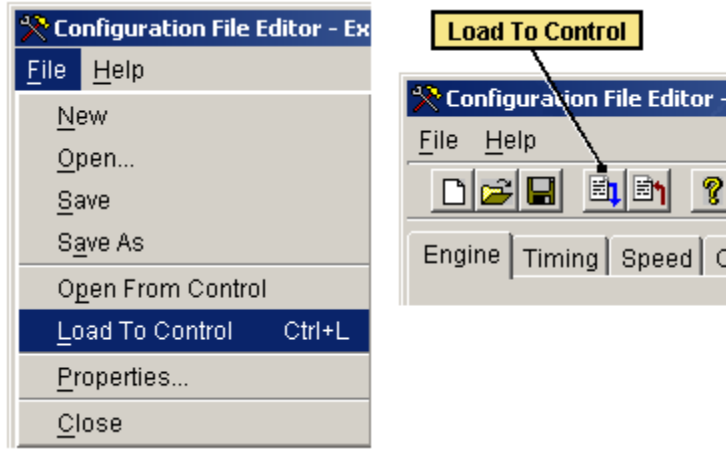

Figure 6-13. Configuration Loading

Load Configuration File to Control

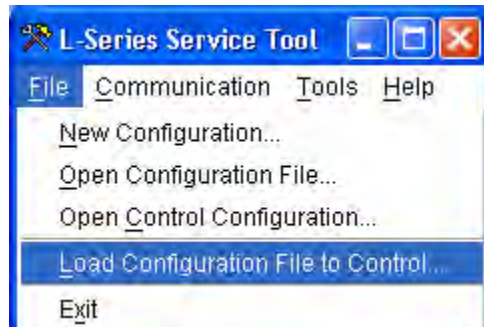

Figure 6-14. Direct Load of Configuration File

The 'Load Configuration File to Control' option under the File menu allows loading a configuration file to a control without opening it. Thus, a password-protected configuration file can be downloaded without entering the password while preserving the configuration's security.

If the control that is being downloaded to already contains a configuration with password protection enabled for configuration loads, that password is still required.

This option is only available in Service Tool version 2.1 and newer.

Configuration Checks

Whenever a configuration is saved or loaded to the control, some basic checks are performed. This check cannot determine if the values are realistic, but it makes sure that values are loaded into the required parameters. If an error is found, the Service Tool will not allow the load or save function to be performed until the error is corrected. Warnings are displayed for the purpose of configuration confirmation, but they will not inhibit the save or load function.

Configuration Errors

1. **Speed Setpoint has not been selected**—A speed setpoint mode must be configured prior to use. See Setpoint tab.
2. **Speed Input has not been configured**—The speed settings must be configured prior to use. See Speed Input section on Overview tab, specifically check the 2 Stroke or 4 Stroke selection.
3. **Improperly configured speed settings (Overspeed setting, Number of Cylinders, or Stroke)**—The speed settings have been configured beyond the sensing limits of the L-Series input capability. This only affects speed inputs configured as ignition. See the Control (for overspeed threshold) and Overview (for speed settings) tabs.
4. **Overspeed threshold must be greater than idle setpoint**—A properly set speed configuration is detected. The Overspeed Threshold must be set to a level higher than the Idle speed setpoint. See the Setpoint and Control tabs.
5. **Overspeed threshold must be greater than rated setpoint**—A properly set speed configuration is detected. The Overspeed Threshold must be set to a level higher than the Rated speed setpoint. See the Setpoint and Control tabs.
6. **Overspeed threshold must be greater than rated 1 setpoint**—A properly set speed configuration is detected. The Overspeed Threshold must be set to a level higher than the Rated1 speed setpoint. See the Setpoint and Control tabs.
7. **Overspeed threshold must be greater than rated 2 setpoint**—A properly set speed configuration is detected. The Overspeed Threshold must be set to a level higher than the Rated2 speed setpoint. See the Setpoint and Control tabs.
8. **Rated setpoint must be greater than the idle setpoint**—A properly set speed configuration is detected. The Rated speed setpoint must be set to a level higher than the Idle speed setpoint. See the Setpoint and Control tabs.
9. **Rated 1 setpoint must be greater than the idle setpoint**—A properly set speed configuration is detected. The Rated1 speed setpoint must be set to a level higher than the Idle speed setpoint. See the Setpoint tab.
10. **Rated 2 setpoint must be greater than the idle setpoint**—A properly set speed configuration is detected. The Rated2 speed setpoint must be set to a level higher than the Idle speed setpoint. See the Setpoint tab.
11. **Password must be set when security is enabled**—To use security, a password must be selected. See Security tab.
12. **Configured Run-Enable discrete in as Always Off**—The Run Enable discrete input cannot be Always Off or the unit will never run. See the Discrete I/O tab.
13. **When dynamics 2 is set to rated-curve mode, dynamics 1 must be in rated-curve or idle-rated-curve mode**—An incompatibility between the Dynamics modes has been detected. To use the Rated curve dynamics option for dynamics 2, the Rated curve or Idle/Rated curve option must be selected for dynamics 1. See the Dynamics tab.

14. **When dynamics 2 is set to idle-rated-curve mode, dynamics 1 must be in idle-rated-curve mode**—An incompatibility between the Dynamics modes has been detected. To use the Idle/Rated curve dynamics option for dynamics 2, the Idle/Rated curve option must also be selected for dynamics 1. See the Dynamics tab.
15. **Configured Dual Dynamics but no Dual-Dynamics discrete in**—An incompatibility between the Dynamics mode and Dual Dynamics discrete input is detected. To use the Idle/Rated dynamics option, the Dual Dynamics discrete input cannot be Always Off. See the Dynamics and Discrete I/O tabs.
16. **Configured Idle/Rated Dynamics but no Idle/Rated discrete in**—An incompatibility between the Dynamics mode and Idle/Rated discrete input is detected. To use the Idle/Rated dynamics option, the Idle/Rated discrete input cannot be Always Off. See the Dynamics and Discrete I/O tabs.
17. **Configured Idle/Rated Dynamics Curve but no Idle/Rated discrete in**—An incompatibility between the Dynamics mode and Idle/Rated discrete input is detected. To use the Idle/Rated curve dynamics option, the Idle/Rated discrete input cannot be Always Off. See the Dynamics and Discrete I/O tabs.
18. **Configured Idle/Rated Speed Setpoint but no Idle/Rated discrete in**—An incompatibility between the Speed setpoint mode and Idle/Rated discrete input is detected. To use the Idle/Rated option, the Idle/Rated discrete input cannot be Always Off. See the Setpoint and Discrete I/O tabs.
19. **Configured Rated1/Rated2 Speed Setpoint but no Rated2 discrete in**—An incompatibility between the Speed setpoint mode and Rated2 discrete input is detected. To use the Rated1/Rated2 option, the Rated2 discrete input cannot be Always Off. See the Setpoint and Discrete I/O tabs.
20. **Configured Idle/Rated1/Rated2 Speed Setpoint but no Idle/Rated discrete in**—An incompatibility between the Speed setpoint mode and Rated2 discrete input is detected. To use the Idle/Rated1/Rated2 option, the Rated2 discrete input cannot be Always Off. See the Setpoint and Discrete I/O tabs.
21. **Configured Idle/Rated1/Rated2 Speed Setpoint but no Rated2 discrete in**—An incompatibility between the Speed setpoint mode and Rated2 discrete input is detected. To use the Idle/Rated1/Rated2 option, the Rated2 discrete input cannot be Always Off. See the Setpoint and Discrete I/O tabs.
22. **Configured Droop Digital Input but no Droop discrete in**—An incompatibility between the Droop mode and Droop discrete input is detected. To use the Droop Discrete input option, the Droop discrete input cannot be Always Off or Always On. See the Modifiers and Discrete I/O tabs.
23. **Configured Raise/Lower Bias but no Raise discrete in**—An incompatibility between the Speed setpoint and Raise Speed discrete input is detected. To use the Speed Setpt Raise/Lower, the Raise discrete input cannot be Always Off or Always On. See the Setpoint and Discrete I/O tabs.
24. **Configured Raise/Lower Bias but no Lower discrete in**—An incompatibility between the Speed setpoint and Lower Speed discrete input is detected. To use the Speed Setpt Raise/Lower, the Lower discrete input cannot be Always Off or Always On. See the Setpoint and Discrete I/O tabs.
25. **Configured Analog or Raise/Lower Bias but no Raise discrete in**—An incompatibility between the Speed setpoint and Raise Speed discrete input is detected. To use the Speed Setpt Analog or Raise/Lower option, the Raise discrete input cannot be Always Off or Always On. See the Setpoint and Discrete I/O tabs.
26. **Configured Analog or Raise/Lower Bias but no Lower discrete in**—An incompatibility between the Speed setpoint and Lower Speed discrete input is detected. To use the Speed Setpt Analog or Raise/Lower option, the Lower discrete input cannot be Always Off or Always On. See the Setpoint and Discrete I/O tabs.

27. **Rated Speed Setpoint mode selected and Idle Rated Dynamics selected**—An incompatibility between the Speed setpoint and Speed Dynamics is detected. See the Setpoint and Dynamics tabs.
28. **Rated Speed Setpoint mode selected and Idle Rated Curve Dynamics selected**—An incompatibility between the Speed setpoint and Speed Dynamics is detected. See the Setpoint and Dynamics tabs.
29. **Startup Select Rated 1/2 mode selected and Idle Rated Dynamics selected**—An incompatibility between the Speed setpoint and Speed Dynamics is detected. See the Setpoint and Dynamics tabs.
30. **Startup Select Rated 1/2 mode selected and Idle Rated Curve Dynamics selected**—An incompatibility between the Speed setpoint and Speed Dynamics is detected. See the Setpoint and Dynamics tabs.
31. **Runtime Select Rated 1/2 Mode selected and Idle Rated Dynamics selected**—An incompatibility between the Speed setpoint and Speed Dynamics is detected. See the Setpoint and Dynamics tabs.
32. **Runtime Select Rated 1/2 Mode selected and Idle Rated Curve Dynamics selected**—An incompatibility between the Speed setpoint and Speed Dynamics is detected. See the Setpoint and Dynamics tabs.

Configuration Warnings

1. **Multiple functions configured for Aux1 input**—This indication is provided to make sure the Aux1 input was configured as expected.
2. **Multiple functions configured for Aux2 input**—This indication is provided to make sure the Aux2 input was configured as expected.
3. **Multiple functions configured for Aux3 input**—This indication is provided to make sure the Aux3 input was configured as expected.
4. **Multiple functions configured for Aux4 input**—This indication is provided to make sure the Aux4 input was configured as expected.

Chapter 7.

Setup and Tuning

Introduction

The L-Series is configured using the Service Tool, refer to Chapter 5 for Service Tool installation and connection instructions. This chapter covers the process of tuning and servicing the control via the L-Series Service Tool. It is assumed that the control has already been installed on the engine.

An application requires the following setup steps. In many applications these steps have already been performed by the OEM.

- Configure the L-Series control (configuration is covered in Chapter 6).
- Tune the Speed control loop PID.

The following optional features are also available:

- Calibrate the Position Feedback range.
- Verify Position feedback calibration.
- Tune the Position control loop PID. For most applications, the default gains do not need to be changed.
- Modify Configuration settings (speed, speed setpoint, fuel limiting).



WARNING

An unsafe condition could occur with improper use of these software tools. Only trained personnel should have access to these tools.

IMPORTANT

Setup and tuning features can be individually password protected for security purposes. If security is applied, these features will not be accessible without the password.

IMPORTANT

Many applications are delivered pre-configured, calibrated, and tuned. For most applications, the default gains do not need to be changed. Min Position and Fail Direction should be checked.

Tuning the Speed PID

The Service Tool can be used to tune the Speed PID or to just trend/monitor the speed PID output. The Speed PID Dynamics screen (Figure 7-1) is opened by selecting 'Edit Speed Dynamics' under the 'Tools' menu.

Pressing the Properties button pops open the Properties Window. From this window the user can adjust the trending window properties including the speed range, update rate and display range.

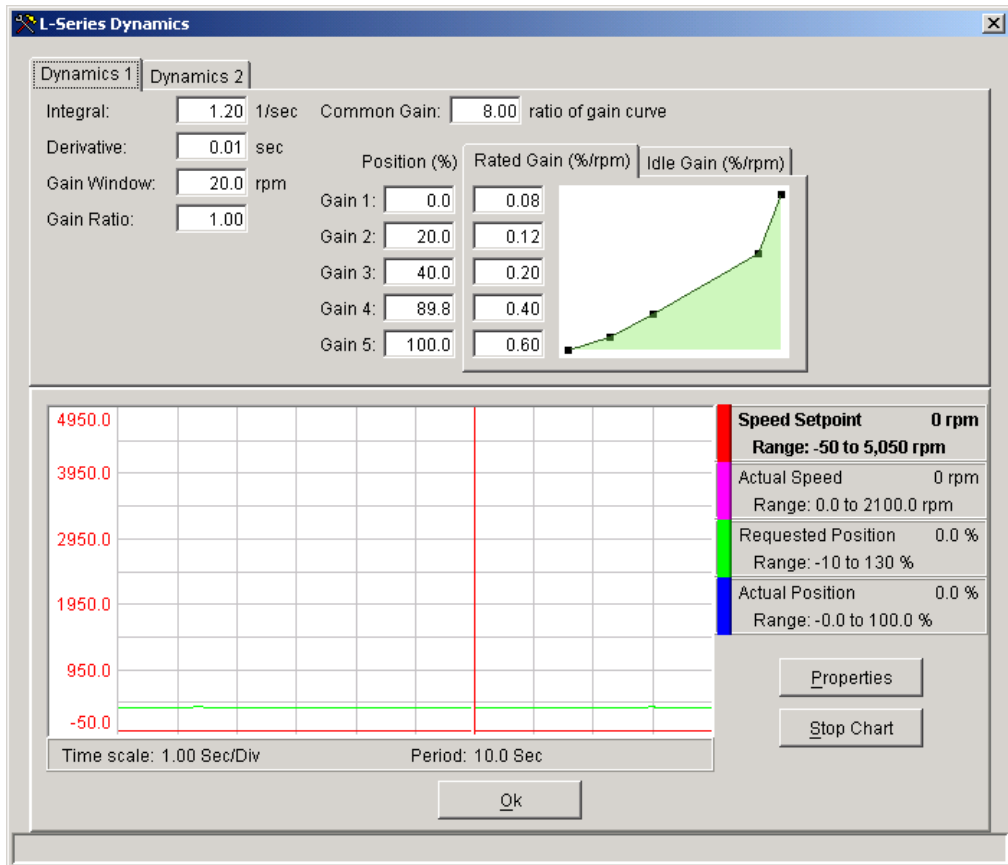

Figure 7-1. Service Tool–Speed Dynamics

Editing of Configuration Settings

If configured, a window (Figure 7-2) is selectable under that Tools menu that allows editing of various configuration settings. The settings in this window are a subset of the complete configuration and are not password protected. When this feature is used, the complete configuration is typically password protected.

The settings in this window can only be changed while connected to the control (on-line) and when the engine is stopped (speed is zero). This option is only available if the 'Allow unsecured tuning of speed input and speed settings' and/or 'Allow unsecured tuning of under-torque fuel limiter settings' are selected on the Security tab in the Configuration Editor. The settings available are dependent on software version and configured options. The Modifiers tab is only available in Service Tool version 2.1 and newer.

For details on the parameters that appear in this window, refer to Chapter 6.

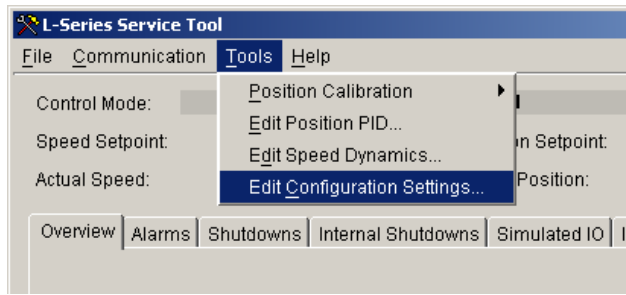

Figure 7-2a. Edit Configuration Settings Menu (5418-2193 software only)

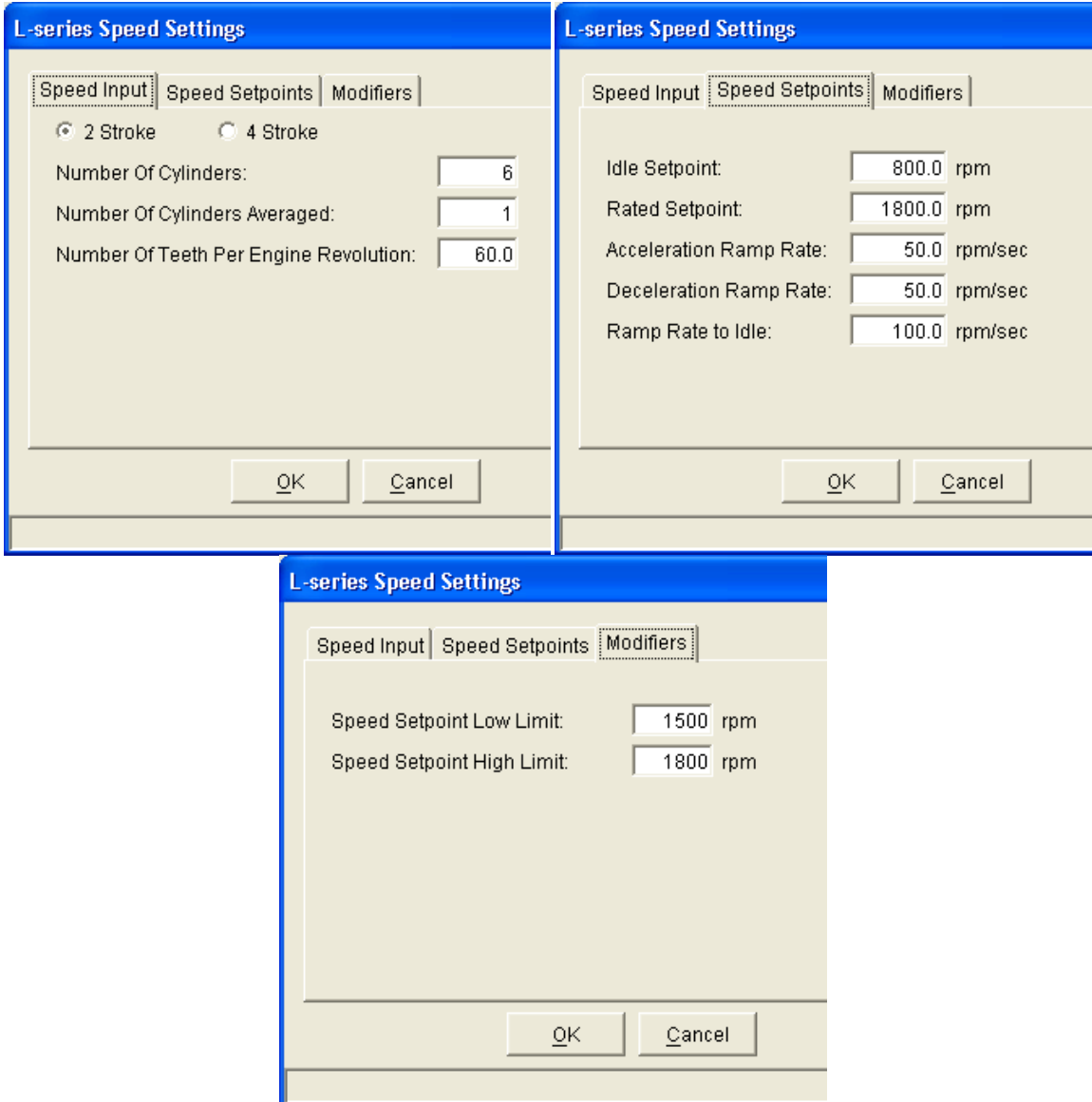

Figure 7-2b. Speed Input Window (5418-1680 and -2226 software versions)

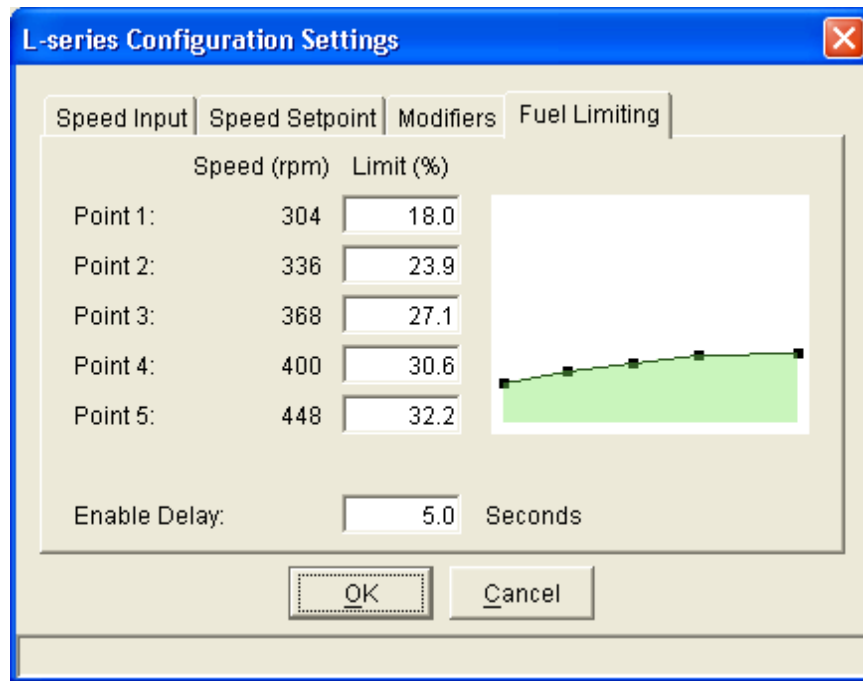

Figure 7-2c. Configuration Settings Window (5418-2193 software only)

IMPORTANT

A Cancel command will prevent the control from saving any changes into permanent non-volatile memory; however, the values are still displayed and used out of RAM. To completely cancel any changes, power to the control must be cycled.

Tuning the Position PID

The Position PID tuning screen (Figure 7-3) is opened by selecting 'Edit Position PID' from the 'Tools' menu. The Service Tool can be used to tune the Position PID or to just trend/monitor the position PID output. In addition, the L-Series control can be put into a manual control mode from this screen by selecting the "Enable Manual Position Tuning" checkbox. Once in manual mode, the position setpoint box is highlighted and the value displayed is actively positioning the output. Use this command to create step changes for the PID and monitor the response using the displayed trend.

Pressing the Properties button pops open the Properties Window (Figure 7-4). From this window the user can adjust the trending window properties including the update rate and display range.

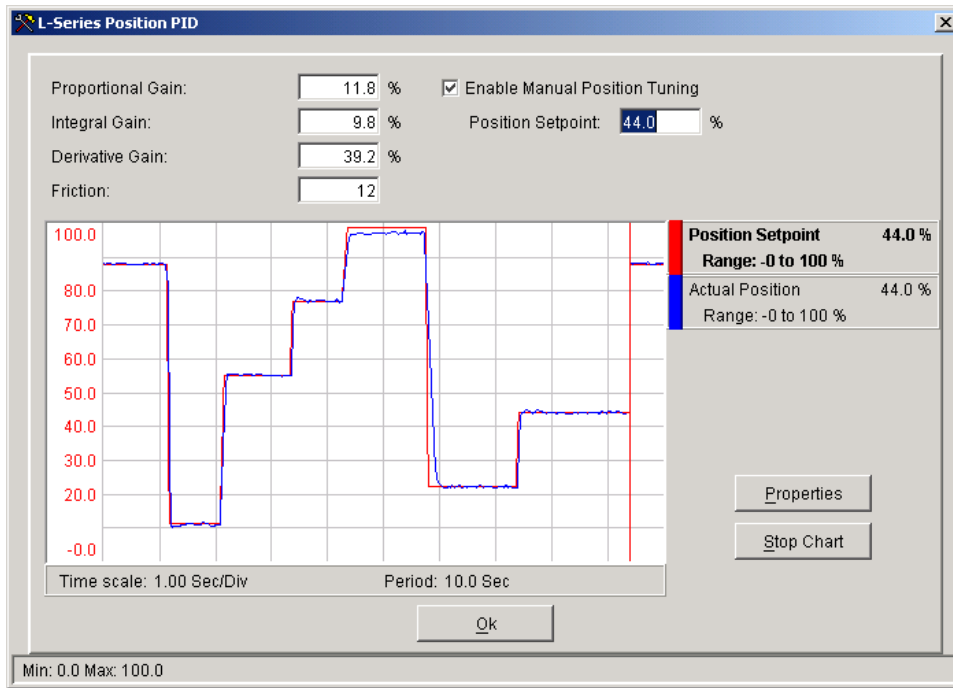

Figure 7-3. Service Tool—PID Tuning Window

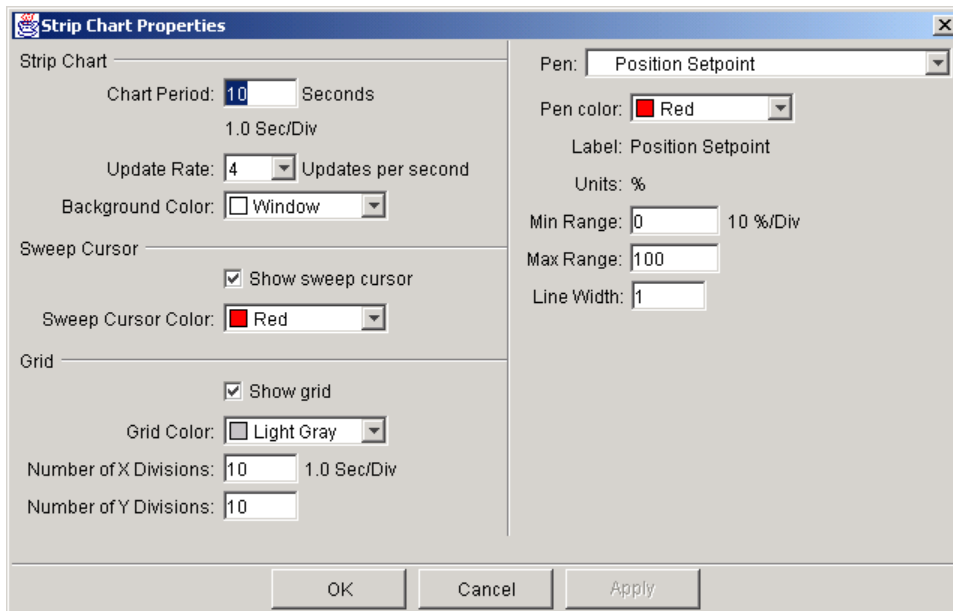

Figure 7-4. Service Tool—PID Tuning Properties Window

Position Calibration and Verification

Position calibration is available to map the position command input to the actual rotational travel of the unit. It is only used when the full travel of the actuator is constrained or limited such that 0 to 60 degrees of travel is not used. For example, an application-specific position calibration could map 0–100% position command to 10–40 degrees actual rotation.

There are two methods available to perform a position calibration: Automatic or Manual. If the application has hard stops that correspond to the actual min/max travel, then either Auto or Manual methods can be used—although auto is easier. If hard stops are not available, then the auto method will give invalid results and the manual method must be followed.

The Service Tool can be used to calibrate the control to end user stops (physical or soft) or to verify the position calibration. To get to the Position Calibration screens select the desired function from Position Calibration under the Tools menu selection.

IMPORTANT Position Calibration is only used when the full travel of the actuator is constrained or limited such that 0 to 60 degrees of travel is not used.

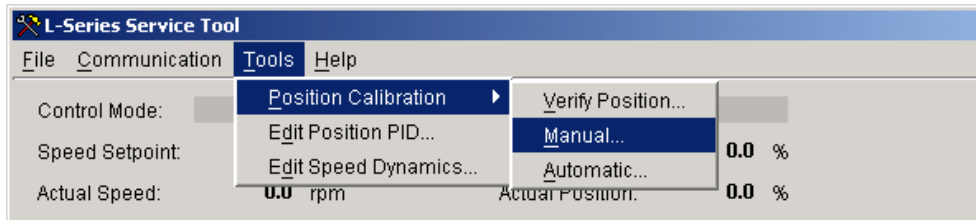

Figure 7-5. Service Tool—Manual Position Calibration selection

Calibration Sequence Overview

The following outlines the basic steps required to execute the position calibration.

Automatic Mode

1. Select Automatic Position Calibration Mode.
2. Select cw or ccw Direction.
3. L-Series automatically rotates in both cw and ccw directions until the stops are detected. The values are then captured and stored.
4. When completed, cycle the power on the L-Series.
5. It is recommended that a Position Verification be performed to confirm the calibration is correct. See Position Verification below.

Manual

1. Determine the rotational travel limits. This can be done by positioning the unit to the minimum and maximum positions and recording the position settings.
2. Select Manual Position Calibration Mode.
3. Select Direction.
4. Enter the pre-determined rotational travel limits values.
5. When completed, cycle the power on the L-Series.
6. It is recommended that a Position Verification be performed to confirm the calibration is correct. See Position Verification below.

Position Verification

The Position Verification screen (Figure 7-6) is opened by selecting 'Verify Position' from the 'Position Calibration' drop-down under the 'Tools' menu. When the Verify Position screen is entered, the control is put into position control and the position is set to the position the control was at when the screen was entered. The screen displays the "User" Requested Position, Actual Position, Minimum Position, and Maximum Position. These User Positions are calculated from the user-calibrated stops.

The Full Travel Actual Position is the full stroke factory position without user stops after software linearization. The Full Travel Sensor Position is the full stroke factory position without user stops before software linearization. The Full Travel Sensor Position will match the TPS Output Signal.

The Verify Position screen can be used to check the calibration or to get the minimum and maximum position values for the manual calibration. If the Enable Requested Position Tuning box is checked the valve can be positioned anywhere from 0 to 100% of the user minimum and maximum stops by entering a value into the Requested Position. If the Enable Requested Position Tuning box is unchecked the valve will go limp and can be physical positioned by hand.

IMPORTANT

If the full factory position calibration range is not being used (the Manual or Automatic Calibration has been performed) and the minimum position direction is changed, the calibration must be run again for the Verify Position mode to work correctly.

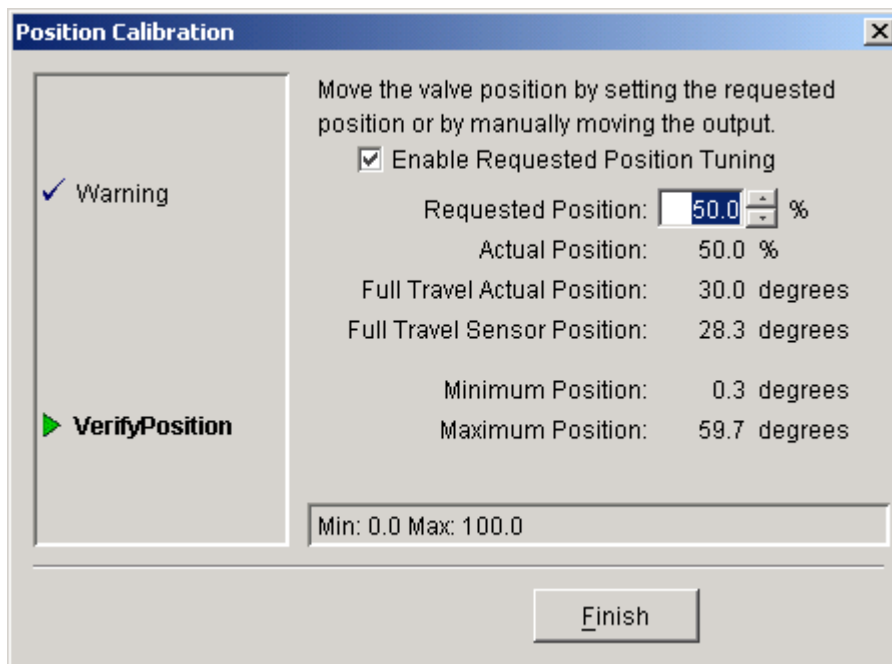

Figure 7-6. Service Tool—Verify Position Calibration

Manual

The Manual position calibration screen (figure 7-7) is opened by selecting 'Manual' from the 'Position Calibration' drop-down under the 'Tools' menu. The manual calibration mode is used to set the minimum position and fail direction and to calibrate the valve to user soft stops (inside of any physical stops). The first screen to appear when entering the manual mode is used to set the minimum position and fail direction. This setting must be correct before manually calibrating the valve.

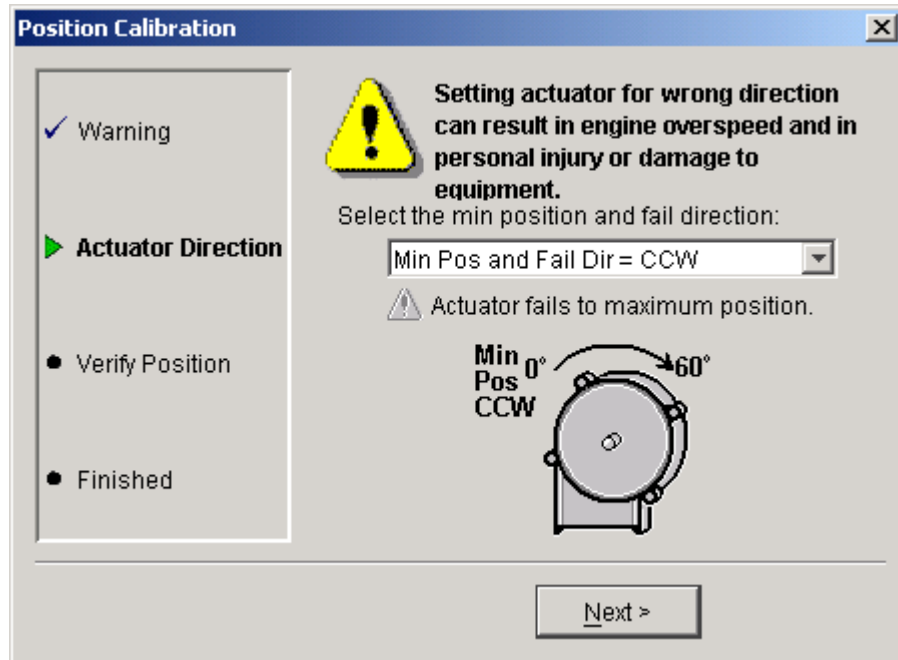

Figure 7-7. Service Tool—Manual Position Calibration

The next screen is used to set the minimum and maximum positions for the user soft stops. To find the minimum and maximum soft stops use the verify position mode described above to position the valve and use the Full Travel Actual Position reading for minimum and maximum position values.

IMPORTANT

After leaving this mode, power must be cycled for the new settings to take effect.

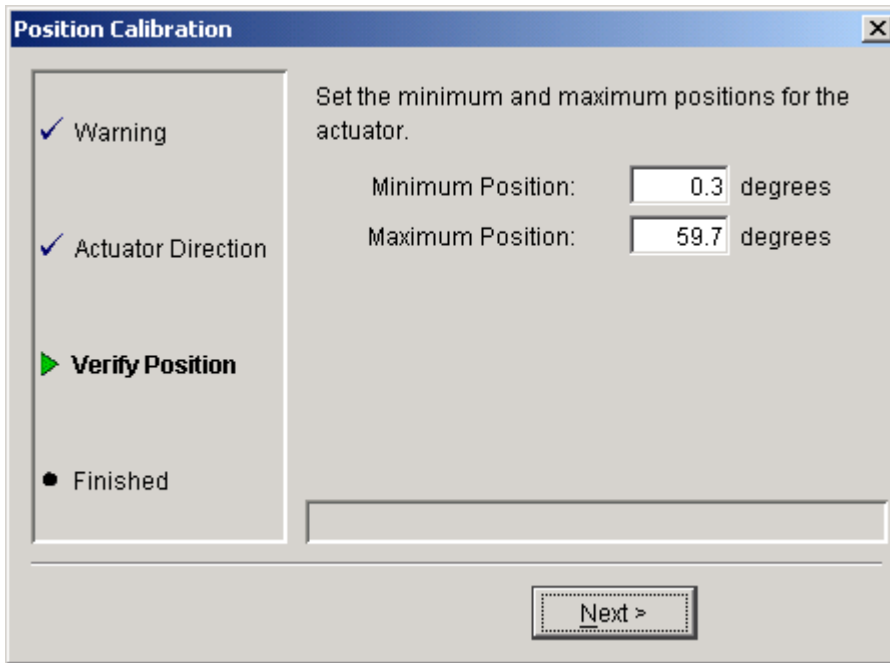

Figure 7-8. Service Tool—Manual Position Calibration Settings

Automatic

The Automatic position calibration screen (Figure 7-9) is opened by selecting 'Automatic' from the 'Position Calibration' drop-down under the 'Tools' menu. The automatic calibration mode is used to set the minimum position and fail direction and to calibrate the valve to user physical stops (mechanical hard stops). Like the manual mode, the first screen to appear is used to set the minimum position and fail direction. This setting must be correct before automatic calibration is performed.

After setting minimum position and fail direction the screen below will appear. The control is now moving first to the ccw stop and then to the cw stop to get the physical minimum and maximum positions.

IMPORTANT

After leaving this mode, power must be cycled for the new settings to take effect.

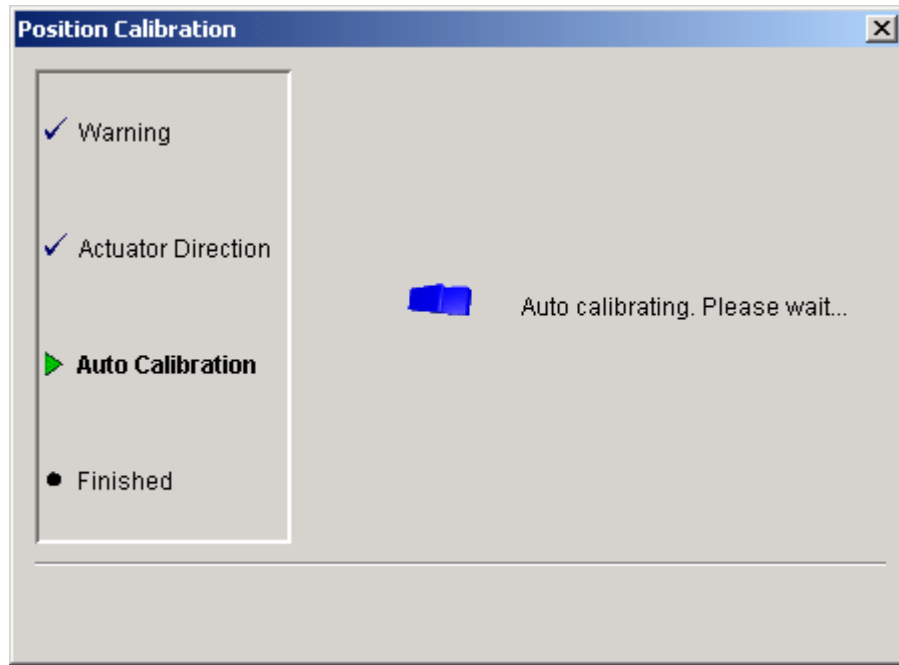

Figure 7-9. Service Tool—Auto Position Calibration

Chapter 8.

Troubleshooting

Introduction

This chapter presents several broad categories of application failures typically experienced in the field, possible causes, and some tests used to verify the causes. Because the exact failure experienced in the field is the product of the mechanical/electrical failure combined with the configuration file resident in the control, it is left as the OEM's responsibility to create a more detailed troubleshooting chart for the end user. Ideally, this end-user troubleshooting chart will contain information about mechanical, electrical, engine, and load failures in addition to the possible governor failures. For more detailed information about governor system failure modes and effects, contact Woodward for a copy of the system DFMEA.

The troubleshooting scenarios listed below assume that the end user has a digital multimeter at his disposal for testing voltages and checking continuity, and assume that the application has been engineered and tested thoroughly.

There are four parts to the troubleshooting section:

- General Troubleshooting
- Engine/Generator Troubleshooting
- Troubleshooting Alarm/Shutdown Diagnostic Flags
- Input/Output (I/O) Troubleshooting

WARNING

The engine, turbine, or other type of prime mover should be equipped with an overspeed shutdown device to protect against runaway or damage to the prime mover with possible personal injury, loss of life, or property damage.

The overspeed shutdown device must be totally independent of the prime mover control system. An overtemperature or overpressure shutdown device may also be needed for safety, as appropriate.

WARNING

The actions described in this troubleshooting section are not always appropriate in every situation. Always make sure that any action taken will not result in loss of equipment, personal injury, or loss of life.

WARNING

The L-Series wiring must be in accordance with North American Class I, Division 2 or Zone 2 wiring methods as applicable, and in accordance with the authority having jurisdiction.

CAUTION

The L-Series is used on prime movers that typically have a high noise level. Always use appropriate hearing protection while working around the L-Series.

General System Troubleshooting Guide

The following is a general troubleshooting guide for areas to check which may present potential difficulties. By making these checks appropriate to your engine/turbine before contacting Woodward for technical assistance, your system problems can be more quickly and accurately assessed.

- Is the wiring correct?
- Is the direction of the stroke correct?
- Is the direction of the failsafe shutdown correct?
- Does the valve move through its proper stroke smoothly?
- Does the valve travel its full stroke?
- Can mid-stroke be obtained and held?
- Does the valve fully seat (close)?
- Does the valve fully open?

Engine/Generator Troubleshooting

Problem	Possible Cause	Suggested Test/Correction
Engine does not start	Stuck throttle/frozen shaft	Move throttle by hand. Assess smoothness, friction, and return spring force.
	Power not applied to control	Disconnect starter motor solenoid. Disconnect harness from governor. Test for +12/24 V between +12/24 V pin and ground pin.
	Run Enable not closed	Verify status of input. Measure input. Verify input and configuration using Service Tool.
	Incorrect configuration in control.	Using Service Tool, read configuration from control and evaluate parameters for correction.
	Fault detected in control.	Using Service Tool, read faults from control. Verify/correct any shutdown conditions.
	MPU gap too large	Remove and reinstall MPU per OEM's instructions. Rotate engine manually to check for interference.
	MPU signal connection open	Disconnect harness from governor. Test for at least 1 Vrms between MPU+ pin and MPU- pin while the flywheel is spinning.
Ignition signal connection open	Disconnect harness from governor. Test for bouncing voltage between IGN pin and ground pin while the engine is starting/firing.	

Problem	Possible Cause	Suggested Test/Correction
The actuator is not opening the fuel control valve during engine cranking.	<p>The control is configured for the wrong opening direction.</p> <p>The Run Enable input is not enabled. See overview screen on service tool.</p> <p>The control has detected a shutdown situation and has not been reset.</p> <p>There is no power supplied to the control.</p> <p>The control does not read any speed. Speed sensor defect, wiring defect, or incorrect speed sensor installation.</p> <p>The control reads an actual engine speed below the start speed threshold.</p> <p>The Start fuel 1 and or 2 setup is incorrectly set.</p>	<p>Check cw/ccw min fuel direction configuration.</p> <p>Make sure the run enable input is made active. Check wiring.</p> <p>Reset the control by cycling power to the control, hitting reset on the Service Tool, or toggling the run enable switch.</p> <p>Check fuse, wiring, and battery voltage.</p> <p>Fix or replace speed sensor, fix wiring or install speed sensor correctly according to the speed sensor manual.</p> <p>Start speed is set too high. Lower start speed threshold.</p> <p>Set up the Start Fuel to the correct value for this engine.</p>
The engine overspeeds on start-up.	<p>An overshoot in speed is caused by an excessive speed setpoint acceleration.</p> <p>The overspeed trip level is configured incorrectly.</p> <p>Incorrect speed input configuration.</p> <p>Gains not set properly for transients</p> <p>Start Fuel Limit not set properly</p> <p>Speed sensing error</p>	<p>Acceleration ramp rate is set too high.</p> <p>Verify the overspeed trip setting configuration.</p> <p>Verify the input speed configuration settings (number of teeth). Check the sensed speed compared to an external engine speed indicator.</p> <p>If overspeed occurs on transient, raise common gain to reduce overshoot.</p> <p>Lower rpm run threshold or lower start fuel position.</p> <p>Follow instructions for MPU or ignition signal intermittent under Speed Sensor Error.</p>
Engine starts, but shuts down on error	<p>Speed sensing error</p> <p>Error detected by control.</p>	<p>Follow instructions for MPU or ignition signal intermittent under Speed Sensor Error.</p> <p>Verify the exact cause of the error using the Service Tool.</p>
Incorrect mode of operation (speed, speed bias function, dynamics)	AUX inputs shorted or open	Disconnect starter motor solenoid. Disconnect harness from governor. Check for correct voltage level between AUX pin(s) under question and ground pin for known application modes.

Problem	Possible Cause	Suggested Test/Correction
The engine will not go to rated speed.	<p>The Idle Rated input wiring is defective. See overview screen for input position.</p> <p>The high, low, and active open or closed selection for the Idle Rated input is selected incorrectly.</p> <p>The Control is not configured for Idle Rated operation.</p>	<p>Check wiring.</p> <p>Set up the correct input modes.</p> <p>Configure the Control for Idle Rated operation if that is the desired operation mode.</p>
The engine will not go to idle speed.	<p>The Idle Rated input wiring is defective. See overview screen for input position.</p> <p>The high, low, and active open or closed selection for the Idle Rated input is selected incorrectly.</p> <p>The Control is not configured for Idle Rated operation.</p>	<p>Check wiring.</p> <p>Set up the correct input modes.</p> <p>Configure the Control for Idle Rated operation if that is the correct operation mode.</p>
The engine will not raise the speed setpoint.	<p>The Raise input wiring is defective. See overview screen for input position.</p> <p>The high, low, and active open or closed selection for the Raise input is selected incorrectly.</p> <p>The Control is not configured for Raise Lower operation.</p> <p>The Lower input is also active and the Analog Raise Lower is configured.</p> <p>The lower is active and only Raise Lower is selected. The Control will lower the speed if Raise and Lower are selected at the same time.</p>	<p>Check wiring.</p> <p>Set up the correct input modes.</p> <p>Configure the Control for Raise Lower operation or Raise Lower and Analog if that is the correct operation mode.</p> <p>Set up the lower input to the correct state. The engine will not lower the speed setpoint.</p> <p>Set up the lower input to the correct state. The engine will not lower the speed setpoint.</p>
The engine will not lower the speed setpoint.	<p>The Lower input wiring is defective. See overview screen for input position.</p> <p>The high, low, and active open or closed selection for the Raise input is selected incorrectly.</p> <p>The Control is not configured for Raise lower operation.</p> <p>The Raise input is also active and the analog Raise Lower is configured. The control is in analog mode.</p>	<p>Check wiring.</p> <p>Set up the correct input modes.</p> <p>Configure the Control for Raise Lower operation or raise lower and analog if that is the desired operational mode.</p> <p>Set the lower input to the correct state. The engine will not lower the speed setpoint.</p>

Problem	Possible Cause	Suggested Test/Correction
Engine unstable	Improperly tuned speed or position PID dynamics.	Using Service Tool, tune the position dynamics. In most cases the default dynamics are appropriate. Using Service Tool, tune the speed dynamics.
	Intermittent or incorrect speed signal.	Verify speed signal shielding recommendations (chapter 3) have been followed. Verify speed input is wired correctly. Ignition and MPU cannot be wired simultaneously.
	Dual dynamics discrete input shorted or open	Disconnect starter motor solenoid. Activate application. Check for correct voltage level between dual dynamics AUX pin and ground pin for known application mode.
Poor frequency control	Improperly tuned dynamics.	Using Service Tool, tune the speed control dynamics.
	Improperly tuned dynamics.	Using Service Tool, tune the position dynamics. In most cases the default dynamics are appropriate.
	Friction improperly set.	Using Service Tool, adjust the Friction setting.
Unable to develop full power	Non-indexed linkage slipped on shaft.	Manually verify full travel of throttle plate.
	Fault detected in control.	Using Service Tool, view status of fault codes. Take appropriate action for active faults.
	Shorted/bad MAP sensor signal	If using MAP fuel limiting, disconnect starter motor solenoid. Verify the input voltage matches expected voltage for known atmospheric conditions.
Discrete output not working	Wiring fault.	Check the wiring leading to pin 9 for open connections or misconnections. Verify that pin 9 is not connected directly to input power or ground.
	Configuration.	Using the Service Tool, verify that the faults and shutdowns are selected properly and that the output is configured for expected operation (either normally "on" or normally "off").
Service Tool not communicating—'Not Connected' status indicated	Wiring fault.	Check AUX3 and AUX4 for loose or misconnected connections.
	The Service tool is disconnected.	Verify harness setup and connections (see Chapter 4).
	The wrong communication port has been selected.	Check that Service Tool is running. Verify the port setting is correct. Check fuse, wiring, and battery voltage. Connect the service tool by using the connect menu.

Problem	Possible Cause	Suggested Test/Correction
Service Tool not communicating—Error message displayed on PC when trying to connect	Old version of Service Tool or file corruption or bad install.	Re-install Service Tool, get the latest version from the Woodward web site (www.woodward.com/software)
Service Tool will not accept password	Cap Lock is on.	Password is case sensitive, make sure you enter the password correctly using upper and lower case. If password is lost contact the OEM for retrieval.

Troubleshooting Diagnostic Fault Flags

Error Flag	Description	Possible Source	Possible Action
Supply Voltage Failure	<p>The power supply voltage is higher than the diagnostic limits.</p> <p>The Power supply voltage is lower than the diagnostic limits.</p>	<p>Bad or damaged battery.</p> <p>Defective battery charging system.</p> <p>Incorrect setting of power supply voltage level.</p> <p>Power supply wiring too long or too thin. Control will flag low voltage during higher power uses.</p>	<p>Replace battery.</p> <p>Fix battery charging system.</p> <p>Set correct voltage levels on power supply.</p> <p>Make sure wiring is of the correct thickness and length according to manual.</p>
Temperature Sense Failed	This error is set if the temperature inside the control is higher or lower than allowed by the specifications.	<p>Control has been placed in an environment that is too hot or too cold.</p> <p>The internal temperature sensor is defective. This can be determined by checking the temperature of the unit and comparing this to the service tool value of the electronics temperature.</p>	<p>Lower temperature by adding cooling, heat shielding, moving the unit, etc.</p> <p>Increase temperature by adding heat.</p> <p>Return unit to Woodward for repair.</p>
Governor High Speed	This error is set if the actual speed is higher than the speed setpoint plus a configured limit for longer than the configured time.	<p>The actuator is not capable of closing the fuel control valve (max torque).</p> <p>The fuel control valve is jammed or stuck.</p> <p>The actuator is setup incorrectly. Zero percent position will not completely close the fuel valve.</p> <p>The linkage is moved or disconnected.</p> <p>The engine is not responding correctly.</p> <p>The detection margins are set too low.</p> <p>The detection time is set up too short. A normal load transient will trigger this error.</p>	<p>Check the torque needed to close the fuel valve against the available torque.</p> <p>Fix or replace valve.</p> <p>Run the position setup wizard to set up the actuator correctly. 0% will close fuel valve.</p> <p>Fix or replace linkage.</p> <p>Check with the engine troubleshooting manual.</p> <p>Set the margins to an acceptable level.</p> <p>Set the detection time to an acceptable level.</p>

Error Flag	Description	Possible Source	Possible Action
Governor Low Speed	This error is set if the actual speed is lower than the speed setpoint minus a configured limit for longer than the configured time.	<p>The actuator is not capable of opening the fuel control valve (max torque).</p> <p>The fuel control valve is jammed or stuck.</p> <p>The actuator is set up incorrectly. 100% position will not completely open the fuel valve.</p> <p>The linkage is moved or disconnected.</p> <p>The engine is not responding correctly.</p> <p>The fuel supply to the engine is restricted.</p> <p>The load on the engine is too high.</p> <p>The detection margins are set too low.</p> <p>The detection time is set up too short. A normal load transient will trigger this error.</p>	<p>Check the torque needed to open the fuel valve against the available torque.</p> <p>Fix or replace valve.</p> <p>Run the position setup wizard to set up the actuator correctly. 100% will open fuel valve.</p> <p>Fix or replace linkage.</p> <p>Review the engine troubleshooting manual.</p> <p>Open restriction in fuel supply, check filters.</p> <p>Reduce load on the engine to an acceptable limit for this engine.</p> <p>Set the margins to an acceptable level.</p> <p>Set the detection time to an acceptable level.</p>
Max Starting Time	The max starting time error will be set if the engine is not above run speed within a configured amount of time.	<p>Start fuel is set to low. Engine will not reach run speed.</p> <p>Low temperature of engine will not start engine at start fuel selected.</p> <p>Engine is defective and will not start.</p>	<p>Set start fuel limit to a level where the engine will reach run speed or lower run speed if a possible.</p> <p>Select two start fuels with ramp to ramp to more or less fuel during the engine start.</p> <p>Check with the engine troubleshooting manual.</p>
Overspeed	This diagnostic flag will be set if the actual engine speed is higher than the overspeed threshold.	<p>The overspeed parameter has not been set. Factory default is zero rpm.</p> <p>Engine dynamics are set up too slow for a sudden load reject.</p> <p>The actuator is not capable of closing the fuel control valve (max torque).</p> <p>The fuel control valve is jammed or stuck.</p> <p>The actuator is set up incorrectly. Zero percent position will not completely close the fuel valve.</p> <p>The linkage is moved or disconnected.</p> <p>The engine is not responding correctly.</p>	<p>Set the correct overspeed value.</p> <p>Increase the gains, decrease gain window, or increase gain ratio.</p> <p>Check the torque needed to close the fuel valve against the available torque.</p> <p>Fix or replace valve.</p> <p>Run the position setup wizard to set up the actuator correctly. 0% will close fuel valve.</p> <p>Fix or replace linkage.</p> <p>Check with the engine troubleshooting manual.</p>

Error Flag	Description	Possible Source	Possible Action
Speed Sensor Failed	This diagnostic flag will be set if the speed input pulses have not been detected.	<p>Damaged, loss of speed or wiring.</p> <p>Damaged connector.</p> <p>Incorrect installation of speed sensor.</p> <p>Incorrect configuration of speed sensor.</p> <p>Missing pulses on speed gear.</p> <p>MPU gap too large</p> <p>MPU signal connection open</p> <p>Ignition signal connection open</p>	<p>Fix wiring or replace.</p> <p>Verify speed signal shielding recommendations (chapter 3) have been followed.</p> <p>Verify speed input is wired correctly. Ignition and MPU cannot be wired simultaneously.</p> <p>Fix connector or replace.</p> <p>Correct the speed sensor installation. See speed sensor installation manual.</p> <p>Verify configuration settings.</p> <p>Make sure speed gear wheel is not missing any teeth.</p> <p>Remove and reinstall MPU per OEM's instructions. Rotate engine manually to check for interference.</p> <p>Disconnect harness from governor. Test for at least 1 Vrms between MPU+ pin and MPU- pin while the flywheel is spinning.</p> <p>Disconnect harness from governor. Test for bouncing voltage between IGN pin and ground pin while the engine is starting/firing.</p>
Position Error	Indicates demanded position and the actual position are outside the configured limits.	<p>Incorrect position control dynamics or friction setting.</p> <p>Binding or excessive friction in the actuator linkage, or stops are set inside the desired range of travel.</p>	<p>Check/tune position dynamics using the Service Tool.</p> <p>Perform a position calibration.</p> <p>Check all mechanical linkages and stops.</p> <p>Verify Configuration errors settings.</p>
Position Sensor Failure	If the internal position sensor is outside the diagnostic limits.	Internal failure of position sensor.	Return unit to Woodward.
Internal Shutdown	All internal shutdowns will set this flag.	The Control is defective.	Return unit to Woodward.
EEPROM Failure	<p>The software can't write to the EEPROM.</p> <p>The software can't read from the EEPROM.</p>	The Control is defective.	Return unit to Woodward.

Error Flag	Description	Possible Source	Possible Action
Brown Out Reset	The brown-out detection flag indicates that power to the control has sagged to a point of non-operation and is now restored.	<p>Power source voltage drop.</p> <p>Loss of power or intermittent power supply wiring.</p> <p>Power supply wiring too long or too thin. L-Series will reset during transient power uses.</p>	<p>Possible power problem.</p> <p>Check wiring for bad or lost connection.</p> <p>Make sure wiring is of the correct thickness and length according to manual.</p>
Watchdog Reset	The watchdog has reset the Control.	<p>After software update, the software watchdog will reset the Control.</p> <p>The software is disrupted by EMI or an internal component failure.</p>	<p>This is a normal situation. Reset the error code and reset the stored errors.</p> <p>This is an abnormal situation. Return the unit to Woodward.</p>
Overtemperature	High internal temperature.	Detection of high of temperature.	<p>Check ambient temperature around Control.</p> <p>Verify temperature reading using service tool.</p> <p>If the temperatures seem normal, could indicate a problem with the temperature sensor.</p>
Relay Fail Short	Control detected a fault in the discrete out wiring.	Incorrect or intermittent wiring problem.	Check wiring for bad or lost connection.
Run Enable Shutdown	Control detected that the Run Enable discrete in is not active.	<p>Incorrect or intermittent wiring problem.</p> <p>Incorrect configuration.</p>	<p>Check wiring for bad or lost connection.</p> <p>Verify configuration. Check Run Enable setting, verify proper Active Open or Active Closed setting.</p>
Min Fuel Limiting	Indicates that the Min Fuel Limit is active.	<p>Incorrect configuration.</p> <p>Normal operation.</p> <p>Position to speed calibration incorrect.</p>	<p>Verify configuration of fuel limit.</p> <p>This could also be a normal indication during certain modes of operation. Check with engine manufacturer.</p> <p>Check and/or perform a position calibration.</p>

Electrical Troubleshooting Guide

MPU Speed Input

If the speed input is not functioning properly, verify the following:

- Measure the input voltage and frequency.
- Check the values seen by the L-Series driver using the Service Tool and verify that it matches the input signal.
- Check the wiring. Look for loose connections and disconnected / misconnected cables/connections.
- Check the software configuration to ensure that the input is configured properly.

Ignition Speed Input

If the speed input is not functioning properly, verify the following:

- Measure the input voltage and frequency.
- Check the values seen by the L-Series driver using the Service Tool and verify that it matches the input signal.
- Check the wiring. Look for loose connections and disconnected / misconnected cables/connections.
- Check the software configuration to ensure that the input is configured properly.

Analog Input

If an Analog Input is not functioning properly, verify the following:

- Measure the input voltage.
- Verify the input is properly configured.
- Check the values seen by the L-Series driver using the Service Tool and verify that it matches the input signal.
- Verify that there are no or minimal ac components to the Analog Input signal. AC components can be caused by improper shielding.
- Check the wiring. If the inputs are reading 0 or the engineering units correspond to 0 V, look for loose connections and disconnected / misconnected cables/connections.
- Check the software configuration to ensure that the input is configured properly as the Demand Source.

Discrete Input

If a discrete input is not functioning properly, verify the following:

- Measure the input voltage on the terminal block. It should be in the range of 10–28 Vdc.
- Check the status of the input from the Overview screen of the Service Tool.
- Check the wiring, looking for loose connections or misconnected cables.
- Verify the input is properly configured.

Alarm or Shutdown Conditions

If the L-Series control has any alarm or shutdown conditions, refer to Chapter 4 for details on the exact cause of the condition. The Service Tool must be used to determine the cause of any shutdown or alarm condition.

Discrete Output

If the discrete output is not functioning properly, verify the following:

- Measure the output voltage on the terminal block. It should be in the range of 10–28 Vdc when the output is off/false. The voltage will be in this range only if all shutdowns are false, assuming it is configured as Off for Fault. This can be verified through the Service Tool.
- Check the wiring, looking for loose connections or disconnected / misconnected cables.
- Verify the configuration of the output.

Service Tool

If the service tool is not functioning properly, review the installation information in Chapter 5. Verify the following:

- Check the wiring, looking for loose connections or disconnected / misconnected cables.
- Check that Service Tool is running. Verify the Port setting is correct.
- Follow on-screen error messages. Re-install software as needed. The latest version of software is available for download from the Woodward web site (www.woodward.com/software).

Chapter 9. Service Options

Product Service Options

IMPORTANT

There are no serviceable parts on the L-Series.

If you are experiencing problems with the installation, or unsatisfactory performance of a Woodward product, the following options are available:

- Consult the troubleshooting guide in the manual.
- Contact the manufacturer or packager of your system.
- Contact the Woodward Full Service Distributor serving your area.
- Contact Woodward technical assistance (see “How to Contact Woodward” later in this chapter) and discuss your problem. In many cases, your problem can be resolved over the phone. If not, you can select which course of action to pursue based on the available services listed in this chapter.

OEM and Packager Support: Many Woodward controls and control devices are installed into the equipment system and programmed by an Original Equipment Manufacturer (OEM) or Equipment Packager at their factory. In some cases, the programming is password-protected by the OEM or packager, and they are the best source for product service and support. Warranty service for Woodward products shipped with an equipment system should also be handled through the OEM or Packager. Please review your equipment system documentation for details.

Woodward Business Partner Support: Woodward works with and supports a global network of independent business partners whose mission is to serve the users of Woodward controls, as described here:

- A **Full Service Distributor** has the primary responsibility for sales, service, system integration solutions, technical desk support, and aftermarket marketing of standard Woodward products within a specific geographic area and market segment.
- An **Authorized Independent Service Facility (AISF)** provides authorized service that includes repairs, repair parts, and warranty service on Woodward's behalf. Service (not new unit sales) is an AISF's primary mission.
- A **Recognized Engine Retrofitter (RER)** is an independent company that does retrofits and upgrades on reciprocating gas engines and dual-fuel conversions, and can provide the full line of Woodward systems and components for the retrofits and overhauls, emission compliance upgrades, long term service contracts, emergency repairs, etc.
- A **Recognized Turbine Retrofitter (RTR)** is an independent company that does both steam and gas turbine control retrofits and upgrades globally, and can provide the full line of Woodward systems and components for the retrofits and overhauls, long term service contracts, emergency repairs, etc.

A current list of Woodward Business Partners is available at www.woodward.com/support.

Woodward Factory Servicing Options

The following factory options for servicing Woodward products are available through your local Full-Service Distributor or the OEM or Packager of the equipment system, based on the standard Woodward Product and Service Warranty (5-01-1205) that is in effect at the time the product is originally shipped from Woodward or a service is performed:

- Replacement/Exchange (24-hour service)
- Flat Rate Repair
- Flat Rate Remanufacture

Replacement/Exchange: Replacement/Exchange is a premium program designed for the user who is in need of immediate service. It allows you to request and receive a like-new replacement unit in minimum time (usually within 24 hours of the request), providing a suitable unit is available at the time of the request, thereby minimizing costly downtime. This is a flat-rate program and includes the full standard Woodward product warranty (Woodward Product and Service Warranty 5-01-1205).

This option allows you to call your Full-Service Distributor in the event of an unexpected outage, or in advance of a scheduled outage, to request a replacement control unit. If the unit is available at the time of the call, it can usually be shipped out within 24 hours. You replace your field control unit with the like-new replacement and return the field unit to the Full-Service Distributor.

Charges for the Replacement/Exchange service are based on a flat rate plus shipping expenses. You are invoiced the flat rate replacement/exchange charge plus a core charge at the time the replacement unit is shipped. If the core (field unit) is returned within 60 days, a credit for the core charge will be issued.

Flat Rate Repair: Flat Rate Repair is available for the majority of standard products in the field. This program offers you repair service for your products with the advantage of knowing in advance what the cost will be. All repair work carries the standard Woodward service warranty (Woodward Product and Service Warranty 5-01-1205) on replaced parts and labor.

Flat Rate Remanufacture: Flat Rate Remanufacture is very similar to the Flat Rate Repair option with the exception that the unit will be returned to you in “like-new” condition and carry with it the full standard Woodward product warranty (Woodward Product and Service Warranty 5-01-1205). This option is applicable to mechanical products only.

Returning Equipment for Repair

If a control (or any part of an electronic control) is to be returned for repair, please contact your Full-Service Distributor in advance to obtain Return Authorization and shipping instructions.

When shipping the item(s), attach a tag with the following information:

- return number;
- name and location where the control is installed;
- name and phone number of contact person;
- complete Woodward part number(s) and serial number(s);
- description of the problem;
- instructions describing the desired type of repair.

Packing a Control

Use the following materials when returning a complete control:

- protective caps on any connectors;
- antistatic protective bags on all electronic modules;
- packing materials that will not damage the surface of the unit;
- at least 100 mm (4 inches) of tightly packed, industry-approved packing material;
- a packing carton with double walls;
- a strong tape around the outside of the carton for increased strength.

NOTICE

To prevent damage to electronic components caused by improper handling, read and observe the precautions in Woodward manual 82715, *Guide for Handling and Protection of Electronic Controls, Printed Circuit Boards, and Modules*.

Replacement Parts

When ordering replacement parts for controls, include the following information:

- the part number(s) (XXXX-XXXX) that is on the enclosure nameplate;
- the unit serial number, which is also on the nameplate.

Engineering Services

Woodward offers various Engineering Services for our products. For these services, you can contact us by telephone, by email, or through the Woodward website.

- Technical Support
- Product Training
- Field Service

Technical Support is available from your equipment system supplier, your local Full-Service Distributor, or from many of Woodward's worldwide locations, depending upon the product and application. This service can assist you with technical questions or problem solving during the normal business hours of the Woodward location you contact. Emergency assistance is also available during non-business hours by phoning Woodward and stating the urgency of your problem.

Product Training is available as standard classes at many of our worldwide locations. We also offer customized classes, which can be tailored to your needs and can be held at one of our locations or at your site. This training, conducted by experienced personnel, will assure that you will be able to maintain system reliability and availability.

Field Service engineering on-site support is available, depending on the product and location, from many of our worldwide locations or from one of our Full-Service Distributors. The field engineers are experienced both on Woodward products as well as on much of the non-Woodward equipment with which our products interface.

For information on these services, please contact us via telephone, email us, or use our website and reference www.woodward.com/support, and then **Customer Support**.

How to Contact Woodward

For assistance, call one of the following Woodward facilities to obtain the address and phone number of the facility nearest your location where you will be able to get information and service.

Electrical Power Systems

Facility	Phone Number
Australia	+61 (2) 9758 2322
Brazil	+55 (19) 3708 4800
China	+86 (512) 6762 6727
Germany:	
Kempen	+49 (0) 21 52 14 51
Stuttgart	+49 (711) 78954-0
India	+91 (129) 4097100
Japan	+81 (43) 213-2191
Korea	+82 (51) 636-7080
Poland	+48 12 618 92 00
United States	+1 (970) 482-5811

Engine Systems

Facility	Phone Number
Australia	+61 (2) 9758 2322
Brazil	+55 (19) 3708 4800
China	+86 (512) 6762 6727
Germany:	
Stuttgart	+49 (711) 78954-0
India	+91 (129) 4097100
Japan	+81 (43) 213-2191
Korea	+82 (51) 636-7080
The Netherlands	+31 (23) 5661111
United States	+1 (970) 482-5811

Turbine Systems

Facility	Phone Number
Australia	+61 (2) 9758 2322
Brazil	+55 (19) 3708 4800
China	+86 (512) 6762 6727
India	+91 (129) 4097100
Japan	+81 (43) 213-2191
Korea	+82 (51) 636-7080
The Netherlands	+31 (23) 5661111
United States	+1 (970) 482-5811

You can also contact the Woodward Customer Service Department or consult our worldwide directory on Woodward's website (www.woodward.com/support) for the name of your nearest Woodward distributor or service facility.

For the most current product support and contact information, please refer to the latest version of publication **51337** at www.woodward.com/publications.

Technical Assistance

If you need to telephone for technical assistance, you will need to provide the following information. Please write it down here before phoning:

General

Your Name _____
Site Location _____
Phone Number _____
Fax Number _____

Prime Mover Information

Engine/Turbine Model Number _____
Manufacturer _____
Number of Cylinders (if applicable) _____
Type of Fuel (gas, gaseous, steam, etc) _____
Rating _____
Application _____

Control/Governor Information

Please list all Woodward governors, actuators, and electronic controls in your system:

Woodward Part Number and Revision Letter _____
Control Description or Governor Type _____
Serial Number _____

Woodward Part Number and Revision Letter _____
Control Description or Governor Type _____
Serial Number _____

Woodward Part Number and Revision Letter _____
Control Description or Governor Type _____
Serial Number _____

If you have an electronic or programmable control, please have the adjustment setting positions or the menu settings written down and with you at the time of the call.

Appendix A. Acronyms/Abbreviations

AUX	auxiliary
CRC	cyclic redundancy check
DFMEA	design failure modes and effects analysis
EEPROM	electrically-erasable programmable read-only memory
EMC	electro-magnetic compatibility
GUI	graphic user interface
I/O	inputs/outputs
IGN	ignition speed signal
Isoch	isochronous
ITB	integrated throttle body
L-Series	Woodward electronic engine governor that contains both a rotary actuator and a control circuit board
MPU	magnetic pick up
OEM	original equipment manufacturer
PWM	pulse-width modulated
rpm	revolutions per minute
RS-232	a communications standard
TPS	throttle position sensor

Appendix B.

L-Series Control Specifications

	Specifications
Power Supply	12/24 V systems (10–32 Vdc) reverse polarity protection, 2.5 A max
Power Consumption	32 W maximum
Torque	Nominal: 0.34 N·m (0.25 lb-ft) Minimum Transient (up to 105 °C): 0.28 N·m (0.21 lb-ft) Minimum Continuous (up to 105 °C): 0.20 N·m (0.15 lb-ft)
Mass/Weight	425 g (15 oz)
Power-Up to Operation Time	<250 ms
	Performance
Speed Control Accuracy	MPU Input: $\pm 0.25\%$ of rated speed on gasoline, diesel, or gaseous engines IGN Input: $\pm 0.5\%$ of rated speed on gasoline or gaseous engines
Transient Behavior	Gasoline: <10% at 100% load shed, <-10% at 100% load pick-up Gaseous: <10% at 100% load shed, <-10% at 100% load pick-up Diesel: <10% at 100% load shed, <-7% at 100% load pick-up

IMPORTANT

The specifications above are for naturally aspirated engines. Turbo-diesel applications can vary in the amount of load that can be picked-up within these specifications. Contact Woodward or consult ISO3046-4 and/or ISO8528-5 with questions about turbo specifications.

Recovery Time 3 seconds

Environment

Ambient Operating Temperature	-40 to +105 °C (-40 to +221 °F)
Storage Temperature	-40 to +125 °C (-40 to +257 °F)
EMC	EN61000-6-2: Immunity for Industrial Environments EN61000-6-4: Emissions for Industrial Environments SAE J1113-21: Radiated Immunity (100 V/m) SAE J1113-11: Conducted Transient Immunity – Pulse 5b, Suppressed Load Dump (45 V)
Humidity	US MIL-STD 810E, Method 507.3, Procedure III
Salt Spray	US MIL-STD 810E, Method 509.3, Procedure I
Shock	MS1-40G 11 ms sawtooth
Random Vibration	Random: 0.3 G ² /Hz, 10–2000 Hz (22.1 Grms) 3 h/axis Sine: 5 G 2.5 mm peak-to-peak, 5–2000 Hz, 3 h/axis, 90 min dwells, 1 octave/min
Drop	SAE J1211, Paragraph 4.8.3 (modified)
Thermal Shock	SAE J1455, Paragraph 4.1.3.2
Ingress Protection	IP56 per EN60529

Reliability and Quality Goals

The L-Series control system has a reliability target of 17 500 hours MTBF. It also has a quality goal of less than 25 PPM when measuring out-of-the-box defects. This quality goal is a target based on continuous improvement.

AUX 1 Analog Input

Parameter	Value
Input Type	0–5 V or $\pm 3V$ DC Input
Input Scaling	0 V = 0% and 5 V = 100% range in 0-5V mode. -3V = 0% and 3V = 100% range in $\pm 3V$ mode.
Max Input (Full Scale)	5 V \pm 1% or 3V \pm 1%
Min Input	0.1 V \pm 1% of Full Scale or $-2.88V \pm 1\%$ of Full Scale
Isolation	None
Transient Protection	According to EMC norm
Input Impedance	300 k Ω in 0–5 V synchronizing mode 10 k Ω in 0–5 V remote speed set mode 10 k Ω in ± 3 V synchronizing mode
Anti-Aliasing Filter	1 anti-aliasing pole at 0.5 ms (338 Hz)
Resolution	10 bits
Accuracy	$\pm 1.6\%$ of full scale over the temperature range of -40 to $+125$ °C, including drift
I/O Latency	6.5 ms
Calibration Method	2-point linear software calibration
Out of Range Signal	none
Overvoltage Protection	Input protected against 32 Vdc steady state

AUX 2–4 Analog Input

Parameter	Value
Input Type	0–5 V, Single-Ended Input
Input Scaling	0 V = 0% and 5 V = 100% range
Max Input (Full Scale)	5 V \pm 1%
Min Input	0 V \pm 1% of Full Scale
Isolation	None
Transient Protection	According to EMC norm
Input Impedance	499 k Ω
Anti-Aliasing Filter/AUX 2	1 anti-aliasing pole at 0.5 ms (338 Hz)
Anti-Aliasing Filter/AUX 3–4	1 anti-aliasing pole at 0.001 ms (159 kHz)
Resolution	10 bits
Accuracy	$\pm 1.3\%$ of full scale over the temperature range of -40 to $+125$ °C, including drift
I/O Latency	6.5 ms
Calibration Method	2-point linear software calibration
Out of Range Signal	none
Overvoltage Protection	Input protected against 32 Vdc steady state

Speed (MPU or Prox) Input

Parameter	Value
Input Magnitude	1–42 Vrms
Frequency Range	1 Hz – 12 kHz
Isolation	None
Input Impedance	113 k Ω
Accuracy	$\pm 0.25\%$ of point (controlled engine speed in rpm) over the temperature range of -40 to $+125$ °C, including drift for gasoline, diesel, and gaseous engines.
I/O Latency	6.5 ms
Out of Range Frequency	12 kHz is maximum sensed frequency. Out of range is determined by user-configured overspeed and start speed settings. See Chapter 6 for configuration.

IGN Input

Parameter	Value
Input Magnitude	-200 to $+250$ V Max. (-100 to $+150$ V Min.)
Frequency Range	1–480 Hz
Isolation	None
Input Impedance	44–113 k Ω
Accuracy	$\pm 0.5\%$ of point (controlled engine speed in rpm), over the temperature range of -40 to $+125$ °C, including drift, for both gasoline and gaseous applications.
I/O Latency	6.5 ms
Out of Range Frequency	480 Hz. Max (will not sense above this) Out of range is determined by user-configured overspeed and start speed settings. See Chapter 6 for configuration.

Discrete Input

Parameter	Value
Aux 1 Input Current	0.5 mA @ 5 Vdc
Aux 2,3,4 Input Current	10 μ A @ 5 V
Input Type	Ground referenced discrete input
Delay Time for Shutdown	< 200 ms for system to recognize shutdown if used for run/stop input.
Delay Time for Reset Detection	< 1 s for valves to move to minimum position if used for run/stop input.
Max Voltage from + Connection	32 V (power input voltage)
Isolation	None, Intended for use with external relay or other dry contact
Input Threshold (AUX 1)	> 3.1 Vdc = "ON"; < 0.8 Vdc = "OFF"
Input Thresholds (AUX 2-4)	> 2 Vdc = "ON"; < 0.8 Vdc = "OFF"
Input Impedance	Aux 1: 10 k Ω ; Aux 2,3,4: 499 k Ω

Discrete Output

Parameter	Value
Output Type	Low-side output driver
Max Contact Voltage (Open)	32 V
Max Current	0.5 A
Max Contact Voltage at 0.5 A (Closed)	1.5 V
Max Delay Time for Opening Contact	6.5 ms
Default at Power Up	Configurable in software
Error Condition	Configurable in software
OK Condition	Configurable in software
Driving Inductive Loads	Yes, internally protected low-side switch
Protection	Utilizes circuitry that will open the contact when output contacts are short-circuited. Self-resetting when fault is removed

TPS Output

Parameter	Value
Output Type	0–5 V, single-ended
Output Scaling	0.75 V = full ccw position and 4.25 V = full cw position
Isolation	None
3 db Circuit Bandwidth	350 Hz
Transient Protection	According to EMC norm
Output Impedance	2.8 k Ω (\pm 1%)
Accuracy	\pm 15% of full scale, @ 25 °C
Temperature Drift	\pm 0.4% over the full temperature range
I/O Latency	n/a—direct from position sensor
Calibration Method	Sensor-in-place factory calibration. 2-point linear
Out of Range Signal	< 0.25 V or > 4.75 V
Overvoltage Protection	Output protected against 32 Vdc, steady-state; if >28 V is applied to pin 2, a position-related error will be annunciated

RS-232 Serial Communication Service Port

Parameter	Value
Isolation	None
Baud Rate	Fixed 19.2 Kbaud
Electrical Interface	Outputs are TTL level. Requires external transceiver for conversion to RS-232 levels for proper communication !!
Pinout	Tx = pin 4, Rx = pin 6, Gnd = pin 3
Maximum Cable Length	10 m (33 ft), not meant for permanent connection (for service only)
Cable Type	Straight-through (no crossover)

Electronics Temperature Sensor

Parameter	Value
Accuracy	\pm 2 °C at 25 °C ambient \pm 3 °C over full range (–40 to +125 °C)
I/O Latency	6.5 ms

Software Execution Rates

Software Routine	Nominal Software Execution Rate
Position Control Algorithms	1.6 ms
Speed Input & Control Algorithms	6.5 ms
Analog Input Logic	6.5 ms
Serial Port	background task
Discrete Inputs	6.5 ms
Discrete Output	6.5 ms
Diagnostics	6.5 ms

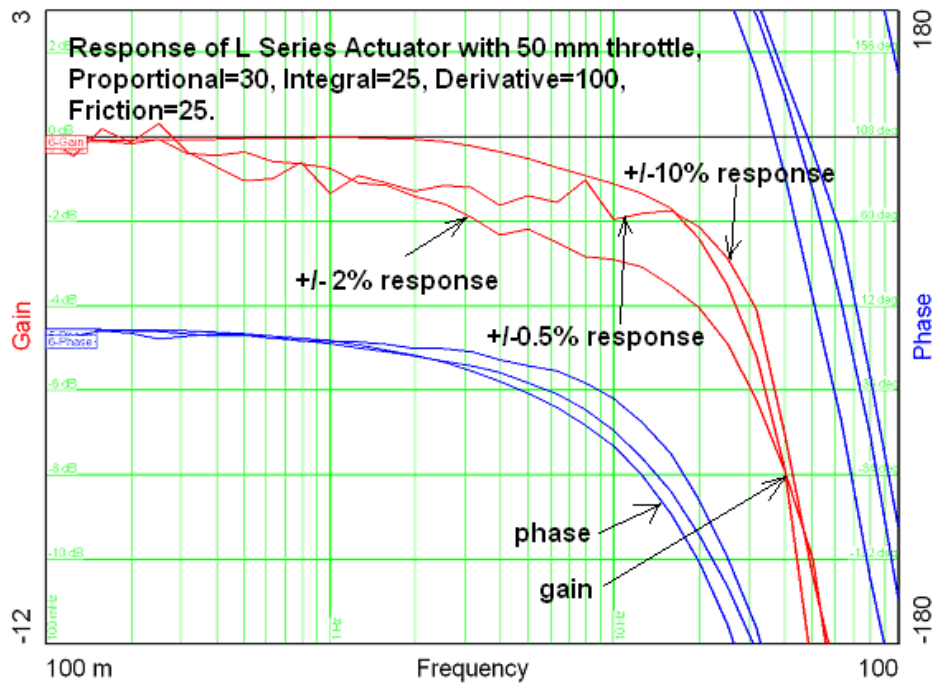

Figure B-1. Bode Plot of L-Series Response

DECLARATION OF CONFORMITY

According to EN 45014

Manufacturer's Name: WOODWARD GOVERNOR COMPANY (WGC)
Industrial Controls Group

Manufacturer's Address: 1000 E. Drake Rd.
Fort Collins, CO, USA, 80525

Model Name(s)/Number(s): L-Series
8404-xxxx and similar

Conformance to Directive(s): 89/336/EEC COUNCIL DIRECTIVE of 03 May 1989 on the approximation of the laws of the Member States relating to electromagnetic compatibility and all applicable amendments.

Units marked and conforming to ATEX conform to Directive: 94/9/EC COUNCIL DIRECTIVE of 23 March 1994 on the approximation of the laws of the Member States concerning equipment and protective systems intended for use in potentially explosive atmospheres

Markings on units conforming to ATEX: II 3 G, EEx nA II T3X, IP56

Applicable Standards: EN61000-6-4, (2001): EMC Part 6-4: Generic Standards - Emissions for Industrial Environments
EN61000-6-2, (2001): EMC Part 6-2: Generic Standards - Immunity for Industrial Environments
EN60079-15, (2003) Electrical apparatus for explosive gas atmospheres – Part 15: Type of protection 'n'

We, the undersigned, hereby declare that the equipment specified above conforms to the above Directive(s).

MANUFACTURER

Signature

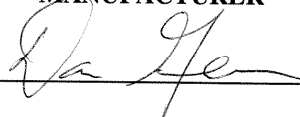

Dan Gear

Full Name

Engineering Manager

Position

WGC, Fort Collins, CO, USA

Place

Date

2/17/06

Declaration of Incorporation

Woodward Governor Company
1000 E. Drake Road
Fort Collins, Colorado 80525
United States of America

Product: L-Series Actuator
Part Number: 6300-1005 and similar

The undersigned hereby declares, on behalf of Woodward Governor Company of Loveland and Fort Collins, Colorado, that the above-referenced product is in conformity with the following EU Directives as they apply to a component:

98/37/EEC (Machinery)

This product is intended to be put into service only upon incorporation into an apparatus/system that itself will meet the requirements of the above Directives and bears the CE mark.

MANUFACTURER

Signature

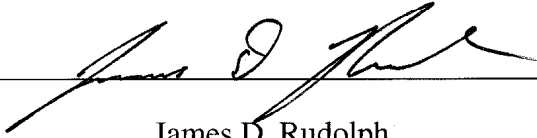

James D. Rudolph

Full Name

Engineering Manager

Position

WGC, Fort Collins, CO, USA

Place

11/13/07

Date

We appreciate your comments about the content of our publications.

Send comments to: icinfo@woodward.com

Please reference publication **26250J**.



PO Box 1519, Fort Collins CO 80522-1519, USA
1000 East Drake Road, Fort Collins CO 80525, USA
Phone +1 (970) 482-5811 • Fax +1 (970) 498-3058

Email and Website—www.woodward.com

**Woodward has company-owned plants, subsidiaries, and branches,
as well as authorized distributors and other authorized service and sales facilities throughout the world.**

Complete address / phone / fax / email information for all locations is available on our website.